

# SUNDOWN CONDOS AT POWDER MOUNTAIN PRUD

Site Permit Application Package  
 Approximately 6550 North Powder Mountain Road  
 Eden, Utah 84310

**OWNER**

OWNER Mike Brenny  
 PHONE: 801.808.9328  
 EMAIL: mike@thirdriverre.com

**CIVIL ENGINEER**

Fawkes Consultants  
 ADDRESS: 3474 N Wade Ln  
 Lehi, Utah 84043  
 CONTACT: Jordan "Guy" Williams, P.E.  
 PHONE: (213) 500-5936

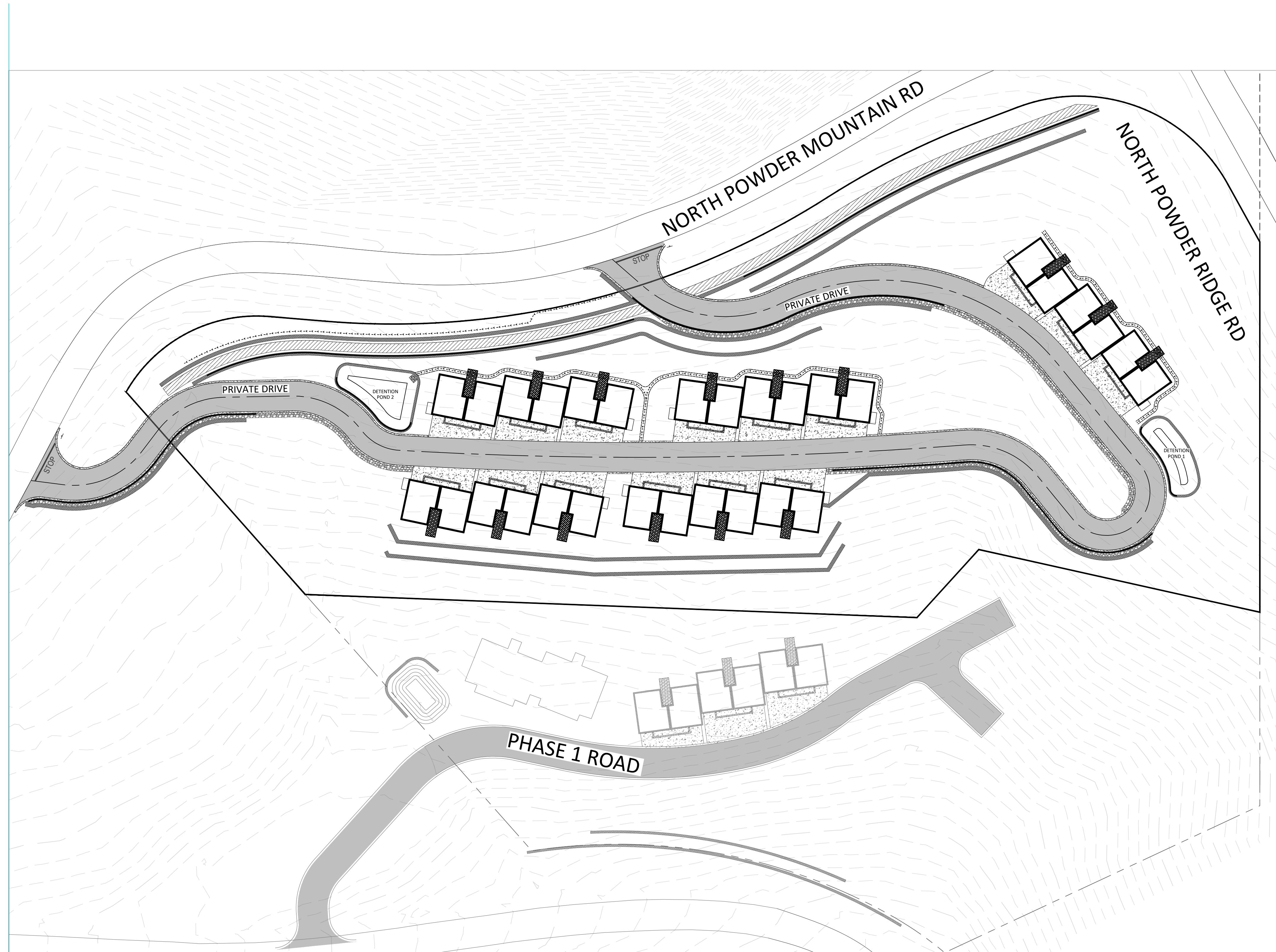

**SHEET INDEX**

SHEET NUMBER	SHEET TITLE
CV	COVER SHEET
SM	SITE MAP
GN	GENERAL NOTES
C100	DEMOLITION PLAN
C200	SITE PLAN
C300	GRADING PLAN
C400	UTILITY PLAN
C500	PLAN & PROFILE
C501	PLAN & PROFILE
C502	PLAN & PROFILE
C503	PLAN & PROFILE
C504	PLAN & PROFILE
C800	DETAILS
C801	DETAILS
C802	DETAILS

**SUBMITTAL SET**

REVISION	DATE
1	
2	
3	
4	
5	
6	

**COVER SHEET**  
**SUNDOWN CONDOS PHASE 2**  
 APPROX. 6550 NORTH POWDER MOUNTAIN ROAD  
 EDEN, UTAH 84310

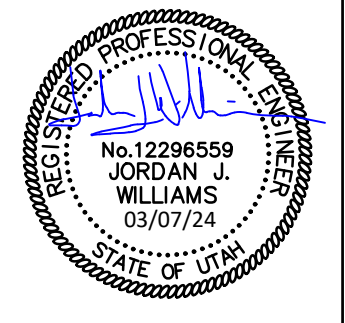

SCALE:

**CV**

DRAWN BY: DN

01/15



VICINITY MAP

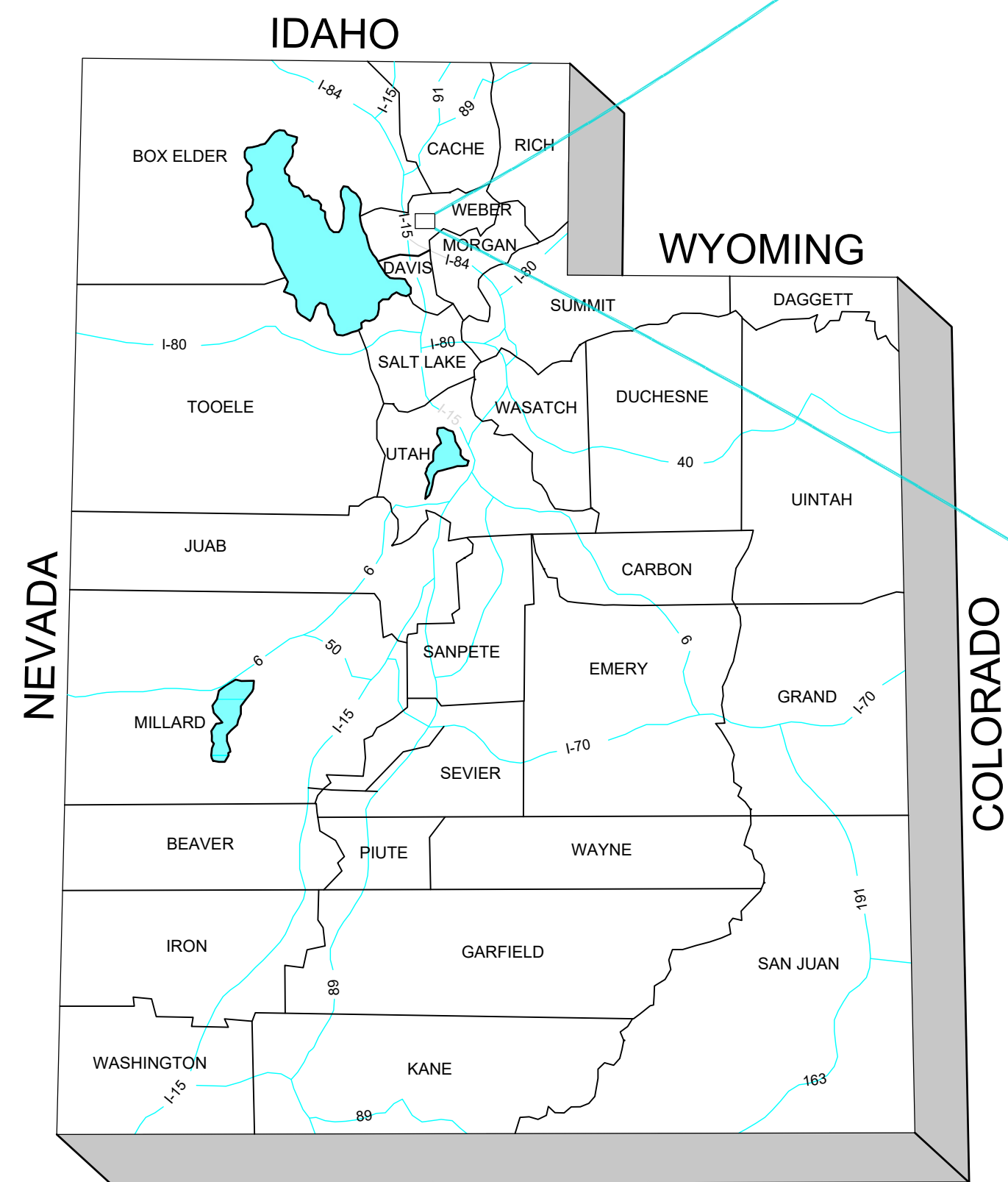
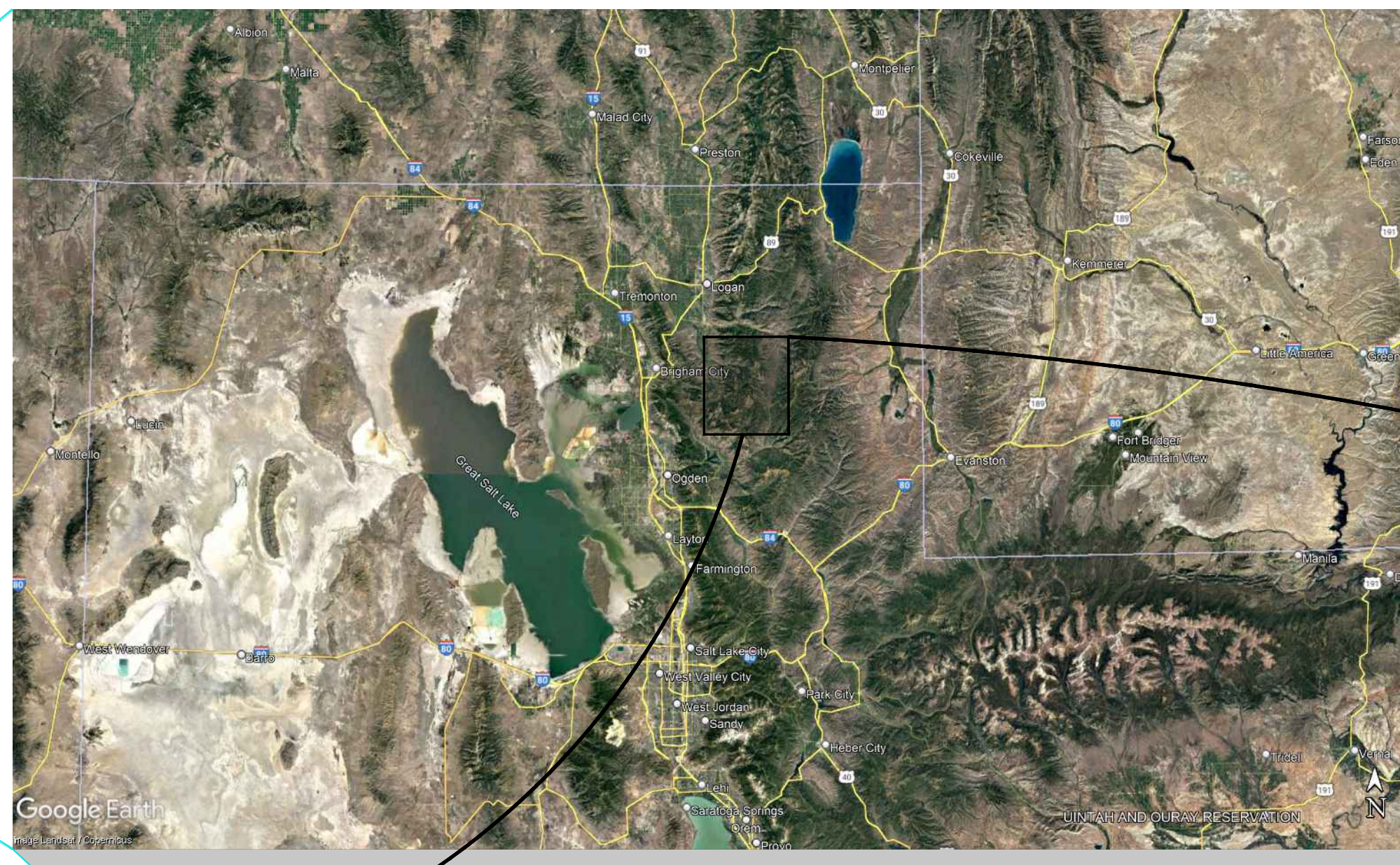

ARIZONA  
STATE MAP



PROJECT SITE

Google Earth

SITE MAP

**SUBMITTAL SET**

DATE:	03/07/2024
PROJECT NO.:	23.035
REVISION	DATE
1	
2	
3	
4	
5	
6	

**SITE MAP**  
**SUNDOWN CONDOS PHASE 2**  
APPROX. 6550 NORTH POWDER MOUNTAIN ROAD  
EDEN, UTAH 84310

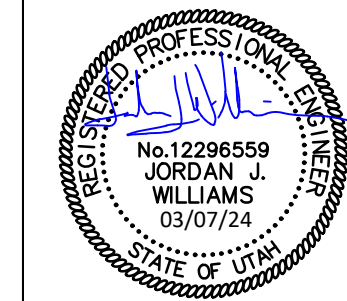

SCALE: 1"=40'

**SM**

DRAWN BY: DN

THE CONTRACTOR SHALL CAREFULLY READ ALL OF THE NOTES AND SPECIFICATIONS, THE CONTRACTOR SHALL BE SATISFIED AS TO THE TRUE MEANING AND INTENTION AND SHALL BE RESPONSIBLE FOR COMPLYING WITH EACH.

GENERAL NOTES:

1) ALL IMPROVEMENTS SHALL BE CONSTRUCTED IN STRICT ACCORDANCE WITH THE FOLLOWING: CURRENT REGULATORY AGENCY STANDARDS AND SPECIFICATIONS, AND REGULATORY AGENCY COMPREHENSIVE PLAN, WHERE APPLICABLE.

2) PRIOR TO ANY WORK BEING PERFORMED, THE CONTRACTOR SHALL CONTACT REGULATORY AGENCY FOR A PRE-CONSTRUCTION CONFERENCE AS DIRECTED BY THE OWNER. CONTRACTOR SHALL ALSO NOTIFY THE BELOW LISTED PROJECT CONTACTS (48) HOURS IN ADVANCE OF SAID MEETING:

- A. REGULATORY AGENCY: Weber County, 170 N Main St, Kamas, UT 84036 (435) 783-4630
B. DEVELOPER: DEV. Mike Brenny
C. ENGINEER: Fawkes Consultants, 3474 N Wade Ln, LEHI, UT 84043
D. GAS: DOMINION ENERGY, CUSTOMER SERVICE LINE: (800) 323-5517
E. POWER COMPANY: ROCKY MOUNTAIN POWER, CUSTOMER SERVICE LINE: (801) 465-8020
F. TELEPHONE COMPANY: CENTURYLINK, CUSTOMER SERVICE LINE: (800) 603-6000

3) IT IS INTENDED THAT THESE PLANS AND SPECIFICATIONS REQUIRE ALL LABOR AND MATERIALS NECESSARY AND PROPER FOR THE WORK CONTEMPLATED AND THAT THE WORK BE COMPLETED IN ACCORDANCE WITH THEIR TRUE INTENT AND PURPOSE.

4) WHERE THE PLANS OR SPECIFICATIONS DESCRIBE PORTIONS OF THE WORK IN GENERAL TERMS BUT NOT IN COMPLETE DETAIL, IT IS UNDERSTOOD THAT ONLY THE BEST GENERAL PRACTICE IS TO PREVAIL AND THAT ONLY MATERIALS AND WORKMANSHIP OF THE FIRST QUALITY ARE TO BE USED.

5) THE CONTRACTOR SHALL BE SKILLED AND REGULARLY ENGAGED IN THE GENERAL CLASS AND TYPE OF WORK CALLED FOR IN THE PROJECT PLANS AND SPECIFICATIONS. THEREFORE, THE OWNER IS RELYING UPON THE EXPERIENCE AND EXPERTISE OF THE CONTRACTOR, IT SHALL BE EXPECTED THAT PRICES PROVIDED WITHIN THE CONTRACT DOCUMENTS SHALL INCLUDE ALL LABOR AND MATERIALS NECESSARY AND PROPER FOR THE WORK CONTEMPLATED AND THAT THE WORK BE COMPLETED IN ACCORDANCE WITH THEIR TRUE INTENT AND PURPOSE.

6) THE CONTRACTOR SHALL BE RESPONSIBLE FOR ALL PERMITS AND LICENSES REQUIRED FOR THE CONSTRUCTION AND COMPLETION OF THE PROJECT, AND SHALL PERFORM ALL WORK IN ACCORDANCE WITH THE REQUIREMENTS AND CONDITIONS OF ALL PERMITS AND APPROVALS APPLICABLE TO THIS PROJECT.

7) CONTRACTOR SHALL OBTAIN A LAND DISTURBANCE PERMIT WHERE APPLICABLE FOR ANY WORK DONE WITHIN RIGHT-OF-WAYS OR EASEMENTS FROM REGULATORY AGENCY AND/OR UDOT. CONTRACTOR SHALL NOTIFY REGULATORY AGENCY, AND/OR STATE, 24 HOURS IN ADVANCE OF COMMENCING THE WORK, OR AS REQUIRED BY SAID PERMITS.

8) THE CONTRACTOR SHALL, AT THE TIME OF BIDDING, AND, THROUGHOUT THE PERIOD OF THE CONTRACT, BE LICENSED IN THE STATE OF UTAH AND SHALL BE BONDFOR FOR AN AMOUNT EQUAL TO OR GREATER THAN THE AMOUNT BID AND TO DO THE TYPE OF WORK CONTEMPLATED IN THE PLANS AND SPECIFICATIONS.

9) OWNER SHALL FILE NOTICE OF INTENT WITH THE STATE OF UTAH DIVISION OF WATER QUALITY AND ALSO OBTAIN A FUGITIVE DUST CONTROL PERMIT AS REQUIRED.

10) CONTRACTOR SHALL INSPECT THE SITE OF THE WORK PRIOR TO BIDDING TO SATISFY THEMSELVES BY PERSONAL EXAMINATION OR BY SUCH OTHER MEANS AS THEY MAY PREFER, OF THE LOCATION OF THE PROPOSED WORK, AND OF THE ACTUAL CONDITIONS OF AND AT THE SITE OF WORK.

IF, DURING THE COURSE OF THEIR EXAMINATION, A BIDDER FINDS FACTS OR CONDITIONS WHICH APPEAR TO THEM TO BE IN CONFLICT WITH THE LETTER OR SPIRIT OF THE PROJECT PLANS AND SPECIFICATIONS, THEY SHALL CONTACT THE ENGINEER FOR ADDITIONAL INFORMATION AND EXPLANATION BEFORE SUBMITTING THEIR BID.

SUBMISSION OF A BID BY THE CONTRACTOR SHALL CONSTITUTE ACKNOWLEDGMENT THAT, IF AWARDED THE CONTRACT, THEY HAVE RELIED AND ARE RELYING ON THEIR OWN EXAMINATION OF (1) THE SITE OF THE WORK, (2) ACCESS TO THE SITE, AND (3) ALL OTHER DATA AND MATTERS REQUISITE TO THE FULFILLMENT OF THE WORK AND ON THEIR OWN KNOWLEDGE OF EXISTING FACILITIES ON AND IN THE VICINITY OF THE SITE OF THE WORK TO BE CONSTRUCTED UNDER THIS CONTRACT.

THE INFORMATION PROVIDED BY THE OWNER OR THE ENGINEER IS NOT INTENDED TO BE A SUBSTITUTE FOR, OR A SUPPLEMENT TO THE INDEPENDENT VERIFICATION BY THE CONTRACTOR TO THE EXTENT SUCH INDEPENDENT INVESTIGATION OF SITE CONDITIONS IS DEEMED NECESSARY OR DESIRABLE BY THE CONTRACTOR.

11) THE CONTRACTOR SHALL PROVIDE ALL LIGHTS, BARRICADES, SIGNS, FLAGMEN OR OTHER DEVICES NECESSARY FOR PUBLIC SAFETY, AS REQUIRED BY REGULATORY AGENCY. IF TRAFFIC CONTROL IS NECESSARY, A TRAFFIC CONTROL PLAN SHOULD BE SUBMITTED TO REGULATORY AGENCY ENGINEERING DEPARTMENT FOR APPROVAL PRIOR TO ANY WORK BEING STARTED.

12) THE CONTRACTOR SHALL BE RESPONSIBLE TO PROVIDE ALL WATER, POWER, SANITARY FACILITIES AND TELEPHONE SERVICES AS REQUIRED FOR THE CONTRACTORS USE DURING CONSTRUCTION.

13) THE CONTRACTOR SHALL BE HELD RESPONSIBLE FOR ANY FIELD CHANGES MADE WITHOUT PRIOR WRITTEN AUTHORIZATION FROM THE OWNER, ENGINEER, AND/OR REGULATORY AGENCY.

14) THE CONTRACTOR SHALL EXERCISE DUE CAUTION AND SHALL CAREFULLY PRESERVE BENCH MARKS, CONTROL POINTS, REFERENCE POINTS AND ALL SURVEY STAKES, AND SHALL BEAR ALL EXPENSES FOR REPLACEMENT AND/OR ERRORS CAUSED BY THEIR UNNECESSARY LOSS OR DISTURBANCE.

15) THE CONTRACTOR AGREES THAT: A. THEY SHALL BE RESPONSIBLE TO CLEAN THE JOB SITE AT THE END OF EACH PHASE OF WORK.

B. THEY SHALL BE RESPONSIBLE TO REMOVE AND DISPOSE OF ALL TRASH, SCRAP AND UNUSED MATERIAL AT THEIR OWN EXPENSE IN A TIMELY MANNER.

C. THEY SHALL BE RESPONSIBLE TO MAINTAIN THE SITE IN A NEAT, SAFE AND ORDERLY MANNER AT ALL TIMES.

D. THEY SHALL BE RESPONSIBLE TO KEEP MATERIALS, EQUIPMENT, AND TRASH OUT OF THE WAY OF OTHER CONTRACTORS SO AS NOT TO DELAY THE JOB. FAILURE TO DO SO WILL RESULT IN A DEDUCTION FOR THE COST OF CLEAN UP FROM THE FINAL PAYMENT.

E. THEY SHALL BE RESPONSIBLE FOR THEIR OWN SAFETY, TRAFFIC CONTROL, PERMITS, RETESTING AND RE-INSPECTIONS AT THEIR OWN EXPENSE.

16) THE CONTRACTOR SHALL ASSUME SOLE AND COMPLETE RESPONSIBILITY FOR JOBSITE CONDITIONS DURING THE COURSE OF CONSTRUCTION OF THIS PROJECT, INCLUDING SAFETY OF ALL PERSONS AND PROPERTY. THIS REQUIREMENT SHALL APPLY CONTINUOUSLY AND NOT BE LIMITED TO NORMAL WORKING HOURS.

17) DUST CONTROL SHALL BE PROVIDED AT ALL TIMES, AT THE CONTRACTOR'S EXPENSE, TO MINIMIZE ANY DUST NUISANCE AND SHALL BE IN ACCORDANCE WITH REGULATORY AGENCY COMPREHENSIVE PLAN.

18) FOR ALL WORK WITHIN PUBLIC RIGHT-OF-WAYS OR EASEMENTS, THE CONTRACTOR SHALL PRESERVE THE INTEGRITY AND LOCATION OF ANY AND ALL PUBLIC UTILITIES AND PROVIDE THE NECESSARY CONSTRUCTION TRAFFIC CONTROL.

19) THE CONTRACTOR SHALL BE RESPONSIBLE FOR ADEQUATELY SCHEDULING INSPECTION AND TESTING OF ALL FACILITIES CONSTRUCTED UNDER THIS CONTRACT. ALL TESTING SHALL CONFORM TO THE REGULATORY AGENCY'S STANDARD SPECIFICATIONS.

20) IF EXISTING IMPROVEMENTS NEED TO BE DISTURBED AND/OR REMOVED FOR THE PROPER PLACEMENT OF IMPROVEMENTS TO BE CONSTRUCTED BY THESE PLANS, THE CONTRACTOR SHALL BE RESPONSIBLE FOR PROTECTING EXISTING IMPROVEMENTS FROM DAMAGE.

21) WHENEVER EXISTING FACILITIES ARE REMOVED, DAMAGED, BROKEN, OR CUT IN THE INSTALLATION OF THE WORK COVERED BY THESE PLANS OR SPECIFICATIONS, SAID FACILITIES SHALL BE REPLACED AT THE CONTRACTOR'S EXPENSE.

22) THE CONTRACTOR SHALL MAINTAIN A NEATLY MARKED SET OF FULL-SIZE AS-BUILT RECORD DRAWINGS SHOWING THE FINAL LOCATION AND LAYOUT OF ALL STRUCTURES AND OTHER FACILITIES.

PRIOR TO COMPLETION OF THE PROJECT, THE CONTRACTOR SHALL DELIVER TO THE ENGINEER, ONE SET OF NEATLY MARKED AS-BUILT RECORD DRAWINGS SHOWING THE INFORMATION REQUIRED ABOVE.

23) WORK IN EASEMENT AND/OR RIGHT-OF-WAY IS SUBJECT TO THE APPROVAL AND ACCEPTANCE OF THE REGULATORY AGENCY RESPONSIBLE FOR OPERATION AND/OR MAINTENANCE OF SAID EASEMENT AND/OR RIGHT-OF-WAY.

CLEARING AND GRADING NOTES:

1) CONTRACTOR SHALL PERFORM EARTHWORK IN ACCORDANCE WITH REGULATORY AGENCY STANDARD SPECIFICATIONS AND DIVISION 2 OF THE AMERICAN PUBLIC WORKS ASSOCIATION STANDARD SPECIFICATIONS.

2) IF THE PROJECT REQUIRES ANY IMPORT OR EXPORT TO ACHIEVE A BALANCED SITE, A SEPARATE UNIT PRICE PER CUBIC YARD SHALL BE INCLUDED IN THE BID FOR SAID IMPORT OR EXPORT.

UNDERGROUND UTILITIES:

1) THE INFORMATION SHOWN ON THE PLANS WITH REGARD TO THE EXISTING UTILITIES AND/OR IMPROVEMENTS, WAS DERIVED FROM FIELD INVESTIGATIONS AND/OR RECORD INFORMATION.

2) PRIOR TO COMMENCING ANY WORK, IT SHALL BE THE CONTRACTOR'S RESPONSIBILITY TO HAVE EACH UTILITY COMPANY LOCATE, IN THE FIELD, THEIR MAIN AND SERVICE LINES.

3) THE CONTRACTOR SHALL PROVIDE ALL SHORING, BRACING, SLOPING OR OTHER PROVISIONS NECESSARY TO PROTECT WORKMEN FOR ALL AREAS TO BE EXCAVATED TO A DEPTH OF 4' OR MORE.

4) PRIOR TO OPENING AN EXCAVATION, EFFORT SHALL BE MADE TO DETERMINE WHETHER UNDERGROUND INSTALLATIONS, I.E. SEWER, WATER, FUEL, ELECTRIC LINES, ETC., WILL BE ENCOUNTERED AND IF SO, WHERE SUCH UNDERGROUND INSTALLATIONS ARE LOCATED.

THE CONTRACTOR WILL VERIFY DEPTHS OF ALL UTILITIES IN THE FIELD BY POT HOLING A MINIMUM OF 300 FEET AHEAD OF PIPELINE CONSTRUCTION TO AVOID CONFLICTS WITH DESIGNED PIPELINE GRADE AND ALIGNMENT.

5) IT SHALL BE THE CONTRACTOR'S RESPONSIBILITY TO INSTALL PIPE OF ADEQUATE CLASSIFICATION WITH SUFFICIENT BEDDING TO MEET ALL REQUIREMENTS AND RECOMMENDATIONS OF THE REGULATORY AGENCY FOR H-20 LOAD REQUIREMENTS.

6) SANITARY SEWER AND WATER SYSTEM CONSTRUCTION TO BE INSTALLED PER THE REQUIREMENTS OF THE REGULATORY AGENCY. A. ALL SANITARY SEWER CONSTRUCTION SHALL COMPLY WITH THE REGULATORY AGENCY STANDARDS.

7) THE CONTRACTOR SHALL NOTIFY INFINITY CONSULTANTS, INC. IN WRITING AT LEAST 48 HOURS PRIOR TO BACKFILLING OF ANY PIPE WHICH STUBS TO A FUTURE PHASE OF CONSTRUCTION FOR INVERT VERIFICATION.

8) ALL UNDERGROUND UTILITIES SHALL BE IN PLACE PRIOR TO INSTALLATION OF CURB, GUTTER, SIDEWALK AND STREET PAVING.

9) THE CONTRACTOR IS RESPONSIBLE FOR ALL STREET LIGHT TRENCHING. SURFACE IMPROVEMENTS: 1) ALL MANHOLE RIMS, LAMPPOLES, VALVES AND MONUMENT BOXES, ETC. SHALL BE ADJUSTED TO FINISHED GRADE & COLLARED AFTER STREET PAVING.

2) PAYMENT FOR PAVEMENT WILL BE MADE ONLY FOR AREAS SHOWN ON PLANS. REPLACEMENT OF PAVEMENT WHICH IS BROKEN OR CUT DURING THE INSTALLATION OF THE WORK COVERED BY THESE SPECIFICATIONS,

3) THE CONTRACTOR SHALL BE RESPONSIBLE FOR THE REMOVAL OF ALL STRIPING AND/OR PAVEMENT MARKINGS NECESSARY TO THE EXISTING STRIPING INTO FUTURE STRIPING.

4) STRIPING AND PAVEMENT MARKINGS SHALL BE IN CONFORMANCE WITH REGULATORY AGENCY STANDARDS.

ROADWAY MATERIALS: ROADWAY MATERIALS SPECIFICATIONS AND CONSTRUCTION REQUIREMENTS SHALL BE AS OUTLINED BY REGULATORY AGENCY STANDARDS AND THESE PLANS.

SEWER IMPROVEMENT COMPLIANCE: 1) ALL CONSTRUCTION SHALL COMPLY WITH THE REGULATORY AGENCY'S DESIGN STANDARDS AND SPECIFICATIONS.

2) CONTRACTOR SHALL FIELD VERIFY LOCATIONS AND INVERT ELEVATIONS OF EXISTING MANHOLES AND OTHER UTILITIES BEFORE STAKING OR CONSTRUCTING ANY NEW SEWER LINES.

SWPPP NOTES: 1) SEE EROSION CONTROL SHEET FOR DETAILS AND BMP'S.

2) CONTRACTOR IS REQUIRED TO OBTAIN AN NOI FROM THE STATE OF UTAH FOR SWPPP PURPOSES.

3) CONTRACTOR IS REQUIRED TO SCHEDULE AND ATTEND A PRE-CONSTRUCTION MEETING WITH REGULATORY AGENCY PRIOR TO COMMENCING ANY SITE WORK FOR THIS PROJECT.

- GENERAL DEMOLITION NOTES: 1. Demolition and site clearing for this contract are to include all areas shown within demolition limits or by note. 2. Refer to site improvement plans for more details on limits of removal. 3. Demolish existing buildings and clear from site. 4. All curbs, gutters, walks, slabs, walls, fences, flatwork, asphalt, waterlines and meters, gas lines, sewer lines, light poles, buried cables, storm drain piping and structures to be cleared from site unless otherwise shown. 5. All utilities, sewer, water, gas, telephone and electrical services to be disconnected and capped according to city, county and utility company requirements, unless otherwise shown. 6. Basements and other excavated areas to be backfilled with clean granular material compacted to 95% of maximum lab density as determined by ASTM D 1557-78. 7. Clear and grub trees, shrubs, and vegetation within construction limits, disposal to be off-site except where noted otherwise. 8. DO NOT interrupt any services or disrupt the operation of any businesses shown outside the demolition limits. 9. If ASBESTOS is found in existing structures, the Asbestos must be removed in a legal manner by a contractor licensed to handle asbestos materials. 10. Remove debris, rubbish, and other materials resulting from the demolition and site clearing operations from the site and dispose of in a legal manner. 11. The location and/or elevation of existing utilities as shown on these plans is based on records of the various utility companies and, where possible, measurements taken in the field. 12. Contractor shall be responsible for disposal of all waste material. 13. Contractor shall verify utility with city any street removal, curb cuts, and any restoration required for utility line removal. 14. Contractor shall obtain all permits necessary for demolition from City, County, State or Federal Agencies as required.

- GENERAL SITE NOTES: 1. Stalls designated as accessible will require a painted accessible symbol and sign. 2. Fire lane markings and signs to be installed as directed by the Fire Marshall. 3. Aisle markings, directional arrows and stop bars will be painted at each driveway as shown on the plans. 4. Building sidewalks, ramps, and bollards are building contractor responsible items. 5. All dimensions are to back of curb unless otherwise noted. 6. Fire hydrants and access roads shall be installed prior to construction of any buildings. 7. All Street lighting installed within the project will be installed by the developer(s) and will be owned and maintained by the property owner(s).

- GENERAL GRADING NOTES: 1. Survey Provided by Owner. Civil Engineer not responsible for inaccuracies in survey information. 2. Contractor to verify in field data and to inform Civil Engineer of any discrepancies. 3. All work shall be in accordance with the City Public Works Standard. 4. Cut slopes shall be no steeper than 2 horizontal to 1 vertical. 5. Fill slopes shall be no steeper than 2 horizontal to 1 vertical. 6. Areas to receive fill shall be properly prepared and approved by the City inspector and geotechnical Engineer prior to placing fill. 7. Fills shall be benched into competent material as per specifications and geotechnical report. 8. A geotechnical engineer shall perform periodic inspections and submit a complete report and map upon completion of the rough grading. 9. The final compaction report and certification from the geotechnical engineer shall contain the type of field testing performed. 10. Dust shall be controlled by watering. 11. The location and protection of all utilities is the responsibility of the permittee. 12. Approved protective measures and temporary drainage provisions must be used to protect adjoining properties during the grading project. 13. Erosion Control: Protect all inlet boxes, catch basins, etc. with straw bales or other approved method to strain the storm water during construction. 14. All public roadways must be cleared daily of all dirt, mud and debris deposited on them as a result of the grading operation. 15. The site shall be cleared and grubbed of all vegetation and deleterious matter prior to grading. 16. The contractor shall provide shoring in accordance with OSHA requirements for trench walls. 17. Aggregate base shall be compacted per the geotechnical report prepared for the project. 18. Elevations shown on this plan are finish grades. 19. As part of the construction documents, owner has provided contractor with a topographic survey performed by manual or aerial means. 20. Erosion Control: Protect all inlet boxes, catch basins, etc. with straw bales or other approved method to strain the storm water during construction. 21. Refer to the site electrical plan for details and locations of electrical lines, transformers and light poles. 22. Gas lines, telephone lines, and cable TV lines are not a part of these plans unless otherwise noted. 23. Water meters are to be installed per city standards and specifications. 24. Water lines, valves, fire hydrants, fittings etc. are to be constructed as shown. 25. Field verify all existing and/or proposed Roof Drain/Roof Drain down spout connections to Storm Water System with Civil, Plumbing & Architectural plans. 26. All gravity flow utility lines shall be installed prior to any pressurized utilities unless written permission is obtained from the engineer of record before construction begins. 27. Fire hydrants and access roads shall be installed prior to construction of any buildings. 28. Prior to the construction of any buildings, a fire flow test of the new hydrants shall be conducted to verify the actual fire flow available for this project. 29. As a Private Development, the private fire hydrants shall be annually maintained and a 5-year flow test shall be performed in accordance with NFPA 24 and 25. 30. All records shall be provided and submitted through The Compliance Engine found at http://www.thecomplianceengine.com.

- UTILITY PIPING MATERIALS: All piping to be installed per manufacturers recommendations. Refer to project specifications for more detailed information regarding materials, installation, etc. CULINARY SERVICE LATERALS: 1. MAIN TO METER 2. Type 'K' copper or HDPE CTS-OD SDR-9 poly tubing. 3. 3/4" to 2" diameter pipe - CTS Poly, Soft Temper 4. Over 2" diameter pipe - AWWA C-900 Class 150 pipe

- WATER MAIN LINES AND FIRE LINES: 1. Pipe material as shown on utility plan view or to meet city standards. SANITARY SEWER LINES: 1. All sewer piping to be Polyvinyl Chloride (PVC) sewer pipe, ASTM D 3034, Type PSM, SDR 35

- STORM DRAIN LINES: 1. 12" pipes or smaller - Polyvinyl Chloride (PVC) sewer pipe, ASTM D3034, Type PSM, SDR 35 2. 12" or larger - Reinforced Concrete Pipe, ASTM C76, Class III up to 13' of cover, Class IV for 13' to 21' of cover, Class V for 21' to 32' of cover, and Special Design for cover greater than 32 feet.

- NATURAL GAS SERVICE LATERALS (QUESTAR) 1. PLASTIC PIPING MATERIAL: Plastic polyethylene pipe materials and compression couplings must be approved for natural gas applications and must be installed underground. 2. Plastic pipe must be joined by individuals qualified in the heat fusion method of connecting pipe and fittings or approved mechanical fittings. 3. Risers and prefabricated risers inserted with plastic pipe shall conform to ASTM D2513, shall be metallic, have a space of 10 inches from the bottom of the service valve and grade, and shall be wrapped or coated to a point at least 6 inches above grade or protected in an approved manner. 4. Plastic pipe used underground for customer fuel lines must be approved polyethylene material and be buried a minimum of 12 inches. 5. Stockpiles shall be graded to maintain slopes not greater than 3 horizontal to 1 vertical. 6. Plastic pipe used underground for customer fuel lines must be approved polyethylene material and be buried a minimum of 12 inches. 7. Stockpiles shall be graded to maintain slopes not greater than 3 horizontal to 1 vertical. 8. Plastic pipe used underground for customer fuel lines must be approved polyethylene material and be buried a minimum of 12 inches. 9. Stockpiles shall be graded to maintain slopes not greater than 3 horizontal to 1 vertical.

ABBREVIATIONS:

Table with 4 columns: AC, APPR, BW, CB, CL OR C, CONC, DET, DIA, DIP, DWG, EA, EG, EP, ELEV, ESMT, EXIST, FF, FH, FL, GB, HP, HORIZ, HYD, ID, I.E., IRR, L.F., LP. Corresponding to terms like ASPHALTIC CONCRETE, APPROXIMATELY, BOTTOM OF WALL, CATCH BASIN, CENTERLINE, CONCRETE, DETAIL, DIAMETER, DUCTILE IRON PIPE, DRAWING, EACH, EXISTING GRADE, EDGE OF PAVEMENT, ELEVATION, EASEMENT, EXISTING, FINISH FLOOR, FIRE HYDRANT, FLOWLINE, FEET, GRADE BREAK, HIGH POINT, HORIZONTAL, HYDRANT, INSIDE DIAMETER, INVERT ELEVATION, IRRIGATION LENGTH, LINEAR FEET, LOW POINT.

GRAPHIC SCALE:

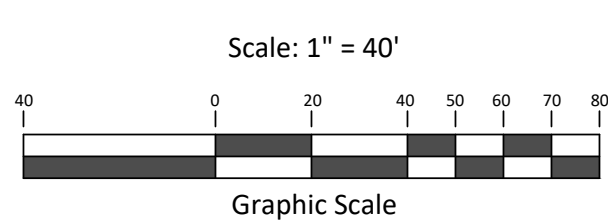

NORTH ARROW:

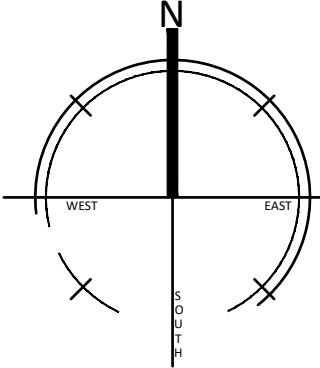

Legend

(Note: All items may not appear on drawing)

- San. Sewer Manhole, Water Manhole, Storm Drain Manhole Cleanout, Electrical Manhole, Catch Basins, Exist. Fire Hydrant, Fire Hydrant, Exist. Water Valve, Water Valve, Power pole, Power pole w/guy, Light Pole, Fence, Metal Pipe, Concrete Pipe, Reinforced Concrete Pipe, Ductile Iron Pipe, Top of Asphalt, Edge of Asphalt, Centerline, Existing Grade, Flowline, Finish Floor, Finish Grade, Top of Curb, Top of Wall, Top of Walk, Top of Concrete, Natural Ground, Match Existing, Fire Department Connection, Ridge Line, Direction of Flow.

- Existing Asphalt, New Asphalt, Heavy Duty Asphalt, Existing Concrete, New Concrete, Split Curb & Gutter.



3474 N Wade Ln, Lehi, UT 84043, Gwilliams@fawkesconsultants.com

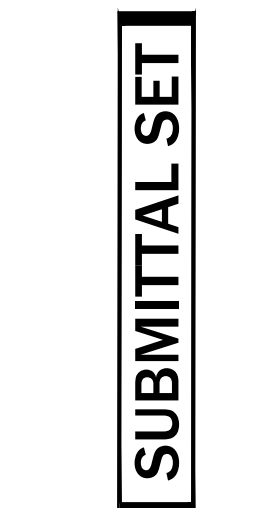
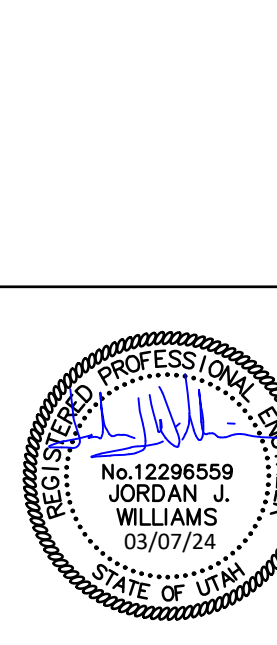

Table with columns: REVISION, DATE. Rows 1-6.

DATE: 03/07/2024, PROJECT NO.: 23.035

Table with columns: REVISION, DATE. Rows 1-6.

GENERAL NOTES, SUNDOWN CONDOS PHASE 2, APPROX. 6550 NORTH POWDER MOUNTAIN ROAD, EDEN, UTAH 84310



SCALE:

GN

DRAWN BY: DN

03/15



1-800-662-4111

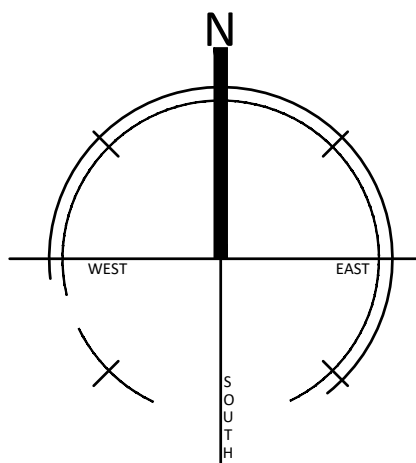
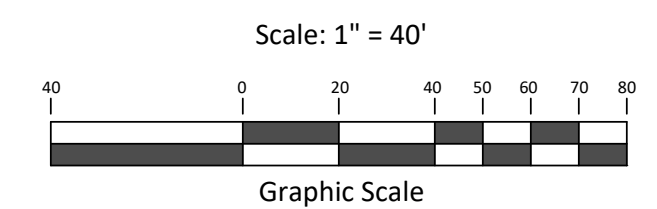

**SUBMITTAL SET**

DATE: 03/07/2024  
PROJECT NO. 23.035

REVISION	DATE
1	
2	
3	
4	
5	
6	

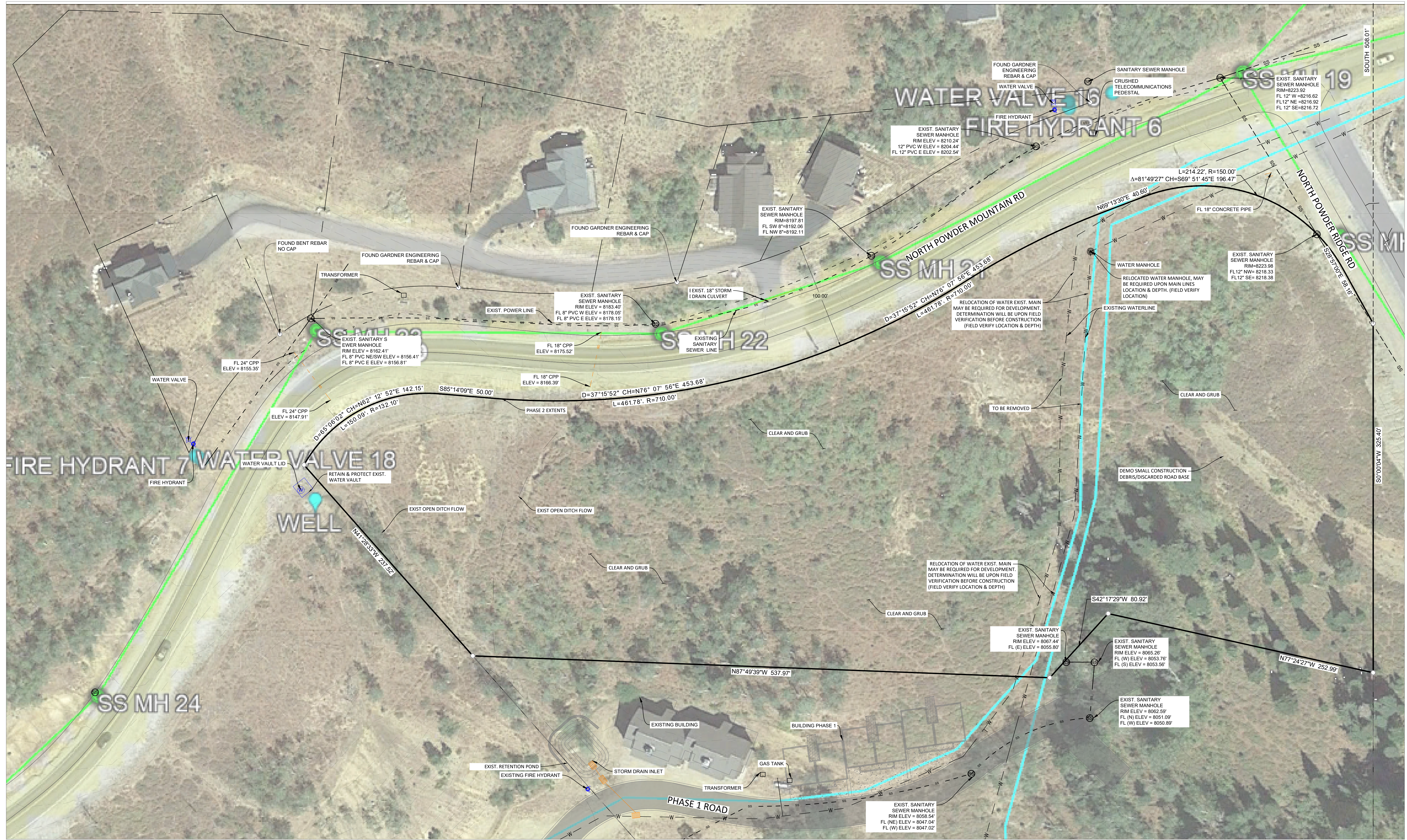

**DEMOLITION PLAN**  
**SUNDOWN CONDOS PHASE 2**  
APPROX. 6550 NORTH POWDER MOUNTAIN ROAD  
EDEN, UTAH 84310

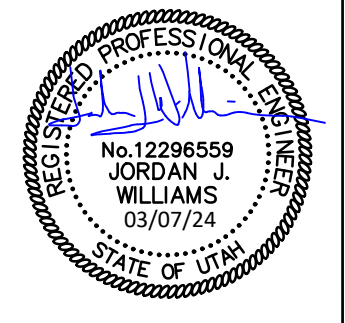

SCALE: 1"=40'

**C100**

DRAWN BY: DN

04/15

DATE:	03/07/2024
PROJECT NO.:	23.035
REVISION	DATE
1	
2	
3	
4	
5	
6	

**SITE PLAN**  
**SUNDOWN CONDOS PHASE 2**  
APPROX. 6550 NORTH POWDER MOUNTAIN ROAD  
EDEN, UTAH 84310

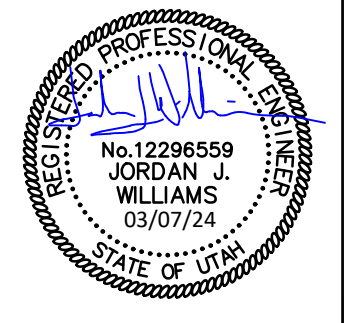

SCALE: 1"=40'

**C200**

DRAWN BY: DN

05/15

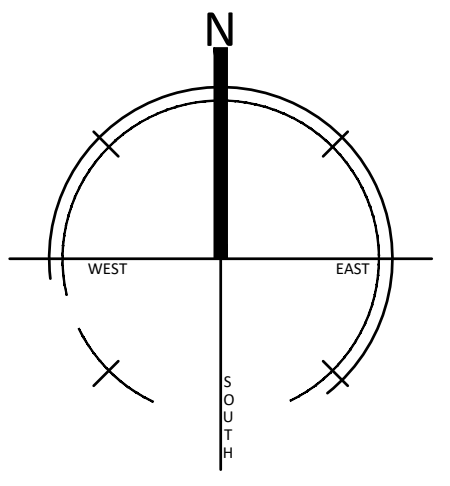
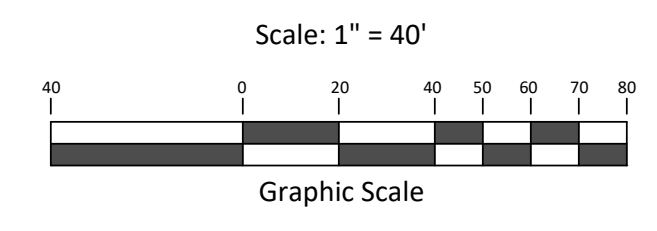
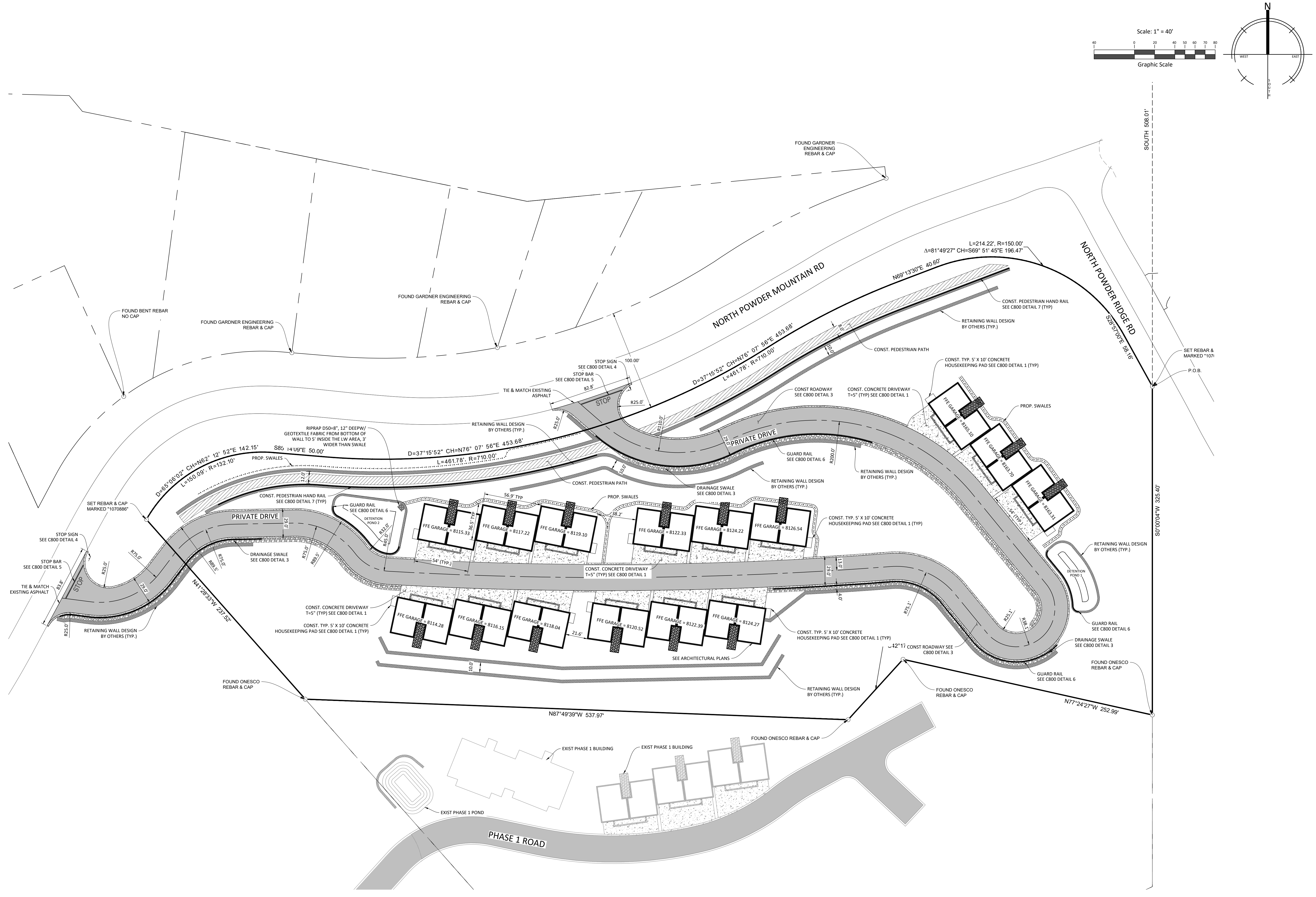

**SUBMITTAL SET**

DATE: 03/07/2024  
PROJECT NO: 23.035

REVISION	DATE
1	
2	
3	
4	
5	
6	

**GRADING PLAN**  
**SUNDOWN CONDOS PHASE 2**  
APPROX. 6550 NORTH POWDER MOUNTAIN ROAD  
EDEN, UTAH 84310

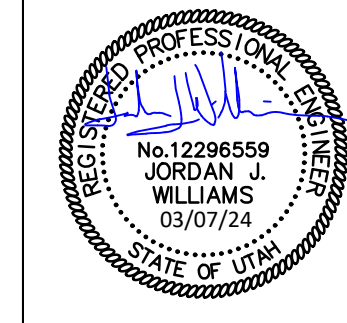

SCALE: 1"=30'

**C300**

DRAWN BY: DN

06/15

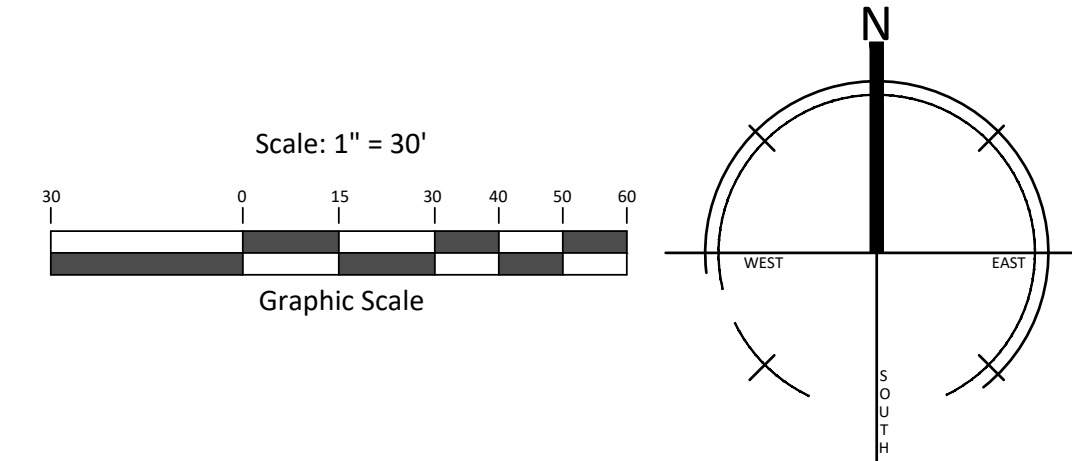
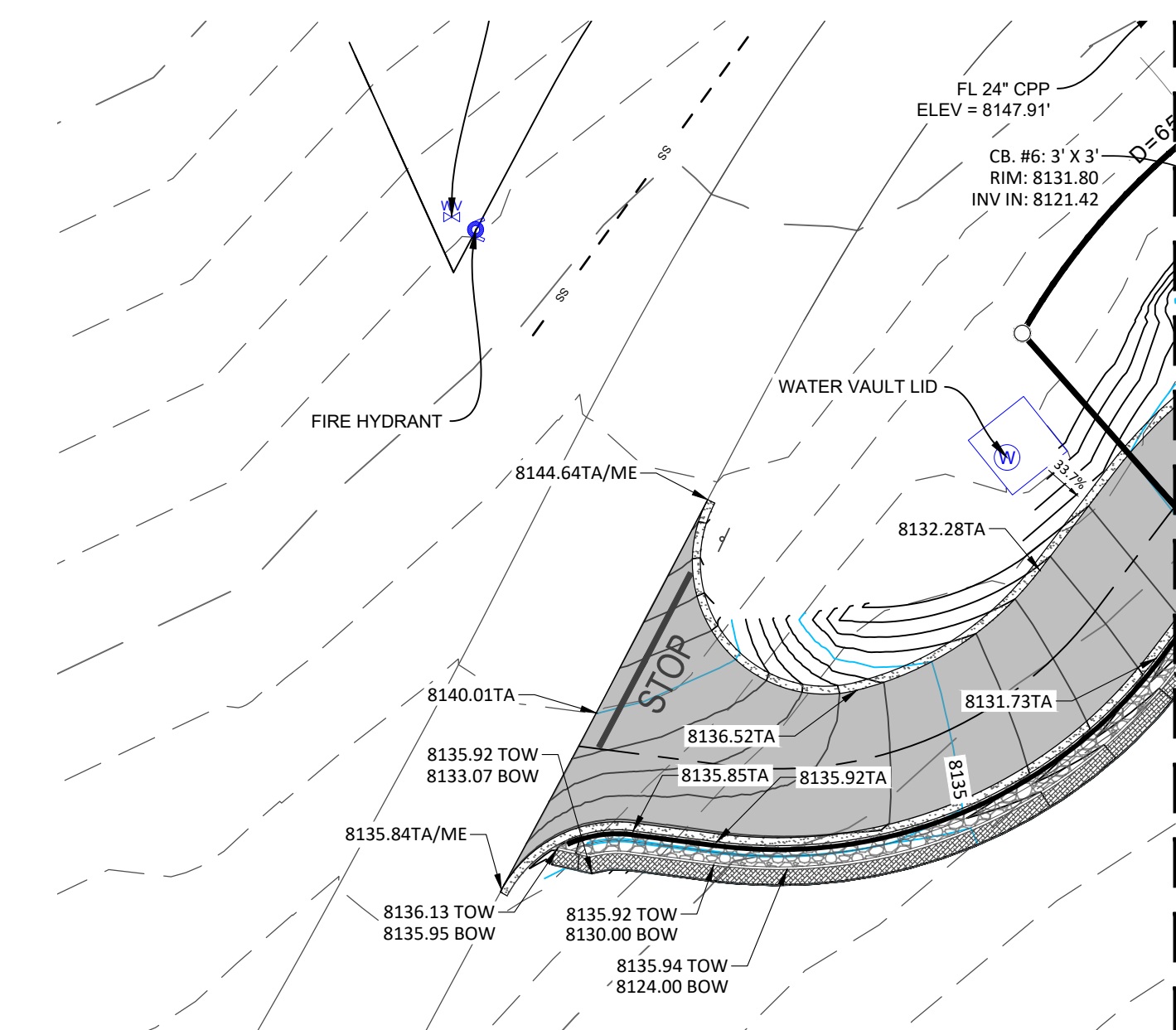

DATE: 03/07/2024  
PROJECT NO. 23.035

REVISION	DATE
1	
2	
3	
4	
5	
6	

**UTILITY PLAN**  
**SUNDOWN CONDOS PHASE 2**  
APPROX. 6550 NORTH POWDER MOUNTAIN ROAD  
EDEN, UTAH 84310

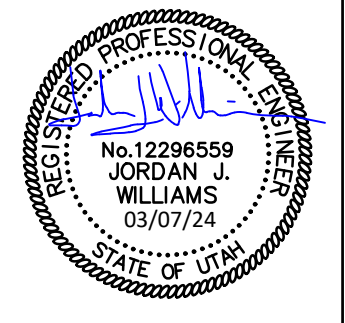

SCALE: 1"=40'

**C400**

DRAWN BY: DN

07/15

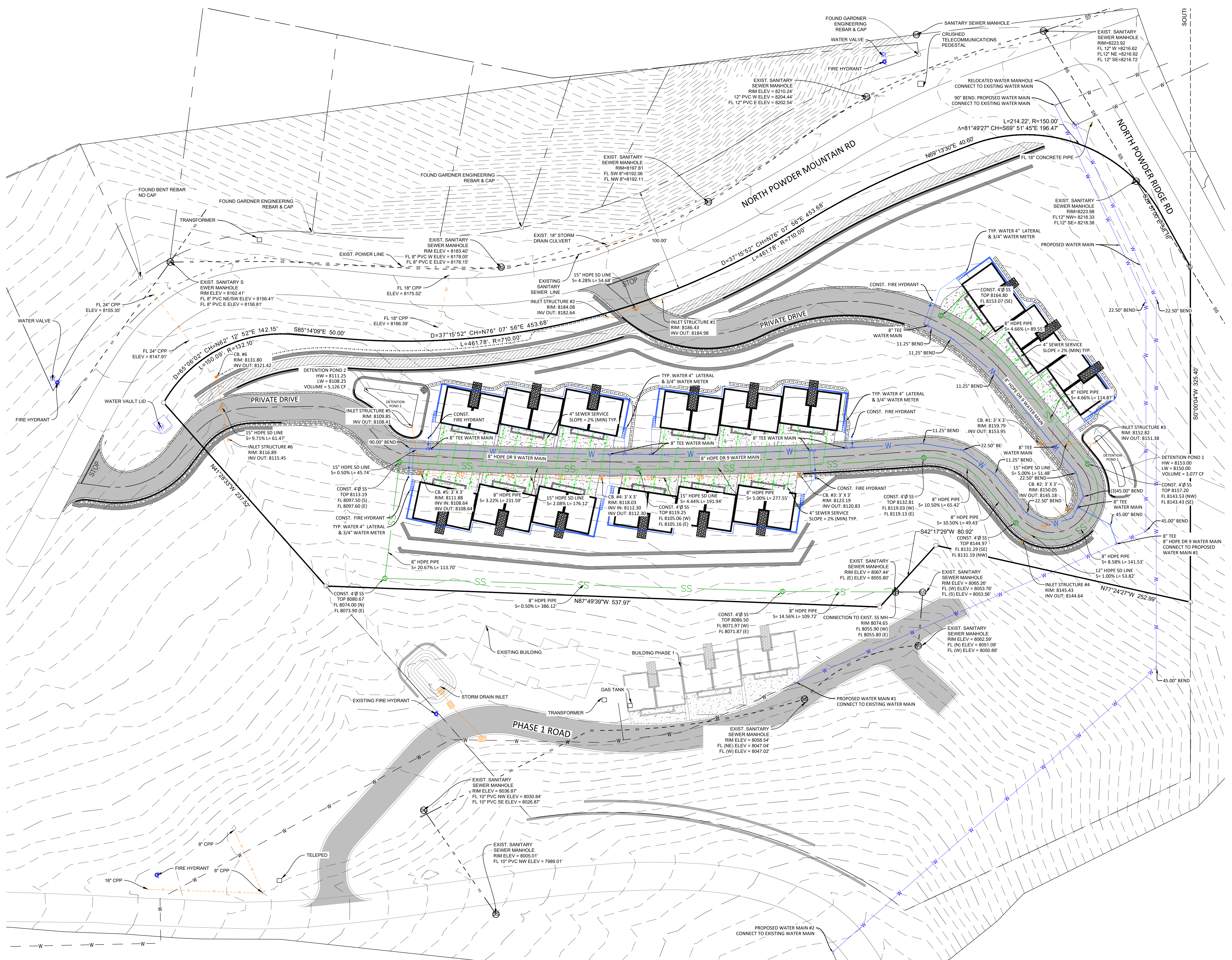
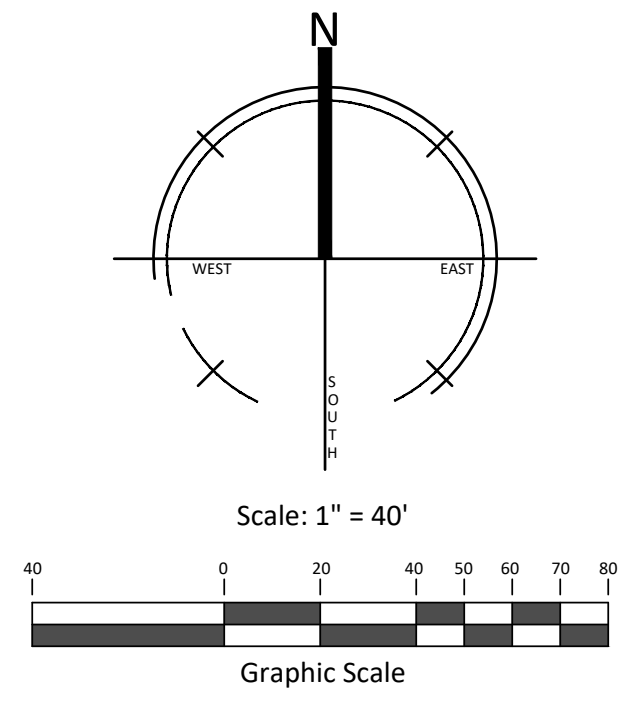







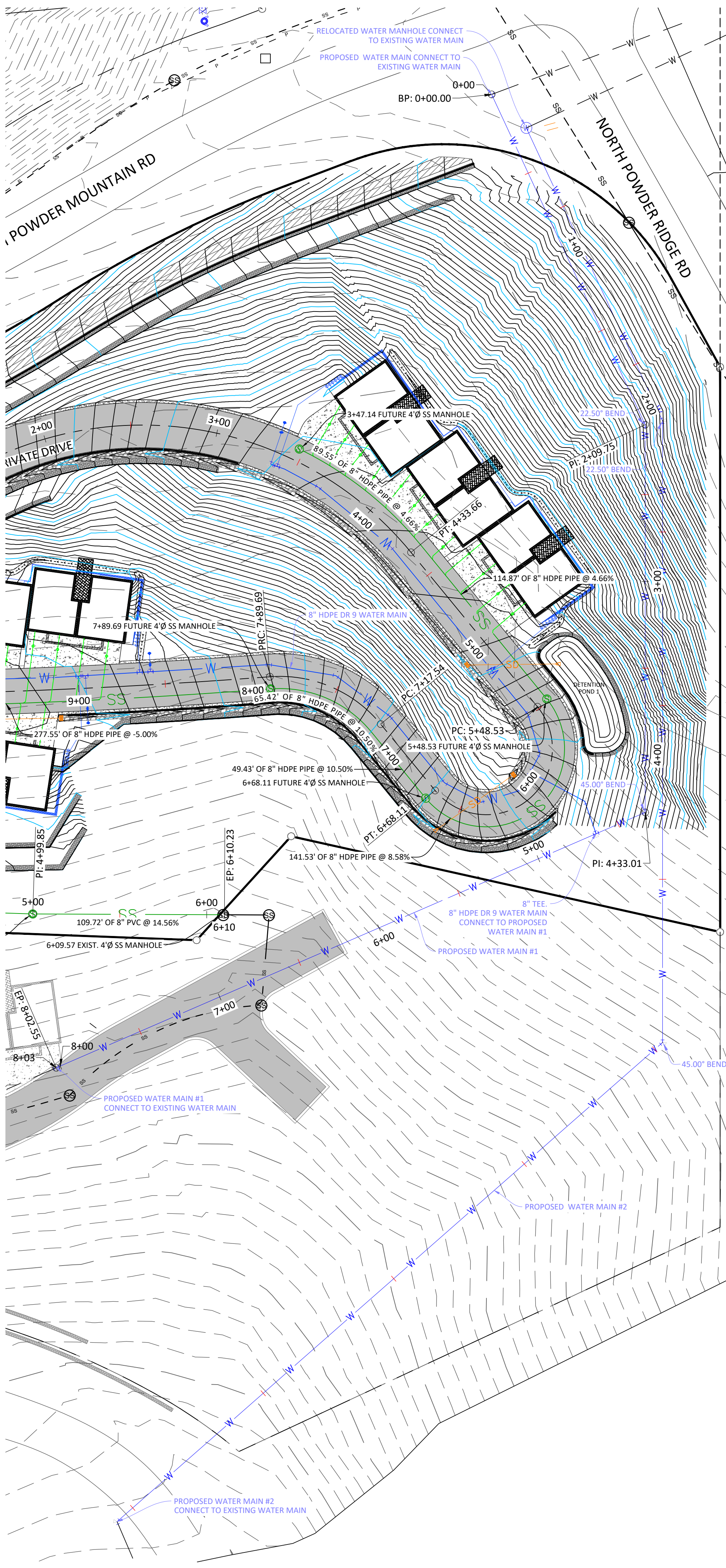

**PROPOSED WATER MAIN #1 PLAN**

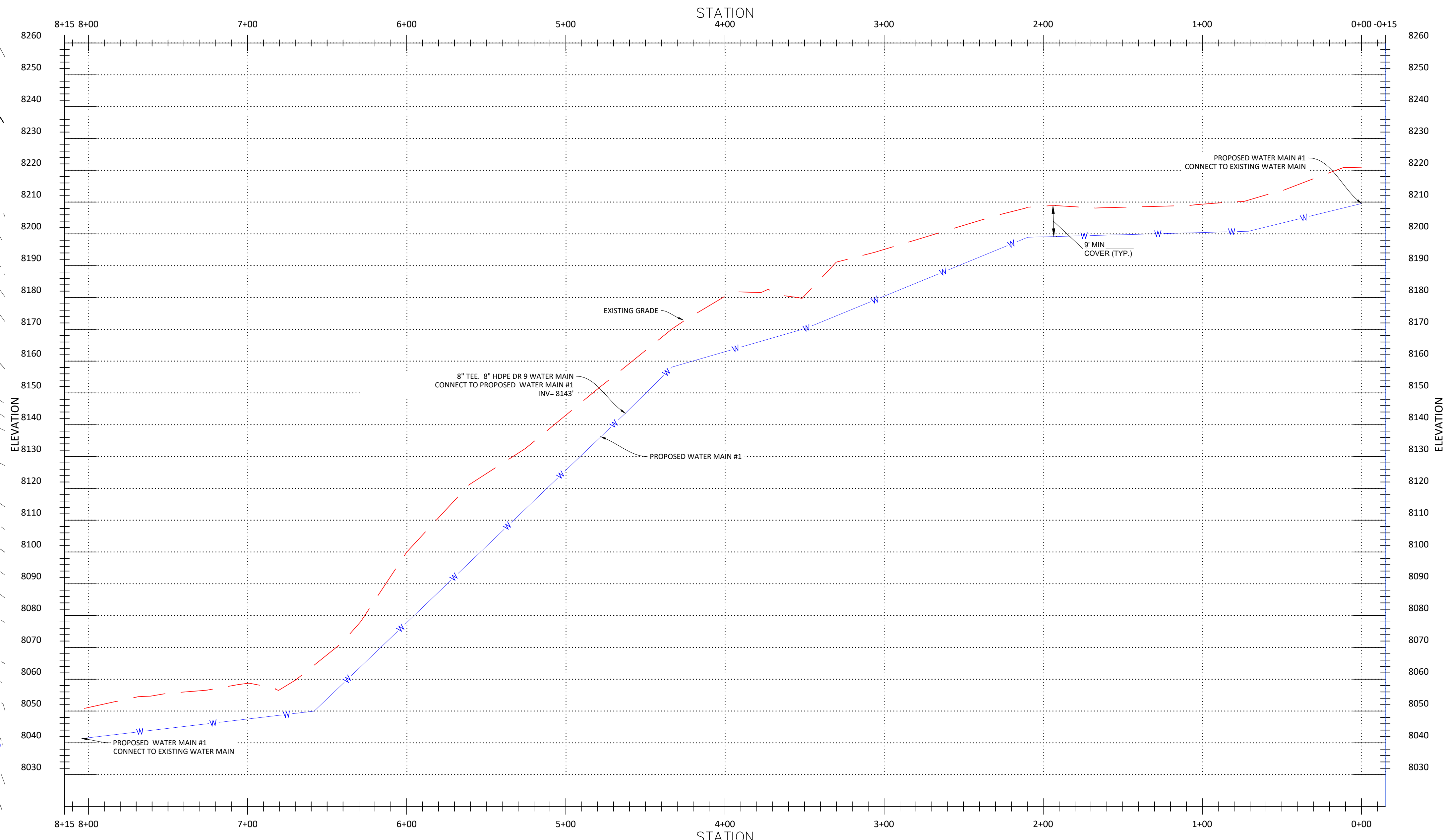

**PROPOSED WATER MAIN #1 PROFILE**

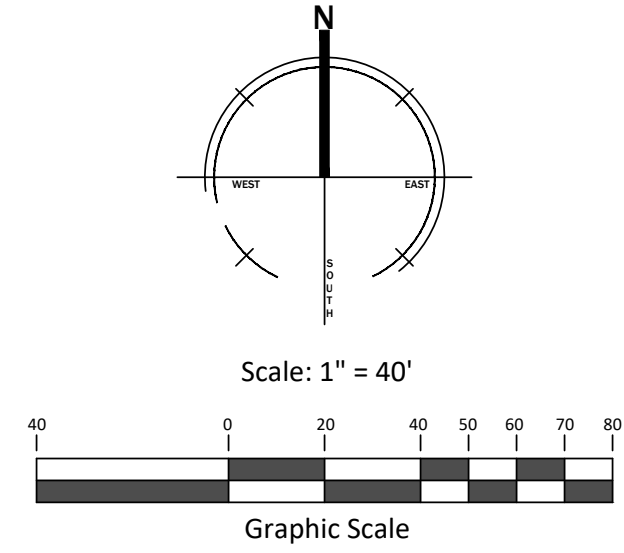

**SUBMITTAL SET**

DATE:	03/07/2024
PROJECT NO.:	23.035
REVISION	DATE
1	
2	
3	
4	
5	
6	

**PLAN & PROFILE**  
**SUNDOWN CONDOS PHASE 2**  
APPROX. 6550 NORTH POWDER MOUNTAIN ROAD  
EDEN, UTAH 84310

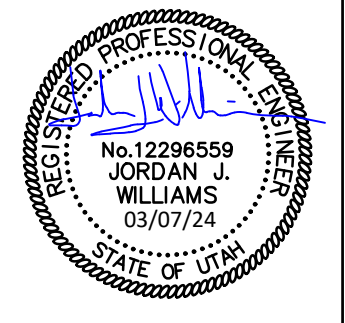

SCALE: 1"=40'

**C502**

DRAWN BY: DN

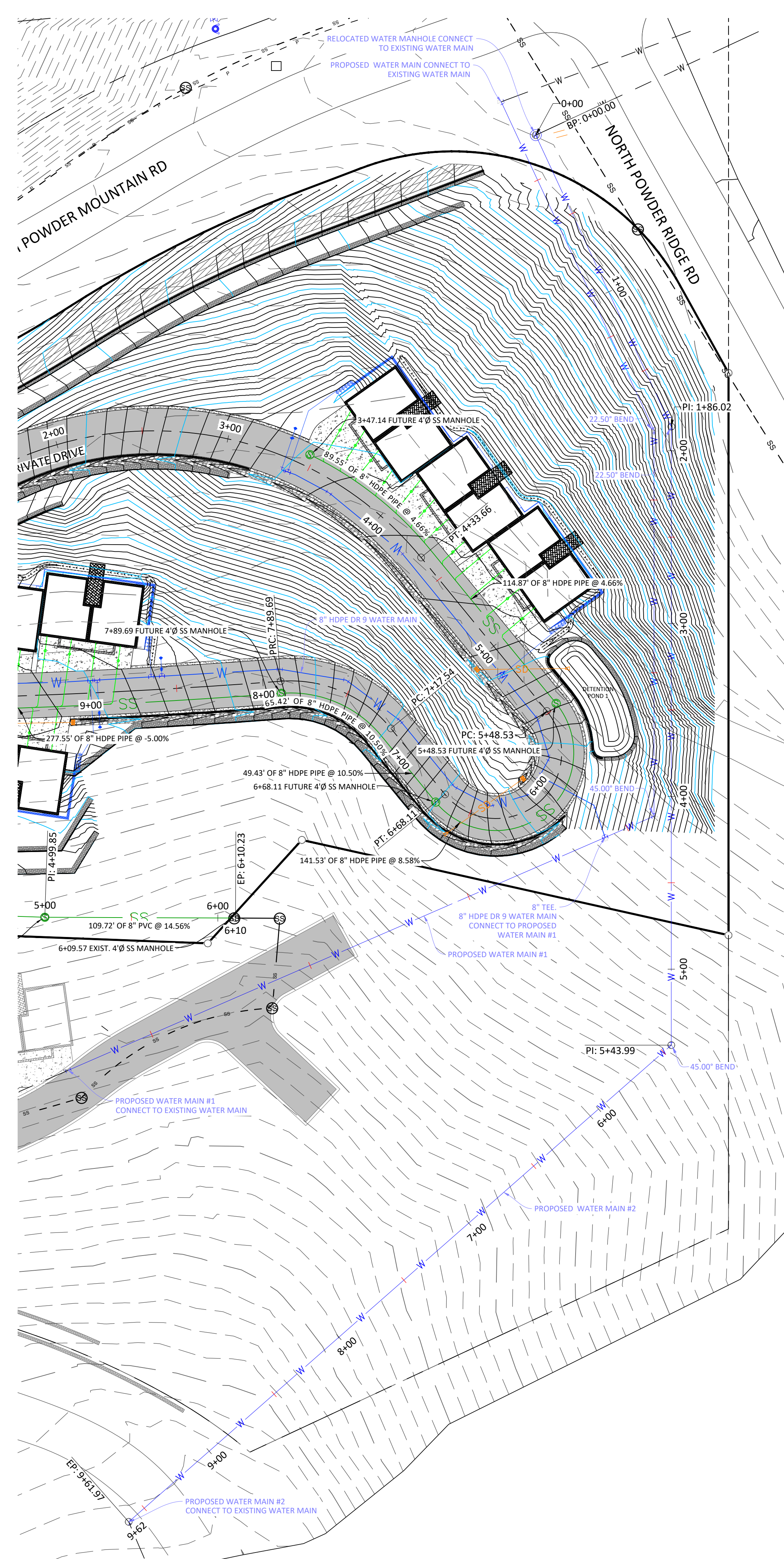

**PROPOSED WATER MAIN #2 PLAN**

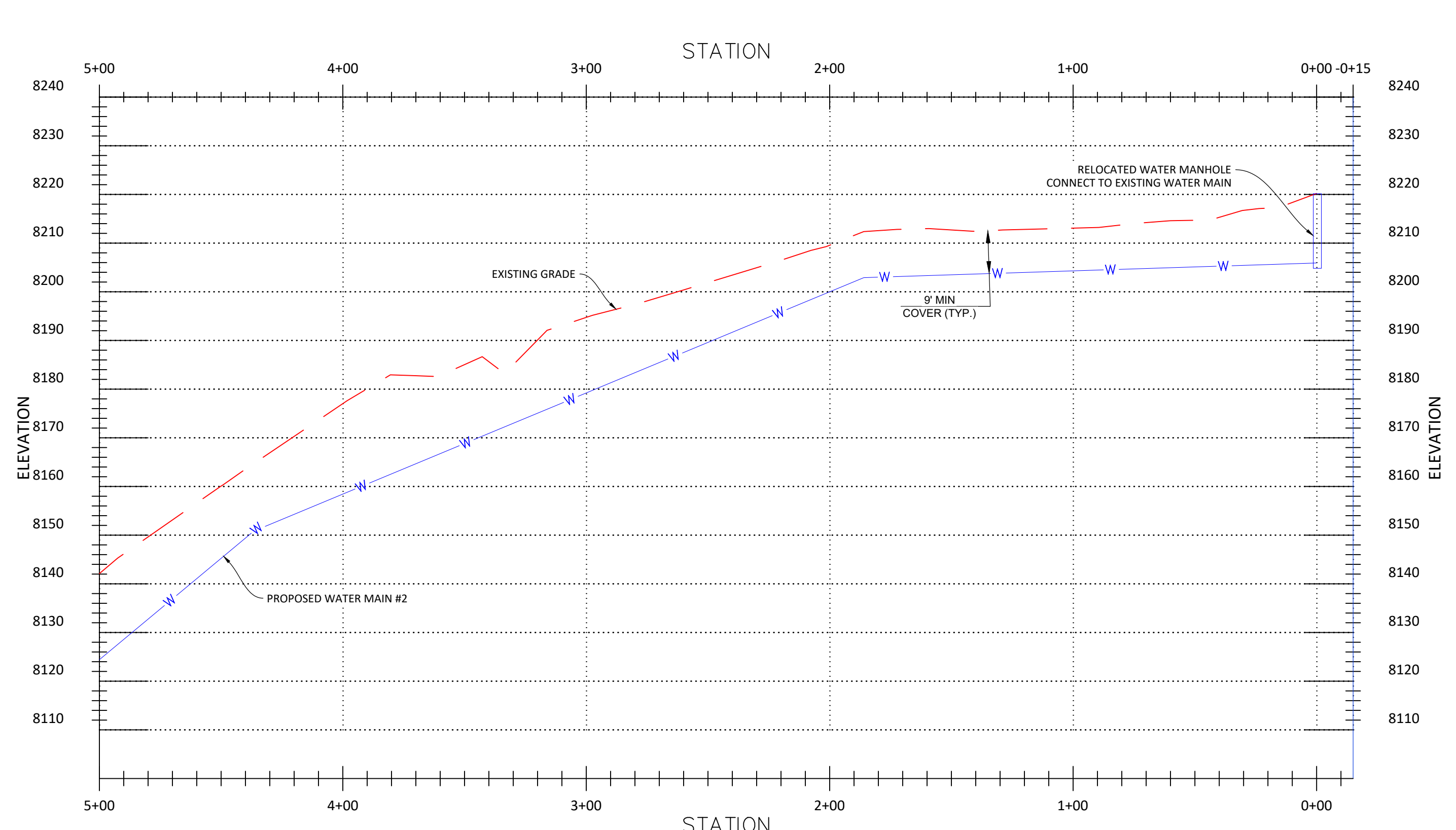

**PROPOSED WATER MAIN #2 PROFILE**

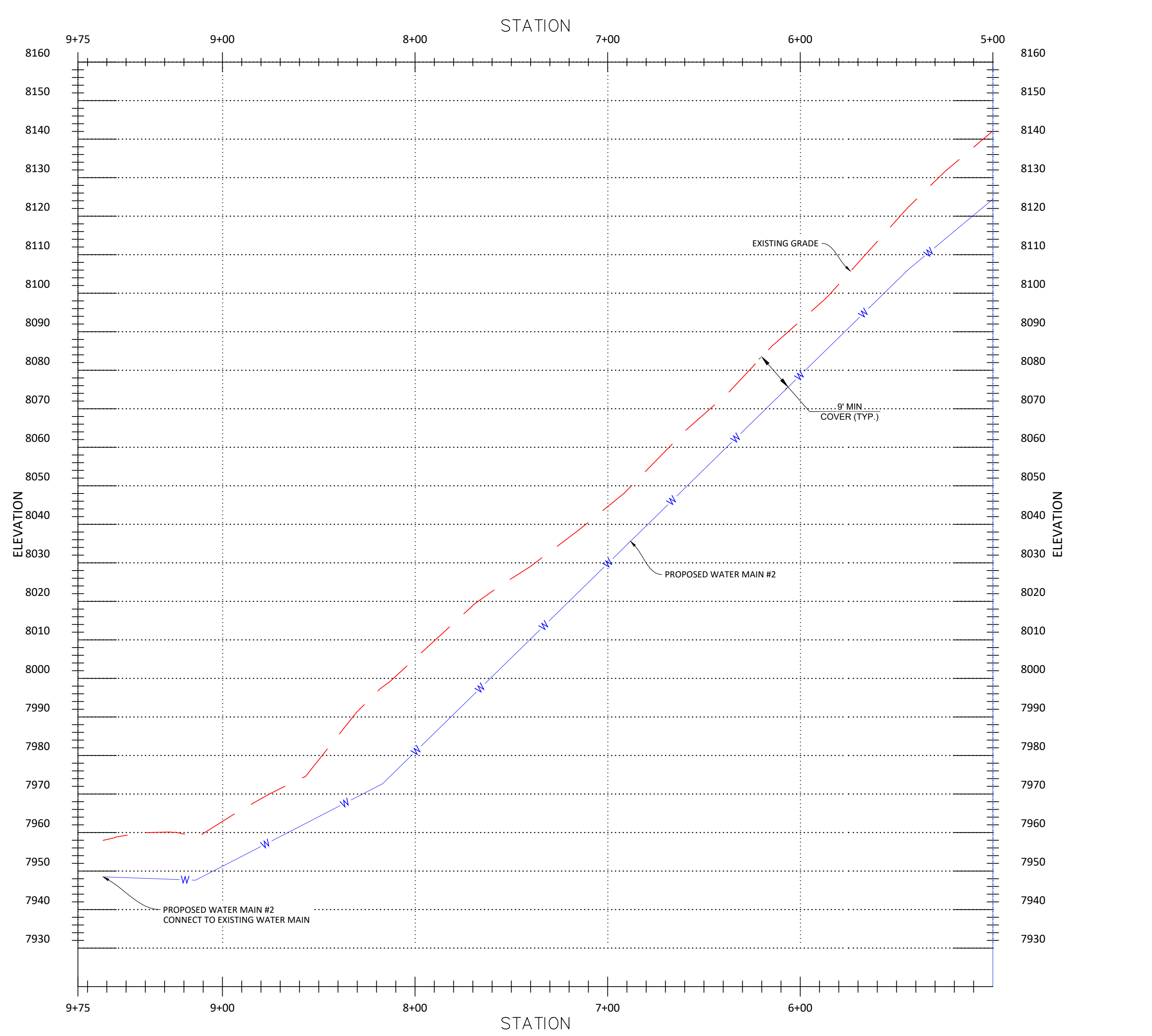

**PROPOSED WATER MAIN #2 PROFILE**

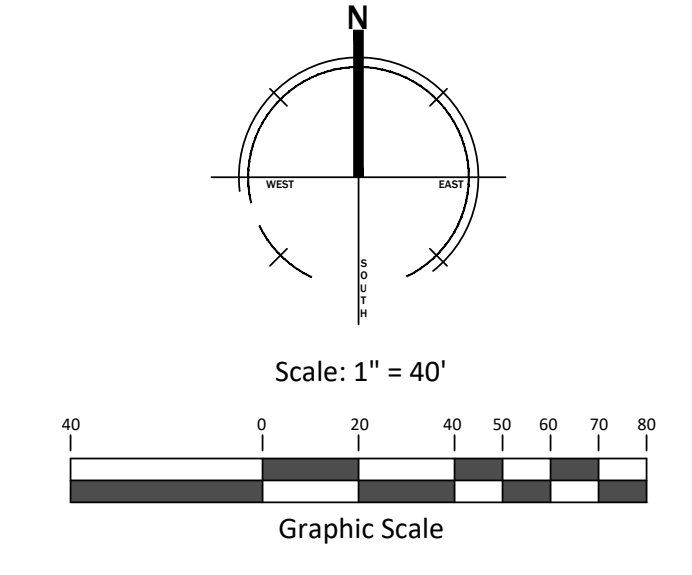

REVISION	DATE
1	
2	
3	
4	
5	
6	

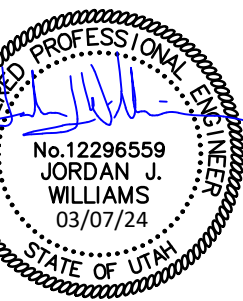

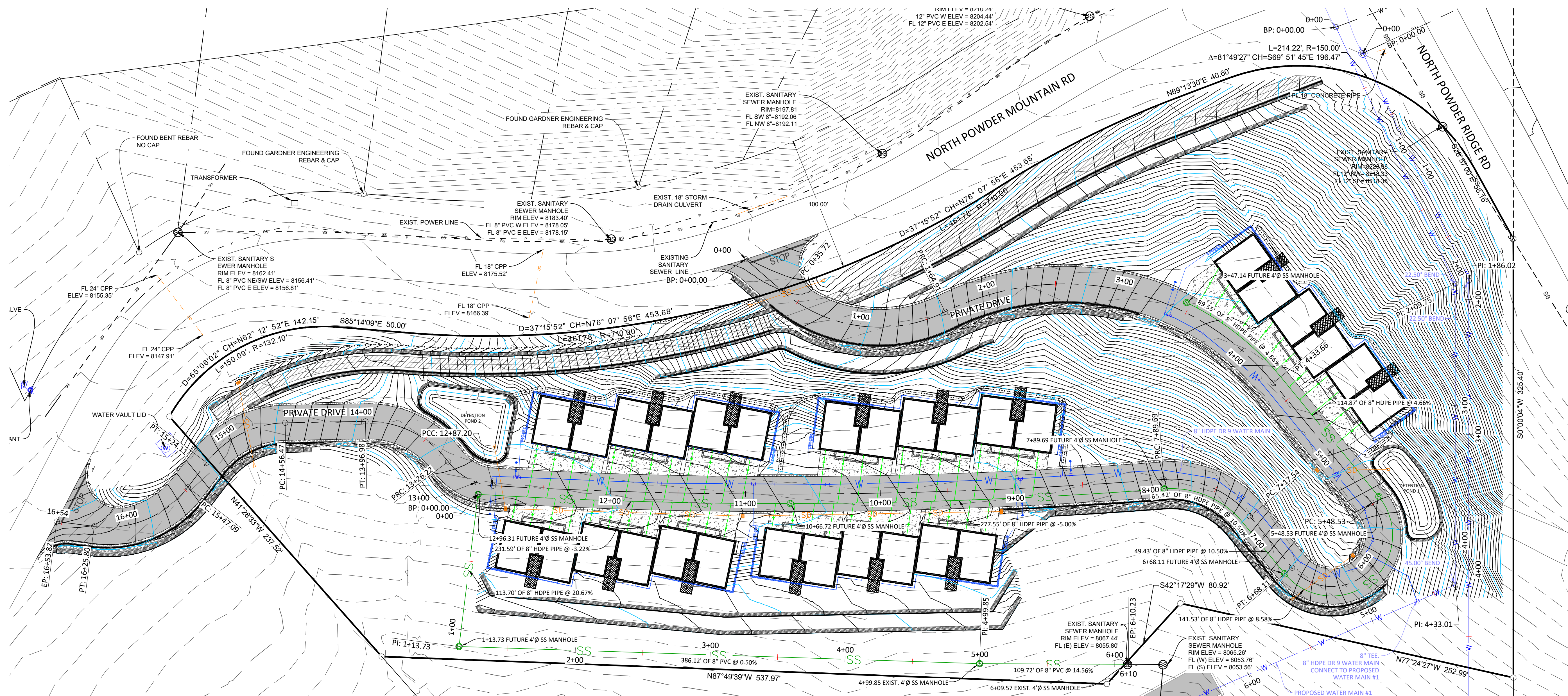

**PEDESTRIAN PATH PLAN**

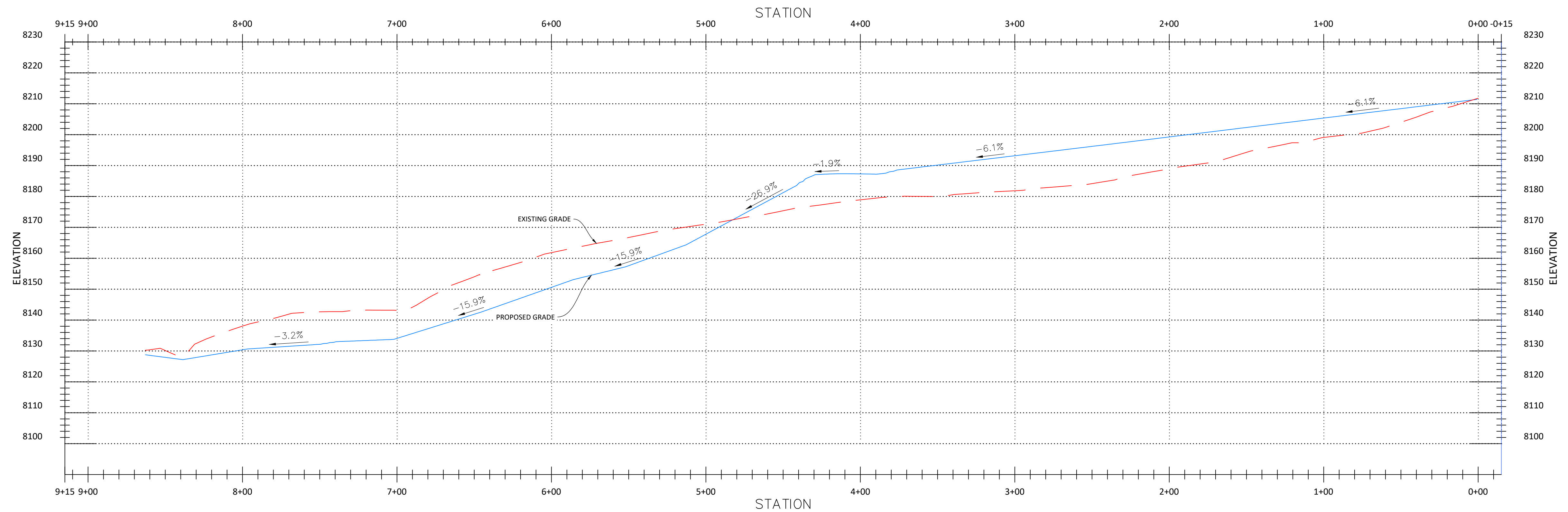

**PEDESTRIAN PATH PROFILE**

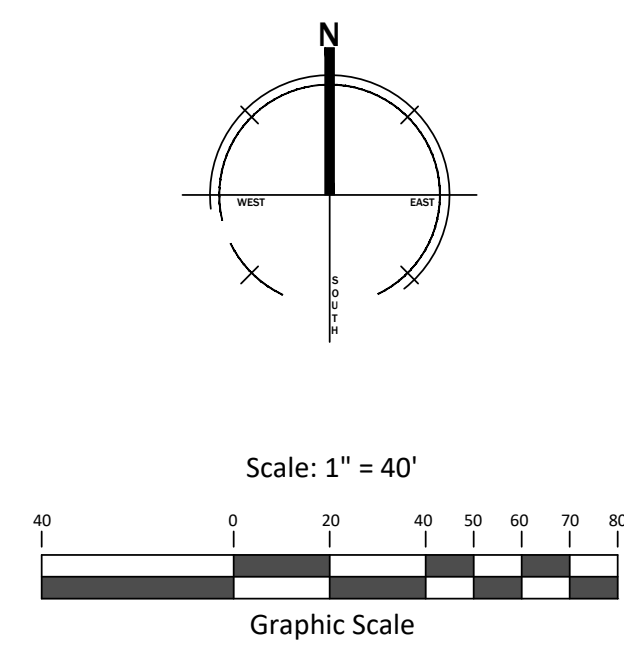

**SUBMITTAL SET**

DATE:	03/07/2024
PROJECT NO.:	23.035
REVISION	DATE
1	
2	
3	
4	
5	
6	

**PLAN & PROFILE**  
**SUNDOWN CONDOS PHASE 2**  
APPROX. 6550 NORTH POWDER MOUNTAIN ROAD  
EDEN, UTAH 84310

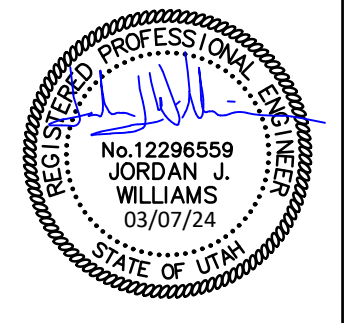

SCALE: 1"=40"

**C504**

DRAWN BY: DN

DATE: 03/07/2024  
PROJECT NO: 23.035

REVISION	DATE
1	
2	
3	
4	
5	
6	

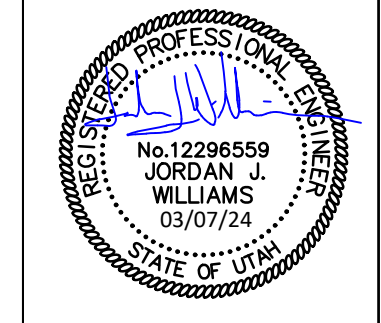

SCALE: 1"=40'

**C800**

DRAWN BY: DN

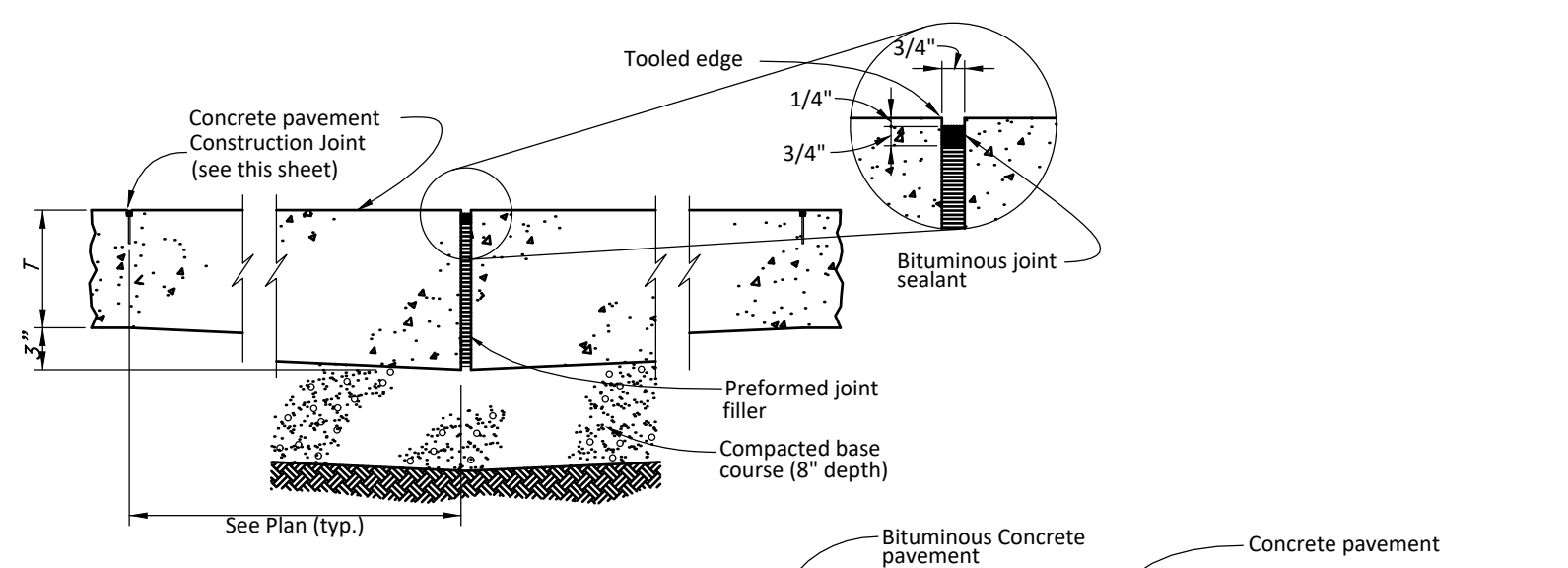

**1** Concrete Pavement  
Not to Scale

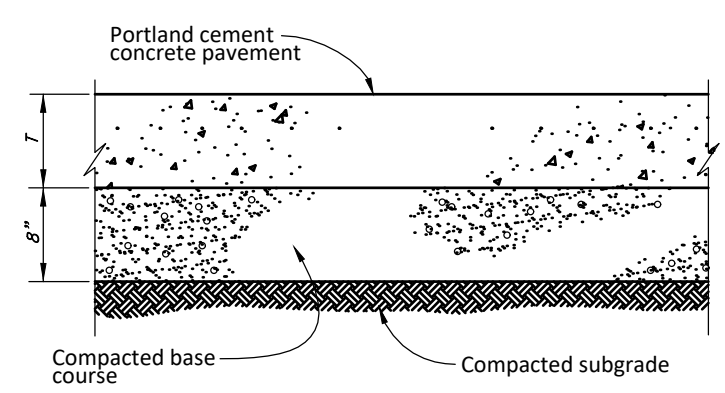

**2** Typical Bituminous Pavement Section  
Not to Scale

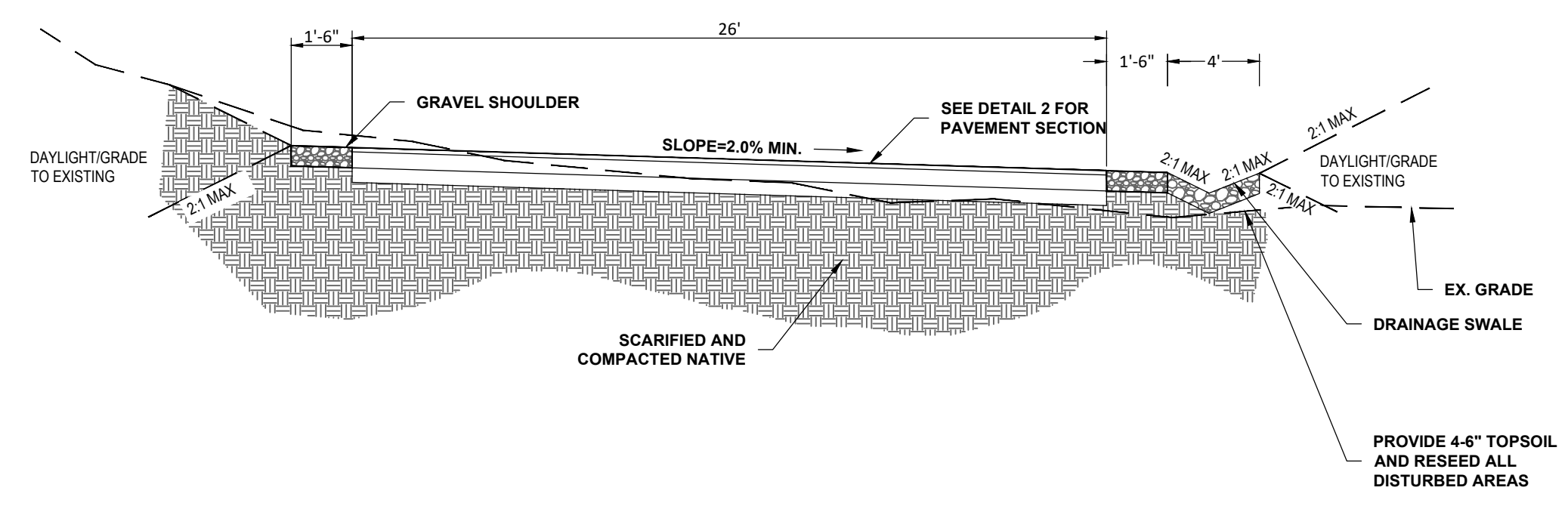

**3** Private Street Section Detail  
Not to Scale

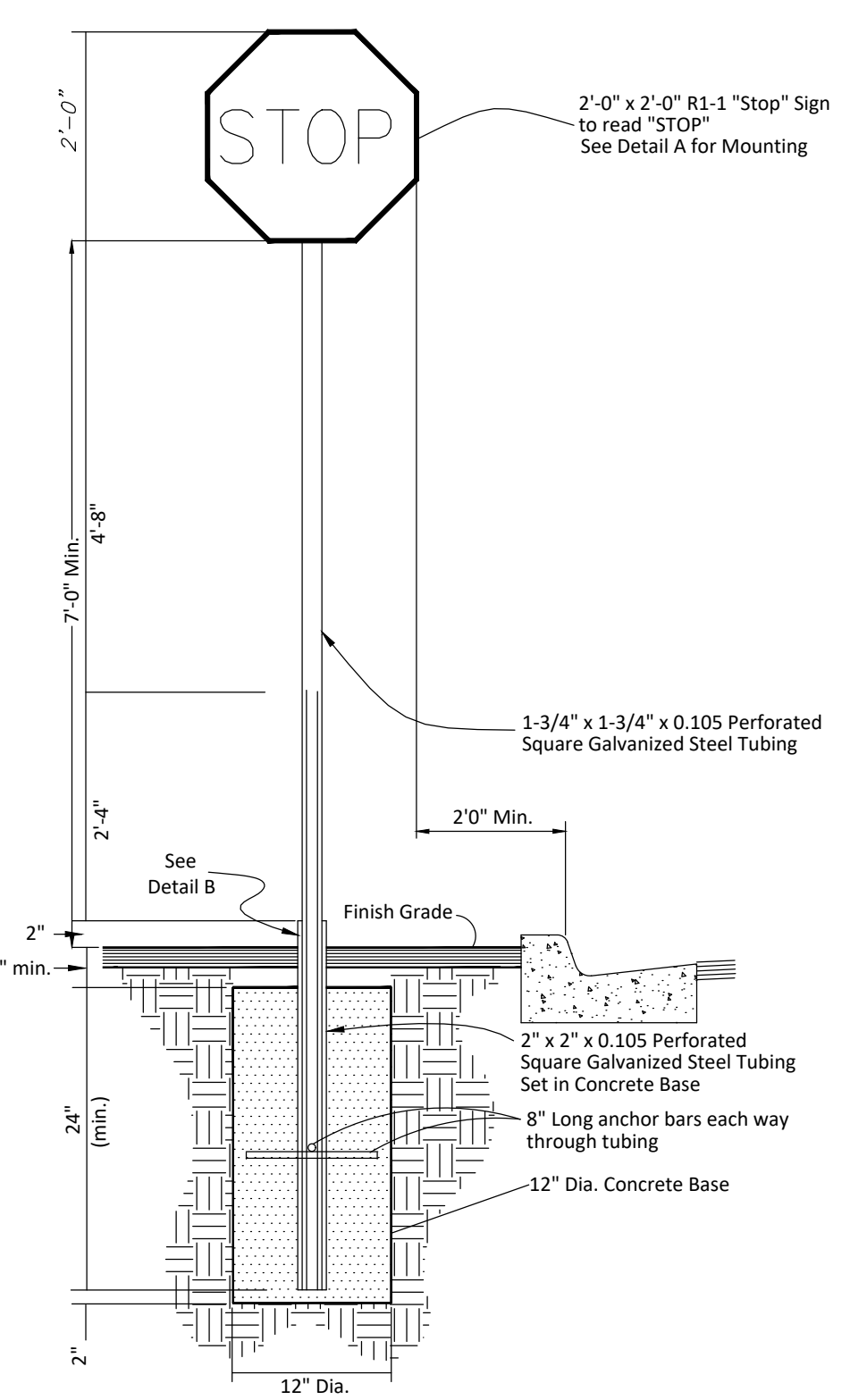
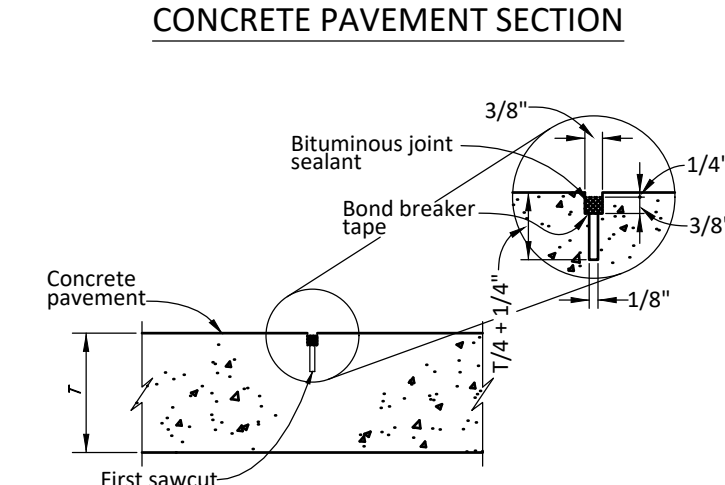

**5** Traffic Marking  
Not to Scale

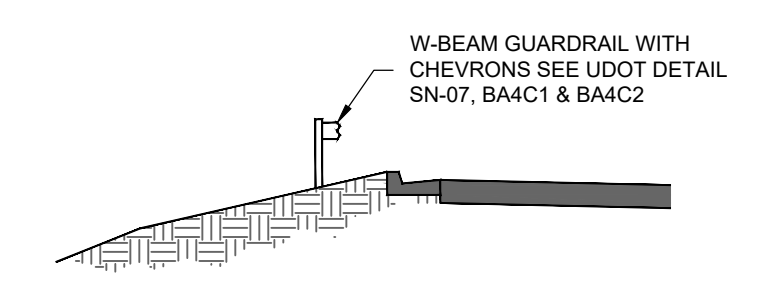

**6** Guardrail Detail  
Not to Scale



**7** Pedestrian Safety Rail  
Not to Scale

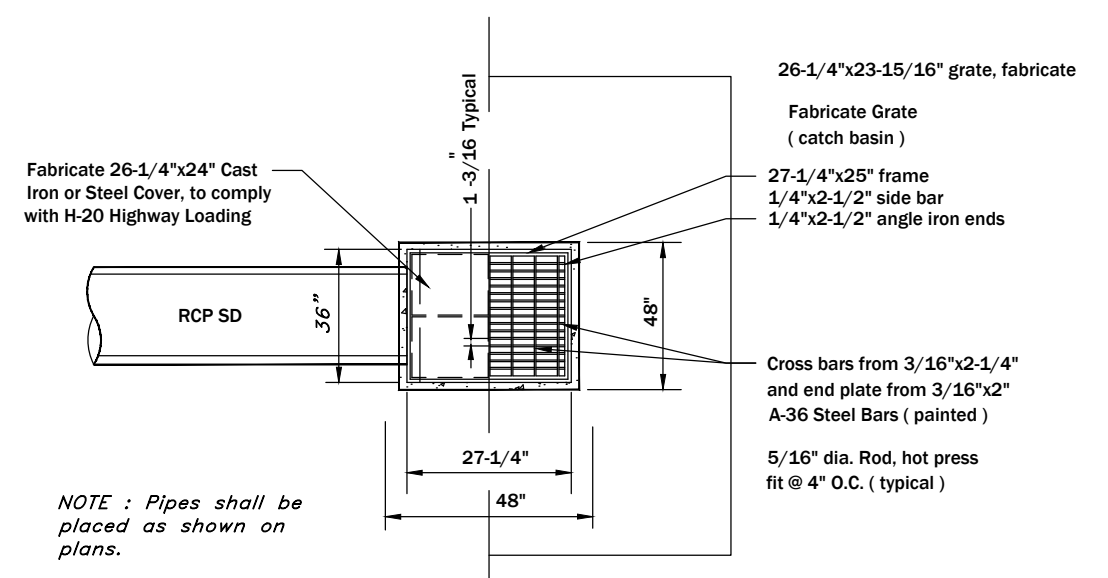
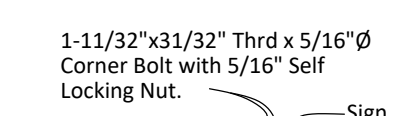

**8** 3X3 CONTROL BOX  
Not to Scale

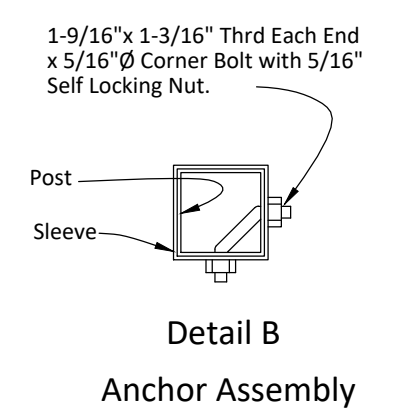

**4** Stop Sign  
Not to Scale

**CROSS-SECTION: TRENCH IN BEDROCK**

**RECOMMENDED TRENCH QUANTITIES**

PIPE DIAMETER (INCHES)	TRENCH WIDTH FOR FILL IN PIPE ZONE	RECOMMENDED MAXIMUM WIDTH FOR FILL & SURFACING ABOVE PIPE ZONE MEASURED AT TOP OF TRENCH CENTERED ON PIPE
6	10 1/2	22
8	12 1/2	24
10	14 1/2	26
12	16 1/2	28
15	19 1/2	31
18	22 1/2	34
21	25 1/2	37
24	28 1/2	40
27	31 1/2	43
30	34 1/2	46
36	40 1/2	52
42	46 1/2	58
48	52 1/2	64
54	58 1/2	70
60	64 1/2	76
66	70 1/2	82
72	76 1/2	88
78	82 1/2	94
84	88 1/2	100
90	94 1/2	106
96	100 1/2	112
102	106 1/2	118
108	112 1/2	124
114	118 1/2	130
120	124 1/2	136
126	130 1/2	142
132	136 1/2	148
138	142 1/2	154
144	148 1/2	160

**NOTES:**

- THE DISTRICT RECOMMENDS CONTRACTOR MEET ALL OF THE REQUIREMENTS ESTABLISHED FOR SAFE TRENCHING. (SEE OSHA AND USFH REQUIREMENTS, LATEST EDITIONS).
- CONTRACTOR SHALL LOCATE ALL UNDERGROUND UTILITIES BEFORE LAYING PIPE WITHIN 50' OF SAID UTILITIES WHICH MAY BE EXPOSED, DAMAGED OR CROSSED AS SHOWN ON THE DRAWINGS OR AS "TRUE STATED". THE CONTRACTOR SHALL MAKE ARRANGEMENTS WITH THE UTILITY COMPANY WITH THE UTILITY IF NECESSARY TO OBTAIN PERMISSION FROM THE DISTRICT ENGINEER TO MODIFY GRADE OF PIPELINE IN ORDER TO GO AROUND UTILITIES.
- TESTING: ALL NEW SANITARY SEWERS TO BE "TESTED" AND NECESSARY REPAIRS MADE BEFORE ACCEPTANCE. ALL LINES SHALL BE PRESSURE TESTED TO 3.5 PSI FOR 15 MINUTES. A MANHOLES OR BALL CAN BE USED TO VERIFY INFORMATION OF A PIPE AS DETERMINED FROM THE VIDEO UNLESS SPECIFIED OTHERWISE. MANHOLES SHALL BE TESTED AS DESCRIBED IN SECTION 02355.
- ALL SEWER LINES TO BE INSTALLED IN PUBLIC RIGHT-OF-WAY OR RECORDED SEWER EASEMENT UNLESS OTHERWISE APPROVED BY THE DISTRICT ENGINEER.
- WHERE COLLAPSIBLE SOILS ARE ENCOUNTERED, FURNISH, PLACE AND COMPACT IMPORTED BACKFILL MATERIALS AS REQUIRED AND AS DIRECTED.
- MIN. DEPTH SHALL BE 4" TO TOP OF PIPE. A 2" SPACING MUST BE MAINTAINED BETWEEN ALL WATER LINE PIPE CROSSINGS AND THE TOP OF THE SEWER PIPE.
- IN AREAS WHERE SEWER LATERALS ARE NEEDED TO SERVICE A BASINMENT 1" MIN. IS RECOMMENDED. IF THE SEWER LINE IS NOT 1" DEEP A NOTE MUST BE PLACED ON THE PLAN BEFORE EXCAVATING BASINMENTS. CONTRACTOR MUST VERIFY SEWER DEPTH.
- MAX. DEPTH SHALL BE 20' TO THE TOP OF THE PIPE UNLESS APPROVED OTHERWISE BY THE DISTRICT ENGINEER.

**PLAN VIEW**

**PROFILE**

**SECTION VIEW**

**NOTES:**

- DROP MANHOLE MAY ONLY BE USED IF APPROVED BY THE DISTRICT ENGINEER.
- DROP MANHOLES REQUIRED FOR ANY LINE ENTERING MANHOLE TWO FEET OR MORE ABOVE FLOORLINE OF MAIN LINE.
- MANHOLES TO CONFORM WITH STANDARD MANHOLE DETAILS (STANDARD NO. SS-2).
- ALL PIPE AND FITTINGS SHALL CONFORM TO ASTM/SORS.
- LATERAL CONNECTIONS TO MANHOLES ARE ALLOWED AS APPROVED BY DISTRICT ENGINEER. FLOW TO DROP DIRECTLY INTO FLOW LINE AND LATERAL. DO NOT EXTEND BELOW TOP OF MAINLINE PIPE.
- WHERE COLLAPSIBLE SOILS ARE ENCOUNTERED, FURNISH, PLACE AND COMPACT IMPORTED BACKFILL MATERIALS AS REQUIRED AND AS DIRECTED.
- MIN. DEPTH SHALL BE 4" TO TOP OF PIPE. A 2" SPACING MUST BE MAINTAINED BETWEEN ALL WATER LINE PIPE CROSSINGS AND THE TOP OF THE SEWER PIPE.
- IN AREAS WHERE SEWER LATERALS ARE NEEDED TO SERVICE A BASINMENT 1" MIN. DEPTH IS RECOMMENDED. IF THE SEWER LINE IS NOT 1" DEEP A NOTE MUST BE PLACED ON THE PLAN BEFORE EXCAVATING BASINMENTS. CONTRACTOR MUST VERIFY SEWER DEPTH.
- MAX. DEPTH SHALL BE 20' TO THE TOP OF THE PIPE UNLESS APPROVED OTHERWISE BY THE DISTRICT ENGINEER.

**PLAN VIEW - 45° WYE BRANCH**

**PLAN VIEW - "INSERT A TEE"**

**NOTES:**

- ALL HOUSE SERVICES SHALL BE 4" DIAMETER. COMMERCIAL AND PUBLIC SERVICES SHALL BE 6" DIAMETER UNLESS OTHERWISE SPECIFIED AND SHALL BE EXTENDED FROM MAIN LINES TO PROPERTY LINES.
- RECOMMENDED MINIMUM GRADE SHALL BE 1% FOR 6" SERVICE LINE AND 2% FOR 4" SERVICE LINE.
- ALL 90° BENDS AT CONNECTION TO MAIN MUST BE CONSTRUCTED WITH ONE 45° BEND AND 4 WYE.
- DIRECT JOSE ON IS ALLOWED WHEN CONNECTING TO EXISTING MAIN LINE. USE RUBBER BOOT AND RISE DISTRICT WITH SHALLOWS STEEL STRAP, IF REQUIRED. CORE CUT EXISTING PIPE. DO NOT BREAK OUT WITH A HAMMER.
- NOTIFY DISTRICT 24 HOURS IN ADVANCE OF ANY CONNECTION. EVERY CONNECTION TO BE INSPECTED BY DISTRICT.
- CONNECTION TO USERS TO BE DONE BY OTHERS.

**CROSS-SECTION: TYPICAL TRENCH**

**RECOMMENDED TRENCH QUANTITIES**

PIPE DIAMETER (INCHES)	TRENCH WIDTH FOR FILL IN PIPE ZONE	RECOMMENDED MAXIMUM WIDTH FOR FILL & SURFACING ABOVE PIPE ZONE MEASURED AT TOP OF TRENCH CENTERED ON PIPE
6	10 1/2	22
8	12 1/2	24
10	14 1/2	26
12	16 1/2	28
15	19 1/2	31
18	22 1/2	34
21	25 1/2	37
24	28 1/2	40
27	31 1/2	43
30	34 1/2	46
36	40 1/2	52
42	46 1/2	58
48	52 1/2	64
54	58 1/2	70
60	64 1/2	76
66	70 1/2	82
72	76 1/2	88
78	82 1/2	94
84	88 1/2	100
90	94 1/2	106
96	100 1/2	112
102	106 1/2	118
108	112 1/2	124
114	118 1/2	130
120	124 1/2	136
126	130 1/2	142
132	136 1/2	148
138	142 1/2	154
144	148 1/2	160

**NOTES:**

- THE DISTRICT RECOMMENDS CONTRACTOR MEET ALL OF THE REQUIREMENTS ESTABLISHED FOR SAFE TRENCHING. (SEE OSHA AND USFH REQUIREMENTS, LATEST EDITIONS).
- CONTRACTOR SHALL LOCATE ALL UNDERGROUND UTILITIES BEFORE LAYING PIPE WITHIN 50' OF SAID UTILITIES WHICH MAY BE EXPOSED, DAMAGED OR CROSSED AS SHOWN ON THE DRAWINGS OR AS "TRUE STATED". THE CONTRACTOR SHALL MAKE ARRANGEMENTS WITH THE UTILITY COMPANY WITH THE UTILITY IF NECESSARY TO OBTAIN PERMISSION FROM THE DISTRICT ENGINEER TO MODIFY GRADE OF PIPELINE IN ORDER TO GO AROUND UTILITIES.
- TESTING: ALL NEW SANITARY SEWERS TO BE "TESTED" AND NECESSARY REPAIRS MADE BEFORE ACCEPTANCE. ALL LINES SHALL BE PRESSURE TESTED TO 3.5 PSI FOR 15 MINUTES. A MANHOLES OR BALL CAN BE USED TO VERIFY INFORMATION OF A PIPE AS DETERMINED FROM THE VIDEO UNLESS SPECIFIED OTHERWISE. MANHOLES SHALL BE TESTED AS DESCRIBED IN SECTION 02355.
- ALL SEWER LINES TO BE INSTALLED IN PUBLIC RIGHT-OF-WAY OR RECORDED SEWER EASEMENT UNLESS OTHERWISE APPROVED BY THE DISTRICT ENGINEER.
- WHERE COLLAPSIBLE SOILS ARE ENCOUNTERED, FURNISH, PLACE AND COMPACT IMPORTED BACKFILL MATERIALS AS REQUIRED AND AS DIRECTED.
- MIN. DEPTH SHALL BE 4" TO TOP OF PIPE. A 2" SPACING MUST BE MAINTAINED BETWEEN ALL WATER LINE PIPE CROSSINGS AND THE TOP OF THE SEWER PIPE.
- IN AREAS WHERE SEWER LATERALS ARE NEEDED TO SERVICE A BASINMENT 1" MIN. IS RECOMMENDED. IF THE SEWER LINE IS NOT 1" DEEP A NOTE MUST BE PLACED ON THE PLAN BEFORE EXCAVATING BASINMENTS. CONTRACTOR MUST VERIFY SEWER DEPTH.
- MAX. DEPTH SHALL BE 20' TO THE TOP OF THE PIPE UNLESS APPROVED OTHERWISE BY THE DISTRICT ENGINEER.

**CROSS-SECTION: TYPICAL TRENCH**

**RECOMMENDED TRENCH QUANTITIES**

PIPE DIAMETER (INCHES)	TRENCH WIDTH FOR FILL IN PIPE ZONE	RECOMMENDED MAXIMUM WIDTH FOR FILL & SURFACING ABOVE PIPE ZONE MEASURED AT TOP OF TRENCH CENTERED ON PIPE
6	10 1/2	22
8	12 1/2	24
10	14 1/2	26
12	16 1/2	28
15	19 1/2	31
18	22 1/2	34
21	25 1/2	37
24	28 1/2	40
27	31 1/2	43
30	34 1/2	46
36	40 1/2	52
42	46 1/2	58
48	52 1/2	64
54	58 1/2	70
60	64 1/2	76
66	70 1/2	82
72	76 1/2	88
78	82 1/2	94
84	88 1/2	100
90	94 1/2	106
96	100 1/2	112
102	106 1/2	118
108	112 1/2	124
114	118 1/2	130
120	124 1/2	136
126	130 1/2	142
132	136 1/2	148
138	142 1/2	154
144	148 1/2	160

**NOTES:**

- THE DISTRICT RECOMMENDS CONTRACTOR MEET ALL OF THE REQUIREMENTS ESTABLISHED FOR SAFE TRENCHING. (SEE OSHA AND USFH REQUIREMENTS, LATEST EDITIONS).
- CONTRACTOR SHALL LOCATE ALL UNDERGROUND UTILITIES BEFORE LAYING PIPE WITHIN 50' OF SAID UTILITIES WHICH MAY BE EXPOSED, DAMAGED OR CROSSED AS SHOWN ON THE DRAWINGS OR AS "TRUE STATED". THE CONTRACTOR SHALL MAKE ARRANGEMENTS WITH THE UTILITY COMPANY WITH THE UTILITY IF NECESSARY TO OBTAIN PERMISSION FROM THE DISTRICT ENGINEER TO MODIFY GRADE OF PIPELINE IN ORDER TO GO AROUND UTILITIES.
- TESTING: ALL NEW SANITARY SEWERS TO BE "TESTED" AND NECESSARY REPAIRS MADE BEFORE ACCEPTANCE. ALL LINES SHALL BE PRESSURE TESTED TO 3.5 PSI FOR 15 MINUTES. A MANHOLES OR BALL CAN BE USED TO VERIFY INFORMATION OF A PIPE AS DETERMINED FROM THE VIDEO UNLESS SPECIFIED OTHERWISE. MANHOLES SHALL BE TESTED AS DESCRIBED IN SECTION 02355.
- ALL SEWER LINES TO BE INSTALLED IN PUBLIC RIGHT-OF-WAY OR RECORDED SEWER EASEMENT UNLESS OTHERWISE APPROVED BY THE DISTRICT ENGINEER.
- WHERE COLLAPSIBLE SOILS ARE ENCOUNTERED, FURNISH, PLACE AND COMPACT IMPORTED BACKFILL MATERIALS AS REQUIRED AND AS DIRECTED.
- MIN. DEPTH SHALL BE 4" TO TOP OF PIPE. A 2" SPACING MUST BE MAINTAINED BETWEEN ALL WATER LINE PIPE CROSSINGS AND THE TOP OF THE SEWER PIPE.
- IN AREAS WHERE SEWER LATERALS ARE NEEDED TO SERVICE A BASINMENT 1" MIN. IS RECOMMENDED. IF THE SEWER LINE IS NOT 1" DEEP A NOTE MUST BE PLACED ON THE PLAN BEFORE EXCAVATING BASINMENTS. CONTRACTOR MUST VERIFY SEWER DEPTH.
- MAX. DEPTH SHALL BE 20' TO THE TOP OF THE PIPE UNLESS APPROVED OTHERWISE BY THE DISTRICT ENGINEER.

5 SEWER TRENCH - PMW&S

4 SEWER DROP MANHOLE - PMW&S

3 SEWER CONNECTION - PMW&S

2 SEWER MANHOLE - PMW&S

1 SEWER TRENCH - PMW&S

**CROSS-SECTION: TYPICAL TRENCH**

**RECOMMENDED TRENCH QUANTITIES**

PIPE DIAMETER (INCHES)	TRENCH WIDTH FOR FILL IN PIPE ZONE	RECOMMENDED MAXIMUM WIDTH FOR FILL & SURFACING ABOVE PIPE ZONE MEASURED AT TOP OF TRENCH CENTERED ON PIPE
6	10 1/2	22
8	12 1/2	24
10	14 1/2	26
12	16 1/2	28
15	19 1/2	31
18	22 1/2	34
21	25 1/2	37
24	28 1/2	40
27	31 1/2	43
30	34 1/2	46
36	40 1/2	52
42	46 1/2	58
48	52 1/2	64
54	58 1/2	70
60	64 1/2	76
66	70 1/2	82
72	76 1/2	88
78	82 1/2	94
84	88 1/2	100
90	94 1/2	106
96	100 1/2	112
102	106 1/2	118
108	112 1/2	124
114	118 1/2	130
120	124 1/2	136
126	130 1/2	142
132	136 1/2	148
138	142 1/2	154
144	148 1/2	160

**NOTES:**

- INSPECTION: VALVE AND SERVICE LINE SHALL BE INSPECTED BY DISTRICT PRIOR TO BACKFILLING.
- BACKFILL: INSTALL BACKFILL IN LEFTS NOT EXCEEDING 6" AFTER COMPACTOR. COMPACT EACH LIFT TO AN AVERAGE DRY DENSITY OF 95% WITH NO DENSITY TEST RESULT LESS THAN 92%.
- ALL EXPOSED METAL PARTS SHALL BE GALVANIZED.
- FURNISH AND INSTALL CORROSIONAL HORIZONTAL BLOW HEATER LHM-10-83-33-41-1 (OR EQUAL).
- FURNISH AND INSTALL WALL MOUNT VAPOR PROOF LUMINAIRE W/ JUNCTION BOX GLOBE & GUARD AND INSTALL ELECTRICAL BOX W/ COVER PLATE.

10 WATER LATERAL - PMW&S

**CROSS-SECTION: TYPICAL TRENCH**

**RECOMMENDED TRENCH QUANTITIES**

PIPE DIAMETER (INCHES)	TRENCH WIDTH FOR FILL IN PIPE ZONE	RECOMMENDED MAXIMUM WIDTH FOR FILL & SURFACING ABOVE PIPE ZONE MEASURED AT TOP OF TRENCH CENTERED ON PIPE
6	10 1/2	22
8	12 1/2	24
10	14 1/2	26
12	16 1/2	28
15	19 1/2	31
18	22 1/2	34
21	25 1/2	37
24	28 1/2	40
27	31 1/2	43
30	34 1/2	46
36	40 1/2	52
42	46 1/2	58
48	52 1/2	64
54	58 1/2	70
60	64 1/2	76
66	70 1/2	82
72	76 1/2	88
78	82 1/2	94
84	88 1/2	100
90	94 1/2	106
96	100 1/2	112
102	106 1/2	118
108	112 1/2	124
114	118 1/2	130
120	124 1/2	136
126	130 1/2	142
132	136 1/2	148
138	142 1/2	154
144	148 1/2	160

**NOTES:**

- PLACEMENT OF CURB STOP SHALL BE A MAXIMUM OF 5 FEET OUTSIDE THE PROPERTY LINE INSIDE STREET RIGHT OF WAY.
- PROPERTY OWNERS RESPONSIBILITY FOR LEAK REPAIR SHALL BE UP TO AND INCLUDING THE SERVICE PIPE WHICH THREADS ONTO THE WATER METER. PROPERTY OWNERS RESPONSIBILITY FOR REPAIRS OTHER THAN LEAKS EXTENDS TO THE CORPORATION STOP.
- DISTRICTS RESPONSIBILITY SHALL BE THE WATER MAIN, THE CORPORATION STOP, CURB STOP, WATER METER, AND WHERE NEEDED, THE DOUBLE STRAP TAPPING SADDLE. THE DISTRICT WILL ONLY REPAIR LEAKS OCCURRING BETWEEN THE CORPORATION STOP AND THE WATER METER.
- SEE STANDARD DETAIL WT-1 AND WT-2 FOR WATER TRENCH REQUIREMENTS.
- NO LATERALS ARE TO BE INSTALLED WITHIN 9' OF BEDROCK.
- 12" THICK CLAY CUT OFF AT EACH END OF WATER SERVICE INSULATION FROM IMPERVIOUS GEOTEXTILE TO BOTTOM OF TRENCH.
- INSULATED SERVICE PIPE: SERVICE LINE ENCASED IN 8" SEAMLESS HOPE WITH CLOSED-CELL CROSS - LINKED POLYETHYLENE FOAM AND HEAT TAPE.
- 9" MINIMUM COVER REQUIRED OVER PIPE. COVER REQUIREMENT MAY BE REDUCED PER RECOMMENDATION BY APPROVED GEOTECHNICAL REPORT. IN NO CASE SHALL MINIMUM COVER OVER PIPE BE LESS THAN 7'-0". GEOTECHNICAL REPORT SHALL SPECIFICALLY ADDRESS FROST DEPTH AND PIPE FREEZING POTENTIAL.

9 WATER LATERAL - PMW&S

**CROSS-SECTION: TYPICAL TRENCH**

**RECOMMENDED TRENCH QUANTITIES**

PIPE DIAMETER (INCHES)	TRENCH WIDTH FOR FILL IN PIPE ZONE	RECOMMENDED MAXIMUM WIDTH FOR FILL & SURFACING ABOVE PIPE ZONE MEASURED AT TOP OF TRENCH CENTERED ON PIPE
6	10 1/2	22
8	12 1/2	24
10	14 1/2	26
12	16 1/2	28
15	19 1/2	31
18	22 1/2	34
21	25 1/2	37
24	28 1/2	40
27	31 1/2	43
30	34 1/2	46
36	40 1/2	52
42	46 1/2	58
48	52 1/2	64
54	58 1/2	70
60	64 1/2	76
66	70 1/2	82
72	76 1/2	88
78	82 1/2	94
84	88 1/2	100
90	94 1/2	106
96	100 1/2	112
102	106 1/2	118
108	112 1/2	124
114	118 1/2	130
120	124 1/2	136
126	130 1/2	142
132	136 1/2	148
138	142 1/2	154
144	148 1/2	160

**NOTES:**

- SIZE OF AIR VACUUM RELIEF VALVE & PIPING SHALL BE AS DETERMINED BY PROJECT ENGINEER, AND APPROVED BY DISTRICT ENGINEER.
- INSPECTION: VALVE AND SERVICE LINE SHALL BE INSPECTED BY DISTRICT PRIOR TO BACKFILLING.
- BACKFILL: INSTALL BACKFILL IN LEFTS NOT EXCEEDING 6" AFTER COMPACTOR. COMPACT EACH LIFT TO AN AVERAGE DRY DENSITY OF 95% WITH NO DENSITY TEST RESULT LESS THAN 92%.
- ALL EXPOSED METAL PARTS SHALL BE GALVANIZED.
- FURNISH AND INSTALL CORROSIONAL HORIZONTAL BLOW HEATER LHM-10-83-33-41-1 (OR EQUAL).
- FURNISH AND INSTALL WALL MOUNT VAPOR PROOF LUMINAIRE W/ JUNCTION BOX GLOBE & GUARD AND INSTALL ELECTRICAL BOX W/ COVER PLATE.

8 AIR VACUUM RELIEF VALVE - PMW&S

**CROSS-SECTION: TYPICAL TRENCH**

**RECOMMENDED TRENCH QUANTITIES**

PIPE DIAMETER (INCHES)	TRENCH WIDTH FOR FILL IN PIPE ZONE	RECOMMENDED MAXIMUM WIDTH FOR FILL & SURFACING ABOVE PIPE ZONE MEASURED AT TOP OF TRENCH CENTERED ON PIPE
6	10 1/2	22
8	12 1/2	24
10	14 1/2	26
12	16 1/2	28
15	19 1/2	31
18	22 1/2	34
21	25 1/2	37
24	28 1/2	40
27	31 1/2	43
30	34 1/2	46
36	40 1/2	52
42	46 1/2	58
48	52 1/2	64
54	58 1/2	70
60	64 1/2	76
66	70 1/2	82
72	76 1/2	88
78	82 1/2	94
84	88 1/2	100
90	94 1/2	106
96	100 1/2	112
102	106 1/2	118
108	112 1/2	124
114	118 1/2	130
120	124 1/2	136
126	130 1/2	142
132	136 1/2	148
138	142 1/2	154
144	148 1/2	160

**NOTES:**

- INSPECTION: VALVE AND SERVICE LINE SHALL BE INSPECTED BY DISTRICT PRIOR TO BACKFILLING.
- BACKFILL: INSTALL BACKFILL IN LEFTS NOT EXCEEDING 6" AFTER COMPACTOR. COMPACT EACH LIFT TO AN AVERAGE DRY DENSITY OF 95% WITH NO DENSITY TEST RESULT LESS THAN 92%.
- ALL EXPOSED METAL PARTS SHALL BE GALVANIZED.
- FURNISH AND INSTALL CORROSIONAL HORIZONTAL BLOW HEATER LHM-10-83-33-41-1 (OR EQUAL).
- FURNISH AND INSTALL WALL MOUNT VAPOR PROOF LUMINAIRE W/ JUNCTION BOX GLOBE & GUARD AND INSTALL ELECTRICAL BOX W/ COVER PLATE.

7 8" PRESSURE REDUCING VALVE - PMW&S

**CROSS-SECTION: TYPICAL TRENCH**

**RECOMMENDED TRENCH QUANTITIES**

PIPE DIAMETER (INCHES)	TRENCH WIDTH FOR FILL IN PIPE ZONE	RECOMMENDED MAXIMUM WIDTH FOR FILL & SURFACING ABOVE PIPE ZONE MEASURED AT TOP OF TRENCH CENTERED ON PIPE
6	10 1/2	22

**THRUST ON FITTINGS**

PIPE SIZE	1500	1600	1800	2000	2200
4"	185	261	412	522	722
6"	36	53.7	81.4	107.1	147.1
8"	65.8	95	142.4	184.4	255.1
10"	105.8	152	228.4	294.4	407.1
12"	153.1	218.4	332.4	428.4	584.1
14"	183.8	263.4	400.4	518.4	715.1
16"	231.8	336.3	508.4	658.4	907.1
18"	298.1	422.2	638.4	828.4	1127.1

**SAFE BEARING LOADS**

SOIL TYPE	SAFE BEARING LOAD (PSF)
SAND	1000
SAND & GRAVEL	2000
SAND GRAVEL CONCRETE WITH CLAY	3000

**SAFE BEARING LOAD FORMULA**

SAFE BEARING LOAD =  $\frac{1}{2} \times \text{THRUST ON FITTING} \times \text{SAFE BEARING CAPACITY OF SOIL}$

**NOTES:**

- WATER LINES 18 INCHES AND LARGER SHALL BE DUCTILE IRON CLASS 50.
- WATER LINES 18 INCHES AND SMALLER SHALL BE PVC AWMA CLASS 150.
- VALVES TO INCHES AND LARGER SHALL BE BUTTERFLY VALVES.
- WHENEVER POSSIBLE "HOT TAP" CONNECTIONS REQUIRED - HOT TAP VALVE TO BE SUPPORTED DURING CONNECTION. CONNECTION TO BE MADE BY DISTRICT STAFF IN ADVANCEMENT OF MAIN CONNECTION.
- PIPE ONE SHALL BE BACKFILLED WITH 3" GRAVEL MATERIAL.
- TRACING WIRE TO BE BROUGHT OUTSIDE OF BOTTOM PORTION OF VALVE BOX AND INSET TOP TO SURFACE.
- FURNISH AND INSTALL POLY W/WRAP ON DUCTILE IRON PIPE. POLY W/WRAP MAY BE OLEFINES OR OTHERS AS APPROVED BY DISTRICT ENGINEER.
- WHERE COLLAPSEABLE SOILS ARE ENCOUNTERED, FURNISH PLACE AND COMPACT BACKFILL MATERIAL WITHIN 18" OF PIPE AND AS DIRECTED.
- SEE DMS FOR PIPE BEDDING SPECIFICATIONS.
- 12" MINIMUM COVER REQUIRED OVER PIPE. COVER REQUIREMENT MAY VARY BY DISTRICT STAFF IN ADVANCEMENT OF MAIN CONNECTION.
- PIPE ONE SHALL BE BACKFILLED WITH 3" GRAVEL MATERIAL.
- TRACING WIRE TO BE BROUGHT OUTSIDE OF BOTTOM PORTION OF VALVE BOX AND INSET TOP TO SURFACE.

1 WATERLINE TRENCH - PMW&S

**UNIMPROVED TERRAIN TRENCH SECTION**

**IMPROVED TERRAIN TRENCH SECTION**

**CLASS A PIPE BEDDING**

PIPE DIAMETER	MINIMUM WIDTH	MAXIMUM WIDTH
4"	12"	24"
6"	18"	24"
8"	24"	24"
10"	30"	24"
12"	36"	24"
14"	42"	24"
16"	48"	24"

**CLASS B PIPE BEDDING**

PIPE DIAMETER	MINIMUM WIDTH	MAXIMUM WIDTH
4"	12"	24"
6"	18"	24"
8"	24"	24"
10"	30"	24"
12"	36"	24"
14"	42"	24"
16"	48"	24"

**NOTES:**

- BACKFILL MATERIAL AT NEAR OPTIMUM MOISTURE SHALL BE PLACED IN HORIZONTAL LAYERS NOT TO EXCEED 8" AND COMPACTED TO 95% DENSITY AS DESCRIBED IN THE SPECIFICATIONS. SIDE OF GRAVEL SHALL BE AS SPECIFIED.
- BACKFILL MATERIAL AT NEAR OPTIMUM MOISTURE SHALL BE PLACED IN HORIZONTAL LAYERS NOT TO EXCEED 8" AND COMPACTED TO 95% DENSITY AS DESCRIBED IN THE SPECIFICATIONS. SIDE OF GRAVEL SHALL BE AS SPECIFIED.
- BACKFILL MATERIAL AT NEAR OPTIMUM MOISTURE SHALL BE PLACED IN HORIZONTAL LAYERS NOT TO EXCEED 8" AND COMPACTED TO 95% DENSITY AS DESCRIBED IN THE SPECIFICATIONS. SIDE OF GRAVEL SHALL BE AS SPECIFIED.
- BACKFILL MATERIAL AT NEAR OPTIMUM MOISTURE SHALL BE PLACED IN HORIZONTAL LAYERS NOT TO EXCEED 8" AND COMPACTED TO 95% DENSITY AS DESCRIBED IN THE SPECIFICATIONS. SIDE OF GRAVEL SHALL BE AS SPECIFIED.

2 PIPE BEDDING - PMW&S

**SECTION VIEW**

**PLAN VIEW**

**NOTES:**

- HYDRANT SHALL BE "TRAFFIC" TYPE WITH A REPLACEABLE BRICK-ARMY LIFT IMMEDIATELY ABOVE CURB.

3 FIRE HYDRANT - PMW&S

**NOTES:**

- DISTRICT TO BE GIVEN 24 HOUR NOTICE BEFORE LOOPING ANY WATERLINE.

4 WATER LOOP - PMW&S

**NOTES:**

- METER BOXES SHALL BE 18" DIA BY 96" DEEP MUELLER-THERMAL-COL PVC BOXES FOR 1" SINGLE METERS (MUELLER 3300S1806F888).
- POLYETHYLENE PIPE FOR WATER SERVICES SHALL BE 3408 TUBING, SDR9. COPPER TUBING SIZE AND NSF APPROVED FOR POTABLE WATER.
- METER SHALL BE INSTALLED IN HORIZONTAL ALIGNMENT, WITH METER FACING UP, ONLY.
- ALL PIPE, FITTING, AND VALVES SHALL COMPLY WITH NSF STANDARD NO 14 FOR USE WITH POTABLE WATER.
- THE CUSTOMER IS RESPONSIBLE FOR PROPERLY SIZING THE SERVICE TO DELIVER FLOWS REQUIRED FOR FIRE SPRINKLER SYSTEMS. THE SERVICE FROM THE METER TO THE BUILDING CAN BE UPSCALED FROM 1" DIAMETER, IF NECESSARY, CONNECTING FIRE SPRINKLER LINES TO THE 2" SERVICE BEFORE THE METER MAY BE APPROVED BY THE DISTRICT ENGINEER ONLY IF THE REQUIRED FIRE SPRINKLER CANNOT BE DELIVERED THROUGH THE METER.
- THE DEVELOPER IS RESPONSIBLE FOR INSTALLATION OF THE SERVICE FROM THE MAIN TO THE METER BOX, INCLUDING THE SERVICE SADDLE, COPR STOP, CURB STOP BOX, AND METER BOX.
- BASED UPON OBSERVATIONS DURING WATER CONNECTIONS, THE DISTRICT HAS DETERMINED THAT IF 8" MIN OF COVER OVER WATER MAIN AND SERVICES IS REQUIRED TO PROTECT AGAINST FREEZING.

5 METER PIT - PMW&S

**NOTES:**

- INSPECTION: METER BOX AND SERVICE LINE SHALL BE INSPECTED BY DISTRICT PRIOR TO BACKFILLING.
- BACKFILL: INSTALL BACKFILL IN LIFTS NOT EXCEEDING 8" AFTER COMPACTION, COMPACT EACH LIFT TO AN AVERAGE DRY DENSITY OF 97% WITH NO DENSITY TEST RESULT LESS THAN 92%.
- WATER METER SHALL BE PROVIDED BY DISTRICT.
- PLACEMENT: ALL METERS ARE TO BE INSTALLED WITHIN 7 FEET OF THE PROPERTY LINE (STREET SIDE) AND MUST BE PLACED NEAR MIDPOINT OF THE LOT AND MUST NOT BE LOCATED IN A DRIVEWAY.
- PIPE SERVICES SHALL BE MADE USING A COMPRESSION FITTING, MUELLER 110 COMPRESSION CONNECTION (MUELLER H-15423).
- CONTRACTOR SHALL SUPPLY ALL MATERIALS AND LABOR, EXCLUDING THE WATER METER.
- NEW SUBDIVISIONS SHALL HAVE WATER SERVICE STUBBED TO A POINT APPROXIMATELY 1 (ONE) FOOT BEYOND UTILITY EASEMENT.
- 1 1/2"-HIGH METER INSTALLATION TO BE SIMLAR, USING 1 1/2"-HIGH METER, PIPE, FITTINGS AND SETTER.
- PROVIDE AND INSTALL ELECTRICAL CONDUIT TO NEAREST TRANSFORMER.
- FURNISH AND INSTALL CHROMALOX HORIZONTAL BLOW HEATER LHM-05-83-41-1 (OR EQUAL).
- FURNISH AND INSTALL WALL MOUNT VAPOR PROOF LUMINAIRE W/ JUNCTION, BOX GLOBE & GUARD AND INSTALL ELECTRICAL BOX W/ COVER PLATE.

6 2" WATER METER - PMW&S

**BACKFLOW PREVENTER IN BASEMENT INSTALLATION**

**BACKFLOW PREVENTER IN BUILDING INSTALLATION**

**BACKFLOW PREVENTER PLAN VIEW**

**NOTES:**

- TO BE USED WHEN SERVICE IS CONNECTED TO CULINARY WATER SYSTEM.
- TO BE USED WHEN SERVICE IS CONNECTED TO CULINARY WATER SYSTEM.

7 BACKFLOW PREVENTER - PMW&S

**BACKFLOW PREVENTER IN BASEMENT INSTALLATION**

**BACKFLOW PREVENTER IN BUILDING INSTALLATION**

**BACKFLOW PREVENTER PLAN VIEW**

**NOTES:**

- TO BE USED WHEN SERVICE IS CONNECTED TO CULINARY WATER SYSTEM.
- TO BE USED WHEN SERVICE IS CONNECTED TO CULINARY WATER SYSTEM.

8 BACKFLOW PREVENTER - PMW&S

**BACKFLOW PREVENTER IN BASEMENT INSTALLATION**

**SERVICE BACKFLOW PREVENTER IN BUILDING INSTALLATION**

**SERVICE BACKFLOW PREVENTER PLAN VIEW**

**NOTES:**

- TO BE USED WHEN SERVICE IS CONNECTED TO CULINARY WATER SYSTEM.
- TO BE USED WHEN SERVICE IS CONNECTED TO CULINARY WATER SYSTEM.

9 SERVICE BACKFLOW PREVENTER - PMW&S

**BACKFLOW PREVENTER IN BASEMENT INSTALLATION**

**SERVICE BACKFLOW PREVENTER IN BUILDING INSTALLATION**

**SERVICE BACKFLOW PREVENTER PLAN VIEW**

**NOTES:**

- TO BE USED WHEN SERVICE IS CONNECTED TO CULINARY WATER SYSTEM.
- TO BE USED WHEN SERVICE IS CONNECTED TO CULINARY WATER SYSTEM.

10 SERVICE BACKFLOW PREVENTER - PMW&S