

VICINITY MAP Not to Scale

NOTES

- 1. 10' Public Utility and Drainage Easements along the Front Property line and across all of Parcels A-H.
2. Due to the topography and the location of this subdivision all owners will accept responsibility for any storm water runoff from the road adjacent to this property until curb and gutter is installed.
3. Lowest Finished Floor Elevation (LFFE) to be a maximum of 3.0' below Existing Grade or 4.0' below the Top Back of curb at the Lowest corner of the Lot whichever is higher.

BENCHMARK

Brass Cap Section Monument located in the South East Quarter Corner of Section 16, T6N, R2W, SLB&M, U.S. Survey (Found Brass Cap Monument in good condition dated 1963).

Legend: Monument to be set, Found Centerline Monument, Radial Line, Non-Radial Line, Public Utility Easement, Public Utility & Drainage Easement, Fence, Buildable Area, Floodplain, Easement, Buildable area, Bank of Slough, Existing Boundary, Set Hub & Tack, Nail will be set in Curb, Extension of Property, Section Corner.

Riverbend Farms Phase 2

A Cluster Subdivision
A part of Section 15 and Section 16, T6N, R2W, SLB&M, U.S. Survey,
Weber County, Utah
March 2024

NARRATIVE

This Subdivision plot was requested by Edward Gramp for the purpose of creating 47 residential Lots, 1 Agricultural preservation parcel (L) and 2 common Area parcels (I and J).
Basis of Bearings for this Subdivision is N 89°23'10" W between the Reference Monument for the Southeast corner of Section 16 and the reference monument for the South east corner of Section 15.
Complete boundary retracement and exterior boundary details can be found on a Survey filed with Weber County Surveying department as Filing #7248.
Property corners were monumented as depicted on this plot.

ACKNOWLEDGMENT

State of Utah
County of Weber
The foregoing instrument was acknowledged before me this ___ day of 2024 by Bryan Bayless
Residing At:
Commission Number:
Commission Expires:
A Notary Public commissioned in Utah
Print Name

BOUNDARY DESCRIPTIONS

A part of the Southeast Quarter of Section 16, and the West Half of Section 15, Township 6 North Range 2 West, Salt Lake Base and Meridian.
Beginning at a point on the Southeast corner of Open Space G, Riverbend Farms Phase 1 said point being 278.56 feet South 89°19'36" East along the Calculated Section Line and 868.69 feet North 0°40'24" East from the Southeast corner of said Section 16; and running thence South 89°07'36" West 628.47 feet to the Southeast corner of Riverbend Farms Phase 1; thence nine (9) courses along the Eastern Boundary of said Phase 1 as follows: (1) North 12°03'54" East 116.50 feet to a point of non-tangent curvature, (2) Southeasterly along the arc of a 333.00 foot radius curve to the left a distance of 58.14 feet (Central Angle equals 10°00'12" and Long Chord bears South 82°52'58" East 58.07 feet) (3) North 02°06'56" East 66.00 feet; (4) North 09°59'56" East 332.82 feet; (5) North 10°08'45" East 247.85 feet; (6) North 10°09'12" East 242.74 feet; (7) North 07°24'45" East 66.00 feet; (8) North 82°37'58" West 51.23 feet; and (9) North 07°22'02" East 104.62 feet; thence South 81°52'12" East 169.95 feet; thence South 83°35'30" East 443.95 feet to a point on the West boundary line of Open Space G; thence South 09°32'27" West 1091.06 feet along said West Boundary line to the Point of Beginning.
Together with:
Beginning at a point on the East Boundary of Open Space G, Riverbend Farms Phase 1 said point being 633.05 feet South 89°19'36" East along the Calculated Section Line and 2037.60 feet North 0°40'24" East from the Southeast corner of said Section 16; and running thence four (4) courses along the West and North Boundaries of said Parcel G as follows: (1) North 00°43'36" East 10.00 feet; (2) South 89°16'24" East 52.52 feet; (3) North 04°50'20" East 304.09 feet; and (4) North 85°09'40" West 230.87 feet; thence North 04°50'20" East 129.02 feet; thence North 07°17'55" East 251.26 feet; thence North 05°35'21" East 791.88 feet; thence North 28°00'25" East 307.05 feet; thence South 60°01'10" East 624.80 feet; thence South 07°11'23" West 222.70 feet; thence North 85°39'07" West 150.61 feet to a point on a non-tangent curve to the left having a radius of 265.80 feet; thence along said arc a distance of 170.99 feet, Central Angle equals 36°51'31" and Long Chord bears South 72°18'54" West 168.06 feet to a point of non-tangency; thence South 46°24'03" West 184.50 feet; thence South 40°28'27" West 102.35 feet to a point of curvature to the left having a radius of 100.00 feet; thence Southerly along said arc 140.66 feet, Central Angle equals 80°35'22" and Long Chord bears South 00°10'46" West 129.34 feet; thence South 40°06'55" East 107.11 feet; thence South 58°17'58" East 95.63 feet; thence South 56°16'08" East 107.75 feet; thence South 47°45'12" East 14.77 feet; thence South 00°09'34" West 403.63 feet; thence North 89°16'24" West 526.00 feet to the POINT OF BEGINNING.

Containing 34.303 acres, more or less.

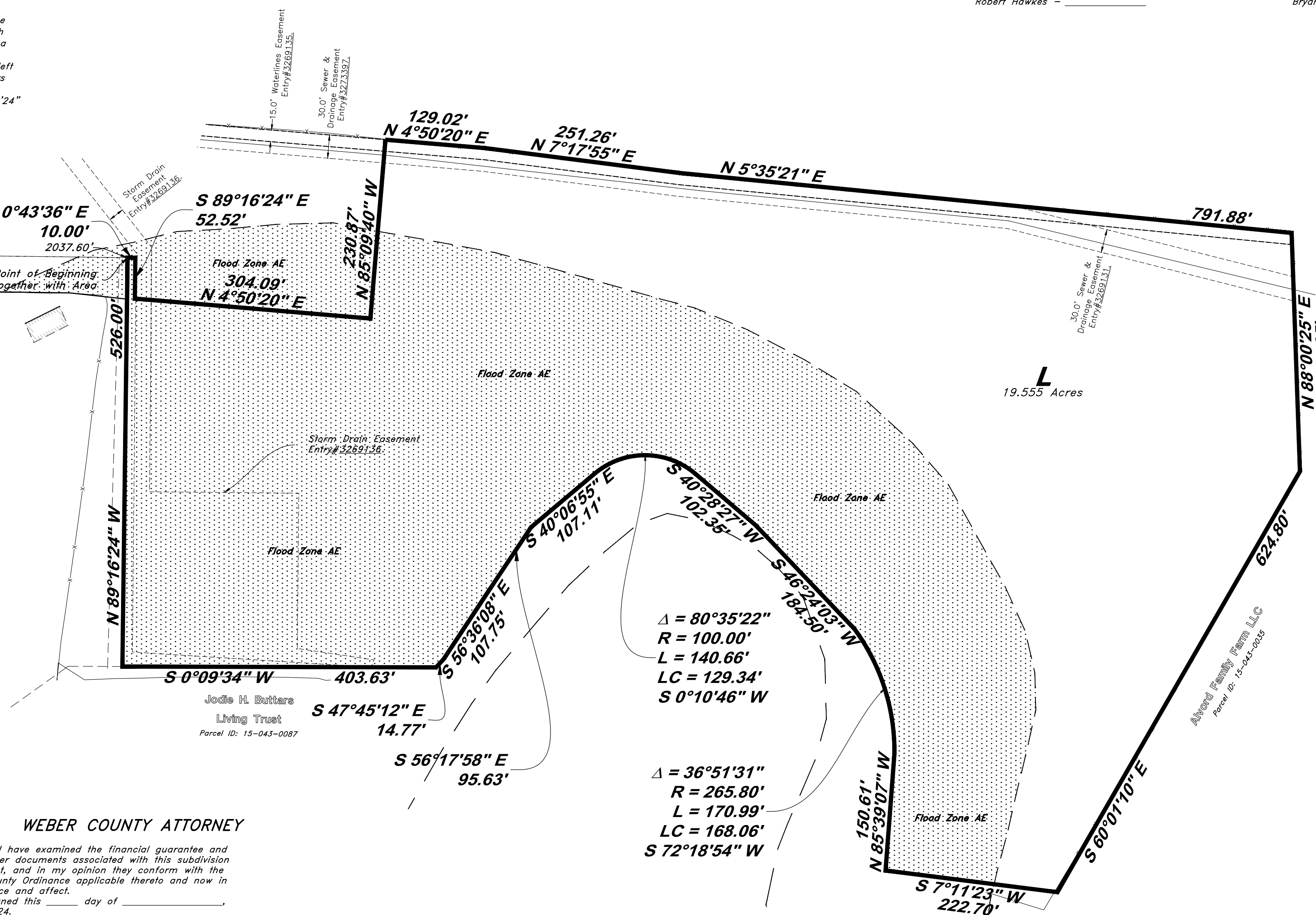
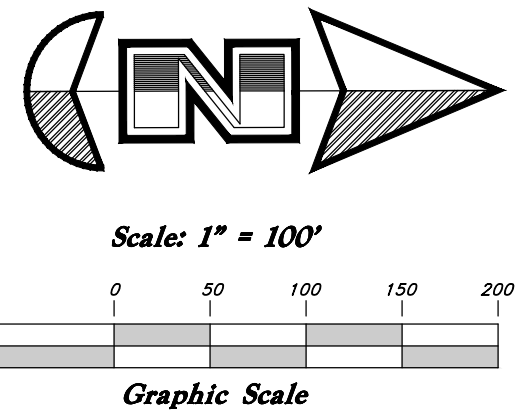
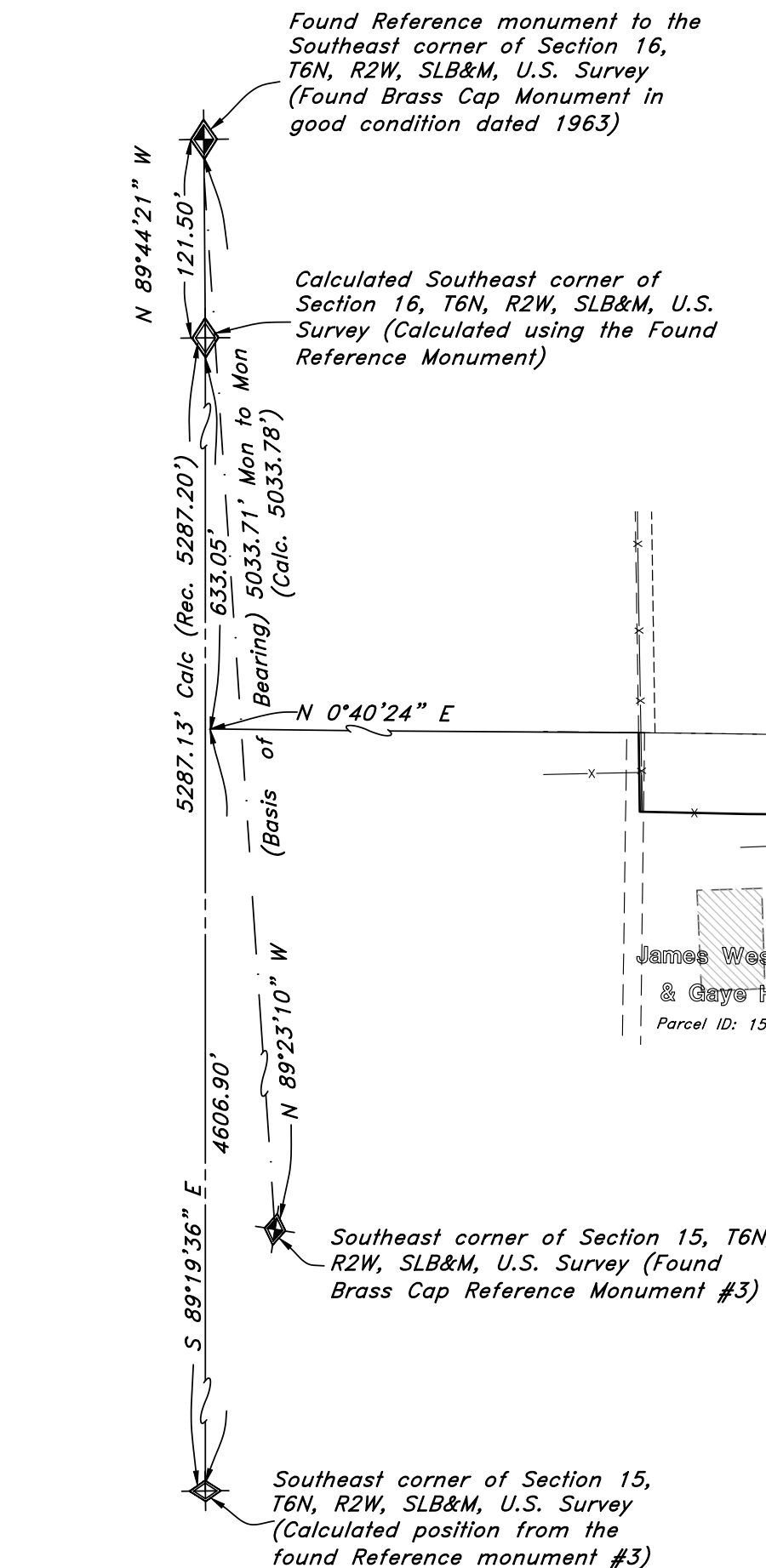

SURVEYOR'S CERTIFICATE
I, Andy Hubbard, do hereby certify that I am a Professional Land Surveyor in the State of Utah, and that I hold License No. 6242920 in accordance with Title 58, Chapter 22, of the Professional Engineers and Professional Land Surveyors Licensing Act. I also certify that I have completed a survey of the property described herein in accordance with Section 17-23-17 and that I have verified all measurements shown hereon this plat of Riverbend Farms Phase 2 in Weber County, Utah and that it has been correctly drawn to the designated scale and is a true and correct representation of the following description of lands included in said subdivision, based on data compiled from records in the Weber County Recorder's Office. Monuments have been found or placed as represented on this plat. I furthermore certify that all lots within this Subdivision hereby meet all current lot width and area requirements of the Weber County Zoning Ordinance.
Signed this ___ day of ___, 2024
6242920 License No. Andy Hubbard

OWNERS DEDICATION

We the undersigned owners of the herein described tract of land, do hereby set apart and subdivide the same into lots and streets as shown on the plat and name said tract Riverbend Farms Phase 2 Subdivision and do hereby dedicate and grant to Weber County a perpetual right and easement on and over the agriculture preservation parcel L, to guarantee to Weber County that the agriculture preservation parcels remain open and undeveloped except for approved agricultural, recreational, Secondary Water and storm water purposes except to be used and maintained by the owner of said parcel(s) for approved agricultural purposes, and Secondary Water purposes, and also do grant and dedicate a perpetual right and easement over, upon and under the lands designated hereon as Common Open Space and/or public utility easements, the same to be used for the maintenance and operation of Sanitary Sewer lines and Structures, Storm Drainage Lines and Structures and/or public utility service lines and storm drainage facilities, whichever is applicable as may be authorized by the governing authority, we also dedicate and grant to Weber County, all those parts or portions of said tract designated as Trail Easement, the same to be used as a public trail for pedestrian ingress and egress as may be authorized by the governing authority.
We also do hereby dedicate, grant and convey to the Owners Association the Parcels referred to as Common Open Spaces parcels I, through J, and also dedicate and grant a perpetual right and easement over, upon and under the lands designated hereon as Open Spaces I through J and Agricultural Parcel L for Secondary Water Facilities, Storm Water Detention, Agricultural uses and purposes. The same to be used for the maintenance and operation of storm drainage facilities, Secondary Water facilities as applicable as may be authorized by the governing authority, with no residential buildings or structures being erected within such parcels as shown hereon which is defined in the Covenants, Conditions, and Restrictions (CC&R's) for this development, and additionally dedicate and convey to Weber County a perpetual open space easement on, under, and over all parcels and areas denoted as open space parcels or areas to guarantee to the public that those parcels and areas remain open and undeveloped in a manner consistent with the approved open space plan.
We also grant and dedicate a perpetual right and easement over, upon and under the lands designated hereof as public utility and drainage easements the same to be used for the installation maintenance and operation of public utility service lines, storm drainage facilities, irrigation canals or for the perpetual preservation of water channels in their natural state whichever is applicable as may be authorized by the governing authority, with no buildings or structures being erected within such easements; and further dedicate to public use all those parts or portions of said tract of land designated as streets, the same to be used as public thoroughfares.
Signed this ___ Day of ___, 2024.

Robert Hawkes Real Estate LLC
Riverbend Holdings, LLC
Robert Hawkes
Bryan Bayless
5617 South 1475 East, SOUTH OGDEN UT 84403

WEBER COUNTY COMMISSION ACCEPTANCE

This is to certify that this subdivision plat, the dedication of streets and other public ways and financial guarantee of public improvements associated with this subdivision, thereon are hereby approved and accepted by the Commissioners of Weber County, Utah. Signed this ___ day of ___, 2024.

AGRICULTURAL NOTE

Agriculture is the preferred use in the agricultural zones. Agricultural operations as specified in the Land Use Code for a particular zone are permitted at any time including the operation of farm machinery and no allowed agricultural use shall be subject to restrictions on the basis that it interferes with activities of future residents of this subdivision.

WEBER COUNTY PLANNING COMMISSION APPROVAL

This is to certify that this subdivision plat was duly approved by the Weber County Planning Commission. Signed this ___ day of ___, 2024. Chairman, Weber County Planning Commission

WEBER COUNTY SURVEYOR

I hereby certify that the Weber County Surveyor's Office has reviewed this plat and all conditions for approval by this office have been satisfied. The approval of this plat by the Weber County Surveyor does not relieve the Licensed Land Surveyor who executed this plat from the responsibilities and/or liabilities associated therewith. Signed this ___ day of ___, 2024.

WEBER COUNTY ENGINEER

I hereby certify that the required public improvement standards and drawings for this subdivision conform with County standards and the amount of the financial guarantee is sufficient for the installation of these improvements. Signed this ___ of ___, 2024.

WEBER COUNTY ATTORNEY

I have examined the financial guarantee and other documents associated with this subdivision plat, and in my opinion they conform with the County Ordinance applicable thereto and now in force and effect. Signed this ___ day of ___, 2024. Weber County Attorney

GREAT BASIN ENGINEERING logo and address: 5746 SOUTH 1475 EAST OGDEN, UTAH 84403. Phone: (801)394-4515. Fax: (801)392-7544.

DEVELOPER: Riverbend Farms Community LLC, C/O Ed Gramp, 1493 East Ridgeline Drive #520, Ogden, Utah 84405. SURVEYOR: Great Basin Engineering, Inc., c/o Andy Hubbard, PLS, 5746 South 1475 East Suite 200, Ogden, Utah 84405.

Virgil C. Howe, Revocable Trust, Parcel ID: 15-043-0024

WEBER COUNTY RECORDER table with fields for ENTRY NO., FILED FOR RECORD AND RECORDED, AT, IN BOOK, OF OFFICIAL RECORDS, PAGE, RECORDED FOR, WEBER COUNTY RECORDER, BY, DEPUTY.

Property line Curve Data

Curve #	Delta	Radius	Length	Chord Direction	Chord Length
C1	10°00'12"	333.00'	58.14'	S 82°52'58" E	58.07'
C2	2°59'20"	333.00'	17.37'	S 89°22'44" E	17.37'
C3	96°19'02"	10.50'	17.65'	S 42°42'53" E	15.64'
C4	7°13'09"	407.85'	51.39'	S 2°17'07" W	51.35'
C5	9°03'07"	400.00'	63.19'	N 3°39'09" E	63.13'
C6	1°20'58"	400.00'	9.42'	N 8°51'12" E	9.42'
C7	84°40'38"	10.50'	15.52'	N 54°32'04" E	14.14'
C8	84°39'14"	10.50'	15.51'	N 35°27'56" W	14.14'
C9	87°50'21"	10.50'	16.10'	S 53°26'51" W	14.57'
C10	92°29'36"	10.50'	16.95'	S 36°23'10" E	15.17'
C11	4°43'09"	230.00'	18.94'	S 7°30'03" W	18.94'
C12	6°00'52"	230.00'	24.14'	S 2°08'02" W	24.13'
C13	90°00'00"	10.50'	16.49'	S 44°07'36" W	14.85'
C14	2°59'20"	267.00'	13.93'	N 89°22'44" W	13.93'
C15	90°00'00"	10.50'	16.49'	N 45°52'24" W	14.85'
C16	79°35'55"	10.50'	14.59'	S 49°19'38" W	13.44'
C17	92°09'39"	10.50'	16.89'	S 36°33'09" E	15.13'
C18	87°30'24"	10.50'	16.04'	N 53°36'50" E	14.52'
C19	10°44'02"	170.00'	31.85'	N 4°29'37" E	31.80'

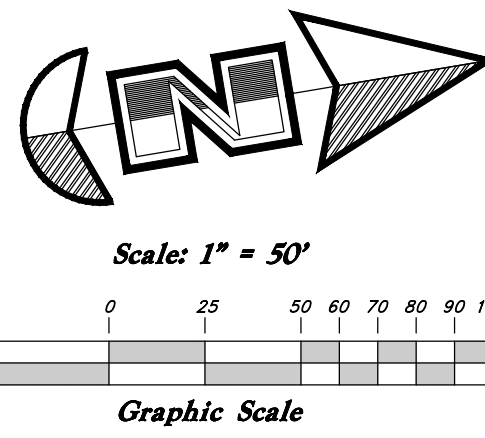

Center line Curve Data

Curve #	Delta	Radius	Length	Chord Direction	Chord Length
C100	2°59'20"	300.00'	15.65'	S 89°22'44" E	15.65'
C101	10°24'05"	433.00'	78.61'	N 4°19'38" E	78.50'
C102	2°10'25"	350.00'	13.28'	S 81°32'46" E	13.28'
C103	10°44'02"	200.00'	37.47'	N 4°29'37" E	37.41'

Riverbend Farms Phase 2

A Cluster Subdivision
A part of Section 15 and Section 16, T6N, R2W, SLB&M, U.S. Survey,
Weber County, Utah
March 2024

- Legend**
- Monument to be set
 - Found Centerline Monument
 - (Rad.) Radial Line
 - (N/R) Non-Radial Line
 - PUE Public Utility Easement
 - PU&DE Public Utility & Drainage Easement
 - Fence
 - Buildable Area
 - Floodplain
 - Easement
 - Buildable area
 - Bank of Slough
 - Existing Boundary
 - Set Hub & Tack
 - A Nail will be set in Curb
 - Extension of Property
 - Set 5/8" x 24" Long Rebar & Cap w/ Lathe
 - Section Corner

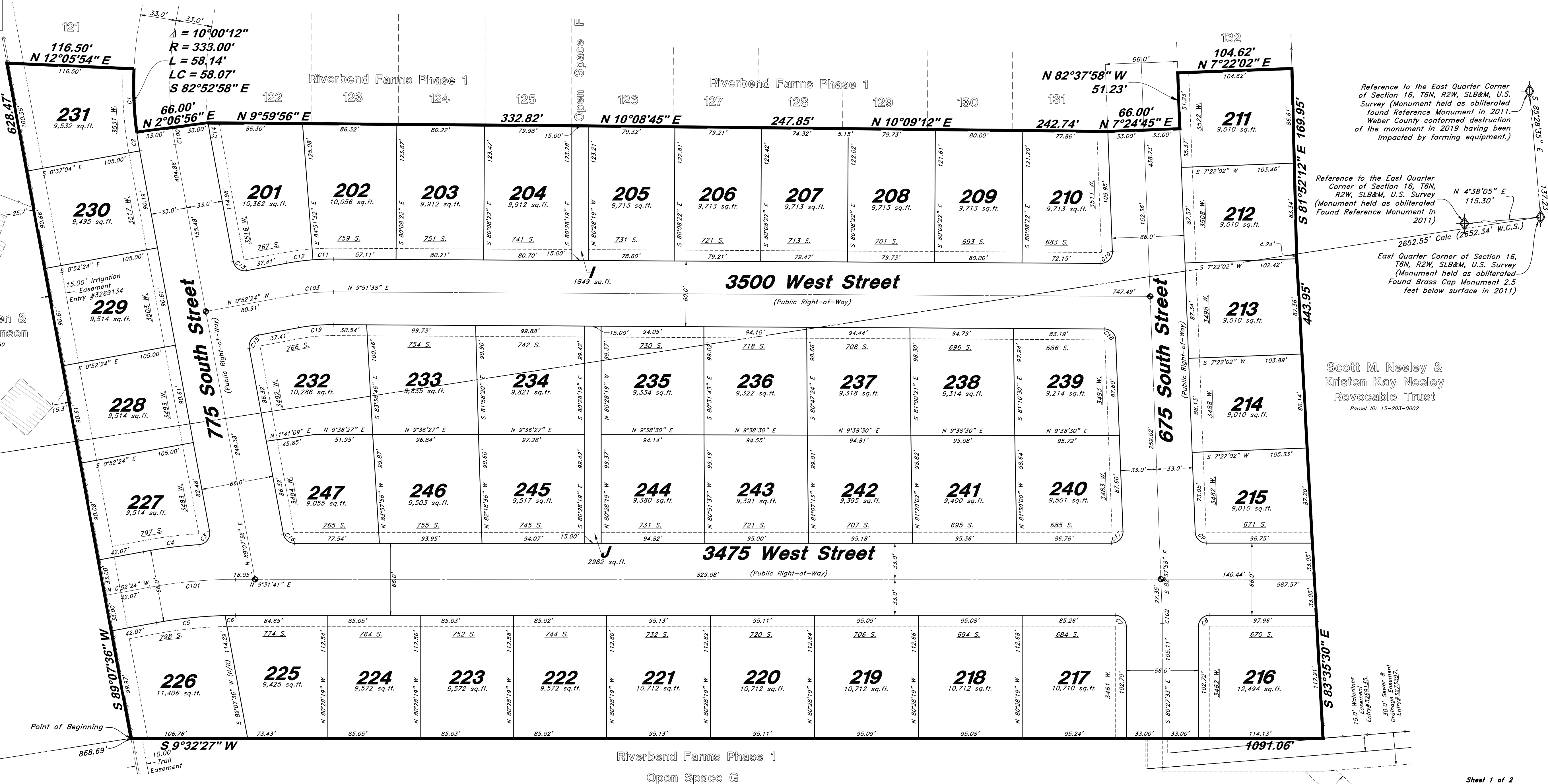

Kent A. Hansen & Kathryn A. Hansen
Parcel ID: 15-045-0080

Scott M. Neeley & Kristen Kay Neeley
Revocable Trust
Parcel ID: 15-203-0002

GREAT BASIN ENGINEERING
5746 SOUTH 1475 EAST OGDEN, UTAH 84403
MAIN (801)394-4515 S.L.C (801)521-0222 FAX (801)392-7544
WWW.GREATBASINENGINEERING.COM

SURVEYOR:
Great Basin Engineering, Inc.
c/o Andy Hubbard, PLS
5746 South 1475 East Suite 200
Ogden, Utah 84405
(801) 394-4515

Sheet 1 of 2

WEBER COUNTY RECORDER

ENTRY NO. _____ FILED FOR RECORD AND
RECORDED _____ AT _____
IN BOOK _____ OF OFFICIAL
RECORDS, PAGE _____, RECORDED
FOR _____

WEBER COUNTY RECORDER

BY: _____ DEPUTY