

VICINITY MAP Not to Scale

NOTES

- 1. 10' Public Utility and Drainage Easements along the Front Property line and across all of Parcels A-H.
2. Due to the topography and the location of this subdivision all owners will accept responsibility for any storm water runoff from the road adjacent to this property until curb and gutter is installed.
3. Lowest Finished Floor Elevation (LFFE) to be a maximum of 3.0' below Existing Grade or 4.0' below the Top Back of curb at the Lowest corner of the Lot whichever is higher.

BENCHMARK

Brass Cap Section Monument located in the South East Quarter Corner of Section 16, T6N, R2W, SLB&M, U.S. (Found Brass Cap Monument in good condition dated 1963).

Legend: Monument to be set, Found Centerline Monument, Radial Line, Non-Radial Line, Public Utility Easement, Public Utility & Drainage Easement, Fence, Buildable Area, Floodplain, Easement, Buildable area, Bank of Slough, Existing Boundary, Set Hub & Tack, Nail will be set in Curb, Extension of Property, Section Corner.

Riverbend Farms Phase 2

A Cluster Subdivision
A part of Section 15 and Section 16, T6N, R2W, SLB&M, U.S. Survey,
Weber County, Utah
February 2024

NARRATIVE

This Subdivision plot was requested by Edward Gramp for the purpose of creating 47 residential Lots, 1 Agricultural preservation parcel (L) and 2 common Area parcels (I and J).
Basis of Bearings for this Subdivision is N 89°23'10" W between the Reference Monument for the Southeast corner of Section 16 and the reference monument for the South east corner of Section 15.
Complete boundary retracement and exterior boundary details can be found on a Survey filed with Weber County Surveying department as Filing #7052.
Property corners were monumented as depicted on this plot.

ACKNOWLEDGMENT

State of Utah
County of Weber
The foregoing instrument was acknowledged before me this \_\_\_ day of 2024 by Bryan Bayless.
Residing At:
Commission Number:
Commission Expires:
A Notary Public commissioned in Utah
Print Name

BOUNDARY DESCRIPTIONS

A part of the Southeast corner of Section 16 and the Southwest Quarter of Section 15, Township 6 North Range 2 West, Salt Lake Base and Meridian,
Beginning at a point on the Southeast corner of Open Space G, Riverbend Farms Phase 1 said point being 278.36 feet South 89°19'36" East along the Calculated Section Line and 868.69 feet North 0°40'24" East from the Southeast corner of said Section; and running thence South 89°07'36" West 628.47 feet to the Southeast corner of Riverbend Farms Phase 1; thence nine (9) courses along the Eastern Boundary of said Phase 1 as follows: (1) North 12°03'54" East 116.50 feet to a point of non-tangent curvature, (2) Southeasterly along the arc of a 333.00 foot radius curve to the left a distance of 58.14 feet (Central Angle equals 10°00'12" and Long Chord bears South 82°52'58" East 58.07 feet) (3) North 02°06'56" East 66.00 feet; (4) North 09°59'56" East 332.82 feet; (5) North 10°08'45" East 247.85 feet; (6) North 10°09'12" East 242.74 feet; (7) North 07°24'45" East 66.00 feet; (8) North 82°37'58" West 51.23 feet; and (9) North 07°22'02" East 104.62 feet; thence South 81°52'12" East 169.95 feet; thence South 83°35'30" East 443.95 feet to a point on the West boundary line of Open Space G; thence South 09°32'27" West 1091.06 feet along said West Boundary line to the Point of Beginning
Together with:
Beginning at a point on a corner of Open Space G, Riverbend Farms Phase 1 said point being 633.05 feet South 89°19'36" East along the Calculated Section Line and 2037.60 feet North 0°40'24" East from the Southeast corner of said Section; and running thence four (4) courses along the West and North Boundaries of said Parcel G as follows: (1) North 00°43'36" East 10.00 feet; (2) South 89°16'24" East 52.52 feet; (3) North 04°50'20" East 304.09 feet; and (4) North 85°09'40" West 230.87 feet; thence North 04°50'20" East 129.02 feet; thence North 07°17'55" East 251.26 feet; thence North 05°35'21" East 791.88 feet; thence North 88°00'25" East 307.05 feet; thence South 60°01'10" East 624.80 feet; thence South 07°11'21" West 222.70 feet; thence North 85°39'07" West 150.61 feet to a point on a non-tangent curve to the left having a radius of 265.80 feet; thence along said arc a distance of 170.99 feet, Central Angle equals 36°51'31" and Long Chord bears South 72°18'54" West 168.06 feet to a point of non-tangency; thence South 46°24'03" West 184.50 feet; thence South 40°28'27" West 102.35 feet to a point of curvature to the left having a radius of 100.00 feet; thence Southerly along said arc 140.66 feet, Central Angle equals 80°35'22" and Long Chord bears South 00°10'46" West 129.34 feet; thence South 40°06'55" East 107.11 feet; thence South 56°17'58" East 95.63 feet; thence South 56°36'08" East 107.75 feet; thence South 47°45'12" East 14.77 feet; thence South 00°09'34" West 403.63 feet; thence North 89°16'24" West 526.00 feet to the POINT OF BEGINNING.
Containing 34.303 acres, more or less.

Found Reference monument to the Southeast corner of Section 16, T6N, R2W, SLB&M, U.S. Survey (Found Brass Cap Monument in good condition dated 1963)

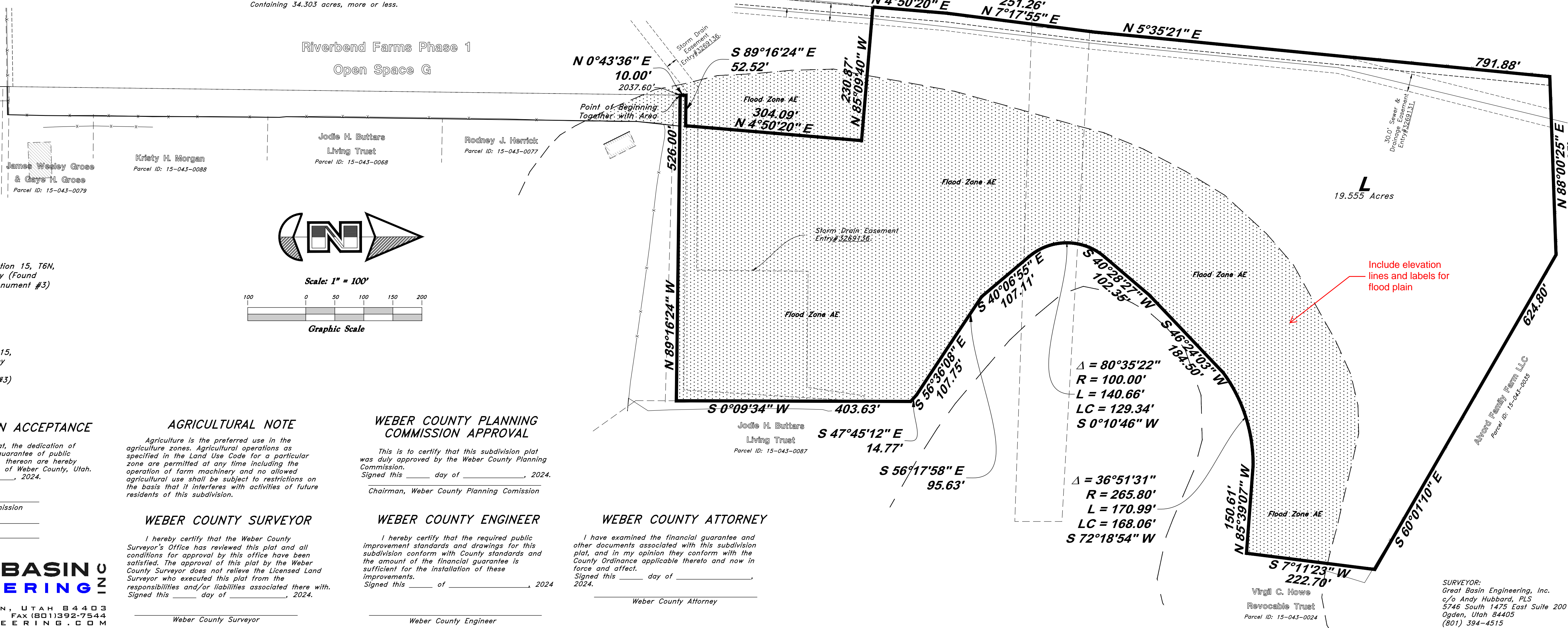
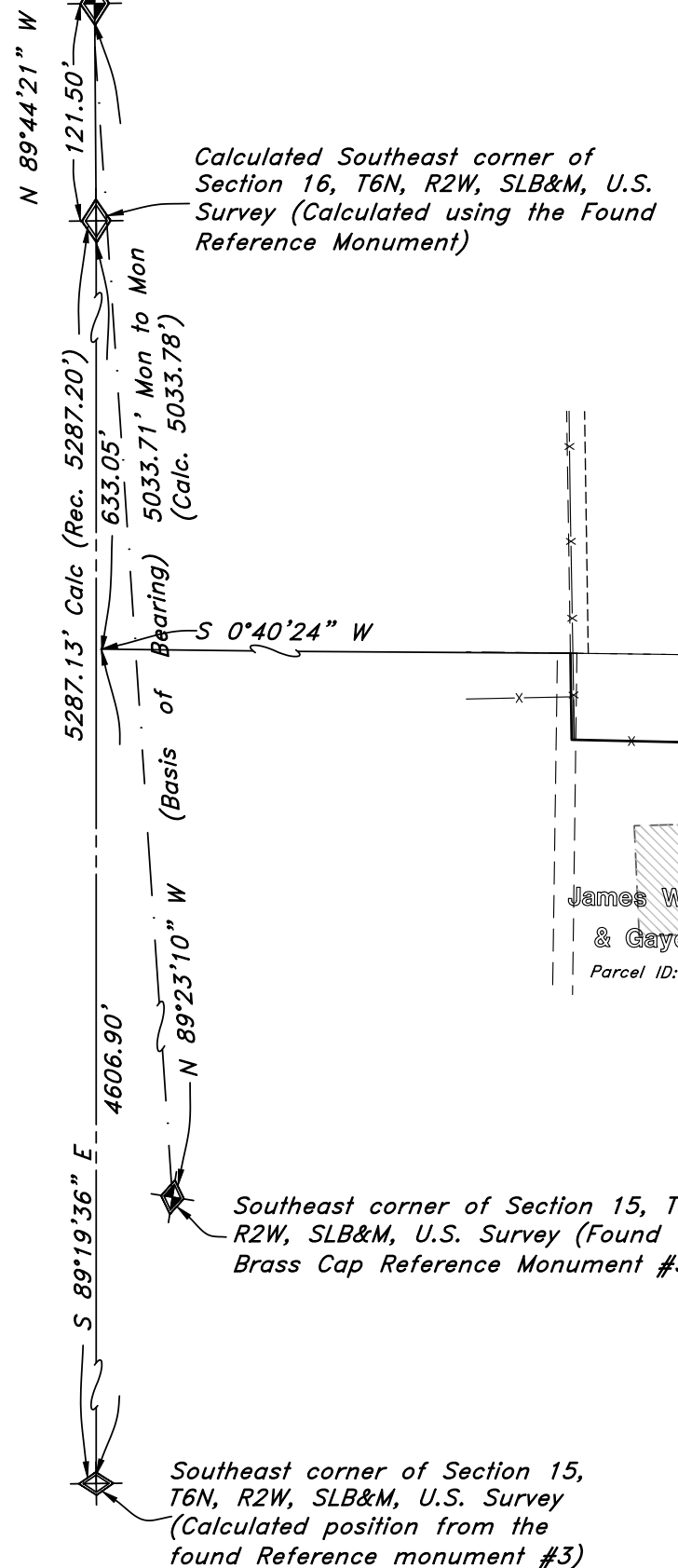

WEBER COUNTY COMMISSION ACCEPTANCE

This is to certify that this subdivision plat, the dedication of streets and other public ways and financial guarantee of public improvements associated with this subdivision, thereon are hereby approved and accepted by the Commissioners of Weber County, Utah. Signed this \_\_\_ day of \_\_\_, 2024.

AGRICULTURAL NOTE

Agriculture is the preferred use in the agriculture zones. Agricultural operations as specified in the Land Use Code for a particular zone are permitted at any time including the operation of farm machinery and no allowed agricultural use shall be subject to restrictions on the basis that it interferes with activities of future residents of this subdivision.

WEBER COUNTY PLANNING COMMISSION APPROVAL

This is to certify that this subdivision plat was duly approved by the Weber County Planning Commission. Signed this \_\_\_ day of \_\_\_, 2024.

WEBER COUNTY SURVEYOR

I hereby certify that the Weber County Surveyor's Office has reviewed this plat and all conditions for approval by this office have been satisfied. The approval of this plat by the Weber County Surveyor does not relieve the Licensed Land Surveyor who executed this plat from the responsibilities and/or liabilities associated therewith. Signed this \_\_\_ day of \_\_\_, 2024.

WEBER COUNTY ENGINEER

I hereby certify that the required public improvement standards and drawings for this subdivision conform with County standards and the amount of the financial guarantee is sufficient for the installation of these improvements. Signed this \_\_\_ of \_\_\_, 2024.

WEBER COUNTY ATTORNEY

I have examined the financial guarantee and other documents associated with this subdivision plat, and in my opinion they conform with the County Ordinance applicable thereto and now in force and effect. Signed this \_\_\_ day of \_\_\_, 2024.

GREAT BASIN ENGINEERING logo and address: 5746 SOUTH 1475 EAST OGDEN, UTAH 84403

Webster County Surveyor, Webster County Engineer, Webster County Attorney

SURVEYOR'S CERTIFICATE
I, Andy Hubbard, do hereby certify that I am a Professional Land Surveyor in the State of Utah, and that I hold License No. 6242920 in accordance with Title 58, Chapter 22, of the Professional Engineers and Professional Land Surveyors Licensing Act. I also certify that I have completed a survey of the property described herein in accordance with Section 17-23-17 and that I have verified all measurements shown hereon this plat of Riverbend Farms Phase 2 in Weber County, Utah and that it has been correctly drawn to the designated scale and is a true and correct representation of the following description of lands included in said subdivision, based on data compiled from records in the Weber County Recorder's Office. Monuments have been found or placed as represented on this plat. I furthermore certify that all lots within this Subdivision hereby meet all current lot width and area requirements of the Weber County Zoning Ordinance.

Signed this \_\_\_ day of \_\_\_, 2024

6242920 License No. Andy Hubbard

OWNERS DEDICATION

We the undersigned owners of the herein described tract of land, do hereby set apart and subdivide the same into lots and streets as shown on the plat and name said tract Riverbend Farms Phase 2 Subdivision, and do hereby dedicate and grant to Weber County a perpetual right and easement on and over the agriculture preservation parcel L, to guarantee to Weber County that the agriculture preservation parcels remain open and undeveloped except for approved agricultural, recreational, Secondary Water and storm water purposes except to be used and maintained by the owner of said parcel(s) for approved agricultural purposes, and Secondary Water purposes, and also do grant and dedicate a perpetual right and easement over, upon and under the lands designated hereon as Common Open Space and/or public utility easements, the same to be used for the maintenance and operation of Sanitary Sewer lines and Structures, Storm Drainage Lines and Structures and/or public utility service lines and storm drainage facilities, whichever is applicable as may be authorized by the governing authority, we also dedicate and grant to Weber County, all those parts or portions of said tract designated as Trail Easement, the same to be used as a public trail for pedestrian ingress and egress as may be authorized by the governing authority.
We also do hereby dedicate, grant and convey to the Owners Association the Parcels referred to as Common Open Spaces parcels I, through J, and also dedicate and grant a perpetual right and easement over, upon and under the lands designated hereon as Open Spaces I though J and Agricultural Parcel L for Secondary Water Facilities, Storm Water Detention, Agricultural uses and purposes. The same to be used for the maintenance and operation of storm drainage facilities, Secondary Water facilities as applicable as may be authorized by the governing authority, with no residential buildings or structures being erected within such parcels as shown hereon which is defined in the Covenants, Conditions, and Restrictions (CC&R's) for this development, and additionally dedicate and convey to Weber County a perpetual open space easement on, under, and over all parcels and areas denoted as open space parcels or areas to guarantee to the public that those parcels and areas remain open and undeveloped in a manner consistent with the approved open space plan.
We also grant and dedicate a perpetual right and easement over, upon and under the lands designated hereof as public utility service lines, storm drainage facilities, irrigation canals or for the perpetual preservation of water channels in their natural state whichever is applicable as may be authorized by the governing authority, with no buildings or structures being erected within such easements; and further dedicate to public use all those parts or portions of said tract of land designated as streets, the same to be used as public thoroughfares.

Signed this \_\_\_ Day of \_\_\_, 2024.

Riverbend Holdings, LLC

Bryan Bayless 5817 South 1475 East, SOUTH OGDEN UT 84403

WEBER COUNTY RECORDER
ENTRY NO. FILED FOR RECORD AND RECORDED AT IN BOOK OF OFFICIAL RECORDS, PAGE RECORDED FOR
WEBER COUNTY RECORDER
BY: DEPUTY

Curve #	Delta	Radius	Length	Chord Direction	Chord Length
C1	10°00'12"	333.00'	58.14'	S 82°52'58" E	58.07'
C2	2°59'20"	333.00'	17.37'	S 89°22'44" E	17.37'
C3	96°19'02"	10.50'	17.65'	S 42°42'53" E	15.64'
C4	7°13'09"	407.85'	51.39'	S 2°17'07" W	51.35'
C5	9°03'07"	400.00'	63.19'	N 3°39'09" E	63.13'
C6	1°20'58"	400.00'	9.42'	N 8°51'12" E	9.42'
C7	84°40'38"	10.50'	15.52'	N 54°32'04" E	14.14'
C8	84°39'14"	10.50'	15.51'	N 35°27'56" W	14.14'
C9	87°50'21"	10.50'	16.10'	S 53°26'51" W	14.57'
C10	92°29'36"	10.50'	16.95'	S 36°23'10" E	15.17'
C11	4°43'09"	230.00'	18.94'	S 7°30'03" W	18.94'
C12	6°00'52"	230.00'	24.14'	S 2°08'02" W	24.13'
C13	90°00'00"	10.50'	16.49'	S 44°07'36" W	14.85'
C14	2°59'20"	267.00'	13.93'	N 89°22'44" W	13.93'
C15	90°00'00"	10.50'	16.49'	N 45°52'24" W	14.85'
C16	79°35'55"	10.50'	14.59'	S 49°19'38" W	13.44'
C17	92°09'39"	10.50'	16.89'	S 36°33'09" E	15.13'
C18	87°30'24"	10.50'	16.04'	N 53°36'50" E	14.52'
C19	10°44'02"	170.00'	31.85'	N 4°29'37" E	31.80'

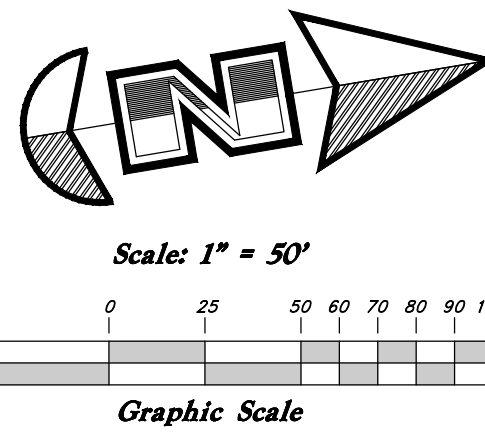

# Riverbend Farms Phase 2

A Cluster Subdivision  
 A part of Section 15 and Section 16, T6N, R2W, SLB&M, U.S. Survey,  
 Weber County, Utah  
 February 2024

- Legend**
- ⊕ Monument to be set
  - ⊕ Found Centerline Monument
  - (Rad.) Radial Line
  - (N/R) Non-Radial Line
  - PUE Public Utility Easement
  - PU&DE Public Utility & Drainage Easement
  - - - - - Fence
  - Buildable Area
  - Floodplain
  - Easement
  - Buildable area
  - Bank of Slough
  - Existing Boundary
  - ⊙ Set Hub & Tack
  - ⊙ A Nail will be set in Curb
  - ⊙ Extension of Property
  - ⊙ Set 5/8" x 24" Long Rebar & Cap w/ Lathe
  - ⊙ Section Corner



Kent A. Hansen & Kathryn A. Hansen  
 Parcel ID: 15-045-0060

Scott M. Neeley & Kristen Kay Neeley  
 Revocable Trust  
 Parcel ID: 15-203-0002

**GREAT BASIN ENGINEERING**  
 5746 SOUTH 1475 EAST OGDEN, UTAH 84403  
 MAIN (801)394-4515 S.L.C. (801)521-0222 FAX (801)392-7544  
 WWW.GREATBASINENGINEERING.COM

SURVEYOR:  
 Great Basin Engineering, Inc.  
 c/o Andy Hubbard, PLS  
 5746 South 1475 East Suite 200  
 Ogden, Utah 84405  
 (801) 394-4515

Sheet 1 of 2

WEBER COUNTY RECORDER

ENTRY NO. \_\_\_\_\_ FILED \_\_\_\_\_ FEE PAID \_\_\_\_\_

RECORDED \_\_\_\_\_ AT \_\_\_\_\_

IN BOOK \_\_\_\_\_ OF OFFICIAL RECORDS, PAGE \_\_\_\_\_, RECORDED FOR \_\_\_\_\_

WEBER COUNTY RECORDER

BY: \_\_\_\_\_ DEPUTY

# Riverbend Farm Phase 2

A part of the Southeast Quarter of Section 16 and the West Half of Section 15,  
T6N, R2W, SLB&M, U.S. Survey, Weber County, Utah  
February 2024



VICINITY MAP  
(Not to Scale)

\* See All Sheets\*

**NOTES**

- All construction shall conform to Weber County standards and specifications.
- Culinary water services will be 1" Dia. Poly Pipe (200 P.S.I. CTS Poly Pipe AWWA Standard C901) to be centered on the frontage and extended 10' beyond the right of way line.
- 4" Sanitary sewer laterals to be constructed 10' down slope from the center of the lot and extended 10' beyond the right of way line.
- 4" Land drain laterals to be constructed at the low corner of the lot and extended 10' beyond the right of way line.
- See ~~CUT~~ Existing Asphalt to provide a smooth clean edge.
- All utility trenches within the Street right of way shall have a City approved imported granular backfill.
- Thrust block all water line fittings.
- All inlet grates shall be bicycle safe.
- All fire hydrants and access roads shall be installed prior to any construction of any buildings.
- All fire hydrants shall be placed with 4 1/2 inch connections facing the point of access for the Fire Department Apparatus.
- Prior to the beginning of construction of any buildings, a fire flow test of new hydrants shall be conducted to verify the actual fire flow for this project. The Fire Prevention Division shall witness this test and shall be notified a minimum of 48 hours prior to the test.
- Curb & gutter installed along 3600 West Street will be set to ensure a 1.5% minimum/3.0% Maximum cross slope from edge of asphalt. Contractor to verify prior to construction of curb.
- An excavation permit is required for all work done within the existing Right of Way.
- A Storm Water Construction Activity Permit is required for any construction that disturbs more than 5000 Sq. Ft. or 200 Cubic Yards.
- All improvements need to be either installed or escrowed prior to recording of the subdivision.
- If construction activity will disturb more than an acre then a State SWPPP will be required. This includes the construction of the homes etc. on each lot.

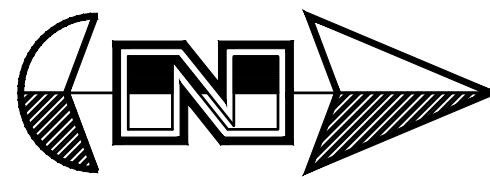

- NOT TO SCALE -

delete if not part of actual plans

not applicable to this phase

**GENERAL UTILITY NOTES:**

- Coordinate all utility connections to building with plumbing plans and building contractor.
- Verify depth and location of all existing utilities prior to constructing any new utility lines. Notify Civil Engineer of any discrepancies or conflicts prior to any connections being made.
- All catch basin and inlet box grates are to be bicycle proof.
- All inlet boxes located in curb and gutter are to be placed parallel to the curb and gutter and set under the frame and grate. Improperly placed boxes will be removed and replaced at no additional cost to the owner. Precast or cast in place boxes are acceptable.
- Refer to the site electrical plan for details and locations of electrical lines, transformers and light poles.
- Gas lines, telephone lines, and cable TV lines are not a part of these plans unless otherwise noted.
- Water meters are to be installed per city standards and specifications. It will be the contractor's responsibility to install all items required.
- Water lines, valves, fire hydrants, fittings etc. are to be constructed as shown. Contractor is responsible to construct any vertical adjustments necessary to clear sewer, storm drain or other utilities as necessary including valve boxes and hydrant spools to proper grade.
- Field verify all existing and/or proposed Roof Drain/Roof Drain down spout connections to Storm Water System with Civil, Plumbing & Architectural plans. Notify Engineer of any discrepancies.
- All gravity flow utility lines shall be installed prior to any pressurized utilities unless written permission is obtained from the engineer of record before construction begins.

**UTILITY PIPING MATERIALS:**

All piping to be installed per manufacturers recommendations. Refer to project specifications for more detailed information regarding materials, installation, etc.

**CULINARY SERVICE LATERALS**

- 3/4" to 1" diameter pipe - 200 PSI CTS Poly (AWWA Standard C901)
- Over 2" diameter pipe - AWWA C-900 Class 150 pipe (DR18)

**WATER MAIN LINES AND FIRE LINES**

- Pipe material as shown on utility plan view or to meet city standards.

**SANITARY SEWER LINES**

- All sewer piping to be Polyvinyl Chloride (PVC) sewer pipe, ASTM D 3034, Type PSM, SDR 35

**STORM DRAIN LINES**

- 10" pipes or smaller - Polyvinyl Chloride (PVC) sewer pipe, ASTM D3034, Type PSM, SDR 35
- 12" to 21" pipes - Concrete Pipe, ASTM C14, Class III up to 13' of cover. For greater than 13' feet of cover, use reinforced concrete pipe and classes listed below.
- 24" pipes or larger - Reinforced Concrete Pipe, ASTM C76, Class III up to 13' of cover, Class IV for 13' to 21' of cover, Class V for 21' to 32' of cover, and Special Design for cover greater than 32 feet.

**CAUTION NOTICE TO CONTRACTOR**  
The contractor is specifically cautioned that the location and/or elevation of existing utilities as shown on these plans are based on records of the various utility companies and, where possible, measurements taken in the field. The information is not to be relied on as being exact or complete. The contractor must call the appropriate utility company at least 48 hours before any excavation to request exact field location of utilities. It shall be the responsibility of the contractor to relocate all existing utilities which conflict with the propose improvements shown on the plans.

**PRIVATE ENGINEER'S NOTICE TO CONTRACTORS**  
The Contractor agrees that he shall assume sole and complete responsibility for job site conditions during the course of construction of this project, including safety of all persons and property; that this requirement shall apply continuously and not be limited to normal working hours; and that the contractor shall defend, indemnify, and hold the owner and the engineer harmless from any and all liability, real or alleged, in connection with the performance of work on this project, excepting for liability arising from the sole negligence of the owner or the engineer.

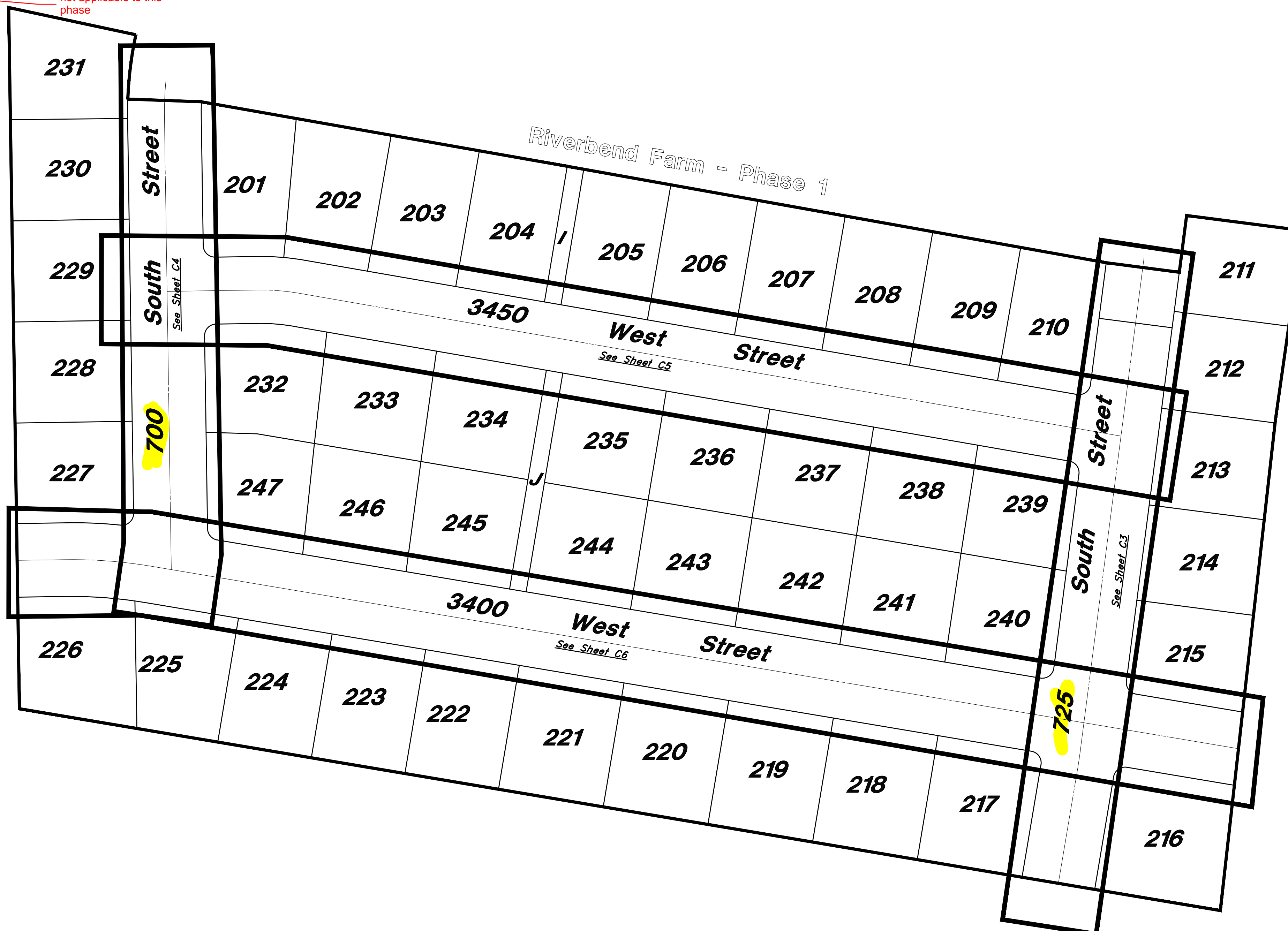

**Legend**

(Note: All items may not appear on drawing)

- San. Sewer Manhole
  - Water Manhole
  - Storm Drain Manhole
  - Cleanout
  - Electrical Manhole
  - Catch Basins
  - Exist. Fire Hydrant
  - Exist. Water Valve
  - Water Valve
  - Sanitary Sewer
  - Culinary Water
  - Gas Line
  - Irrigation Line
  - Storm Drain
  - Telephone Line
  - Secondary Waterline
  - Power Line
  - Fire Line
  - Land Drain
  - Power pole
  - Power pole w/guy
  - Light Pole
  - Fence
  - Flowline of ditch
  - Overhead Power line
  - Corrugated Metal Pipe
  - Concrete Pipe
  - Reinforced Concrete Pipe
  - Ductile Iron
  - PVC
  - TA
  - E4
  - CL
  - Flowline
  - FL
  - Top of Curb
  - Top of Wall
  - Top of Walk
  - TCN
  - Natural Ground
  - FG
  - Finish Grade
  - ME
  - Fire Department Connection
  - FDG
  - Finish Contour
  - 90
  - Exist. Contour
  - 90
  - Finish Grade
  - 95.727A
  - Exist. Grade
  - 95.727A
  - Ridge Line
  - R
  - Direction of Flow
- Existing Asphalt
- New Asphalt
- Existing Concrete
- New Concrete

- Sheet List:**
- C0 - Cover
  - C1 - Grading
  - C2 - Utility
  - C3 - 725 South Street
  - C4 - 700 South Street
  - C5 - 3450 West Street
  - C6 - 3400 West Street
  - C7 - Details
  - C8 - Details

REV	DATE	DESCRIPTION

**GREAT BASIN ENGINEERING**  
 5746 SOUTH 1475 EAST OGDEN, UTAH 84403  
 MAIN (801)394-4515 SLLC (801)521-0222 FAX (801)392-7544  
 WWW.GREATBASINENGINEERING.COM

**Cover**  
**Riverbend Farm Phase 2**  
 A part of the Southeast Quarter of Section 16 and the West Half of Section 15, T6N, R2W, SLB&M, Weber County, Utah

February 2024  
SHEET NO.  
**CO**  
21N724 - BP

NOT FOR CONSTRUCTION



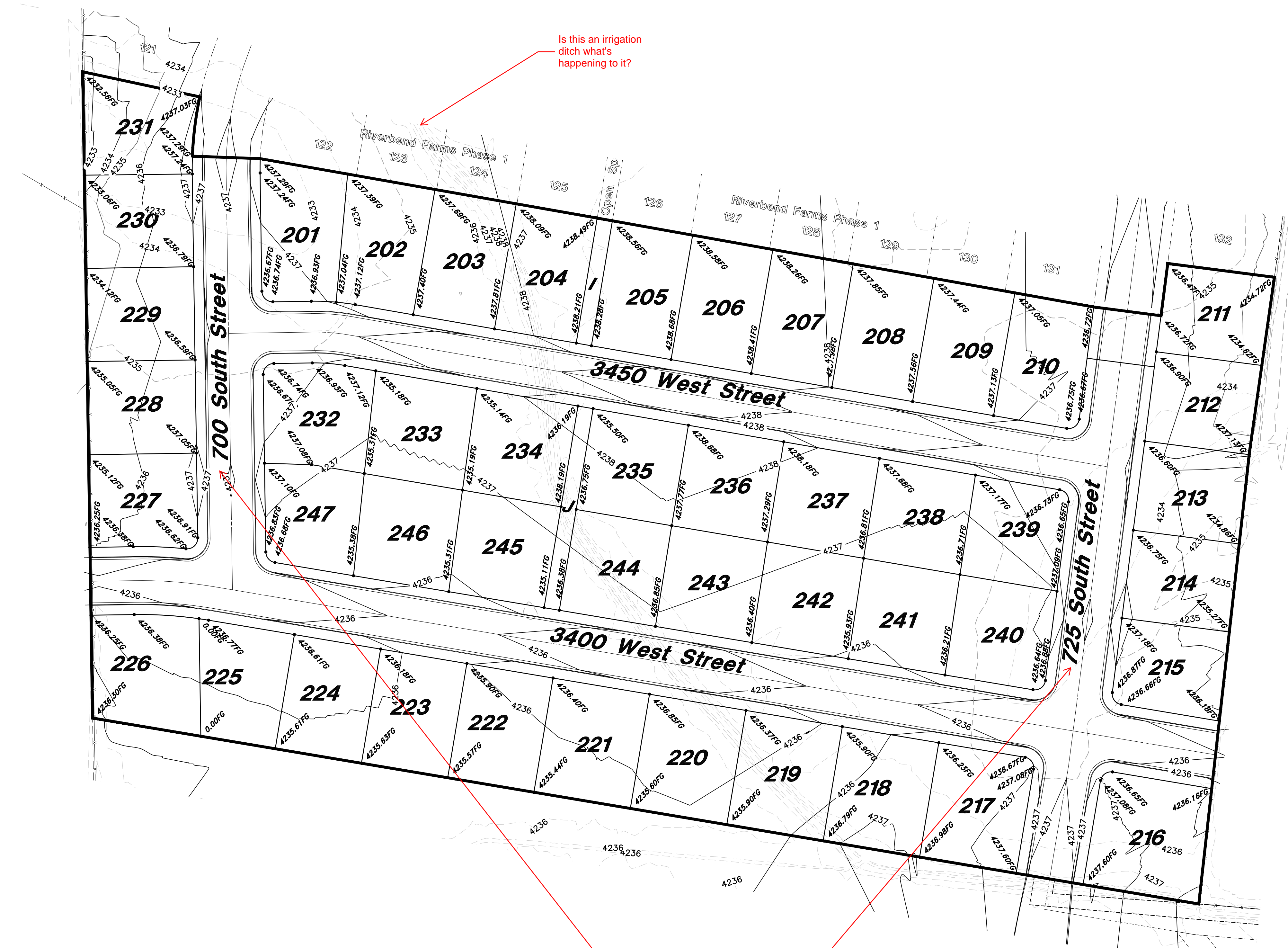
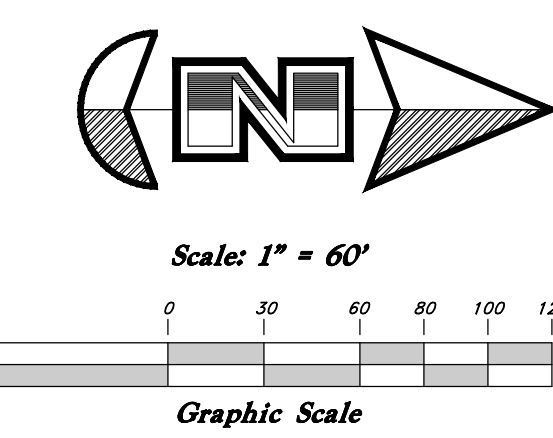

**GENERAL GRADING NOTES:**

- All work shall be in accordance with the City Public Works Standard. *check with geotech report*
- Cut slopes shall be no steeper than 2 horizontal to 1 vertical.
- Fill slopes shall be no steeper than 2 horizontal to 1 vertical.
- Fills shall be compacted per the recommendations of the geotechnical report prepared for the project and shall be certified by the geotechnical engineer.
- Areas to receive fill shall be properly prepared and approved by the City Inspector and geotechnical Engineer prior to placing fill.
- Fills shall be benched into competent material as per specifications and geotechnical report.
- All trench backfill shall be tested and certified by the site geotechnical engineer per the grading code.
- A geotechnical engineer shall perform periodic inspections and submit a complete report and map upon completion of the rough grading.
- The final compaction report and certification from the geotechnical engineer shall contain the type of field testing performed. Each test shall be identified with the method of obtaining the in-place density, whether sand cone or drive ring and shall be so noted for each test. Sufficient maximum density determinations shall be performed to verify the accuracy of the maximum density curves used by the field technician.
- Dust shall be controlled by watering.
- The location and protection of all utilities is the responsibility of the permittee.
- Approved protective measures and temporary drainage provisions must be used to protect adjoining properties during the grading project.
- All public roadways must be cleared daily of all dirt, mud and debris deposited on them as a result of the grading operation. Cleaning is to be done to the satisfaction of the city engineer.
- The site shall be cleared and grubbed of all vegetation and deleterious matter prior to grading.
- The contractor shall provide shoring in accordance with OSHA requirements for trench walls.
- Aggregate base shall be compacted per the geotechnical report prepared for the project.
- Elevations shown on this plan are finish grades. Rough grades are the subgrades of the improvements shown hereon.
- The recommendations in the following Geotechnical Engineering Report by Gordon Geotechnical Engineering, Inc. are included in the requirements of grading and site preparation.  
The report is titled "GEOTECHNICAL STUDY, PROPOSED WHEATRIDGE TOWNHOMES"  
Job No.: 877-001-20 Address: Approximately 3125 North 1700 East  
Layton, UT  
Dated: October 25, 2020
- As part of the construction documents, owner that provided contractor with a topographic survey performed by manual or aerial means. Such survey was prepared for project design purposes and is provided to the contractor as a courtesy. It is expressly understood that such survey may not accurately reflect existing topographic conditions.
- Erosion Control: Protect all inlet boxes, catch basins, etc. with straw bales or other approved method to strain the storm water during construction. Protect surrounding properties and streets from site runoff with sandbags and earth berms.

**CURB AND GUTTER CONSTRUCTION NOTES:**

- It is the responsibility of the surveyor to adjust top of curb grades at the time construction staking.
- Refer to the typical details for a standard and open face curb and gutter for dimensions.
- Transitions between open face and standard curb and gutter are to be smooth. Hand form these areas if necessary.

**ADA NOTES:**

Contractor must maintain a running slope on Accessible routes no steeper than 5.0% (1:20). The cross slope for Accessible routes must be no steeper than 2.0% (1:50). All Accessible routes must have a minimum clear width of 36". If grades on plans do not meet this requirement notify Consultants immediately.

The Client, Contractor, and Subcontractor should immediately notify the Consultant of any conditions of the project that they believe do not comply with the current state of the ADA and/or FHAA.

**PRIVATE ENGINEER'S NOTICE TO CONTRACTORS**

The Contractor agrees that he shall assume sole and complete responsibility for job site conditions during the course of construction of this project, including safety of all persons and property; that this requirement shall apply continuously and not be limited to normal working hours; and that the contractor shall defend, indemnify, and hold the owner and the engineer harmless from any and all liability, real or alleged, in connection with the performance of work on this project, excepting for liability arising from the sole negligence of the owner or the engineer.

ALL CONSTRUCTION TO CONFORM TO CITY STANDARDS AND SPECIFICATIONS IN RIGHT OF WAY

*update info for this project*

*Is this an irrigation ditch what's happening to it?*

*these street addresses don't seem correct*

*County and/or District*

REV	DATE	DESCRIPTION

**GREAT BASIN ENGINEERING**

5746 SOUTH 11475 EAST, OGDEN, UTAH 84403  
 MAIN 8013154517 FAX 8013159271504  
 WWW.GREATBASINENGINEERING.COM

**Grading Plan**

**Riverbend Farm Phase 2**

*A part of the Southeast Quarter of Section 16 and the West Half of Section 15, T6N, R2W, S16&M, Weber County, Utah*

February 2024

SHEET NO.

**C1**

21N724 - 8P

NOT FOR CONSTRUCTION

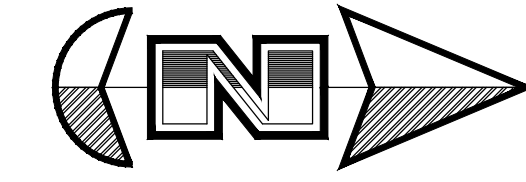

Scale: 1" = 60'

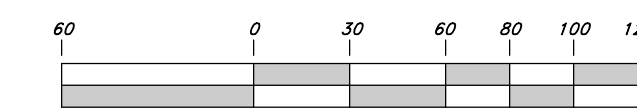

Graphic Scale



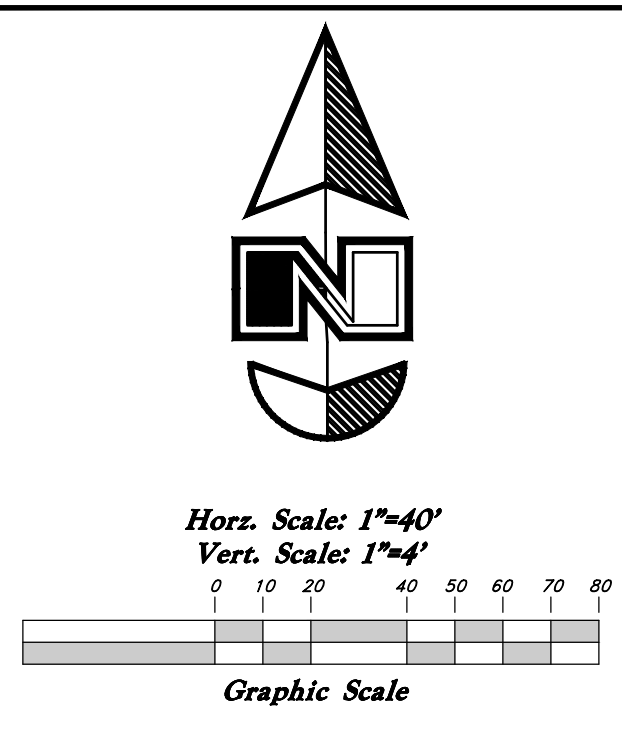

### Legend

- (Note: All items may not appear on drawing)
- San. Sewer Manhole
  - Water Manhole
  - Storm Drain Manhole
  - Electrical Manhole
  - Catch Basins
  - Exist. Fire Hydrant
  - Fire Hydrant
  - Exist. Water Valve
  - Water Valve
  - Sanitary Sewer
  - Culinary Water
  - Gas Line
  - Irrigation Line
  - Storm Drain
  - Telephone Line
  - Secondary Waterline
  - Power Line
  - Fire Line
  - Land Drain
  - Power pole w/guy
  - Light Pole
  - Fence
  - Flowline of ditch
  - Overhead Power line
  - Corrugated Metal Pipe
  - Concrete Pipe
  - Ductile Iron
  - Polyvinyl Chloride
  - Top of Asphalt
  - Edge of Asphalt
  - Centerline
  - Flowline
  - Finish Floor
  - Top of Wall
  - Top of Concrete
  - Natural Ground
  - Finish Contour
  - Exist. Contour
  - Finish Grade
  - Ridge Line
  - Direction of Flow
  - Existing Asphalt
  - New Asphalt
  - Heavy Duty Asphalt
  - Concrete
  - Open Face
  - Curb & Gutter

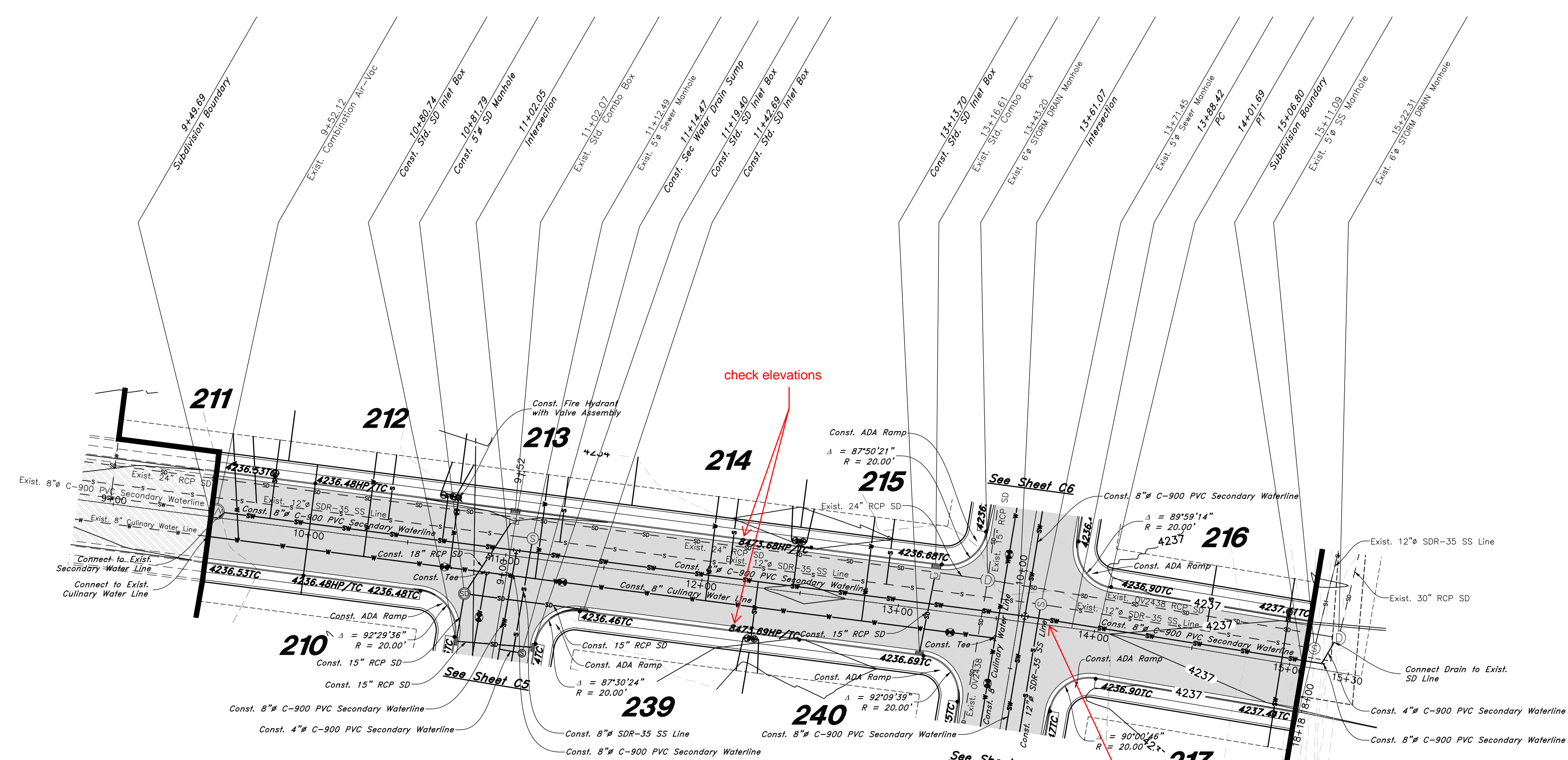

## 725 South Street

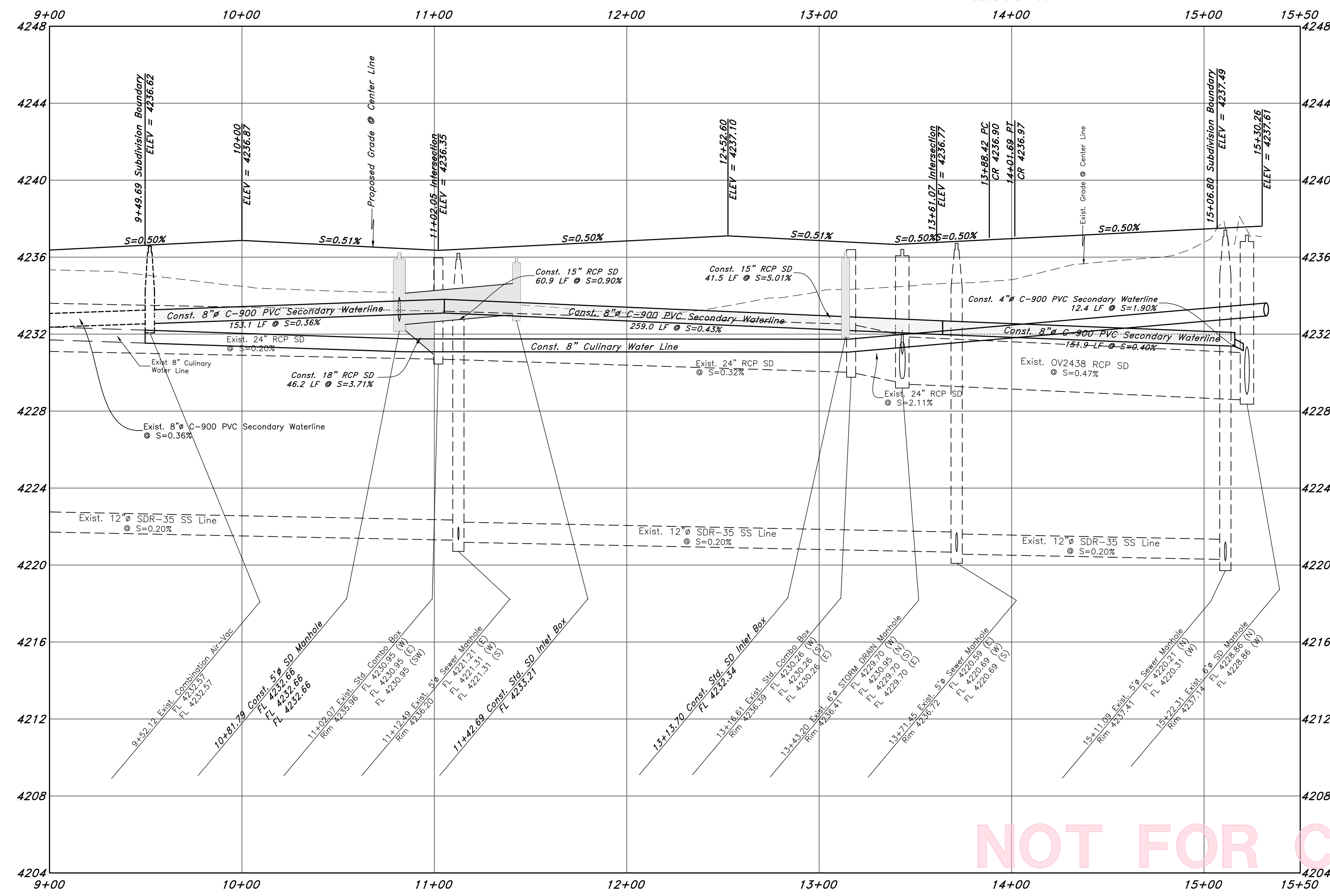

REV	DATE	DESCRIPTION

**GREAT BASIN ENGINEERING**  
 5746 SOUTH 1475 EAST OGDEN, UTAH 84403  
 MAIN (801)394-4515 S.L.L.C. (801)392-7544  
 WWW.GREATBASINENGINEERING.COM

**725 South Street**  
**Riverbend Farm Phase 2**  
 A part of the Southeast Quarter of Section 16 and the West Half of Section 15, T6N, R2W, S16&M, Weber County, Utah

February 2024  
 SHEET NO.  
**C3**  
 21N724 - BP

NOT FOR CONSTRUCTION



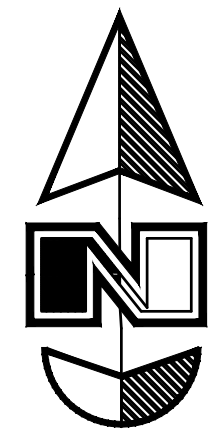

Horz. Scale: 1"=40'

Vert. Scale: 1"=4'



Graphic Scale

### Legend

(Note: All items may not appear on drawing)

- San. Sewer Manhole
- Water Manhole
- Storm Drain Manhole
- Electrical Manhole
- Catch Basins
- Exist. Fire Hydrant
- Fire Hydrant
- Exist. Water Valve
- Water Valve
- Sanitary Sewer
- Culinary Water
- Gas Line
- Irrigation Line
- Storm Drain
- Telephone Line
- Secondary Waterline
- Power Line
- Fire Line
- Land Drain
- Power pole w/guy
- Light Pole
- Fence
- Flowline of ditch
- Overhead Power line
- Corrugated Metal Pipe
- Concrete Pipe
- Reinforced Concrete Pipe
- Ductile Iron
- Polyvinyl Chloride
- Top of Asphalt
- Edge of Asphalt
- Centerline
- Flowline
- Finish Floor
- Top of Wall
- Top of Curb
- Top of Walk
- Top of Concrete
- Natural Ground
- Finish Contour
- Exist. Contour
- Finish Grade
- Exist. Grade
- Ridge Line
- Direction of Flow
- Existing Asphalt
- New Asphalt
- Heavy Duty Asphalt
- Concrete
- Open Face
- Curb & Gutter

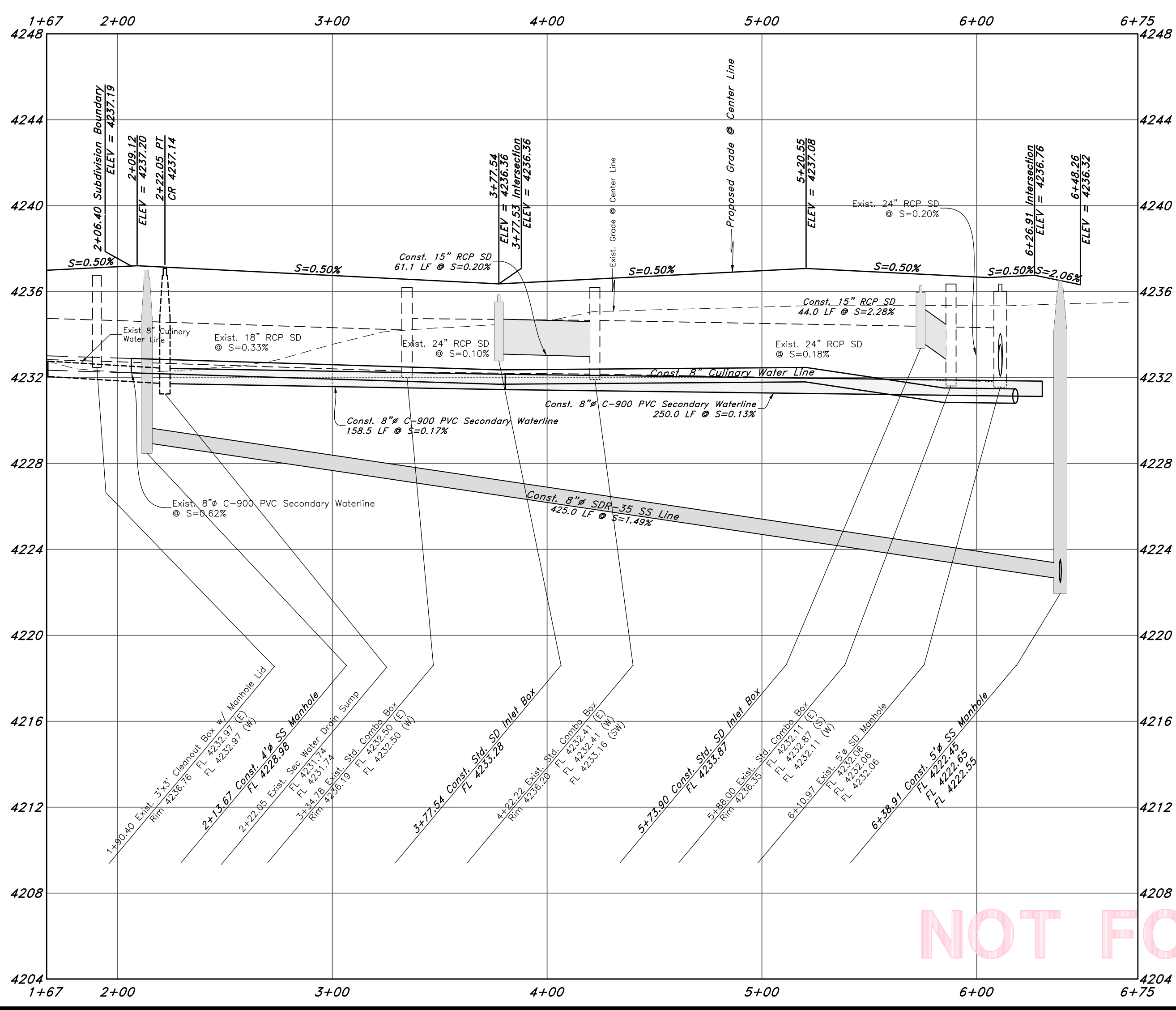
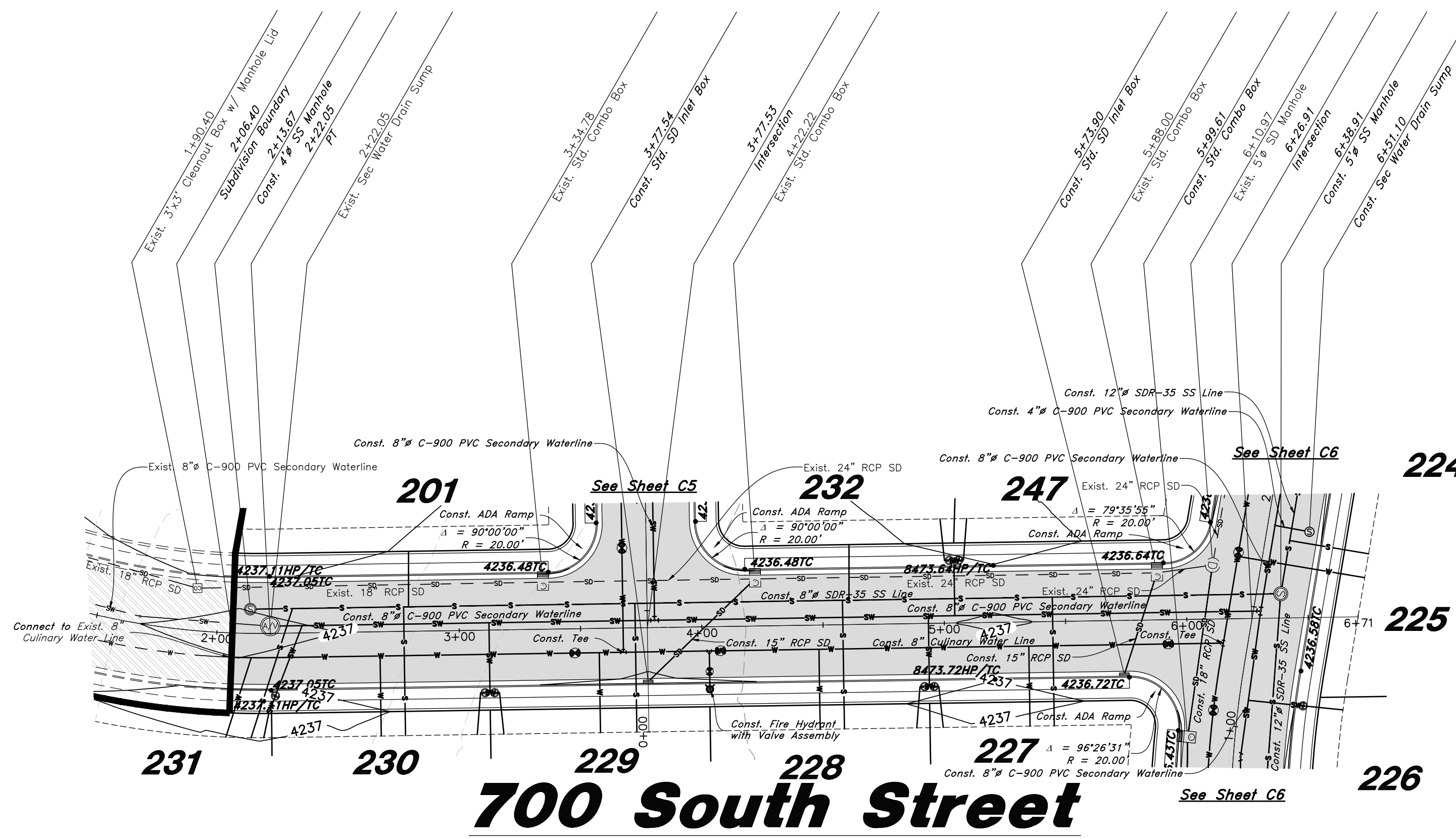

NOT FOR CONSTRUCTION



**GREAT BASIN ENGINEERING**

5746 SOUTH 1475 EAST OGDEN, UTAH 84403  
 MAIN (801)394-4515 S.L.L.C. (801)521-0222  
 WWW.GREATBASINENGINEERING.COM

**700 South Street**

**Riverbend Farm Phase 2**

A part of the Southeast Quarter of Section 16 and the West Half of Section 15, T6N, R2W, S16&M, Weber County, Utah

February 2024

SHEET NO.

**C4**

21N724 - BP

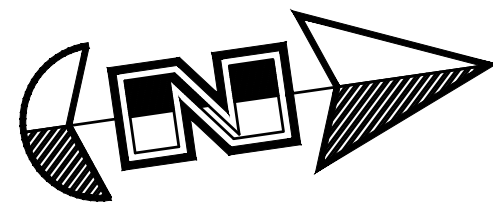

Horz. Scale: 1"=40'  
Vert. Scale: 1"=4'

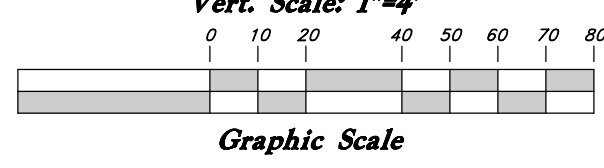

### Legend

(Note: All items may not appear on drawing)

- San. Sewer Manhole
- Water Manhole
- Storm Drain Manhole
- Electrical Manhole
- Catch Basins
- Exist. Fire Hydrant
- Exist. Water Valve
- Water Valve
- Sanitary Sewer
- Culinary Water
- Gas Line
- Irrigation Line
- Storm Drain
- Telephone Line
- Secondary Waterline
- Power Line
- Fire Line
- Land Drain
- Power pole w/guy
- Light Pole
- Fence
- Flowline of ditch
- Overhead Power line
- Corrugated Metal Pipe
- Concrete Pipe
- Reinforced Concrete Pipe
- Ductile Iron
- Polyvinyl Chloride
- Top of Asphalt
- Edge of Asphalt
- Centerline
- Flowline
- Finish Floor
- Top of Curb
- Top of Wall
- Top of Walk
- Top of Concrete
- Natural Ground
- Finish Contour
- Exist. Contour
- Finish Grade
- Exist. Grade
- Ridge Line
- Direction of Flow
- Existing Asphalt
- New Asphalt
- Heavy Duty Asphalt
- Concrete
- Open Face
- Curb & Gutter

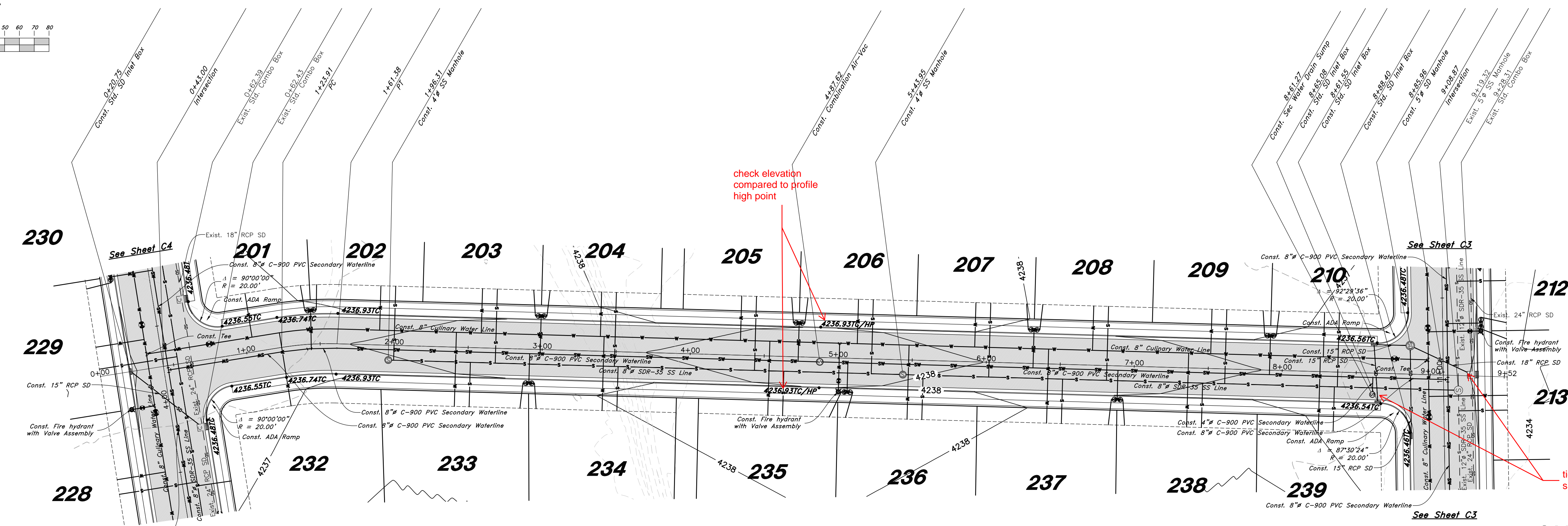

## 3450 West Street

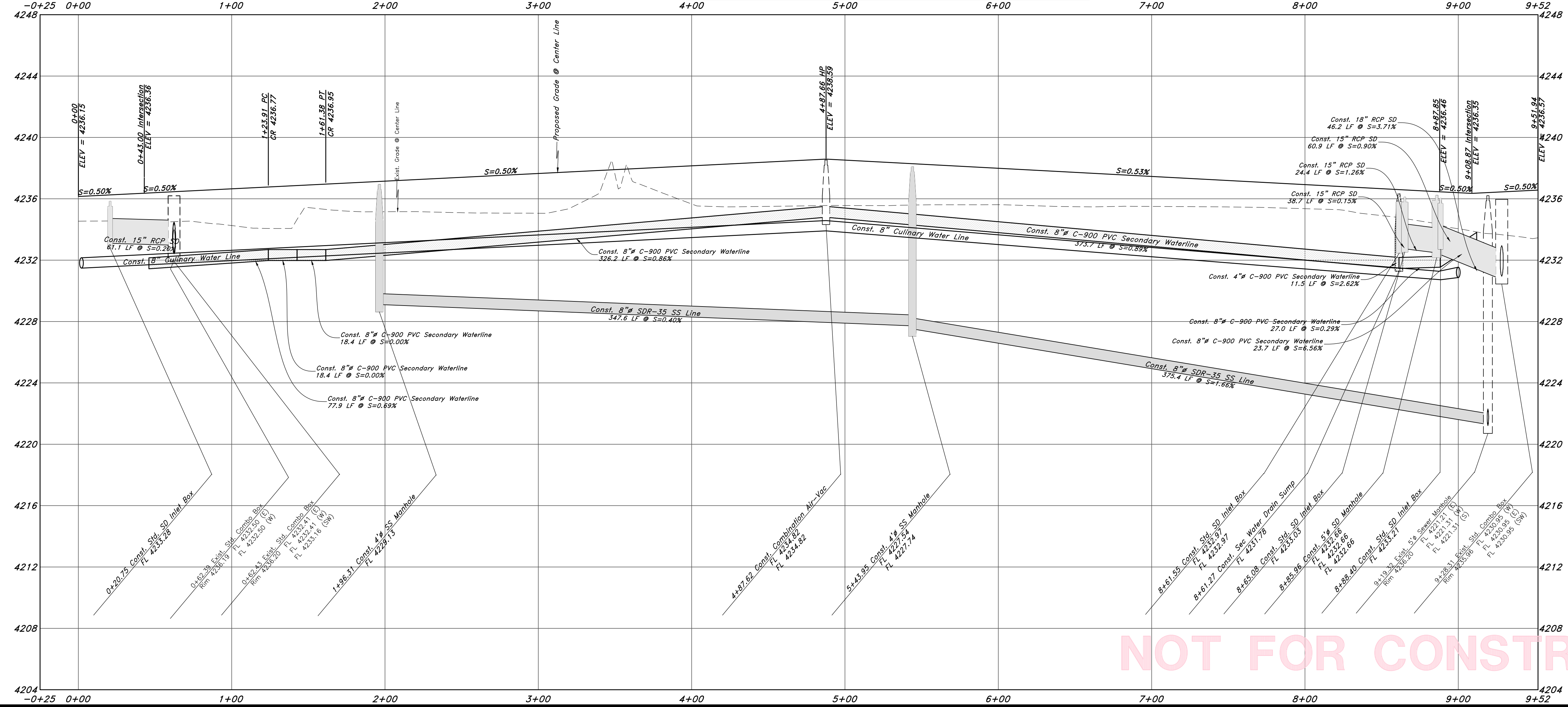

NOT FOR CONSTRUCTION

**GREAT BASIN ENGINEERING**

5746 SOUTH 1475 EAST OGDEN, UTAH 84403  
 MAIN (801)394-4515 S.L.L.C. (801)392-7544  
 WWW.GREATBASINENGINEERING.COM

**3450 West Street**

**Riverbend Farm Phase 2**

A part of the Southeast Quarter of Section 16 and the West Half of Section 15, T6N, R2W, S16&M, Weber County, Utah

February 2024

SHEET NO.

**C5**

21N724 - BP





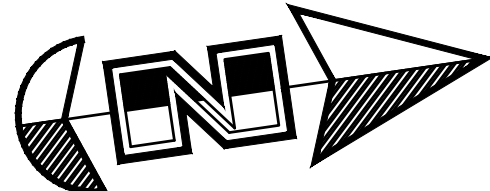

Horz. Scale: 1"=40'  
Vert. Scale: 1"=4'

Graphic Scale

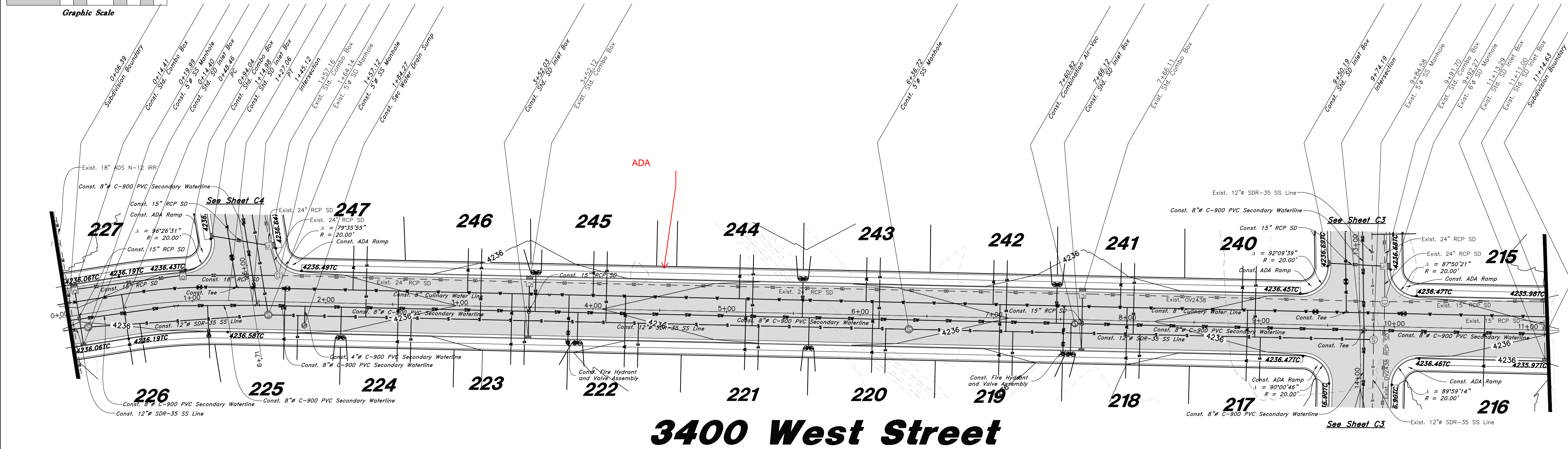
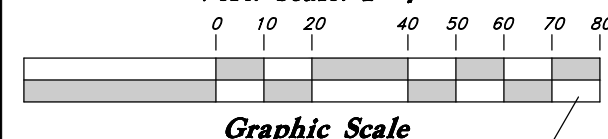

### Legend

(Note: All items may not appear on drawing)

- San. Sewer Manhole
- Water Manhole
- Storm Drain Manhole
- Electrical Manhole
- Catch Basins
- Exist. Fire Hydrant
- Exist. Water Valve
- Water Valve
- Sanitary Sewer
- Culinary Water
- Gas Line
- Irrigation Line
- Storm Drain
- Telephone Line
- Secondary Waterline
- Power Line
- Fire Line
- Land Drain
- Power pole w/guy
- Light Pole
- Fence
- Flowline of ditch
- Overhead Power line
- Corrugated Metal Pipe
- Concrete Pipe
- Reinforced Concrete Pipe
- Ductile Iron
- Polyvinyl Chloride
- Top of Asphalt
- Edge of Asphalt
- Centerline
- Flowline
- Finish Floor
- Top of Curb
- Top of Wall
- Top of Work
- Exist. Contour
- Natural Ground
- Finish Contour
- Finish Grade
- Exist. Grade
- Ridge Line
- Direction of Flow
- Existing Asphalt
- New Asphalt
- Heavy Duty Asphalt
- Concrete
- Open Face
- Curb & Gutter

## 3400 West Street

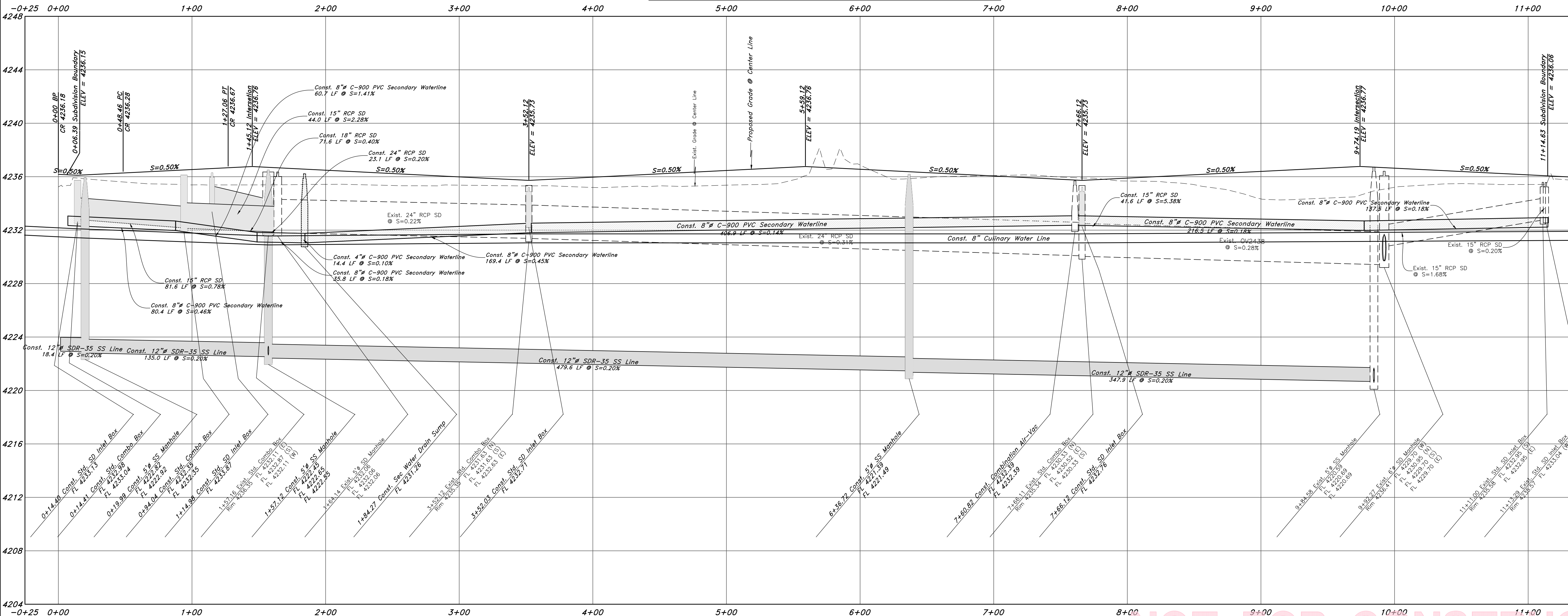

REV	DATE	DESCRIPTION

**GREAT BASIN ENGINEERING**

5746 SOUTH 1475 EAST OGDEN, UTAH 84403  
 MAIN (801)394-4451 S.L.L.C. (801)521-0222 FAX (801)392-7544  
 WWW.GREATBASINENGINEERING.COM

**3400 West Street**

**Riverbend Farm Phase 2**

A part of the Southeast Quarter of Section 16 and the West Half of Section 15, T6N, R2W, S16&M, Weber County, Utah

February 2024

SHEET NO.

**C6**

21N724 - BP

NOT FOR CONSTRUCTION



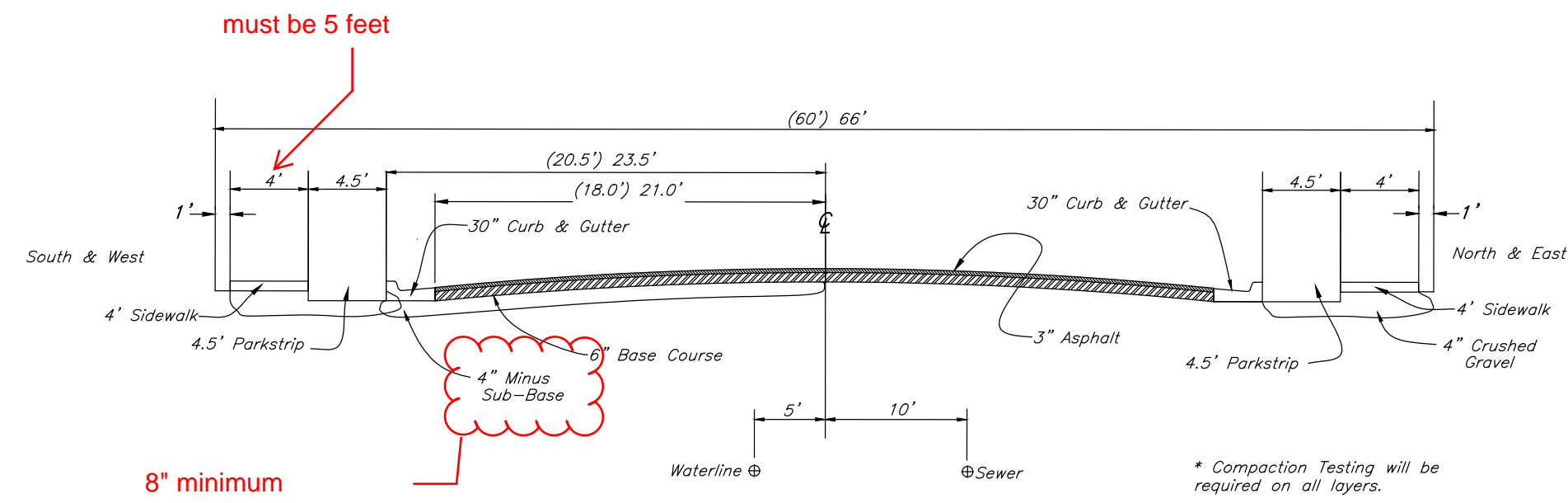

**1 Standard Roadway Section**  
NOT TO SCALE

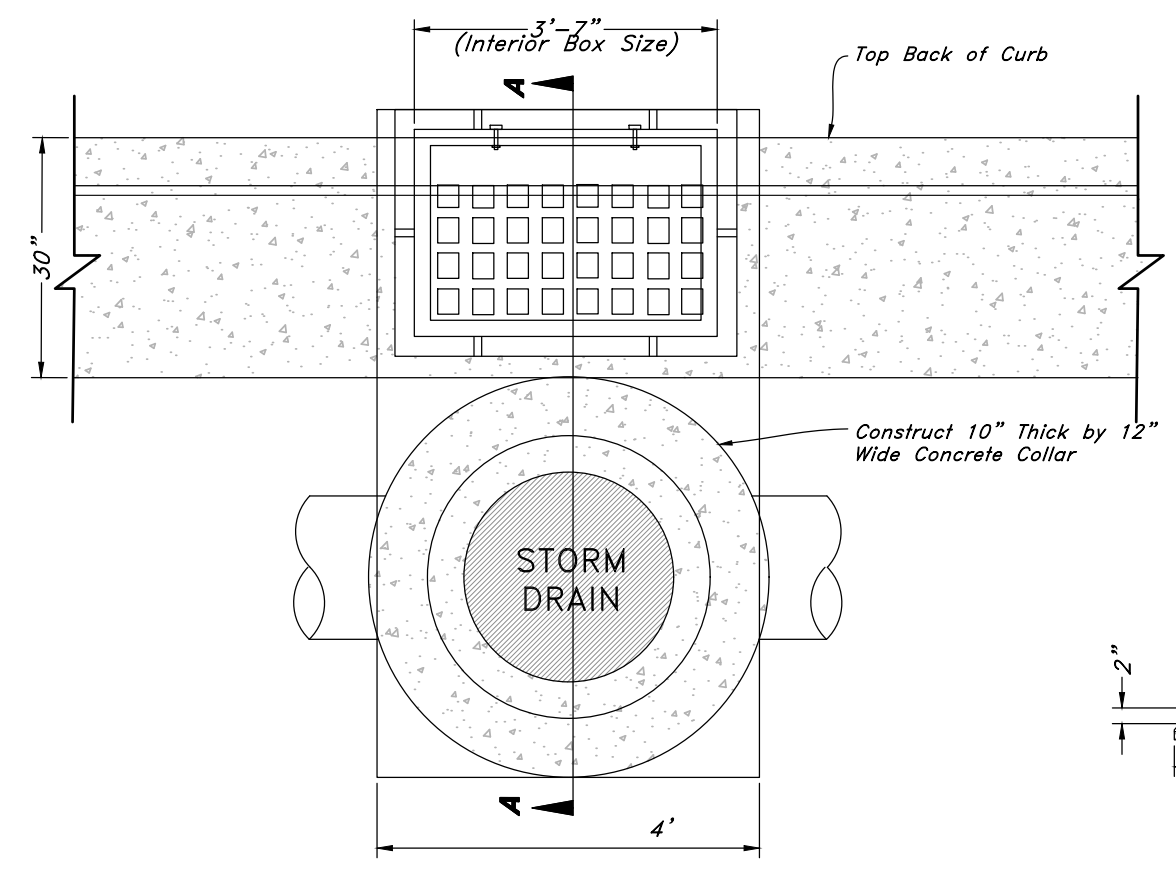

**Inlet Frame & Grate with Adjustable Curb Box**  
(Olympic Foundry I-3517 or Acceptable Equal)

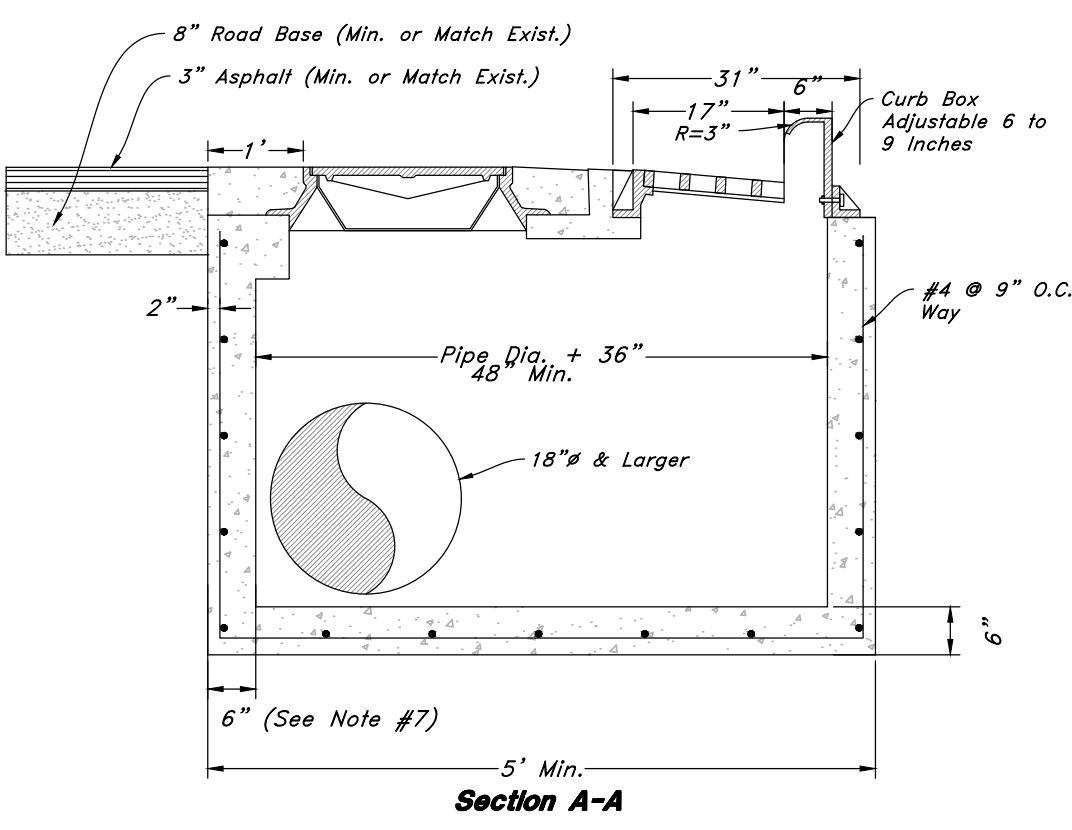

- Notes:**
- All reinforcement shall be #4 deformed steel, grade 60 KSI per APWA 03 20 00.
  - All reinforcement shall be placed at 9" O.C. each way in the floor and the walls.
  - The cleanout cover shall be model A-1181 as manufactured by D & L Supply or acceptable equal.
  - The adjustable curb box inlet grate shall be bicycle safe (Olympic Foundry I-3517 or acceptable equal).
  - Concrete shall be Class 4,000 per APWA 03 30 04.
  - All pipes in the box shall be cut with the interior of the box and grouted smooth.
  - Wall thickness shall be increased to 8" for pipes 36" or larger.
  - Rebar shall have 2" clear on earth side of structure.
  - Frame must touch wall on a minimum of 3 sides.
  - If a precast box has been allowed, a concrete collar shall be poured at all connections.

**2 Combo Box**  
Not to Scale

Is there a cross section of the trail improvements?

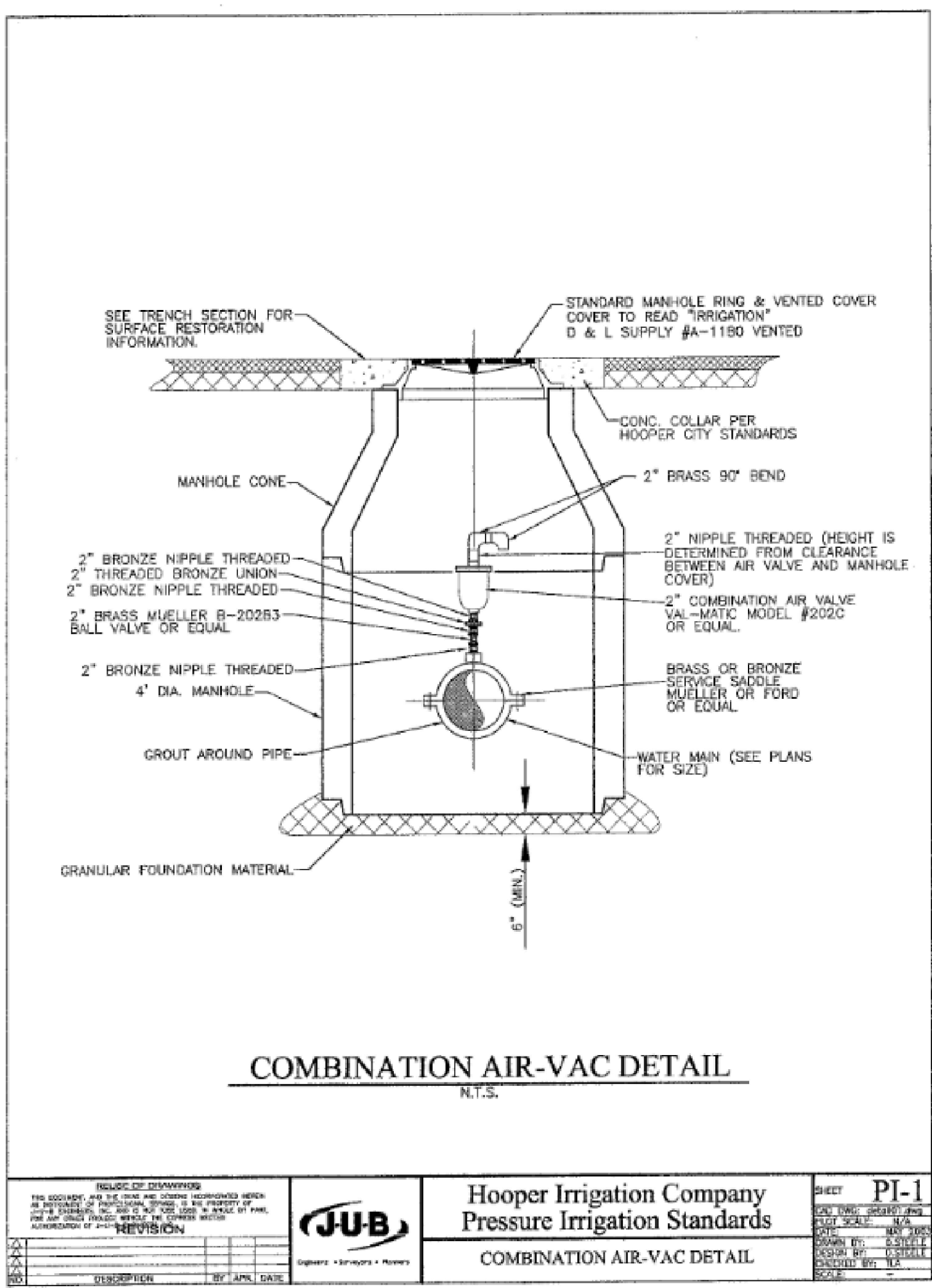

**COMBINATION AIR-VAC DETAIL**  
N.T.S.

<p>REVISIONS</p> <p>NO. DESCRIPTION</p>	<p>Hooper Irrigation Company Pressure Irrigation Standards</p> <p>COMBINATION AIR-VAC DETAIL</p>	<p>SHEET <b>PI-1</b></p>
---	--	--------------------------

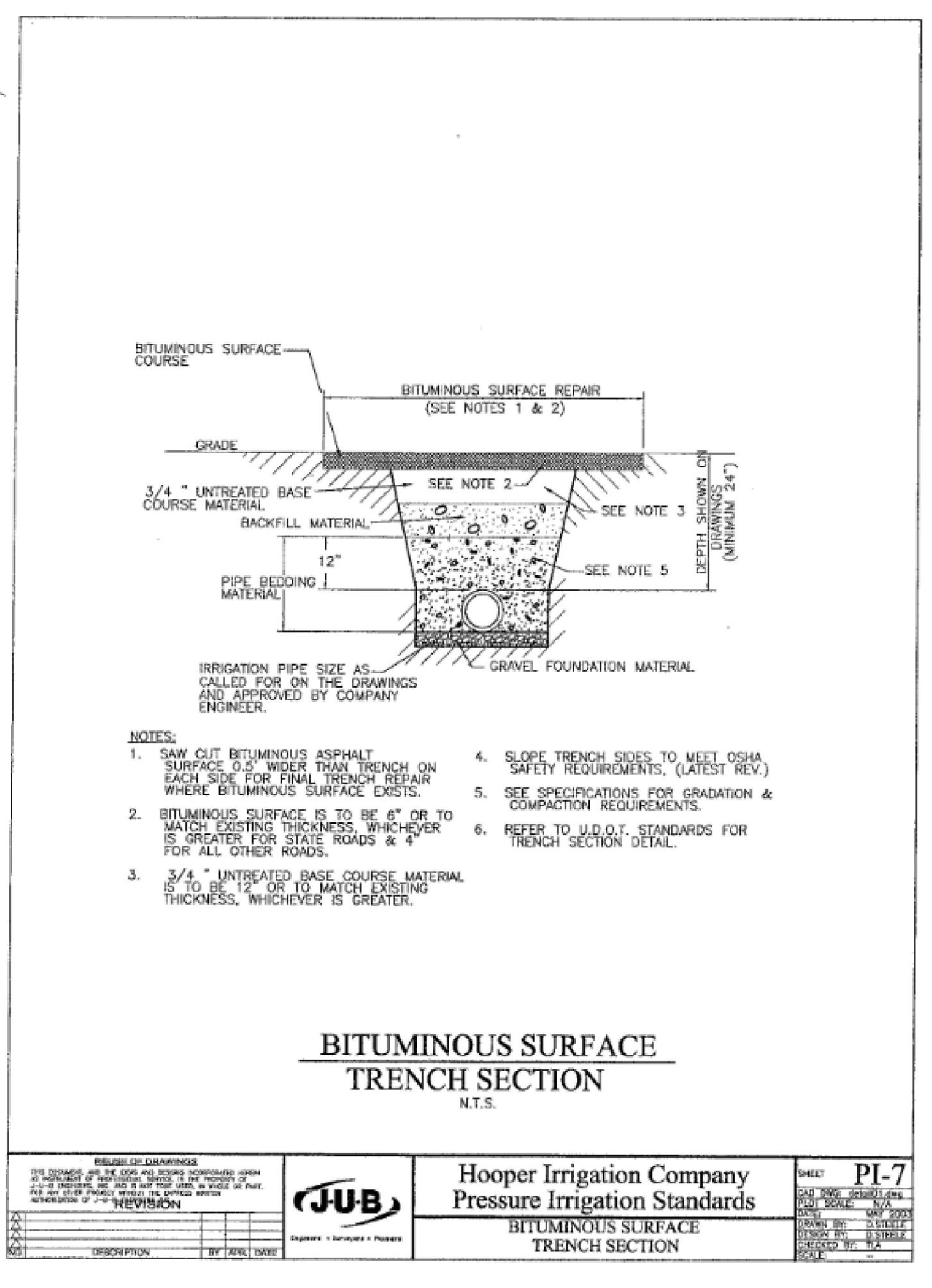

**BITUMINOUS SURFACE TRENCH SECTION**  
N.T.S.

<p>REVISIONS</p> <p>NO. DESCRIPTION</p>	<p>Hooper Irrigation Company Pressure Irrigation Standards</p> <p>BITUMINOUS SURFACE TRENCH SECTION</p>	<p>SHEET <b>PI-7</b></p>
---	---	--------------------------

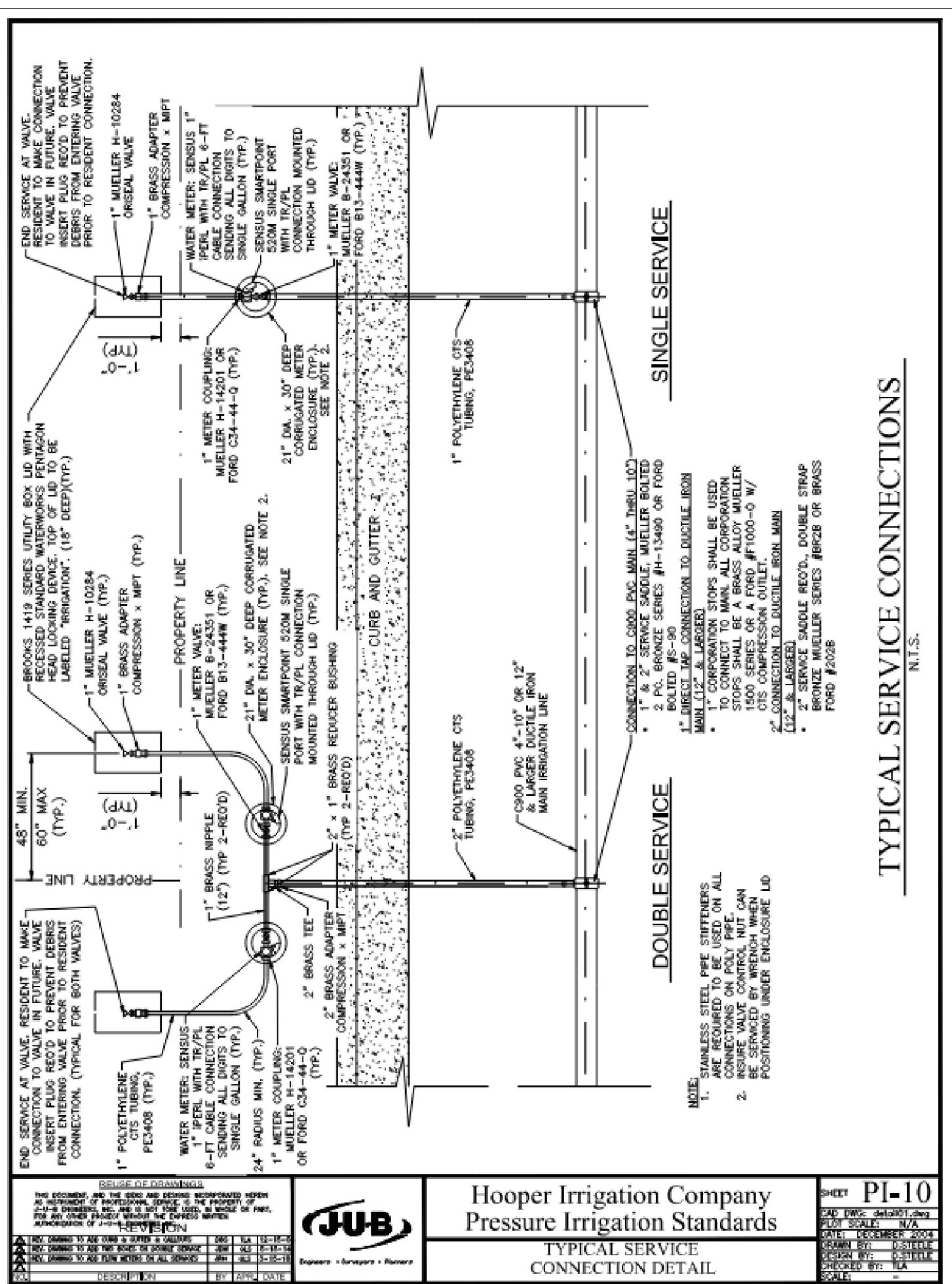

**TYPICAL SERVICE CONNECTIONS**  
N.T.S.

<p>REVISIONS</p> <p>NO. DESCRIPTION</p>	<p>Hooper Irrigation Company Pressure Irrigation Standards</p> <p>TYPICAL SERVICE CONNECTION DETAIL</p>	<p>SHEET <b>PI-10</b></p>
---	---	---------------------------

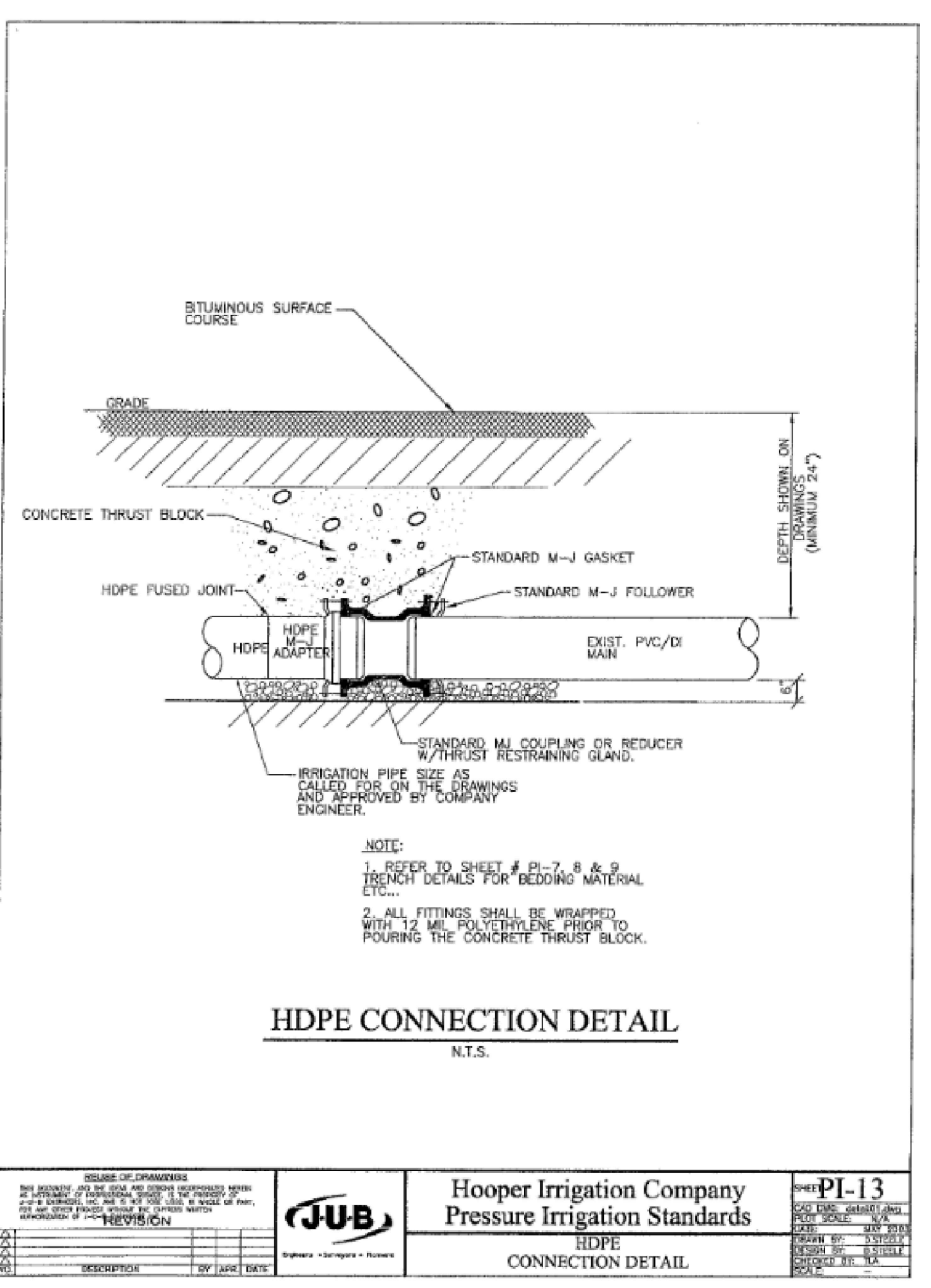

**HDPE CONNECTION DETAIL**  
N.T.S.

<p>REVISIONS</p> <p>NO. DESCRIPTION</p>	<p>Hooper Irrigation Company Pressure Irrigation Standards</p> <p>HDPE CONNECTION DETAIL</p>	<p>SHEET <b>PI-13</b></p>
---	--	---------------------------

**GREAT BASIN ENGINEERING**

5746 SOUTH 1475 EAST, OGDEN, UTAH 84403  
 MAIN 801.345.1754 FAX 801.392.7504  
 WWW.GRETBASINENGINEERING.COM

**Details**

**Riverbend Farm Phase 2**

A part of the Southeast Quarter of Section 16 and the West Half of Section 15, T6N, R2W, S18&M, Weber County, Utah

February 2024

SHEET NO. **C7**

NOT FOR CONSTRUCTION

