



Land Use Permit

Weber County Planning Commission

2380 Washington Blvd. STE 240

Ogden, UT 84401

Phone: (801) 399-8791 FAX: (801) 399-8862

webercountyutah.gov/planning

Permit Number: LUP359-2023

Permit Type: Structure

Permit Date: 10/20/2023

Applicant

Name: Jason Ellis
Business:
Address:
, UT
Phone: 435-932-6735

Owner

Name: William White
Business:
Address: 1250 S 9500 E
Huntsville, UT 84317
Phone: 801-518-7422

Parcel

Parcel: 210350095

Zoning: FV-3 **Area:** 38.82 **Sq Ft:**

Address: , UT

Lot(s):

Subdivision:

T - R - S - QS: 6N - 2E - 21 -

Proposal

Proposed Structure: Ag Bldg 1

Proposed Structure Height: 25

of Dwelling Units: 0

Off Street Parking Reqd:

Building Footprint: 6000

Max Structure Height in Zone: 35

of Accessory Bldgs: 3

***Is Structure > 1,000 Sq. Ft?** No

*If True Need Certif. Statement

Permit Checklist

Access Type: Public

Greater than 4218 ft above sea level? Yes

Additional Setback Reqd. ? No

> 200 ft from paved Road? No

Culinary Water District:

Alternative Access File #

Wetlands/Flood Zone? No

Meet Zone Area Frontage? Yes

Hillside Review Reqd? No

Waste Water System:

Comments

This structure qualifies for the Agricultural Exemption because the structure will be exclusively for agriculture-related uses within an agricultural parcel.

Land Use Permit

Structure Setback Graphic: Barn, Corral, or Stable

****See additional notes in the comments section****

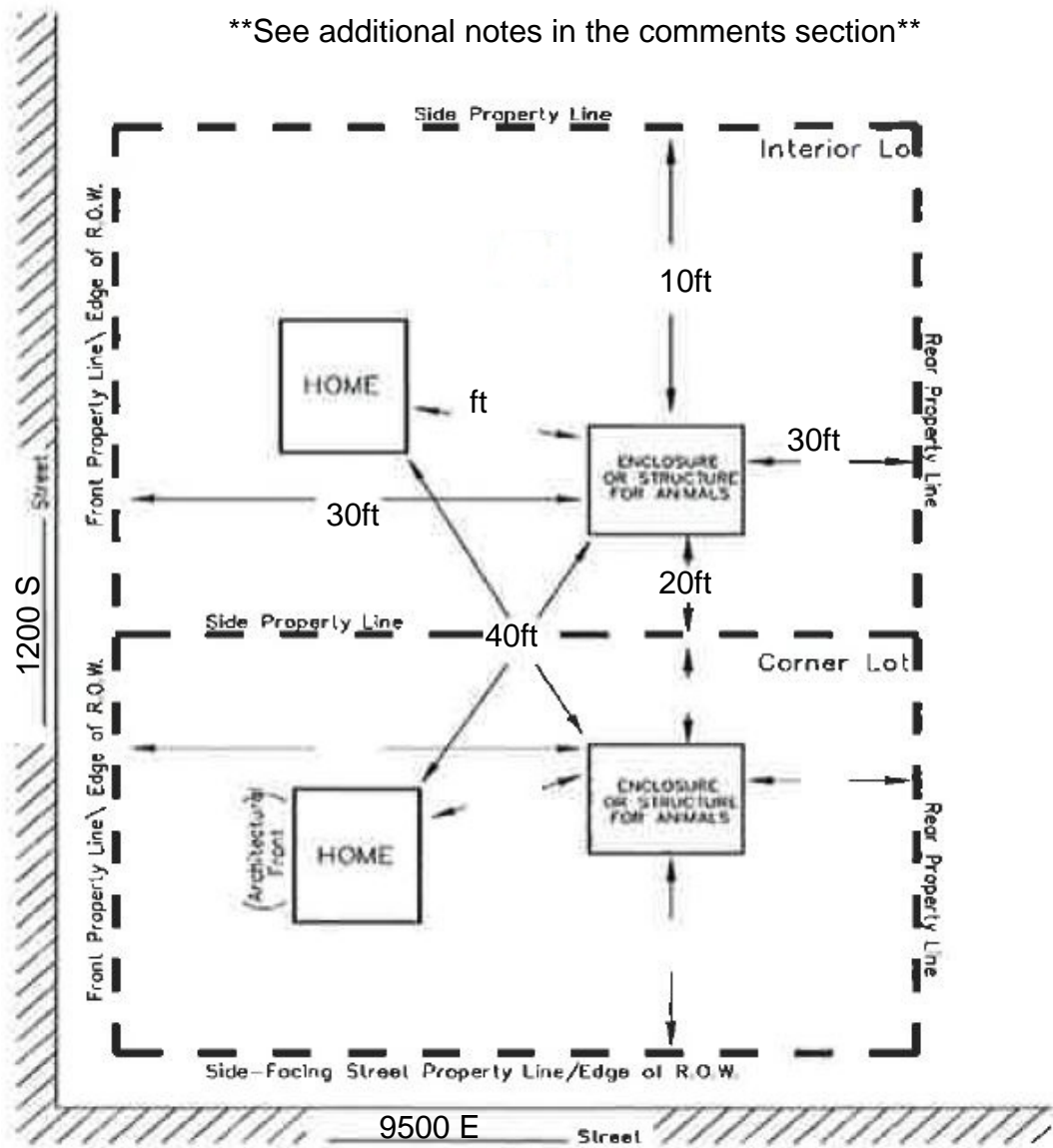

MINIMUM YARD SETBACKS Barn, Corral, or Stable

NOTICE FOR APPLICANT (Please Read Before Signing)

Proposals for the installation of an individual water supply and for a sanitary waste disposal system (septic tank) for any structure designed for human occupation must be approved by Weber County Health Department prior to installation.

Felix Lleverino

10/20/2023

Planning Dept. Signature of Approval

Date

I hereby certify that I have read and examined this application and know the same to be true and correct. All provisions of laws and ordinances governing this land use will be complied with whether specified herein or not. I make this statement under penalty of perjury.

Contractor/Owner Signature of Approval

Date