



Land Use Permit

Weber County Planning Commission

2380 Washington Blvd. STE 240
Ogden, UT 84401
Phone: (801) 399-8791 FAX: (801) 399-8862
webercountyutah.gov/planning

Permit Number: LUP338-2023

Permit Type: Structure
Permit Date: 10/12/2023

Applicant

Name: Keylee Ball
Business:
Address: 2405 N Highway 158
Eden, UT 84310
Phone: 801-814-3410

Owner

Name: Gage Froerer
Business:
Address: , UT
Phone:

Parcel

Parcel: 222860002
Zoning: CV-2 **Area:** .6004 **Sq Ft:**
Address: , UT

Lot(s): **Subdivision:**
T - R - S - QS: 7N - 1E - 34 -

Proposal

Proposed Structure: Wall sign
Proposed Structure Height: 0
of Dwelling Units: 0
Off Street Parking Reqd: 0

Building Footprint: 0
Max Structure Height in Zone: 0
of Accessory Bldgs: 0
***Is Structure > 1,000 Sq. Ft?** N/A
***If True Need Certif. Statement**

Permit Checklist

Access Type: Across front lot line
Greater than 4218 ft above sea level? N/A
Additional Setback Reqd. ? N/A
> 200 ft from paved Road? N/A
Culinary Water District: NA

Alternative Access File #
Wetlands/Flood Zone? N/A
Meet Zone Area Frontage? N/A
Hillside Review Reqd? N/A
Waste Water System: NA

Comments

Sign is not proposed to be illuminated. Sign size complies with wall sign allowance in CV-2 zone.

Land Use Permit

Structure Setback Graphic: New Dwelling, Addition, Etc.

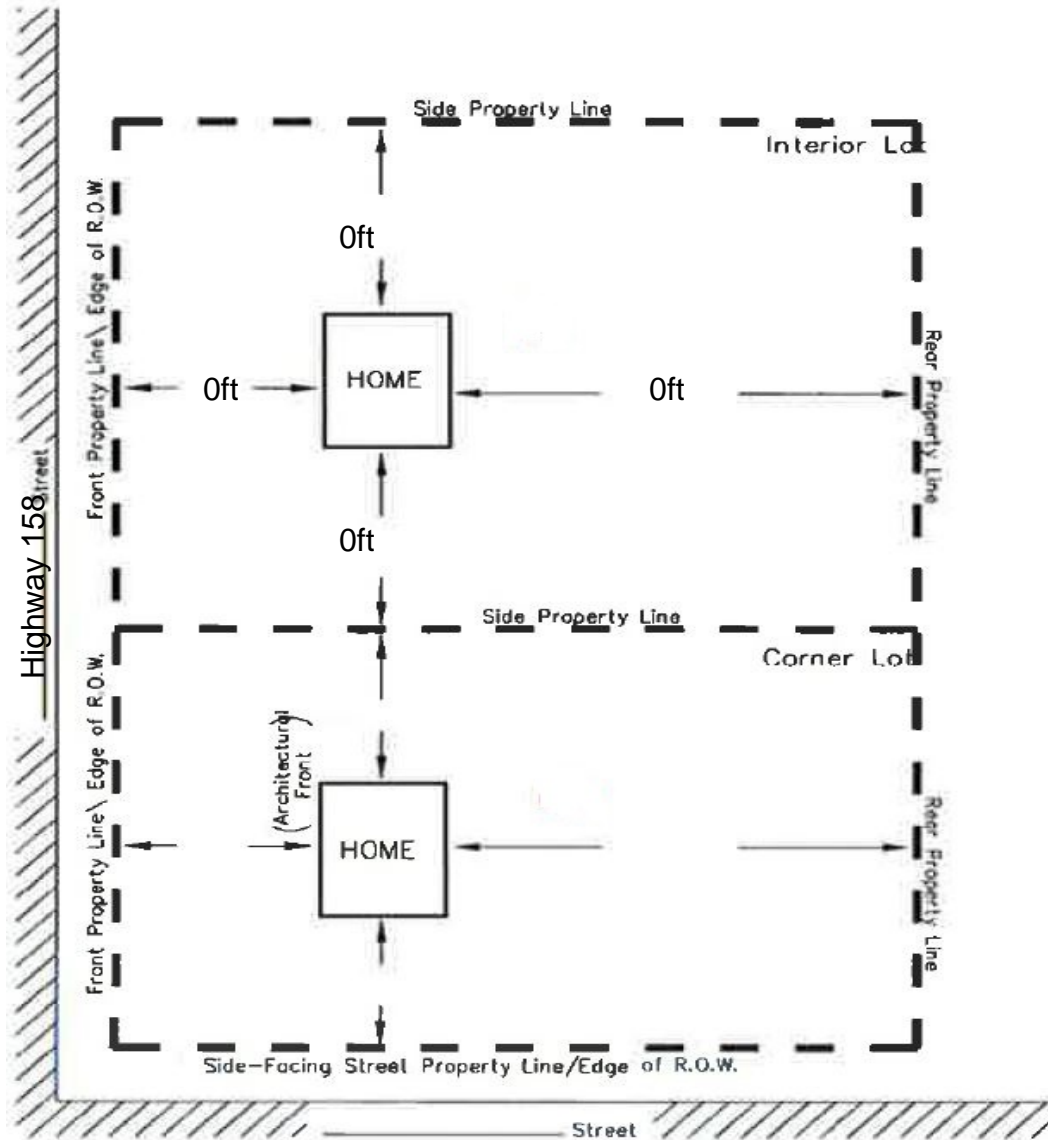

MINIMUM YARD SETBACKS New Dwelling, Addition, Etc.

NOTICE FOR APPLICANT (Please Read Before Signing)

Proposals for the installation of an individual water supply and for a sanitary waste disposal system (septic tank) for any structure designed for human occupation must be approved by Weber County Health Department prior to installation.

Steven Burton

10/12/2023

Planning Dept. Signature of Approval

Date

I hereby certify that I have read and examined this application and know the same to be true and correct. All provisions of laws and ordinances governing this land use will be complied with whether specified herein or not. I make this statement under penalty of perjury.

Contractor/Owner Signature of Approval

Date