



OGDEN VALLEY PLANNING COMMISSION

MEETING AGENDA

September 26, 2023
Pre-meeting 4:30pm/Regular Meeting
5:00pm-6:00pm No Zoom



- *Pledge of Allegiance*
- *Roll Call:*

1. Minutes: July 18, 2023

Petitions, Applications, and Public Hearings:

2. Administrative Items:

2.1UVV071123: Consideration and action on a request for preliminary approval of the Village Nests Retreat at Powder Mountain, located at 5780 N Daybreak Ridge, Eden. **Planner: Steve Burton**

2.2 CUP2023-12: Request for approval of a conditional use permit for the Osprey sewer lift station located at approximately 1900 N Highway 158, Eden. **Planner: Tammy Aydelotte**

2.3 CUP2023-11: Request for approval of a conditional use permit for the Brown sewer lift station located at approximately 5204 E Highway 166, Eden. **Planner: Tammy Aydelotte**

3. Training from Legal Counsel

Adjourn to Public Open House –Starts at 6:00pm

- ❖ Presentation from Rocky Mountain Power- Kirk Nigro
- ❖ Presentation from Planning Director Rick Grover regarding to Ogden Valley General Plan and the Valley's Future Buildout
- ❖ Public Open House regarding the Ogden Valley General Plan and the Valley's Future Buildout (Questions and comments will be taken at this time).

***The regular meeting will be held in person at the Ogden Valley Branch Library 131 S 7400 E Huntsville UT 84317
No ZOOM for this Meeting***

A Pre-Meeting will be held at 4:30 p.m. The agenda for the pre-meeting consists of discussion of the same items listed above, on the agenda for the meeting. No decisions are made in the pre-meeting, but it is an open public meeting.

In compliance with the Americans with Disabilities Act, persons needing auxiliary services for these meetings should call the Weber County Planning Commission at 801-399-8761

Meeting Procedures

Outline of Meeting Procedures:

- ❖ The Chair will call the meeting to order, read the opening meeting statement, and then introduce the item.
- ❖ The typical order is for consent items, old business, and then any new business.
- ❖ Please respect the right of other participants to see, hear, and fully participate in the proceedings. In this regard, anyone who becomes disruptive, or refuses to follow the outlined procedures, is subject to removal from the meeting.

Role of Staff:

- ❖ Staff will review the staff report, address the approval criteria, and give a recommendation on the application.
- ❖ The Staff recommendation is based on conformance to the general plan and meeting the ordinance approval criteria.

Role of the Applicant:

- ❖ The applicant will outline the nature of the request and present supporting evidence.
- ❖ The applicant will address any questions the Planning Commission may have.

Role of the Planning Commission:

- ❖ To judge applications based upon the ordinance criteria, not emotions.
- ❖ The Planning Commission's decision is based upon making findings consistent with the ordinance criteria.

Public Comment:

- ❖ The meeting will then be open for either public hearing or comment. Persons in support of and in opposition to the application or item for discussion will provide input and comments.
- ❖ The commission may impose time limits for comment to facilitate the business of the Planning Commission.

Planning Commission Action:

- ❖ The Chair will then close the agenda item from any further public comments. Staff is asked if they have further comments or recommendations.
- ❖ A Planning Commissioner makes a motion and second, then the Planning Commission deliberates the issue. The Planning Commission may ask questions for further clarification.
- ❖ The Chair then calls for a vote and announces the decision.

Commenting at Public Meetings and Public Hearings

Address the Decision Makers:

- ❖ When commenting please step to the podium and state your name and address.
- ❖ Please speak into the microphone as the proceedings are being recorded and will be transcribed to written minutes.
- ❖ All comments must be directed toward the matter at hand.
- ❖ All questions must be directed to the Planning Commission.
- ❖ The Planning Commission is grateful and appreciative when comments are pertinent, well organized, and directed specifically to the matter at hand.

Speak to the Point:

- ❖ Do your homework. Obtain the criteria upon which the Planning Commission will base their decision. Know the facts. Don't rely on hearsay and rumor.
- ❖ The application is available for review in the Planning Division office.
- ❖ Speak to the criteria outlined in the ordinances.
- ❖ Don't repeat information that has already been given. If you agree with previous comments, then state that you agree with that comment.
- ❖ Support your arguments with relevant facts and figures.
- ❖ Data should never be distorted to suit your argument; credibility and accuracy are important assets.
- ❖ State your position and your recommendations.

Handouts:

- ❖ Written statements should be accurate and either typed or neatly handwritten with enough copies (10) for the Planning Commission, Staff, and the recorder of the minutes.
- ❖ Handouts and pictures presented as part of the record will be left with the Planning Commission.

Remember Your Objective:

- ❖ Keep your emotions under control, be polite, and be respectful.
- ❖ It does not do your cause any good to anger, alienate, or antagonize the group you are standing in front of.

Minutes of the Joint Work Session of the Ogden Valley Planning Commission and the Weber County Commission and Regular Meeting of the Ogden Valley Planning Commission for July 18, 2023. To join the meeting, please navigate to the following weblink at, <https://us02web.zoom.us/j/87394185153>, the time of the meeting, commencing at 4:00 p.m.

Ogden Valley Planning Commissioners Present: Trevor Shuman, Chair, Jeff Barber, Dayson Johnson, Jared Montgomery, Justin Torman, and Janet Wampler.

Weber County Commissioners Present: Sharon Bolos, Gage Froerer, James H. "Jim" Harvey.

Absent/Excused: Jeff Burton.

Staff Present: Rick Grover, Planning Director; Charlie Ewert, Principal Planner; Steve Burton, Planner; Felix Lleverino, Planner; Tammy Aydelotte, Planner; Bill Cobabe, Planner; Courtlan Erickson, Legal Counsel; Marta Borchert, Office Specialist.

JWS 1: A special joint work session with the County Commission and Ogden Valley Planning Commission to discuss proposed amendments to the Form Based Zone. The proposed changes will amend the area's Street Regulating Plan and the area's allowed architectural theme.

Commissioner Froerer stated there seems to be some concern about the most recent version of the County's General Plan, which was developed and adopted in 2017; there seems to be some disagreement in the public realm as to whether the Plan is being followed or if it is the proper plan to follow. He invited Commissioner Harvey to provide some background information regarding the development of the Plan. Commissioner Harvey discussed planning efforts for the Ogden Valley area and stated he feels that the current Plan reflects the desires of the many residents in the Valley who were involved in the public process that informed the Plan.

Commissioner Froerer asked Principal Planner Ewert to discuss the basics of the General Plan in terms of density and transferring density to a village area. Mr. Ewert stated that a density analysis was conducted in 2016 to determine the buildout of the Valley floor and the number derived from that analysis was 16,000 total dwelling units. This does not mean the County has the authority to not approve that number of units; it means that that 16,000 units will exist at some point in time as they are development rights associated with the land in the Valley. There were already 4,000 dwelling units built at that time and staff understood this analysis meant there would be an additional 10,000 to 12,000 dwellings built eventually. The 4,000 number included resort units and last year staff felt it appropriate to reevaluate density rights according to current zoning and existing parcel layers; they found that the 2016 estimate was low and that all of the resort units could be removed from the calculation and the Valley could still see an additional 16,000 dwelling units. There has been substantial growth since 2016 and there are now between 5,000 and 6,000 dwelling units in the Valley and staff still anticipates there will be additional growth in the Valley. The General Plan anticipates density near infrastructure and services; the idea is to take the density that is spread throughout the open spaces of the Valley and move them to clustered areas where infrastructure exists. This will prevent a scenario where all farmland will evaporate into three acre lots. The next question is how to implement that directive of the General Pan and the Plan has identified eight village centers where density can be transferred: New Town Eden, Old Town Eden, Wolf Creek, Liberty, Nordic, East Huntsville, Snowbasin Intersection (Trappers Loop), and Old Snow Basin Road Intersection. Each of the village areas is an estimated quarter mile radius from the center of the village. There is work to be done to identify which villages will accommodate the greatest amount of development/density, but some decisions have been made related to traffic and infrastructure improvements.

Discussion among the Planning Commission and County Commission centered on the age of the Plan and the perceived need to update it based upon current information; planned infrastructure projects in the Ogden Valley; growth projections for the entire State and Weber County; the risk of litigation if the County chooses to take away the private property rights of property owners in the Valley; and a possible misrepresentation of the recommendations that were made by the Planning Commission regarding the Form Based Zone. Commissioner Wampler communicated the reasons for the negative recommendation from the Planning Commission and the Planning Commission's desire for multiple issues to be separated from one another rather than combined as part of one issue for which the County Commission is seeking a recommendation from the Planning Commission. Commissioner Froerer noted the Council Commission has authorized Planning staff to separate the issues for which they are seeking a recommendation; the Street Regulating Plan should also be simplified as much as possible, and staff has been asked to scale the Plan back to something as simple as a guiding document for the next 10 to 15 years. Architectural themes will also be an

independent issue that the Planning Commission can make a recommendation on. The County Commission is also comfortable waiting longer for a recommendation in order to provide adequate opportunities for public notice and input on the two issues. Continued discussion among the group centered on the need to clearly define the term 'open space'; the need to improve motions made by the Planning Commission in order for the group's intent to be clearly communicated to the County Commission; a request for the County Commission to direct Planning staff to give the Planning Commission greater control of their agenda and meeting packets and to break down action items into smaller pieces;

Principal Planner Ewert reviewed a memo he included in the meeting packet; Planning staff have discussed with the County Commission the Planning Commission's recent recommendation regarding the amendments to the Form-Based Zone relating to the proposed Eden Crossing development. The County Commission desires to discuss the recommendation with the Planning Commission to better understand the reason for the negative recommendation and the Planning Commission's desires for the area. The County Commission has also requested that to divide the proposed amendments into two components; first, the proposed architectural theme amendments, and second, the proposed street regulating plan amendments. This memo concerns the street regulating plan amendments and provided three options that the County Commission has considered in addition to the options that the Planning Commission reviewed.

The Joint Work Session adjourned at 5:18 p.m.

Regular Meeting

- **Pledge of Allegiance**
- **Roll Call:**

Chair Shuman called the regular meeting to order at 6:00 p.m.; he conducted roll call and indicated all Commissioners were in attendance, with the exception of Vice Chair Burton, who was excused.

1. Minutes: May 23, 2023.

Chair Shuman noted Commissioner Wampler has sent an email to the Planning Commission and Office Specialist Borchert; he declared the minutes will be approved as amended by Commissioner Wampler.

2. Consent items:

2.1 DR2023-04: Request for approval on a design review application for parking expansion of the existing Canyon Rim parking lot for Snow Basin Resort. Planner: Tammy Aydelotte

A staff memo from Planner Aydelotte explained the applicant is requesting approval of a design review for Snowbasin Resort Company, to expand the Canyon Rim Parking lot by an additional 124 parking spaces. This request has been submitted in order to accommodate an increase in resort visitors. The application is being processed as an administrative review due to the approval procedures in Uniform Land Use Code of Weber County, Utah (LUC) §108-1-2 which requires the Planning Commission to review and approve applications for conditional use permits and design reviews. Staff recommends approval of the Snowbasin Design Review Application. This recommendation is conditioned upon all review agency requirements, and the following conditions:

1. Written approval of the design shall not be issued until all review agency requirements have been met (Engineering).
2. Any additions/changes to existing signage, or additions/changes to existing exterior lighting must be approved by the Planning Department.

This recommendation is based on the following findings:

1. Parking lots are allowed as an accessory to the main use within the DRR-1 zone.
2. The applicant has demonstrated compliance with the applicable land use codes.

Commissioner Torman moved to approve application DR2023-04, request for approval of a design review application for parking expansion of the existing Canyon Rim parking lot for Snow Basin Resort, based upon the findings and subject to the conditions listed in the staff report. Commissioner Barber seconded the motion. Commissioners Barber, Johnson, Montgomery, Torman, Shuman, and Wampler all voted aye. (Motion carried 6-0). Commissioner Burton was not present when this vote was taken.

Petitions, Applications, and Public Hearings:

3. Legislative Items:**3.1 ZTA 2023-04: A public hearing to consider a county-initiated ordinance amendment to implement water-wise landscaping regulations that align with the Weber Basin Water Conservancy District turf removal incentives. Planner: Steve Burton**

Planner Burton explained Weber Basin Water Conservancy District (WBWCD) is administering water-wise landscaping incentives to communities that have adopted specific landscaping requirements intended to restrict the use of irrigated turf grass. The attached ordinance amendments will implement Weber Basin's landscaping requirements for municipalities and counties to adopt, and if adopted, will allow residents in unincorporated Weber County to participate in the District's "Flip your Strip" and "Landscape Lawn Exchange" programs. The most notable change to the current landscaping regulations is the addition of 108-7-12 titled "Water-wise Landscaping". This section restricts new single-family residential developments from having no more than 35 percent of the front and side yard of a lot or parcel to include irrigated turf grass, and no more than 3,000 square feet of total lot area to be irrigated turf grass. The section also restricts commercial, industrial, institutional, and multi-family residential developments to having no more than 15 percent of the total landscaped area to be irrigated turf grass. Both the Western Weber General Plan and the Ogden Valley General Plan anticipate that the county will consider new water conservation methods. Staff recommends that the Planning Commission consider ZTA 2023-04 and if the Planning Commission approves, the Planning Commission may forward a positive recommendation to the County Commission for the proposal. This recommendation may come with the following findings:

1. The proposal helps to accomplish a general plan goal or policy related to water conservation.

Mr. Burton then facilitated a review of the proposed text amendments, making note of the amendments that will apply to residential areas and the amendments that will apply to commercial/institutional/manufacturing/multi-family residential areas. He also highlighted the new section of the ordinance that does implement WBWCD's incentives for waterwise landscaping on new development.

Chair Shuman inquired as to any of the ordinance amendments that would be applied if someone were to make an application to make an adjustment to their own property, such as an accessory dwelling unit (ADU) on their property. He asked if this ordinance would make his park strip illegal. Mr. Burton stated that he does not think that is the case because the project would not be a new development. Chair Shuman asked if the answer were be different he were subdividing his lot; if he has a six acre lot and he chose to divide it into two three acre lots, would the proposed ordinance apply. Mr. Burton answered yes; a subdivision would be defined as new development and the water-wise landscaping regulations would apply to the new lot. Chair Shuman added the same would be true for someone with a substantial amount of land that they would like to subdivide into smaller lots to allow their family to build upon; that person would be responsible for implementing water-wise landscaping throughout the entire development. He then asked if the majority of the code amendments do not apply to single-family homeowners. Mr. Burton answered yes; only the last section of the ordinance, 108-7-12, would apply to a single-family lot.

Commissioner Wampler stated she feels it necessary to include language in the ordinance to clearly define 'new development' for the purposes of requiring water wise landscaping. Mr. Burton agreed that would be appropriate.

Commissioner Torman asked if the recommendations of WBWCD were specific to the Ogden Valley or their service area as a whole. Mr. Burton stated it would be his guess that WBWCD did not specifically consider Ogden Valley. Commissioner Torman noted there are larger lots in the Ogden Valley area than in other areas of unincorporated Weber County; there are not many park strips in the Ogden Valley. Commissioner Barber agreed and stated it would be helpful for the Planning Commission to hear from WBWCD regarding their feelings about the proposed ordinance amendments. Mr. Burton stated that Planning staff has been in contact with WBWCD. Planning Director Grover indicated Planning staff did not know that the Planning Commission wanted a representative of WBWCD to attend this meeting. Commissioner Barber stated it would make sense for the Planning Commission to hear from the District; the Ogden Valley environment and weather system is much different than other areas of the County. Mr. Grover indicated staff did notify WBWCD that the Planning Commission did not want to apply water wise landscaping requirements to the Ogden Valley, but they have not heard a response from the District regarding that matter.

Commissioner Montgomery stated that he is supportive of water-wise landscaping, but the Environmental Protection Agency (EPA) has cautioned against creating an urban island heat effect by removing large grassy areas and replacing them with other materials that will actually increase energy costs, pollution, heat related illness, and mortality. He asked if solving one problem will only create another problem and he would like to hear from the WBWCD on that issue. This led to high level discussion of the types of materials that could be used to replace grassy areas, with Commissioner Montgomery reiterating that the Ogden Valley planning area is much different than the Western Weber area and that should be taken into consideration when imposing

Chair Shuman noted another concern that he has is that due to water conservation efforts in recent years, the water companies have realized they do not have money in their coffers because of reduced usage. They are charging more for water, even though usage has decreased. He still does not want to change the landscaping requirements for the Ogden Valley. Commissioner Barber agreed; he noted the General Plan for the Ogden Valley mentions the natural state of the Valley throughout. He emphasized the natural state is not rock or other water-wise landscaping elements; instead, it is green most of the year and would consider the proposal contrary to the General Plan.

Commissioner Montgomery moved to open the public hearing regarding ZTA 2023-04. Commissioner Johnson seconded the motion. Commissioners Barber, Johnson, Montgomery, Torman, Shuman, and Wampler all voted aye. (Motion carried 6-0). Commissioner Burton was not present when this vote was taken.

Emma Francis stated that it is correct that the Ogden Valley is different from Western Weber County; the pioneers came to this area and discovered grasses taller than horses, wildflowers everywhere, and springs throughout the Valley. This would be a significant change to the habitat and natural state of the Valley. She wrote an editorial in the last edition of the newspaper discussing the efforts of water companies to eliminate green space. She attended a session on this matter at a recent American Planning Association (APA) conference and she learned science about heat islands, blacktop, roofs, and rock collecting heat and contributing to droughts. The higher temperatures make cloud cover pass over areas without releasing water. The bottom line is that less green space contributes to drought; green space, however, improves mental health, lowers blood pressure and heart rates, improves physical health, cleans the air we breathe, and cleans surface water. When walking to this meeting, she noticed the heat radiating off of rock that has been used in landscaping around the building; even the plants that are planted in the rock are dying because of the heat. Grass is not present to clean storm water and minimize flooding. She cited other positive aspects of grass as proven by scientific studies and concluded turf does not need as much water as many believe and people should be encouraged to accept dormant lawns in the summer months rather than replace lawn with other materials. Education is key when discussing water conservation. She cited the boom of apartment development in Western Weber County; green spaces are being eliminated and there is no place for kids to play outside. Natural animal habitats are being eliminated as well and soil is being sterilized, which has a negative impact on the environment. Green space helps cool the environment, retains clean air and water, lowers crime rates in urban areas, and improves physical and mental health. As Utah becomes more urbanized, green space is needed more than ever. She feels the water companies have a conflict of interest and should not be recommending these types of ordinances. Science does not support the elimination of turf.

Janice Campbell agreed that the Ogden Valley has a separate and unique climate from other areas of Weber County. The area where she lives is a zone three or four and that is much different than other areas of the Valley and it is completely surrounded by natural forest and there is a need to sustain the wildlife in the area. Water on the ground is needed to allow the vegetation and gardens to grow, clean the air, and keep the water cycle going.

There were no additional persons appearing to be heard.

Commissioner Montgomery moved to close the public hearing regarding ZTA 2023-04. Commissioner Torman seconded the motion. Commissioners Barber, Johnson, Montgomery, Torman, Shuman, and Wampler all voted aye. (Motion carried 6-0). Commissioner Burton was not present when this vote was taken.

Commissioner Wampler stated that while a number of the Planning Commissioners are concerned about the proposed new regulations, they also do not want to prevent a resident of the Valley from participating in the WBWCD incentive program if they wish to; it is unfortunate that it appears that the County must adopt the proposed ordinance amendments in order for residents to participate.

Commissioner Johnson moved to forward a negative recommendation to the County Commission regarding ZTA 2023-04, a County initiated ordinance amendment to implement water-wise landscaping regulations that align with the Weber Basin Water Conservancy District turf removal incentives, based on the finding that the ordinance is not consistent with the Ogden Valley General Plan, it is not in the best interest of the general public, and is not good for the health and safety of the general public. The Planning Commission would also like to request that residents be allowed to participate in the WBWCD incentive program without the proposed ordinance being codified. Commissioner Wampler seconded the motion. Commissioners Barber, Johnson, Montgomery, Torman, Shuman, and Wampler all voted aye. (Motion carried 6-0). Commissioner Burton was not present when

4. Public Comment for Items not on the Agenda:

There were no public comments.

5. Remarks from Planning Commissioners:

Commissioner Johnson stated that he had the opportunity to meet with the Political Action Committee (PAC) that proposed legislation relating to matters coming forward from the Planning Commission to the County Commission and approval authorities for various land use matters; he asked if there is a time that the Planning Commission can be updated and trained on that matter. Planning Director Grover noted that Planning staff is encouraging the Planning Commission to attend the Utah Chapter of the American Planning Association (APA) Planning Conference in September and there will be a great deal of training on that issue. The County will pay for each Planning Commissioners attendance, and it is being hosted in Weber County September 18-29.

6. Planning Director Report:

Planning Director Grover indicated he had nothing to report.

7. Remarks from Legal Counsel

There were no remarks from Legal Counsel.

Adjourn to Work Session

WS1: A work session to continue the Planning Commission's review of proposed changes to the Agritourism ordinance, and the proposal to add agritourism as a conditional use in the S-1 zone.

Principal Planner Ewert noted that during the Planning Commission's last work session, the Commission and staff reviewed proposed changes to the agritourism ordinance. The review was not completed, but staff suggested they would make the changes discussed in the meeting and send them out by email to get a jump start on the discussion during this work session. Due to time constraints, staff was unable to send the email, and instead those proposed changes were provided in the meeting packet. There is one redlined version and one blacklined version. In the redlined version, staff has highlighted the changes requested in the last meeting to make it easier to find and review.

Mr. Ewert facilitated a review of the redlined version of the proposed ordinance amendments; the Commission's discussion centered on the types of uses the Planning Commission would like to list as permitted or conditional agritourism uses; minimum lot sizes for a property to qualify for an agritourism use; conditions that must be present for a property owner to qualify for Green Belt designation and the connection between Green Belt and agritourism; and enforceability of the ordinance.

Chair Shuman invited input from the applicant.

Jon Contos stated that he lives in Ogden and farms land in the County. He noted he feels strongly that it is important to allow agritourism because it is becoming more difficult for farmers to make a living. He referred to the owner of an apple orchard in Utah that has implemented an agritourism use where they sell hard cider that is made from their apples. He hopes the Commission does not get caught up in minimum acreage requirements for an agritourism use; there is a lady by the name is Simbria Patterson in Salt Lake City and she operates a farm on a smaller parcel that does not qualify as Green Belt; it is important that the ordinance recognize smaller, urban farms. His business is Arrowhead Urban Farms, and he has three farming locations where he sells vegetables. Of the 16,000 farms in Utah, a large number of them are small farms and Weber County is a great destination for agriculture and rural experiences for visitors and there are many different types of agritourism uses that are attractive. He cited uses such as fruit/vegetable picking experiences, farm tours, farmers markets, ranch experiences, agricultural festivals, honey and bee keeping uses, and educational workshops. A four-acre parcel in the Ogden Valley may have a 1.5-acre portion where active growing is occurring, but the remaining acreage is not being actively used for agricultural purposes. He does feel there is a place for agritourism, and it can be used to sustain farmers.

Chair Shuman noted the Planning Commission simply wants to be sure that agritourism uses compliment surrounding uses rather than create a negative impact for surrounding properties. Mr. Contos agreed and stated he feels that the language in the proposed ordinance relating to scale of uses will help to regulate that matter.

Shanna Francis stated that her concern is that her next-door neighbor has applied for an agritourism use; she is supportive of farming and agriculture, but prior to this, her neighbor was operating an illegal accessory dwelling unit (ADU). This is an area where short-term rentals (STR) are not allowed. Her neighbor has hired a former planner, Rhonda Kippen, to help him address the issue and has now applied for conditional use for two ADUs plus camp sites for trailers. This will impact surrounding property owners under the guise of a agritourism use. The property is under five acres, and she feels strongly that a minimum lot size is necessary for agritourism. Her neighbor is applying for 12 large events per year with over 100 people at each event and this is very concerning to neighbors. She urged the Commission to set very specific guidelines for agritourism uses.

Chair Shuman addressed Mr. Ewert and asked if the Commission can create an agritourism use that is targeted towards large venues and allow smaller uses to grow organically. This led to philosophical discussion and debate among the Commission and Planning staff regarding appropriate language to include in the ordinance to differentiate between small and large agritourism uses.

Janice Campbell stated she lives in Liberty; it is her understanding the Commission is discussing and considering the possible impacts of over 100 people gathering on a small property. There are already issues with the sewer, septic, and water systems in the Valley and allowing a large number of people to strain the current infrastructure in an unregulated matter does not sound like the best outcome for the County. If people truly want to pursue an agritourism uses, they should secure a business permit, inspections, and agree to proper regulation.

Mr. Ewert indicated the proposed ordinance addresses Ms. Campbell's concerns in the conditional use standards; if a use will overwhelm infrastructure or decrease level of service, that would be a problem that must be addressed before a permit can be issued.

Planning Director Grover expressed concerns about spot zoning if small agritourism operations are permitted; it would be his recommendation that the ordinance address agritourism uses on larger parcels. This led to continued discussion among the Planning Commission regarding minimum lot size for agritourism uses; the Commission concluded that the agritourism use should not be larger than the actual farm on the property to ensure that it is an accessory or incidental use to the farm. They then closely examined different types of agritourism uses listed in the draft ordinance and discussed whether a minimum lot size should be considered for each of these uses.

Mr. Ewert stated he will adjust the proposed ordinance responsive to tonight's discussion and asked the Commission if they are comfortable scheduling a public hearing or if they would like another work session discussion. The Commission concluded they would like to discuss the ordinance in another work session before scheduling a public hearing.

Meeting Adjourned: The meeting adjourned at 8:04 p.m.

Respectfully Submitted,

Weber County Planning Commission



Staff Report to the Ogden Valley Planning Commission

Weber County Planning Division

Synopsis

Application Information

Agenda Item:	UVV071123 Consideration and action on a request for preliminary approval of the Village Nests Retreat at Powder Mountain, located at 5780 N Daybreak Ridge, Eden
Type of Decision:	Administrative
Agenda Date:	Tuesday, September 26, 2023
Applicant:	Rick Everson
File Number:	UVV071123

Property Information

Approximate Address:	5780 N Daybreak Ridge, Eden
Project Area:	3.26 acres
Zoning:	DRR-1
Existing Land Use:	Residential
Proposed Land Use:	Residential
Parcel ID:	23-152-0021

Adjacent Land Use

North:	DRR-1 Resort	South:	DRR-1 Resort
East:	DRR-1 Resort	West:	DRR-1 Resort

Staff Information

Report Presenter:	Steve Burton sburton@webercountyutah.gov 801-399-8766
Report Reviewer:	RG

Applicable Ordinances

- Title 104, Zones, Chapter 29 – Ogden Valley Destination and Recreation Resort Zone (DRR-1)
- Title 106, Subdivisions, Chapters 1-8 as applicable

Background and Summary

This application was accepted for review on July 11, 2023. The proposal is a twenty lot subdivision amending the original twenty lot subdivision called Village Nests East at Powder Mountain. The purpose for the amendment is to take in additional property and change the building envelopes to larger building lots. The proposal complies with the county land use code.

Analysis

General Plan: The proposal is not contrary to the Ogden Valley General Plan, as a master planned resort exists in this location and the owner is continuing to develop in accordance with the master plan and land use code.

Zoning: The property is zoned DRR-1, Destination and Recreation Resort zone. The following is the purpose and intent of the DRR-1 Zone as listed in the land use code.

Sec 104-29-1 Purpose and Intent

The purpose of this chapter is to provide flexible development standards to resorts that are dedicated to preserving open space and creating extraordinary recreational resort experiences while promoting the goals and objectives of the Ogden Valley general plan. It is intended to benefit the residents of the county and the resorts through its ability to preserve the valley's rural character, by utilizing a mechanism that allows landowners to voluntarily transfer development rights to areas that are more suitable for growth when compared to sensitive land areas such as wildlife habitats, hazardous hillsides or prime agricultural parcels. Resorts within an approved destination and recreation resort zone shall, by and large, enhance and diversify quality public recreational opportunities, contribute to the surrounding community's well-being and overall, instill a sense of stewardship for the land.

The DRR-1 zoning ordinance states that there is no minimum lot size and no minimum lot width for the single family dwelling lots, which these lots are intended to be. The lots range in size from 2,900 to 3,900 square feet. Lot widths range in size from 67 feet to 40 feet.

On the previous plat, lot sizes ranged in size from 900 square feet to 1,500 square feet and lot width was 30 feet on all lots.

Culinary water, secondary water, and sanitary sewage disposal: The proposal does not include any new culinary water or sewer connections, and no new letters of approval from Powder Mountain Water and Sewer Improvement District have been requested.

Relation to Adjoining Street Systems/Ogden Valley Pathways: The entire Powder Mountain resort area has sole access through Powder Mountain Road. The development agreement and master plan anticipate a seasonal emergency egress in the future, but one has not yet been required by the county to connect to the recreation subdivisions to the east. This subdivision is not proposing any new lots, and there is no additional impact to county roads with this proposal.

The applicant proposes a private cul-de-sac. Under the subdivision code Sec. 106-2-2.040, the following rules govern a permanently terminal street:

- (a) Permanently terminal street.
 - (1) Maximum length and number of lots. A permanently terminal street (cul-de-sac or dead-end) or permanently terminal street-route shall:
 - a. Serve no more than 15 subdivision lots or lots of record as defined by Section 101-2;
 - b. Provide access to no more than 30 total dwelling units; and
 - c. Have a maximum length of 750 feet. This length shall be measured from the point at which the street or street-route becomes terminal to the furthest extent along the terminal street or terminal street-route. If the terminal street or terminal street-route loops back onto itself, the furthest extent shall be the midpoint of the loop.
 - (2) Alternative allowance due to constraints. If approved by the local fire authority, a permanently terminal street or street-route may serve a maximum of 30 subdivision lots or lots of record, and the maximum length of the street may be waived by the Land Use Authority, as long as the topography or other constraints of the land in the vicinity will not reasonably allow for a street connection to make the street or street-route non-terminal.
 - (3) Turn-around required. A terminal street shall be terminated by a turnaround of not less than 100 feet diameter, or as otherwise required by the local fire authority or the County Engineer. If stormwater drains into the turnaround, a stormwater catch basin and drainage easement shall be provided.

The Fire Marshal has approved the propose cul-de-sac. The applicant has stated that the cul-de-sac does not connect to existing streets because of topography.

Review Agencies: To date, the proposed subdivision has been reviewed by the Planning Division, Weber Fire District, and Weber County Engineering, and the Surveyor's Office. At minimum, all review agency requirements must be addressed and completed prior to this subdivision being recorded.

Staff Recommendation

Staff recommends preliminary approval of UVV071123. This recommendation for approval is subject to all review agency requirements.

This recommendation is based on the following findings:

1. The proposed subdivision conforms to the Ogden Valley General Plan.
2. With the recommended conditions, the proposed subdivision complies with the applicable County ordinances.
3. The proposed subdivision will not be detrimental to the public health, safety, or welfare.
4. The proposed subdivision will not deteriorate the environment of the general area so as to negatively impact surrounding properties and uses.

Exhibits

A. Proposed Preliminary Plat

Location Map

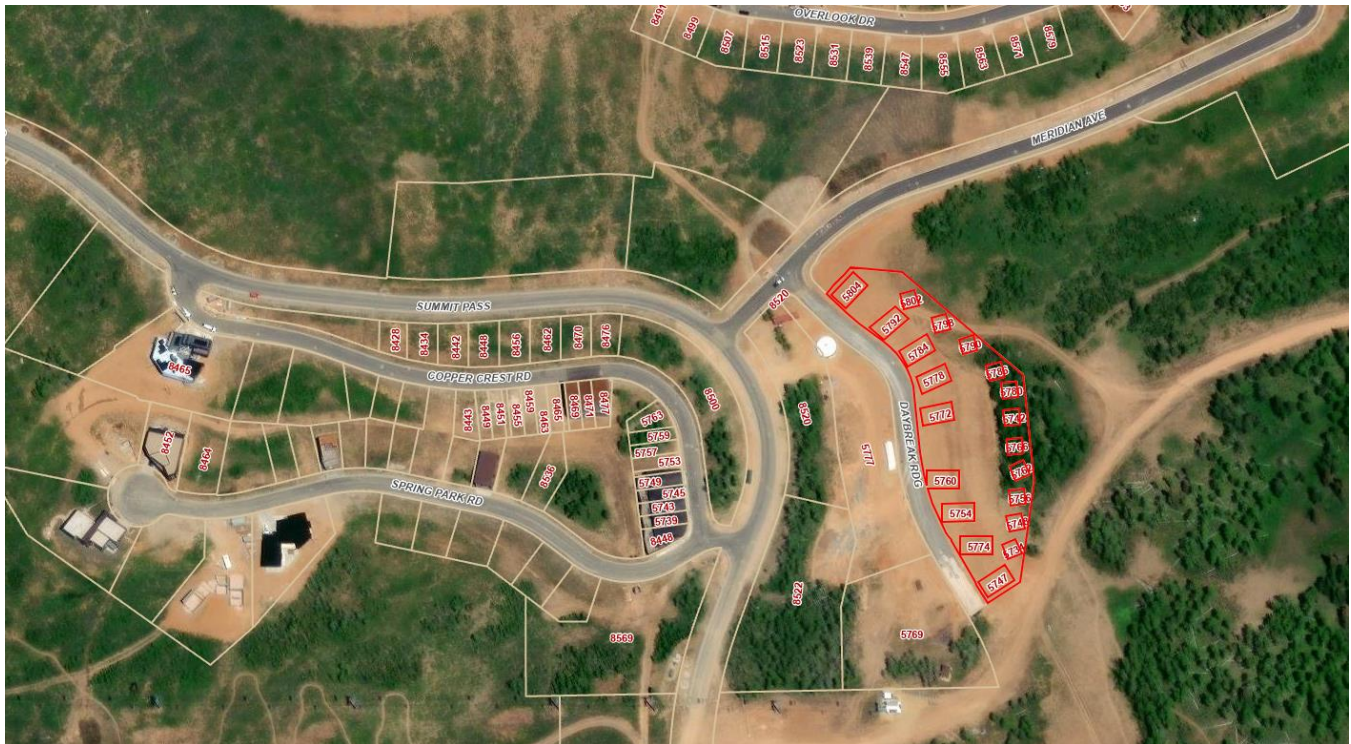

VILLAGE NESTS RETREAT AT POWDER MOUNTAIN
AMENDING VILLAGE NESTS EAST AT POWDER MOUNTAIN-PRUD

LOCATED IN THE NORTHEAST QUARTER OF SECTION 8,
TOWNSHIP 7 NORTH, RANGE 2 EAST,
SALT LAKE BASE AND MERIDIAN, WEBER COUNTY
SEPTEMBER 2023

NOTES:

- 1. SUBDIVISION PLAT IS SUBJECT TO THAT CERTAIN NEIGHBORHOOD DECLARATION OF COVENANTS, CONDITIONS, EASEMENTS AND RESTRICTIONS FOR VILLAGE NESTS RETREAT AT POWDER MOUNTAIN...
2. PURSUANT TO THE NEIGHBORHOOD DECLARATION, THE VILLAGE NESTS RETREAT AT POWDER MOUNTAIN ASSOCIATION, INC., A UTAH NONPROFIT CORPORATION...
3. THE PROPERTY AS DEPICTED ON THIS PLAT IS SUBJECT TO THE RIGHTS OF DECLARANT AS DESCRIBED IN THE NEIGHBORHOOD DECLARATION...
4. THE LOTS ARE SERVED BY PRIVATE WATER AND WASTEWATER LATERAL LINES...
5. ALL UTILITIES WITHIN THE PROJECT SHALL BE UNDERGROUND...
6. DECLARANT HEREBY GRANTS TO ALL UTILITY PROVIDERS AN EASEMENT OVER AND ACROSS ALL COMMON AREAS...
7. ALL COMMON WATER AND SEWER MAINS WITHIN THE COMMUNITY WILL BE OWNED AND MAINTAINED BY POWDER MOUNTAIN WATER AND SEWER IMPROVEMENT DISTRICT...
8. AS FURTHER DESCRIBED IN THE MASTER DECLARATION, ALL LOTS, AND ALL RESIDENCES AND IMPROVEMENTS CONSTRUCTED THEREON...
9. DECLARANT RESERVES FOR THE BENEFIT OF ITSELF, ITS SUCCESSORS AND ASSIGNS, THE RIGHT TO UNILATERALLY AMEND THE PLAT...
10. NOTICE IS HEREBY GIVEN OF THE DECLARANT'S RIGHT TO RESERVE, CREATE AND GRANT EASEMENTS WITHIN ALL COMMON AREA...
11. DECLARANT GIVES NOTICE THAT THE LOTS SHOWN HEREON ARE IN A SKI RESORT AREA...
12. ALL LOTS AS DEPICTED ON THIS PLAT ARE LOCATED IN A LIGHTLY DEVELOPED SEMI-WILDERNESS AREA CONTAINING ANIMALS...
13. DUE TO THE TOPOGRAPHY AND THE LOCATION OF THIS SUBDIVISION, THE NEIGHBORHOOD ASSOCIATION WILL ACCEPT RESPONSIBILITY FOR ANY STORM WATER RUNOFF...
14. THE NEIGHBORHOOD DECLARATION AND MASTER DECLARATION SET FORTH THE TERMS AND RESTRICTIONS FOR NIGHTLY RENTALS AND LEASING OF LOTS IN THE PROJECT...
15. ACCESS TO THE PROJECT IS BY WAY OF A STATE HIGHWAY MAINTAINED BY THE UTAH DEPARTMENT OF TRANSPORTATION...
16. THIS PLAT DOES NOT AMEND ANY WEBER COUNTY ORDINANCES. IN THE EVENT OF A CONFLICT BETWEEN THIS PLAT AND WEBER COUNTY ORDINANCES, THE WEBER COUNTY ORDINANCES SHALL CONTROL...
17. VILLAGE NESTS RETREAT AT POWDER MOUNTAIN IS LOCATED WITHIN A NATURAL HAZARDS SPECIAL STUDY AREA AS SHOWN ON THE NATURAL HAZARDS MAP...
18. THIS PLAT VACATES AND REPLACES THE ENTIRE VILLAGE NESTS RETREAT AT POWDER MOUNTAIN SUBDIVISION, AS RECORDED IN THE OFFICE OF THE WEBER COUNTY RECORDER...

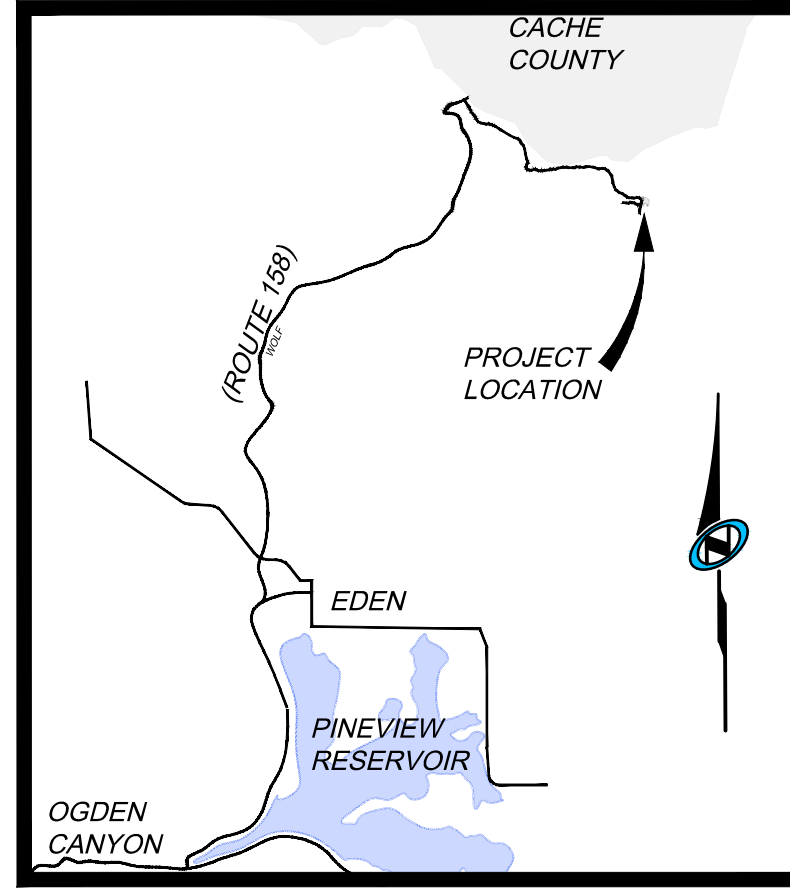

Vicinity Map
N.T.S.

OWNER'S DEDICATION:

SHHG PMDP PHASE II, LLC ("DECLARANT"), AS THE OWNER OF THE HEREIN DESCRIBED TRACT OF LAND, DOES HEREBY SET APART AND SUBDIVIDE THE SAME INTO LOTS AND PARCELS AS SHOWN HEREON, SUBJECT TO ALL OF THE RESTRICTIONS, RIGHTS AND LIMITATIONS SET FORTH IN THE PLAT NOTES, AND NAME SAID TRACT, TO BE KNOWN AS VILLAGE NEST RETREAT POWDER MOUNTAIN, AND DOES HEREBY:

- 1. PRIVATE STREETS, ACCESS, RIGHTS-OF-WAY. DEDICATE AND RESERVE UNTO DECLARANT, ITS HEIRS, GRANTEEES AND ASSIGNS, AND SUMMIT MOUNTAIN HOLDING GROUP, L.L.C., AS MASTER DEVELOPER A RIGHT-OF-WAY TO BE USED IN COMMON WITH ALL OTHERS WITHIN SAID SUBDIVISION...
2. PUBLIC UTILITY AND DRAINAGE EASEMENTS. GRANT AND DEDICATE A PERPETUAL RIGHT AND EASEMENT OVER, UPON AND UNDER THE LANDS DESIGNATED AS PUBLIC UTILITY, STORM WATER DETENTION PONDS AND DRAINAGE EASEMENTS...
3. PRIVATE EASEMENTS. GRANT AND DEDICATE THOSE CERTAIN EASEMENTS DESCRIBED IN NOTES 6, AND 10 OF THIS PLAT...
4. OPEN SPACES. GRANT AND DEDICATE TO WEBER COUNTY A PERPETUAL OPEN SPACE RIGHT AND EASEMENT ON AND OVER THE OPEN SPACE PARCELS FOR THE LIMITED PURPOSE OF GUARANTEEING TO WEBER COUNTY THAT THE OPEN SPACE PARCELS REMAIN OPEN AND UNDEVELOPED EXCEPT FOR APPROVED RECREATIONAL, PARKING AND OPEN SPACE PURPOSES...

IN WITNESS WHEREOF, DECLARANT HAS EXECUTED THIS OWNER'S DEDICATION AS OF THE _____ DAY OF _____, 20____

SHHG PMDP PHASE II LLC, A UTAH LIMITED LIABILITY COMPANY
BY: SHHG PHASE II INVESTOR LLC, A DELAWARE LIMITED LIABILITY COMPANY
ITS: MANAGING MEMBER
BY: SHHG INVESTMENTS LLC, A DELAWARE LIMITED LIABILITY COMPANY
ITS: SOLE MEMBER
NAME: _____
TITLE: _____

ACKNOWLEDGEMENT:

STATE OF UTAH }
COUNTY OF _____ } SS.
ON THIS ____ DAY OF _____, 20____, BEFORE ME _____, A NOTARY PUBLIC, PERSONALLY APPEARED _____ AS THE AUTHORIZED SIGNATORY OF SHHG INVESTMENTS LLC, A DELAWARE LIMITED LIABILITY COMPANY...
NOTARY PUBLIC SIGNATURE: _____, RESIDING IN: _____
COMMISSION #: _____, MY COMMISSION EXPIRES: _____

SURVEYOR'S CERTIFICATE

I, NATHAN CHRISTENSEN, DO HEREBY CERTIFY THAT I AM A REGISTERED PROFESSIONAL LAND SURVEYOR IN THE STATE OF UTAH IN ACCORDANCE WITH TITLE 58, CHAPTER 22, PROFESSIONAL ENGINEERS AND LAND SURVEYORS ACT, AND THAT I HAVE COMPLETED SURVEY OF THE PROPERTY DESCRIBED ON THIS PLAT IN ACCORDANCE WITH SECTION 17-23-17 AND HAVE VERIFIED ALL MEASUREMENTS AND HAVE PLACED MONUMENTS AS REPRESENTED IN THIS PLAT, AND THAT THIS PLAT VILLAGE NEST RETREAT AT POWDER MOUNTAIN, IN WEBER COUNTY, UTAH, HAS BEEN DRAWN CORRECTLY TO THE DESIGNATED SCALE AND IS A TRUE AND CORRECT REPRESENTATION OF THE HEREON DESCRIBED LANDS INCLUDING SAID SUBDIVISION, BASED UPON DATA COMPILED FROM RECORDS IN THE WEBER COUNTY RECORDER'S OFFICE AND FROM SAID SURVEY MADE BY ME ON THE GROUND. I FURTHER CERTIFY THAT THE REQUIREMENTS OF ALL APPLICABLE STATUTES AND ORDINANCES OF WEBER COUNTY CONCERNING ZONING REQUIREMENTS REGARDING LOT MEASUREMENTS HAVE BEEN COMPLIED WITH.

NATHAN CHRISTENSEN
PROFESSIONAL LAND SURVEYOR
UTAH CERTIFICATE NO. 10175991

LEGAL DESCRIPTION

BEGINNING AT A POINT ON THE SOUTHERLY RIGHT-OF-WAY LINE OF MERIDIAN AVENUE, SAID POINT ALSO BEING ON THE NORTHEASTERLY BOUNDARY OF SUMMIT EDEN PHASE I/D AMENDMENT 1, AS RECORDED IN THE OFFICE OF THE WEBER COUNTY RECORDER, SAID POINT ALSO LIES NORTH 87°49'14" EAST 1,550.74 FEET ALONG THE SECTION LINE AND SOUTH 605.24 FEET, FROM THE NORTH QUARTER CORNER OF SECTION 8, TOWNSHIP 7 NORTH, RANGE 2 EAST, SALT LAKE BASE AND MERIDIAN (BASIS OF BEARINGS FOR THIS DESCRIPTION IS NORTH 89°55'51" WEST ALONG THE LINE BETWEEN THE NORTHWEST CORNER OF SECTION 6, TOWNSHIP 7 NORTH, RANGE 2 EAST, SALT LAKE BASE AND MERIDIAN AND THE MONUMENT AT THE INTERSECTION OF THE WEBER/CACHE COUNTY LINE, THE FROM THE NORTHWEST CORNER OF SECTION 6 TO THE NORTH QUARTER CORNER OF SECTION 8 IS SOUTH 53°43'38" EAST 9312.68 FEET); THENCE ALONG SAID ROW LINE FOLLOWING 2 COURSES: 1) NORTHEASTERLY ALONG A 339.04 FOOT RADIUS CURVE TO THE RIGHT, (CHORD BEARS NORTH 58°46'38" EAST 167.58 FEET), THOUGH A CENTRAL ANGLE OF 28°37'00", FOR AN ARC DISTANCE OF 169.34 FEET; 2) THENCE NORTH 72°35'08" EAST 125.36 FEET; THENCE SOUTH 17°24'52" EAST 463.50 FEET; THENCE SOUTH 23°17'35" WEST 140.62 FEET; THENCE SOUTH 18°14'18" WEST 100.94 FEET; THENCE WEST 58.61 FEET, TO A POINT ON THE EASTERLY RIGHT-OF-WAY LINE OF DAYBREAK RIDGE; THENCE NORTH 30°01'02" WEST, ALONG SAID EASTERLY LINE 126.68 FEET TO A POINT OF CURVATURE; THENCE NORTHERLY ALONG A 307.00 FOOT RADIUS CURVE TO THE RIGHT, ALONG SAID EASTERLY LINE, (CHORD BEARS NORTH 17°51'53" WEST A DISTANCE OF 124.26 FEET), THROUGH A CENTRAL ANGLE OF 24°18'18", A DISTANCE OF 130.23 FEET; THENCE NORTH 05°42'44" WEST ALONG SAID EASTERLY LINE 87.37 FEET; THENCE NORTHWESTERLY ALONG A 118.00 FOOT RADIUS CURVE TO THE LEFT, ALONG SAID EASTERLY LINE, (CHORD BEARS NORTH 29°46'51" WEST A DISTANCE OF 36.25 FEET), THROUGH A CENTRAL ANGLE OF 48°28'14", A DISTANCE OF 49.14 FEET; THENCE NORTH 53°50'54" WEST ALONG SAID EASTERLY LINE 46.43 FEET; THENCE NORTHWESTERLY ALONG A 232.00 FOOT RADIUS CURVE TO THE RIGHT, ALONG SAID EASTERLY LINE, (CHORD BEARS NORTH 49°56'25" WEST A DISTANCE OF 31.63 FEET), THROUGH A CENTRAL ANGLE OF 07°49'07", A DISTANCE OF 31.66 FEET; THENCE NORTH 46°01'51" WEST ALONG SAID EASTERLY LINE 64.33 FEET; THENCE NORTHEASTERLY ALONG A 23.00 FOOT RADIUS CURVE TO THE RIGHT, ALONG SAID EASTERLY LINE, (CHORD BEARS NORTH 07°01'51" WEST A DISTANCE OF 32.53 FEET), THROUGH A CENTRAL ANGLE OF 00°00'00", A DISTANCE OF 36.13 FEET TO THE SOUTHERLY LINE OF MERIDIAN AVENUE; THENCE NORTH 43°58'09" EAST ALONG SAID SOUTHERLY LINE 18.79 FEET TO THE POINT OF BEGINNING.

CONTAINING: 142,306 S.F. OR 3.267 ACRES

SURVEY NARRATIVE:

- 1) THE PURPOSE FOR THIS SURVEY AND PLAT IS TO AMEND THE ENTIRE VILLAGE NESTS EAST AT POWDER MOUNTAIN PRUD, AS RECORDED IN THE OFFICE OF THE WEBER COUNTY RECORDER IN BOOK 81, AT PAGE 68, 69, ENTRY NO. 2871994, WHICH REPLACE AND VACATE THE ENTIRETY VILLAGE NESTS AT POWDER MOUNTAIN CONDOMINIUM PLAT, AS RECORDED IN THE OFFICE OF THE WEBER COUNTY RECORDER IN BOOK 78, AT PAGE 80, ENTRY NO. 2777000.
2) THE BASIS OF BEARINGS FOR THIS PLAT IS NORTH 89°55'51" WEST BETWEEN THE NORTHEAST CORNER OF SECTION 1, TOWNSHIP 7 NORTH, RANGE 1 EAST, SALT LAKE BASE AND MERIDIAN AND A FOUND WEBER COUNTY LINE MONUMENT SET BY THE WEBER COUNTY SURVEYOR'S OFFICE. THIS BASIS DIFFERS FROM WEBER COUNTY SURVEYORS BASIS BY 00°00'14" AS SHOWN ON COUNTY LINE DECLARATION RECORDED PLAT BOOK 74, PAGE 64.
3) THE WESTERLY AND NORTHERLY BOUNDARY LINE WAS SET BY THE EASTERLY LINE OF DAYBREAK RIDGE, AND THE SOUTHERLY LINE OF MERIDIAN AVENUE, AS RECORDED IN SUMMIT EDEN PHASE I/D, AMENDMENT 1, AND THE OVERLOOK AT POWDER MOUNTAIN PHASE I/D, WHICH WAS DETERMINED FROM THE FOUND CENTERLINE MONUMENT IN SUMMIT PASS AND THE FOUND SECTION CORNERS AS STATED ON THE RECORDED PLAT. THE EASTERLY AND SOUTHERLY LINE IS A PROPOSED LOCATION DETERMINED BY THE LAND OWNER.

Table with 6 columns: WEBER COUNTY ATTORNEY, WEBER COUNTY SURVEYOR, WEBER COUNTY ENGINEER, WEBER COUNTY PLANNING COMMISSION APPROVAL, WEBER COUNTY COMMISSION ACCEPTANCE, POWDER MOUNTAIN WATER AND SEWER DISTRICT. Each column contains a signature line and a brief statement of approval or certification.

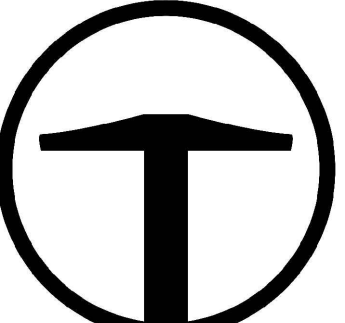

TALISMAN CIVIL CONSULTANTS
5217 SOUTH STATE STREET
SUITE 200
MURRAY, UT 84107
801.743.1300

RECORDED #

STATE OF UTAH, COUNTY OF WEBER, RECORDED AND FILED AT THE
REQUEST OF: _____
ENTRY NO: _____
DATE: _____ TIME: _____
BOOK: _____ PAGE: _____
FEE \$ _____
WEBER COUNTY RECORDER

Exhibit A

VILLAGE NESTS RETREAT AT POWDER MOUNTAIN AMENDING VILLAGE NESTS EAST AT POWDER MOUNTAIN-PRUD

LOCATED IN THE NORTHEAST QUARTER OF SECTION 8,
TOWNSHIP 7 NORTH, RANGE 2 EAST,
SALT LAKE BASE AND MERIDIAN, WEBER COUNTY
SEPTEMBER 2023

NORTHWEST CORNER SECTION 6,
TOWNSHIP 7 NORTH, RANGE 2 EAST
SALT LAKE BASE AND MERIDIAN
FOUND GLO 1944, 4" BRASS CAP,
GOOD CONDITION
DETAIL "B"

BASIS OF BEARINGS
N 89°55'51" W 1381.07'
(N 89°56'05" W 1380.98' RECORD
STATE PLANE GRID PER
WEBER COUNTY SURVEY
OFFICE)

NORTH QUARTER
CORNER SECTION 8,
TOWNSHIP 7 NORTH,
RANGE 2 EAST
SALT LAKE BASE AND
MERIDIAN FOUND 1944
GLO BRASS CAP,
GOOD CONDITION
DETAIL "A"

NORTHEAST CORNER SECTION
8, TOWNSHIP 7 NORTH,
RANGE 2 EAST
SALT LAKE BASE AND
MERIDIAN (CALCULATED)

WEBER COUNTY
SURVEY MONUMENT PER
WEBER COUNTY
RECORD FOR 2013
CONDITION
DETAIL "A"

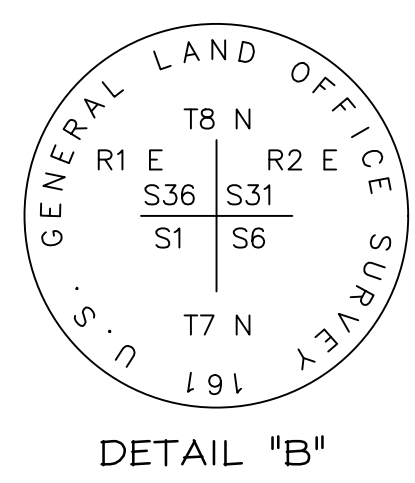
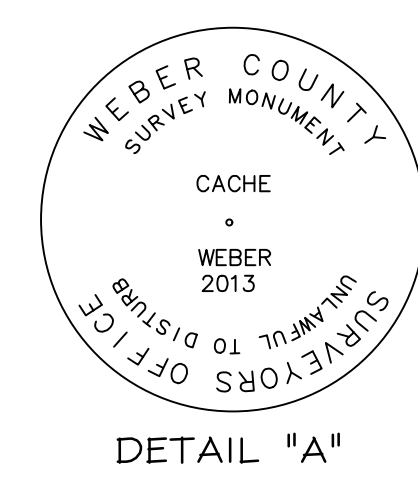

DETAIL "A"

DETAIL "B"

CURVE TABLE					
CURVE	RADIUS	LENGTH	DELTA	BEARING	CHORD
C1	100.64	32.01	18°12'53"	N49°51'42"E	31.88
C2	250.00	9.21	2°06'41"	S47°05'12"E	9.21
C3	90.00	137.15	87°18'37"	S77°22'33"E	124.26
C4	250.00	24.90	5°42'26"	S50°59'46"E	24.89
C5	212.00	103.63	28°00'30"	S19°42'59"E	102.60
C6	100.00	84.02	48°08'14"	S29°46'51"E	81.57
C7	213.00	50.89	13°41'22"	S12°33'25"E	50.77
C8	69.90	16.26	13°19'50"	N26°04'01"W	16.23
C9	23.50	28.30	69°00'07"	S80°31'55"E	26.62
C10	23.50	2.46	5°59'53"	N61°58'05"E	2.46
C11	325.00	137.86	24°18'18"	S17°51'53"E	136.83
C12	108.00	9.21	4°53'16"	N61°24'47"E	9.21
C13	108.00	39.68	21°03'04"	N74°22'57"E	39.46
C14	108.00	33.95	18°00'31"	S86°05'16"E	33.81
C15	108.00	36.97	19°36'56"	S67°16'32"E	36.79
C16	108.00	34.19	18°08'09"	S48°24'00"E	34.04
C17	108.00	10.58	5°36'41"	S36°31'35"E	10.57
C18	230.00	8.44	2°06'12"	S32°40'08"E	8.44
C19	230.00	40.90	10°11'23"	S26°31'20"E	40.85
C20	230.00	38.04	9°28'35"	S16°41'22"E	38.00
C21	230.00	25.04	6°14'20"	S08°49'54"E	25.03
C22	195.00	8.90	2°36'53"	S07°01'11"E	8.90
C23	195.00	37.69	11°04'28"	S13°51'52"E	37.63
C24	23.50	4.21	10°16'04"	S24°32'08"E	4.21
C25	23.50	24.31	59°16'29"	S59°18'25"E	23.24
C26	52.50	267.95	292°25'27"	S57°16'04"W	58.39
C27	23.50	8.65	21°04'53"	N12°56'21"E	8.60
C28	23.50	10.74	26°11'32"	N10°41'51"W	10.65
C29	231.00	29.85	7°24'11"	N20°05'32"W	29.83
C30	231.00	40.28	9°59'26"	N11°23'43"W	40.23
C31	231.00	2.77	0°41'16"	N06°03'22"W	2.77
C32	194.00	38.25	11°17'43"	N11°21'36"W	38.18
C33	194.00	56.59	16°42'47"	N25°21'51"W	56.39
C34	72.00	29.88	23°46'33"	N45°36'31"W	29.66
C35	72.00	79.84	63°32'04"	N89°15'49"W	75.81
C36	20.50	40.37	112°49'07"	S02°33'35"W	34.15
C37	183.00	278.87	87°18'37"	S77°22'33"E	252.66
C38	305.00	149.10	28°00'30"	S19°42'59"E	147.62

LINE TABLE		
LINE	LENGTH	BEARING
L1	21.29	N40°45'16"E
L2	3.51	N58°58'09"E
L3	20.98	S33°43'14"E
L4	87.37	S5°42'44"E
L5	19.89	N53°50'59"W
L6	56.62	N32°43'56"W
L7	26.68	N58°58'09"E
L8	28.49	N58°58'09"E
L9	34.79	N46°01'51"W
L10	20.98	S33°43'14"E
L11	3.51	S58°58'09"E
L13	14.80	N13°36'54"E
L14	4.19	N58°36'54"E

LEGEND

- BOUNDARY LINE
- LOT LINE
- SECTION LINE
- EASEMENT LINE
- ADJOINER DEED LINES
- CALCULATED SECTION CORNER AS NOTED
- SECTION CORNER AS NOTED
- STREET MONUMENT
- SET REBAR WITH PLASTIC CAP STAMPED "TALISMAN CIVIL"

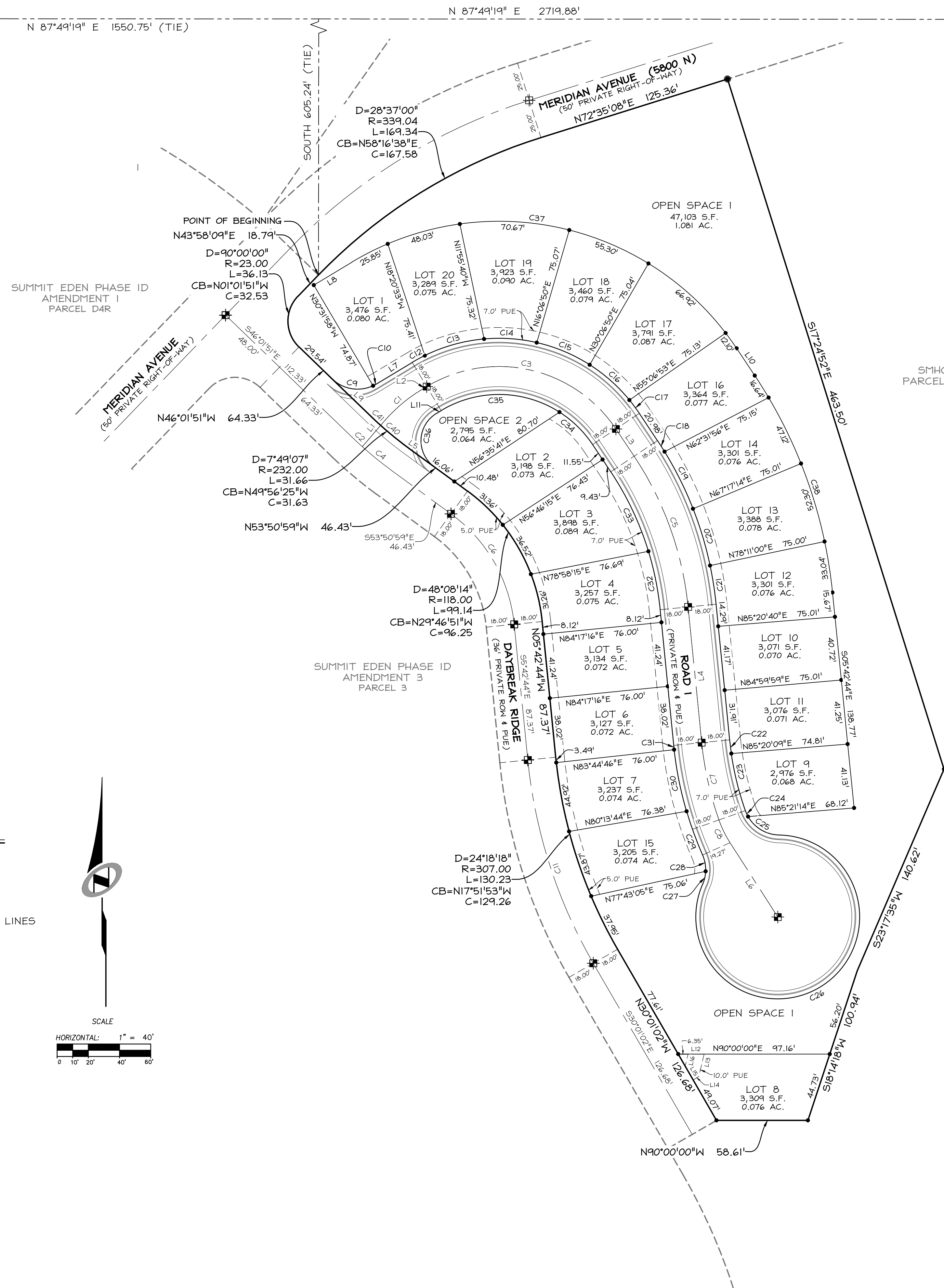
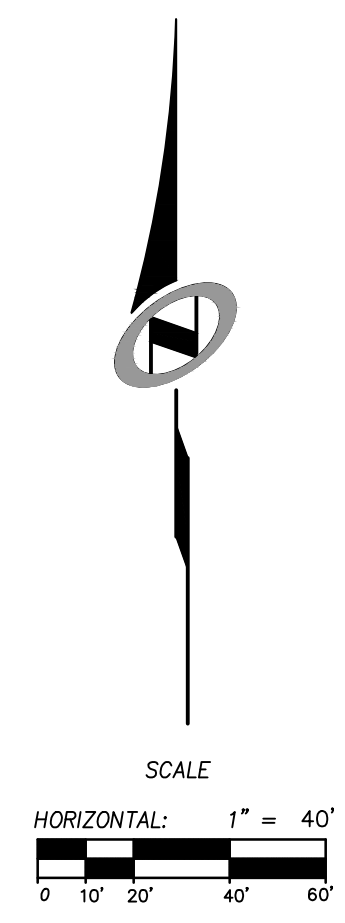

SMHG LANDCO LLC
PARCEL NO. 23-012-0186

SMHG PHASE I, LLC.
3632 N. WOLF CREEK DR.
EDEN, UT, 84310

Sheet 2 of 2

TALISMAN
CIVIL CONSULTANTS

5217 SOUTH STATE STREET
SUITE 200
MURRAY, UT 84107
801.743.1500

RECORDED #

STATE OF UTAH, COUNTY OF WEBER,
RECORDED AND FILED AT THE

REQUEST OF: _____

ENTRY NO: _____

DATE: _____ TIME: _____

BOOK: _____ PAGE: _____

FEE \$ _____

WEBER COUNTY RECORDER



Staff Report to the Ogden Valley Planning Commission

Weber County Planning Division

Synopsis

Application Information

Application Request:	File No. CUP2023-12: Request for approval of a conditional use permit for a public utility substation for the Osprey sewer lift station located at approximately 1900 N Highway 158, Eden, UT, 84310.
Application Type:	Administrative
Applicant:	Osprey Ranch LLC
Approximate Address:	1900 N Highway 158, Eden, UT, 84310.
Project Area:	12,560 Square feet
Zoning:	FV-3
Existing Land Use:	Vacant
Proposed Land Use:	Public Utility Substation
Parcel ID:	20-193-0032
Township, Range, Section:	Township 6 North, Range 1 East, Section 03 NW

Adjacent Land Use

North:	Residential	South:	Residential
East:	Hwy 158	West:	Vacant Residential

Staff Information

Report Presenter:	Tammy Aydelotte taydelotte@webercountyutah.gov 801-399-8794
Report Reviewer:	SB

Applicable Ordinances

- Weber County Land Use Code Title 104 Chapter 14 (FV-3 Zone)
- Weber County Land Use Code Title 108 Chapter 4 (Conditional Uses)
- Weber County Land Use Code Title 108 Chapter 10 (Public Utility Substations)
- Weber County Land Use Code Title 108 Chapter 2 (Ogden Valley Architectural, Landscape, and Screening Standards)
- Weber County Land Use Code Title 108 Chapter 1 (Design Review)

Background and Summary

Applicant is requesting a conditional use permit for a sewer lift station for Osprey Ranch Subdivision, to service Osprey Ranch subdivision, a proposed 61-lot subdivision. This proposed lift station will provide sewer services to two phases of Osprey Ranch Subdivision (Phase 2 is currently under subdivision review), and will be owned, operated, and maintained by Wolf Creek Water and Sewer Improvement District. The lift station is considered a public utility substation.

The application is being processed as an administrative review due to the approval procedures in Uniform Land Use Code of Weber County, Utah (LUC) §108-1-2 which requires the planning commission to review and approve applications for conditional use permits and design reviews.

Analysis

General Plan: As a conditional use, this operation is allowed in the FV-3 Zone. With the establishment of appropriate conditions as determined by the land use authority, this operation will not negatively impact any of the goals and policies of the General Plan.

Zoning: The subject property is located within the FV-3 zone. The purpose and intent of the FV-3 zone are described in LUC 104-14-1:

The purpose of the Forest Valley Zone, FV-3 is to provide area for residential development in a forest setting at a low density, as well as to protect as much as possible the naturalistic environment of the development.

The FV-3 zone allows the proposed use, as a conditional use. The proposed site plan indicates that the lift station meets the minimum setbacks for a public utility substation in the FV-3 zone (30' front, 20' rear, 20' feet from the south side lot line, 20 feet from the north lot line).

Under the LUC 108-10, there is not minimum lot area for public utility substations. The proposed improvements will be located on a site of approximately 12,560 square feet.

Conditional Use Review: A review process has been outlined in LUC §108-4-3 to ensure compliance with the applicable ordinances and to mitigate anticipated detrimental effects. The applicant has received approval from the County Engineering Division and the Weber Fire District for the proposal.

The following is an analysis of the proposal reviewed against the conditional use standards:

(1) Standards relating to safety for persons and property. The proposal is not anticipated or expected to negatively impact this property, surrounding properties, or persons. The applicant plans to re-seed any areas disturbed by construction in order to maintain the native vegetation.

(2) Standards relating to infrastructure, amenities, and services: The proposal is not anticipated or expected to negatively impact any existing infrastructure, amenities, or services in the area.

(3) Standards relating to the environment. The proposal is not anticipated or expected to negatively impact the environment.

(4) Standards relating to the current qualities and characteristics of the surrounding area and compliance with the intent of the general plan. The proposal is not anticipated to negatively impact the surrounding area, nor is it contrary to the recommendations of the general plan.

Design Review: The proposed conditional use mandates a design review as outlined in LUC §108-1 to ensure that the general design, layout and appearance of the building remains orderly and harmonious with the surrounding neighborhood. The matters for consideration are as follows:

Considerations relating to traffic safety and traffic congestion. The proposal includes a site plan that identifies an access to the pump house off of a proposed new road in phase two of the proposed Osprey Ranch Subdivision. Neither traffic safety hazards nor traffic congestion are anticipated given the minimal site visitations to the substations.

Considerations relating to landscaping. The applicant is proposing a gravel landscaping area immediately surrounding the proposed structures, and 7,536 area of hydro seed with a native seed mix (60% of overall site area) (108-2).

Considerations relating to buildings and site layout. The applicant has indicated the lift station will be located in an enclosed structure consisting of CMU. Per Weber County LUC 108-2-4, "...street sides of buildings shall be constructed of non-reflective materials and shall be textured concrete, brick, stone and/or natural wood/wood-like materials. Concrete masonry units or block CMUs shall not be considered acceptable materials unless it is specially colored and textured to give an appearance of natural rough stone. Vinyl and/or aluminum siding shall not be acceptable." *"Color.* External surfaces shall be predominantly natural, muted earth tones. White may only be used as an accent color. The roof of an addition to an existing structure, when matching existing colors, shall be exempt." "Exposed metal shall be painted, stained, or anodized in permitted colors and shall be non-reflective. Copper, brass and wrought iron may remain untreated and allowed to develop a natural patina."

Applicant shall provide more detail on colors and materials, which are compliant with the above requirements, when submitting for a building permit.

Review Agencies: Weber Fire District has approved this application. Weber County Engineering has not yet reviewed this application, and a conditional use permit will not be issued until all required review agencies have their conditions met.

Staff Recommendation

Staff recommends approval of this conditional use application subject to the applicant meeting the review agency requirements and the following conditions:

1. Any outdoor lighting must meet the requirements of the Ogden Valley Outdoor Lighting Ordinance (108-16).
2. All architectural requirements shall be followed, and shown in the final engineered plans, prior to issuance of a building conditional use permit.

This recommendation is based on the following findings:

1. The proposed use is allowed in the FV-3 zone and meets the appropriate site development standards.
2. The criteria for issuance of a conditional use permit have been met because mitigation of potential detrimental effects can be accomplished.

Exhibits

- A. Building elevations and Site Plan
- B. Application and Narrative

Map 1



Exhibit A - Building Elevations and Site Plan

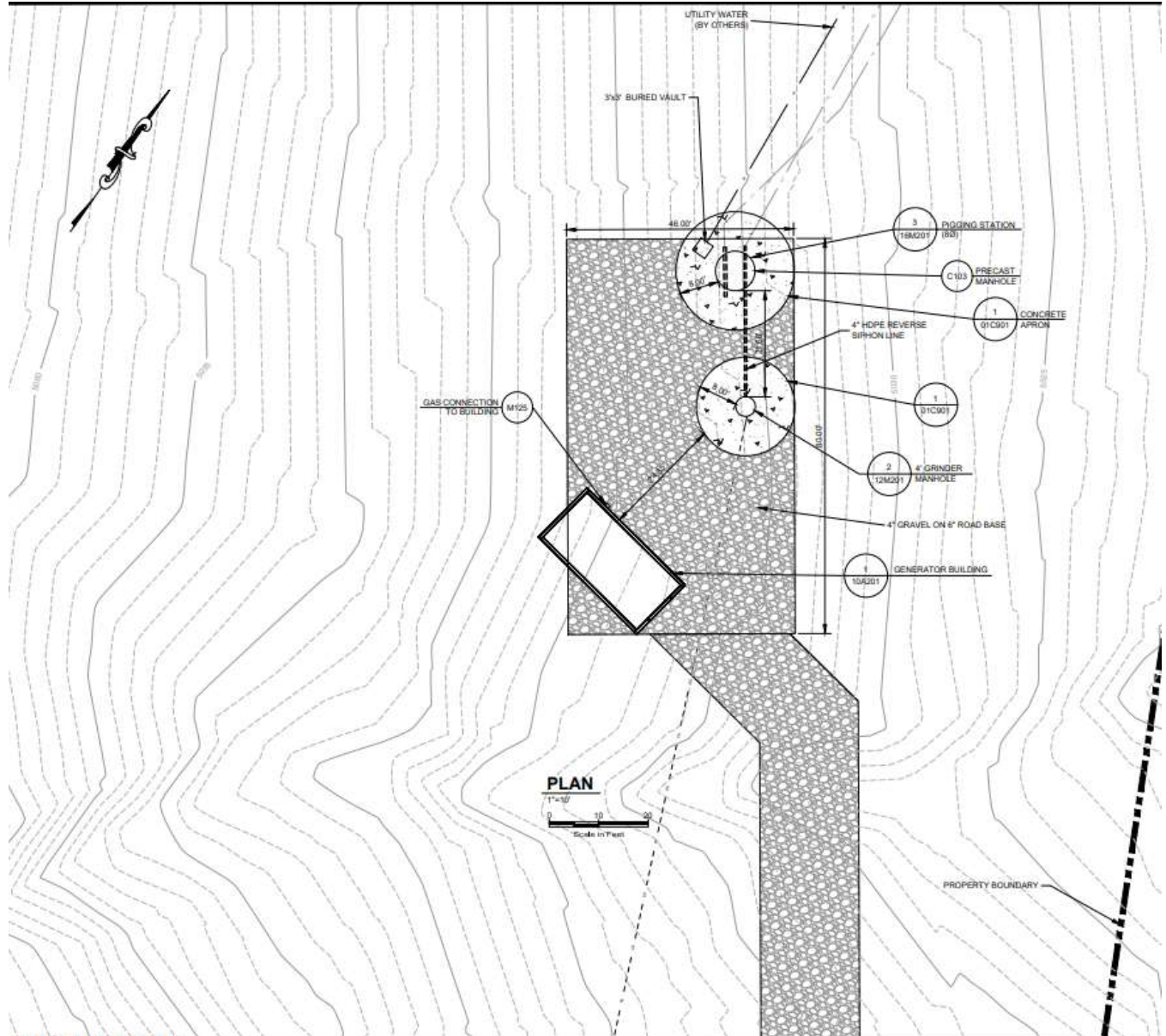

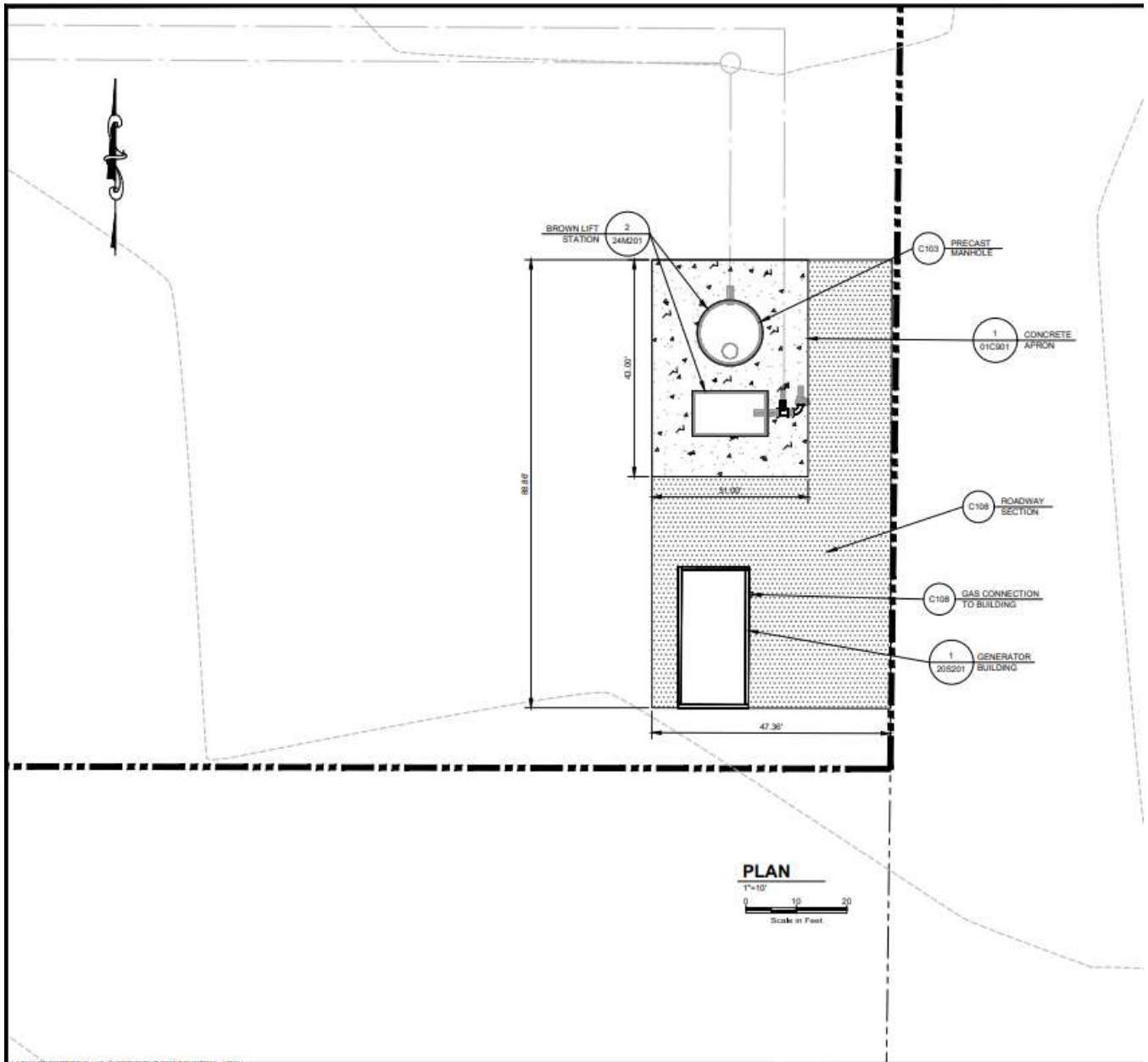

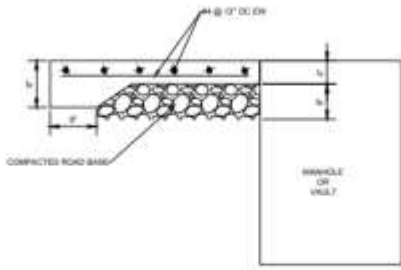



CONCRETE APRON
 12' x 12'

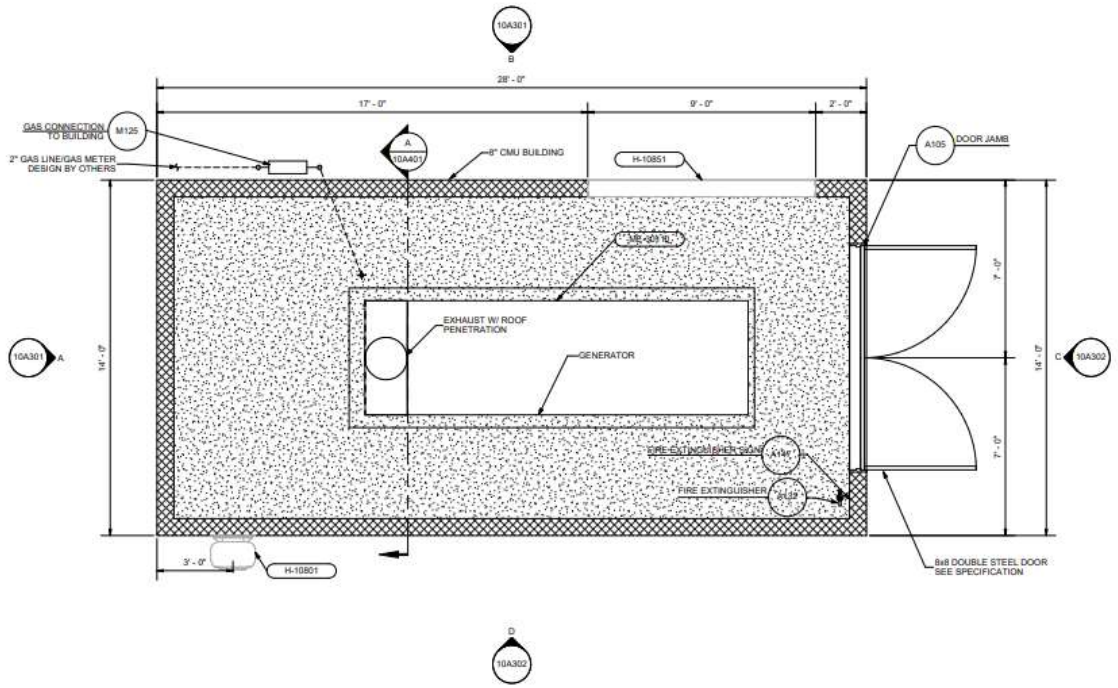

Scale: 1" = 10'



10A302
D

10A301
B

10A301
A

10A302
C

1

ARCHITECTURAL PLAN

1/2" = 1'-0"

0 2 4

Scale in Feet

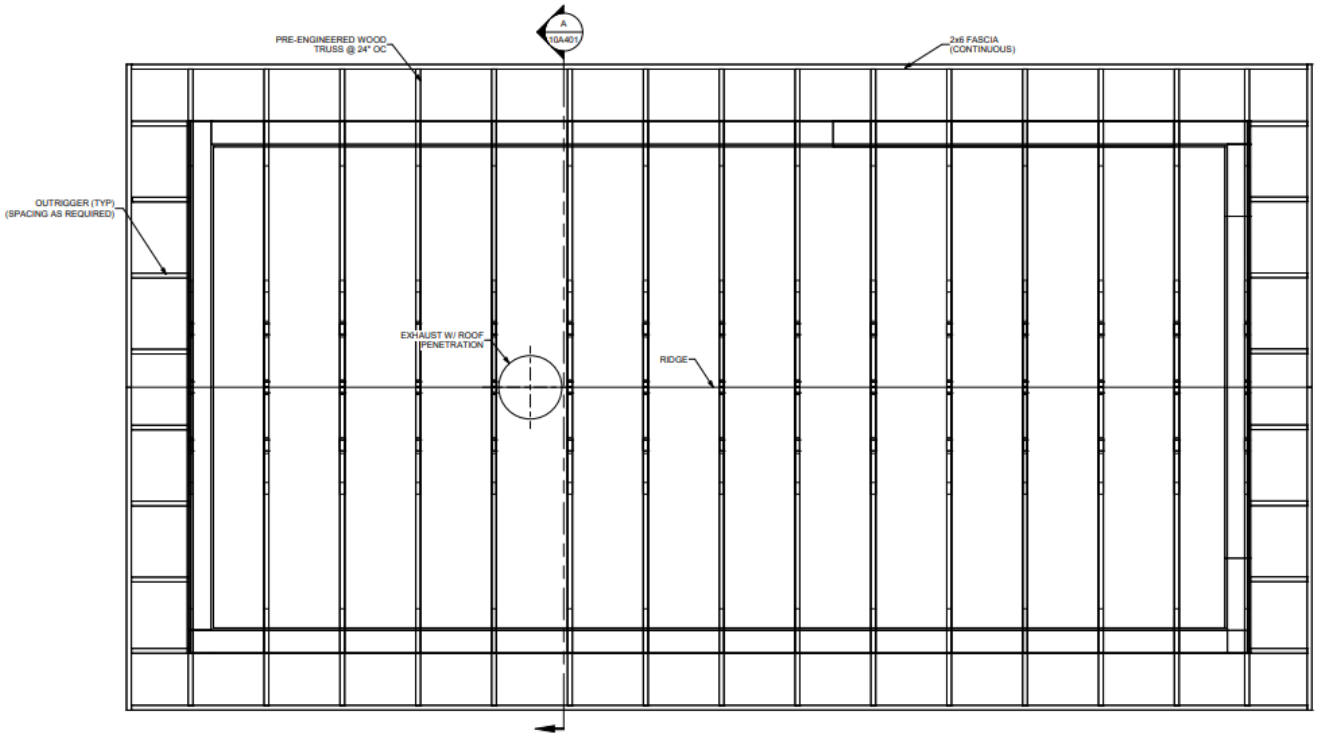

JOINT DESIGN CRITERIA

DESIGN LOAD: 20 PSF
 ROOF LIVE LOAD: 20 PSF
 ROOF SNOW LOAD: 57 PSF
 LINE LOAD DEFLECTION: L/360

TRUSSES TO BE DESIGNED BY MANUFACTURER AND SUBMITTED TO ENGINEER ON RECORD FOR APPROVAL.
 ACTUAL LOCATION AND DESIGN OF BRIDGING SHALL BE PROVIDED BY MANUFACTURER AND SUBMITTED TO ENGINEER ON RECORD PRIOR TO ERECTION OF TRUSSES.

SEE GENERAL STRUCTURAL NOTES FOR INSPECTION AND REQUIREMENTS.

ROOF PLAN



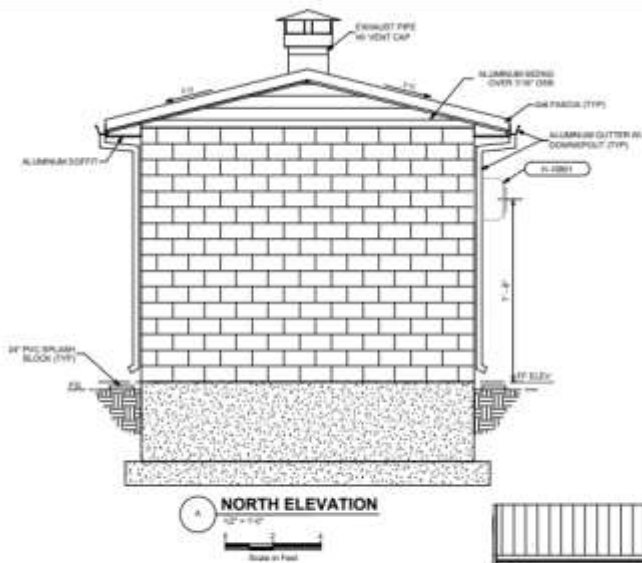

A
NORTH ELEVATION
 1/2" = 1'-0"
 Scale in Feet

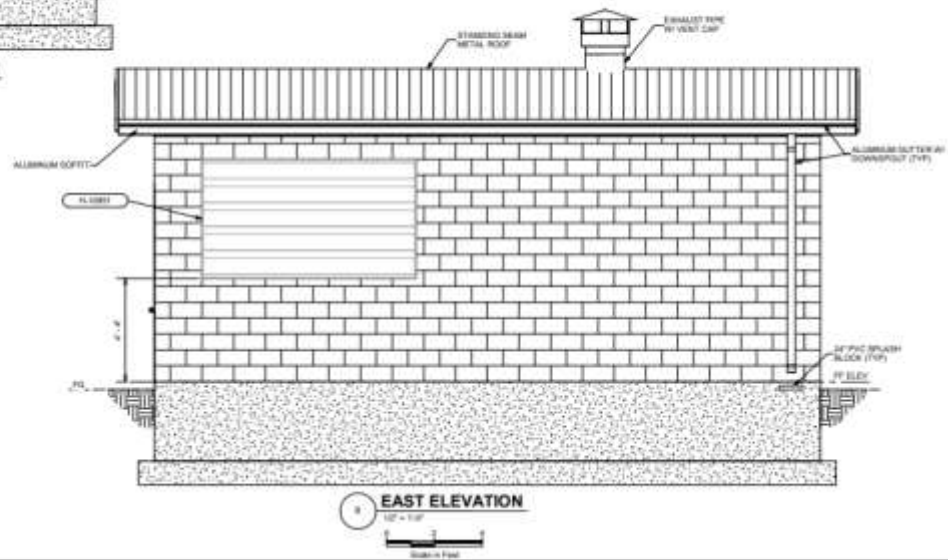

B
EAST ELEVATION
 1/2" = 1'-0"
 Scale in Feet

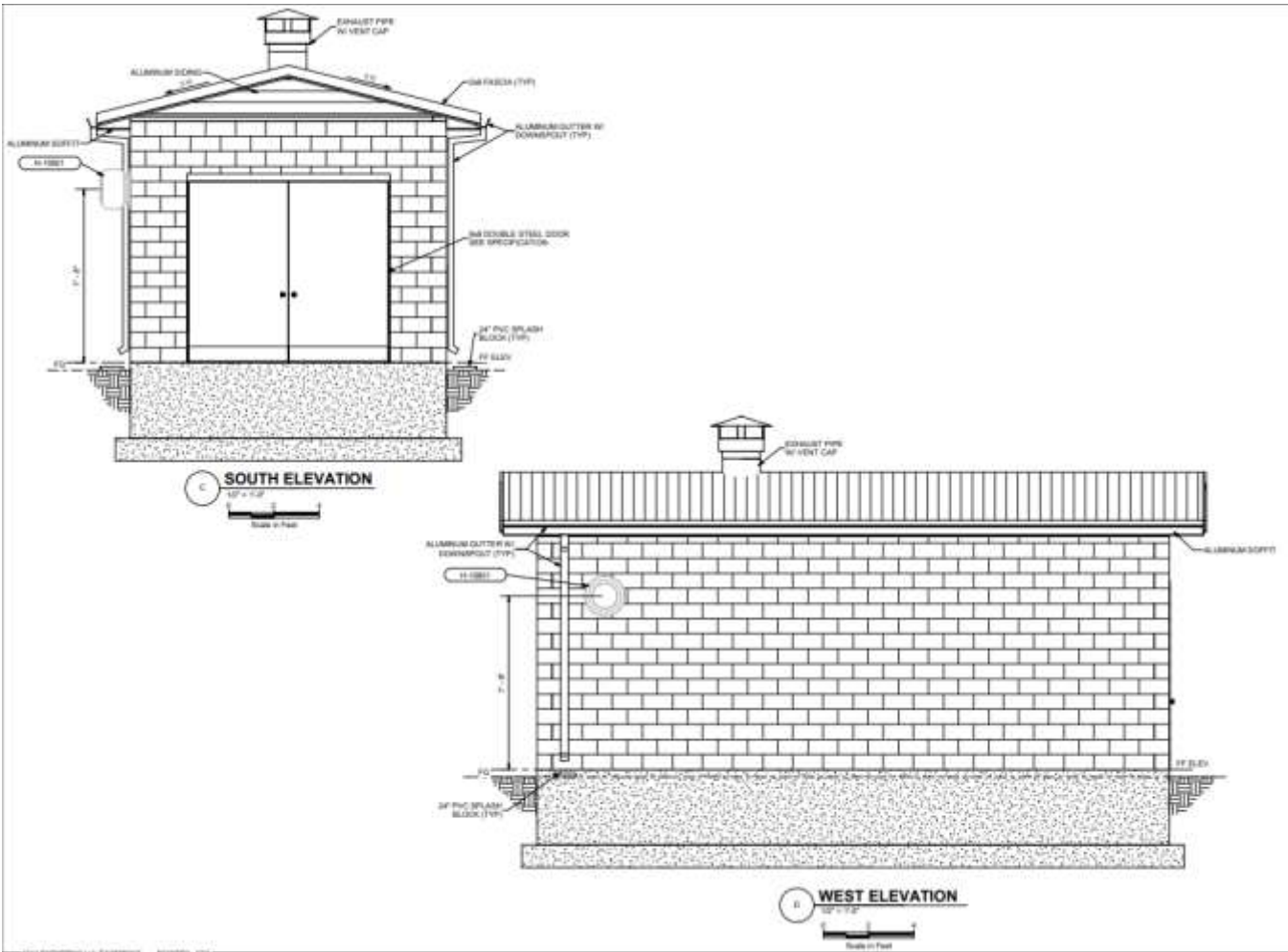

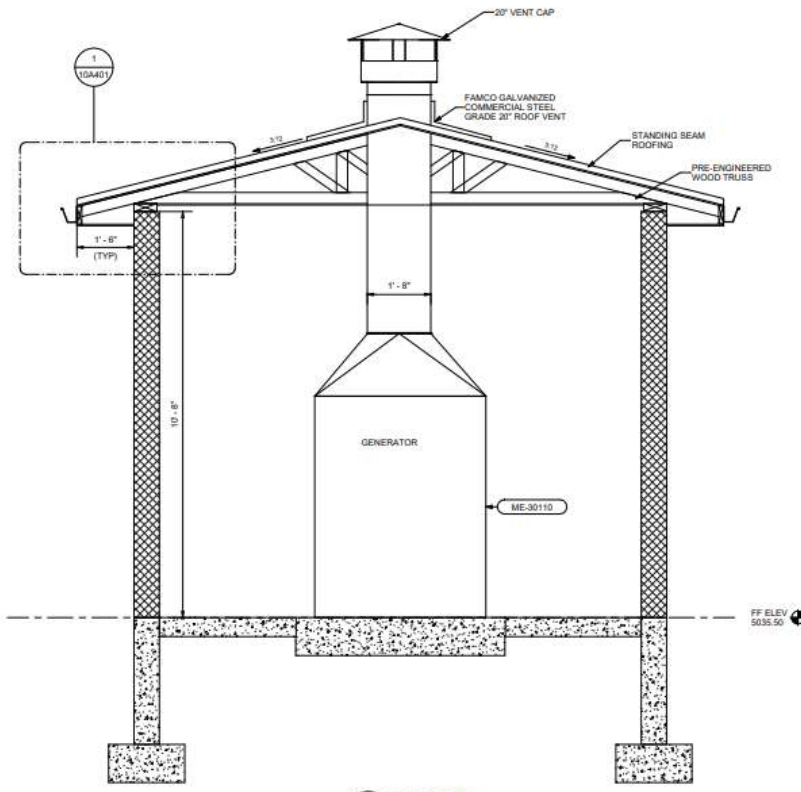

A SECTION
 10A201 3/4" = 1'-0"
 Scale in Feet

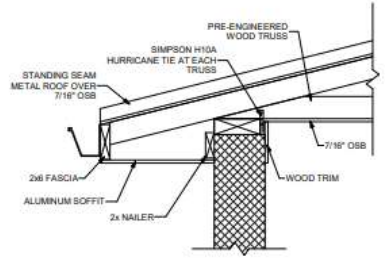

1 DETAIL
 1 1/2" = 1'-0"
 Scale in Feet

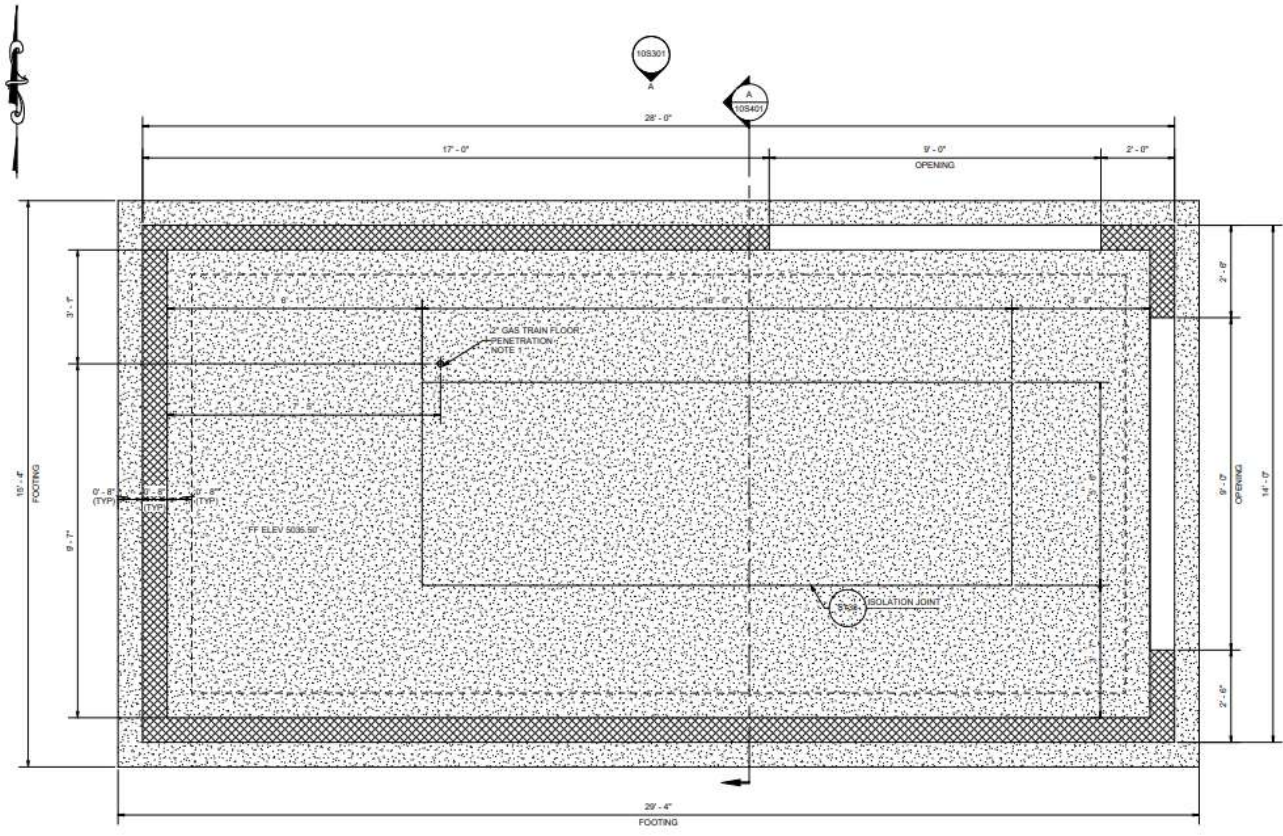

STRUCTURAL PLAN



NOTES:

1. FIELD VERIFY LOCATION CORRELATES WITH GENERATOR GAS CONNECTION LOCATION.

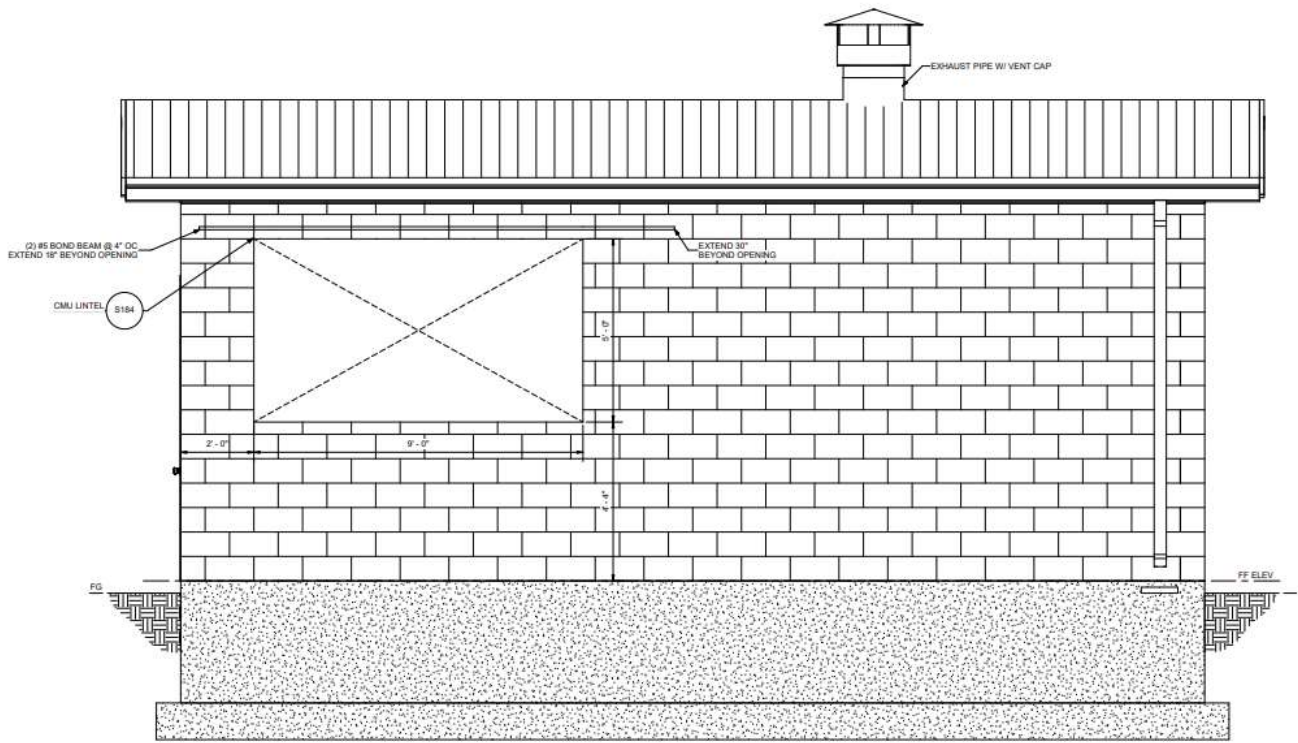

A
NORTH ELEVATION
 3/4" = 1'-0"
 Scale in Feet

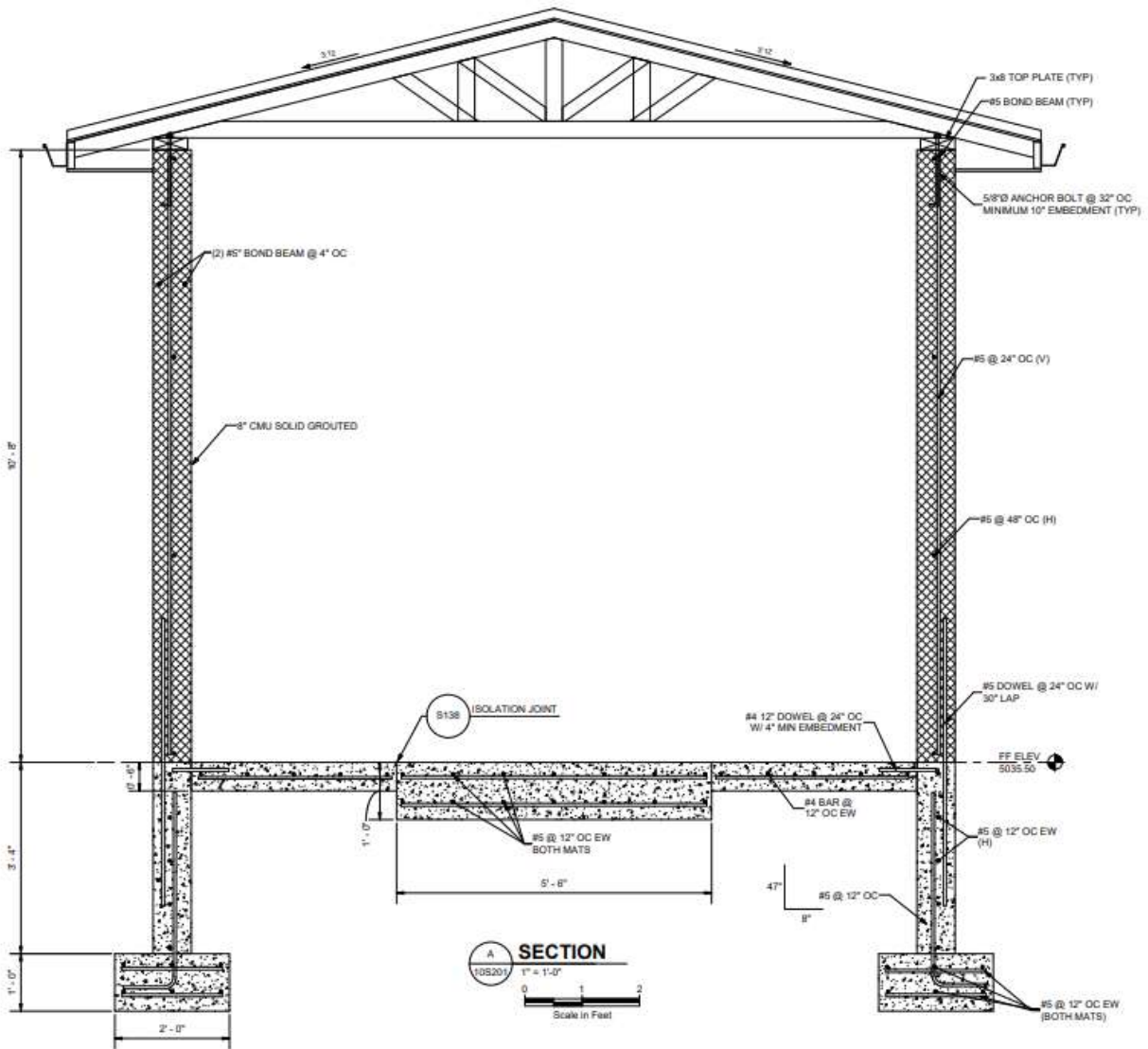

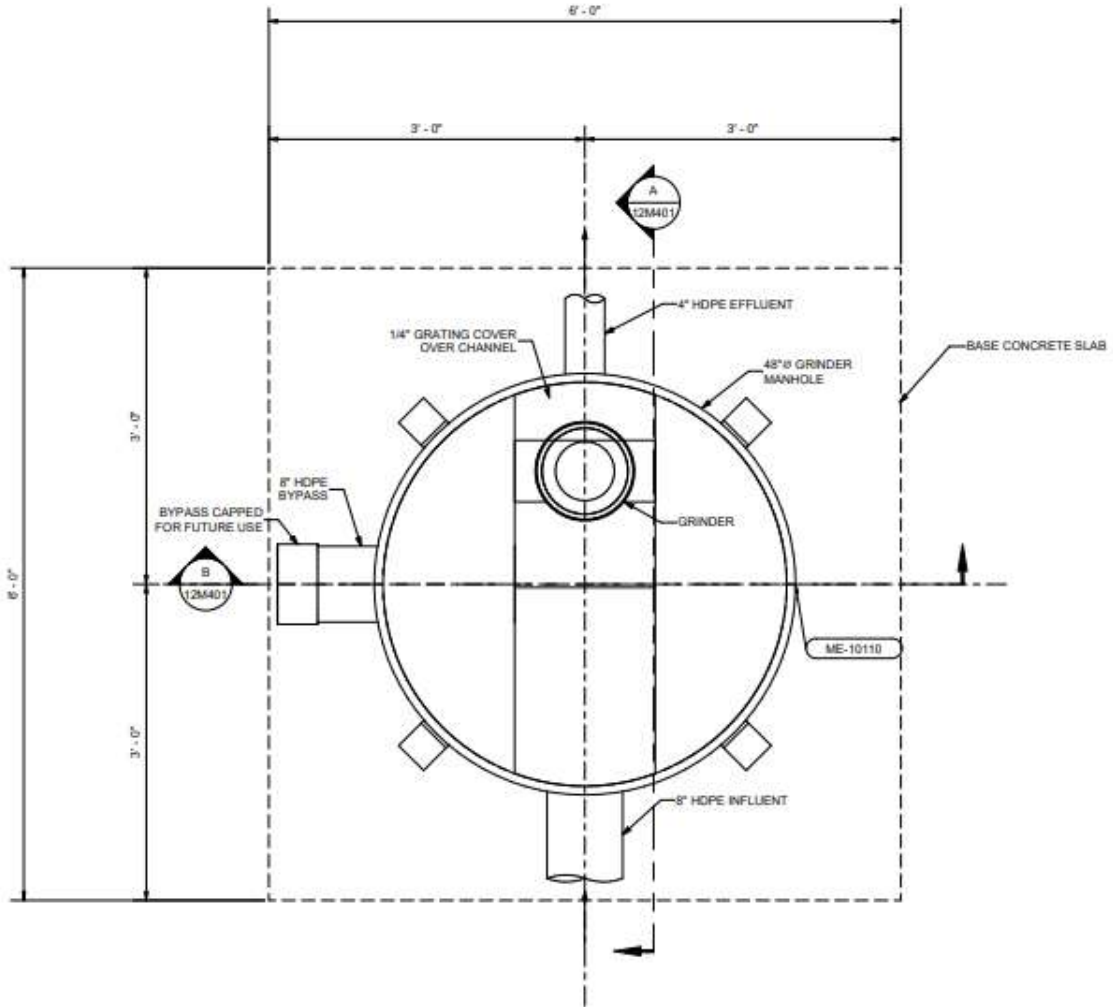

2 **MECHANICAL PLAN**
1 1/2" = 1'-0"
0 1 2
Scale in Feet

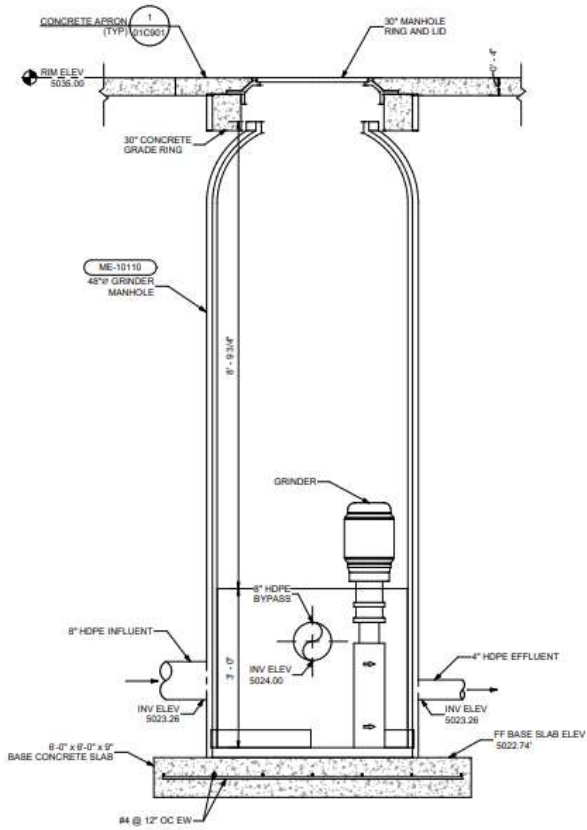

A SECTION
 12M201 1" = 1'-0"
 Scale in Feet

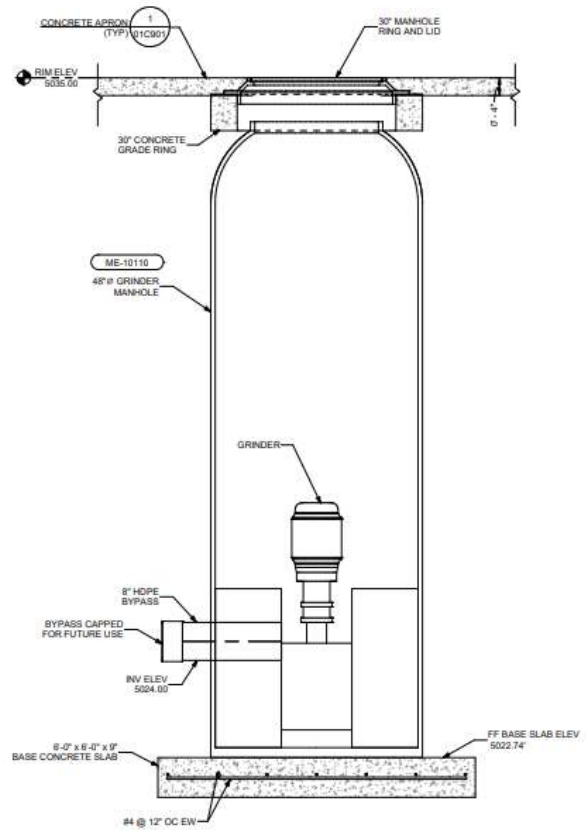

B SECTION
 12M201 1" = 1'-0"
 Scale in Feet

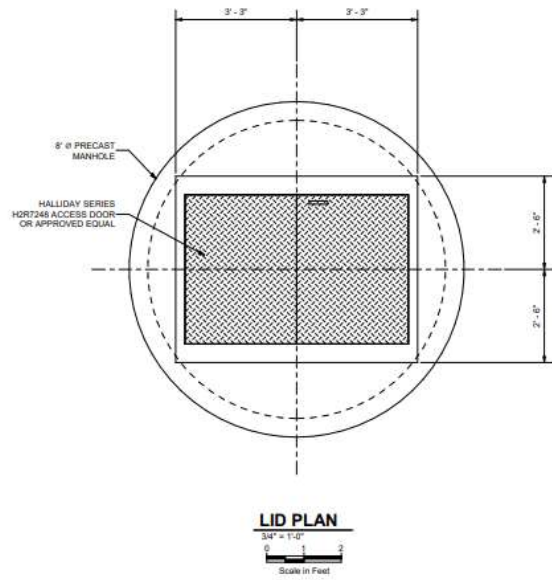
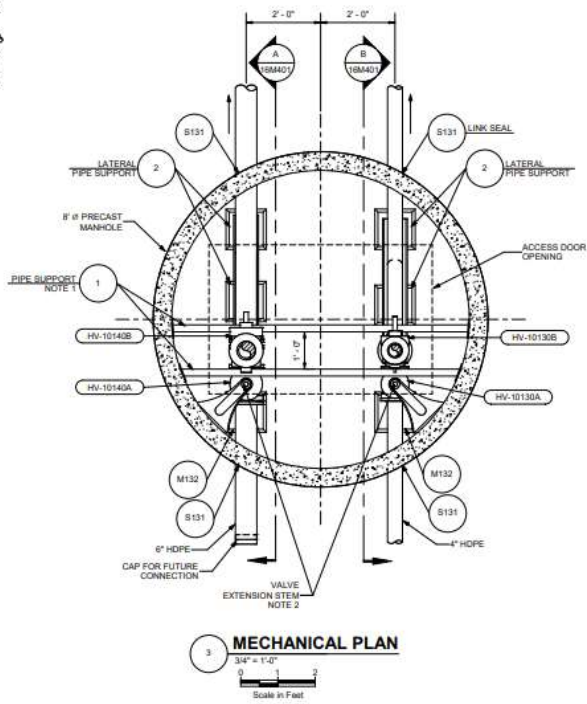

NOTES:

1. CONTRACTOR TO VERIFY LENGTH AND LOCATION OF PIPE SUPPORTS.
2. TRUMBULL VALVE EXTENSION STEM WITH STEM GUIDE AT 8'-0" MAX SPACING AND UNIVERSAL JOINTS AS REQUIRED.

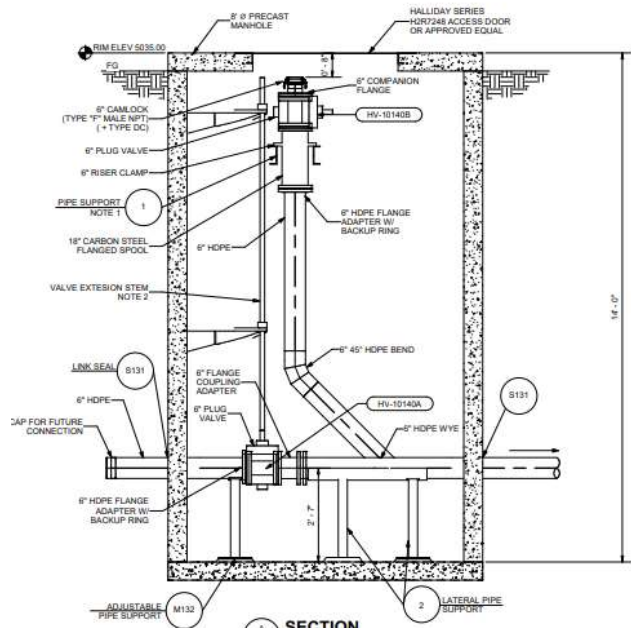

SECTION A
3/4" x 1'-0"
Scale in Feet

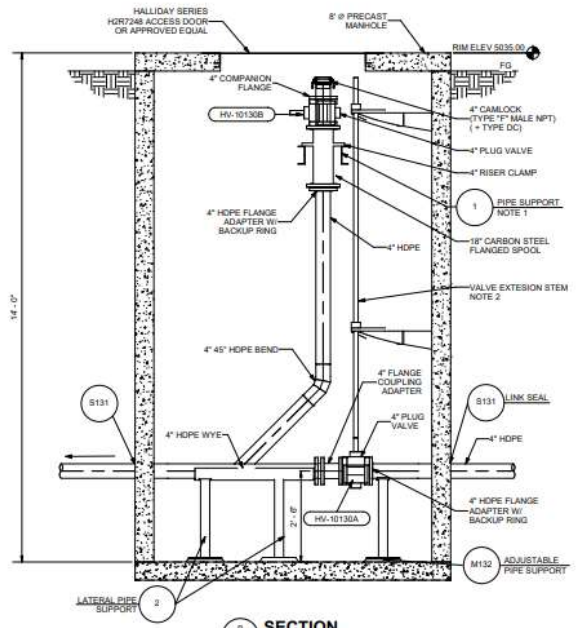

SECTION B
3/4" x 1'-0"
Scale in Feet

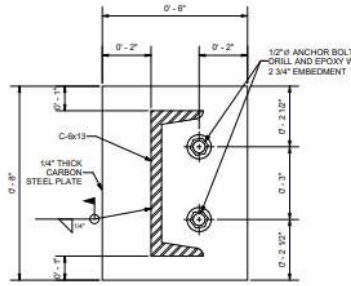

1 PIPE SUPPORT
NTS

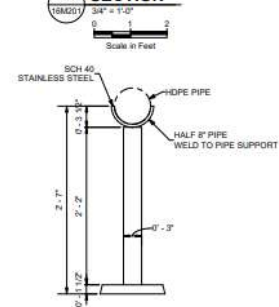

2 LATERAL PIPE SUPPORT
NTS

- NOTES:
1. CONTRACTOR TO VERIFY LENGTH AND LOCATION OF PIPE SUPPORTS.
 2. TRUMBULL VALVE EXTENSION STEM WITH STEM GUIDE AT 8'-0" MAX SPACING AND UNIVERSAL JOINTS AS REQUIRED.

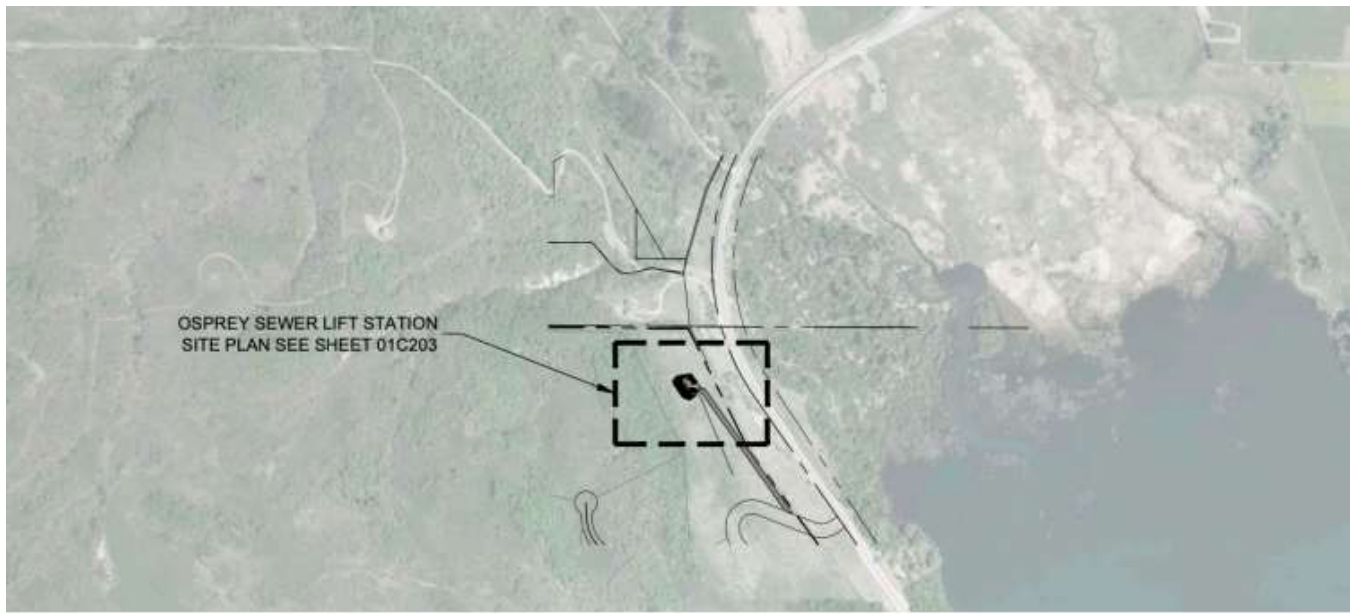

Exhibit B – Application and Narrative

Crossing LLC-Eden -Conditional Use Permits

[+ Add Follower](#) [/ Change Status](#) [/ Edit Project](#)

Address: 5204 East 2500 North Street, Eden , UT, 84310
Maps: [County Map](#), [Google Maps](#)
Project Type: Conditional Use Permits
Sub Type: Conditional Use Permits
Created By: Eric Householder
Created On: 8/30/2023

Project Status: Accepted
Status Date: 9/1/2023
File Number:
Project Manager

[Application](#) [Documents](#) [Comments](#) [Reviews](#) [Followers](#) [History](#) [Reminder](#) [Payments](#)

Application

[+ Add Building](#) [+ Add Parcel](#) [+ Add a Contractor](#) [/ Edit Application](#) [Print](#)

Project Description Brown Sewer Lift Station

Property Address 5204 East 2500 North Street
Eden , UT, 84310

Property Owner Eden Crossing LLC,
801-979-7989
shane@legacy-mountain.com

Representative Eric Householder
801-389-0040
eric@thg-cs.com

Accessory Dwelling Unit False

Current Zoning AV-3

Subdivision Name

Number of new lots being created 0

Lot Number

Lot Size

Frontage

Culinary Water Authority Not Applicable

Secondary Water Provider Not Applicable

Sanitary Sewer Authority Not Applicable

Nearest Hydrant Address

Signed By Representative, Eric Householder

Parcel Number

[✖ Remove](#) [224060002 - County Map](#)

Osprey and Brown Lift Stations
Conditional Use Permit Application
August 2023

Project Description

The proposed sewer lift stations will serve the existing Osprey Ranch project and the future developments of Eden Crossing and Cobabe Ranch. Locations of the two structures are included in the application material.

Each structure is the same in terms of size, materials, dimensions, etc. The buildings are 14'x28' (392 SF) and have grey block walls with a brown metal roof. All outside lighting will be dark sky compliant. Detailed plans for the buildings have been submitted.

The Wolf Creek Water & Sewer Improvement District will own and operate the lift station after construction is completed and the improvements are accepted.

Reasonably anticipated detrimental effects of a proposed conditional use can be substantially mitigated by the proposal or by the imposition of reasonable conditions to achieve compliance with applicable standards. Examples of potential negative impacts are odor, vibration, light, dust, smoke, or noise.

The lift stations will have all pumping equipment enclosed with sound reducing generators to mitigate noise resulting in the operational use.

That the proposed use will comply with the regulations and conditions specified in the Zoning Ordinance and other applicable agency standards for such use.

Public utilities are permitted under the FV-3 and AV-3 land use code as a Conditional Use for utility substations.



Staff Report to the Ogden Valley Planning Commission

Weber County Planning Division

Synopsis

Application Information

Application Request:	File No. CUP2023-11: Request for approval of a conditional use permit for a public utility substation for the Eden Crossing sewer lift station located at approximately 5204 E Highway 166, Eden, UT, 84310.		
Application Type:	Administrative		
Applicant:	Eden Crossing LLC		
Approximate Address:	5204 E Highway 166, Eden, UT, 84310.		
Project Area:	12,560 Square feet		
Zoning:	AV-3		
Existing Land Use:	Vacant		
Proposed Land Use:	Public Utility Substation		
Parcel ID:	22-406-0002		
Township, Range, Section:	Township 7 North, Range 1 East, Section 34 NE		

Adjacent Land Use

North:	Residential/Open Space	South:	Highway 166
East:	Residential	West:	Residential

Staff Information

Report Presenter:	Tammy Aydelotte taydelotte@webercountyutah.gov 801-399-8794
Report Reviewer:	SB

Applicable Ordinances

- Weber County Land Use Code Title 104 Chapter 2 (AV-3 Zone)
- Weber County Land Use Code Title 108 Chapter 4 (Conditional Uses)
- Weber County Land Use Code Title 108 Chapter 10 (Public Utility Substations)
- Weber County Land Use Code Title 108 Chapter 2 (Ogden Valley Architectural, Landscape, and Screening Standards)
- Weber County Land Use Code Title 108 Chapter 1 (Design Review)

Background and Summary

Applicant is requesting a conditional use permit for a sewer lift station to service the future developments of Eden Crossing and Cobabe Ranch. This proposed lift station will be owned, operated, and maintained by Wolf Creek Water and Sewer Improvement District.

The application is being processed as an administrative review due to the approval procedures in Uniform Land Use Code of Weber County, Utah (LUC) §108-1-2 which requires the planning commission to review and approve applications for conditional use permits and design reviews.

Analysis

General Plan: As a conditional use, this operation is allowed in the AV-3 Zone. With the establishment of appropriate conditions as determined by the land use authority, this operation will not negatively impact any of the goals and policies of the General Plan.

Zoning: The subject property is located within the AV-3 zone. The purpose and intent of the AV-3 zone are described in LUC 104-2-1:

“The AV-3 Zone and A-1 Zone are both an agricultural zone and a low-density rural residential zone. The purpose of the AV-3 Zone and A-1 Zone is to:

1. *Designate low-intensity farm areas, which are anticipated to develop in a rural residential development pattern;*
2. *Set up guidelines to continue agricultural pursuits, including the keeping of farm animals; and*
3. *Direct orderly low-density residential development in a continuing rural environment."*

The AV-3 zone allows the proposed use, as a conditional use. The proposed site plan indicates that the lift station meets the minimum setbacks for a public utility substation in the AV-3 zone (30' front, 10' rear, 10' feet from the south side lot line, 14 feet from the north lot line).

Under the LUC 108-10, there is not minimum lot area for public utility substations. The proposed improvements will be located on a site of approximately 12,560 square feet.

Conditional Use Review: A review process has been outlined in LUC §108-4-3 to ensure compliance with the applicable ordinances and to mitigate anticipated detrimental effects. The applicant has received approval from the County Engineering Division and the Weber Fire District for the proposal.

The following is an analysis of the proposal reviewed against the conditional use standards:

(1) Standards relating to safety for persons and property. The proposal is not anticipated or expected to negatively impact this property, surrounding properties, or persons. The applicant plans to re-seed any areas disturbed by construction in order to maintain the native vegetation.

(2) Standards relating to infrastructure, amenities, and services: The proposal is not anticipated or expected to negatively impact any existing infrastructure, amenities, or services in the area.

(3) Standards relating to the environment. The proposal is not anticipated or expected to negatively impact the environment.

(4) Standards relating to the current qualities and characteristics of the surrounding area and compliance with the intent of the general plan. The proposal is not anticipated to negatively impact the surrounding area, nor is it contrary to the recommendations of the general plan.

Design Review: The proposed conditional use mandates a design review as outlined in LUC §108-1 to ensure that the general design, layout and appearance of the building remains orderly and harmonious with the surrounding neighborhood. The matters for consideration are as follows:

Considerations relating to traffic safety and traffic congestion. The proposal includes a site plan that identifies an access to the pump house off of a proposed new road in phase two of the proposed Osprey Ranch Subdivision. Neither traffic safety hazards nor traffic congestion are anticipated given the minimal site visitations to the substations.

Considerations relating to landscaping. The applicant is proposing a gravel area immediately surrounding the proposed structures, and 7,536 area of hydro seed with a native seed mix (60% of overall site area) (108-2).

Considerations relating to buildings and site layout. The applicant has indicated the lift station will be located in an enclosed structure consisting of CMU. Per Weber County LUC 108-2-4, "...street sides of buildings shall be constructed of non-reflective materials and shall be textured concrete, brick, stone and/or natural wood/wood-like materials. Concrete masonry units or block CMUs shall not be considered acceptable materials unless it is specially colored and textured to give an appearance of natural rough stone. Vinyl and/or aluminum siding shall not be acceptable." *"Color.* External surfaces shall be predominantly natural, muted earth tones. White may only be used as an accent color. The roof of an addition to an existing structure, when matching existing colors, shall be exempt." "Exposed metal shall be painted, stained, or anodized in permitted colors and shall be non-reflective. Copper, brass and wrought iron may remain untreated and allowed to develop a natural patina."

Applicant shall provide more detail on colors and materials, which are compliant with the above requirements, when submitting for a building permit.

Review Agencies: Weber Fire District has approved this application. Weber County Engineering has not yet reviewed this application, and a conditional use permit will not be issued until all required review agencies have their conditions met.

Staff Recommendation

Staff recommends approval of this conditional use application subject to the applicant meeting the review agency requirements and the following conditions:

1. Any outdoor lighting must meet the requirements of the Ogden Valley Outdoor Lighting Ordinance (108-16).
2. All architectural requirements shall be followed, and shown in the final engineered plans, prior to issuance of a building conditional use permit.

This recommendation is based on the following findings:

1. The proposed use is allowed in the AV-3 zone and meets the appropriate site development standards.
2. The criteria for issuance of a conditional use permit have been met because mitigation of potential detrimental effects can be accomplished.

Exhibits

- A. Building elevations and Site Plan
- B. Application and Narrative

Map 1



Exhibit A - Building Elevations and Site Plan

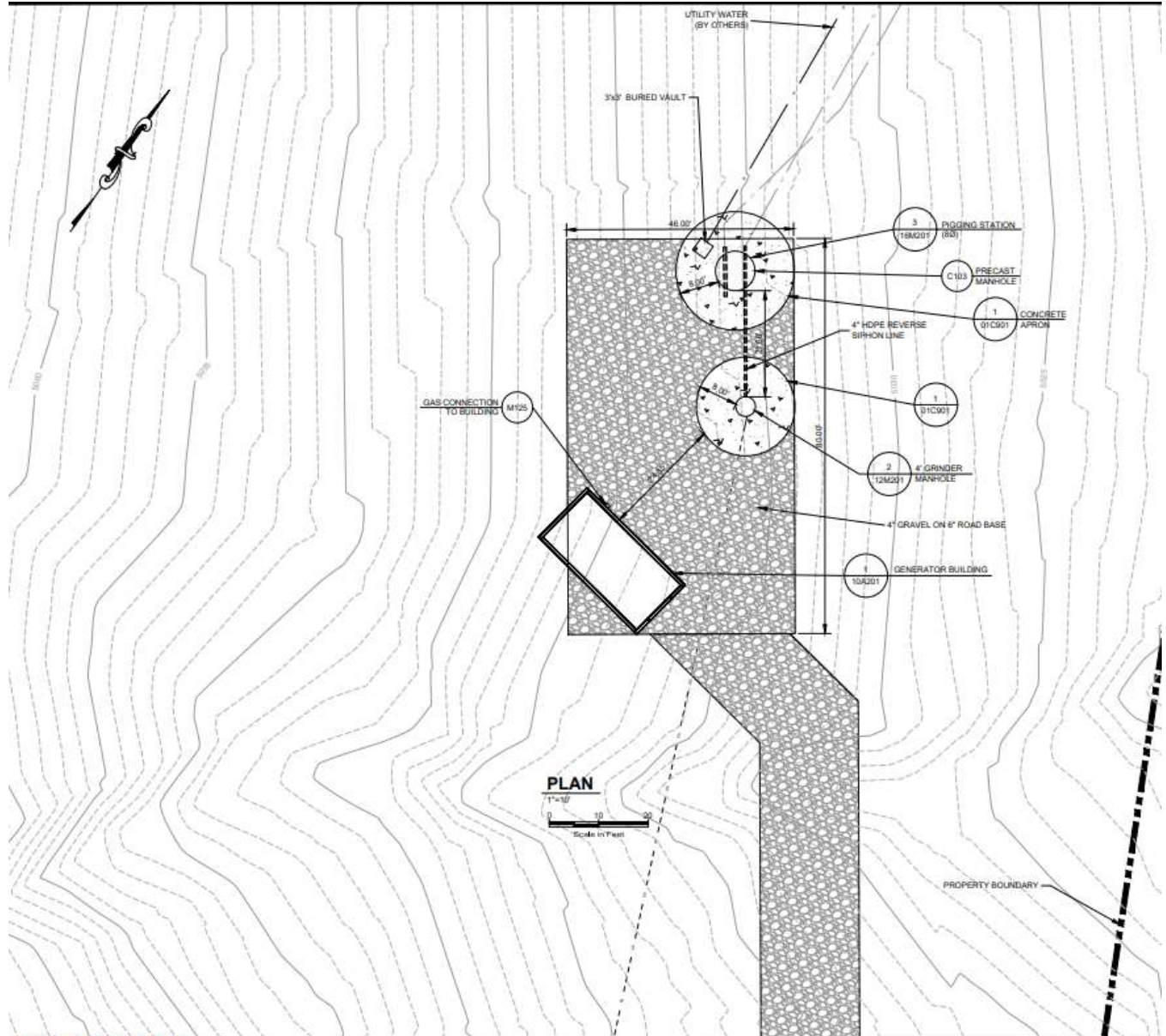

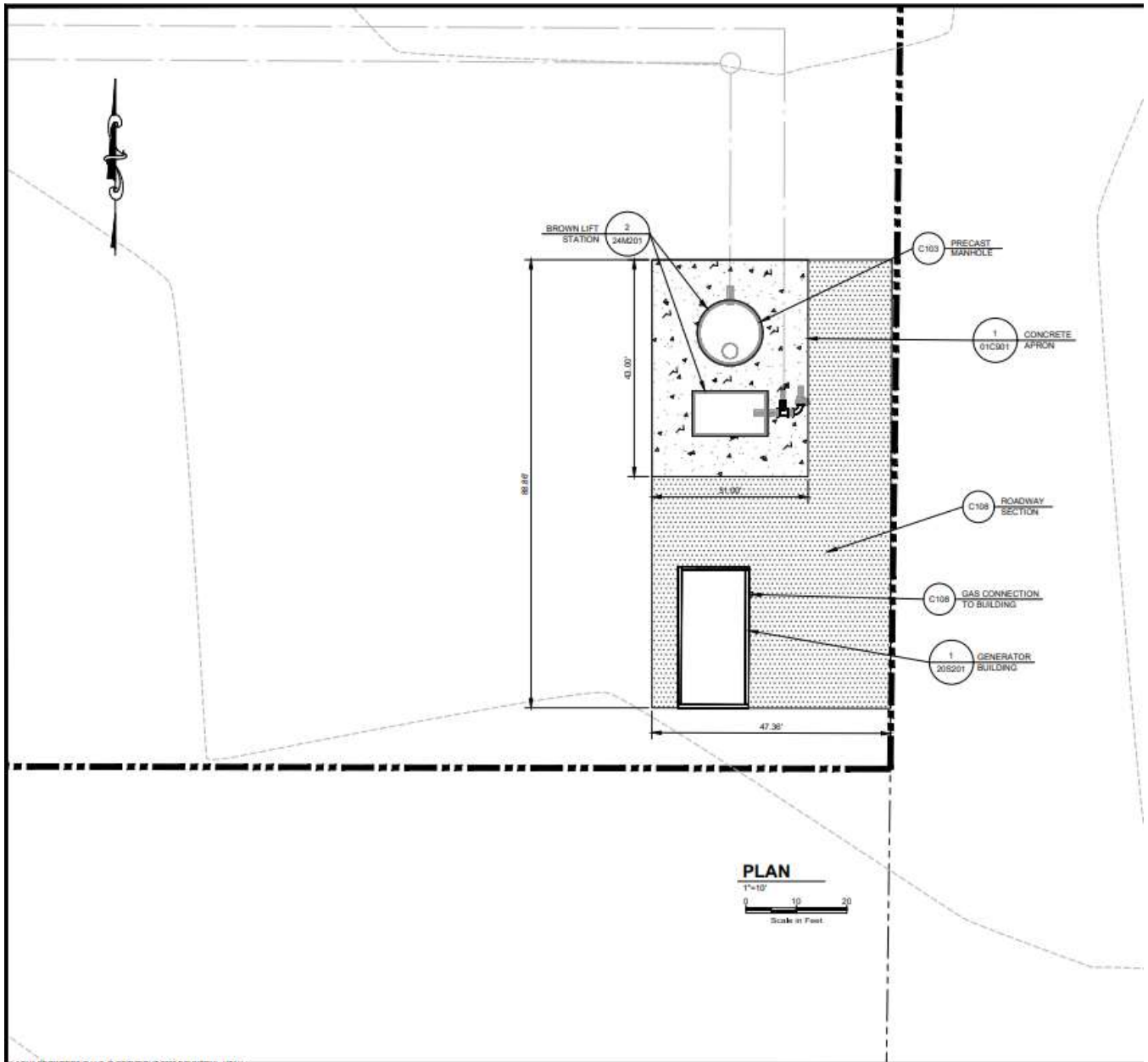

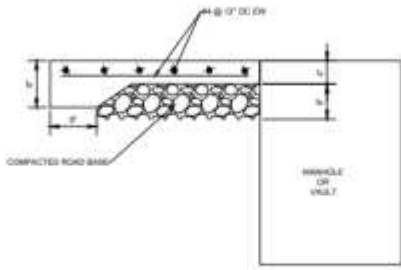

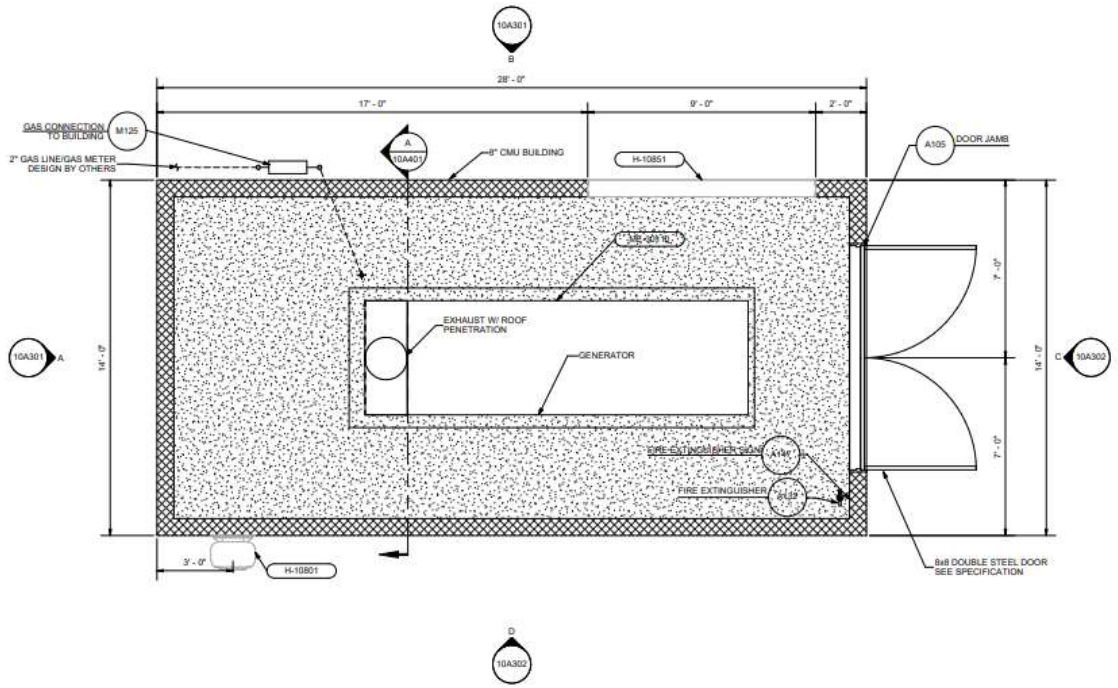

CONCRETE APRON
 1:10 (V.P.)

 Scale: 1" = 10'

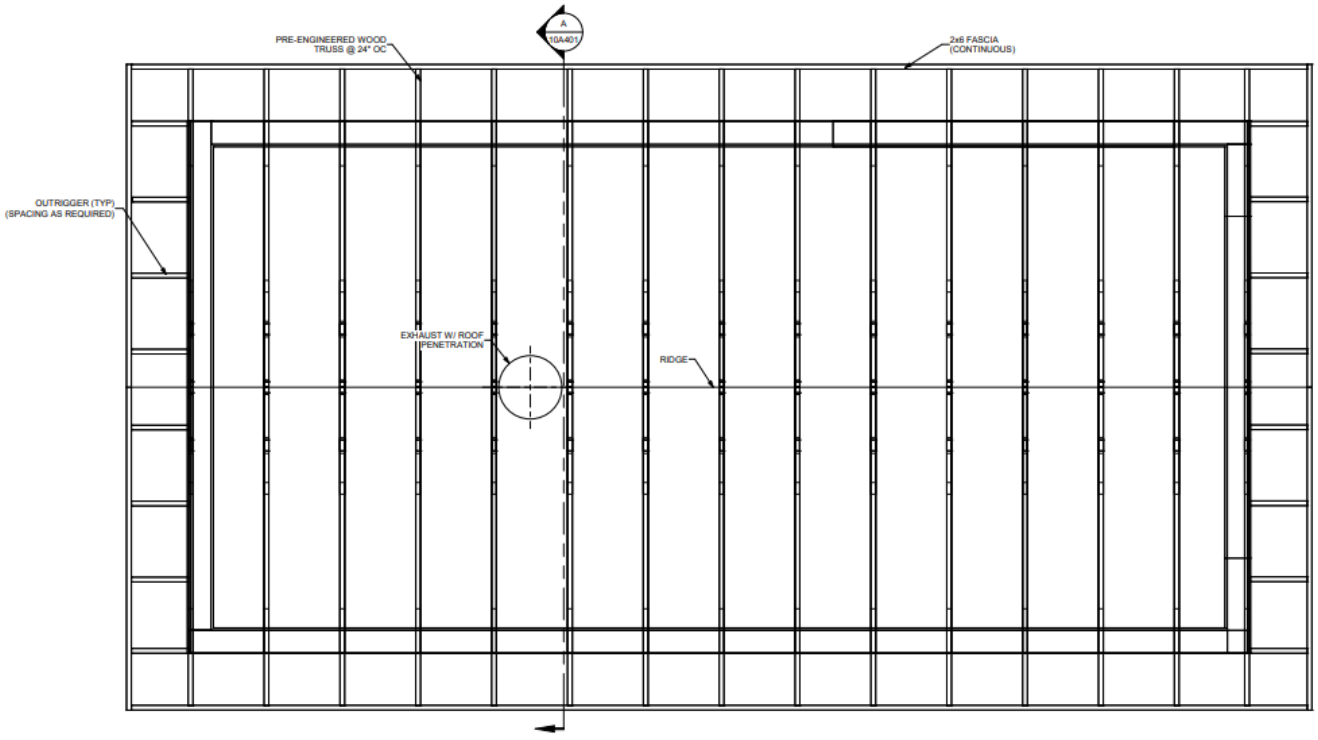

1 ARCHITECTURAL PLAN
1/2" = 1'-0"
Scale in Feet



JOINT DESIGN CRITERIA

DESIGN LOAD: 20 PSF
 ROOF LIVE LOAD: 20 PSF
 ROOF SNOW LOAD: 57 PSF
 LINE LOAD DEFLECTION: L/360

TRUSSES TO BE DESIGNED BY MANUFACTURER AND SUBMITTED TO ENGINEER ON RECORD FOR APPROVAL.

ACTUAL LOCATION AND DESIGN OF BRIDGING SHALL BE PROVIDED BY MANUFACTURER AND SUBMITTED TO ENGINEER ON RECORD PRIOR TO ERECTION OF TRUSSES.

SEE GENERAL STRUCTURAL NOTES FOR INSPECTION AND REQUIREMENTS.

ROOF PLAN
 3/4" = 1'-0"
 0 1 2
 Scale in Feet

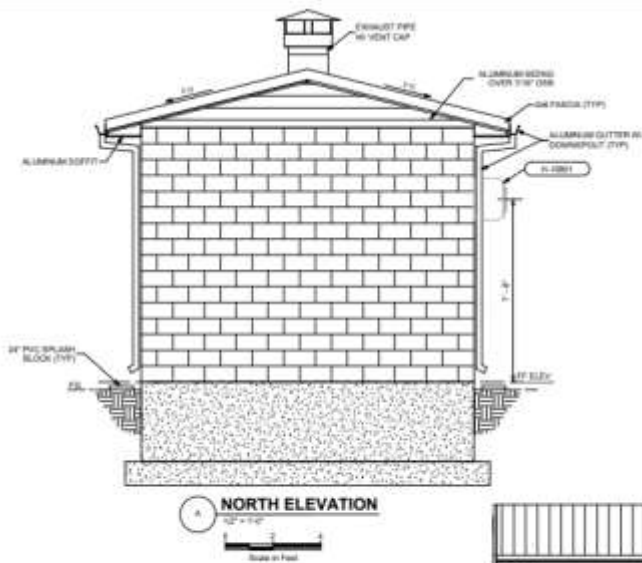

A
NORTH ELEVATION
 1/2" = 1'-0"
 Scale in Feet

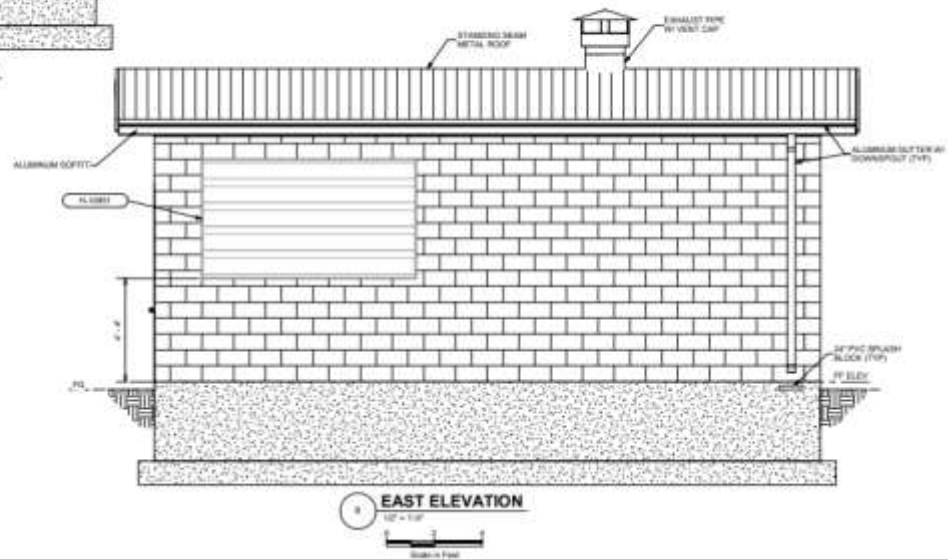

B
EAST ELEVATION
 1/2" = 1'-0"
 Scale in Feet

ARCHITECTURAL FIRM NAME ADDRESS, CITY

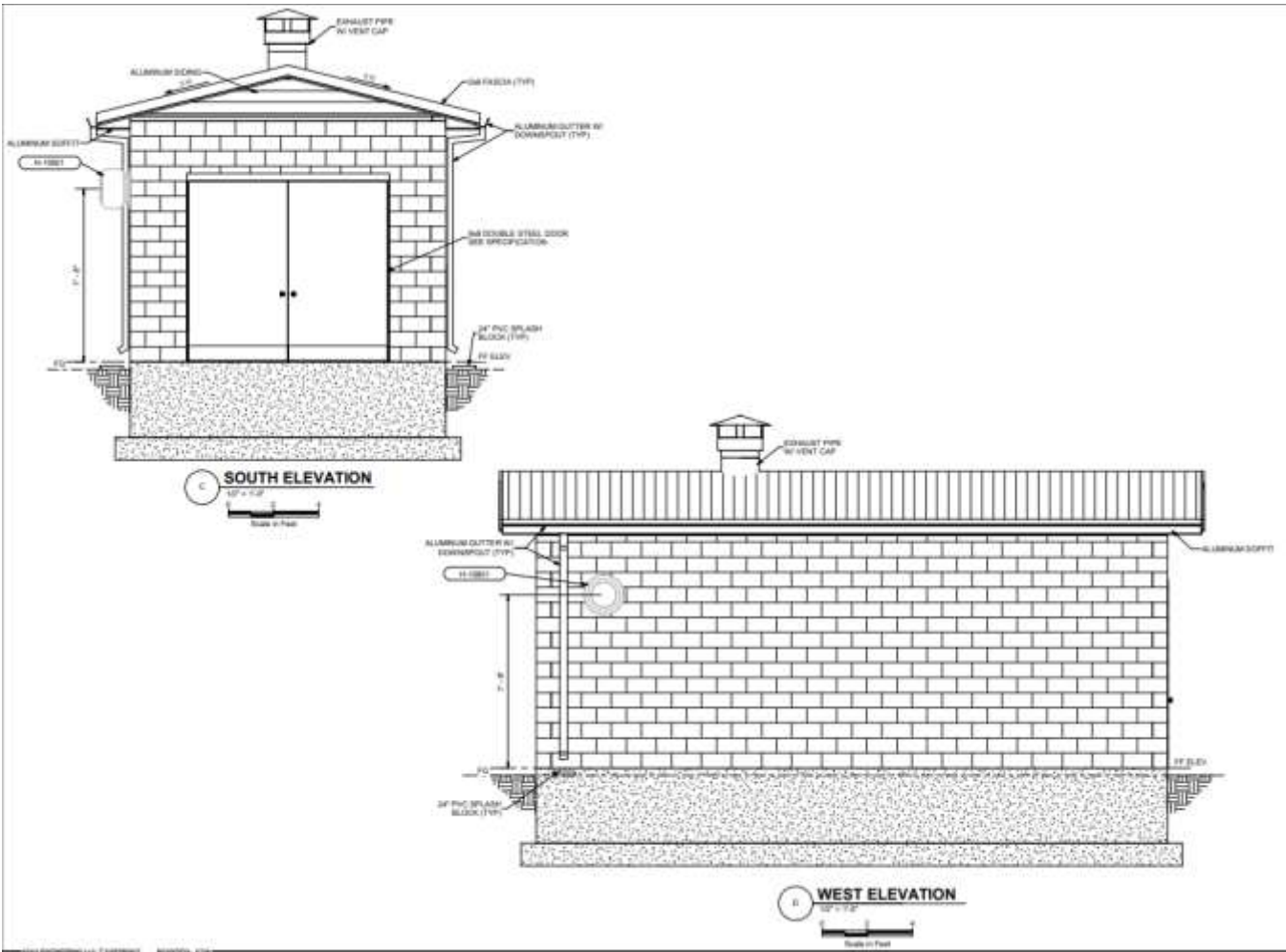

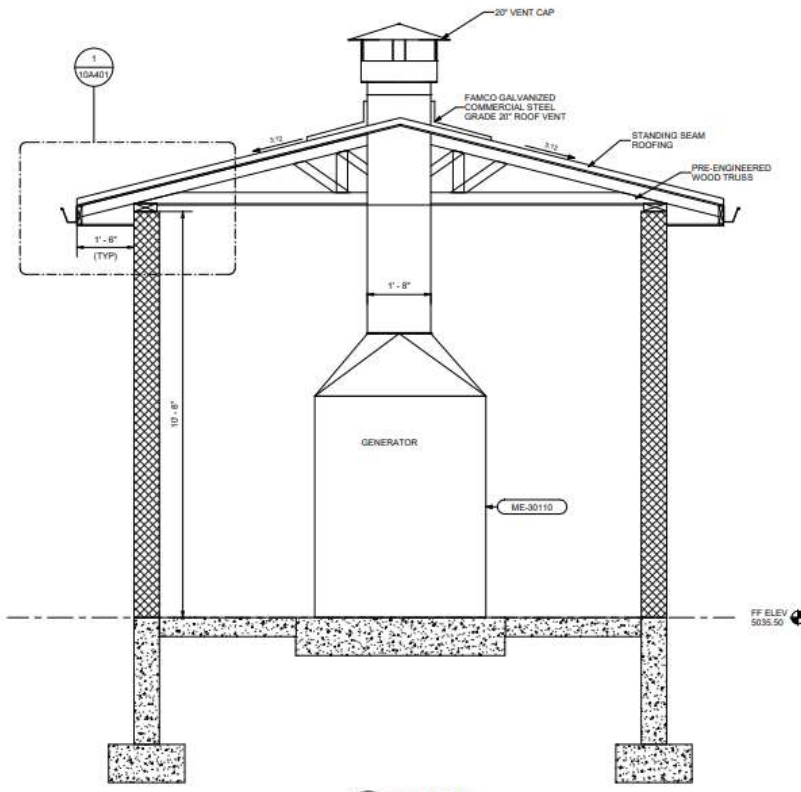

A SECTION
 10A201 3/4" = 1'-0"
 Scale in Feet

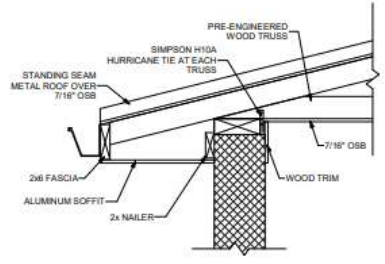

1 DETAIL
 1 1/2" = 1'-0"
 Scale in Feet

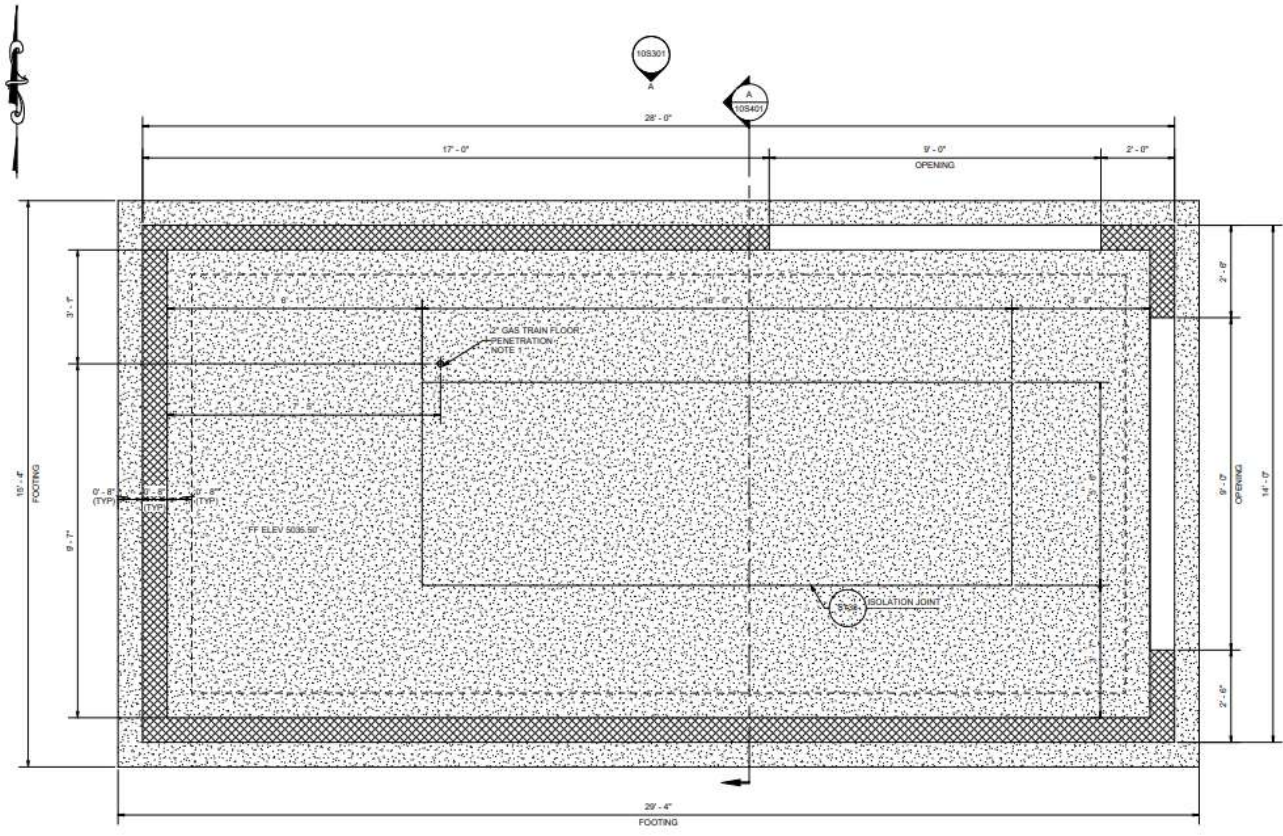

STRUCTURAL PLAN

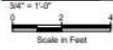

NOTES:

1. FIELD VERIFY LOCATION CORRELATES WITH GENERATOR GAS CONNECTION LOCATION.

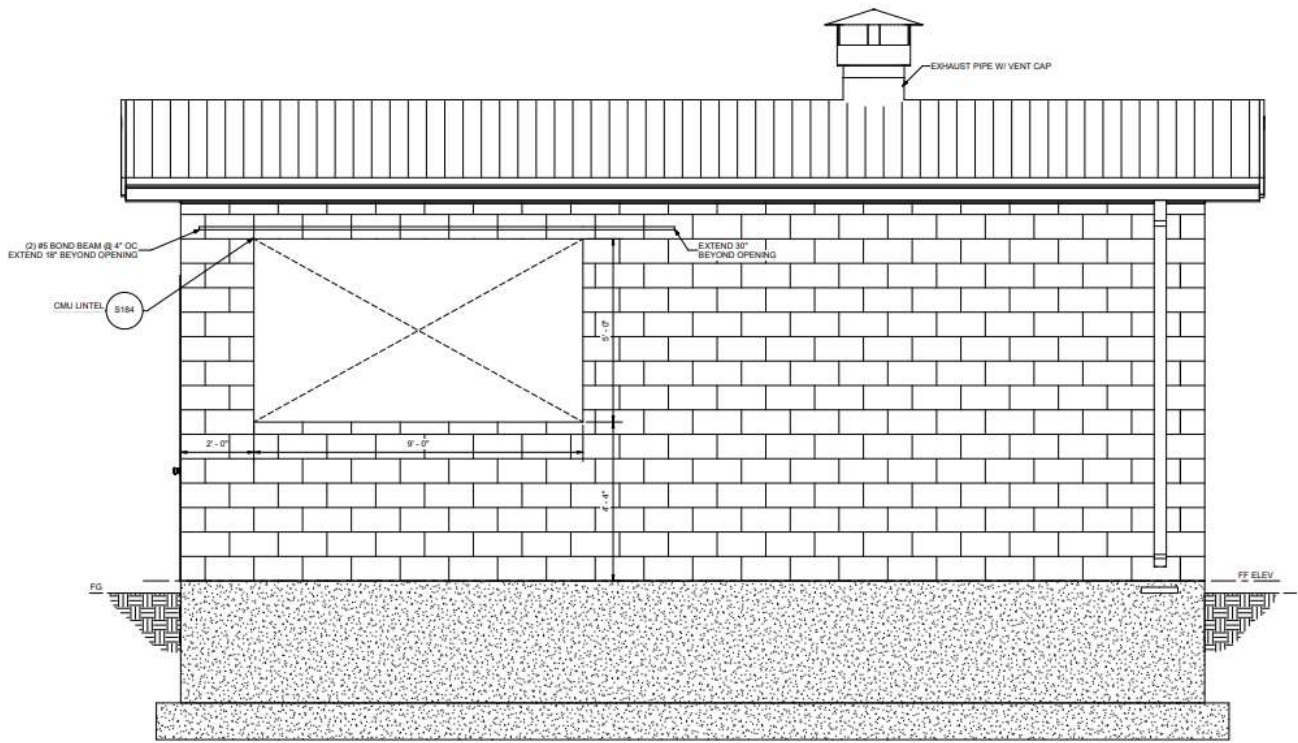

A
NORTH ELEVATION
 3/4" = 1'-0"
 Scale in Feet

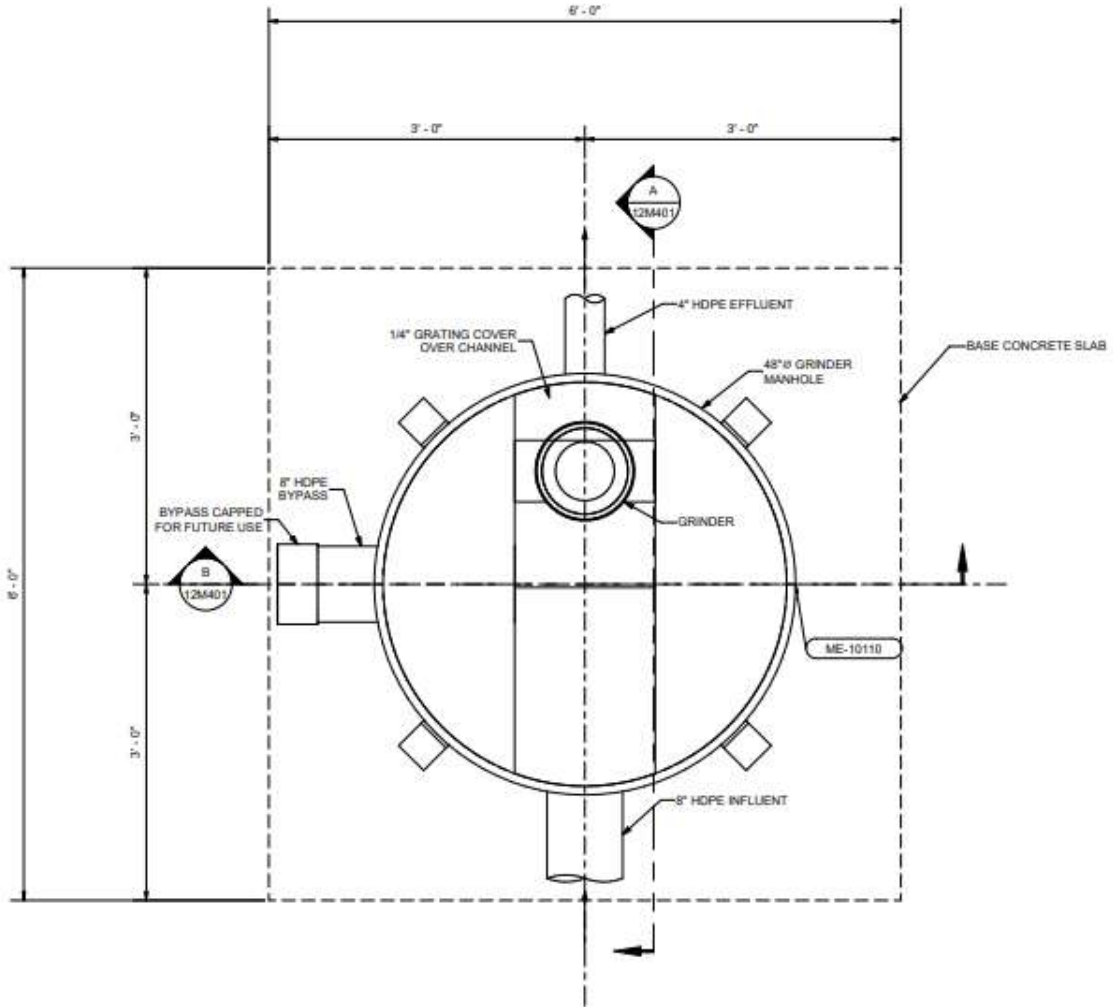

2 **MECHANICAL PLAN**
1 1/2" = 1'-0"
0 1 2
Scale in Feet

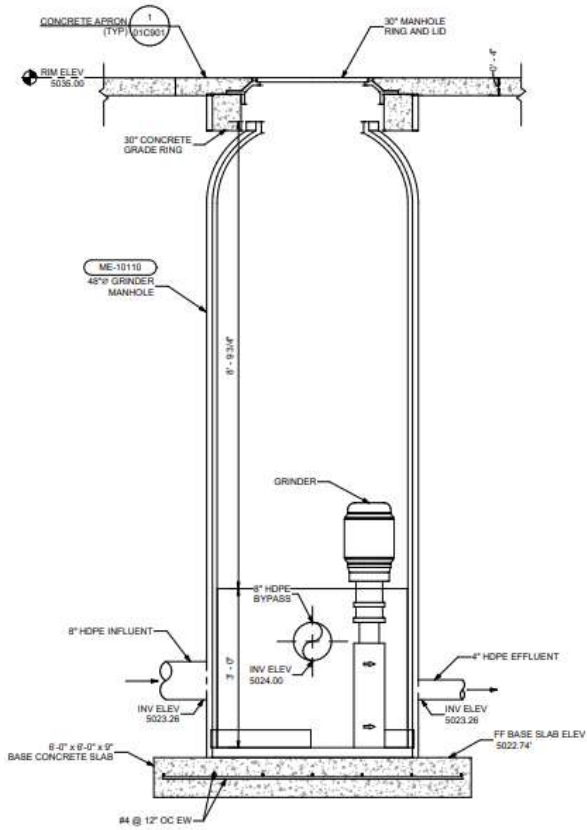

A SECTION
 12M201 1" = 1'-0"
 Scale in Feet

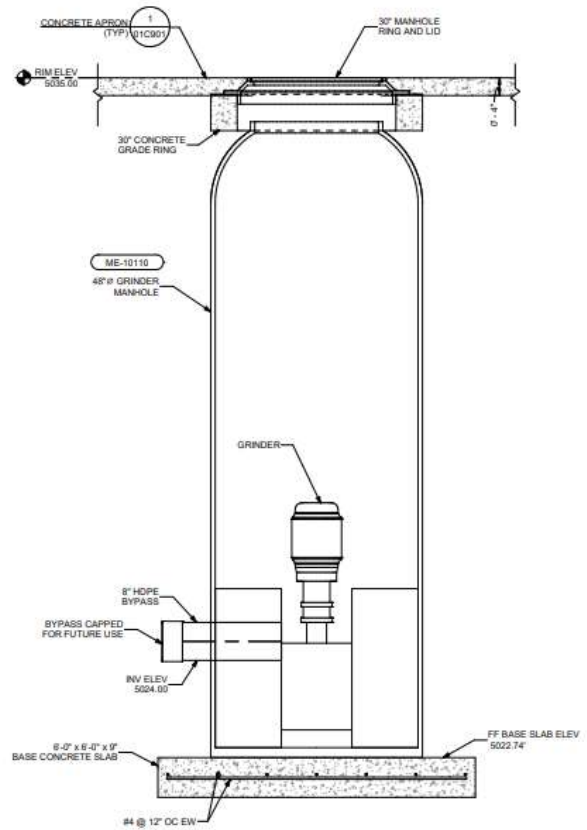

B SECTION
 12M201 1" = 1'-0"
 Scale in Feet

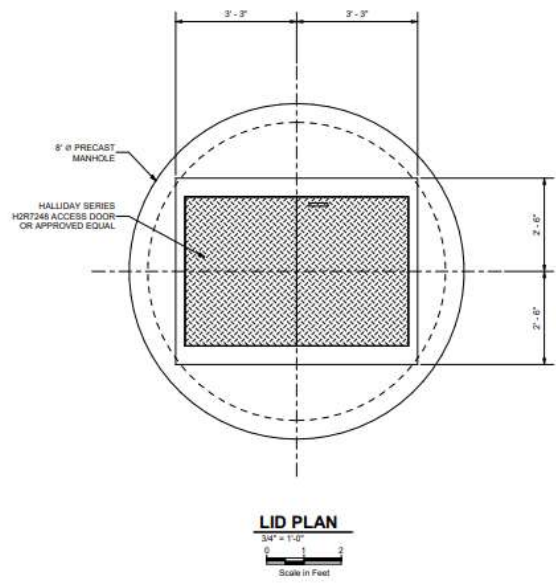
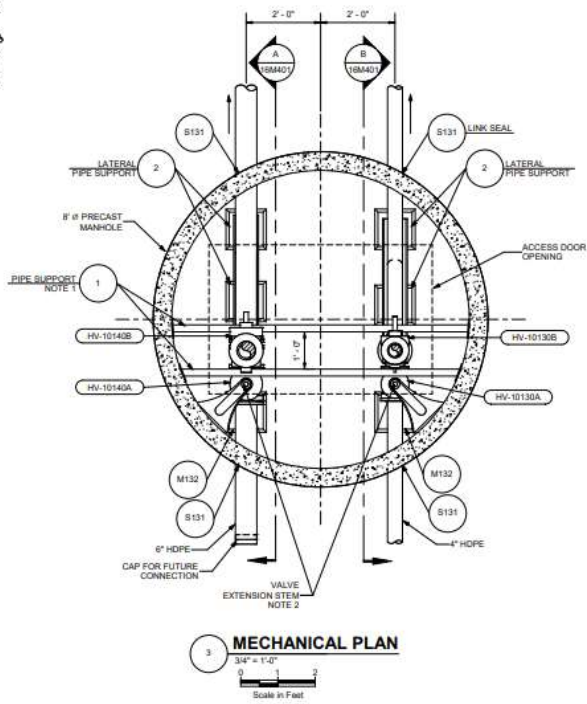

- NOTES:
1. CONTRACTOR TO VERIFY LENGTH AND LOCATION OF PIPE SUPPORTS.
 2. TRUMBULL VALVE EXTENSION STEM WITH STEM GUIDE AT 8'-0" MAX SPACING AND UNIVERSAL JOINTS AS REQUIRED.

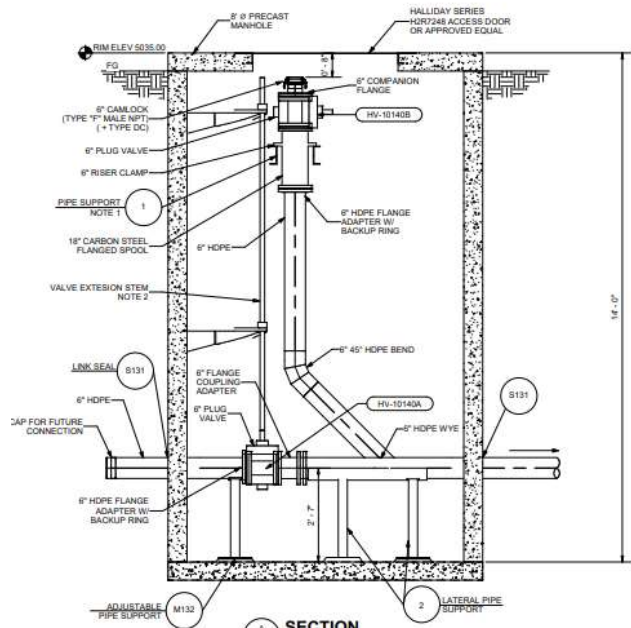

SECTION A
3/4" x 1'-0"
Scale in Feet

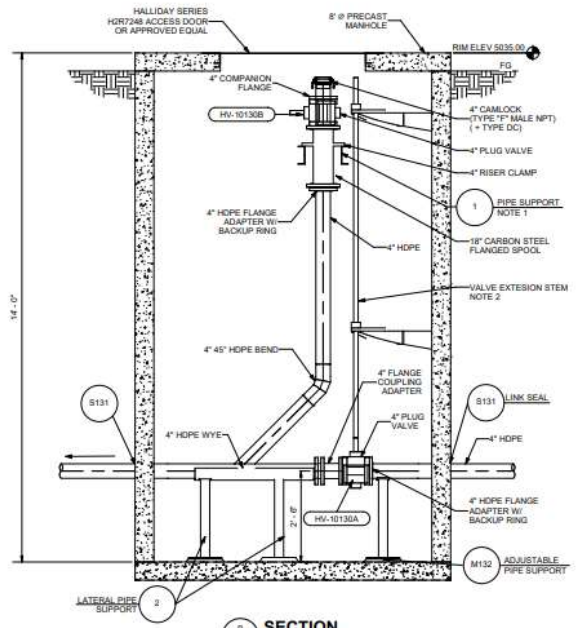

SECTION B
3/4" x 1'-0"
Scale in Feet

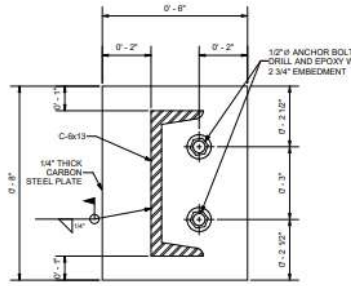

1 PIPE SUPPORT
NTS

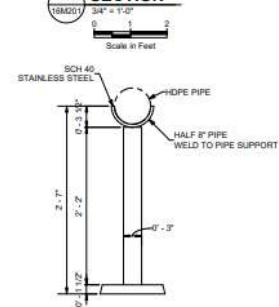

2 LATERAL PIPE SUPPORT
NTS

- NOTES:
1. CONTRACTOR TO VERIFY LENGTH AND LOCATION OF PIPE SUPPORTS.
 2. TRUMBULL VALVE EXTENSION STEM WITH STEM GUIDE AT 8'-0" MAX SPACING AND UNIVERSAL JOINTS AS REQUIRED.

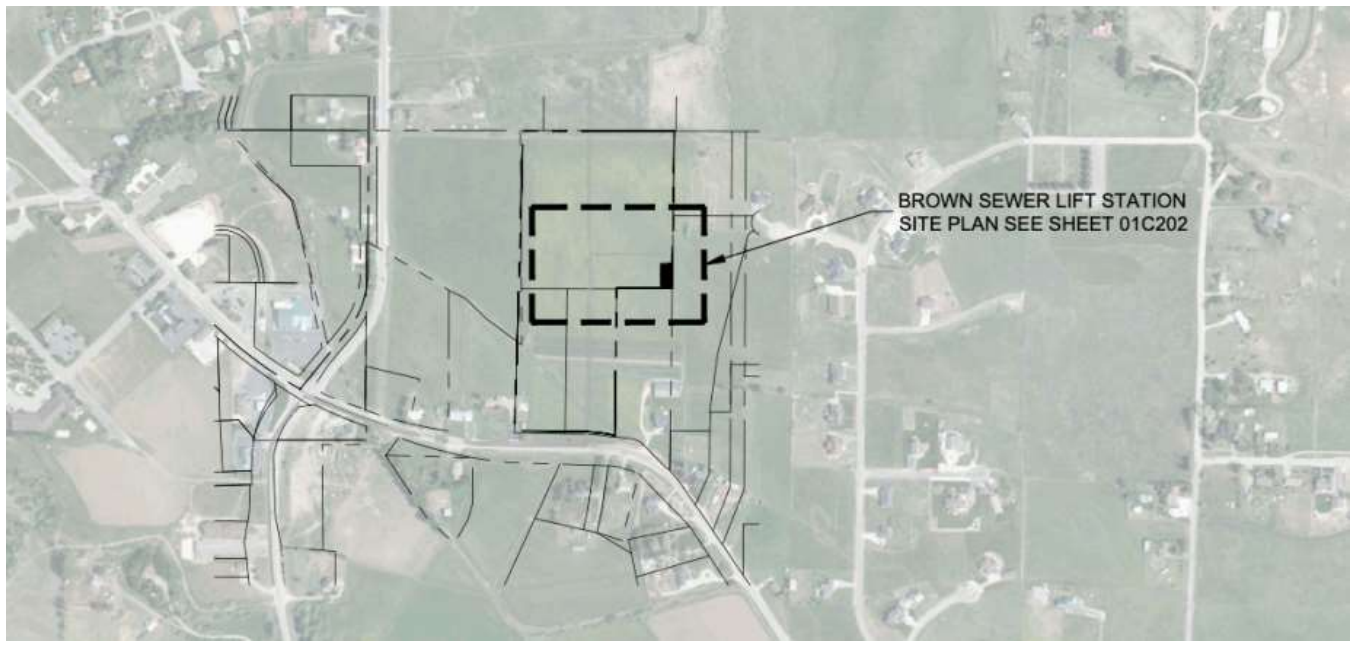

Exhibit B – Application and Narrative

Crossing LLC-Eden -Conditional Use Permits

[+ Add Follower](#) [/ Change Status](#) [/ Edit Project](#)

Address: 5204 East 2500 North Street, Eden , UT, 84310
Maps: [County Map](#), [Google Maps](#)
Project Type: Conditional Use Permits
Sub Type: Conditional Use Permits
Created By: Eric Householder
Created On: 8/30/2023

Project Status: Accepted
Status Date: 9/1/2023
File Number:
Project Manager

[Application](#) [Documents](#) [Comments](#) [Reviews](#) [Followers](#) [History](#) [Reminder](#) [Payments](#)

Application

[+ Add Building](#) [+ Add Parcel](#) [+ Add a Contractor](#) [/ Edit Application](#) [Print](#)

Project Description Brown Sewer Lift Station

Property Address 5204 East 2500 North Street
Eden , UT, 84310

Property Owner Eden Crossing LLC,
801-979-7989
shane@iegacy-mountain.com

Representative Eric Householder
801-389-0040
eric@thg-cs.com

Accessory Dwelling Unit False

Current Zoning AV-3

Subdivision Name

Number of new lots being created 0

Lot Number

Lot Size

Frontage

Culinary Water Authority Not Applicable

Secondary Water Provider Not Applicable

Sanitary Sewer Authority Not Applicable

Nearest Hydrant Address

Signed By Representative, Eric Householder

Parcel Number

[✖ Remove](#) [224060002 - County Map](#)

Osprey and Brown Lift Stations
Conditional Use Permit Application
August 2023

Project Description

The proposed sewer lift stations will serve the existing Osprey Ranch project and the future developments of Eden Crossing and Cobabe Ranch. Locations of the two structures are included in the application material.

Each structure is the same in terms of size, materials, dimensions, etc. The buildings are 14'x28' (392 SF) and have grey block walls with a brown metal roof. All outside lighting will be dark sky compliant. Detailed plans for the buildings have been submitted.

The Wolf Creek Water & Sewer Improvement District will own and operate the lift station after construction is completed and the improvements are accepted.

Reasonably anticipated detrimental effects of a proposed conditional use can be substantially mitigated by the proposal or by the imposition of reasonable conditions to achieve compliance with applicable standards. Examples of potential negative impacts are odor, vibration, light, dust, smoke, or noise.

The lift stations will have all pumping equipment enclosed with sound reducing generators to mitigate noise resulting in the operational use.

That the proposed use will comply with the regulations and conditions specified in the Zoning Ordinance and other applicable agency standards for such use.

Public utilities are permitted under the FV-3 and AV-3 land use code as a Conditional Use for utility substations.