

**Storm Water Pollution Prevention Plan**  
**for**  
**Overlook Point**  
**E. Overlook Drive, Eden, Utah 84310**

**Operator:**

**Geneva Rock Products**  
**Casey Harris, Project Manager**  
**1235 West Stock Road**  
**Ogden, Utah 84401**  
**Cell: 435-994-0619**  
**charris@generock.com**

**Primary SWPPP Contact**

Express Environmental Services, Inc.  
Jennie Gallegos  
3269 Hidden Peak Rd.  
Erda, UT 84074  
Phone: 435-833-0150  
Fax: 435-833-0149 / Email: JennieG@ExpressEnvironmentalServices.com

**SWPPP Preparation Date:**

07/21/2023

**UPDES Permit Tracking Number:**

**UTRC07218**

---

## Contents

---

SECTION 1: CONTACT INFORMATION/ RESPONSIBLE PARTIES .....	1
1.1 Storm Water Team .....	1
SECTION 2: NATURE OF CONSTRUCTION ACTIVITIES .....	2
2.1 Construction Site Estimates .....	2
2.2 Construction Activity Descriptions .....	2
2.3 Phase/Sequence of Construction Activity.....	3
2.4 Maps.....	4
3.1 Discharge Information .....	6
3.2 Receiving Waters .....	6
3.3 Impaired Waters .....	6
3.4 High Water Quality .....	7
SECTION 4: POLLUTION PREVENTION STANDARDS.....	8
4.1 Potential Sources of Pollution.....	8
4.2 Non-Storm Water Discharges.....	9
4.3 Dewatering Practices.....	10
4.4 Natural Buffers or Equivalent Sediment Controls.....	11
SECTION 5: EROSION AND SEDIMENT CONTROLS – BMPS.....	12
5.1 List of Erosion and Sediment BMPs on Site.....	12
5.1.1 Minimize Disturbed Area and Preserve Vegetation and Soil.....	14
5.1.2 Establish Perimeter Controls and Sediment Barriers .....	15
5.1.3 Establish Stabilized Construction Exits .....	16
5.1.4 Stockpiled Soil or Other Erodible Material.....	17
5.1.5 Minimize Dust .....	18
5.1.6 Protect Slopes .....	19
5.1.7 Stockpiled Soil or Other Erodible Material.....	20
5.1.8 Soil Compaction.....	21
5.1.9 Protect Storm Drain Inlets.....	22
5.1.10 Control Storm Water Flowing onto and through the Project.....	23
5.1.11 Retain Sediment On-Site .....	24
5.1.12 Construction and Domestic Waste .....	25
5.1.13 Stabilize Soils .....	27
5.2 Linear Site Perimeter Control Exemption .....	28
5.3 Final Stabilization .....	28
SECTION 6: BMPS - POLLUTION PREVENTION/OPERATIONAL CONTROLS.....	29
6.1 Spill Prevention and Response .....	29
6.2 Pollution Prevention Controls .....	32
6.2.1 Establish Proper Equipment/Vehicle Fueling and Maintenance Practices.....	34



6.2.2	Control Equipment/Vehicle Washing .....	35
6.2.3	Establish Proper Building Material Staging Areas .....	35
6.2.4	Washing of Applicators and Containers used for Concrete, Paint or Other Materials.	36
6.2.5	Pesticides, Herbicides, Insecticides, Fertilizers, and Landscape Materials .....	37
7.1	Emergency Related Projects .....	38
7.2	UIC Class 5 Injection Wells .....	38
7.3	Chemical Treatment .....	39
SECTION 8: INSPECTIONS & CORRECTIVE ACTIONS .....		41
8.1	Inspections .....	41
8.2	Corrective Actions .....	42
8.3	Delegation of Authority .....	42
SECTION 9: RECORDKEEPING .....		43
9.1	Recordkeeping .....	43
9.2	Log of Changes to the SWPPP .....	44
SECTION 10: CERTIFICATION .....		45
SECTION 11: SWPPP PREPARER CERTIFICATION .....		46

Appendix A – Site Maps

Appendix B – NOI

Appendix C – Inspection Reports

Appendix D –Corrective Action Report

Appendix E – Subcontractor Certifications/Agreements/Delegation of Authority

Appendix F – Training Logs (CGP Part 6) and Certifications

Appendix G – Additional Information (i.e., Other permits and out of date SWPPP documents)

Appendix H – BMP Specifications

Appendix I – Construction General Permit

## SECTION 1: CONTACT INFORMATION/ RESPONSIBLE PARTIES

### 1.1 Storm Water Team

Name and/or Position, and Contact	Responsibilities, Qualifications, and Training
Overlook Point LLC PO Box 388 7843 East Horizon Run, Cabin 126 Eden, UT 84310 Scott Bailey Phone: 562-260-7369	Owner – responsible for total site
Casey Harris Geneva Rock Products 1235 West Stock Road Ogden, UT 84401 Project Manager 435-994-0619 charris@genevarock.com	Project Manager – responsible for total site
Jaysen Jorgensen Geneva Rock Products 1235 West Stock Road Ogden, UT 84401 Project Superintendent 801-678-9080	Project Superintendent – responsible for total site
Alfredo Gallegos Express Environmental Services, Inc. President 801-558-6240 AlfredoG@expressenvironmentalservices.com	Responsible for development of SWPP Plan, Inspections, Installation

## **SECTION 2: NATURE OF CONSTRUCTION ACTIVITIES**

### **2.1 Construction Site Estimates**

The following are estimates for the construction site.

Total project area (lot size):	Approx. 1.3 acres
Construction site area to be disturbed:	Approx. 1.3 acres

### **2.2 Construction Activity Descriptions**

**Instructions (CGP 7.3.2.a., d. & g.):**

- Briefly describe the nature of the construction activity and approximate time frames.
- For more information see CGP Part 7.3.2 and *SWPPP Guide*, Chapter 3.A.reconstruc

Describe the general scope of the work for the project, major phases of construction, etc.:  
This SWPPP will cover the work performed for the Overlook Point project located in Eden, Utah.

The Overlook Point project will consist of the roadway and infrastructure of the site, for the project as laid out in the plans. All associated paved walkways, and utilities will be completed for the project site as required. Landscaping Improvements, seeding, blanket or trees as required.

Typical site business days and times:

Work will be performed Monday-Saturday during daylight hours.

## **2.3 Phase/Sequence of Construction Activity**

### **Phase I - Before any site grading activities begin**

- Install perimeter silt fences
- Install storm drain inlet protection on at existing inlets
- Construct stabilized construction exits

### **Phase II - Site grading**

- Begin site clearing and grubbing operations
- Begin overall site grading and topsoil stripping
- Establish topsoil stockpile
- Install silt fences around stockpile and cover stockpiles
- Disturbed areas where construction will cease for more than 14 days will be stabilized with erosion controls

### **Phase III - Infrastructure (utilities, parking lot, etc.) & building construction**

- Construct staging and materials storage area
- Install temporary sanitary facilities and dumpsters
- Install utilities, sanitary sewers, and water services
- Construct temporary concrete washout area
- Begin construction of any structures
- Install gutters, curbs, and prepare pavement subgrade

### **Phase IV - Final stabilization and landscaping**

- Remove temporary concrete washout area
- Finalize pavement activities
- Remove all temporary control BMPs and stabilize any areas disturbed by their removal with permanent erosion controls
- Prepare and install final landscaping
- Monitor stabilized areas until final stabilization is reached

**(See construction project manual for more exact dates of events in the described Phases.)**



## 2.4 Maps

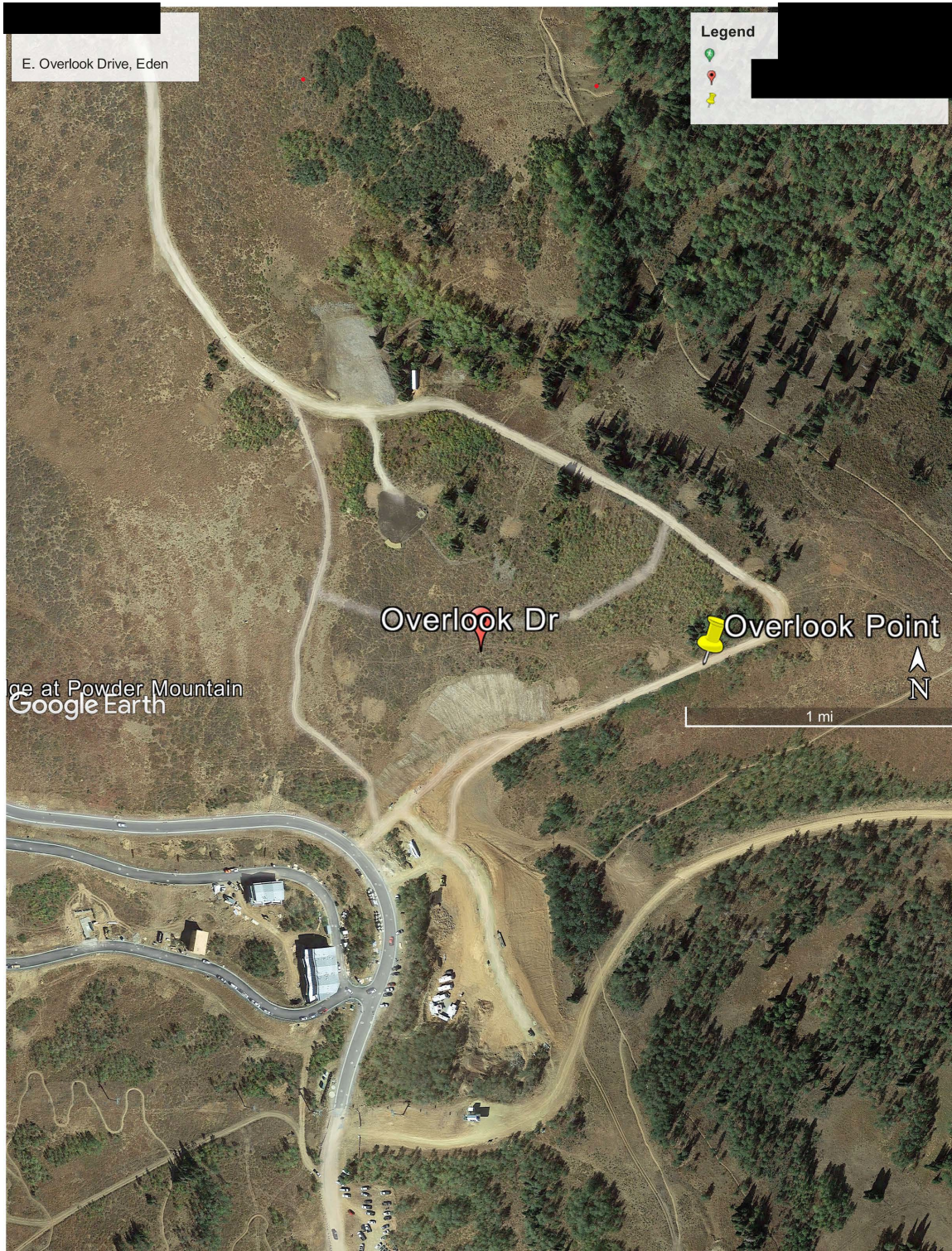

The SWPPP site map(s) are filed in Appendix A

Utah SWPPP Template, February 2021



**POWDER POINT  
 AT POWDER MOUNTAIN  
 DESIGN DEVELOPMENT DRAWINGS**

*Located in Weber County, Utah*

SHEET NO.	SHEET DESCRIPTION
C000	COVER SHEET
C001	GENERAL NOTES
C002	TYPICAL ROAD AND PAVEMENT SECTIONS
C003	DEMOLITION & SITE PLAN
C004	GRADING PLAN
C005	UTILITY PLAN
C006	PLAN AND PROFILE
C007	OFFSET CENTER LINE PLAN AND PROFILE
C008	DRAINAGE CHANNEL PLAN AND PROFILE
C009	STORMWATER CONVEYANCE PLAN AND PROFILE
C010	EROSION CONTROL PLAN
C011	SPACE EROSION CONTROL
C700	DETAILS
C701	DETAILS
C702	DETAILS
C703	DETAILS
C704	DETAILS
C705	DETAILS
C706	DETAILS
C707	DETAILS
C708	DETAILS
C709	DETAILS
C710	DETAILS
C711	DETAILS
C712	DETAILS
C713	DETAILS
C714	DETAILS
C715	DETAILS
C716	DETAILS
C717	DETAILS
C718	DETAILS
C719	DETAILS
C720	DETAILS
C721	DETAILS
C722	DETAILS
C723	DETAILS
C724	DETAILS
C725	DETAILS
C726	DETAILS
C727	DETAILS
C728	DETAILS
C729	DETAILS
C730	DETAILS
C731	DETAILS
C732	DETAILS
C733	DETAILS
C734	DETAILS
C735	DETAILS
C736	DETAILS
C737	DETAILS
C738	DETAILS
C739	DETAILS
C740	DETAILS
C741	DETAILS
C742	DETAILS
C743	DETAILS
C744	DETAILS
C745	DETAILS
C746	DETAILS
C747	DETAILS
C748	DETAILS
C749	DETAILS
C750	DETAILS
C751	DETAILS
C752	DETAILS
C753	DETAILS
C754	DETAILS
C755	DETAILS
C756	DETAILS
C757	DETAILS
C758	DETAILS
C759	DETAILS
C760	DETAILS
C761	DETAILS
C762	DETAILS
C763	DETAILS
C764	DETAILS
C765	DETAILS
C766	DETAILS
C767	DETAILS
C768	DETAILS
C769	DETAILS
C770	DETAILS
C771	DETAILS
C772	DETAILS
C773	DETAILS
C774	DETAILS
C775	DETAILS
C776	DETAILS
C777	DETAILS
C778	DETAILS
C779	DETAILS
C780	DETAILS
C781	DETAILS
C782	DETAILS
C783	DETAILS
C784	DETAILS
C785	DETAILS
C786	DETAILS
C787	DETAILS
C788	DETAILS
C789	DETAILS
C790	DETAILS
C791	DETAILS
C792	DETAILS
C793	DETAILS
C794	DETAILS
C795	DETAILS
C796	DETAILS
C797	DETAILS
C798	DETAILS
C799	DETAILS
C800	DRY UTILITY PLAN

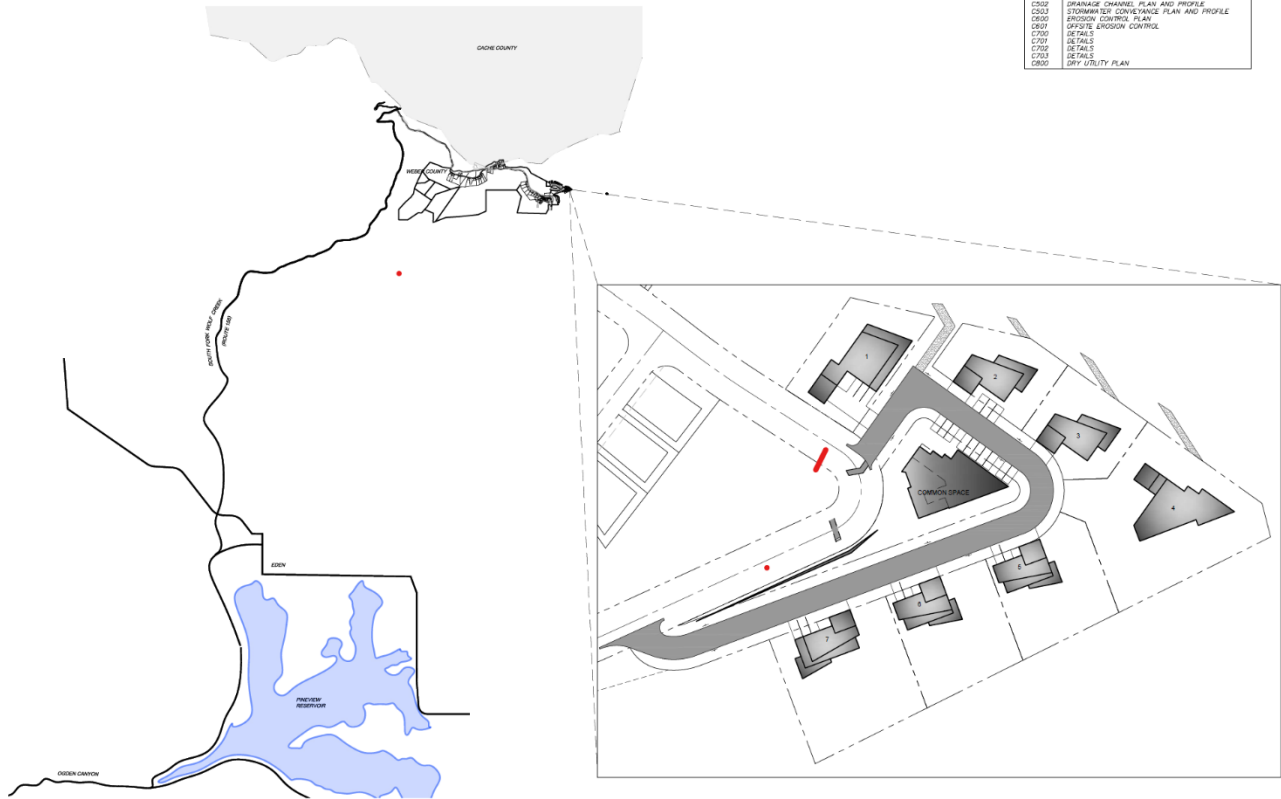

## SECTION 3: WATER QUALITY

### 3.1 Discharge Information

Does your project/site discharge storm water into a Municipal Separate Storm Sewer System (MS4)?  Yes  No

List the MS4 that receives the discharge from the construction project:  
 Weber County (Unincorporated Areas) MS4

### 3.2 Receiving Waters

#### Names of Receiving Waters

Name of Receiving Water (first surface water that receives storm water or where storm system discharges to)	Is the water impaired or high quality?	If high quality: Is it Category 1 or 2?  If impaired: List pollutants that the waterbody is impaired for
1. Middle Fork 2. Ogden River	<input type="checkbox"/> Not high quality/impaired <input type="checkbox"/> Impaired, has approved TMDL <input type="checkbox"/> Impaired, no TMDL <input checked="" type="checkbox"/> High quality	
3.	<input type="checkbox"/> Not high quality/impaired <input type="checkbox"/> Impaired, has approved TMDL <input type="checkbox"/> Impaired, no TMDL <input type="checkbox"/> High quality	

[Insert or delete rows as necessary.]

### 3.3 Impaired Waters

This site will not discharging into impaired waters

### **3.4 High Water Quality**

Description of additional precautions taken to minimize pollution effects if you are discharging to a high-quality surface water:

Not Applicable – The site will not be discharging surface water into waters of the state.



## SECTION 4: POLLUTION PREVENTION STANDARDS

### 4.1 Potential Sources of Pollution

Pollutant-Generating Activity	Pollutants or Pollutant Constituents									Location on Site
	Sediment	Nutrients	Heavy Metals	pH	Pesticides/Herbicides	Petroleum Products	Micro Organisms	Trash/Debris	Other Toxic Chemicals	
Clearing, Grading, Excavating	X							X		See SWPPP Site Map/Project Manual
Paving	X							X		See SWPPP Site Map/Project Manual
Concrete Washout			X	X				X		See SWPPP Site Map/Project Manual
Construction, Painting, Cleaning		X		X				X	X	See SWPPP Site Map/Project Manual
Demolition, Disposal	X							X		See SWPPP Site Map/Project Manual
Dewatering	X	X								See SWPPP Site Map/Project Manual
Drilling /Blasting	X			X				X		See SWPPP Site Map/Project Manual
Material Delivery/Storage	X	X	X	X	X	X		X	X	See SWPPP Site Map/Project Manual
Hazardous Waste			X	X	X	X			X	See SWPPP Site Map/Project Manual
Contaminated Spills		X	X	X	X	X			X	See SWPPP Site Map/Project Manual
Septic Waste		X		X			X		X	See SWPPP Site Map/Project Manual
Equipment's Fueling/Maintenance/Storage						X			X	See SWPPP Site Map/Project Manual
Landscaping	X	X						X		See SWPPP Site Map/Project Manual
Trash and Debris								X	X	See SWPPP Site Map/Project Manual

## 4.2 Non-Storm Water Discharges

Check allowable non-storm water discharges that are present and describe the measures used to reduce them or prevent them from contributing pollutants to discharges:

Authorized Non-Storm Water Discharges	Present	Comments/Controls
Discharges from emergency fire-fighting activities	<input type="checkbox"/> Y <input checked="" type="checkbox"/> N	None are anticipated
Fire hydrant flushing	<input type="checkbox"/> Y <input checked="" type="checkbox"/> N	No hyper-chlorinated water discharges (from water lines disinfection) will be allowed in the storm drain. Prior arrangements must be made with the Sanitary Sewer Treatment Facility before high-chlorine water is flushed in to the sanitary sewer.
Properly managed landscape irrigation (excludes fertilizer injector systems)	<input checked="" type="checkbox"/> Y <input type="checkbox"/> N	water discharges will be allowed in the storm drain
Properly managed vehicle and equipment wash water with no soaps, solvents, or detergents	<input type="checkbox"/> Y <input checked="" type="checkbox"/> N	Concrete trucks are rinsed on the site without the use of detergents. Washout water is retained on the site.
Water used to control dust	<input checked="" type="checkbox"/> Y <input type="checkbox"/> N	water discharges will be allowed in the storm drain
Drinking water, includes uncontaminated water line flushing	<input checked="" type="checkbox"/> Y <input type="checkbox"/> N	Not on site
External building washdown with no soaps, solvents, detergents, or hazardous substances	<input checked="" type="checkbox"/> Y <input type="checkbox"/> N	Not on site
Pavement wash waters with no detergents or toxic or hazardous materials. Must have a sediment basin, sediment trap, or similarly effective control prior to discharge.	<input type="checkbox"/> Y <input checked="" type="checkbox"/> N	water discharges will be allowed in the storm drain – though not anticipated on the site
Uncontaminated air conditioning or compressor condensate	<input type="checkbox"/> Y <input checked="" type="checkbox"/> N	Not on site
Uncontaminated, non-turbid discharges of ground water (from natural sources) or spring water	<input type="checkbox"/> Y <input checked="" type="checkbox"/> N	Not on site
Uncontaminated foundation or footing drains	<input type="checkbox"/> Y <input checked="" type="checkbox"/> N	Not on site

### 4.3 Dewatering Practices

Check box if section not applicable to this site

#### General

- Dewatering from building footings or other construction site sources should not be discharged without treatment. Also, turbid water should be filtered or allowed to settle before being discharged from the site.

#### Specific Dewatering Practices

##### Dewatering Practice # 1

- Dewatering activities are not expected to occur at the project site. Dewatering will be as needed if the groundwater table needs to be lowered, for construction sites to remain dry, or until all utility ditches or cofferdams are no longer needed. When dewatering BMPs are installed on the project site, locations should be documented on the SWPPP drawing.

#### Installation

- Assure that the dewatering discharge does not cause scouring of the receiving area. Base the design of any structural BMPs (i.e., basins or sumps) that are to receive dewatering discharge on the anticipated flow rate from the dewatered area.
- Prior to discharging to any surface water, pump sediment-laden water from any areas being dewatered through a geotextile material filter bag.
- List Dates this method was utilized: N/A

#### Maintenance Requirements

- With backwash water, either haul it away for disposal or return it to the beginning of the treatment process; and replace and clean the filter media used in dewatering devices when the pressure differential equals or exceeds the manufacturer's specifications.

#### Responsible Staff

- Assigned by GENEVA ROCK PRODUCTS

## 4.4 Natural Buffers or Equivalent Sediment Controls

### Instructions (CGP Part 7.3.5.b.(1), 2.2.1, and Appendix A):

This section only applies if a surface water is located within 50 feet your construction activities. If this is the case, review CGP Part 2.2.1. and Appendix A of the CGP for information on how to comply with the buffer requirements.

- Describe the compliance alternative that was chosen to meet the buffer requirements, and include any required documentation supporting the alternative selected. The compliance alternative selected must be maintained throughout the duration of permit coverage. However, if you select a different compliance alternative during your period of permit coverage, you must modify your SWPPP to reflect this change.
- If you qualify for one of the exceptions in CGP Part A.2.2., include documentation related to your qualification for such exceptions.
- Review Appendix A of the CGP for step-by-step instructions and examples on how to comply with the different buffer alternatives.

### Buffer Compliance Alternatives

Are there any surface waters within fifty feet of your project's earth disturbances?

YES     NO

(Note: If "no", no further documentation is required.)

## **SECTION 5: EROSION AND SEDIMENT CONTROLS – BMPS**

### **5.1 *List of Erosion and Sediment BMPs on Site***

<b>CGP Requirement</b>	<b>BMPs</b>	<b>EPA SWPPP Guide Section</b>	<b>BMPs Selected</b>
Preserve vegetation where possible and direct storm water to vegetated areas when feasible (CGP 2.2.2.)	Phasing to minimize disturbance, signs/fences to protect areas not being disturbed.	Chapter 4, ESC Principal 1	Silt fencing
Install sediment controls along perimeter areas that receive pollutant discharges (CGP 2.2.3.).	Silt fence, fiber rolls, earth berms	Chapter 4, ESC Principle 7	Silt fence as needed
Minimize sediment track-out (CGP 2.2.4.)	Restrict access, stabilize exits, track-out pads, tire washing station, clean-up sediments	Chapter 4, ESC Principle 9	Truck out pad, restricted access
Manage stockpiles with perimeter controls and locate away from storm water conveyances (CGP 2.2.5.)	Sediment barriers downgradient, proper location, covered stockpiles, diverting storm water from stockpiles	Chapter 4, ESC Principle 4	Stockpile location
Minimize dust (CGP 2.2.6.)	Water application, mulching, chemical dust suppression techniques		Water truck application
Minimize steep slope disturbance (CGP 2.2.7.)	Erosion control blankets, tackifiers, protect slopes from disturbance	Chapter 4, ESC Principle 5	Not applicable to site
Preserve topsoil (CGP 2.2.8.)	Stockpile topsoil	Chapter 4, ESC Principle 1	Stockpile location
Minimize soil compaction where final cover is vegetation (CGP 2.2.9.)	Restrict vehicle access, precondition soils before seeding		Not applicable to site
Protect storm drain inlets (CGP 2.2.10.)	Inserts, rock-filled bags, covers	Chapter 4, ESC Principle 6	Inlet barriers
Slow down runoff with erosion controls and velocity dissipation devices (CGP 2.2.11.)	Check dams, riprap	Chapter 4, ESC Principle 3	Not applicable to site
Appropriately design any sediment basins or impoundments (CGP 2.2.12.)	Design to 2-year 24-hour storm or 3,600 cubic feet per acre drained, include design specifications	Chapter 4, ESC Principle 8	
Follow requirements for any treatment chemicals (polymers, flocculants, coagulants, etc.)	Store in leak proof containers and cover, proper training, minimize use		Proper storage of chemicals
Stabilize exposed portions of site with 14 days of inactivity (CGP 2.2.14).	Seeding, erosion control blankets, gravel, hydro mulch	Chapter 9	Seeding as required

### **5.1.1 Minimize Disturbed Area and Preserve Vegetation and Soil**

The Silver Creek to Bitner Connector construction project will be protected along the borders of the site, as needed, to minimize the disturbance of soil for properties surrounding the site. There are no unique features to be preserved at the project site.

If available provide and maintain undisturbed natural vegetation of fifty feet for a sediment load reduction it can also be supplemented by additional erosion and sediment controls.

---

#### **5.1.1: Preserve vegetation**

---

##### ***BMP Description/Instructions:***

<b><i>Installation Schedule:</i></b>	
<b><i>Maintenance and Inspection:</i></b>	
<b><i>Responsible Staff:</i></b>	
<b><i>Design Specifications and Drawings:</i></b>	

### 5.1.2 Establish Perimeter Controls and Sediment Barriers

Before being discharged from the construction site, sediment-contaminated storm water will be filtered through silt fencing along the borders of the project site.

#### Specific Perimeter Controls Perimeter Control # 1

- Silt fence will be installed along the perimeters of the site and around any topsoil stockpile. Silt fences will be installed by excavating a 6 to 8-inch-deep trench along the line of proposed installation. Wooden posts supporting the silt fence will be spaced six feet apart and driven securely into the ground; a minimum of 18 to 20 inches deep. The silt fence will be fastened securely to the wooden posts with staples or zip-ties spaced every twelve inches at the top, mid-section, and bottom of the wooden post. The bottom edge of the silt fence will extend across the bottom of the trench and the trench will be backfilled and compacted to prevent stormwater and sediment from discharging underneath the silt fence.

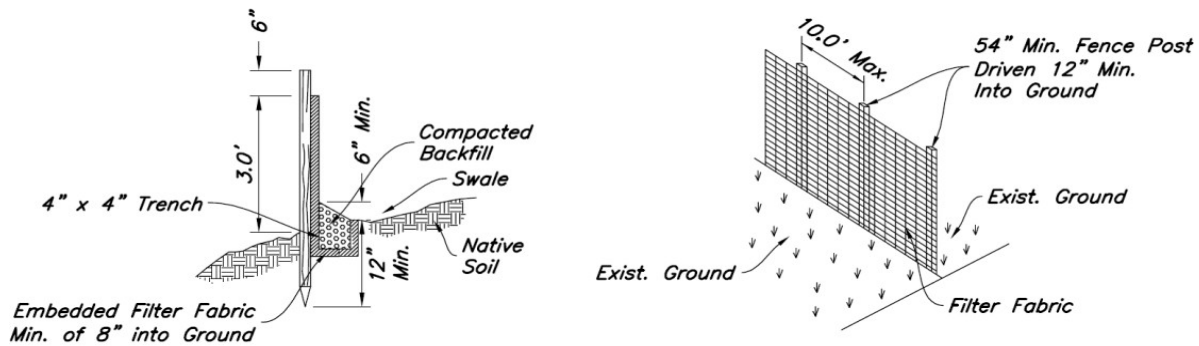

Posts: Steel Either T or U Type or 2"x2" Hardwood  
Filter Fabric: 1. MIRAFI 140N  
2. Dupont TYPAR 3341  
3. or Approved Equal

#### Notes:

1. Filter cloth to be fastened securely to fence posts with wire ties or staples.
2. When two sections of filter cloth adjoin each other they shall be overlapped by six inches and folded.
3. Collected material shall be removed when "bulges" develop in the silt fence.

#### Installation

- Silt fences will be installed before construction begins and around topsoil stockpiles when they have been established.
- List Dates this method was utilized:

#### Maintenance Requirements

- The silt fence will be maintained on a regular basis and before it has accumulated sediment to one-half of the above-ground height. If gaps or tears are found during the inspection, the fabric will be repaired or replaced immediately.
- 

Responsible Staff: Assigned by GENEVA ROCK PRODUCTS



### 5.1.3 Establish Stabilized Construction Exits

A construction exit will be located on west end of the project site. All construction vehicles exiting the site will be limited to this access. The access will be stabilized with quarry spalls, crushed rock, or asphalt to prevent tracking sediment onto either road and/or into the gutters. As the construction phasing progresses the construction access may be relocated to accommodate the construction process.

#### Specific Track-Out Controls Track-Out Control # 1 Track-Out Control Description

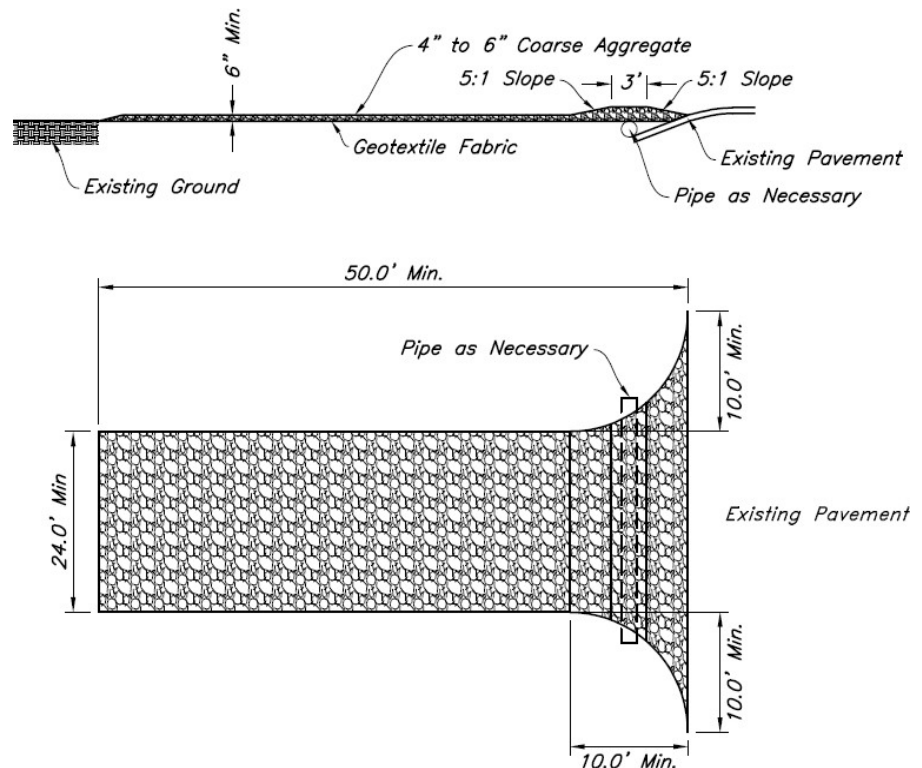

#### Installation

- Truck-out will be constructed before construction begins.
- List Dates this method was utilized:

#### Maintenance Requirements

- Maintenance of the truck-out should occur as needed when sediment has been tracked-out from the site onto the surface of off-site streets, other paved areas, and sidewalks. The Sediment must be removed the end of the same workday in which the track-out occurs or by the end of the next workday if track-out occurs on a non-workday. The sediment can be removed by sweeping, shoveling, or vacuuming these surfaces, or by using other similarly effective means of sediment removal. It is prohibited to remove the sediment by hosing or sweeping it into any stormwater conveyance (unless it is connected to a sediment basin, sediment trap, or similarly effective control), storm drain inlet, or surface water.

Responsible Staff: Assigned by GENEVA ROCK PRODUCTS

## 5.1.4 Stockpiled Soil or Other Erodible Material

### Stockpiled Sediment Control # 1

#### Perimeter Control Description

- Silt fence will be installed along the around any topsoil stockpile. Silt fences will be installed by excavating a 6 to 8-inch-deep trench along the line of proposed installation. Wooden posts supporting the silt fence will be spaced six feet apart and driven securely into the ground; a minimum of 18 to 20 inches deep. The silt fence will be fastened securely to the wooden posts with staples or zip-ties spaced every twelve inches at the top, mid-section, and bottom of the wooden post. The bottom edge of the silt fence will extend across the bottom of the trench and the trench will be backfilled and compacted to prevent stormwater and sediment from discharging underneath the silt fence.

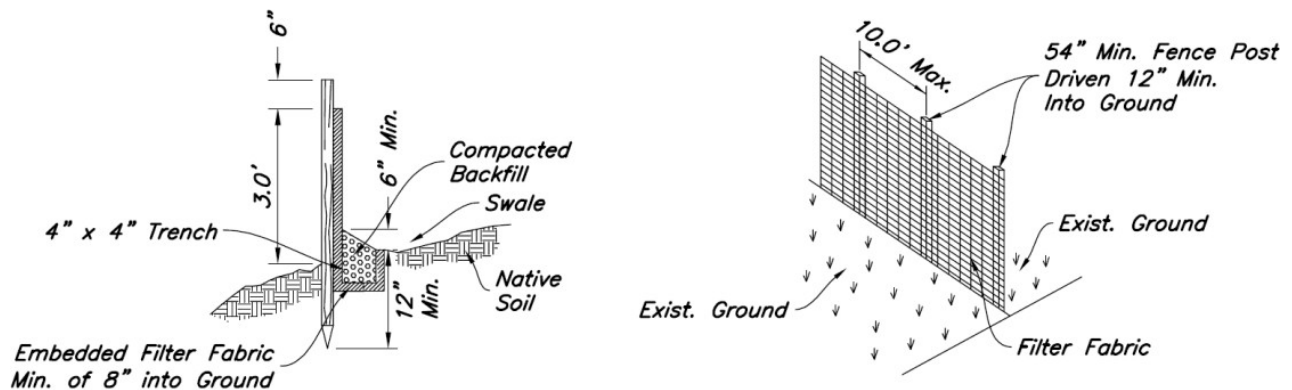

Posts: Steel Either T or U Type or 2"x2" Hardwood

Filter Fabric: 1. MIRAFL 140N  
2. Dupont TYPAR 3341  
3. or Approved Equal

#### Notes:

1. Filter cloth to be fastened securely to fence posts with wire ties or staples.
2. When two sections of filter cloth adjoin each other they shall be overlapped by six inches and folded.
3. Collected material shall be removed when "bulges" develop in the silt fence.

#### Installation

- This method will not be utilized on the project.

#### Maintenance Requirements

- If gaps or tears are found during the inspection, the fabric will be repaired or replaced immediately.

#### Responsible Staff

- Assigned by GENEVA ROCK PRODUCTS

## 5.1.5 Minimize Dust

### General

The owner, operator, and contractors responsible for dust control at a site will have to determine which practices accommodate their needs according to the site and weather conditions of the area. Dust control will be implemented as needed once site grading has begun and during windy conditions (forecasted or actual wind conditions of 20 mph or greater) while site grading is occurring.

### Specific Dust Controls

#### Dust Control # 1

- Sprinkling/Irrigation. Spraying of potable water at a rate of three hundred gallons per acre ~~less~~ can be performed by a mobile pressure-type distributor truck no more than three times a day during the months of May–July and once per day during the months of August–October or whenever the dryness of the soil warrants it.

#### Installation

- List Dates this method was utilized:

#### Dust Control # 2

- Mulch. Hydro mulching options can be utilized for a quick and effective means of dust control may be wood fiber, straw, or a soil tackifier. This can be performed by a mobile pressure-type distributor truck using potable water at a rate specified by product manufacturer.

#### Installation

- List Dates this method was utilized:

#### Maintenance Requirements

- Reapply dust control when soil dries, and dust begins to form.

#### Responsible Staff

Assigned by GENEVA ROCK PRODUCTS

## 5.1.6 Protect Slopes

### General

- Cut and fill slopes on this project have been designed and will be constructed to minimize erosion. In addition, slope runoff velocities can be reduced by terracing, creating diversions, installing erosion control blankets and surface contouring.
- No change will be made to the grade surrounding the project.
- Steep slopes have not been noted on this project.

### Specific Steep Slope Controls

#### Steep Slope Control # 1

- Erosion control blankets will be used to provide stabilization for the slopes greater than 2:1 or to stabilize ditches. The blanket will cover the entire area of the graded slope and bottom channel. The bottom and side slopes will be seeded and mulched before the blanket is applied. The blanket will be installed by digging a small trench on the upside of the slope, six inches deep, and stapling the leading edge of the blanket in the trench. The blanket will be rolled down the slope slowly to maintain soil contact and stapled in intervals according to the manufacturer's recommendation. The erosion control blanket will always be installed according to the manufacturer's instructions and specifications.

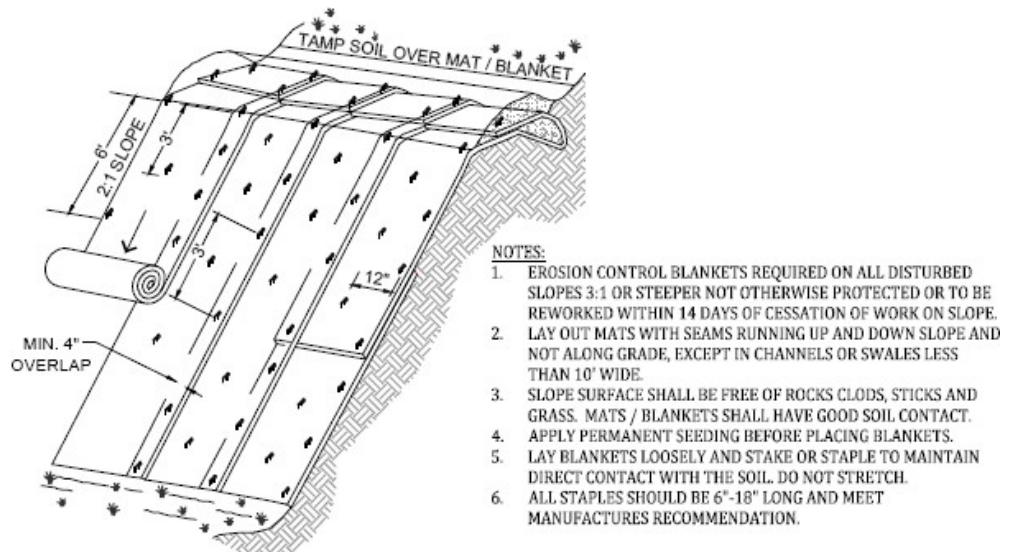

### Installation

- List Dates this method was utilized:

### Maintenance Requirements

- The erosion control blanket will be inspected until vegetation is established to determine if cracks, tears, or breaches have formed in the fabric; if so, the blanket will be repaired or replaced immediately.

Responsible Staff: Assigned by GENEVA ROCK PRODUCTS

### 5.1.7 Stockpiled Soil or Other Erodible Material

#### Stockpiled Sediment Control # 1

##### Perimeter Control Description

- Silt fence will be installed along the around any topsoil stockpile. Silt fences will be installed by excavating a 6 to 8-inch-deep trench along the line of proposed installation. Wooden posts supporting the silt fence will be spaced six feet apart and driven securely into the ground; a minimum of 18 to 20 inches deep. The silt fence will be fastened securely to the wooden posts with staples or zip-ties spaced every twelve inches at the top, mid-section, and bottom of the wooden post. The bottom edge of the silt fence will extend across the bottom of the trench and the trench will be backfilled and compacted to prevent stormwater and sediment from discharging underneath the silt fence.

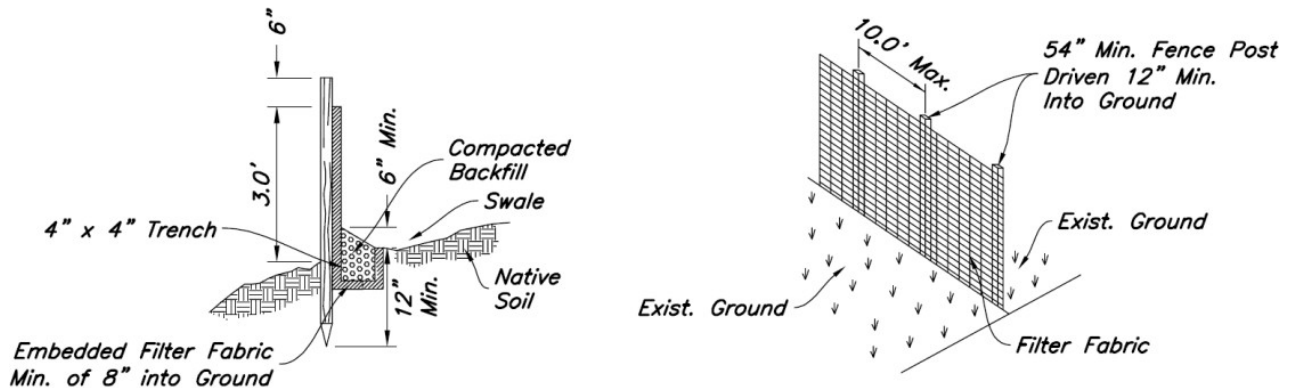

Posts: Steel Either T or U Type or 2"x2" Hardwood  
Filter Fabric: 1. MIRAFL 140N  
2. Dupont TYPAR 3341  
3. or Approved Equal

##### Notes:

1. Filter cloth to be fastened securely to fence posts with wire ties or staples.
2. When two sections of filter cloth adjoin each other they shall be overlapped by six inches and folded.
3. Collected material shall be removed when "bulges" develop in the silt fence.

##### Installation

- This method will not be utilized on the project.

##### Maintenance Requirements

- If gaps or tears are found during the inspection, the fabric will be repaired or replaced immediately.

##### Responsible Staff

- Assigned by GENEVA ROCK PRODUCTS

### **5.1.8 Soil Compaction**

#### **General**

- In areas where final vegetative stabilization will occur, heavy construction traffic will be kept to a minimum.

#### **Specific Soil Compaction Controls**

##### Soil Compaction Control # 1

- The project manager of the site will determine the method of traffic control in these areas. Several methods available to be utilized include 48" orange safety fence, safety cones, temporary construction fencing, or any other method which proves effective.

##### Installation

- This method will not be utilized on the project.

##### Maintenance Requirements

- Maintenance will be completed on an "as needed" basis and may include repairing, replacing, or moving the controls to maintain effectiveness.

##### Responsible Staff

- Assigned by GENEVA ROCK PRODUCTS

## 5.1.9 Protect Storm Drain Inlets

### General

- Existing storm drain inlets will be protected to prevent storm water from entering without first being filtered or treated to remove sediment. All storm drain inlets made operable during construction will be protected to prevent storm water from entering without first being filtered or treated to remove sediment. The Protection devices will be removed once the construction site has been permanently stabilized.

### Specific Storm Drain Inlet Controls

#### Storm Drain Inlet Control # 1

- Work covered under this item consists of installing an inlet protection system. The purpose is to keep silt, sediment and construction debris out of the storm water system.

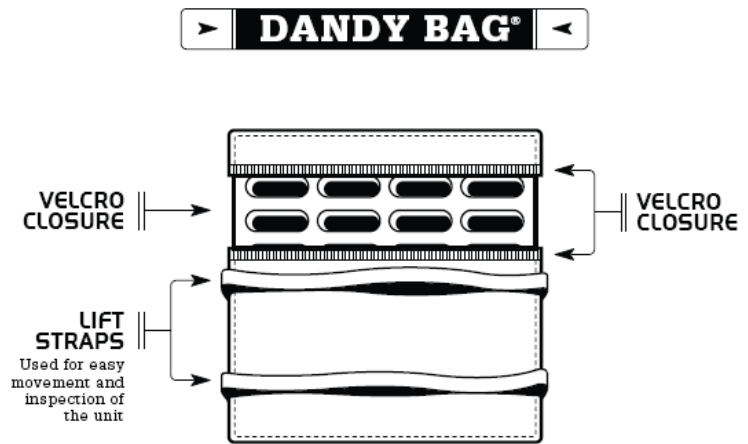

### Installation

- Existing inlets will be protected before construction activities begin on-site. New inlets will be protected when installation is completed.
- List Dates this method was utilized:

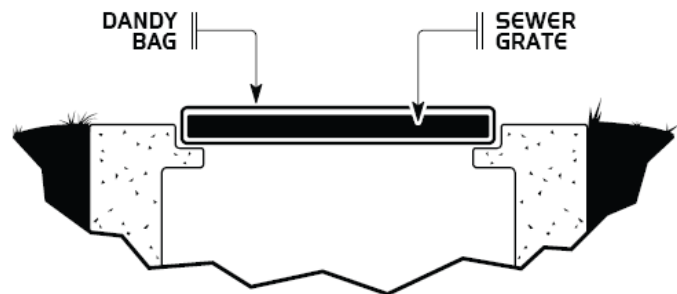

### Maintenance Requirements

- Clean, or remove and replace, the protection measures as sediment accumulates, the filter becomes clogged, and/or performance is compromised. Where there is evidence of sediment accumulation adjacent to the inlet protection measure, you must remove the deposited sediment by the end of the same workday in which it is found or by the end of the following workday if removal by the same workday is not feasible.

### Responsible Staff

- Assigned by GENEVA ROCK PRODUCTS

## 5.1.10 Control Storm Water Flowing onto and through the Project

### General

- Check dams help reduce ditch and channel velocities, prevent erosion, and trap small amounts of sediment by intercepting flow along a ditch or channel. The disruption in flow direction and speed creates low velocity areas on the upgradient side of the check dam, causing deposition of heavier sediment particles and resulting in reduced scour potential (i.e., lateral and vertical erosion). Under low-flow conditions, water ponds behind the structure and then slowly drains through, infiltrates, or evaporates. Under high-flow conditions, water flows over and/or through the structure. The main function of a check dam is to decrease velocity, not to collect sediment, although sediment capture and increased infiltration is an added benefit.

### Specific Stormwater Control

#### Stormwater Flow Practice # 1

- Check Dam – Fiber Roll: Stormwater Control activities are expected to occur at the project site.

#### Installation

- The check dam will be installed after site grading operations begin at the construction site.
- This method will not be utilized on the project.

#### Maintenance Requirements:

- The swale will be inspected for erosion and structural failures weekly and immediately after storm events. Before vegetation has been established in the swale, it will be inspected for erosion and accumulation of debris and sediment. Remove debris, sediment, and repair erosion and embankments immediately.

Responsible Staff: Assigned by GENEVA  
 ROCK PRODUCTS

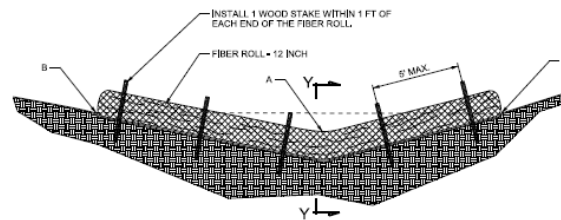
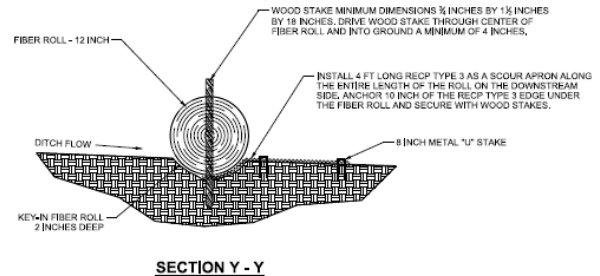

**ELEVATION**  
**CHECK DAM - FIBER ROLL**

MATERIAL QUANTITY CHART		
DITCH SIDE SLOPE	LENGTH (FT) OF 12 INCH DIAMETER FIBER ROLL REQUIRED FOR HALF OF DITCH	CUBIC YARDS OF STONE REQUIRED FOR HALF OF DITCH
2:1	2.5	0.17
3:1	3.5	0.24
4:1	4.7	0.31
6:1	7.0	0.45
8:1	9.4	0.60
10:1	11.7	0.75
12:1	14	0.90

EXAMPLE: A CUT DITCH WITH A 6:1 FORE SLOPE AND A 2:1 BACK SLOPE WOULD REQUIRE A 9.5 (7.0 + 2.5) FT MIN. FIBER ROLL OR 0.62 (0.45 + 0.17) CUBIC YARD MIN. OF STONE.



### **5.1.11 Retain Sediment On-Site**

#### **General**

- Sediment basins or ponds can be used to capture sediment from stormwater runoff before it leaves a construction site and allows a pool to form in an excavated or natural depression, where sediment can settle. The pool is dewatered through a single riser and drainage hole leading to a suitable outlet on the downstream side of the embankment or through the gravel of a rock dam. The water is released more slowly than it would be without the control structure.

#### **Specific Sediment Basin Controls**

- A sediment basin is constructed by excavation or by erecting an earthen embankment across a low area or drainage swale. The basin can be temporary (up to 3 years) or permanent. Construct the basins before any grading takes place in the drainage area. For permanent structures, a qualified professional engineer experienced in designing dams should complete the basin design.
- Limit sediment basins with rock dams to a drainage area of fifty acres. Limit the rockdam height to eight feet with a top width of at least five feet. Side slopes for rock dams should be no steeper than 2:1 on the basin side of the structure and 3:1 on the outlet side. Cover the basin side of the rock dam with fine gravel from top to bottom for at least one foot. This slows the drainage rate from the pool that forms and gives sediments time to settle. The detention time should be at least 8 hours.
- Outfit sediment basins with earthen embankments with a dewatering pipe riser set just above the sediment removal cutoff level. Place the riser pipe at the deepest point of the basin and make sure it extends no farther than one foot below the level of the earthen dam. Place a water-permeable cover over the primary dewatering riser pipe to prevent trash and debris from entering and clogging the spillway.

#### **Installation**

- This method will not be utilized on the project.

#### **Maintenance Requirements**

- Inspect basins after each storm event to ensure proper drainage from the collection pool and determine the need for structural repairs. Replace material eroded from earthen embankments or stones moved from rock dams immediately. Locate sediment basins in an area that is easily accessible to maintenance crews for removal of accumulated sediment. Remove sediment from the basin when the storage capacity has reached approximately 50 percent. Remove trash and debris from around dewatering devices promptly after rainfall events.

#### **Responsible Staff**

- Assigned by GENEVA ROCK PRODUCTS

## 5.1.12 Construction and Domestic Waste

### Construction and Domestic Waste

- Subcontractors are responsible for the daily cleanup and disposal of building materials. For more specific responsibilities see project manual.

### Specific Pollution Prevention

#### Practices *Pollution Prevention*

##### Practice # 1 Description

- All waste materials will be collected and disposed of into metal trash dumpsters in the materials storage area. Dumpsters will be placed away from stormwater conveyances and drains, and meet all federal, state, and municipal regulations. Only trash and construction debris from the site will be deposited in the dumpster. No construction materials will be buried on-site. All personnel will be instructed, during tailgate training sessions, regarding the correct disposal of trash and construction debris. The individual who manages day-to-day site operations will be responsible for seeing that these practices are followed by the contractor and sub-contractors.

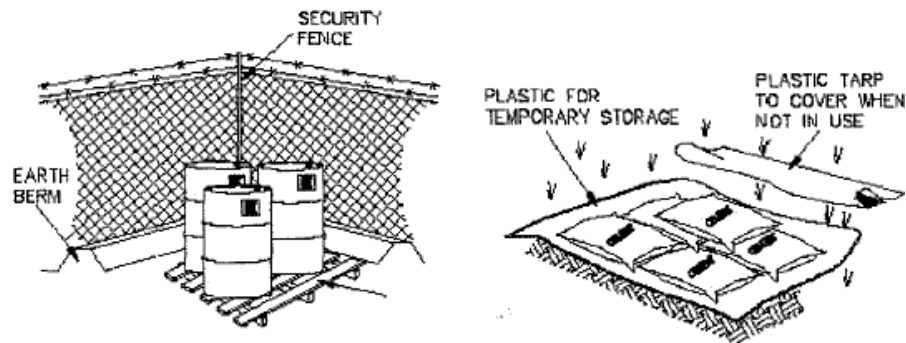

- ▶ CONTROLLED STORAGE LOCATION
- ▶ BERMED PERIMETER IMPOUNDMENT
- ▶ STORAGE OFF GROUND
- ▶ COVER WHEN NOT IN USE

### Installation

- Dumpsters will be installed as soon as materials storage area has been completed.

### Maintenance Requirements

- The dumpsters will be inspected and emptied on a regular schedule set by the project manager. If trash and construction debris are exceeding the dumpster's capacity, the dumpsters will be emptied more frequently.

### Responsible Staff

- Assigned by GENEVA ROCK PRODUCTS

### Sanitary Waste

- Sanitary waste must be properly managed and disposed of to reduce the risk of pollution from chemicals and microorganisms found in sanitary waste. Practices such as proper handling and spill prevention and cleanup measures can reduce the potential for contamination of surface or ground water.

### Specific Pollution Prevention Practices

#### Pollution Prevention Practice #1

##### Description

- Portable toilets will be provided at the site throughout the construction phase. The toilets will be in the staging area. The portable toilets will be located away from concentrated flow paths and traffic flow. They will be secured to the ground with rebar stakes and will have collection pans underneath as secondary containment.

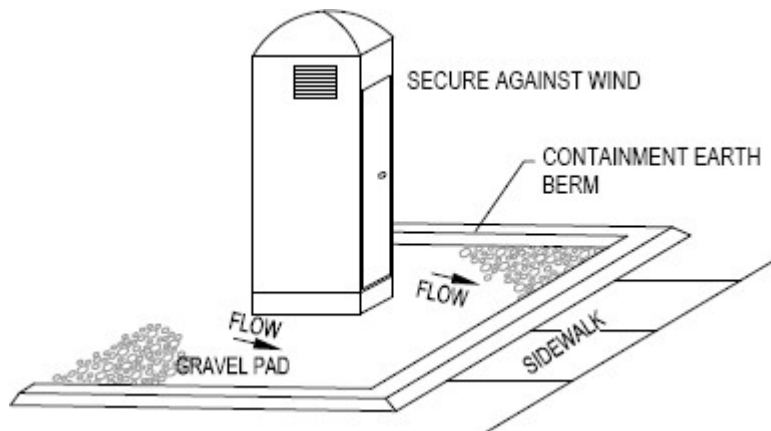

##### Installation

- Portable toilets will be installed as soon as materials staging area has been completed.

##### Maintenance Requirements

- The toilets will be inspected and emptied or replaced on a regular schedule set by the project manager. If needed, the toilets will be emptied or replaced more frequently.

##### Responsible Staff

- Assigned by GENEVA ROCK PRODUCTS

### 5.1.13 Stabilize Soils

Description of Practice

- Stabilization of fine graded disturbed areas using a continuous cover of grass sod.

**Specific Topsoil Controls**

Topsoil Control # 1

Residential or commercial areas where quick establishment or aesthetics are factors

Installation

- Only use sod harvested, delivered, and installed within the same 48-hour period.
- Do not place sod in extreme temperatures.
- Prior to temporary or final sod placement, fine grade the base soil.
- The first row of sod shall be laid in a straight-line perpendicular to the slopes with remaining rows placed parallel to and butted tightly against each other.
- Lateral joints shall be staggered to promote more uniform growth and strength.
- List Dates this method was utilized:

Maintenance Requirements

- Limit foot traffic to low use for the first two to three weeks.
- Ensure irrigation rate does not result in runoff.
- Install salt-tolerant sod where needed.
- Replace when >25% of any individual piece of sod is no longer viable.
- Restore areas where rolling edges are present, or sod is displaced.

Responsible Staff

- Assigned by GENEVA ROCK PRODUCTS

5.1.14: (Place name of BMP here – reference to detailed instructions in Appendix H if necessary)

***BMP Description/Instructions:***

<b><i>Installation Schedule:</i></b>	
<b><i>Maintenance and Inspection:</i></b>	
<b><i>Responsible Staff:</i></b>	
<b><i>Design Specifications and Drawings:</i></b>	

[Repeat as needed]

## 5.2 Linear Site Perimeter Control Exemption

Check box if section not applicable to this site not feasible, describe other practices in use:

## 5.3 Final Stabilization

Description of final stabilization practices and schedule:

### Description of Practice

- Permanent stabilization will be done immediately after the final design grades are achieved but no later than 14 days after construction ceases. Permanent stabilization will be completed in accordance with the final stabilization procedures on the landscaping plan pages.
- Permanent vegetation such as turf sod, trees, shrubs, perennials and grasses will be established after the final phase of construction; however, mulch, hydro seeding, or other means of soil coverage may be used to protect exposed soil for temporary stabilization.
- Design Specifications can be located on the landscape plan pages.

### Installation

- The dry season for northern Utah generally begins in June but can start as late as the beginning of July. The second week in September signals the end of the dry season and the beginning of the Monsoon season.
- List dates of installation:
- Approximate completion date: 12/31/2023

### Maintenance Requirements

- Permanent landscape will be maintained by the owner or operator as a post construction BMP. Regular watering, pruning, fertilizing, and replacing of any diseased or dead vegetation will preserve effectiveness of permanent stabilization.

### Responsible Staff

- Assigned by GENEVA ROCK PRODUCTS

Type of stabilization (vegetation/landscaped, graveled, paved, etc.)	Location	Implementation Schedule

## SECTION 6: BMPS - POLLUTION PREVENTION/OPERATIONAL CONTROLS

### 6.1 *Spill Prevention and Response*

Identify the employee responsible for detection and response of spills and leaks:

The Superintendent and the Project Manager of the site will be responsible for spills and leaks.

Material safety data sheets, a material inventory, and emergency contact information will be maintained at the on-site project trailer.

- Potential pollutants will be stored and used in a manner consistent with the manufacturer's instructions in a secure location. To the extent practicable, material storage areas should not be located near storm drain inlets and should be equipped with covers, roofs, or secondary containment as needed to prevent storm water from contacting stored materials. Chemicals that are not compatible (such as sodium bicarbonate and hydrochloric acid) shall be stored in segregated areas so that spilled materials cannot combine and react.
- Materials disposal will be in accordance with the manufacturer's instructions and applicable local, state, and federal regulations.
- Materials no longer required for construction will be removed from the site as soon as practicable.
- Adequate garbage, construction waste, and sanitary waste handling and disposal facilities will be provided to the extent necessary to keep the site clear of obstruction and BMPs clear and functional.
- GENEVA ROCK PRODUCTS and the project superintendent will be responsible for spill prevention and response. Contact information is below:

Casey Harris, Project Manager  
Cell: 435-994-0619  
Email: [charris@genevarock.com](mailto:charris@genevarock.com)

#### **Specific Materials Handling Practices**

- All pollutants, including waste materials and demolition debris, that occur on-site during construction will be handled in a way that does not contaminate storm water.
- All chemicals including liquid products, petroleum products, water

treatment chemicals, and wastes stored on site will be covered and contained and protected from vandalism.

- Maintenance and repair of all equipment and vehicles involving oil changes, hydraulic system drain down, de-greasing operations, fuel tank drain down and removal, and other activities which may result in the accidental release of contaminants, will be conducted under cover during wet weather and on an impervious surface to prevent the release of contaminants onto the ground.

Materials spilled during maintenance operations will be cleaned up immediately and properly disposed of.

- Wheel wash water will be settled and discharged on site by infiltration. Wheel wash water will not be discharged to the storm water system or the storm water treatment system.
- Application of agricultural chemicals, including fertilizers and pesticides, will be conducted in a manner and at application rates that will not result in loss of chemical to storm water runoff. Manufacturers' recommendations will be followed for application rates and procedures.
- pH-modifying sources will be managed to prevent contamination of runoff and storm water collected on site. The most common sources of pH-modifying materials are bulk cement, cement kiln dust (CKD), fly ash, new concrete washing and curing waters, waste streams generated from concrete grinding and sawing, exposed aggregate processes, and concrete pumping and mixer washout waters.
- At least one concrete washout location will be provided and maintained on a regular basis for all concrete washout waters. These may include a detention basin, straw bale washout, washout dumpster, and so forth. The slurry will be disposed of according to the local ordinances of the city, county and/or state.

#### **Spill Response**

- The primary objective in responding to a spill is to quickly contain the material(s) and prevent or minimize their migration into storm water runoff and conveyance systems. If the release has impacted on-site storm water, it is critical to contain the released materials on site and prevent their release into receiving waters.
- If a spill of pollutants threatens storm water at the site, the spill response procedures outlined below must be implemented in a timely manner to prevent the release of pollutants.
- The site superintendent will be notified immediately when a spill, or the threat of a spill, is observed. The superintendent will assess the

- situation and determine the appropriate response.
- If spills represent an imminent threat of escaping ESC facilities and entering the receiving waters, facility personnel will respond immediately to contain the release and notify the superintendent after the situation has been stabilized.
  - Spill kits containing materials and equipment for spill response and cleanup will be maintained at the site. Each spill kit may contain:
    - Oil absorbent pads (one bale)
    - Oil absorbent booms (40 feet)
    - 55-gallon drums (2)
    - 9-mil plastic bags (10)
    - Personal protective equipment including gloves and goggles.

If oil sheen is observed on surface water (e.g., settling ponds, detention pond, swales), absorbent pads and/or booms will be applied to contain and remove the oil. The source of the oil sheen will also be identified and removed or repaired as necessary to prevent further releases.

- The site superintendent, or his designee, will be responsible for completing the spill reporting form and for reporting the spill to the appropriate state or local agency (see Forms at the end of this section).
- Facility personnel with primary responsibility for spill response and cleanup will receive training from the site superintendent. This training will include identifying the location of spill kits and other spill response equipment and the use of spill response materials.
- Spill response equipment will be inspected and maintained as necessary to replace any materials used in spill response activities.

Any discharges in 24 hours equal to or in excess of the reportable quantities listed in 40 CFR 117, 40 CFR 110, and 40 CFR 302 will be reported to the National Response Center and the Division of Water Quality (DWQ) as soon as practical after knowledge of the spill is known to the permittees. The permittee shall submit within 14 calendar days of knowledge of the release a written description of: the release (including the type and estimate of the amount of material released), the date that such release occurred, the circumstances leading to the release, and measures taken and/or planned to be taken to the Division of Water Quality (DWQ), 288 North 1460 West, P.O. Box 144870, Salt Lake City, Utah 84114-4870. The Storm Water Pollution Prevention Plan must be modified within 14 calendar days of knowledge of the release to provide a description of the release, the circumstances leading to the release, and the date of the release. In addition, the plan must be reviewed to identify measures to prevent the reoccurrence of



such releases and to respond to such releases, and the plan must be modified where appropriate.

Agency	Phone Number
National Response Center	(800) 424-8802
Division of Water Quality (DWQ) 24-Hr Reporting	(801)-231-1769 (801) 536-4123
Utah Department of Health Emergency Response	(801) 580-6681

Material	Media Released To	Reportable Quantity
Engine oil, fuel, hydraulic & brake fluid	Land	Twenty-five gallons
Paints, solvents, thinners	Land	100 lbs. (13 gallons)
Engine oil, fuel, hydraulic & brake fluid	Water	Visible Sheen
Antifreeze, battery acid, gasoline, engine degreasers	Air, Land, Water	100 lbs. (13 gallons)
Refrigerant	Air	1 lb.

## 6.2 Pollution Prevention Controls

### Instructions (CGP Part 2.3. and 7.3.5):

- Describe the key good housekeeping and pollution prevention (P2) BMPs that will be implemented to control pollutants in storm water (CGP Part 2.3).
- Use the below CGP requirements and the pollutant generating activities identified in SWPPP section 4.1. which were not addressed with the erosion and sediment BMPs to determine where BMPs are necessary.
- For each BMP you must provide a description of the control, any design specifications, routine maintenance specifications, a schedule for storm water control implementation/installation, and the staff responsible for maintaining the BMP.
- BMPs are listed as examples, you may use BMPs not listed.
- Details and design specifications can be provided in this section or in Appendix H.
- For more information, see *SWPPP Guide*, Chapter 5.
- Consult your state’s or local jurisdiction’s design manual or resources in Appendix D of the *SWPPP Guide*.
- For more information or ideas on BMPs, see EPA’s National Menu of BMPs  
<https://www.epa.gov/npdes/national-menu-best-management-practices-bmps-stormwater#constr>

<b>CGP Requirements</b>	<b>BMPs</b>	<b>EPA SWPPP Guide Section</b>	<b>BMPs Selected</b>
Equipment and vehicle fueling (CGP 2.3.1)	Spill kits, SPCCP, drip pans, locate activities away from conveyances, use secondary containment	Chapter 5, P2 Principle 4	Fueling Practices
Equipment and vehicle washing (CGP 2.3.2.)	Locating away from surface waters and storm water conveyances, directing wash waters to a sediment basin or sediment trap, using filtration devices	Chapter 5, P2 Principle 5	Washing Offsite
Storage, handling, and disposal of building products and waste (CGP 2.3.3.)	Cover (plastic sheeting / temporary roofs), secondary containment, leakproof containers, proper dumpsters, secured portable toilets, locate away from storm water conveyances	Chapter 5, P2 Principle 1 and 2	Storage Practices
Washing of stucco, paint, concrete, form release oils, curing compounds, etc. (CGP 2.3.4.)	Leak proof containers, lined pits, locate away from storm water conveyances	Chapter 5, P2 Principle 3	Washing Practices
Properly apply fertilizer (CGP 2.3.5)	Follow manufacture specifications, document deviations in applications, avoid applications to frozen ground, before heavy rains, or to storm water conveyances		Landscape

## **6.2.1 Establish Proper Equipment/Vehicle Fueling and Maintenance Practices**

### **General**

- Vehicles and equipment will be maintained off-site. All vehicles and equipment including subcontractor vehicles will be checked for leaking oil and fluids. Vehicles leaking fluids will not be allowed on-site. Drip pans will be placed under all vehicles and equipment that are parked overnight.

### **Specific Pollution Prevention Practices**

#### Pollution Prevention Practice # 1

##### Description

- Several types of vehicles and equipment will be used on-site throughout the project, including graders, scrapers, excavators, loaders, paving equipment, rollers, trucks and trailers, backhoes, and forklifts. All major equipment/vehicle fueling, and maintenance will be performed off-site. When vehicle fueling must occur on-site, the fueling activity will occur in the staging area. Only minor equipment maintenance will occur on-site. All equipment fluids generated from maintenance activities will be disposed of into designated drums stored on spill pallets. Absorbent, spill-cleanup materials, and spill kits will be available at the combined staging and materials storage area.

##### Installation

- BMPs implemented for equipment and vehicle maintenance and fueling activities will begin at the start of the project.

##### Maintenance Requirements

- Inspect equipment/vehicle storage area bi-weekly and after storm events. Vehicles and equipment will be inspected on a regular basis as laid out in the project manual. Leaks will be repaired immediately, or the problem vehicle(s) or equipment will be removed from the project site.

##### Responsible Staff:

- Assigned by GENEVA ROCK PRODUCTS

## **6.2.2 Control Equipment/Vehicle Washing**

### **General**

- All equipment and vehicle washing will be performed off-site.

Responsible Staff:

- Assigned by GENEVA ROCK PRODUCTS

## **6.2.3 Establish Proper Building Material Staging Areas**

### **General**

- Building material will be stored on site. They will be arranged in a way that will minimize the effect of contamination of storm water runoff. Material safety data sheets, material inventory, emergency contact numbers and complete HAZMAT Protocols for the project will be maintained in the office trailer.

### **Specific Pollution Prevention Practices**

#### Pollution Prevention Practice # 1

Description

- All hazardous waste materials such as oil filters, petroleum products, paint, and equipment maintenance fluids will be stored in structurally sound and sealed containers, within the hazardous materials storage area. Hazardous waste materials will be stored in appropriate and clearly marked containers and segregated from other non-waste materials. Secondary containment will be provided for all waste materials in the hazardous materials storage area and will consist of commercially available spill pallets. Additionally, all hazardous waste materials will be disposed of in accordance with federal, state, and municipal regulations. Hazardous waste materials will not be disposed of into the on-site dumpsters. All personnel will be instructed, during tailgate training sessions, regarding proper procedures for hazardous waste disposal. The individual who manages day-to-day site operations will be responsible for seeing that these procedures are followed.

Installation

- BMPs implemented for hazardous or toxic waste activities will begin at the start of the project.

Maintenance Requirements

- The hazardous waste material storage areas will be inspected bi-weekly and after storm events. The storage areas will be kept clean, well-organized, and equipped with ample cleanup supplies as appropriate for the materials being stored. Material safety data sheets, material inventory, and emergency contact numbers will be maintained in the office trailer.

Responsible Staff

- Assigned by GENEVA ROCK PRODUCTS

## 6.2.4 Washing of Applicators and Containers used for Concrete, Paint or Other Materials

### General

Responsible management of common chemicals such as solvents, paints, cleaners, and concrete can significantly reduce polluted runoff (WEF and ASCE, 1998). Such products (Cementitious: having the properties of cement; this type of wash water and solids also come from using such construction materials as mortar, plaster, stucco, and grout) must be handled properly in all stages of development, use, and disposal. Specific materials management can be found in the MSDS information located in the office trailer.

### Specific Pollution Prevention Practices

#### Pollution Prevention Practice # 1 Description

- A temporary washout will be constructed or installed on the site. The Project Manager will determine the washout method best suited for this project. The recommended minimum for a built-on site washout will be 10' square to contain all concrete and liquid waste from washout operations. The washout will be lined with a plastic membrane at least ten mils thick without any holes or tears. A sign will be posted at the washout site stating that it is the washout facility.

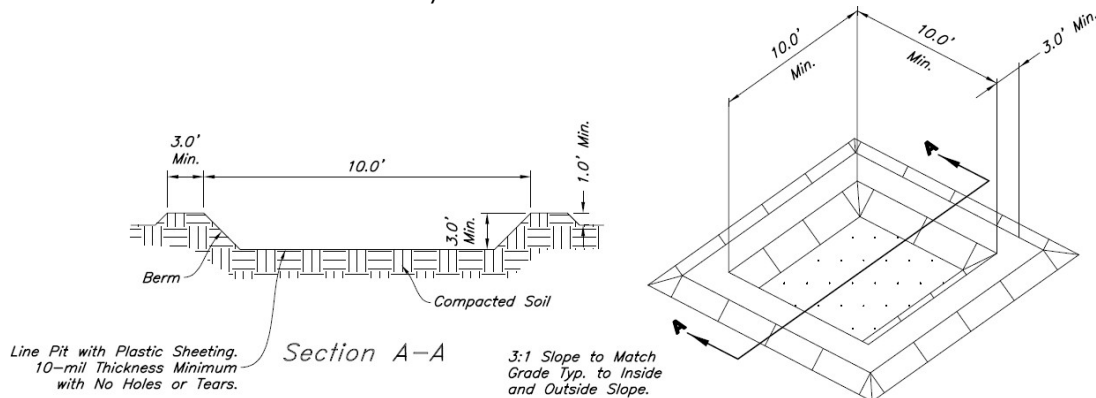

#### Installation

- The washout will be constructed/installed before any concrete pours are scheduled.

#### Maintenance Requirements

- The washout areas will be inspected daily by the site superintendent or project manager to ensure that all concrete washing is being discharged into the washout area, no leaks or tears are present, and to identify when concrete wastes need to be removed. The washout areas will be cleaned out once the area is filled to 75 percent of the holding capacity. Once the area's holding capacity has been reached, the wastes will be allowed to harden; the concrete will be broken up and disposed. The plastic sheeting will be replaced if tears occur during removal of concrete wastes from the washout area.

Responsible Staff: Assigned by GENEVA ROCK PRODUCTS

## 6.2.5 Pesticides, Herbicides, Insecticides, Fertilizers, and Landscape Materials

### General

- All landscaping materials will be kept off-site until final landscaping has been completed.

### Specific Pollution Prevention Practices

#### Pollution Prevention Practice # 1 Description

- All landscaping materials such as pesticides, herbicides, insecticides, and fertilizers will be stored in structurally sound and sealed containers, within the hazardous materials storage area. Landscaping materials will be stored in appropriate and clearly marked containers and segregated from other hazardous-waste materials. Additionally, all landscaping materials will be disposed of in accordance with federal, state, and municipal regulations. Landscaping waste materials will not be disposed of into the on-site dumpsters. The individual who manages day-to-day site operations will be responsible for seeing that these procedures are followed.

#### Installation

- BMPs implemented for pesticides, herbicides, insecticides, fertilizers, and landscape material activities will begin at the end of the project when landscaping begins.

#### Maintenance Requirements

- The hazardous waste material storage area will be inspected bi-weekly and after storm events. The storage areas will be kept clean, well-organized, and equipped with ample cleanup supplies as appropriate for the materials being stored. Material safety data sheets, material inventory, and emergency contact numbers will be maintained in the office trailer.

Responsible Staff:

Assigned by GENEVA ROCK PRODUCTS

---

6.2.6.: (Place name of BMP here – reference to detailed instructions in Appendix H if necessary)

---

#### ***BMP Description/Instructions:***

<b><i>Installation Schedule:</i></b>	
<b><i>Maintenance and Inspection:</i></b>	
<b><i>Responsible Staff:</i></b>	
<b><i>Design Specifications and Drawings:</i></b>	

[Repeat as needed]

## SECTION 7: SPECIAL CONDITIONS

### 7.1 Emergency Related Projects

Emergency-Related Project?  Yes  No

### 7.2 UIC Class 5 Injection Wells

**Instructions (CGP 7.3.8.):**

- If you are using any of the following storm water controls at your site as they are described below, you must document any contact you have had with DWQ for implementing the requirements for underground injection wells in the Safe Drinking Water Act and DEQ's implementing regulation at UAC R317-7.
- There may be additional local requirements related to such structures.
- For the State UIC Contact at DWQ call (801) 536-4300.

Check box if section not applicable to this site

Class V UIC Wells on site (all must be reported to DWQ for inventory):

- Infiltration trenches (if storm water is directed to any shaft or hole that is deeper than its widest surface dimension or has a subsurface fluid distribution system)
- Commercially manufactured pre-cast or pre-built subsurface detention vault/infiltration system
- Drywell, seepage pit, or improved sinkhole (if storm water is directed to any shaft or hole that is deeper than its widest surface dimension or has a subsurface fluid distribution system)

Description of your Class V Injection Well and any local requirements:

6.1 The owner or operator of any new injection well is required to obtain a permit from the Director prior to construction unless excepted by R317-7-6.3. Compliance with construction plans and standards is required prior to commencing injection operations. Changes in construction plans require approval of the Director.

6.2 Owners or operators of existing underground injection wells are required to obtain a permit from the Director unless specifically excepted by Section 7-6.3 of these rules.

6.3

A. Existing and new Class V injection wells are authorized by rule, subject to the conditions in Section 7-6.5 of these rules.

B. Well authorization under this Section 7-6.3 expires upon the effective date of a permit issued in accordance with these rules or upon proper closure of the well.

C. An owner or operator of a well which is authorized by rule under this Section 7-6.3 is prohibited from injecting into the well:

1. Upon the effective date of a permit denial.
2. Upon failure to submit a permit application in a timely manner if requested by the Director under Section 7-6.4 of these rules.
3. Upon failure to submit inventory information in a timely manner in accordance with Section 7-6.4(C) of these rules.

Description of any additional BMPs used in conjunction with the UIC well.

---

7.2.1: ([Place name of BMP here – reference to detailed instructions in Appendix H if necessary](#))

---

***BMP Description/Instructions:***

<b><i>Installation Schedule:</i></b>	
<b><i>Maintenance and Inspection:</i></b>	
<b><i>Responsible Staff:</i></b>	
<b><i>Design Specifications and Drawings:</i></b>	

### 7.3 Chemical Treatment

Check box if section not applicable to this site

***Soil Types***



List all the soil types (including soil types expected to be found in fill material) that are expected to be exposed during construction and that will be discharged to locations where chemicals will be applied:

***Treatment Chemicals***

List all treatment chemicals that will be used at the site and explain why these chemicals are suited to the soil characteristics:

Describe the dosage of all treatment chemicals you will use at the site or the methodology you will use to determine dosage:

Provide information from any applicable Safety Data Sheets (SDS):

Describe how each of the chemicals will stored:

Include references to applicable state or local requirements affecting the use of treatment chemicals, and copies of applicable manufacturer’s specifications regarding the use of your specific treatment chemicals and/or chemical treatment systems:

***Special Controls for Cationic Treatment Chemicals (if applicable)***

If you have been authorized by DWQ to use cationic treatment chemicals, identify the specific controls and implementation procedures you are required to implement to ensure that your use of cationic treatment chemicals will not lead to a violation of water quality standards or harm aquatic life:

***Schematic Drawings of Storm Water Controls/Chemical Treatment Systems***

Provide schematic drawings of any chemically enhanced storm water controls or chemical treatment systems to be used for application of treatment chemicals:

***Training***

Describe the training that personnel who handle and apply chemicals have received prior to permit coverage, or will receive prior to the use of treatment chemicals:

## SECTION 8: INSPECTIONS & CORRECTIVE ACTIONS

### 8.1 Inspections

**Minimum Inspection Schedule Requirements:**

<b>Standard Frequency:</b>
<input type="checkbox"/> Once every seven calendar days.
<input checked="" type="checkbox"/> Once every fourteen calendar days and within 24 hours of the end of a storm event of 0.5 inches or greater. Rain gauge/weather station used: <u>Eden, Utah   Current Weather Forecasts, Live Radar Maps &amp; News   WeatherBug</u>
<b>Increased Frequency (if applicable):</b>
<input type="checkbox"/> <i>Sites discharging to impaired or high-quality waters:</i> Once every seven calendar days and within 24 hours of the end of a storm event of 0.5 inches or greater.
<b>Decreased Frequency (if applicable):</b>
<input type="checkbox"/> <i>Arid areas:</i> once a month and within 24 hours of a 0.5-inch storm event or greater.
<input type="checkbox"/> <i>Semi-arid areas:</i> once a month and within 24 hours of a 0.5-inch storm event or greater during the dry season: <a href="#">List months for dry season</a> (also select the inspection schedule followed outside of the dry season).
<input type="checkbox"/> <i>Frozen conditions with work suspended – must have 3 months of continuous expected frozen conditions based on historical averages:</i> no inspections <a href="#">List months of suspended inspections</a> (also select the inspection schedule followed when not frozen)
<input type="checkbox"/> <i>Frozen conditions with continued activities - must have 3 months of continuous expected frozen conditions based on historical averages:</i> once per month <a href="#">List months of frozen conditions</a> (also select the inspection schedule followed when not frozen)
<b>Other:</b>
<input type="checkbox"/> Describe alternative frequency: <a href="#">List alternative schedule, must meet minimum requirements</a>

Inspection Reports are filed in Appendix C

## **8.2 Corrective Actions**

### Personnel Responsible for Corrective Actions

- The SWPPP Inspector from GENEVA ROCK PRODUCTS will submit a copy of the inspection report by email to the project manager, Casey Harris and/or anyone they require to receive a copy. For corrective actions identified, Mr. Jaysen Jorgensen will be responsible for initiating the corrective action within 24 hours of the report and completing maintenance as soon as possible or before the next storm event if the corrective action was not caused by rain or precipitation. For any corrective actions requiring a SWPPP amendment or change to a stormwater conveyance or control design, Mr. Jorgensen will initiate the corrective action and amend the SWPPP.

### Corrective Action Forms

- Corrective Action forms will be submitted by email to the project manager, Casey Harris and/or anyone they require to receive a copy.

Correction Action Report is filed in Appendix D.

## **8.3 Delegation of Authority**

### **Duly Authorized Representative(s) or Position(s):**

GENEVA ROCK PRODUCTS  
Casey Harris, Project Manager  
1235 West Stock Road  
Ogden, Utah 84401  
Cell: 435-994-0619  
Email: charris@genevarock.com

See the signed delegation of authority forms in Appendix E.

## SECTION 9: RECORDKEEPING

### 9.1 Recordkeeping

**Instructions (CGP 7.3.10. and 9.10.):**

- The following is a list of records you must have accessible on site (electronically or paper) for inspectors to review:
  - ✓ A copy of the construction general permit (Appendix I)
  - ✓ The signed and certified NOI form or permit application form (Appendix B)
- Copies of the SWPPP and all reports required by the permit must be retained for at least three years from the date that the site is finally stabilized.
- For more on this subject, see *SWPPP Guide*, Chapter 6.C.

**Individual(s) Responsible for Training:**

GENEVA ROCK PRODUCTS will conduct training of all personnel where needed to understand governing permit regulations. Records of training will be maintained at the GENEVA ROCK PRODUCTS corporate office.

GENEVA ROCK PRODUCTS will ensure persons overseeing the SWPPP on this project understand governing permit regulations.

**Describe Training Conducted:**

- General stormwater and BMP awareness training for staff and subcontractors:
- Detailed training for staff and subcontractors with specific stormwater responsibilities:

Training Attendee Name	Title of Training	Duration	Date of Training

Training documentation and log are filed in Appendix F.

## 9.2 Log of Changes to the SWPPP

**Instructions (CGP Part 7.5.3):**

- Create a log here of changes and updates to the SWPPP. You should include additions of new BMPs, replacement of failed BMPs, significant changes in the activities or their timing on the project, changes in personnel, changes in inspection and maintenance procedures, updates to site maps, and so on.
- Instead of using the table, SWPPPs can also be redlined to show changes as long as the redlines are initialed and dated.

Description of the Amendment	Date of Amendment	Amendment Prepared by [Name(s) and Title]

## SECTION 10: CERTIFICATION

**Instructions:**

- The SWPPP should be signed and certified by the owner and/or the general contractor. Attach a copy of the NOI and a copy of the General Storm Water Permit for Construction Activity. You can get a copy of the General Storm Water Permit for Construction Activity on the same web page that this template was obtained (<https://deq.utah.gov/water-quality/general-construction-storm-water-updes-permits>)

Owner

I certify under penalty of law that this document and all attachments were prepared under my direction or supervision in accordance with a system designed to assure that qualified personnel properly gathered and evaluated the information submitted. Based on my inquiry of the person or persons who manage the system, or those persons directly responsible for gathering the information, the information submitted is, to the best of my knowledge and belief, true, accurate, and complete. I am aware that there are significant penalties for submitting false information, including the possibility of fine and imprisonment for knowing violations.

Name:

Title:

Signature:

Date:

General Contractor

I certify under penalty of law that this document and all attachments were prepared under my direction or supervision in accordance with a system designed to assure that qualified personnel properly gathered and evaluated the information submitted. Based on my inquiry of the person or persons who manage the system, or those persons directly responsible for gathering the information, the information submitted is, to the best of my knowledge and belief, true, accurate, and complete. I am aware that there are significant penalties for submitting false information, including the possibility of fine and imprisonment for knowing violations.

Name:

Title:

Signature:

Date:

## SECTION 11: SWPPP PREPARER CERTIFICATION

SWPPP Preparer

I certify under penalty of law that this document and all attachments were prepared under my direction or supervision in accordance with a system designed to assure that qualified personnel properly gathered and evaluated the information submitted. Based on my inquiry of the person or persons who manage the system, or those persons directly responsible for gathering the information, the information submitted is, to the best of my knowledge and belief, true, accurate, and complete. I am aware that there are significant penalties for submitting false information, including the possibility of fine and imprisonment for knowing violations.

Name: Jennie Gallegos

Title: Erosion Control Analyst

---

Signature: 

Date: July 21, 2023

---

## **SWPPP APPENDICES**

Attach the following documentation to the SWPPP:

***Appendix A – Site Maps***

***Appendix B – NOI***

***Appendix C – Inspection Reports***

***Appendix D – Corrective Action Report***

***Appendix E – Subcontractor  
Certifications/Agreements/Delegation of  
Authority (see CGP 9.16(1) b.)***

***Appendix F – Training Logs and Certifications (see CGP 6)***

***Appendix G – Additional Information (i.e., Other permits such as  
dewatering, stream alteration, wetland; and out of  
date swppp documents)***

***Appendix H – BMP Instruction and Detail Specifications***

***Appendix I – Construction General Permit***



## **Appendix A: Site Maps**



Include any site maps in this appendix. For site map requirements review SWPPP section 2.5.



# Overlook Point

E. Overlook Drive, Eden

## Legend

-  Aspen Ridge at Powder Mountain
-  Overlook Dr
-  Overlook Point

 Aspen Ridge at Powder Mountain

 Overlook Dr

 Overlook Point





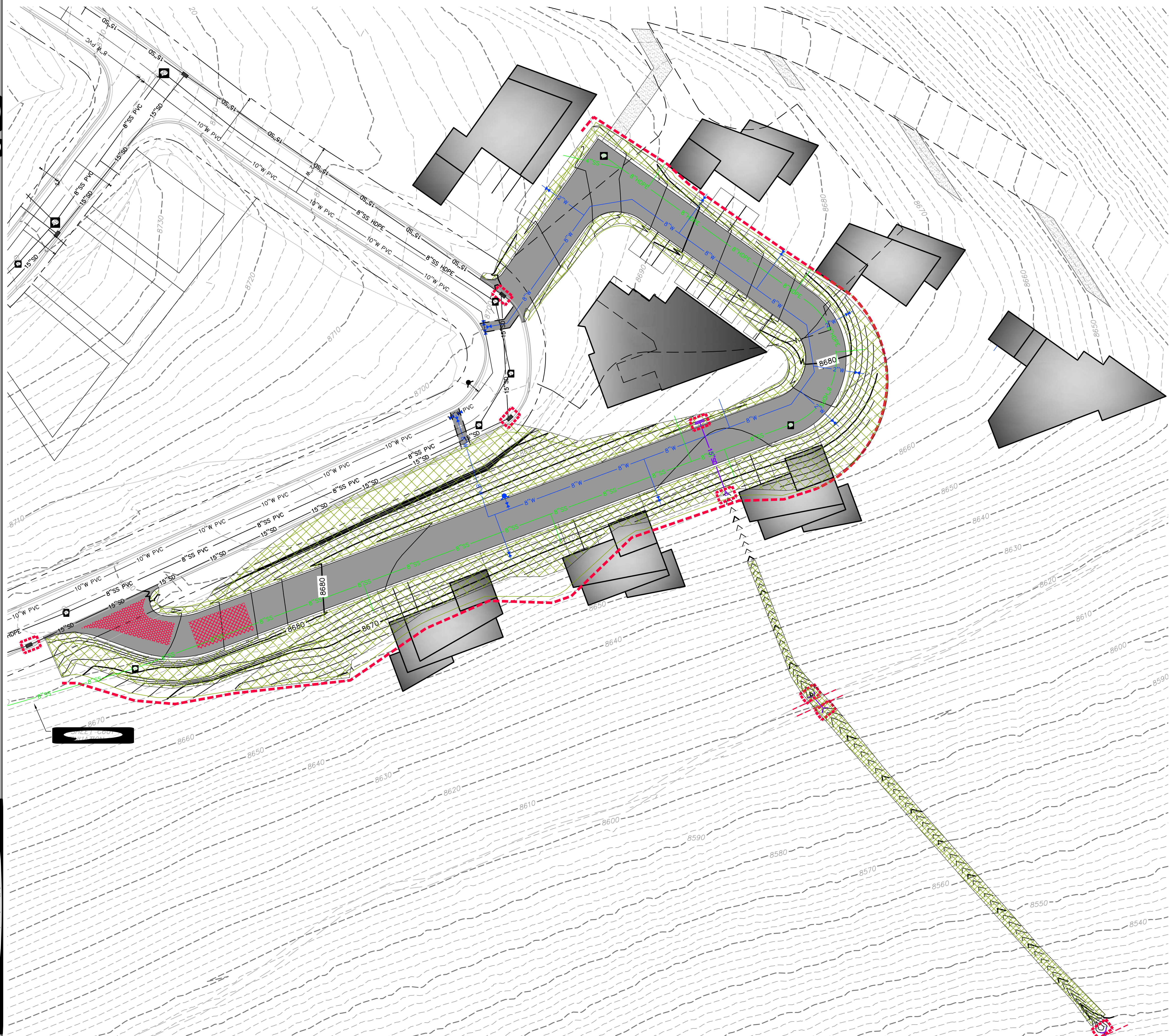

**LEGEND**

- 10" W PVC
- 8" SS PVC
- 8" HDPE
- 15" SD
- Gravel
- Grass
- Hydroseed
- Geotextile
- Check Dam
- Slope Protection
- Structure

**SEEDING DISTURBED AREAS WITH A TACKIFIER VIA HYDROSEEDING SEED MIXTURE:**

- MEADOW BROME (RIGOR) 14 lb/AC
- RICHLAND GRASS 10 lb/AC
- PERENNIAL Ryegrass (ADAK) 4 lb/AC
- W PERPENDICULAR TO SLOPE
- RIGHT SIDE OF ROAD

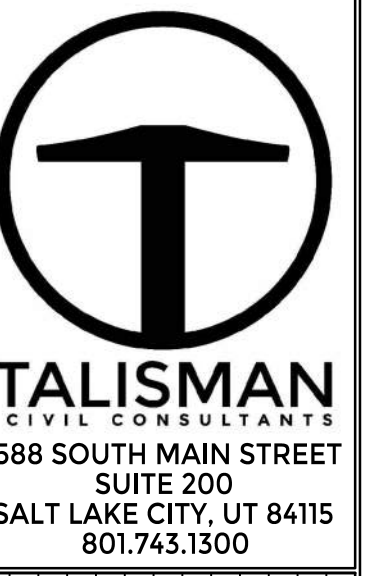

**POWDER POINT**  
**POWDER MOUNTAIN, UTAH**  
**EROSION CONTROL PLAN**

TCC JOB NUMBER: 22-126  
DATE: 06.29.2023

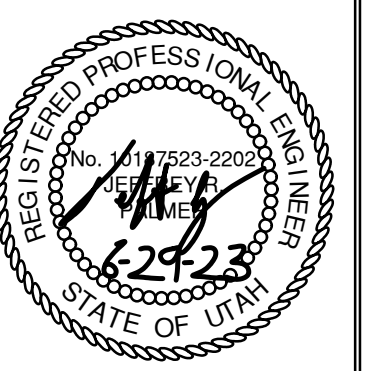

**C600**





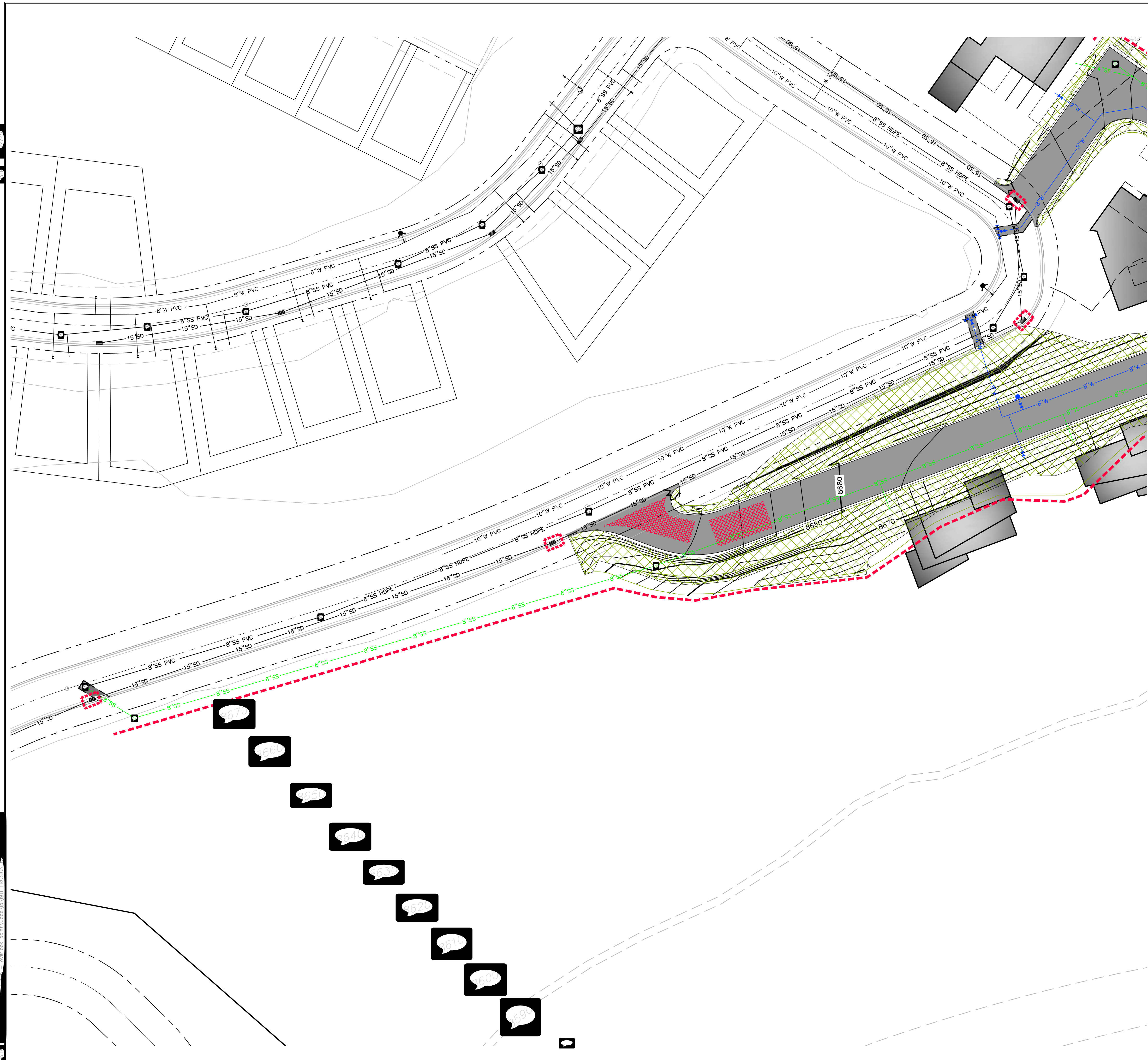

**POWDER POINT**  
**POWDER MOUNTAIN, UTAH**  
**OFFSITE EROSION CONTROL PLAN**  
 TCC JOB NUMBER: 22-126      DATE: 06.29.2023

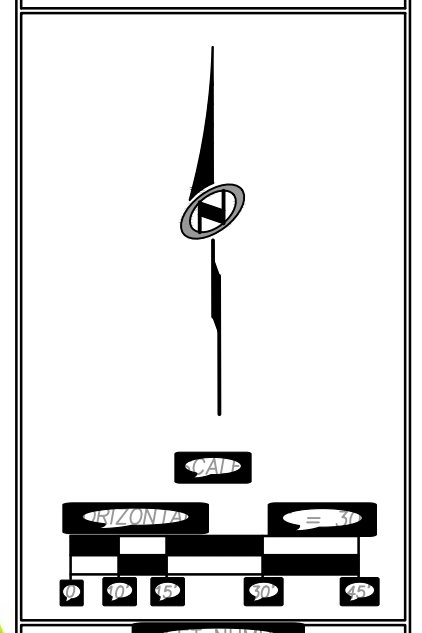
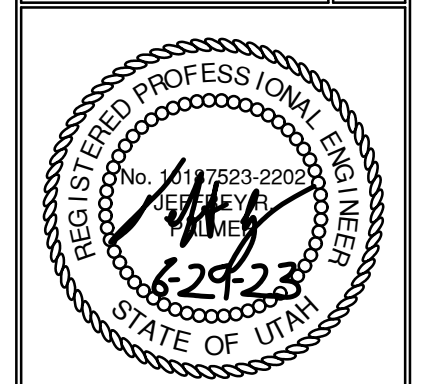

**C601**

## **Appendix B: NOI**

Include a copy of your NOI in this appendix. The NOI must be signed.





Notice of Intent (NOI) for Storm Water Discharges Associated with Construction  
Activity Under the Construction General Permit (CGP) UPDES General Permit  
No. UTRC00000

# NOI

## Permit Information

Master Permit Number: UTRC00000

UPDES ID: UTRC07218

State/Territory to which your project/site is discharging: UT

Is your project/site located on federally recognized Indian Country Lands? No

Which type of form would you like to submit? Notice of Intent (NOI)

Have stormwater discharges from your project/site been covered previously under an UPDES permit? No

Has a Stormwater Pollution Prevention Plan (SWPPP) been prepared in advance of filling this NOI, as required? Yes

## Owner/Operator Information

### Owner Information

Owner: Overlook Point LLC

Status of Owner: Private

Owner Mailing Address:

Address Line 1: 7843 East Horizon Run Cabin 126

Address Line 2:

City: Eden

ZIP/Postal Code: 84310

State: UT

### Owner Point of Contact Information

First Name Middle Initial Last Name: Scott   Bailey

Title: Owner

Phone: 562-260-7369

Ext.:

Email: scottbailey@me.com

### Operator Information

Is the Operator Information the same as the Owner Information? No

Operator: Geneva Rock Products

Operator Mailing Address:

Address Line 1: 1224 Stock Road

Address Line 2:

City: Ogden

ZIP/Postal Code: 84401

State: UT

### Operator Point of Contact Information

First Name Middle Initial Last Name: Casey   Harris

Title: Project Manager

Phone: 435-994-0619

Ext.:

Email: charris@genevarock.com

### NOI Preparer Information

This NOI is being prepared by someone other than the certifier.

## Project/Site Information

Project/Site Name: Overlook Point

Project Number:

Project/Site Address

Address Line 1: E Overlook Drive

Address Line 2:

City: Eden

ZIP/Postal Code: 84310

State: UT

County or Similar Division: Weber

Have you submitted a Fugitive Dust Control Plan to UT Division of Air Quality? No

## Latitude/Longitude for the Project/Site

Coordinate System: Decimal Degrees

Latitude/Longitude: 41.364669°N, 111.740861°W

Estimated Project Start Date: 07/19/2023

Estimated Project End Date: 12/31/2023

Total Area of Plot (in Acres): 4.25

Estimated Area to be Disturbed (in Acres): 1.3

## Proposed Best Management Practices

Check Dams

Structural Controls (Berms, Ditches, etc.)

## Proposed Good Housekeeping Practices

Sanitary/Portable Toilet

Washout Areas

Track Out Controls

## Site Construction Types

Residential

Road

Utility

### Site Activity Information

Municipal Separate Storm Sewer System (MS4) Operator Name: Weber County (Unincorporated Areas)

Receiving Water Body: Middle Fork Ogden River

→ This is known

What is the estimated distance to the nearest water body? 2500

Unit: Feet

Is the receiving water designated as impaired? No

Will any part of the project area be located within 50 feet of any Water of the State? No

Does this project site have any other UPDES permits? No

### Subdivision Information

Is this project involved in the development of a subdivision? No

### Certification Information

I certify under penalty of law that this document and all attachments were prepared under my direction or supervision in accordance with a system designed to assure that qualified personnel properly gathered and evaluated the information submitted. Based on my inquiry of the person or persons who manage the system, or those persons directly responsible for gathering the information, the information submitted is, to the best of my knowledge and belief, true, accurate, and complete. I have no personal knowledge that the information submitted is other than true, accurate, and complete. I am aware that there are significant penalties for submitting false information, including the possibility of fine and imprisonment for knowing violations. Signing an electronic document on behalf of another person is subject to criminal, civil, administrative, or other lawful action.

Certified By: Casey Harris

Certifier Title: Project Manager

Certifier Email: charris@genevarock.com

Certified On: 07/11/2023 11:11 AM ET

## **Appendix C: Inspection Reports**

Place all completed inspection reports in this appendix. You may also put blank inspection reports here to be completed.





# SWPPP COMPLIANCE INSPECTION FORM



## BACKGROUND INFORMATION

Project Name:		Project PIN:		MS4 Name:	
Project Location:				County:	
Owner:		General Contractor:		UPDES Permit #:	
Project Contact:		Phone:		Permit Expiration:	

## INSPECTION INFORMATION

Date of Inspection:		Start time:		Start time:		Date of Last Rain Event:	
Reason for Inspection:	<input type="checkbox"/> Scheduled <input type="checkbox"/> > 0.5" Rain <input type="checkbox"/> Random				Duration (hrs):		
Weather:	<input type="checkbox"/> Sunny <input type="checkbox"/> Cloudy <input type="checkbox"/> Rainy <input type="checkbox"/> Snowy				Approx. Rainfall (in):		

1. Is the SWPPP on site and accessible, or is the SWPPP location posted in an obvious place and reasonably accessible (in a short time)?	<input type="checkbox"/> Yes <input type="checkbox"/> No <input type="checkbox"/> NA
2. Are erosion control, sediment control, and good housekeeping BMP's installed on the site as shown in the SWPPP?	<input type="checkbox"/> Yes <input type="checkbox"/> No <input type="checkbox"/> NA
3. Has the SWPPP been updated to reflect the current site conditions (modifications dated & initialed on site map, new BMPs on site map, discontinued BMPs crossed off site map, new BMP details & spec's in SWPPP, SWPPP amendment Log, etc.)?	<input type="checkbox"/> Yes <input type="checkbox"/> No <input type="checkbox"/> NA
4. Are on-site inspections being performed and recorded by a qualified person on a weekly or biweekly basis, reporting items required by permit? (Inspector name & qualifications, weather, problems/repairs, corrective action, new BMPs, removed BMPs, discharges, etc.)	<input type="checkbox"/> Yes <input type="checkbox"/> No <input type="checkbox"/> NA
5. Have all corrective action items from previous inspections been addressed and documented within the time frame allotted by the inspector?	<input type="checkbox"/> Yes <input type="checkbox"/> No <input type="checkbox"/> NA
6. Are SW flows entering and leaving the construction site controlled, managed, or diverted around the site? (e.g. perimeter controls, berms, silt fence, upgradient boundary diversion, down gradient boundary sediment control, etc.)	<input type="checkbox"/> Yes <input type="checkbox"/> No <input type="checkbox"/> NA
7. Is there evidence of sediment discharge such as mud flows or soil deposits from the construction site in downstream locations?	<input type="checkbox"/> Yes <input type="checkbox"/> No <input type="checkbox"/> NA
8. Is there evidence of vehicles tracking soil off the construction site?	<input type="checkbox"/> Yes <input type="checkbox"/> No <input type="checkbox"/> NA
9. Is there soil, construction material, landscaping items, or other debris piled on impervious surfaces (roads, drives) that could be washed with SW to a storm drain or water body?	<input type="checkbox"/> Yes <input type="checkbox"/> No <input type="checkbox"/> NA
10. Is there a need to repair, maintain, or improve erosion control BMPs (temporary stabilization, erosion blankets, mulch, vegetated strips, rip rap, surface roughening, pipe slope drain, dust control, etc)?	<input type="checkbox"/> Yes <input type="checkbox"/> No <input type="checkbox"/> NA
11. Is there a need to repair, maintain, or improve sediment control BMPs (silt fence, check dams, fiber rolls, sediment trap/basin, inlet protection, waddles, straw bails, curb cut-back, etc)?	<input type="checkbox"/> Yes <input type="checkbox"/> No <input type="checkbox"/> NA
12. Is there a need to repair, maintain, or improve good housekeeping controls (clean track out pad, sweeping, construction materials management, litter/trash control, port-o-potties staked down, fueling areas, concrete wash out area, proper curb ramps, spill prevention, etc)?	<input type="checkbox"/> Yes <input type="checkbox"/> No <input type="checkbox"/> NA
13. Are there disturbed areas that have not had construction activities for 14 to 21 days without stabilization? (except snow or frozen ground)?	<input type="checkbox"/> Yes <input type="checkbox"/> No <input type="checkbox"/> NA
14. Are there places where BMPs are needed and should be installed or not needed and should be removed?	<input type="checkbox"/> Yes <input type="checkbox"/> No <input type="checkbox"/> NA

*I certify under penalty of law that this document and all attachments were prepared under my direction or supervision in accordance with a system designed to assure that qualified personnel properly gathered and evaluated the information submitted. Based on my inquiry of the person or persons who manage the system, or those persons directly responsible for gathering the information, the information submitted is, to the best of my knowledge and belief true, accurate, and complete. I am aware that there are significant penalties for submitting false information, including the possibility of fine and imprisonment for knowing violations.*

Owner:				
	(Print Name)	(Title)	(Signature)	(Date)
General Contractor:				
	(Print Name)	(Title)	(Signature)	(Date)



# COMMENTS AND CORRECTIVE ACTIONS FOR SWPPP COMPLIANCE



Project Name:		Date of Inspection:		Page		of	
Project Location:							

### COMMENTS

### CORRECTIVE ACTIONS

Identify the problem and its location. If appropriate, describe (in general terms) what needs to be completed.

#	SEV Code	Location and Description of Deficiency, Spill, or Permit Violation	Corrective Action Needed
1			
2			
3			
4			
5			
6			

### SEV Codes and Descriptions

DOR11	Discharge without a permit	BR19B	Failure to properly operate and maintain BMP's
DOR18	Failure to apply for a Notice of Termination	BR19A	Failure to properly install/implement BMP's
BOR12	Failure to conduct inspections	EOR16	Failure to submit required report (non-DMR)
BOC17	Failure to develop any or adequate SWPPP/SWMP	AOR22	Narrative effluent violation
BOC18	Failure to implement SWPPP/SWMP	DOR12	Failure to submit required permit information
BOR41	Failure to maintain records	AOR12	Numeric effluent violation
COR11	Failure to monitor	BOR42	Violation of a milestone in an order

## **Appendix D: Corrective Action Report**

## Appendix D – Corrective Action Report

<b>Inspection Date</b>	<b>Inspector Name(s)</b>	<b>Description of BMP Deficiency</b>	<b>Corrective Action Needed (including planned date/responsible person)</b>	<b>Date Action Taken/Responsible person</b>

## **Appendix E: Subcontractor Certifications/Agreements/Delegation of Authority (CGP 9.16.(1) b.)**

SUBCONTRACTOR CERTIFICATION  
STORM WATER POLLUTION PREVENTION PLAN

Project Number: \_\_\_\_\_

Project Title: **Overlook Point** \_\_\_\_\_

Operator(s): \_\_\_\_\_

As a subcontractor, you are required to comply with the Storm water Pollution Prevention Plan (SWPPP) for any work that you perform on-site. Any person or group who violates any condition of the SWPPP may be subject to substantial penalties or loss of contract. You are encouraged to advise each of your employees working on this project of the requirements of the SWPPP. A copy of the SWPPP is available for your review at request.

Each subcontractor engaged in activities at the construction site that could impact storm water must be identified and sign the following certification statement:

**I certify under the penalty of law that I have read and understand the terms and conditions of the SWPPP for the above designated project and agree to follow the BMPs and practices described in the SWPPP.**

This certification is hereby signed in reference to the above-named project:

Company: \_\_\_\_\_

Address: \_\_\_\_\_

Telephone Number: \_\_\_\_\_

Type of construction service to be provided: \_\_\_\_\_

\_\_\_\_\_  
\_\_\_\_\_

Signature: \_\_\_\_\_

Title: \_\_\_\_\_

Date: \_\_\_\_\_

### Delegation of Authority

I, \_\_\_\_\_, hereby designate the person or specifically described position below to be a duly authorized representative for the purpose of overseeing compliance with environmental requirements, including the UPDES “General Permit for Storm Water Discharges Associated with Construction Activity” (CGP), at the construction site:

**Overlook Point, Permit No. UTRC07218**

The designee is authorized to sign all reports required by the Permit and other information requested by the Director of the Utah Division of Water Quality, or by an authorized representative of the Executive Secretary.

Name of Person or Position: \_\_\_\_\_

Owner/Operator: \_\_\_\_\_

Mailing Address: \_\_\_\_\_

City, State, Zip Code: \_\_\_\_\_

Phone Number: \_\_\_\_\_

By signing this authorization, I confirm that I meet the requirements to make such a designation as set forth in Part 9.16 of the CGP, and that the designee above meets the definition of a “duly authorized representative” as set forth in Part 9.16.b. of the CGP.

I certify under penalty of law that this document and all attachments were prepared under my direction or supervision in accordance with a system designed to assure that qualified personnel properly gather and evaluate the information submitted. Based on my inquiry of the person or persons who manage the system, or those persons directly responsible for gathering the information, the information submitted is, to the best of my knowledge and belief, true, accurate, and complete. I am aware that there are significant penalties for submitting false information, including the possibility of fine and imprisonment for knowing violations.

Name: \_\_\_\_\_

Title: \_\_\_\_\_

Signature: \_\_\_\_\_

Date: \_\_\_\_\_

## **Appendix F: Training Logs and Certifications (see CGP 6)**

Certifications for SWPPP inspectors or writers can also be placed in this appendix.



# Certificate of Training

Aiden Gallegos

Environmental Control Supervisor

Certification Date: 09-MAY-2022

Expires 3 years from certification date.



*Certificate of Achievement*

*presented to*

Alfredo Gallegos

for the successful completion of  
Environmental Control Supervisor (ECS) Training

19-NOV-2020

Keep up the great work!





# Attendance Recognition

## C E R T I F I C A T E

 Gallegos

has earned a 0.5 continuing education  
unit for attending the full-day training course

CPESC: Certified Professional in  
Erosion and Sediment Control

**StormCon**<sup>®</sup>  
The North American Surface Water Quality Conference & Exposition

August 19, 2012  
Sheraton, Denver, CO

Dan Waldman  
President  
Forester Media, Inc.



OSHA OUTREACH TRAINING

# Completion Certificate

**JOSE A GALLEGOS**

has successfully completed the following course:

**10-Hr OSHA Training for the Construction Industry**

5/3/2021



**David Couch**

OSHA Authorized Trainer

Construction #: 20-0106090 General #: 20-0079854

*As an OSHA Outreach trainer, I verify that I have conducted this OSHA Outreach training class in accordance with OSHA Outreach Training Program requirements. I will document this class to my OSHA Authorizing Training Organization. Upon successful review of my documentation, I will provide each student their completion card within 90 days of the end of the class.*

OSHA Authorized Provider:



UNIVERSITY OF  
SOUTH FLORIDA

**Environmental  
Control  
Supervisor  
Training**



**Alfredo Gallegos**

Hours of Instruction: 3  
Location: Online

**Certification Date: 04/12/2018**

*Expires 3 years from certification date*

*Rod Hess*

---

Rod Hess, Environmental

**CERTIFICATE  
OF TRAINING**



Utah Department of Transportation  
*Certificate of Training*

**Alfredo Gallegos**

*has satisfactorily completed the*

*Environmental Control Supervisor Training*

*Location:* Salt Lake City, Utah

*Hours of Instruction:* 8

*Date:* April 6, 2006

**Terry Johnson**

*Instructor*

**Jerry Chaney**

*Coordinator*





# International Erosion Control Association

3001 S Lincoln Ave., Suite A, Steamboat Springs, Colorado 80487 ~ 970-879-3010 ~ www.ieca.org  
EC08 — Orlando, Florida

## C E R T I F I C A T E   O F   C O M P L E T I O N

*May it be known by all who read this that:*

**Alfredo Gallegos**

*has successfully completed*

***Certified Inspector of Sediment and Erosion Control (CISEC) Training Modules***

*and has earned .6 Continuing Education Units or 6.0 Professional Development Hours*

*Presented this 21st day of February, 2008*

*Executive Director*

*President*

May be applied to the following "IECA Trained" Tracks: Inspector in Training





# International Erosion Control Association

3001 S Lincoln Ave., Suite A, Steamboat Springs, Colorado 80487 ~ 970-879-3010 ~ www.ieca.org  
EC07 — Reno, Nevada

## CERTIFICATE OF COMPLETION

*May it be known by all who read this that:*

**Alfredo Gallegos**

*has successfully completed*

***Effective Inspection Programs for Construction Site Runoff Control***

*and has earned 0.6 Continuing Education Units or 6.0 Professional Development Hours*

*Presented this 13th day of February, 2007*

*Ben Nottel*

*Executive Director*

*Doug Wimbler*

*President*

May be applied to the following "IECA Trained" Track: Inspector in Training





Utah Department of Transportation  
*Certificate of Training*

**Jennie Gallegos**

*has satisfactorily completed the*

*Environmental Control Supervisor Training*

*Location:* Salt Lake City, Utah

*Hours of Instruction:* 8

*Date:* August 11, 2005

*Terry Johnson*

*Instructor*

*Jerry Chaney*

*Coordinator*





# International Erosion Control Association

3001 S Lincoln Ave., Suite A, Steamboat Springs, Colorado 80487 ~ 970-879-3010 ~ www.ieca.org  
EC07 — Reno, Nevada

## CERTIFICATE OF COMPLETION

*May it be known by all who read this that:*

**Jennie Gallegos**

*has successfully completed*

***How to Write & Implement a SWPPP  
to Meet NPDES Requirements***

*and has earned 0.6 Continuing Education Units or 6.0 Professional Development Hours*

*Presented this 13th day of February, 2007*

*Ben Nottel*

*Executive Director*

*Doug Wimer*

*President*

May be applied to the following "IECA Trained" Track: Construction Site Storm Water Management



A decorative border with a repeating wavy pattern in blue, framing the entire certificate content.

# Attendance Recognition

## C E R T I F I C A T E

Jennie Gallegos

---

has earned a 0.5 continuing education  
unit for attending the full-day training course

CPESC: Certified Professional in  
Erosion and Sediment Control

**StormCon**<sup>®</sup>  
The North American Surface Water Quality Conference & Exposition

August 19, 2012  
Sheraton, Denver, CO

Dan Waldman  
President  
Forester Media, Inc.

**Environmental  
Control  
Supervisor  
Training**



*Jennie Gallegos*

Hours of Instruction: 3  
Location: Online

**Certification Date: 04/12/2018**

*Expires 3 years from certification date*

*Rod Hess*

---

Rod Hess, Environmental

**CERTIFICATE  
OF TRAINING**

## Appendix F – SWPPP Training Log

### Storm Water Pollution Prevention Training Log

Project Name:

**Overlook Point**

Project Location:

**East Overlook Drive, Eden, UT**

Instructor's Name(s):

Instructor's Title(s):

Course Location: \_\_\_\_\_ Date: \_\_\_\_\_

Course Length (hours): \_\_\_\_\_

Storm Water Training Topic: *(check as appropriate)*

- Erosion Control BMPs       Emergency Procedures  
 Sediment Control BMPs       Good Housekeeping BMPs  
 Non-Storm Water BMPs

Specific Training Objective: \_\_\_\_\_

\_\_\_\_\_

Attendee Roster: *(attach additional pages as necessary)*

No.	Name of Attendee	Company
1		
2		
3		
4		
5		
6		
7		
8		
9		
10		

## **Appendix G: Additional Information**

Use this appendix for additional information such as other permits (dewatering, stream alteration, etc.) or out of date SWPPP documents.

## **Appendix H: BMP Instruction and Detail Specifications**

# POWDER POINT AT POWDER MOUNTAIN DESIGN DEVELOPMENT DRAWINGS

Located in Weber County, Utah

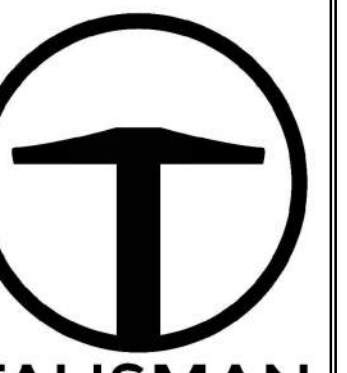

**TALISMAN**  
CIVIL CONSULTANTS  
1588 SOUTH MAIN STREET  
SUITE 200  
SALT LAKE CITY, UT 84115  
801.743.1500

**SHEET INDEX:**

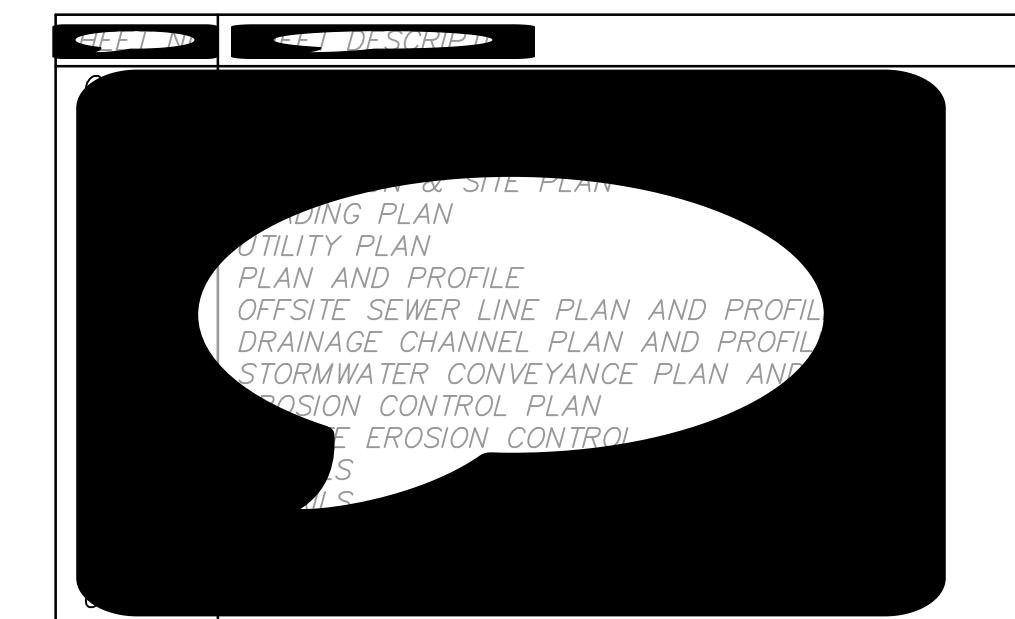

**POWDER POINT  
POWDER MOUNTAIN, UTAH  
COVER SHEET**

DATE: 06.29.2023

TCC JOB NUMBER: 22-126

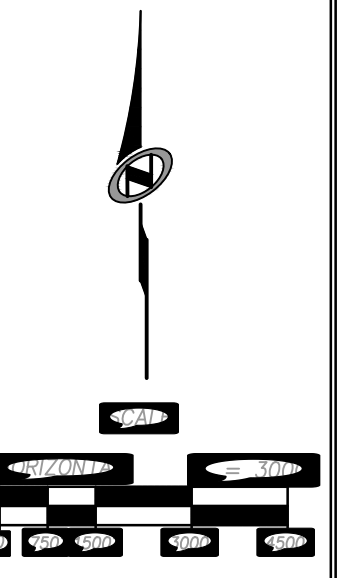
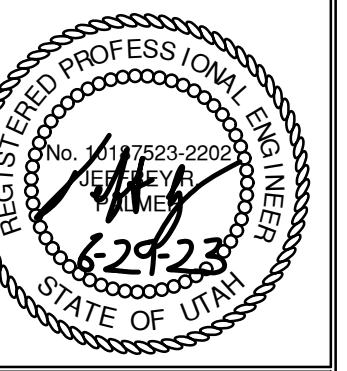

**C000**



GENERAL NOTES

- ALL CONSTRUCTION MUST STRICTLY FOLLOW THE STANDARDS AND SPECIFICATIONS SET FORTH BY: GOVERNING UTILITY MUNICIPALITY, GOVERNING CITY OR COUNTY (IF UNINCORPORATED), INDIVIDUAL PRODUCT MANUFACTURERS, THE DESIGN ENGINEER, AND AMERICAN PUBLIC WORKS ASSOCIATION (APWA). THE ORDER LISTED ABOVE IS ARRANGED BY SENIORITY. IF A CONSTRUCTION PRACTICE IS NOT SPECIFIED BY ANY OF THE LISTED SOURCES, CONTRACTOR MUST CONTACT DESIGN ENGINEER FOR DIRECTION.
- CONTRACTOR TO STRICTLY FOLLOW GEOTECHNICAL RECOMMENDATIONS FOR THIS PROJECT. ALL GRADING INCLUDING BUT NOT LIMITED TO CUT, FILL, COMPACTION, ASPHALT SECTION, SUBBASE, TRENCH EXCAVATION/BACKFILL, SITE GRUBBING, RETAINING WALLS AND FOOTINGS MUST BE COORDINATED DIRECTLY WITH THE PROJECT GEOTECHNICAL ENGINEER.
- TRAFFIC CONTROL, STRIPING & SIGNAGE TO CONFORM TO CURRENT UDOT TRANSPORTATION ENGINEER'S MANUAL AND MANUAL OF UNIFORM TRAFFIC CONTROL DEVICES.
- ANY AREA OUTSIDE THE LIMIT OF WORK THAT IS DISTURBED SHALL BE RESTORED TO ITS ORIGINAL CONDITION AT NO COST TO OWNER.
- CONSULT ALL OF THE DRAWINGS AND SPECIFICATIONS FOR COORDINATION REQUIREMENTS BEFORE COMMENCING CONSTRUCTION.
- AT ALL LOCATIONS WHERE EXISTING PAVEMENT ABUTS NEW CONSTRUCTION, THE EDGE OF THE EXISTING PAVEMENT SHALL BE SAWCUT TO A CLEAN, SMOOTH EDGE.
- ALL CONSTRUCTION AND MATERIALS SHALL BE IN ACCORDANCE WITH THE MOST RECENT, ADOPTED EDITION OF ADA ACCESSIBILITY GUIDELINES.
- PRIOR TO STARTING CONSTRUCTION, THE CONTRACTOR SHALL BE RESPONSIBLE FOR MAKING SURE THAT ALL REQUIRED PERMITS AND APPROVALS HAVE BEEN OBTAINED. NO CONSTRUCTION OR FABRICATION SHALL BEGIN UNTIL THE CONTRACTOR HAS RECEIVED THOROUGHLY REVIEWED PLANS AND OTHER DOCUMENTS APPROVED BY ALL OF THE PERMITTING AGENCIES.
- CONTRACTOR IS RESPONSIBLE FOR SCHEDULING AND NOTIFYING ENGINEER OR INSPECTING AUTHORITY 48 HOURS IN ADVANCE OF COVERING UP ANY PHASE OF CONSTRUCTION REQUIRING OBSERVATION.
- ANY WORK IN THE PUBLIC RIGHT-OF-WAY WILL REQUIRE PERMITS FROM THE APPROPRIATE, CITY, COUNTY OR STATE AGENCY CONTROLLING THE ROAD, INCLUDING OBTAINING REQUIRED INSPECTIONS.
- ALL DIMENSIONS, GRADES & UTILITY DESIGNS SHOWN ON THE PLANS SHALL BE VERIFIED BY THE CONTRACTOR PRIOR TO CONSTRUCTION. CONTRACTOR SHALL NOTIFY ENGINEER OF ANY DISCREPANCIES PRIOR TO PROCEEDING WITH CONSTRUCTION FOR NECESSARY PLAN OR GRADE CHANGES.
- CONTRACTOR MUST VERIFY ALL EXISTING CONDITIONS BEFORE BIDDING AND BRING UP ANY QUESTIONS BEFOREHAND.
- SITE GRADING SHALL BE PERFORMED IN ACCORDANCE WITH THESE PLANS AND SPECIFICATIONS AND THE RECOMMENDATIONS SET FORTH BY THE GEOTECHNICAL ENGINEER.
- CATCH SLOPES SHALL BE GRADED AS SPECIFIED ON GRADING PLANS.
- CONTRACTOR SHALL BE RESPONSIBLE FOR ALL FLAGGING, CAUTION SIGNS, LIGHTS, BARRICADES, FLAGPERSONS, AND ALL OTHER DEVICES NECESSARY FOR PUBLIC SAFETY.
- CONTRACTOR SHALL, AT THE TIME OF BIDDING AND THROUGHOUT THE PERIOD OF THE CONTRACT, BE LICENSED IN THE STATE OF UTAH AND SHALL BE BONDABLE FOR AN AMOUNT EQUAL TO OR GREATER THAN THE AMOUNT BID AND TO DO THE TYPE OF WORK CONTEMPLATED IN THE PLANS AND SPECIFICATIONS. CONTRACTOR SHALL BE SKILLED AND REGULARLY ENGAGED IN THE GENERAL CLASS AND TYPE OF WORK CALLED FOR IN THE PLANS AND SPECIFICATIONS.
- CONTRACTOR SHALL INSPECT THE SITE OF THE WORK PRIOR TO BIDDING TO SATISFY THEM BY PERSONAL EXAMINATION OR BY SUCH OTHER MEANS AS THEY MAY PREFER OF THE LOCATION OF THE PROPOSED WORK AND OF THE ACTUAL CONDITIONS OF AND AT THE SITE OF WORK. IF, DURING THE COURSE OF THEIR EXAMINATION, A BIDDER FINDS FACTS OR CONDITIONS WHICH APPEAR TO THEM TO BE IN CONFLICT WITH THE LETTER OR SPIRIT OF THE PROJECT PLANS AND SPECIFICATIONS, THEY SHALL CONTACT THE ENGINEER FOR ADDITIONAL INFORMATION AND EXPLANATION BEFORE SUBMITTING THEIR BID. SUBMISSION OF A BID BY THE CONTRACTOR SHALL CONSTITUTE ACKNOWLEDGMENT THAT, IF AWARDED THE CONTRACT, THEY HAVE RELIED AND ARE RELYING ON THEIR OWN EXAMINATION OF (1) THE SITE OF THE WORK, (2) ACCESS TO THE SITE, AND (3) ALL OTHER DATA AND MATTERS REQUISITE TO THE FULFILLMENT OF THE WORK AND ON THEIR OWN KNOWLEDGE OF EXISTING FACILITIES ON AND IN THE VICINITY OF THE SITE OF THE WORK TO BE CONSTRUCTED UNDER THIS CONTRACT. THE INFORMATION PROVIDED BY THE ENGINEER IS NOT INTENDED TO BE A SUBSTITUTE FOR, OR A SUPPLEMENT TO, THE INDEPENDENT VERIFICATION BY THE CONTRACTOR TO THE EXTENT SUCH INDEPENDENT INVESTIGATION OF SITE CONDITIONS IS DEEMED NECESSARY OR DESIRABLE BY THE CONTRACTOR. CONTRACTOR SHALL ACKNOWLEDGE THAT THEY HAVE NOT RELIED SOLELY UPON OWNER OR ENGINEER FURNISHED INFORMATION REGARDING SITE CONDITIONS IN PREPARING AND SUBMITTING THEIR BID.
- CONTRACTOR SHALL BE RESPONSIBLE TO PROVIDE ALL WATER, POWER, SANITARY FACILITIES AND TELEPHONE SERVICES AS REQUIRED FOR THE CONTRACTOR'S USE DURING CONSTRUCTION.
- CONTRACTOR SHALL BE HELD RESPONSIBLE FOR ANY FIELD CHANGES MADE WITHOUT PRIOR WRITTEN AUTHORIZATION FROM THE OWNER, ENGINEER, AND/OR GOVERNING AGENCIES.
- CONTRACTOR SHALL EXERCISE DUE CAUTION AND SHALL CAREFULLY PRESERVE BENCH MARKS, CONTROL POINTS, REFERENCE POINTS AND ALL SURVEY STAKES, AND SHALL BEAR ALL EXPENSES FOR REPLACEMENT AND/OR ERRORS CAUSED BY THEIR UNNECESSARY LOSS OR DISTURBANCE.
- CONTRACTOR SHALL ASSUME SOLE AND COMPLETE RESPONSIBILITY FOR JOBSITE CONDITIONS DURING THE COURSE OF CONSTRUCTION OF THIS PROJECT, INCLUDING SAFETY OF ALL PERSONS AND PROPERTY. THIS REQUIREMENT SHALL APPLY CONTINUOUSLY AND NOT BE LIMITED TO NORMAL WORKING HOURS. THE CONTRACTOR SHALL DEFEND, INDEMNIFY AND HOLD THE OWNER AND ENGINEER HARMLESS FROM ANY AND ALL LIABILITY, REAL OR ALLEGED, IN CONNECTION WITH THE PERFORMANCE OF WORK ON THIS PROJECT, EXCEPTING FOR LIABILITY ARISING FROM THE SOLE NEGLIGENCE OF THE OWNER OR THE ENGINEER.
- CONTRACTOR SHALL BE RESPONSIBLE FOR ADEQUATELY SCHEDULING INSPECTION AND TESTING OF ALL FACILITIES CONSTRUCTED UNDER THIS CONTRACT. ALL TESTING SHALL CONFORM TO THE REGULATORY AGENCY'S STANDARD SPECIFICATIONS. ALL TESTING AND INSPECTION SHALL BE PAID FOR BY THE OWNER. ALL RE-TESTING AND/OR RE-INSPECTION SHALL BE PAID FOR BY THE CONTRACTOR.
- IF EXISTING IMPROVEMENTS NEED TO BE DISTURBED AND/OR REMOVED FOR THE PROPER PLACEMENT OF IMPROVEMENTS TO BE CONSTRUCTED BY THESE PLANS, THE CONTRACTOR SHALL BE RESPONSIBLE FOR PROTECTING EXISTING IMPROVEMENTS FROM DAMAGE. COST OF REPLACING OR REPAIRING EXISTING IMPROVEMENTS SHALL BE INCLUDED IN THE UNIT PRICE BID FOR ITEMS REQUIRING REMOVAL AND/OR REPLACEMENT. THERE WILL BE NO EXTRA COST DUE TO THE CONTRACTOR FOR REPLACING OR REPAIRING EXISTING IMPROVEMENTS.
- WHENEVER EXISTING FACILITIES ARE REMOVED, DAMAGED, BROKEN, OR CUT IN THE INSTALLATION OF THE WORK COVERED BY THESE PLANS OR SPECIFICATIONS, SAID FACILITIES SHALL BE REPLACED AT THE CONTRACTOR'S EXPENSE WITH MATERIALS EQUAL TO OR BETTER THAN THE MATERIALS USED IN THE ORIGINAL EXISTING FACILITIES. THE FINISHED PRODUCT SHALL BE SUBJECT TO THE APPROVAL OF THE OWNER, THE ENGINEER, AND THE RESPECTIVE REGULATORY AGENCY.
- CONTRACTOR SHALL MAINTAIN A NEATLY MARKED SET OF FULL-SIZE AS-BUILT RECORD DRAWINGS SHOWING THE FINAL LOCATION AND LAYOUT OF ALL STRUCTURES AND OTHER FACILITIES. AS-BUILT RECORD DRAWINGS SHALL REFLECT CHANGE ORDERS, ACCOMMODATIONS, AND ADJUSTMENTS TO ALL IMPROVEMENTS CONSTRUCTED, WHERE NECESSARY, SUPPLEMENTAL DRAWINGS SHALL BE PREPARED AND SUBMITTED BY THE CONTRACTOR. PRIOR TO ACCEPTANCE OF THE PROJECT, THE CONTRACTOR SHALL DELIVER TO THE ENGINEER ONE SET OF NEATLY MARKED AS-BUILT RECORD DRAWINGS SHOWING THE INFORMATION REQUIRED ABOVE. AS-BUILT RECORD DRAWINGS SHALL BE REVIEWED AND THE COMPLETE AS-BUILT RECORD DRAWING SET SHALL BE CURRENT WITH ALL CHANGES AND DEVIATIONS REDEFINED AS A PRECONDITION TO THE FINAL PROGRESS PAYMENT APPROVAL AND/OR FINAL ACCEPTANCE.
- WHERE THE PLANS OR SPECIFICATIONS DESCRIBE PORTIONS OF THE WORK IN GENERAL TERMS BUT NOT IN COMPLETE DETAIL, IT IS UNDERSTOOD THAT ONLY THE BEST GENERAL PRACTICE IS TO PREVAIL AND THAT ONLY MATERIALS AND WORKMANSHIP OF THE FIRST QUALITY ARE TO BE USED.

GENERAL NOTES CONT.



UTILITY NOTES

- CONTRACTOR SHALL COORDINATE LOCATION OF NEW "DRY UTILITIES" WITH THE APPROPRIATE UTILITY COMPANY, INCLUDING BUT NOT LIMITED TO: TELEPHONE SERVICE, GAS SERVICE, CABLE, POWER, INTERNET.
- EXISTING UTILITIES HAVE BEEN SHOWN ON THE PLANS USING A COMBINATION OF ON-SITE SURVEYS (BY OTHERS). PRIOR TO COMMENCING ANY WORK, IT SHALL BE THE CONTRACTOR'S RESPONSIBILITY TO HAVE EACH UTILITY COMPANY LOCATE, IN THE FIELD, THEIR MAIN AND SERVICE LINES. THE CONTRACTOR SHALL NOTIFY BLUE STAKES AT 1-800-662-4111 48 HOURS IN ADVANCE OF PERFORMING ANY EXCAVATION WORK. THE CONTRACTOR SHALL RECORD THE BLUE STAKES ORDER NUMBER AND FURNISH ORDER NUMBER TO OWNER AND ENGINEER PRIOR TO ANY EXCAVATION. IT WILL BE THE CONTRACTOR'S SOLE RESPONSIBILITY TO DIRECTLY CONTACT ANY OTHER UTILITY COMPANIES THAT ARE NOT MEMBERS OF BLUE STAKES. IT SHALL BE THE CONTRACTOR'S SOLE RESPONSIBILITY TO PROTECT ALL EXISTING UTILITIES SO THAT NO DAMAGE RESULTS TO THEM DURING THE PERFORMANCE OF THIS CONTRACT. ANY REPAIRS NECESSARY TO DAMAGED UTILITIES SHALL BE PAID FOR BY THE CONTRACTOR. THE CONTRACTOR SHALL BE REQUIRED TO COOPERATE WITH OTHER CONTRACTORS AND UTILITY COMPANIES INSTALLING NEW STRUCTURES, UTILITIES AND SERVICE TO THE PROJECT.
- CONTRACTOR SHALL POT HOLE ALL UTILITIES TO DETERMINE IF CONFLICTS EXIST PRIOR TO BEGINNING ANY EXCAVATION. NOTIFY ENGINEER OF ANY CONFLICTS. CONTRACTOR SHALL VERIFY LOCATION AND INVERTS OF EXISTING UTILITIES TO WHICH NEW UTILITIES WILL BE CONNECTED. PRIOR TO COMMENCING ANY EXCAVATION WORK THE CONTRACTOR SHALL NOTIFY ALL UTILITY COMPANIES IN ACCORDANCE WITH THE REQUIRED PROCEDURES.
- CARE SHOULD BE TAKEN IN ALL EXCAVATIONS DUE TO POSSIBLE EXISTENCE OF UNRECORDED UTILITY LINES. EXCAVATION REQUIRED WITHIN PROXIMITY OF EXISTING UTILITY LINES SHALL BE DONE BY HAND. CONTRACTOR SHALL REPAIR ANY DAMAGE TO EXISTING UTILITY LINES OR STRUCTURES INCURRED DURING CONSTRUCTION OPERATIONS AT HIS EXPENSE.
- ALL VALVES AND MANHOLE COVERS SHALL BE RAISED OR LOWERED TO MEET FINISHED GRADE.
- CONTRACTOR SHALL CUT PIPES OFF FLUSH WITH THE INSIDE WALL OF THE BOX OR MANHOLE.
- CONTRACTOR SHALL GROUT AT CONNECTION OF PIPE TO BOX WITH NON-SHRINKING GROUT, INCLUDING PIPE VOIDS LEFT BY CUTTING PROCESS, TO A SMOOTH FINISH.
- CONTRACTOR SHALL GROUT WITH NON-SHRINK GROUT BETWEEN GRADE RINGS AND BETWEEN BOTTOM OF INLET LID FRAME AND TOP OF CONCRETE BOX.
- SILT AND DEBRIS IS TO BE CLEANED OUT OF ALL STORM DRAIN BOXES. CATCH BASINS ARE TO BE MAINTAINED IN A CLEANED CONDITION AS NEEDED UNTIL AFTER THE FINAL BOND RELEASE INSPECTION.
- CONTRACTOR SHALL CLEAN ASPHALT, TAR OR OTHER ADHESIVES OFF OF ALL MANHOLE LIDS AND INLET GRATES TO ALLOW ACCESS.
- EACH TRENCH SHALL BE EXCAVATED SO THAT THE PIPE CAN BE LAID TO THE ALIGNMENT AND GRADE AS REQUIRED. THE TRENCH WALL SHALL BE SO BRACED THAT THE WORKMEN MAY WORK SAFELY AND EFFICIENTLY. ALL TRENCHES SHALL BE DRAINED SO THE PIPE LAYING MAY TAKE PLACE IN DEWATERED CONDITIONS. THE CONTRACTOR IS SOLELY RESPONSIBLE FOR THE COST OF DEWATERING AND NO COST CHANGE WILL BE PROVIDED.
- CONTRACTOR SHALL PROVIDE AND MAINTAIN AT ALL TIMES AMPLE MEANS AND DEVICES WITH WHICH TO REMOVE PROMPTLY AND TO PROPERLY DISPOSE OF ALL WATER ENTERING THE TRENCH EXCAVATION.
- MAINTAIN A MINIMUM 18" VERTICAL SEPARATION DISTANCE BETWEEN ALL UTILITY CROSSINGS. AT WATER/SEWER CROSSINGS, WATER IS REQUIRED TO CROSS ABOVE SANITARY SEWER UNLESS AN EXCEPTION HAS BEEN GRANTED BY THE UTAH DIVISION OF DRINKING WATER.
- CONTRACTOR SHALL START INSTALLATION AT LOW POINT OF ALL NEW GRAVITY UTILITY LINES.
- ALL BOLTED FITTINGS MUST BE GREASED AND WRAPPED.
- UNLESS SPECIFICALLY NOTED OTHERWISE, MAINTAIN AT LEAST 2 FEET OF COVER OVER ALL STORM DRAIN LINES AT ALL TIMES (INCLUDING DURING CONSTRUCTION).
- ALL WATER LINES SHALL BE INSTALLED A MINIMUM OF 108" OF COVER TO TOP OF PIPE BELOW FINISHED GRADE.
- ALL SEWER LINES AND SEWER SERVICES SHALL HAVE A MINIMUM HORIZONTAL SEPARATION OF 10 FEET, PIPE EDGE TO PIPE EDGE, FROM THE WATER LINES.
- CONTRACTOR SHALL INSTALL THRUST BLOCKING AT ALL WATERLINE ANGLE POINTS AND TEES.
- ALL UNDERGROUND UTILITIES SHALL BE IN PLACE PRIOR TO INSTALLATION OF CURB, GUTTER, SIDEWALK AND STREET PAVING.
- CONTRACTOR SHALL INSTALL MAGNETIC LOCATING TAPE CONTINUOUSLY OVER ALL NONMETALLIC PIPE.
- THE CONTRACTOR SHALL NOTIFY TALISMAN CIVIL CONSULTANTS, LLC. IN WRITING AT LEAST 48 HOURS PRIOR TO BACKFILLING OF ANY PIPE WHICH STUBS TO A FUTURE PHASE OF CONSTRUCTION FOR INVERT VERIFICATION. TOLERANCE SHALL BE IN ACCORDANCE WITH THE REGULATORY AGENCY STANDARD SPECIFICATIONS.
- UNDER NO CIRCUMSTANCE SHALL THE PIPE OR ACCESSORIES BE DROPPED INTO THE TRENCH.
- THE CONTRACTOR SHALL MARK ALL UNDERGROUND UTILITIES IN LOCATIONS WHERE UTILITIES ARE NOT LOCATED WITHIN A ROADWAY. THE CONTRACTOR SHALL MARK UTILITIES AT ANGLE POINTS, PCs, AND Pts WITH A 2" REBAR STAKE INSTALLED FLUSH TO GRADE. SURVEY ALL LOCATIONS AND PROVIDE GPS COORDINATES WITH AS-BUILT DRAWINGS.
- ANY CHANGES TO THE ROAD GRADE OR PROFILE NEED TO BE APPROVED BY POWDER MOUNTAIN, AS THIS MAY AFFECT THE FINAL BURY DEPTH OF WATER LINES.
- PROVIDE AND INSTALL FIRE HYDRANT IDENTIFICATION FLAGS ON ALL FIRE HYDRANTS WITHIN PROJECT PER POWDER MOUNTAIN RECOMMENDATIONS.
- ALL FLUSHING SHALL BE OVERSEEN BY PMWSID. PROVIDE 48 HOURS NOTICE PRIOR TO FLUSHING.
- ALL WORK ON WATER AND SEWER INFRASTRUCTURE REQUIRES INSPECTION BY PMWSID. PROVIDE 48 HOURS NOTICE PRIOR TO WORK COMMENCEMENT.
- NO CONSTRUCTION WATER SHALL BE TAKEN FROM THE EXISTING WATER SYSTEM WITHOUT APPROVAL FROM THE DISTRICT.

LEGEND:

SYMBOL / LINETYPE	DESCRIPTION	DETAIL
8"W PVC		
10"W PVC		
8"W HDPE		
10"W HDPE		
12"W HDPE		
2"W		
8"SS PVC		
4"SS-P		
15"SD		
18"SD		
42"CDM		
6" P		
8"W		
16"W		
15"SD		
8"SS		
4" P		
42"CDM		
8"SS HDPE		
15"SD		
16"W		

EROSION CONTROL GENERAL NOTES:

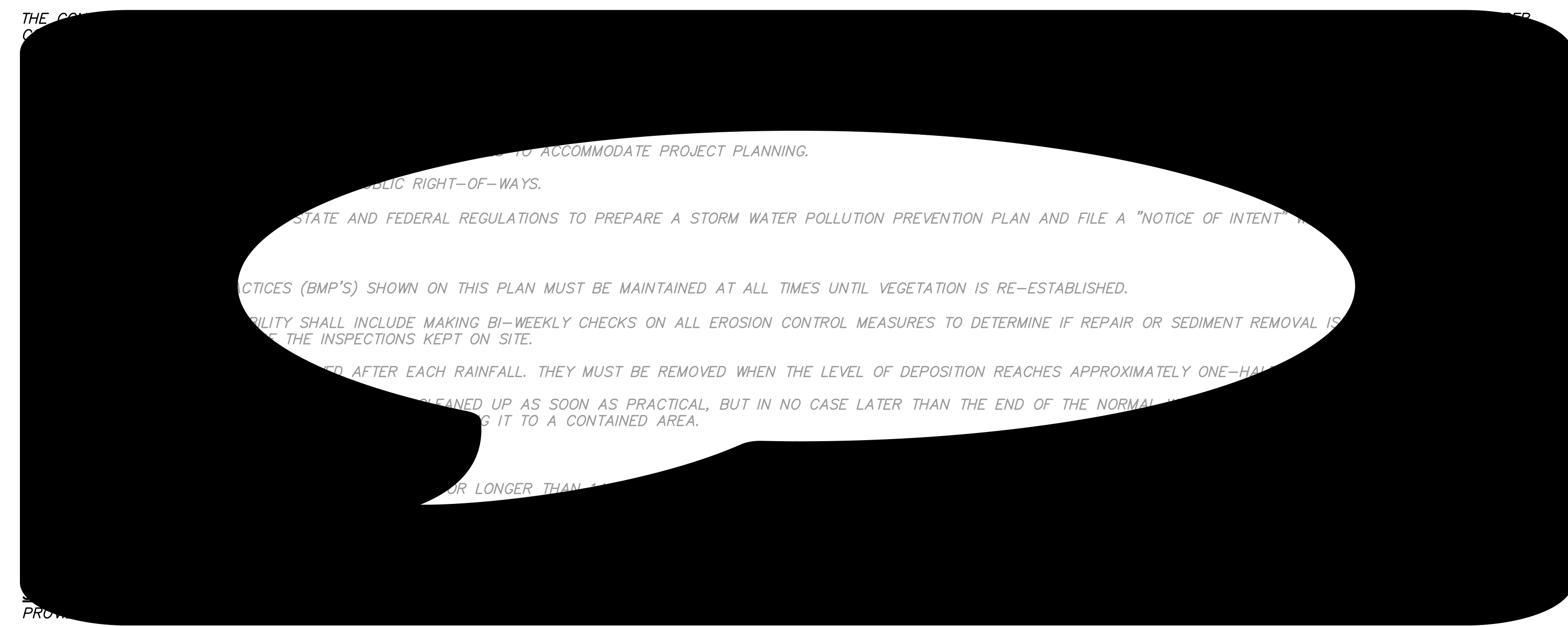

CULINARY WATER NOTES

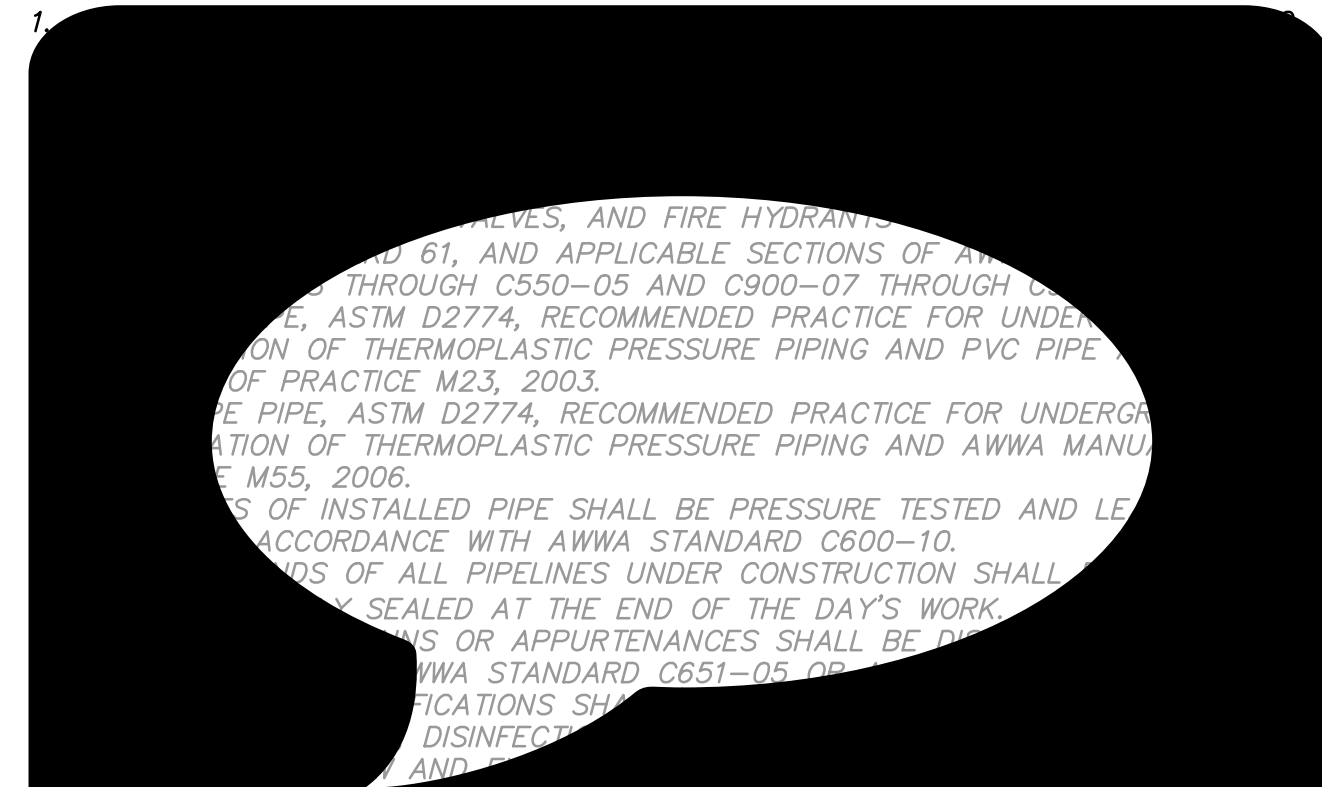

WEBER COUNTY

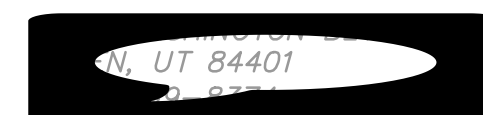

ROCKY MOUNTIAN POWER



POWDER MOUNTAIN WATER & SEWER DISTRICT

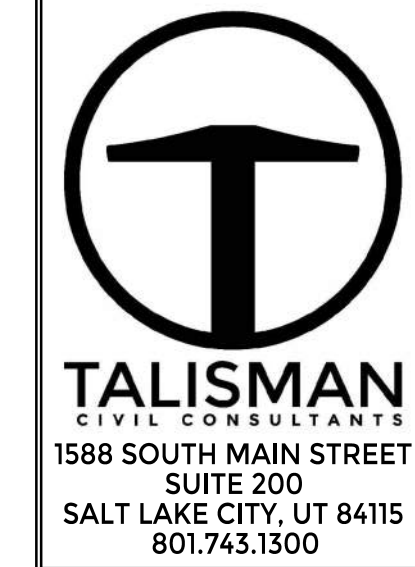

POWDER POINT POWDER MOUNTAIN, UTAH GENERAL NOTES

DATE: 06.29.2023

TCC JOB NUMBER: 22-126

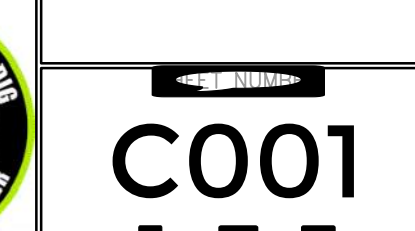
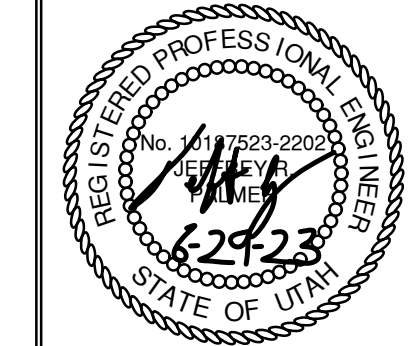

C001



DATE: 06.29.2023

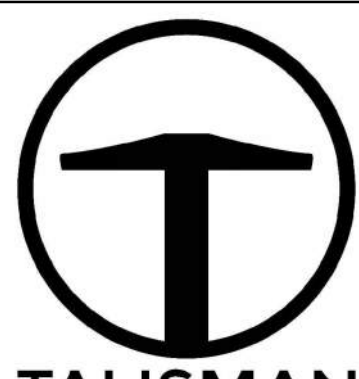

**TALISMAN**  
CIVIL CONSULTANTS  
1588 SOUTH MAIN STREET  
SUITE 200  
SALT LAKE CITY, UT 84115  
801.743.1500



DATE: 06.29.2023

**POWDER POINT  
POWDER MOUNTAIN, UTAH  
TYPICAL ROAD AND PAVEMENT SECTIONS**

TCC JOB NUMBER: 22-126

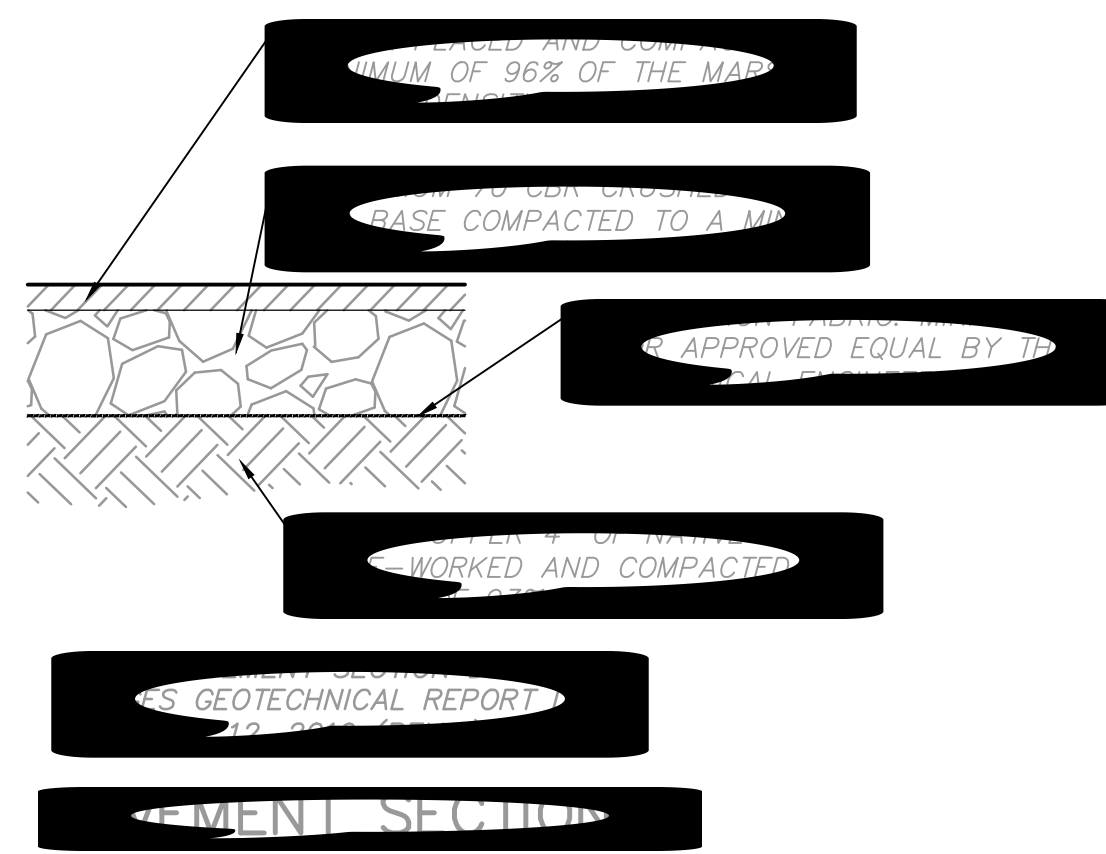
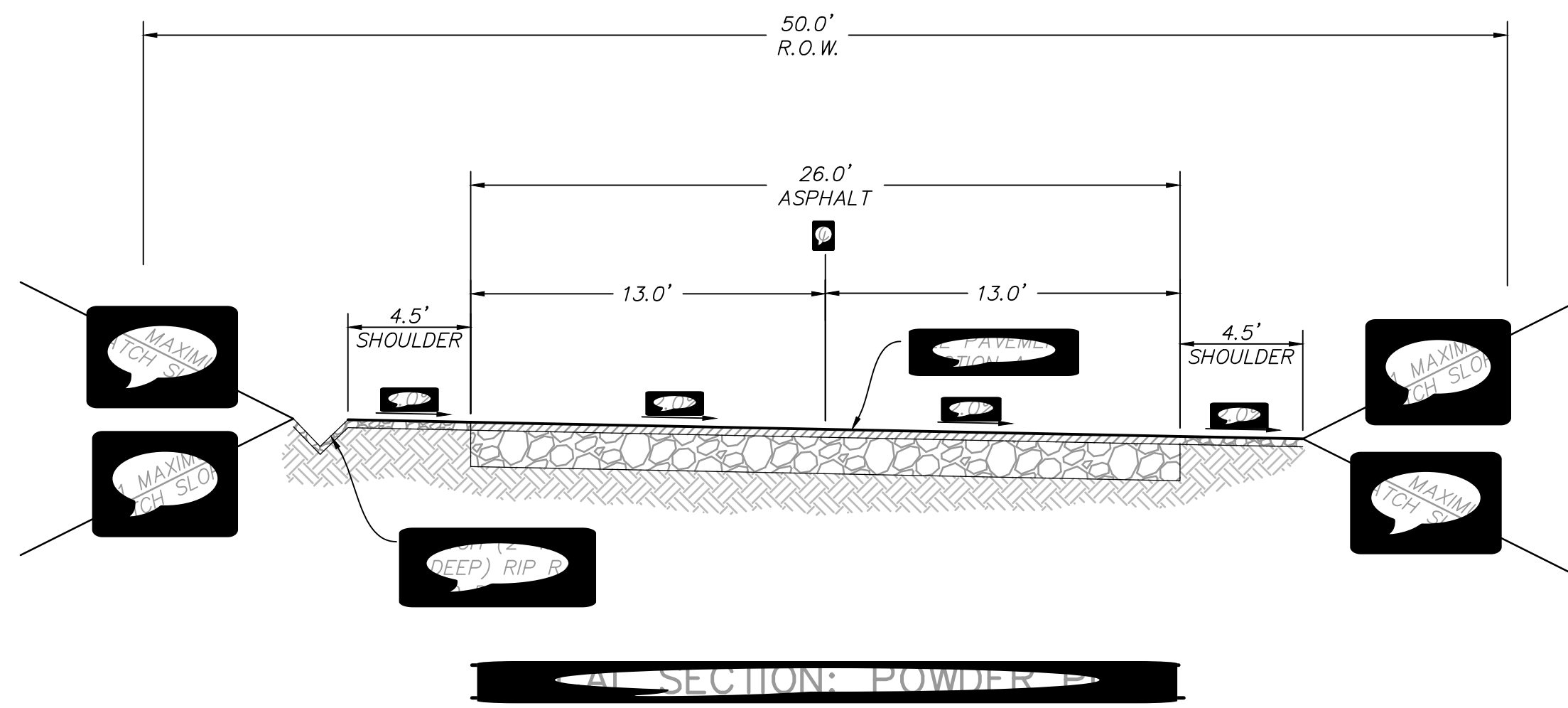

**C002**





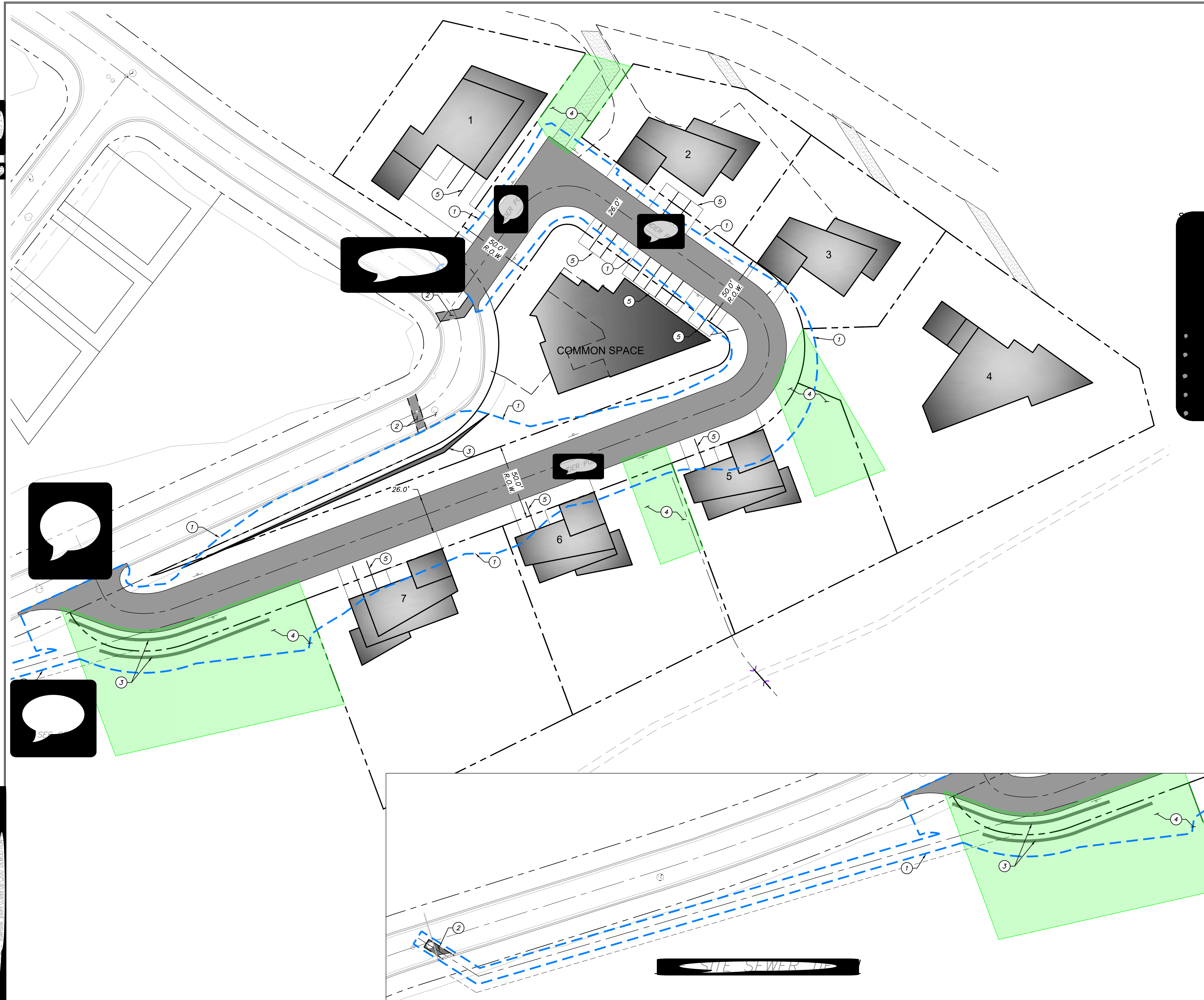

PARTICIPATED ON THIS PROJECT  
 FOOTPRINTS ARE SHOWN FOR REFERENCE ONLY  
**SCOPE OF WORK:**  
 INSTALL AND/OR CONSTRUCT THE FOLLOWING PER THE  
 CONDITIONS GIVEN OR REFERENCED, THE DETAILS NOTED,  
 AND THE NOTES ON THE CONSTRUCTION DRAWINGS:  
 1. ESTIMATE LIMITS OF DISTURBANCE.  
 2. REMOVE ASPHALT TO INSTALL NEW  
 PAVEMENT SECTION.  
 3. REPAIR STRIP...

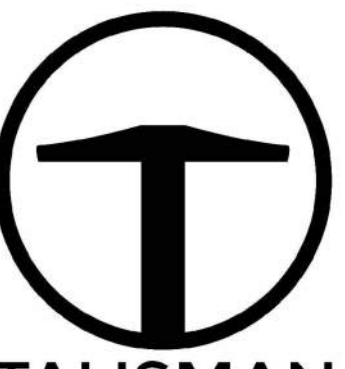
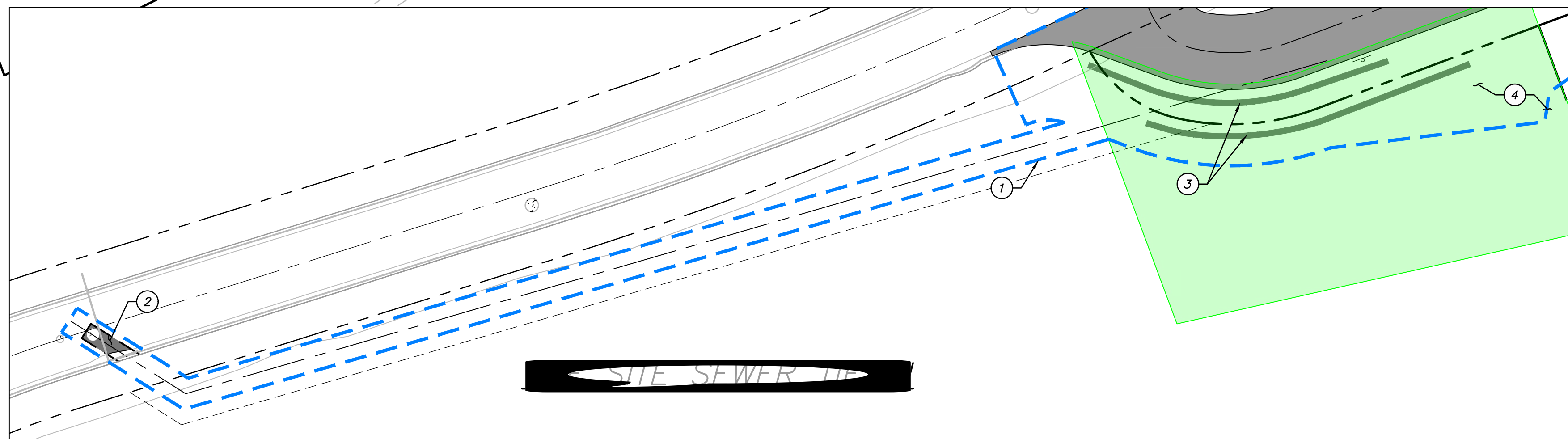

**TALISMAN**  
 CIVIL CONSULTANTS  
 1588 SOUTH MAIN STREET  
 SUITE 200  
 SALT LAKE CITY, UT 84115  
 801.743.1300

--	--	--	--	--	--	--	--	--	--	--	--	--	--	--	--	--	--	--	--

**POWDER POINT**  
 POWDER MOUNTAIN, UTAH  
 DEMOLITION AND SITE PLAN  
 TCC JOB NUMBER: 22-126

DATE: 06.29.2023

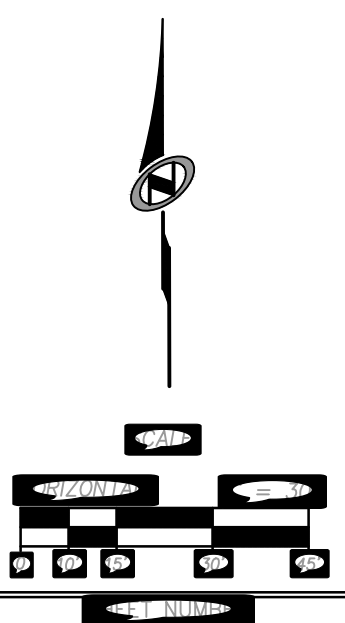

**C200**



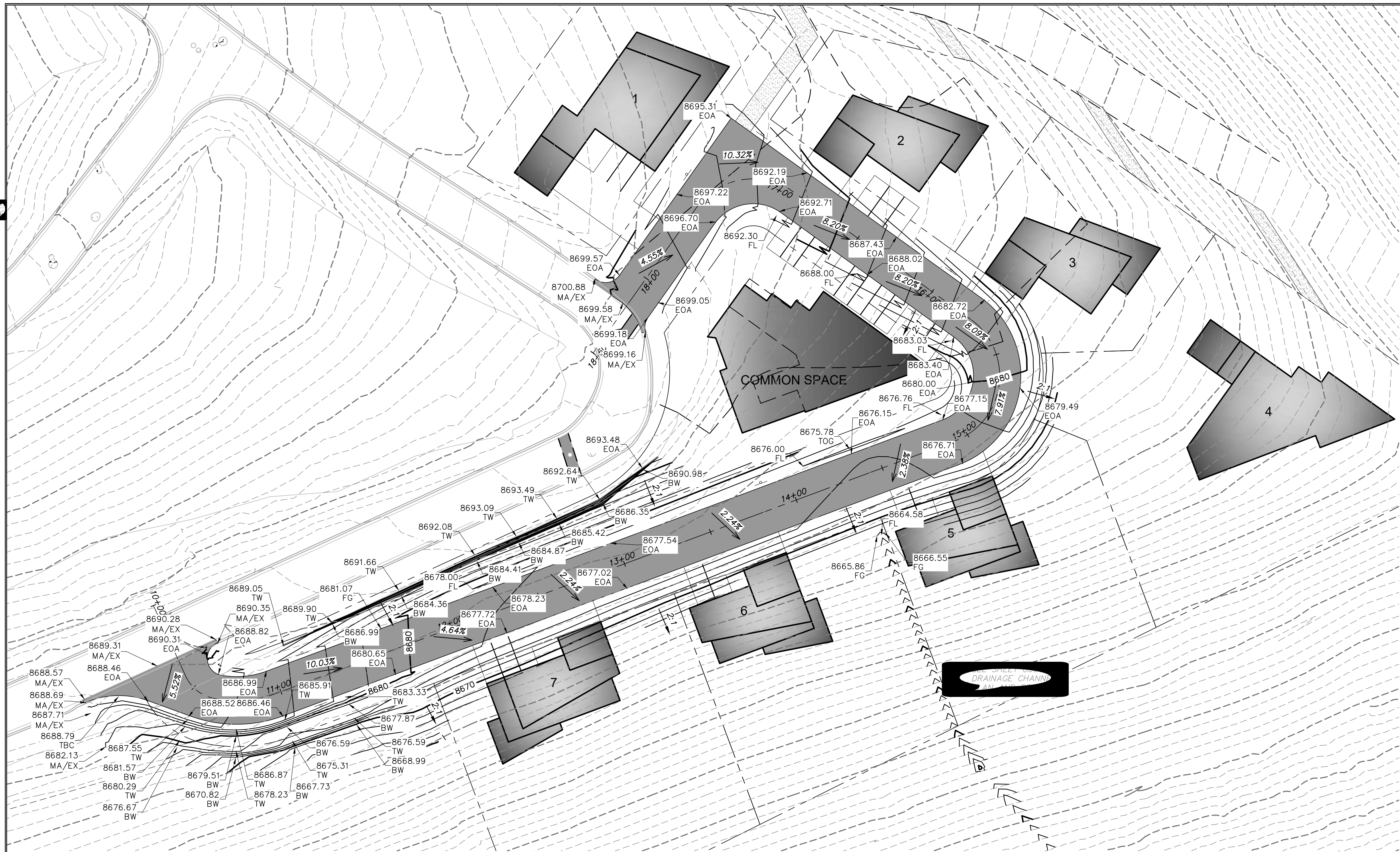

**GRADING GENERAL NOTES:**

- SEE SHEET C500 FOR PLAN AND PROFILE OF ROAD.
- SITE GRADING SHALL BE PERFORMED IN ACCORDANCE WITH THESE PLANS AND SPECIFICATIONS. THE CONTRACTOR SHALL BE RESPONSIBLE FOR REMOVING AND REPLACING ALL SOFT, YIELDING OR UNSUITABLE MATERIALS AND REPLACING THEM WITH SUITABLE MATERIALS. ALL EXCAVATED OR FILLED AREAS SHALL BE COMPACTED TO 95% OF MODIFIED PROCTOR MAXIMUM DENSITY PER ASTM TEST D-1557. MOISTURE CONTENT AT TIME OF PLACEMENT SHALL NOT EXCEED 2% ABOVE NOR 3% BELOW OPTIMUM. CONTRACTOR SHALL SUBMIT A COMPACTION REPORT PREPARED BY A QUALIFIED REGISTERED GEOTECHNICAL ENGINEER, VERIFYING THAT ALL FILLED AREAS AND SUBGRADE AREAS TO BE PAVED HAVE BEEN COMPACTED IN ACCORDANCE WITH THESE PLANS AND SPECIFICATIONS.
- CONTRACTOR SHALL BECOME FAMILIAR WITH EXISTING SOIL CONDITIONS.
- THE CONTRACTOR IS TO USE BEST MANAGEMENT PRACTICES FOR PROVIDING EROSION CONTROL AND DUST SUPPRESSION FOR CONSTRUCTION OF THIS PROJECT.
- EXISTING UNDERGROUND UTILITIES AND IMPROVEMENTS ARE SHOWN IN THEIR APPROXIMATE LOCATIONS BASED UPON RECORD INFORMATION AVAILABLE AT THE TIME OF PREPARATION OF PLANS. LOCATIONS MAY NOT HAVE BEEN VERIFIED IN THE FIELD AND NO GUARANTEE IS MADE AS TO ACCURACY OR COMPLETENESS OF THE INFORMATION SHOWN. IT SHALL BE THE RESPONSIBILITY OF THE CONTRACTOR TO DETERMINE THE EXISTENCE AND LOCATION OF THOSE UTILITIES SHOWN ON THESE PLANS OR INDICATED IN THE FIELD BY LOCATING SERVICES. ANY ADDITIONAL COSTS INCURRED AS A RESULT OF CONTRACTOR'S FAILURE TO VERIFY LOCATIONS OF EXISTING UTILITIES PRIOR TO BEGINNING OF CONSTRUCTION IN THEIR VICINITY SHALL BE BORNE BY THE CONTRACTOR AND ASSUMED INCLUDED IN THE CONTRACT.
- LOCATIONS OF ALL UNDERGROUND UTILITIES SHOWN ARE APPROXIMATE. CONTRACTOR IS TO VERIFY CONNECTION POINTS WITH EXISTING UTILITIES. CONTRACTOR IS RESPONSIBLE FOR ANY DAMAGE CAUSED TO EXISTING UTILITIES AND UTILITY STRUCTURES THAT ARE TO REMAIN.
- ALL SURFACE IMPROVEMENTS DISTURBED BY CONSTRUCTION SHALL BE RESTORED OR REPLACED, INCLUDING TREES, DECORATIVE SHRUBS, SOD, FENCES, WALLS AND STRUCTURES, WHETHER OR NOT THEY ARE SPECIFICALLY SHOWN ON THE CONTRACT DOCUMENTS.

**ABBREVIATIONS:**

BS	BOTTOM OF STAIRS
BW	BOTTOM OF WALL
EX	EXISTING GRADE
EP	EDGE OF PAVEMENT
FFE	FINISHED FLOOR ELEVATION
FG	FINISHED GRADE
GB	GRADE BREAK
MA	MATCH
SW	EDGE OF SIDEWALK
TBC	TOP BACK OF CURB
TOA	TOP OF ASPHALT
TS	TOP OF STAIRS
TW	TOP OF WALL

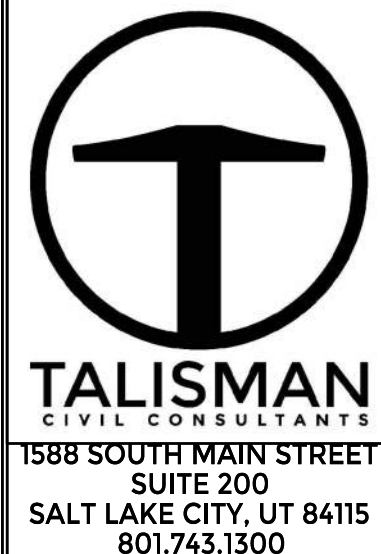
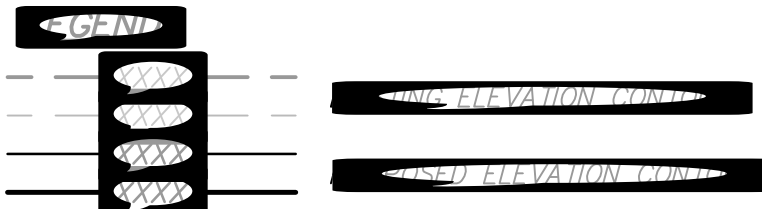

**POWDER POINT  
POWDER MOUNTAIN, UTAH  
GRADING PLAN**

DATE: 06.29.2023

TCC JOB NUMBER: 22-126

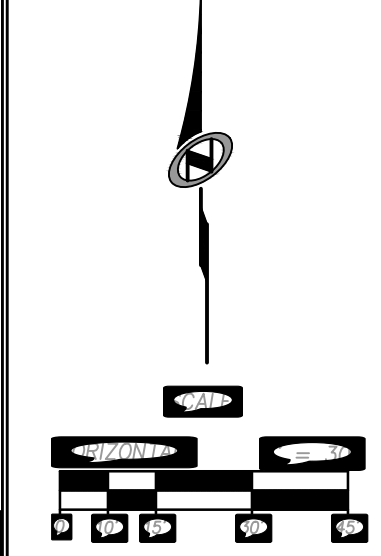
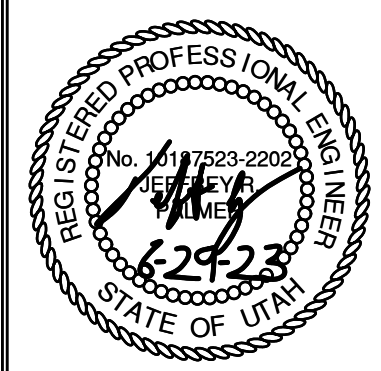

**C300**











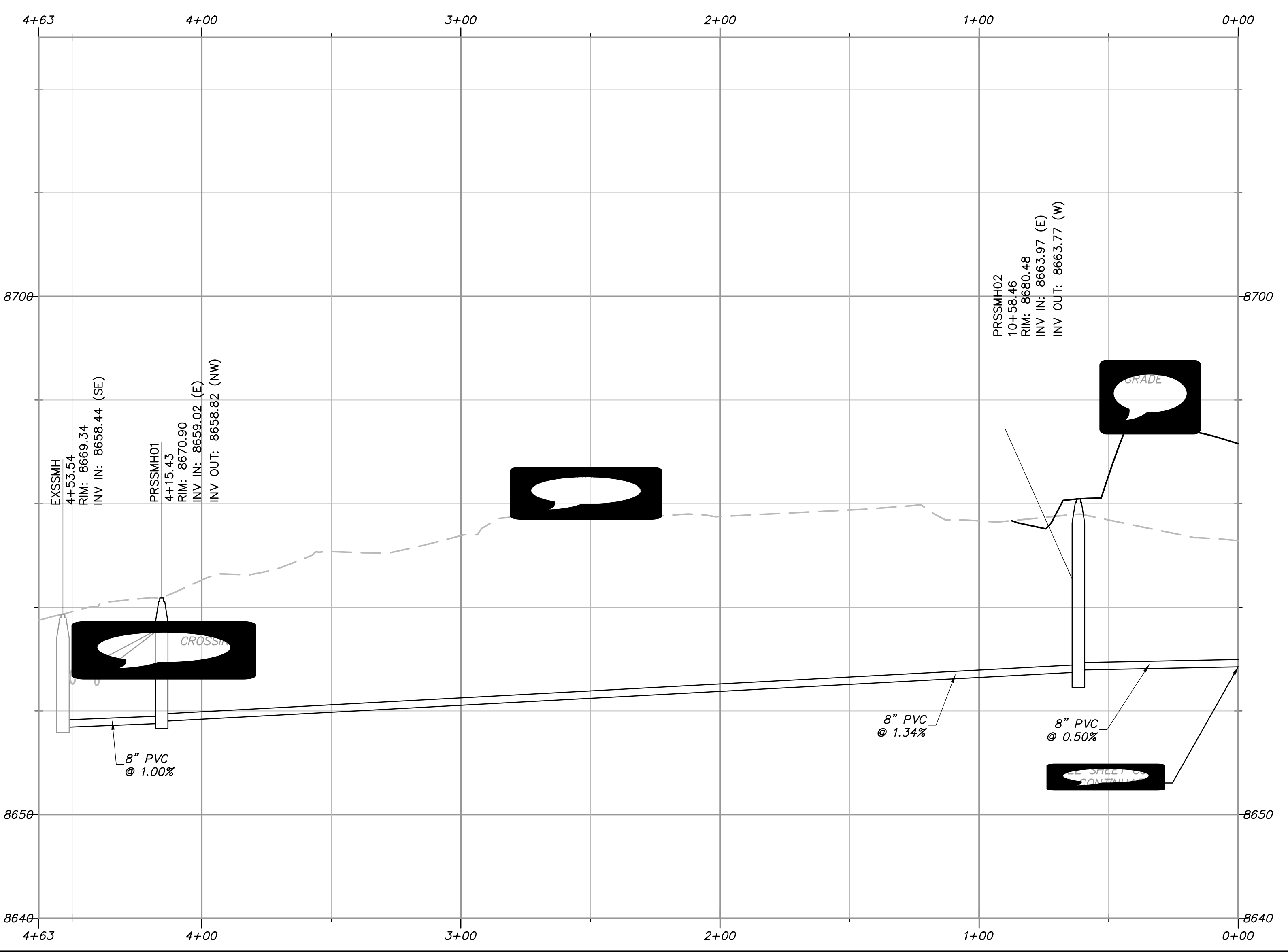
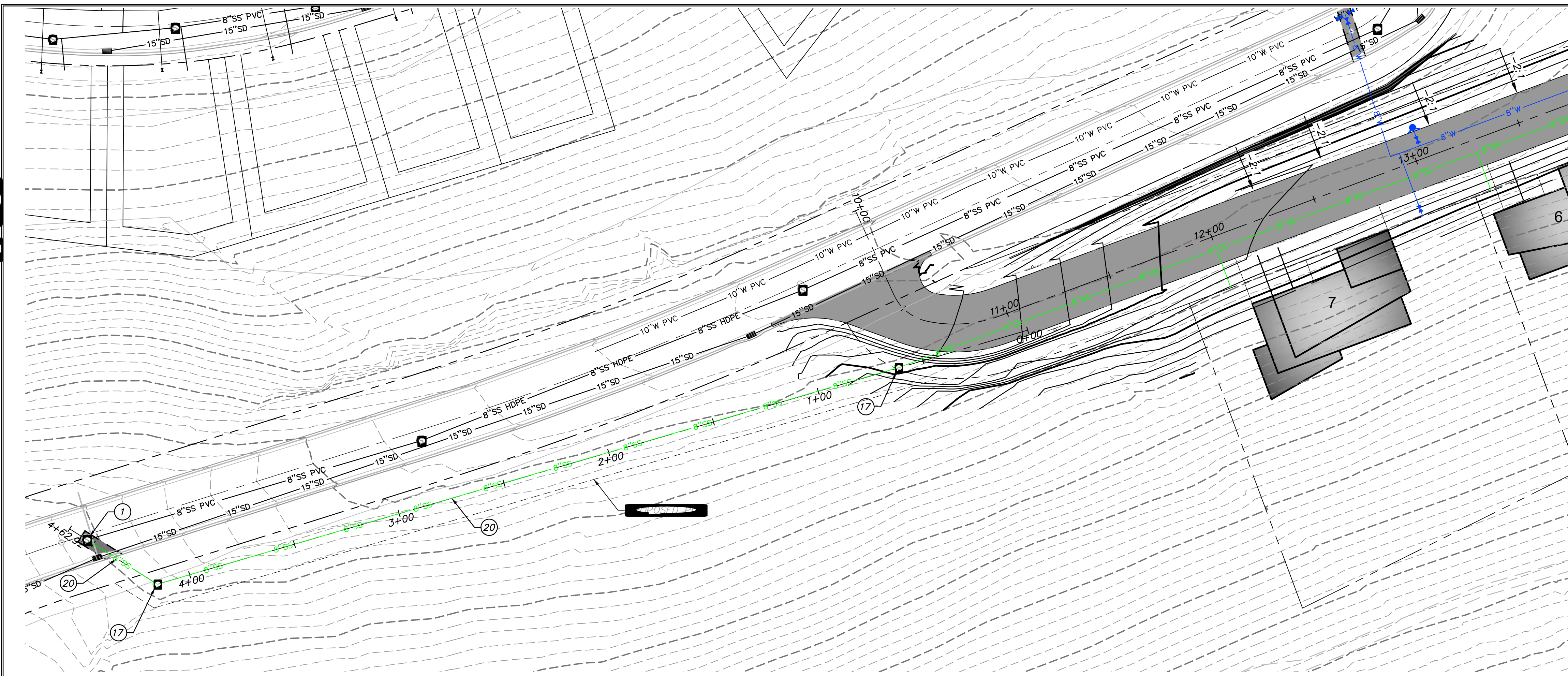

THE FIELD AND COMPLETENESS OF THE INFORMATION AND LOCATION OF THOSE UTILITIES SHOWN ON THE DRAWINGS IS THE RESPONSIBILITY OF THE CONTRACTOR TO VERIFY IN THE FIELD BY LOCATING SERVICES. ANY DAMAGE TO EXISTING UTILITIES PRIOR TO BEGINNING OF CONSTRUCTION SHALL BE BORNE BY THE CONTRACTOR AND NOT THE OWNER. THE CONTRACTOR IS TO VERIFY CONNECTION POINTS WITH EXISTING UTILITIES AND UTILITY STRUCTURES THAT ARE TO BE REMOVED OR REPLACED, INCLUDING TREES, DECORATIVE STRUCTURES, WHETHER OR NOT SHOWN ON THE CONTRACT DOCUMENTS. SEE SHEETS C500 & C501.

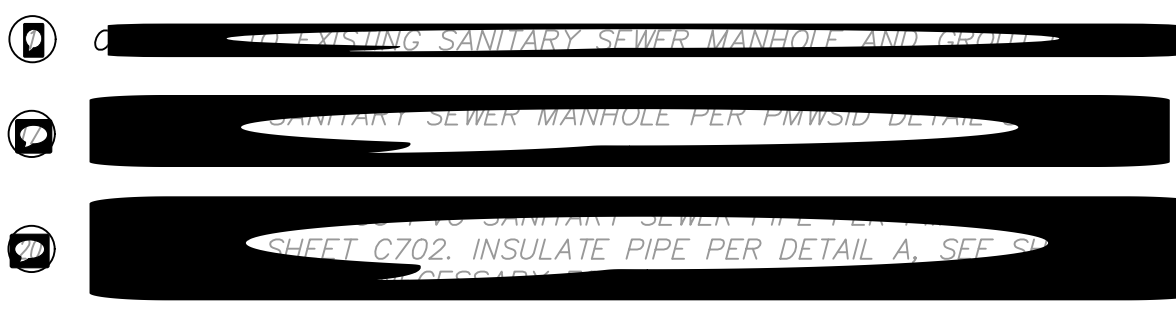

CONTRACTOR SHALL FIELD VERIFY LOCATIONS AND DEPTHS OF EXISTING MANHOLES AND OTHER UTILITIES PRIOR TO BEGINNING OF CONSTRUCTION. THE CONTRACTOR SHALL COMPLY TO THE SPECIFICATIONS AND DRAWINGS FOR ALL UTILITIES AND SEWER LINES.

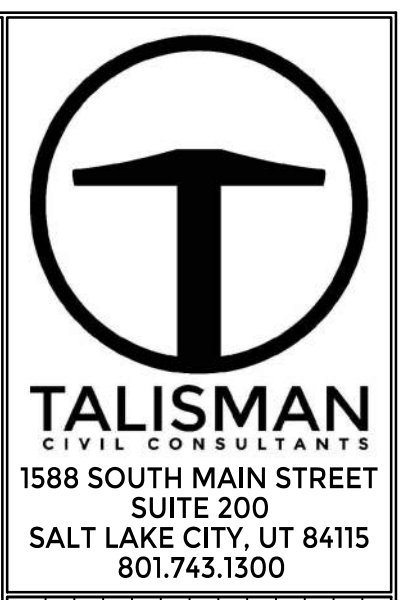

**POWDER POINT**  
**POWDER MOUNTAIN, UTAH**  
**OFFSITE SEWER LINE PLAN AND PROFILE**  
 TCC JOB NUMBER: 22-126  
 DATE: 06.29.2023



**811**  
 CALL BEFORE YOU DIG  
 SAFE DIGGING PROGRAM



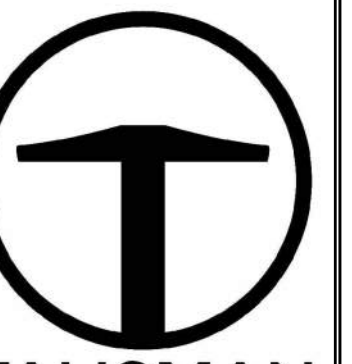

**TALISMAN**  
CIVIL CONSULTANTS  
1588 SOUTH MAIN STREET  
SUITE 200  
SALT LAKE CITY, UT 84115  
801.743.1300

DATE: 06.29.2023

**POWDER POINT  
POWDER MOUNTAIN, UTAH  
DRAINAGE CHANNEL PLAN & PROFILES**

TCC JOB NUMBER: 22-126

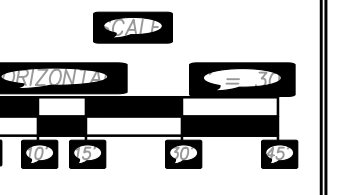
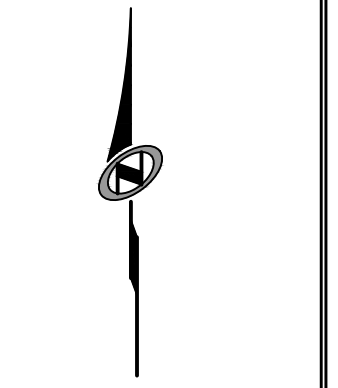
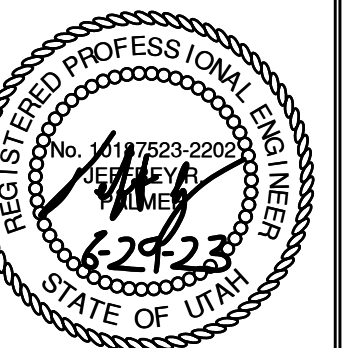

**C502**

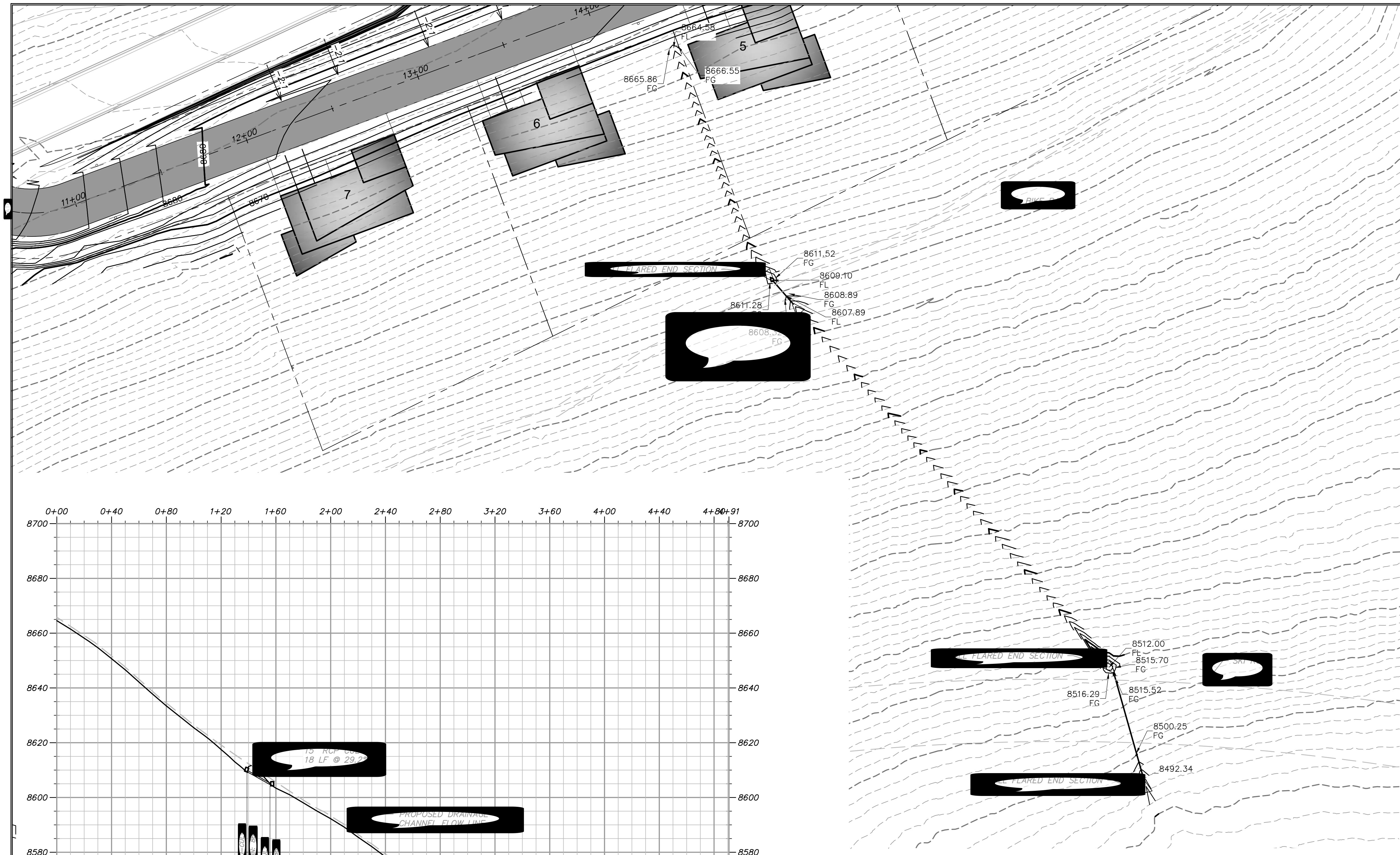

**GRADING GENERAL NOTES:**

- SEE SHEET C500 FOR PLAN AND PROFILE OF ROAD.
- SITE GRADING SHALL BE PERFORMED IN ACCORDANCE WITH THESE PLANS AND SPECIFICATIONS. THE CONTRACTOR SHALL BE RESPONSIBLE FOR REMOVING AND REPLACING ALL SOFT, YIELDING OR UNSUITABLE MATERIALS AND REPLACING THEM WITH SUITABLE MATERIALS. ALL EXCAVATED OR FILLED AREAS SHALL BE COMPACTED TO 95% OF MODIFIED PROCTOR MAXIMUM DENSITY PER ASTM TEST D-1557. MOISTURE CONTENT AT TIME OF PLACEMENT SHALL NOT EXCEED 2% ABOVE NOR 3% BELOW OPTIMUM. CONTRACTOR SHALL SUBMIT A COMPACTION REPORT PREPARED BY A QUALIFIED REGISTERED GEOTECHNICAL ENGINEER, VERIFYING THAT ALL FILLED AREAS AND SUBGRADE AREAS TO BE PAVED HAVE BEEN COMPACTED IN ACCORDANCE WITH THESE PLANS AND SPECIFICATIONS.
- CONTRACTOR SHALL BECOME FAMILIAR WITH EXISTING SOIL CONDITIONS.
- THE CONTRACTOR IS TO USE BEST MANAGEMENT PRACTICES FOR PROVIDING EROSION CONTROL AND DUST SUPPRESSION FOR CONSTRUCTION OF THIS PROJECT.
- EXISTING UNDERGROUND UTILITIES AND IMPROVEMENTS ARE SHOWN IN THEIR APPROXIMATE LOCATIONS BASED UPON RECORD INFORMATION AVAILABLE AT THE TIME OF PREPARATION OF PLANS. LOCATIONS MAY NOT HAVE BEEN VERIFIED IN THE FIELD AND NO GUARANTEE IS MADE AS TO ACCURACY OR COMPLETENESS OF THE INFORMATION SHOWN. IT SHALL BE THE RESPONSIBILITY OF THE CONTRACTOR TO DETERMINE THE EXISTENCE AND LOCATION OF THOSE UTILITIES SHOWN ON THESE PLANS OR INDICATED IN THE FIELD BY LOCATING SERVICES. ANY ADDITIONAL COSTS INCURRED AS A RESULT OF CONTRACTOR'S FAILURE TO VERIFY LOCATIONS OF EXISTING UTILITIES PRIOR TO BEGINNING OF CONSTRUCTION IN THEIR VICINITY SHALL BE BORNE BY THE CONTRACTOR AND ASSUMED INCLUDED IN THE CONTRACT.
- LOCATIONS OF ALL UNDERGROUND UTILITIES SHOWN ARE APPROXIMATE. CONTRACTOR IS TO VERIFY CONNECTION POINTS WITH EXISTING UTILITIES. CONTRACTOR IS RESPONSIBLE FOR ANY DAMAGE CAUSED TO EXISTING UTILITIES AND UTILITY STRUCTURES THAT ARE TO REMAIN.
- ALL SURFACE IMPROVEMENTS DISTURBED BY CONSTRUCTION SHALL BE RESTORED OR REPLACED, INCLUDING TREES, DECORATIVE SHRUBS, SOD, FENCES, WALLS AND STRUCTURES, WHETHER OR NOT THEY ARE SPECIFICALLY SHOWN ON THE CONTRACT DOCUMENTS.

**ABBREVIATIONS:**

BS	BOTTOM OF STAIRS
BW	BOTTOM OF WALL
EX	EXISTING GRADE
EP	EDGE OF PAVEMENT
FFE	FINISHED FLOOR ELEVATION
FG	FINISHED GRADE
GB	GRADE BREAK
MA	MATCH
SW	EDGE OF SIDEWALK
TBC	TOP BACK OF CURB
TOA	TOP OF ASPHALT
TS	TOP OF STAIRS
TW	TOP OF WALL

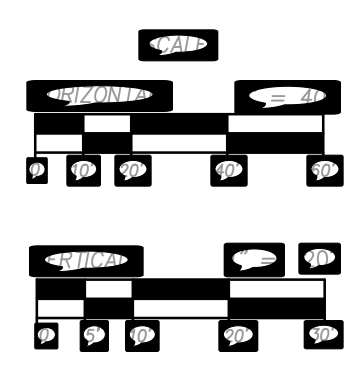
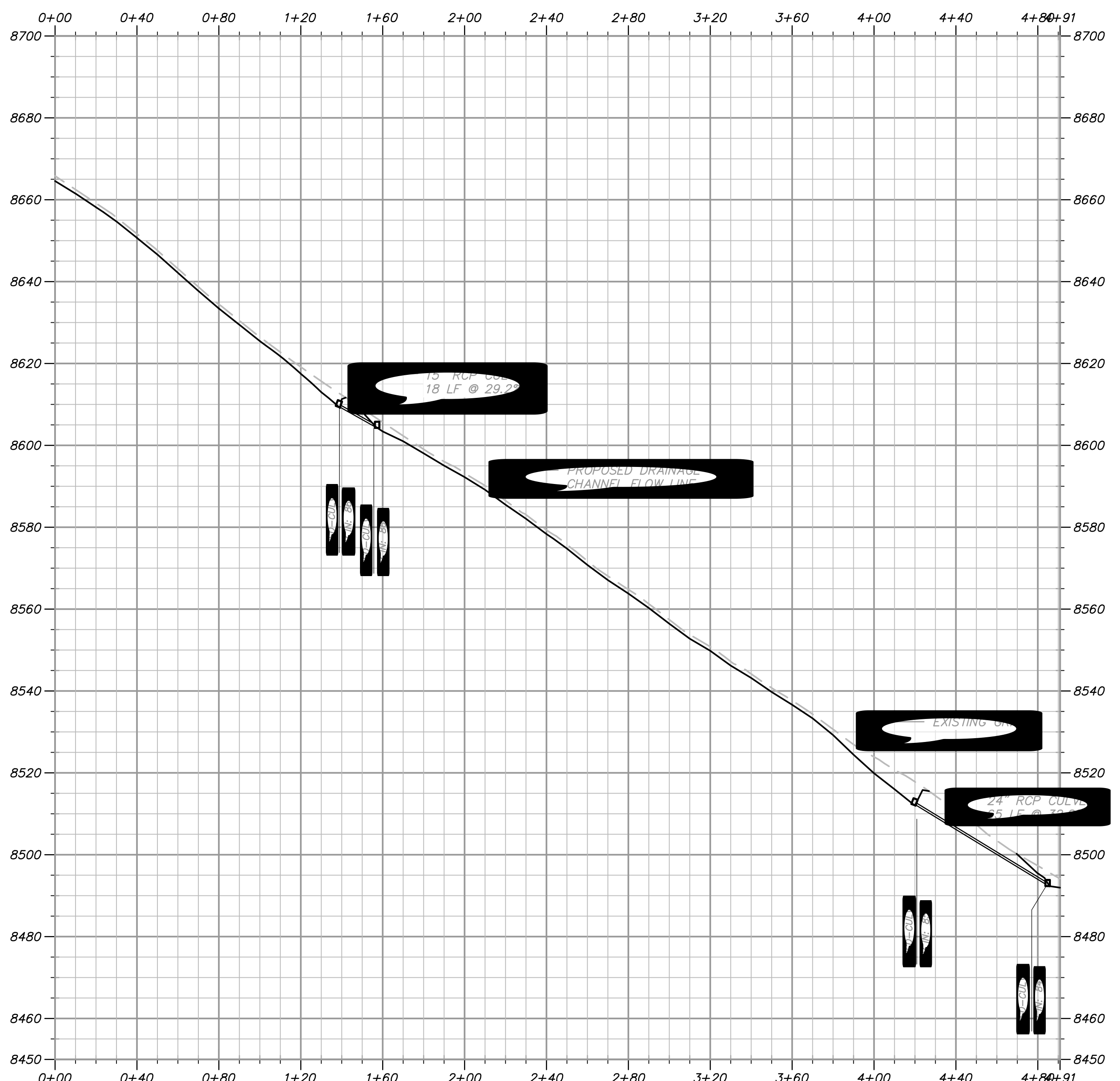
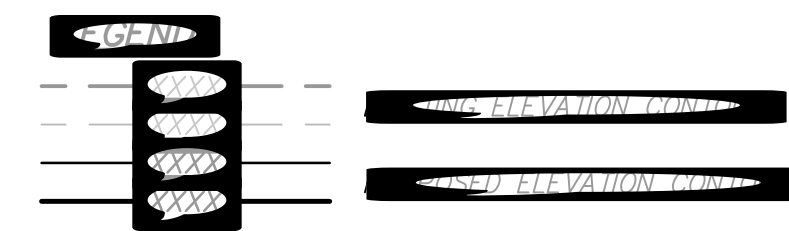



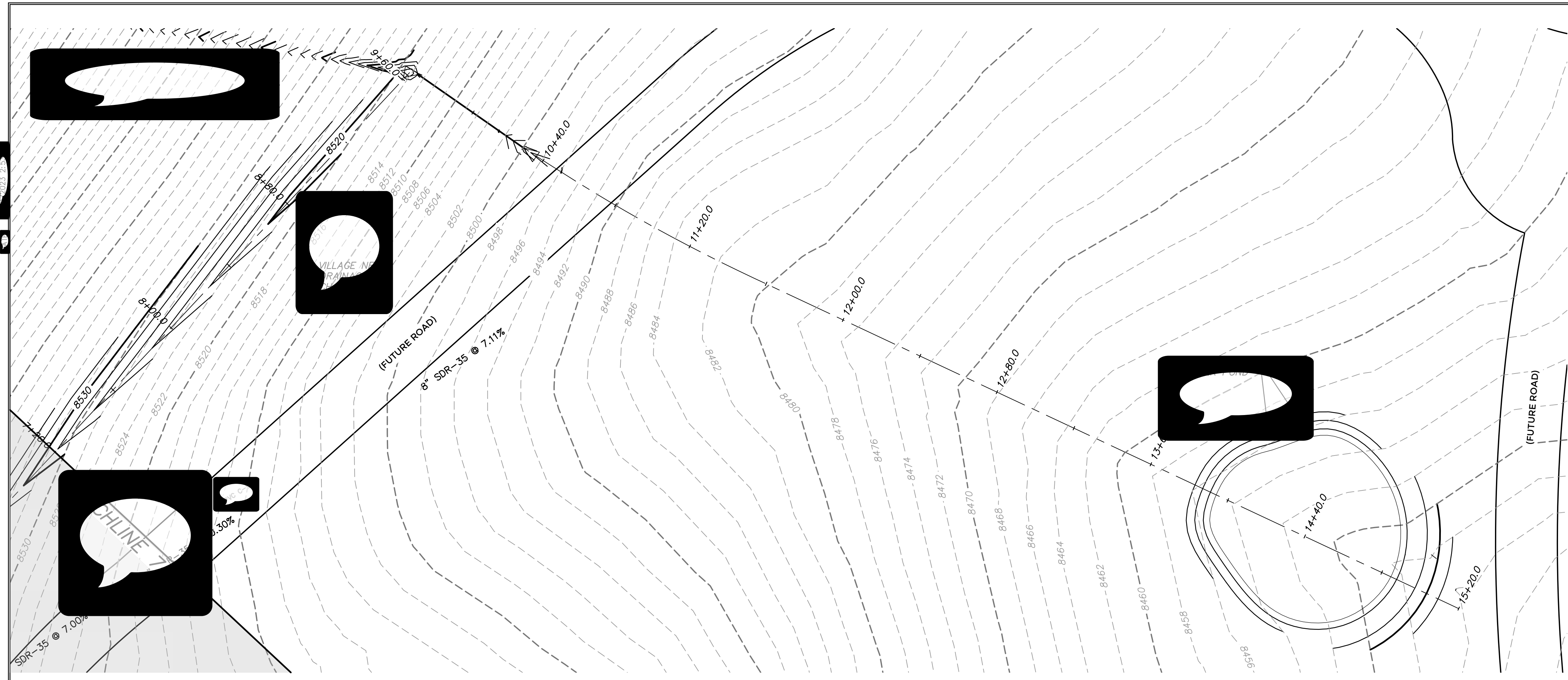

**GRADING GENERAL NOTES:**

1. SITE GRADING SHALL BE PERFORMED IN ACCORDANCE WITH THESE PLANS AND SPECIFICATIONS. THE CONTRACTOR SHALL BE RESPONSIBLE FOR REMOVING AND REPLACING ALL SOFT, YIELDING OR UNSUITABLE MATERIALS AND REPLACING THEM WITH SUITABLE MATERIALS. ALL EXCAVATED OR FILLED AREAS SHALL BE COMPACTED TO 95% OF MODIFIED PROCTOR MAXIMUM DENSITY PER ASTM TEST D-1557. MOISTURE CONTENT AT TIME OF PLACEMENT SHALL NOT EXCEED 2% ABOVE NOR 3% BELOW OPTIMUM. CONTRACTOR SHALL SUBMIT A COMPACTION REPORT PREPARED BY A QUALIFIED REGISTERED GEOTECHNICAL ENGINEER VERIFYING THAT ALL FILLED AREAS AND SUBGRADE AREAS TO BE PAVED HAVE BEEN COMPACTED IN ACCORDANCE WITH THESE PLANS AND SPECIFICATIONS.
2. CONTRACTOR SHALL BECOME FAMILIAR WITH EXISTING SOIL CONDITIONS.
3. THE CONTRACTOR IS TO USE BEST MANAGEMENT PRACTICES FOR PROVIDING EROSION CONTROL AND DUST SUPPRESSION FOR CONSTRUCTION OF THIS PROJECT.
4. EXISTING UNDERGROUND UTILITIES AND IMPROVEMENTS ARE SHOWN IN THEIR APPROXIMATE LOCATIONS BASED UPON RECORD INFORMATION AVAILABLE AT THE TIME OF PREPARATION OF PLANS. LOCATIONS MAY NOT HAVE BEEN VERIFIED IN THE FIELD AND NO GUARANTEE IS MADE AS TO ACCURACY OR COMPLETENESS OF THE INFORMATION SHOWN. IT SHALL BE THE RESPONSIBILITY OF THE CONTRACTOR TO DETERMINE THE EXISTENCE AND LOCATION OF THOSE UTILITIES SHOWN ON THESE PLANS OR INDICATED IN THE FIELD BY LOCATING SERVICES. ANY ADDITIONAL COSTS INCURRED AS A RESULT OF CONTRACTOR'S FAILURE TO VERIFY LOCATIONS OF EXISTING UTILITIES PRIOR TO BEGINNING OF CONSTRUCTION IN THEIR VICINITY SHALL BE BORNE BY THE CONTRACTOR AND ASSUMED INCLUDED IN THE CONTRACT.
5. LOCATIONS OF ALL UNDERGROUND UTILITIES SHOWN ARE APPROXIMATE. CONTRACTOR IS TO VERIFY CONNECTION POINTS WITH EXISTING UTILITIES. CONTRACTOR IS RESPONSIBLE FOR ANY DAMAGE CAUSED TO EXISTING UTILITIES AND UTILITY STRUCTURES THAT ARE TO REMAIN.
6. ALL SURFACE IMPROVEMENTS DISTURBED BY CONSTRUCTION SHALL BE RESTORED OR REPLACED, INCLUDING TREES, DECORATIVE SHRUBS, SOD, FENCES, WALLS AND STRUCTURES, WHETHER OR NOT THEY ARE SPECIFICALLY SHOWN ON THE CONTRACT DOCUMENTS.

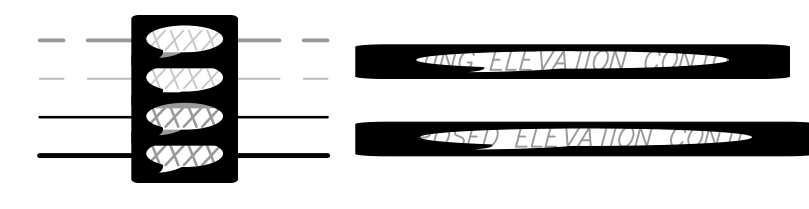

WATER CONVEYANCE DITCH

FOR REFERENCE ONLY, TO BE BUILT FOR VILLAGE NEST IMPROVEMENT

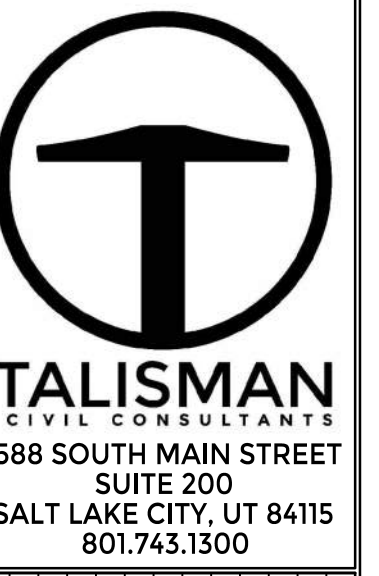
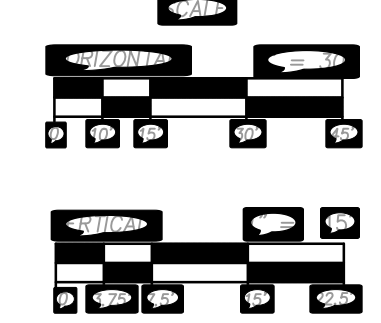
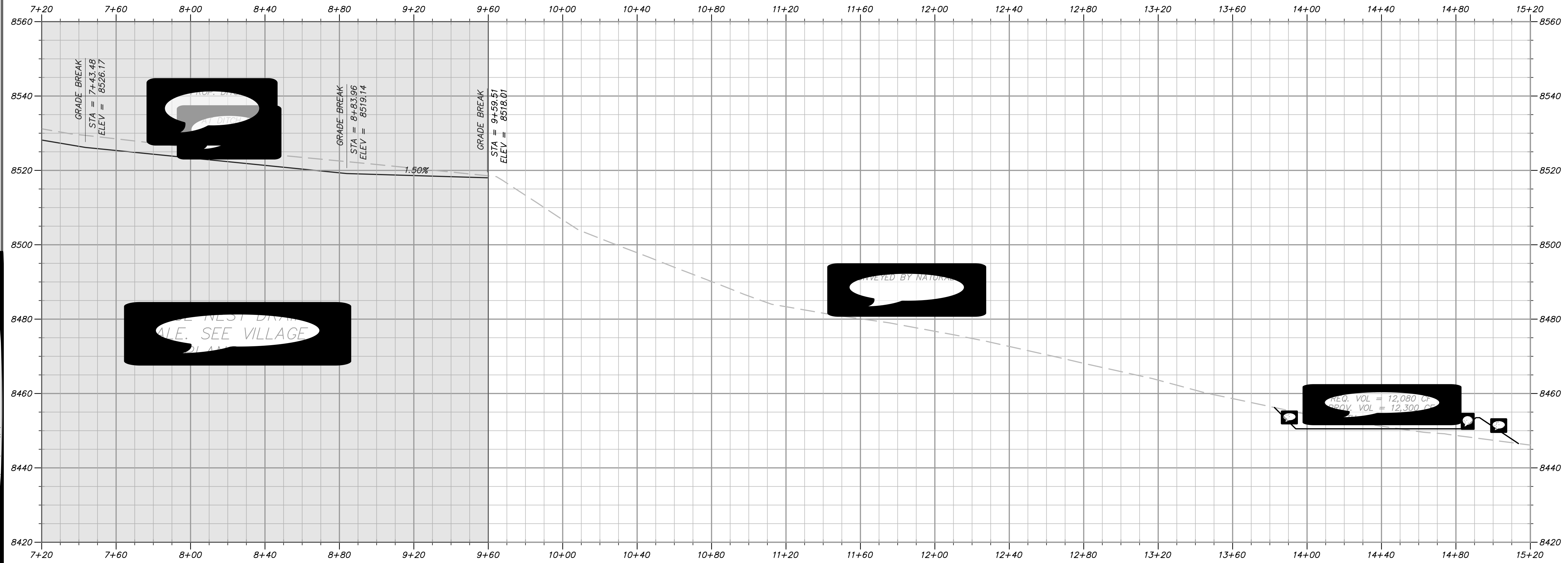

**POWDER POINT  
POWDER MOUNTAIN, UTAH  
STORMWATER CONVEYANCE PLAN AND PROFILE**

TCC JOB NUMBER: 22-126 DATE: 06.29.2023

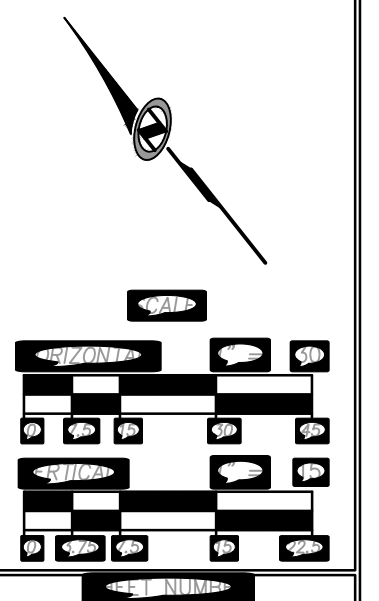
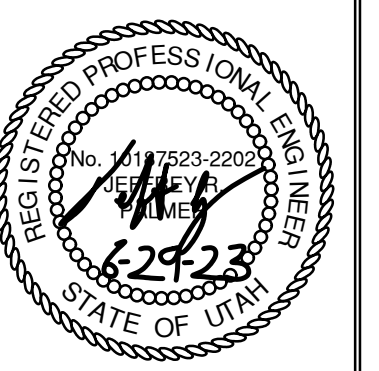

**C503**





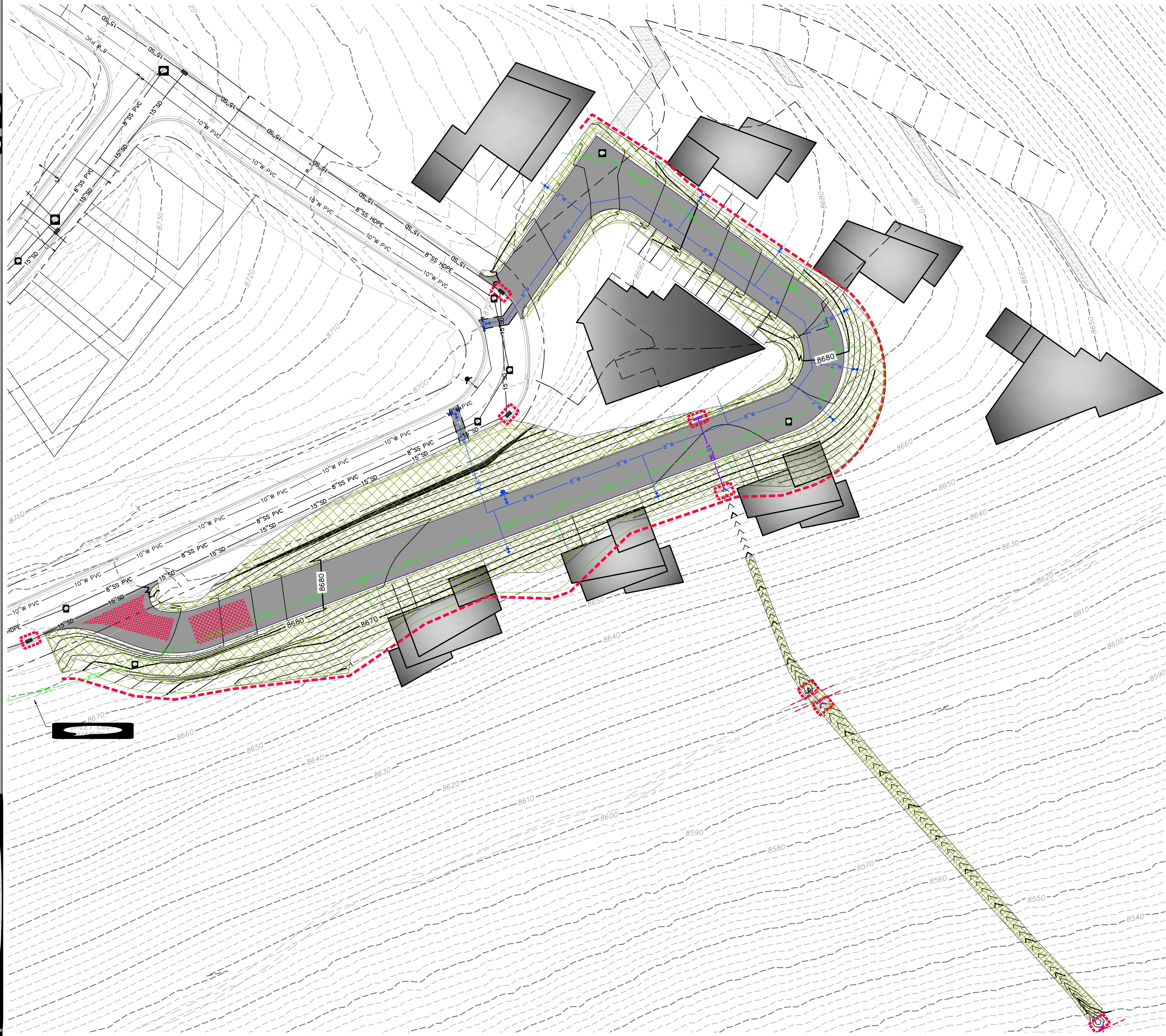

**POWDER POINT  
POWDER MOUNTAIN, UTAH  
EROSION CONTROL PLAN**

TCC JOB NUMBER: 22-126      DATE: 06.29.2023

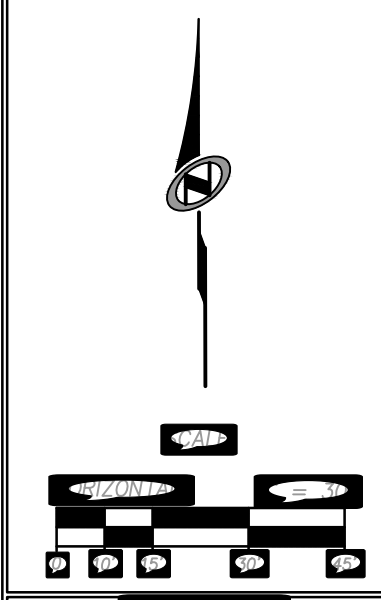
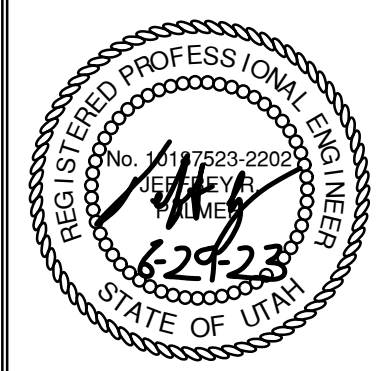

C600

- Symbol: Arrow with '15:50' label
- Symbol: Multiple parallel lines
- Symbol: Dashed red line
- Symbol: Green cross-hatch pattern
- Symbol: Red cross-hatch pattern
- Symbol: Vertical bars
- Symbol: Horizontal bars
- Symbol: Three curved brush pile shapes
- Symbol: Single brush pile shape
- Symbol: Check dam structure
- Symbol: Check dam structure with '15:50' label

Symbol: Three curved brush pile shapes	SEED MIXTURE FOR DISTURBED AREAS WITH A TACKIFIER VIA HYDROSEEDING
Symbol: Single brush pile shape	SEED MIXTURE
Symbol: Check dam structure	MEADOW BROME (RIGOR) 14 lb/AC
Symbol: Check dam structure with '15:50' label	ORCHARD GRASS 10 lb/AC
Symbol: Check dam structure with '15:50' label	LEGUMES (ADAK) 4 lb/AC
Symbol: Check dam structure with '15:50' label	PLANT PERPENDICULAR TO EROSION CONTROL STRUCTURE





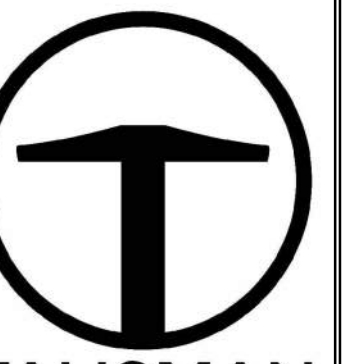

**TALISMAN**  
 CIVIL CONSULTANTS  
 1588 SOUTH MAIN STREET  
 SUITE 200  
 SALT LAKE CITY, UT 84115  
 801.743.1300

**POWDER POINT  
 POWDER MOUNTAIN, UTAH  
 OFFSITE EROSION CONTROL PLAN**

TCC JOB NUMBER: 22-126  
 DATE: 06.29.2023

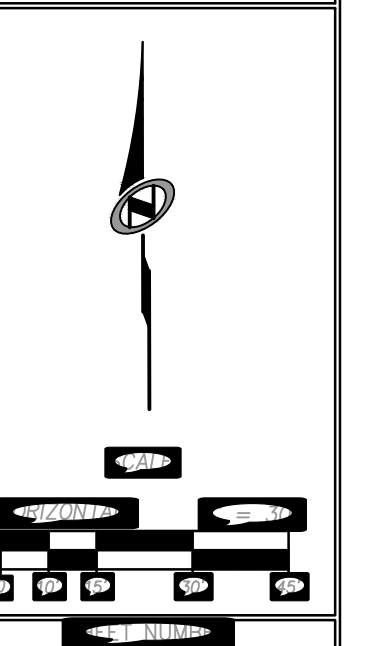
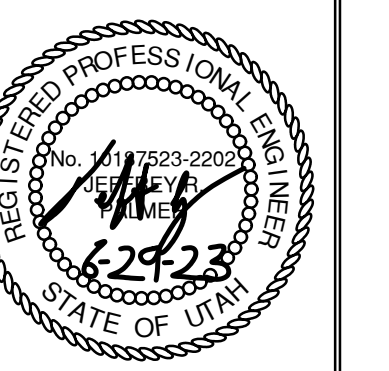

**C601**



	STABILIZATION DISTURBED AREAS WITH A TACKIFIER VIA HYDROSEEDING SEED MIXTURE. MEADOW BROME (RIGOR) 14 lb/AC RICHARD GRASS 10 lb/AC CERES (ADAK) 4 lb/AC 10% W PERPENDICULAR TO TRAIL
	GRAVEL PERCHLORATE
	PERCHLORATE
	PERCHLORATE
	PERCHLORATE
	PERCHLORATE
	PERCHLORATE
	PERCHLORATE
	PERCHLORATE
	PERCHLORATE

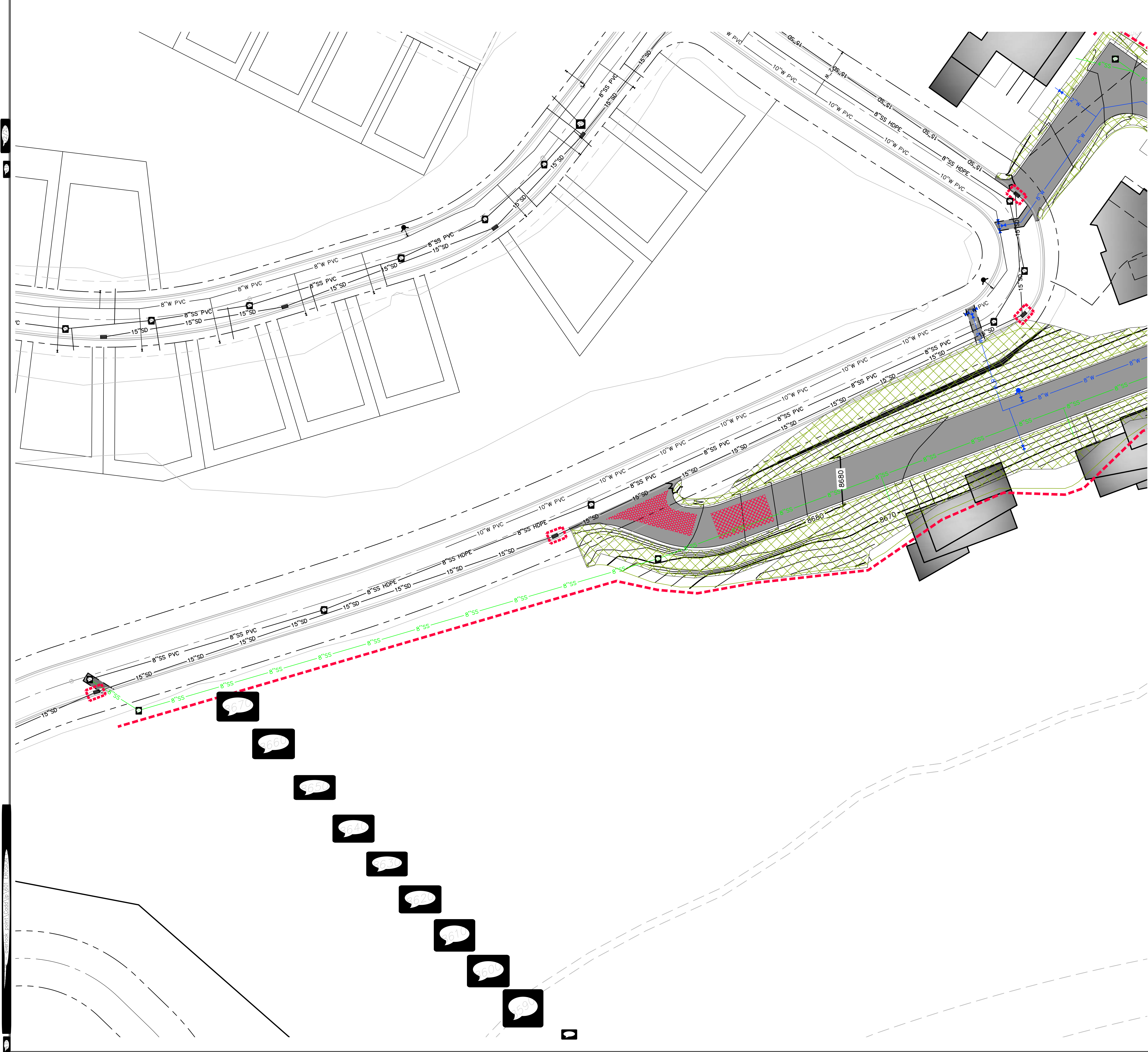



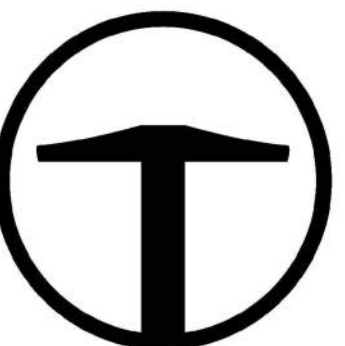

**TALISMAN**  
CIVIL CONSULTANTS  
1588 SOUTH MAIN STREET  
SUITE 200  
SALT LAKE CITY, UT 84115  
801.743.1300

**POWDER POINT  
POWDER MOUNTAIN, UTAH  
DETAILS**

DATE: 06.29.2023

TCC JOB NUMBER:



**C700**

**Catch basin**

- GENERAL**
  - The drawing shows typical pipe connections. Refer to construction drawings for connection locations or refer to field location of existing piping when engineering pipe connection to the box.
- PRODUCTS**
  - Base Course: Untreated base course, APWA Section 32 11 23. Do not use gravel as a base course without ENGINEER'S permission.
  - Backfill: Common fill, APWA Section 31 05 13. Maximum particle size 2-inches.
  - Concrete: Class 4000, APWA Section 03 30 04.
  - Reinforcement: Deformed, 60 ksi yield grade steel, ASTM A615.
- EXECUTION**
  - Base Course Placement: APWA Section 32 11 23. Maximum lift thickness is 8-inches before compaction. Compaction is 95 percent or greater relative to a modified proctor density, APWA Section 31 23 26.
  - Curb Face Opening: Make opening at least 4-inches high. Provide at least a 2-inch drop between the "warp line" in the gutter flow-line and the top of the grate at the curb face opening.
  - Concrete Placement: APWA Section 03 30 10. Provide 1/2-inch radius edges. Apply a broom finish. Apply a curing agent.
  - Backfill: Place backfill against the basin wall. Pea gravel and recycled RAP aggregate is NOT ALLOWED. Water jetting is NOT allowed. Maximum lift thickness is 8-inches before compaction. Compaction is 95 percent or greater relative to a standard proctor density, APWA Section 31 23 26.

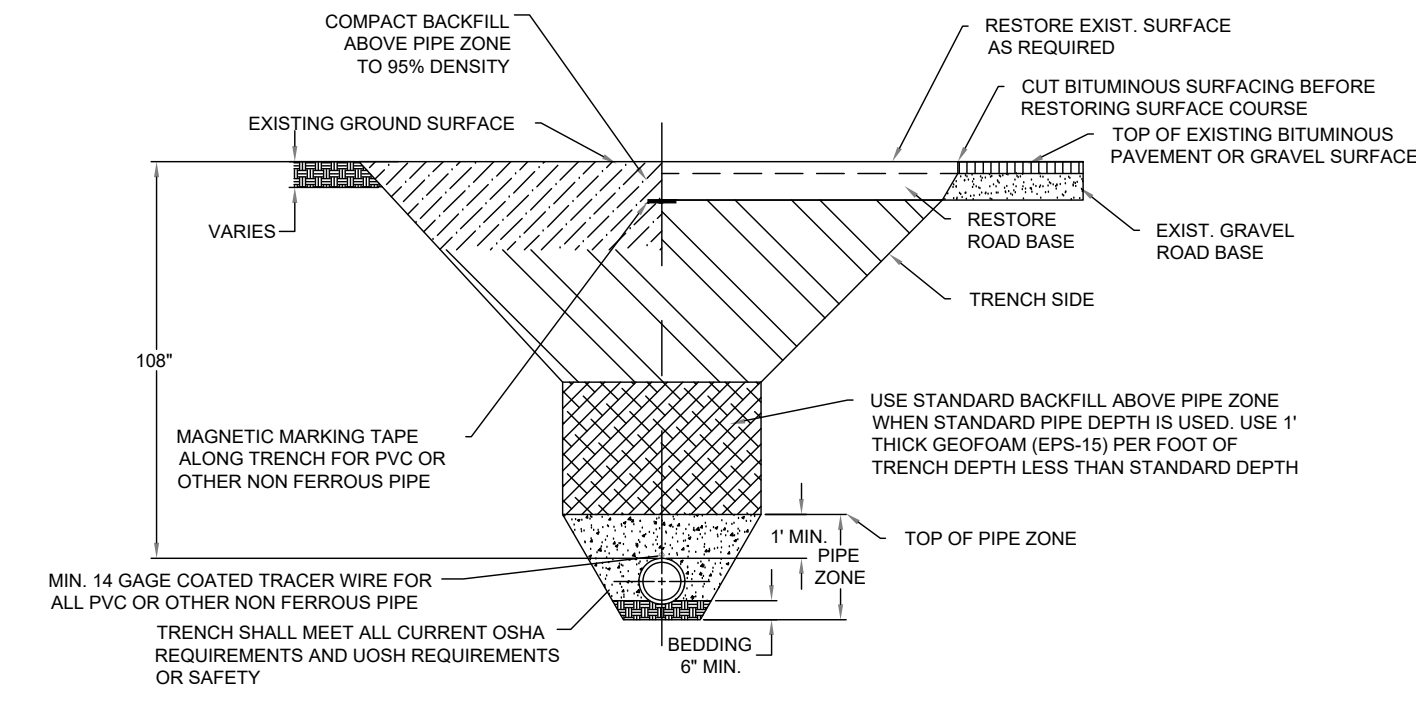

**SAFE BEARING LOADS**

SOIL TYPE	SAFE BEARING LOAD (lb/ft <sup>2</sup> )
SAND	1000
SAND & GRAVEL	1500
SAND & GRAVEL CEMENTED WITH CLAY SHALE	2000
	5000

**SAFE BEARING LOAD FORMULA**

THRUST ON FITTINGS

PIPE SIZE	TEES	90° BENDS	45° BENDS	22.5° BENDS
4"	18.5	28.1	14.2	7.2
6"	38	53.7	29.1	14.7
8"	65.8	93	50.4	25.5
10"	107.5	152	82.4	41.7
12"	153.1	216.4	117.2	59.4
14"	183.8	260.0	141.0	71.5
16"	237.8	336.3	162.8	92.7
18"	298.6	422.3	229.7	116.5

\*MULTIPLY THRUST BY MAXIMUM WATER PRESSURE

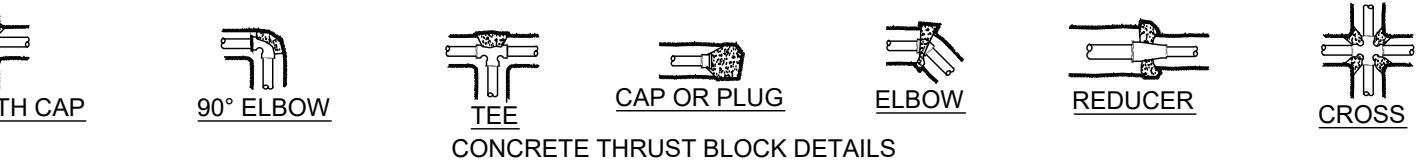

- NOTES:**
- WATER LINES 12 INCHES AND LARGER SHALL BE DUCTILE IRON CLASS-15. MAY BE DELETED WHERE DIRECTED BY DISTRICT ENGINEER.
  - WATER LINES 10 INCHES AND SMALLER SHALL BE PVC APWA C900 CLASS 200.
  - VALVES 12 INCHES AND LARGER SHALL BE BUTTERFLY VALVES.
  - WHENEVER POSSIBLE "HOT TAP" CONNECTIONS REQUIRED. HOT TAP VALVE TO BE SUPPORTED DURING CONNECTION. CONTRACTOR TO NOTIFY DISTRICT 24 HOURS IN ADVANCE OF MAKING CONNECTION.
  - PIPE ZONE SHALL BE BACKFILLED WITH 3/4" GRAVEL MATERIAL.
  - TRACING WIRE TO BE BROUGHT OUTSIDE OF BOTTOM PORTION OF VALVE BOX AND INSIDE TOP TO SURFACE.
  - FURNISH AND INSTALL POLY-WRAP ON DUCTILE IRON PIPE. POLY-WRAP MAY BE DELETED WHERE DIRECTED BY DISTRICT ENGINEER.
  - WHERE COLLAPSIBLE SOILS ARE ENCOUNTERED, FURNISH, PLACE AND COMPACT SUPPORTED BACKFILL MATERIALS AS REQUIRED AND AS DIRECTED.
  - SEE DW-2 FOR PIPE BEDDING SPECIFICATIONS
  - 9" O.D. MINIMUM COVER REQUIRED OVER PIPE. COVER REQUIREMENT MAY BE REDUCED PER RECOMMENDATION BY APPROVED GEOTECHNICAL REPORT. IN NO CASE SHALL MINIMUM COVER OVER PIPE BE LESS THAN 7'-0". GEOTECHNICAL REPORT SHALL SPECIFICALLY ADDRESS FROST DEPTH AND PIPE FREEZING POTENTIAL.

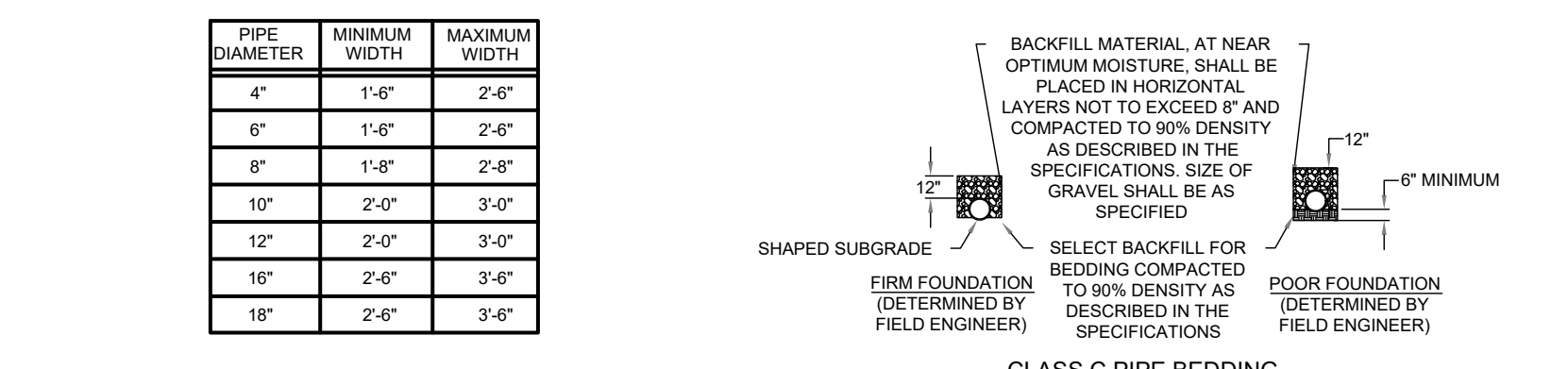
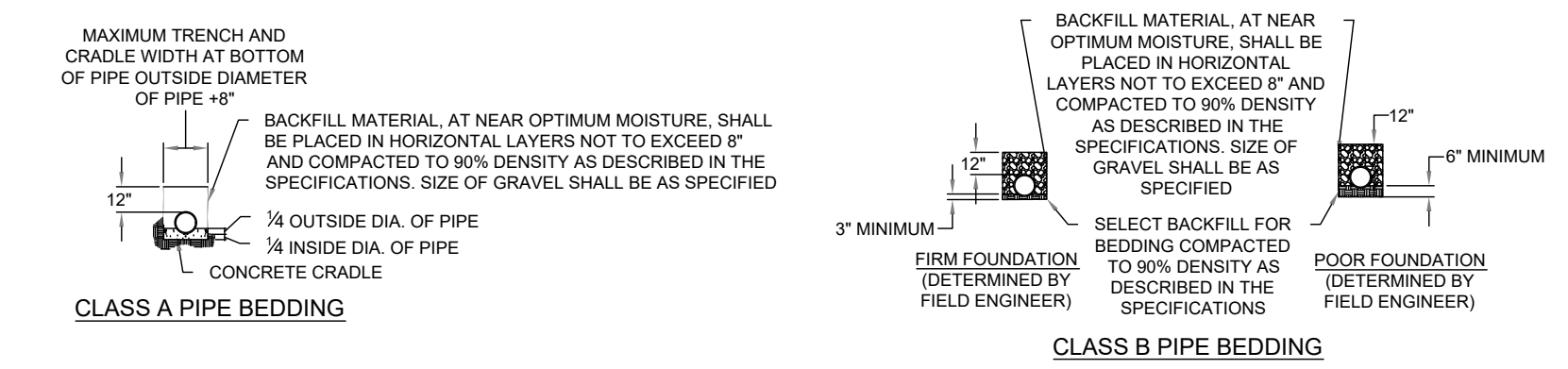
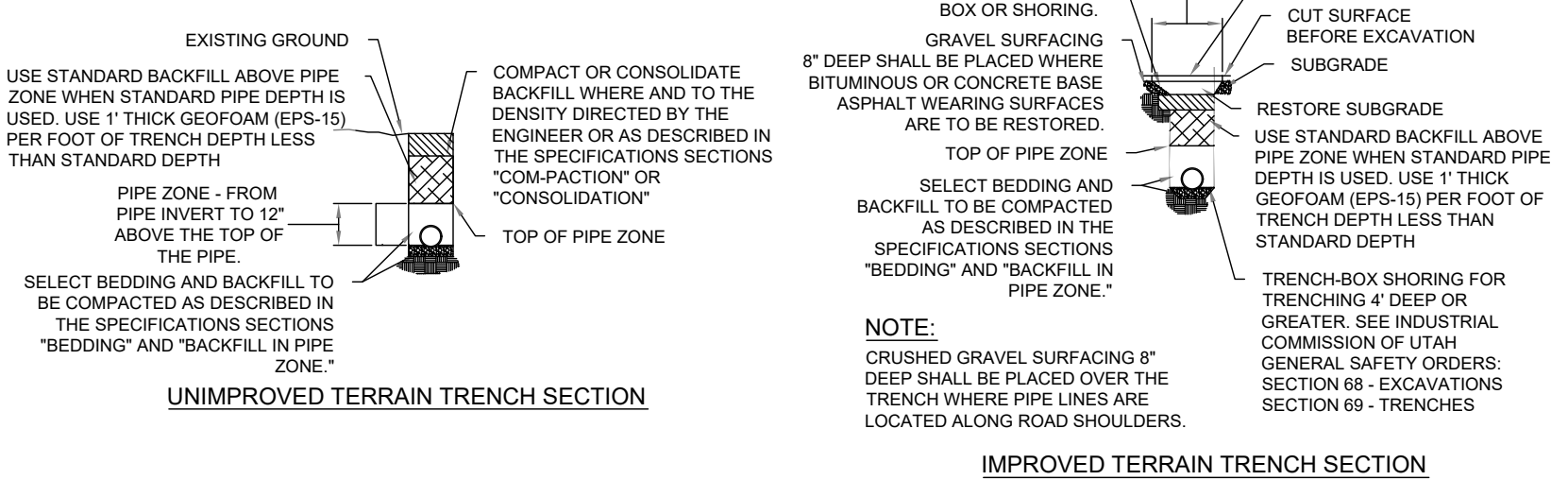

**PIPE BEDDING SPECIFICATIONS**

PIPE DIAMETER	MINIMUM WIDTH	MAXIMUM WIDTH
4"	1'-0"	2'-0"
6"	1'-0"	2'-0"
8"	1'-8"	2'-8"
10"	2'-0"	3'-0"
12"	2'-0"	3'-0"
16"	2'-6"	3'-6"
18"	2'-6"	3'-6"

**WATERLINE TRENCH DETAIL**

DATE: APRIL 2021  
DRAWING NAME: DW-1  
DRAWN BY: BRJ/M  
CHECKED/ APPROVED: [Signature]

**GILSON ENGINEERING**  
Consulting Engineers & Surveyors  
1240 SOUTH 450 EAST BLDG. C, UNIT 2, SALT LAKE, UT 84020  
PHONE: (801) 571-9414 FAX: (801) 571-9449  
WWW.PMWSOC.COM

298 24th STREET, SUITE 150, OGDEN, UT 84401  
PHONE: (801) 773-1191  
WWW.PMWSOC.COM

**315.2**

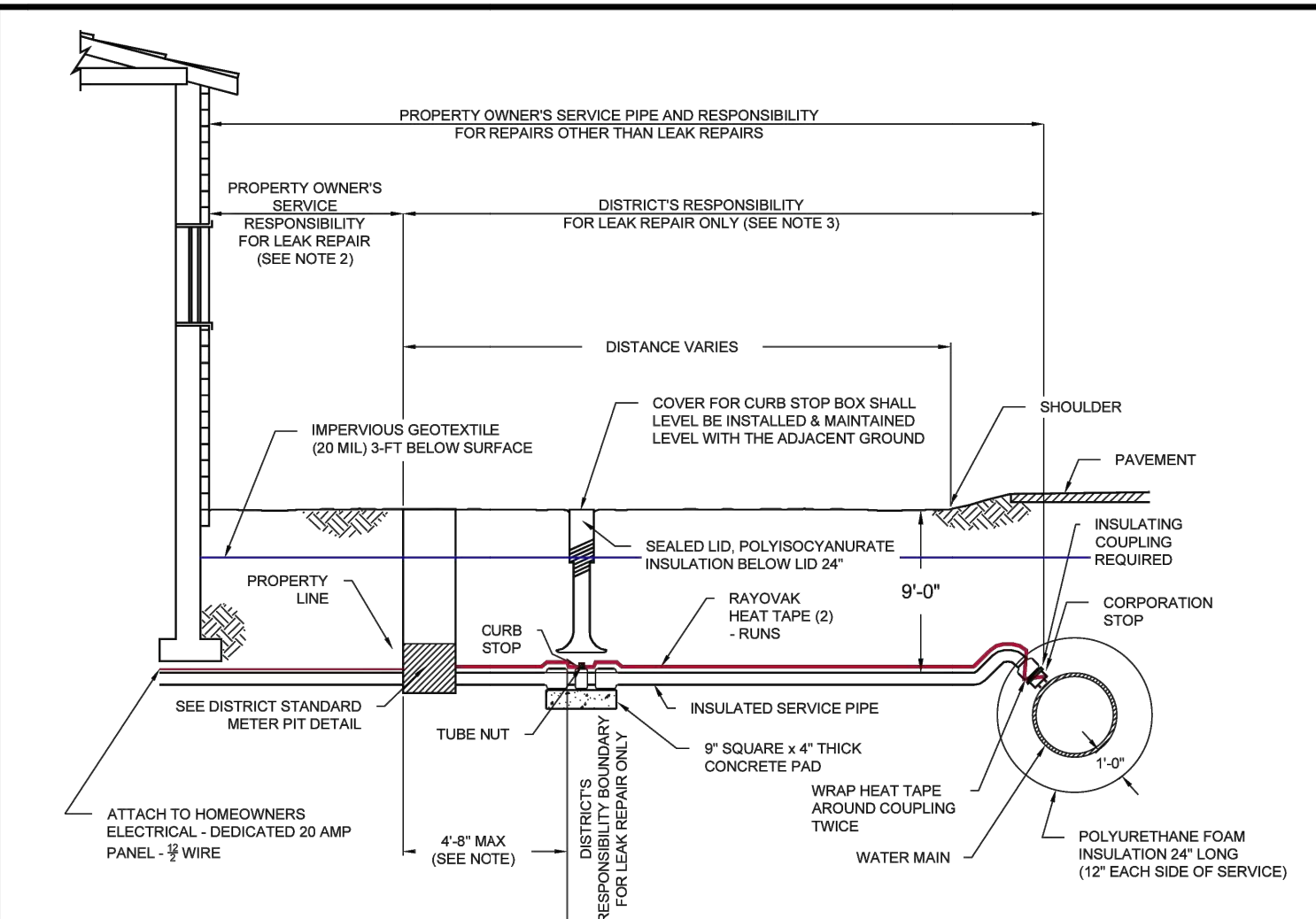

- NOTES:**
- PLACEMENT OF CURB STOP SHALL BE A MAXIMUM OF 5 FEET OUTSIDE THE PROPERTY LINE INSIDE STREET RIGHT OF WAY.
  - PROPERTY OWNER'S RESPONSIBILITY FOR LEAK REPAIR SHALL BE UP TO AND INCLUDING THE SERVICE PIPE WHICH THREADS ONTO THE WATER METER. PROPERTY OWNER'S RESPONSIBILITY FOR REPAIRS OTHER THAN LEAKS EXTENDS TO THE CORPORATION STOP.
  - DISTRICT'S RESPONSIBILITY SHALL BE THE WATER MAIN, THE CORPORATION STOP, CURB STOP, WATER METER, AND WHERE NEEDED, THE DOUBLE STRAP TAPPING SADDLE. THE DISTRICT WILL ONLY REPAIR LEAKS OCCURRING BETWEEN THE CORPORATION STOP AND THE WATER METER.
  - SEE STANDARD DETAIL WT-1 AND WT-2 FOR WATER TRENCH REQUIREMENTS
  - NO LATERAL ARE TO BE INSTALLED WITHIN 5' OF BEDROCK
  - 12" THICK CLAY CUTOFF AT EACH END OF WATER SERVICE INSULATION FROM IMPERVIOUS GEOTEXTILE TO BOTTOM OF TRENCH
  - INSULATED SERVICE PIPE: SERVICE LINE ENCASED IN 8" SEAMLESS HDPE WITH CLOSED-CELL CROSS - LINKED POLYETHYLENE FOAM AND HEAT TAPE
  - 9'-0" MINIMUM COVER REQUIRED OVER PIPE. COVER REQUIREMENT MAY BE REDUCED PER RECOMMENDATION BY APPROVED GEOTECHNICAL REPORT. IN NO CASE SHALL MINIMUM COVER OVER PIPE BE LESS THAN 7'-0". GEOTECHNICAL REPORT SHALL SPECIFICALLY ADDRESS FROST DEPTH AND PIPE FREEZING POTENTIAL.

**TYPICAL SMALL DIAMETER WATER SERVICE LINE DETAIL**

DATE: APRIL 2021  
DRAWING NAME: DW-5  
DRAWN BY: BRJ/M  
CHECKED/ APPROVED: [Signature]

**GILSON ENGINEERING**  
Consulting Engineers & Surveyors  
1240 SOUTH 450 EAST BLDG. C, UNIT 2, SALT LAKE, UT 84020  
PHONE: (801) 571-9414 FAX: (801) 571-9449  
WWW.PMWSOC.COM

**POWDER MOUNTAIN WATER AND SEWER IMPROVEMENT DISTRICT**  
298 24th STREET, SUITE 150, OGDEN, UT 84401  
PHONE: (801) 773-1191  
WWW.PMWSOC.COM

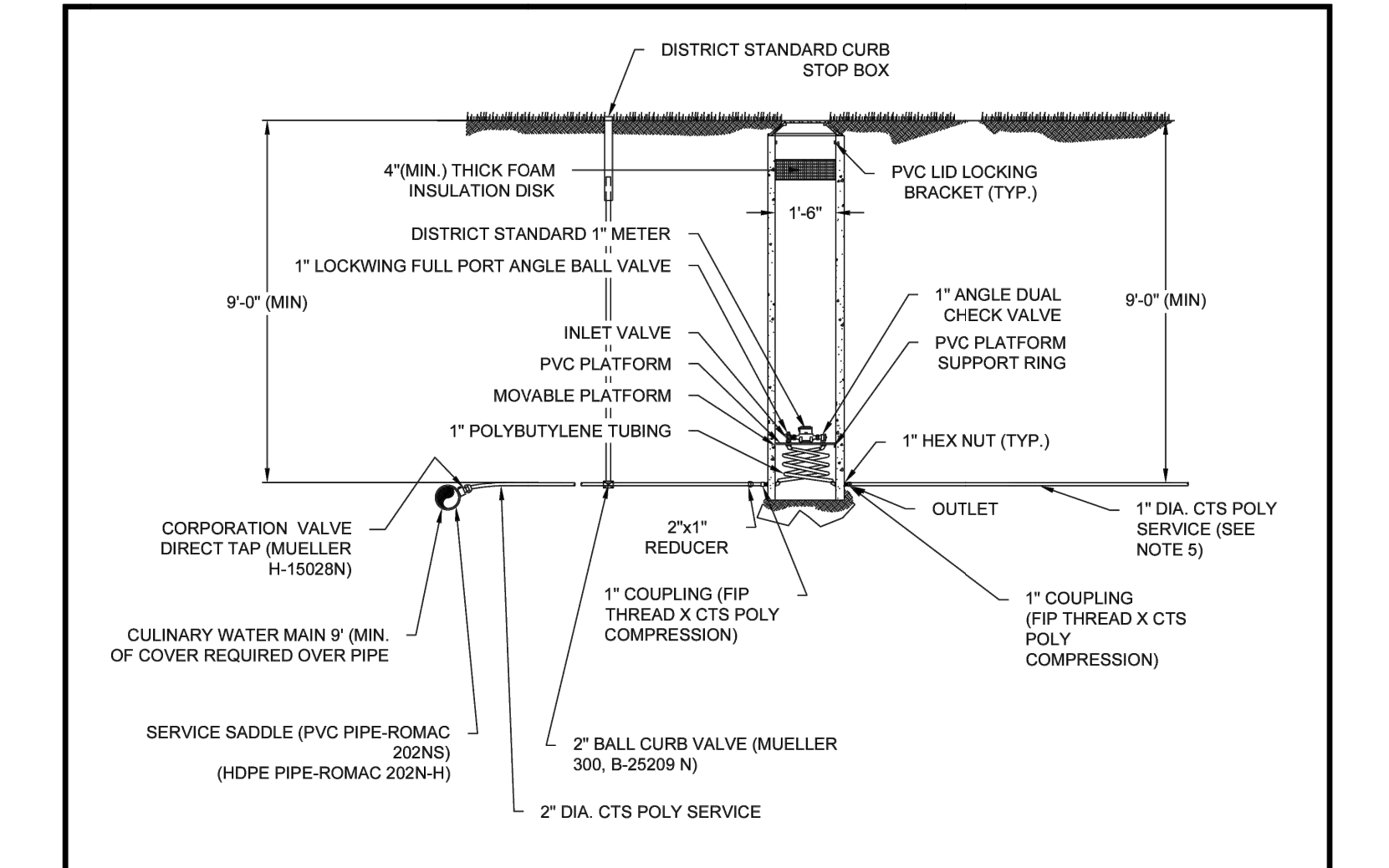

- NOTES:**
- METER BOXES SHALL BE 18" DIA. BY 96" DEEP MUELLER-THERMAL-COIL PVC BOXES FOR 1" SINGLE METERS (MUELLER 330CS1896FBBSN)
  - POLYETHYLENE PIPE FOR WATER SERVICES SHALL BE PE 3408 TUBING, SDR-8, COPPER TUBING SIZE AND NSF APPROVED FOR POTABLE WATER
  - METER SHALL BE INSTALLED IN HORIZONTAL ALIGNMENT, WITH METER FACING UP, ONLY.
  - ALL PIPE, FITTING, AND VALVES SHALL COMPLY WITH NSF STANDARD NO. 14 FOR USE WITH POTABLE WATER.
  - THE CUSTOMER IS RESPONSIBLE FOR PROPERLY SIZING THE SERVICE TO DELIVER FLOWS REQUIRED FOR FIRE SPRINKLER SYSTEMS. THE SERVICE FROM THE METER TO THE BUILDING CAN BE UP-SIZED FROM 1" DIAMETER IF NECESSARY. CONNECTING FIRE SPRINKLER LINES TO THE 2" SERVICE BEFORE THE METER MAY BE APPROVED BY THE DISTRICT ENGINEER ONLY IF THE REQUIRED FIRE SPRINKLER CANNOT BE DELIVERED THROUGH THE METER.
  - THE DEVELOPER IS RESPONSIBLE FOR INSTALLATION OF THE SERVICE FROM THE MAIN TO THE METER BOX, INCLUDING THE SERVICE SADDLE, CORP STOP, CURB STOP BOX, AND METER BOX.
  - BASED UPON OBSERVATIONS DURING WINTER CONDITIONS, THE DISTRICT HAS DETERMINED THAT 9" (MIN) OF COVER OVER WATER MAINS AND SERVICES IS REQUIRED TO PROTECT AGAINST FREEZING.

**TYPICAL METER PIT DETAIL**

DATE: APRIL 2021  
DRAWING NAME: DW-7  
DRAWN BY: BRJ/M  
CHECKED/ APPROVED: [Signature]

**GILSON ENGINEERING**  
Consulting Engineers & Surveyors  
1240 SOUTH 450 EAST BLDG. C, UNIT 2, SALT LAKE, UT 84020  
PHONE: (801) 571-9414 FAX: (801) 571-9449  
WWW.PMWSOC.COM

**POWDER MOUNTAIN WATER AND SEWER IMPROVEMENT DISTRICT**  
298 24th STREET, SUITE 150, OGDEN, UT 84401  
PHONE: (801) 773-1191  
WWW.PMWSOC.COM

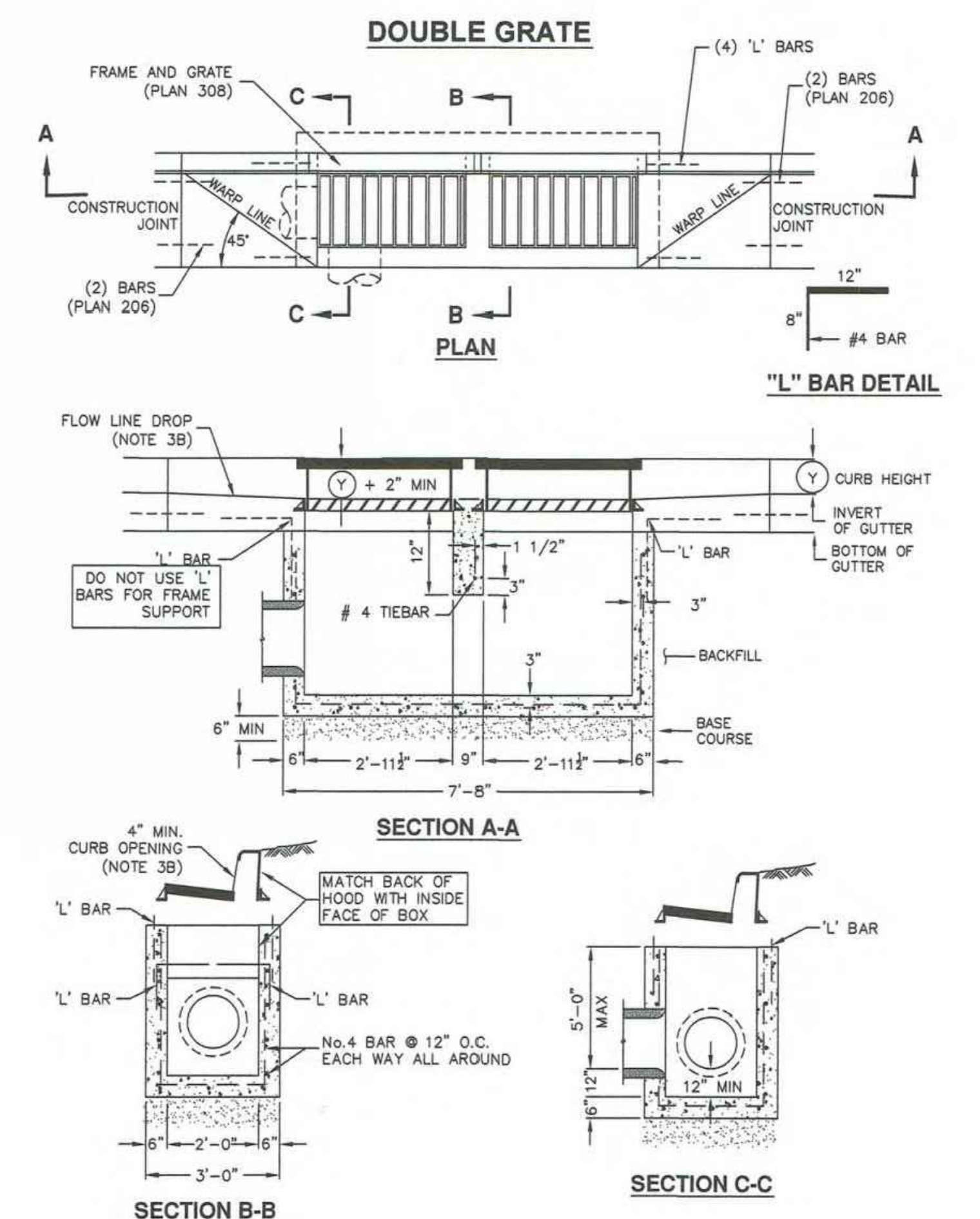

**Catch basin**

Plan **315.2**  
September 2010

**APWA**  
Utah Chapter

**811**  
CALL BEFORE YOU DIG  
SAFE DIGGING PRACTICE



**Trench backfill**

1. **GENERAL**  
A. The drawing applies to backfilling a trench (and embankment) above the pipe zone.
2. **PRODUCTS**  
A. Backfill: Common fill, APWA Section 31 05 13. Maximum particle size 3-inches.  
B. Flowable Fill: APWA Section 31 05 15. Target is 60 psi in 28 days with 90 psi maximum in 28 days. It must flow easily requiring no vibration for consolidation.
3. **EXECUTION**  
A. Trench Backfill Above the Pipe Zone: Follow requirement indicated in APWA Section 33 05 20 and the following provisions. See Standard Plan 382 for backfilling the pipe zone.  
1) DO NOT USE sewer rock, pea gravel, or recycled RAP aggregate as trench backfill.  
2) Maximum lift thickness is 8-inches before compaction. Compaction is 95 percent or greater relative to a standard proctor density, APWA Section 31 23 26.  
3) Water jetting is NOT allowed.  
B. Flowable Fill: If controlled low strength material is placed in the trench. Cure the material before placing surface restorations.  
C. Embankment Backfill: When trench sides are sloped proceed as follows.  
1) Maximum lift thickness is 8-inches before compaction.  
2) Compact per APWA Section 31 23 26 to 95 percent or greater relative to a standard proctor density.  
3) Submission of quality control compaction test result data may be requested by ENGINEER at any time. Provide results of tests immediately upon request.  
D. Surface Restoration:  
1) Landscaped Surface: Follow APWA Section 32 92 00 (turf or grass) or APWA Section 32 93 13 (ground cover) requirements. Rake to match existing grade. Replace vegetation to match pre-construction conditions.  
2) Paved Surface: Follow APWA Section 33 05 25 (bituminous pavement surfacing), or APWA Section 33 05 25 (concrete pavement surfacing). Do not install surfacing until compaction density is acceptable to ENGINEER.

**Pipe zone backfill**

1. **GENERAL**  
A. Install the pipe in the center of the trench or no closer than 6-inches from the wall of the pipe to the wall of the trench.
2. **PRODUCTS**  
A. Base Course: Untreated base course, APWA Section 32 11 23. Do not use gravel as a base course without ENGINEER's permission.  
B. Backfill: Common fill, APWA Section 31 05 13. Maximum particle size 2-inches.  
C. Concrete: APWA Section 03 30 04.  
D. Flowable Fill: Target is 60 psi in 28 days with 90 psi maximum in 28 days, APWA Section 31 05 15. It must flow easily requiring no vibration for consolidation.  
E. Stabilization-Separation Geotextile: Moderate or high at CONTRACTOR's choice, APWA Section 31 05 19.
3. **EXECUTION**  
A. Excavate the Pipe Zone: Width is measured at the pipe spring line and includes any necessary sheathing. Provide width recommended by pipe manufacturer. Follow manufacturer's recommendations when using trench boxes.  
B. Foundation Stabilization: Get ENGINEER's permission before installing common fill. Vibrate to stabilize. Installation of stabilization-separation geotextile will be required to separate backfill material and native subgrade materials if common fill cannot provide a working surface or prevent soils migration.  
C. Bedding: Follow APWA Section 33 05 20 requirements and the following provisions.  
1) Furnish untreated base course material unless specified otherwise by pipe manufacturer.  
2) Maximum lift thickness is 8-inches.  
3) Bedding immediately under the pipe should not be compacted, but loosely placed.  
4) Compaction is 95 percent or greater relative to a modified proctor density, APWA Section 31 23 26.  
5) When using concrete, provide at least Class 2,000, APWA Section 03 30 04.  
D. Pipe Zone: DO NOT USE sewer rock, pea gravel, or recycled RAP aggregate in the pipe zone. Water jetting is NOT allowed.  
1) Maximum lift thickness is 8-inches before compaction. Compaction is 95 percent or greater relative to a modified proctor density, APWA Section 31 23 26 unless pipe manufacturer requires more stringent installation.  
2) Submission of quality control compaction test result data developed for the haunch zone may be requested by ENGINEER at any time. CONTRACTOR is to provide results of tests immediately upon request.  
E. Flowable Fill (when required and if allowed by pipe manufacturer):  
1) Place the controlled low strength material, APWA Section 31 05 15.  
2) Prevent pipe flotation by installing in lifts and providing pipe restraints as required by pipe manufacturer.  
3) Reset pipe to line and grade if pipe "floats" out of position.

**Pipe outfall**

1. **GENERAL**  
A. Round concrete pipe application.  
B. Additional requirements are specified in APWA Section 33 05 02.
2. **PRODUCTS**  
A. Use the same quality of precast end section as the pipe.  
B. Use the joint material and connection that is the same as the joints in the pipeline.
3. **EXECUTION**  
A. General dimensions and geometric shapes may vary from manufacturer to manufacturer.  
B. Steel reinforcement is not required in the concrete end section shown.  
C. Provide joint restraint connectors if required by ENGINEER.

381

NARRATIVE: THIS PLAN SHOWS VARIOUS SLOPES RECOMMENDED FOR VARIOUS TYPES OF SLOPE STABILITY PROBLEMS. THE VERTICAL TEXT INDICATES VARIOUS MATERIALS THAT MAY BE ENCOUNTERED. THE SERVICES OF A PROFESSIONAL SOILS ENGINEER SHOULD BE USED TO VERIFY SLOPE STABILITY.

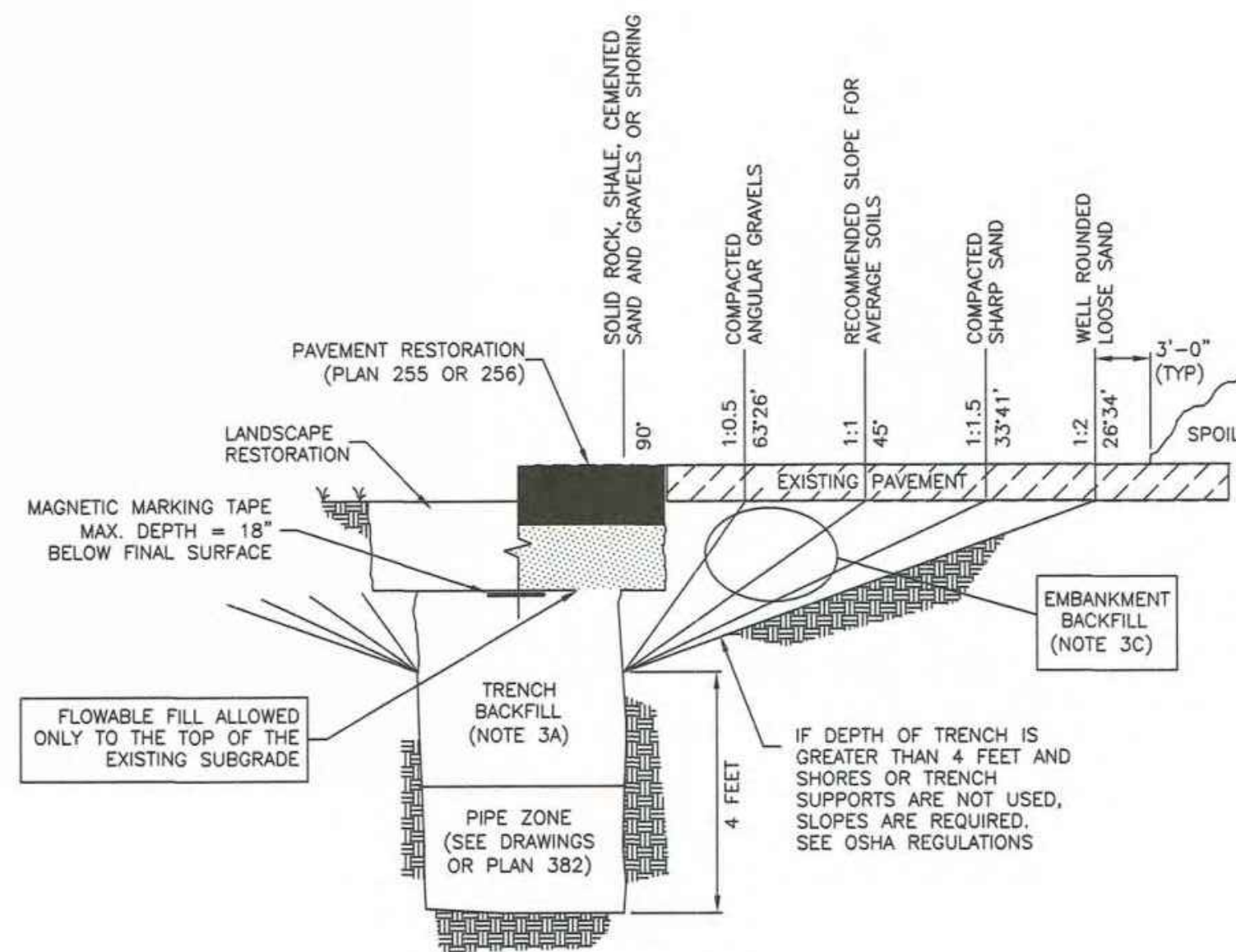

Plan 381  
July 2016



Trench backfill

382

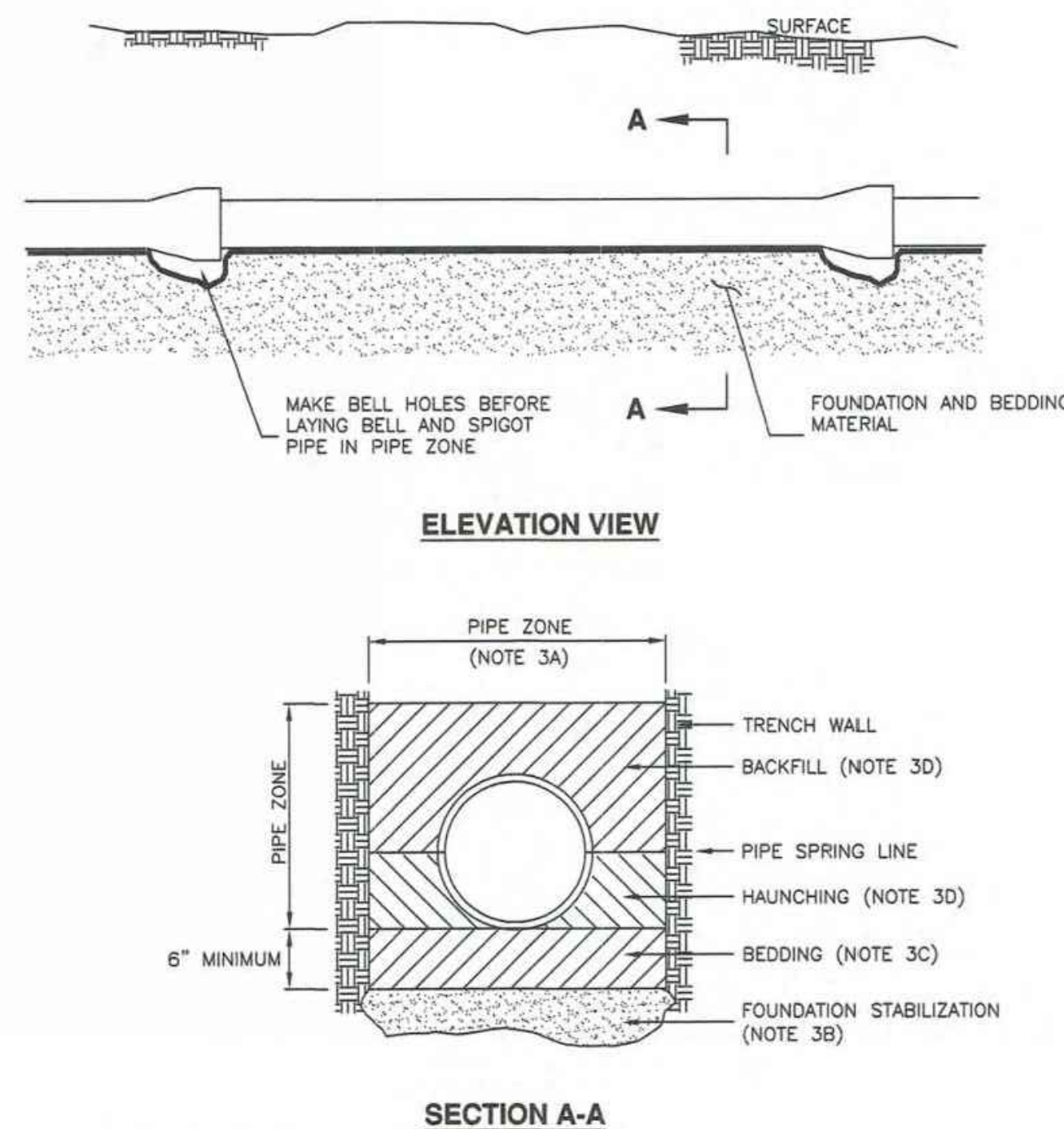

**INSTALLATION**

CONCRETE PIPE: FOLLOW ASTM C 1479  
\*STANDARD PRACTICE FOR INSTALLATION OF PRECAST CONCRETE SEWER, STORM DRAIN, AND CULVERT PIPE USING STANDARD INSTALLATIONS.  
PLASTIC PIPE: FOLLOW ASTM D 2321  
\*STANDARD PRACTICE FOR UNDERGROUND INSTALLATION OF THERMOPLASTIC PIPE FOR SEWERS AND OTHER GRAVITY-FLOW APPLICATIONS\*  
CORRUGATED METAL PIPE: FOLLOW ASTM A 798  
\*STANDARD PRACTICE FOR INSTALLING FACTORY-MADE CORRUGATED STEEL PIPE FOR SEWERS AND OTHER APPLICATIONS.  
VITRIFIED CLAY PIPE: FOLLOW ASTM C 12.  
\*STANDARD RECOMMENDED PRACTICE FOR INSTALLING VITRIFIED CLAY PIPE LINES.

Plan 382  
January 2011



Pipe zone backfill

323.1

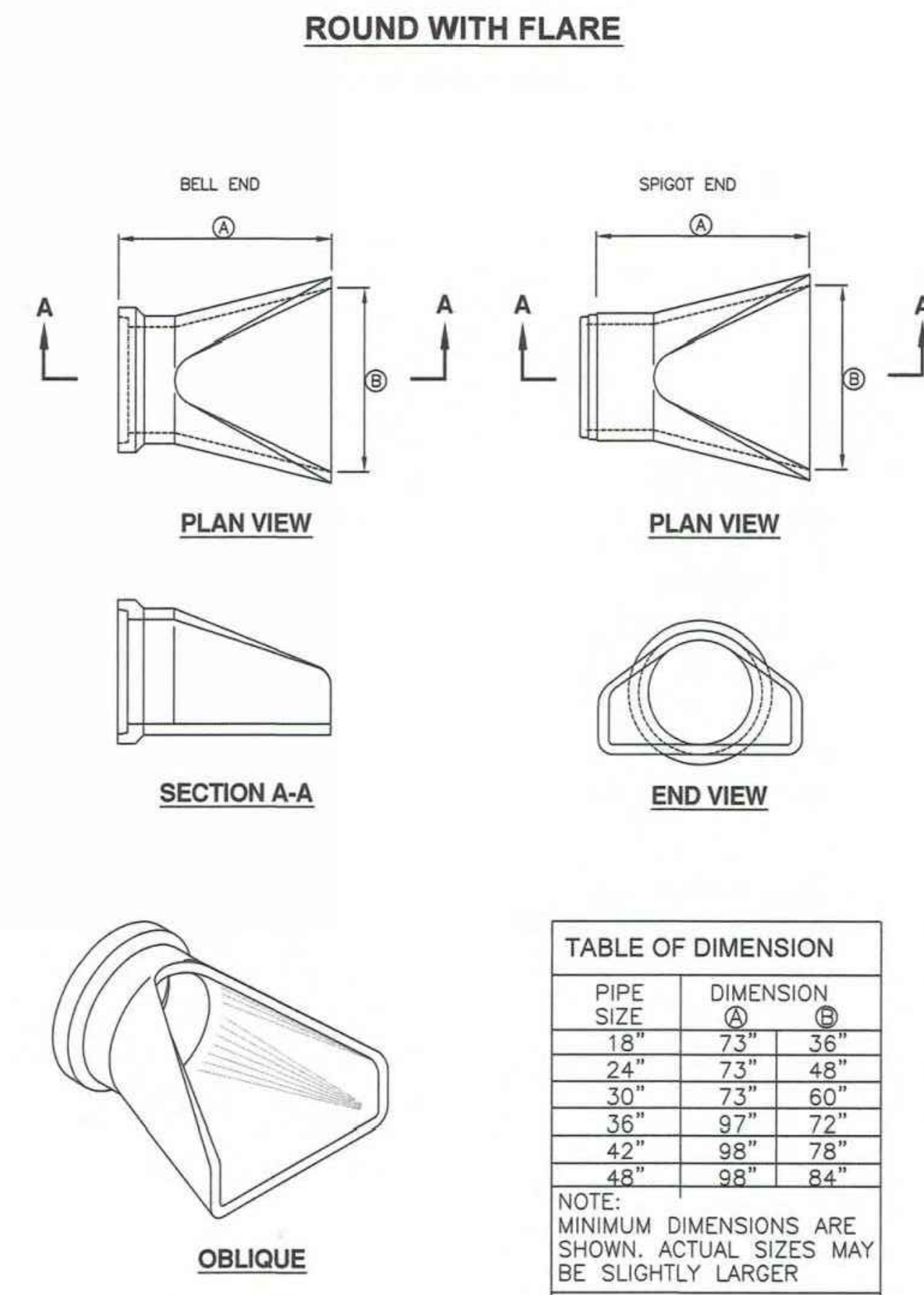

Plan 323.1  
November 2010



Pipe outfall

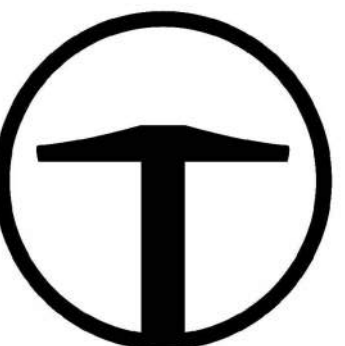

TALISMAN CIVIL CONSULTANTS  
1588 SOUTH MAIN STREET  
SUITE 200  
SALT LAKE CITY, UT 84115  
801.743.1300

POWDER POINT  
POWDER MOUNTAIN, UTAH  
DETAILS

DATE: 06.29.2023

TCC JOB NUMBER: 22-126



C701



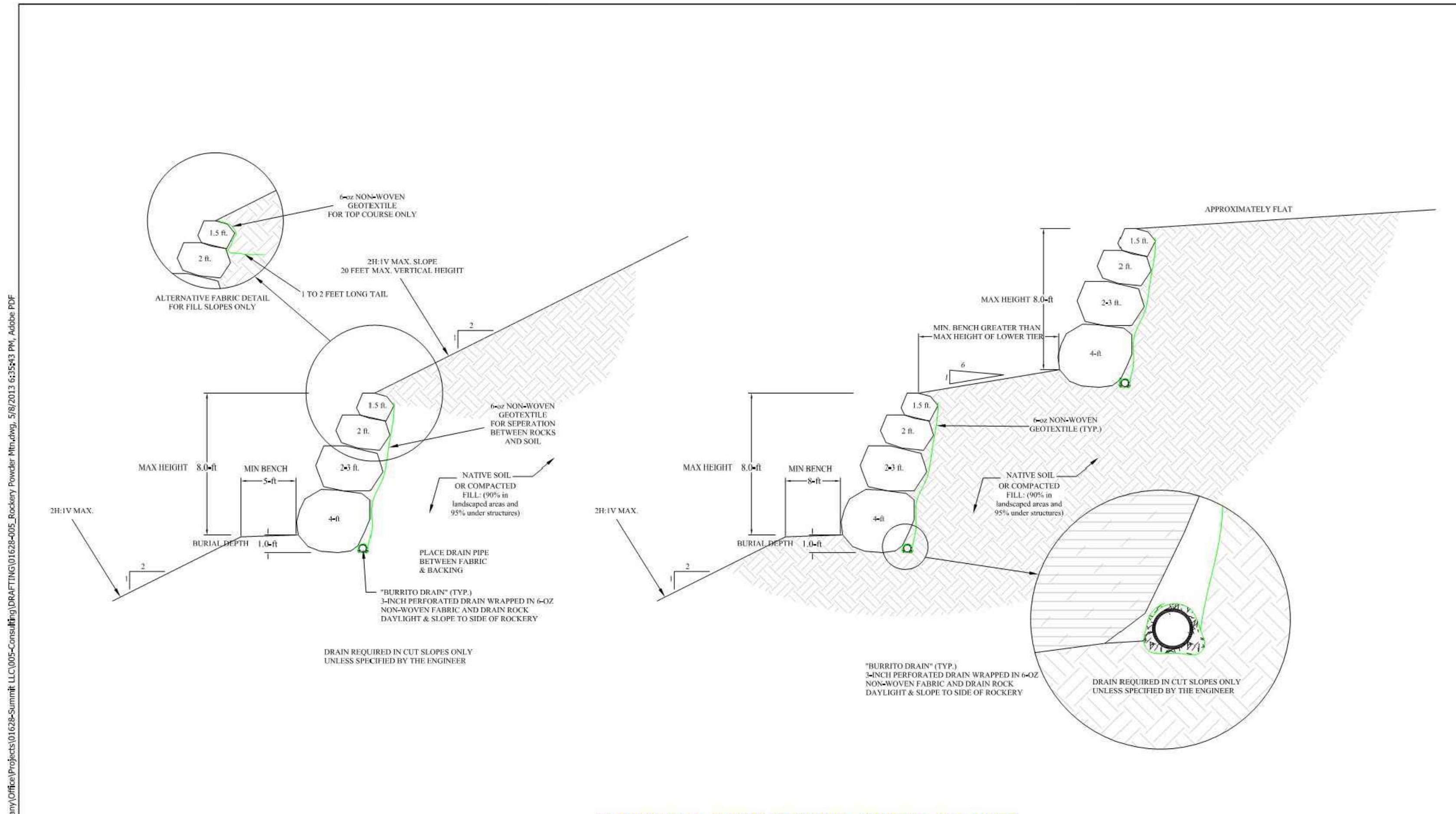

**CONCEPTUAL CROSS-SECTION - TYPICAL ROCKERY**  
APPROXIMATE GRAPHICAL SCALE: 1 INCH = 5 FEET (1:1X17 ONLY)

MARK	REVISIONS	DATE	BY	CHK

**IGES**  
12429 SOUTH 300 EAST, STE. 100  
DRAPER, UTAH 84020  
(801) 748-4044 FAX: (801) 748-4045

**ROCKERY CONSTRUCTION GUIDELINES**  
POWDER MOUNTAIN RESORT  
WEBER COUNTY, UTAH  
CONCEPTUAL SECTION VIEW

DESIGNED BY: DAG MAY 07, 2013 PLOT SCALE: 1=1  
DRAWN BY: DAG MAY 07, 2013 DWG SCALE: 1"=5'  
CHECKED BY: KAH MAY 08, 2013 SHEET NO. A-1  
APPROVED BY: DAG MAY 07, 2013 REV: N/A  
IGES PROJECT NO. 01628-005

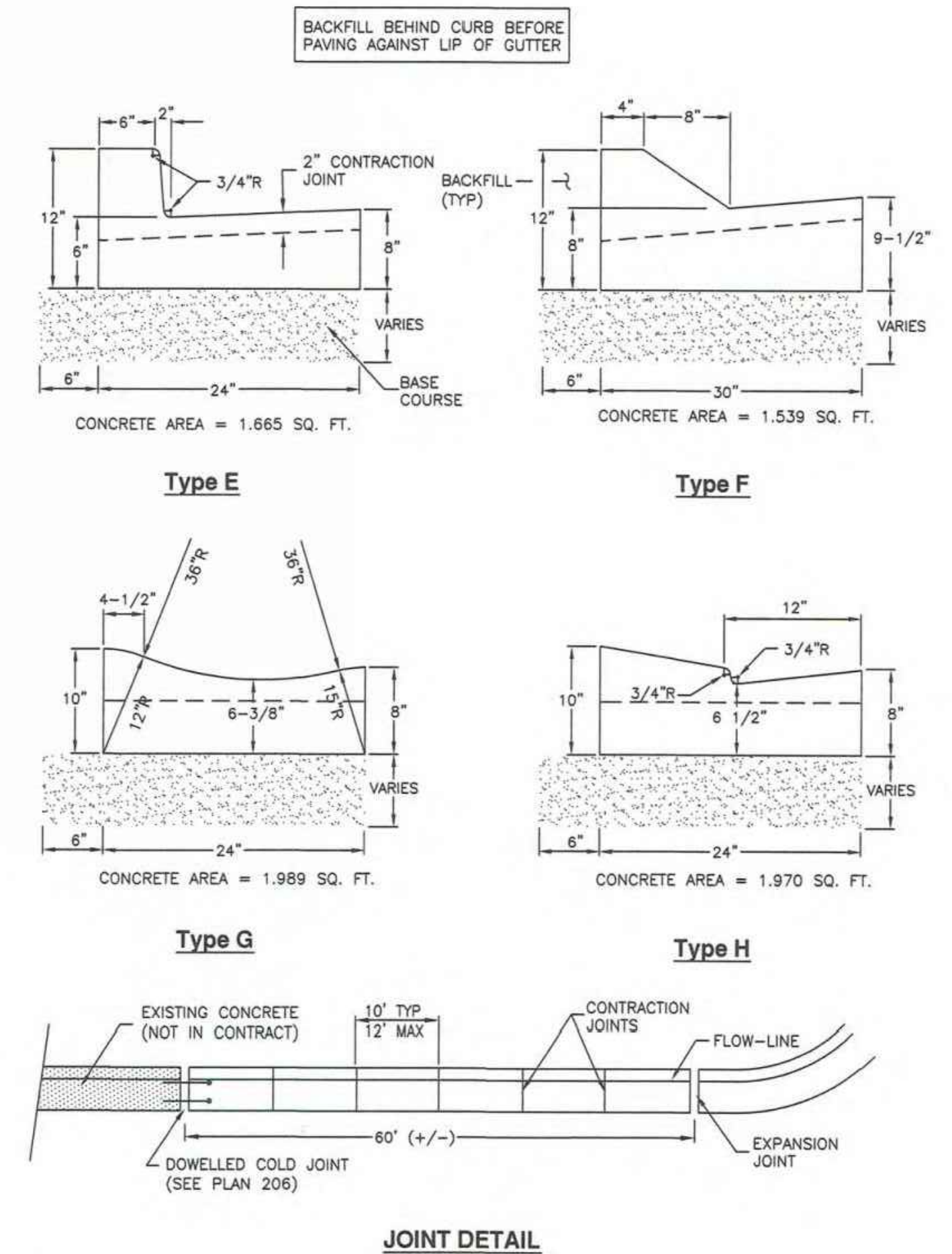

**JOINT DETAIL**  
Curb and gutter

Plan 205.2  
April 2011



Curb and gutter

- GENERAL**
  - A. Variance from specified dimensions and slopes must be acceptable to the ENGINEER. System configuration may be changed at ENGINEER'S discretion.
  - B. Additional requirements are specified in APWA Section 32 16 13.
- PRODUCTS**
  - A. Base Course: Untreated base course, APWA Section 32 11 23. Do not use gravel as a base course without ENGINEER'S permission.
  - B. Expansion Joint Filler: 1/2-inch thick type F1 full depth, APWA Section 32 13 73.
  - C. Concrete: Class 4000, APWA Section 03 30 04. If necessary, provide concrete that achieves design strength in less than 7 days. Use caution; however, as concrete crazing (spider cracks) may develop if air temperature exceeds 90 degrees F.
  - D. Concrete Curing Agent: Clear membrane forming compound with fugitive dye (Type ID Class A), APWA Section 03 39 00.
- EXECUTION**
  - A. Base Course Placement: APWA Section 32 05 10. Thickness is 6-inches if flow-line grade is 0.5 percent (s=0.005) or greater. If slope is less, provide 8-inches. Maximum lift thickness before compaction is 8-inches when using riding equipment or 6-inches when using hand held equipment. Compaction is 95 percent or greater relative to a modified proctor density, APWA Section 31 23 26.
  - B. Concrete Placement: APWA Section 03 30 10.
    - 1) Install expansion joints vertical, full depth, with top of filler set flush with concrete surface. Install at the start or end of a street intersection curb return. Expansion joints are not required in concrete placement using slip-form construction.
    - 2) Install contraction joints vertical, 1/8-inch wide or 1/4 slab thickness if the slab is greater than 8-inches thick. Match joint location in adjacent Portland-cement concrete roadway pavement.
    - 3) Provide 1/2-inch radius edges. Apply a broom finish. Apply a curing agent.
  - C. Protection and Repair: Protect concrete from deicing chemicals during cure. Repair construction that does not drain. If necessary, fill flow-line with water to verify.

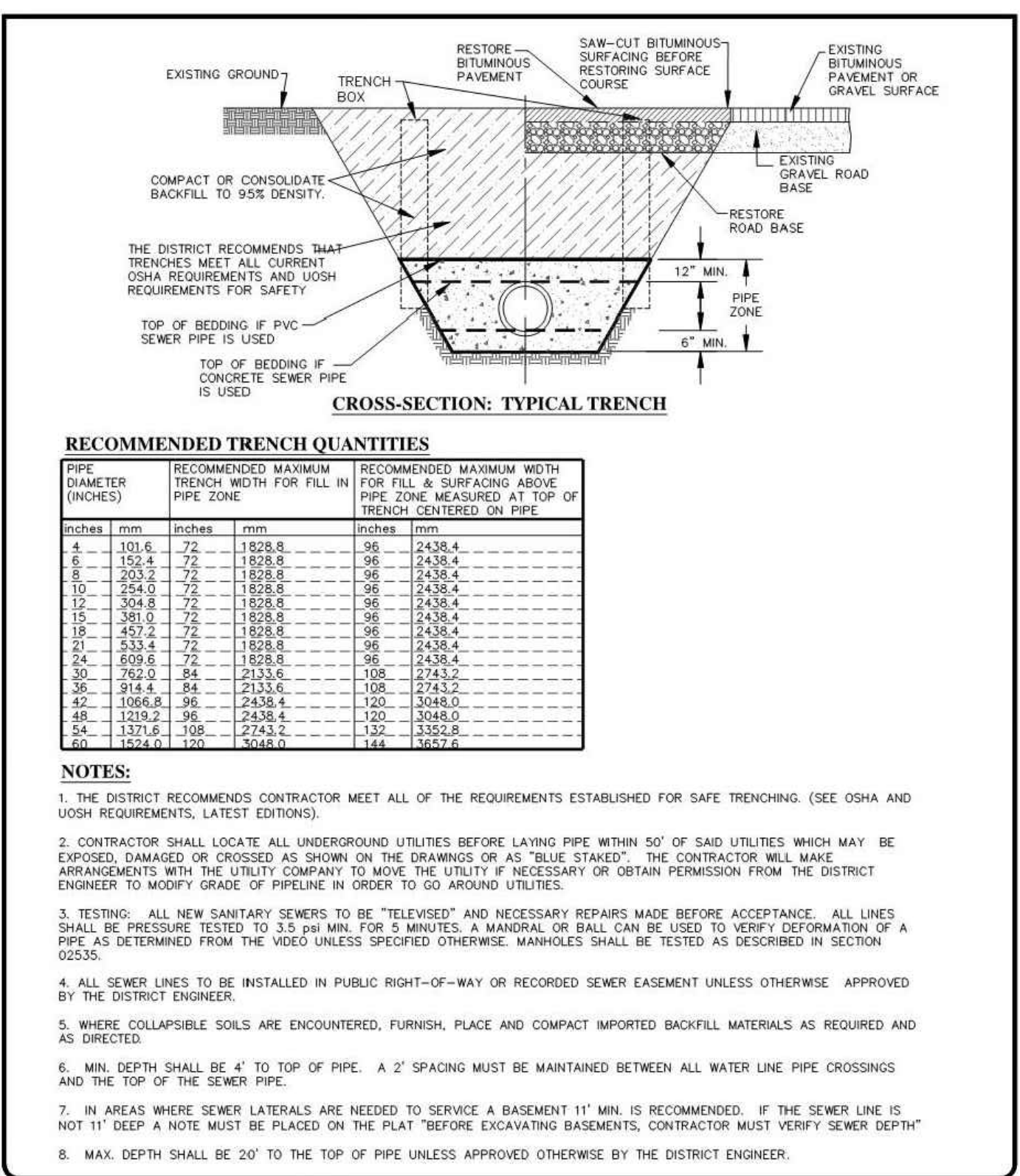

**CROSS-SECTION: TYPICAL TRENCH**

**RECOMMENDED TRENCH QUANTITIES**

PIPE DIAMETER (INCHES)	RECOMMENDED MAXIMUM TRENCH WIDTH FOR FILL IN PIPE ZONE	RECOMMENDED MAXIMUM WIDTH FOR FILL & SURFACING ABOVE PIPE ZONE MEASURED AT TOP OF TRENCH CENTERED ON PIPE
4	120.0	152.0
6	155.4	187.8
8	203.2	235.6
10	244.0	276.4
12	304.8	337.2
15	381.0	413.4
18	457.2	489.6
21	533.4	565.8
24	609.6	642.0
30	762.0	794.4
36	914.4	946.8
42	1066.8	1099.2
48	1219.2	1251.6
54	1371.6	1404.0
60	1524.0	1556.4

- NOTES:**
- THE DISTRICT RECOMMENDS CONTRACTOR MEET ALL OF THE REQUIREMENTS ESTABLISHED FOR SAFE TRENCHING (SEE OSHA AND USOH REQUIREMENTS, LATEST EDITIONS).
  - CONTRACTOR SHALL LOCATE ALL UNDERGROUND UTILITIES BEFORE LAYING PIPE WITHIN 50' OF SAID UTILITIES WHICH MAY BE EXPOSED, DAMAGED OR CROSSED AS SHOWN ON THE DRAWINGS OR AS "BLUE STAKED". THE CONTRACTOR WILL MAKE ARRANGEMENTS WITH THE UTILITY COMPANY TO MOVE THE UTILITY IF NECESSARY OR OBTAIN PERMISSION FROM THE DISTRICT ENGINEER TO MODIFY GRADE OF PIPELINE IN ORDER TO GO AROUND UTILITIES.
  - TESTING: ALL NEW SANITARY SEWERS TO BE "TELETESTED" AND NECESSARY REPAIRS MADE BEFORE ACCEPTANCE. ALL LINES SHALL BE PRESSURE TESTED TO 3.5 PSI MIN. FOR 5 MINUTES. A MANHOLE OR DIAL CAN BE USED TO VERIFY DEFORMATION OF A PIPE AS DETERMINED FROM THE VIDEO UNLESS SPECIFIED OTHERWISE. MANHOLES SHALL BE TESTED AS DESCRIBED IN SECTION 02535.
  - ALL SEWER LINES TO BE INSTALLED IN PUBLIC RIGHT-OF-WAY OR RECORDED SEWER EASEMENT UNLESS OTHERWISE APPROVED BY THE DISTRICT ENGINEER.
  - WHERE COLLAPSIBLE SOILS ARE ENCOUNTERED, FURNISH PLACE AND COMPACT IMPORTED BACKFILL MATERIALS AS REQUIRED AND AS DIRECTED.
  - MIN. DEPTH SHALL BE 4' TO TOP OF PIPE. A 2' SPACING MUST BE MAINTAINED BETWEEN ALL WATER LINE PIPE CROSSINGS AND THE TOP OF THE SEWER PIPE.
  - IN AREAS WHERE SEWER LATERALS ARE NEEDED TO SERVE A BASEMENT 1' MIN. IS RECOMMENDED. IF THE SEWER LINE IS NOT 1' DEEP A NOTE MUST BE PLACED ON THE PLAN "BEFORE EXCAVATING BASEMENTS, CONTRACTOR MUST VERIFY SEWER DEPTH"
  - MAX. DEPTH SHALL BE 20' TO THE TOP OF PIPE UNLESS APPROVED OTHERWISE BY THE DISTRICT ENGINEER.

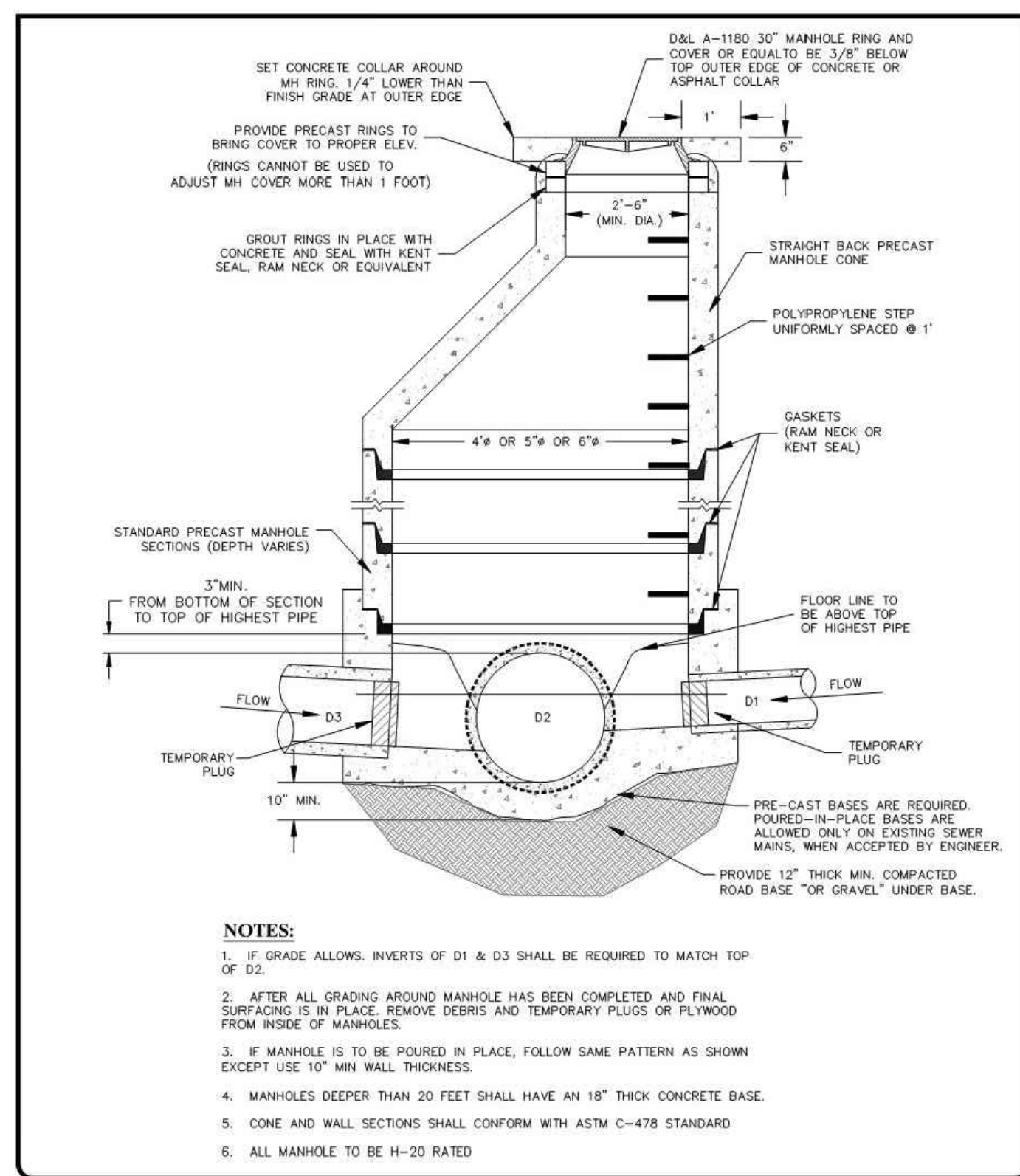

- NOTES:**
- IF GRADE ALLOWS, INVERTS OF D1 & D3 SHALL BE REQUIRED TO MATCH TOP OF D2.
  - AFTER ALL GRADING AROUND MANHOLE HAS BEEN COMPLETED AND FINAL SURFACING IS IN PLACE, REMOVE DEBRIS AND TEMPORARY PLUGS OR PLYWOOD FROM INSIDE OF MANHOLES.
  - IF MANHOLE IS TO BE POURED IN PLACE, FOLLOW SAME PATTERN AS SHOWN EXCEPT USE 10" MIN WALL THICKNESS.
  - MANHOLES DEEPER THAN 20 FEET SHALL HAVE AN 18" THICK CONCRETE BASE.
  - CONE AND WALL SECTIONS SHALL CONFORM WITH ASTM C-478 STANDARD.
  - ALL MANHOLE TO BE H-20 RATED.

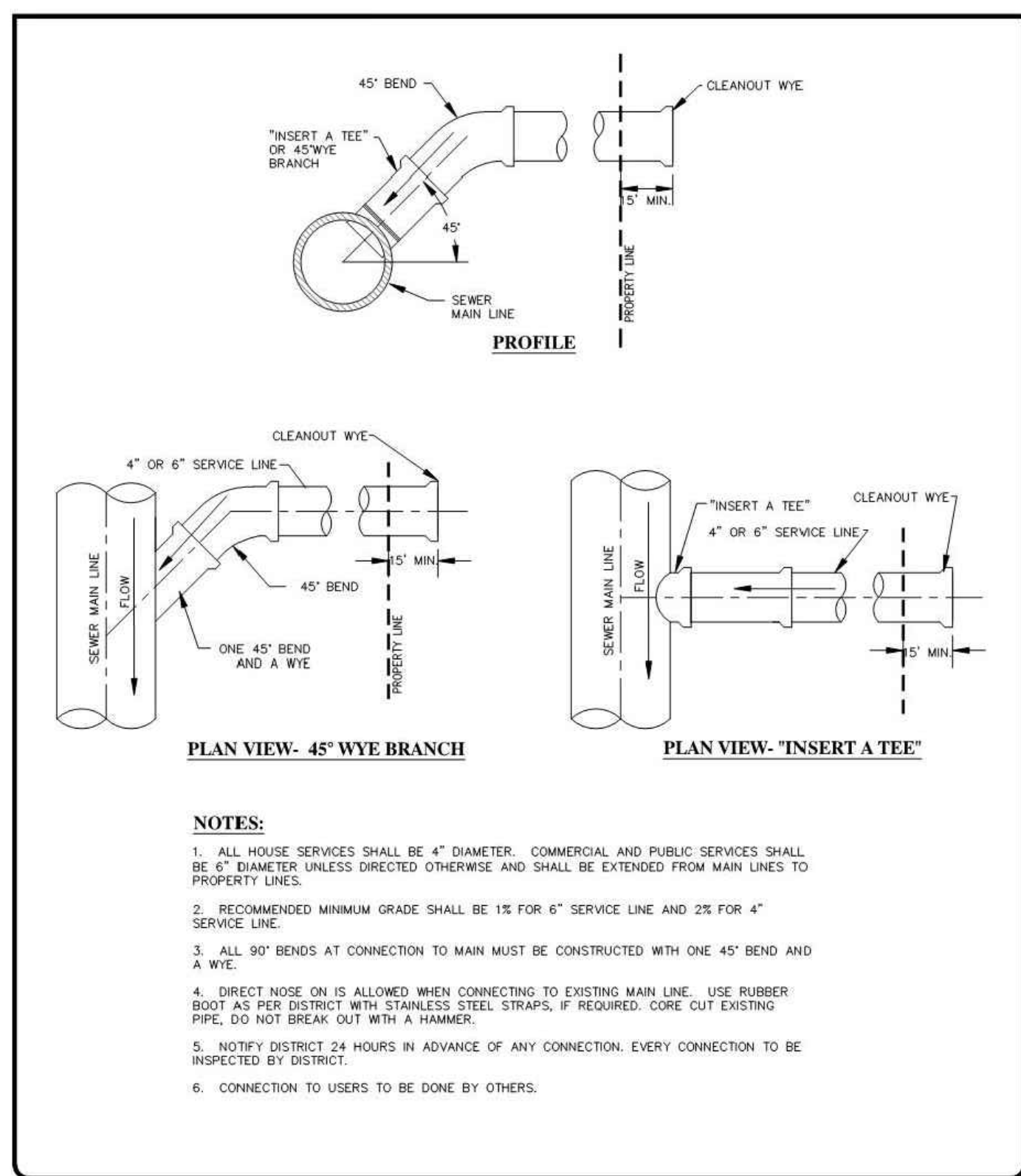

- NOTES:**
- ALL HOUSE SERVICES SHALL BE 4" DIAMETER. COMMERCIAL AND PUBLIC SERVICES SHALL BE 6" DIAMETER UNLESS DIRECTED OTHERWISE AND SHALL BE EXTENDED FROM MAIN LINES TO PROPERTY LINES.
  - RECOMMENDED MINIMUM GRADE SHALL BE 1% FOR 6" SERVICE LINE AND 2% FOR 4" SERVICE LINE.
  - ALL 90° BENDS AT CONNECTION TO MAIN MUST BE CONSTRUCTED WITH ONE 45° BEND AND A WYE.
  - DIRECT NOSE ON IS ALLOWED WHEN CONNECTING TO EXISTING MAIN LINE. USE RUBBER BOOT AS PER DISTRICT WITH STAINLESS STEEL STRAPS, IF REQUIRED. CORE CUT EXISTING PIPE, DO NOT BREAK OUT WITH A HAMMER.
  - NOTIFY DISTRICT 24 HOURS IN ADVANCE OF ANY CONNECTION. EVERY CONNECTION TO BE INSPECTED BY DISTRICT.
  - CONNECTION TO USERS TO BE DONE BY OTHERS.

**STANDARD SEWER TRENCH**  
DATE: APRIL 2011  
DRAWING NAME: SS-1  
DRAWN BY: BFP:JM  
CHECKED BY: APPROVED: [Signature]

**GILSON ENGINEERING**  
Civil, Mechanical & Surveying  
1240 SOUTH 400 EAST BUILDING C, UNIT 2, DRAPER, UT 84040  
PHONE: (801) 571-9444 FAX: (801) 571-9444  
WWW.GILSON.UT

**POWDER MOUNTAIN WATER AND SEWER IMPROVEMENT DISTRICT**  
28 JAH STREET, SUITE 100, OGDEN, UT 84401  
PHONE: (801) 775-1100  
WWW.PMWD.UT

**SANITARY SEWER MANHOLE**  
DATE: APRIL 2011  
DRAWING NAME: SS-2  
DRAWN BY: BFP:JM  
CHECKED BY: APPROVED: [Signature]

**GILSON ENGINEERING**  
Civil, Mechanical & Surveying  
1240 SOUTH 400 EAST BUILDING C, UNIT 2, DRAPER, UT 84040  
PHONE: (801) 571-9444 FAX: (801) 571-9444  
WWW.GILSON.UT

**POWDER MOUNTAIN WATER AND SEWER IMPROVEMENT DISTRICT**  
28 JAH STREET, SUITE 100, OGDEN, UT 84401  
PHONE: (801) 775-1100  
WWW.PMWD.UT

**SEWER SERVICE CONNECTION**  
DATE: APRIL 2011  
DRAWING NAME: SS-3  
DRAWN BY: BFP:JM  
CHECKED BY: APPROVED: [Signature]

**GILSON ENGINEERING**  
Civil, Mechanical & Surveying  
1240 SOUTH 400 EAST BUILDING C, UNIT 2, DRAPER, UT 84040  
PHONE: (801) 571-9444 FAX: (801) 571-9444  
WWW.GILSON.UT

**POWDER MOUNTAIN WATER AND SEWER IMPROVEMENT DISTRICT**  
28 JAH STREET, SUITE 100, OGDEN, UT 84401  
PHONE: (801) 775-1100  
WWW.PMWD.UT

205.3



C702

**TALISMAN**  
CIVIL CONSULTANTS  
1588 SOUTH MAIN STREET  
SUITE 200  
SALT LAKE CITY, UT 84115  
801.743.1300

**POWDER POINT**  
POWDER MOUNTAIN, UTAH  
DETAILS

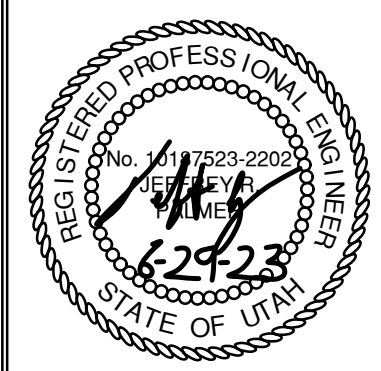

DATE: 06.29.2023

TCC JOB NUMBER: 22-126







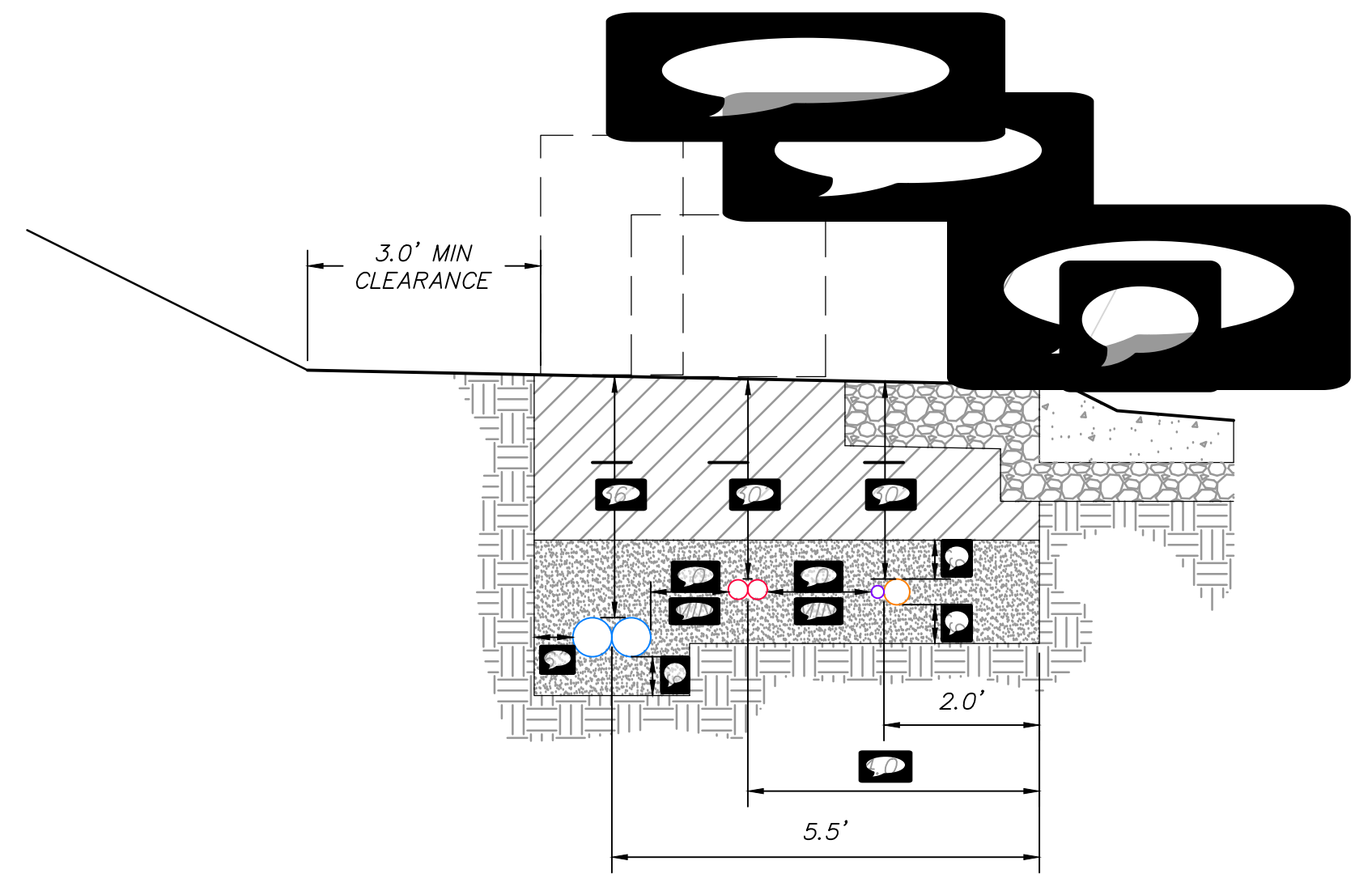
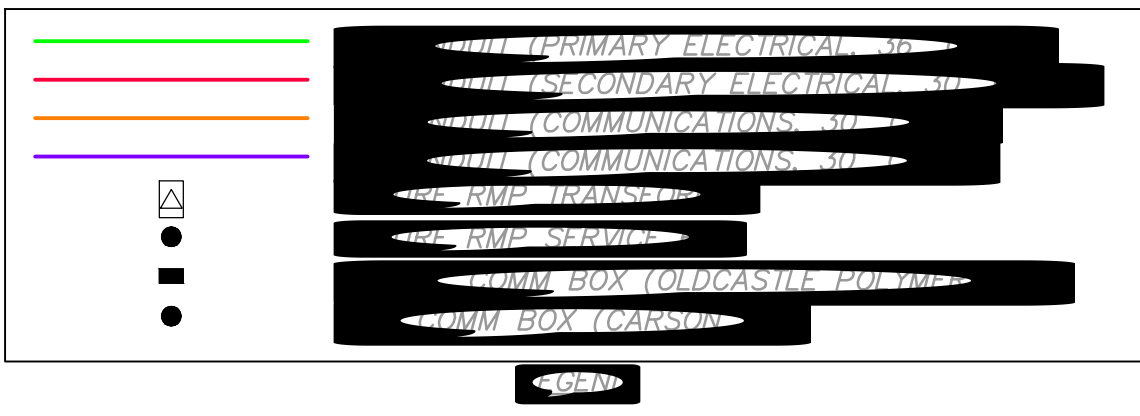
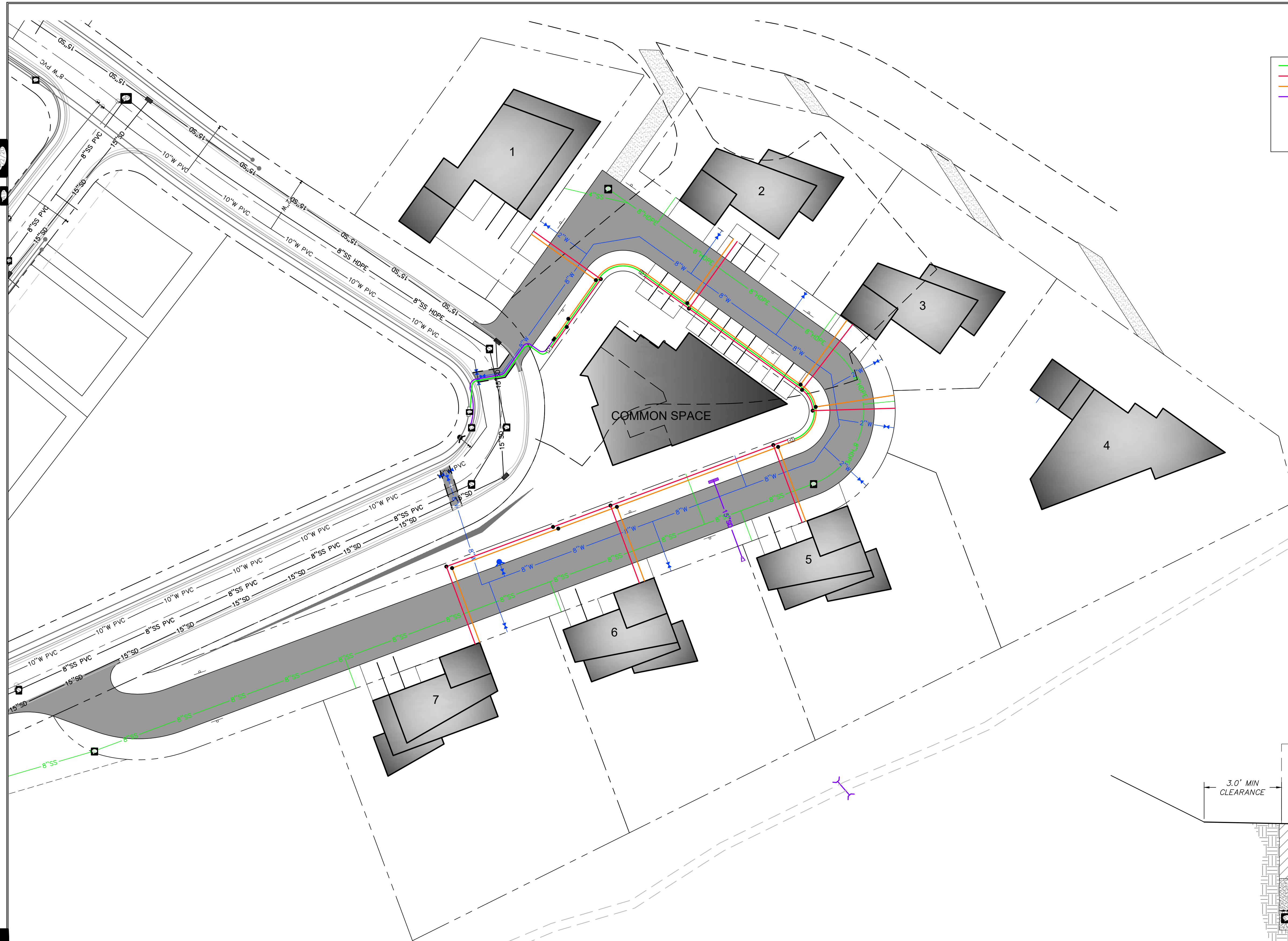

ALL FLAT PULL LINE RATED TO WITHSTAND 1000 LBS OF TENSION WITHIN CONDUITS. PULL LINE FROM EACH END. PULL LINE SHOULD BE CAPPED.

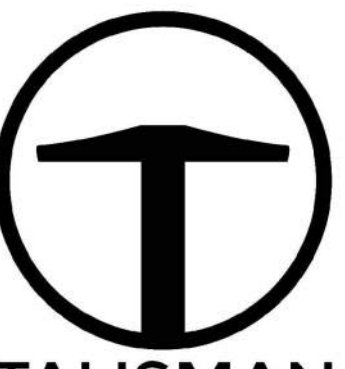

**TALISMAN**  
CIVIL CONSULTANTS  
1588 SOUTH MAIN STREET  
SUITE 200  
SALT LAKE CITY, UT 84115  
801.743.1300

**POWDER POINT**  
POWDER MOUNTAIN, UTAH  
DRY UTILITY PLAN

DATE: 06.29.2023

TCC JOB NUMBER: 22-126

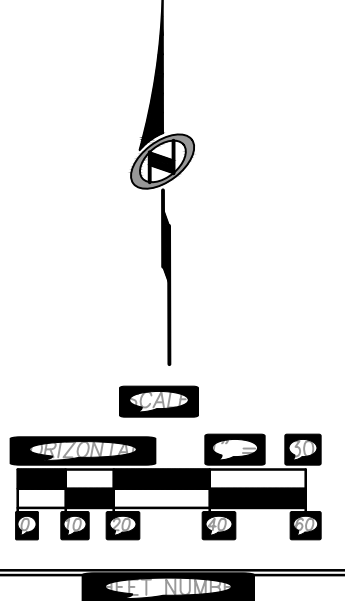

**C800**



## **Appendix I: Construction General Permit**

If all storm water team members access the CGP via the internet while on site, the following link to access the Construction General Permit is sufficient:

<http://construction.stormwater.utah.gov>

STATE OF UTAH  
DEPARTMENT OF ENVIRONMENTAL QUALITY  
DIVISION OF WATER QUALITY  
Utah Pollutant Discharge Elimination System (UPDES)  
General Permit for Storm Water Discharges from Construction Activities  
UPDES Permit No. UTRC00000

This Permit is issued in compliance with the provisions of the Utah Water Quality Act, Title 19, Chapter 5, Utah Code Annotated 2004, as amended (the "Act") and the federal Water Pollution Control Act (33 U.S.c. §§ 1251 et. seq., as amended by the Water Quality Act of 1987, P.L. 100-4), and the rules and Regulations made pursuant to those statutes. This permit authorizes "owners/operators" of construction activities (defined in Part 1.1.1 and Part 10) that meet the requirements of Part 1. of this Utah Pollutant Discharge Elimination System (UPDES) general permit, to discharge pollutants in accordance with the effluent limitations and conditions set forth herein. Permit coverage is required from the "commencement of earth-disturbing activities" (see Part 10) until "final stabilization" (see Part 2.2.14).

This permit becomes effective on July 1, 2019.

This permit and the authorization to discharge expire at midnight on June 30, 2024.

Signed this 18<sup>th</sup> day of June, 2019



Erica Brown Gaddis, PhD  
Director



Table of Contents

**1. COVERAGE UNDER THIS PERMIT ..... 1**

1.1. ELIGIBILITY CONDITIONS ..... 1

1.2. DISCHARGES AUTHORIZED UNDER THIS PERMIT. .... 3

1.3. PROHIBITED DISCHARGES..... 4

1.4. NOTICE OF INTENT (NOI)..... 4

1.5. REQUIREMENT TO POST A NOTICE OF YOUR PERMIT COVERAGE..... 6

**2. TECHNOLOGY-BASED EFFLUENT LIMITATIONS..... 7**

2.1. GENERAL STORM WATER CONTROL DESIGN, INSTALLATION, AND MAINTENANCE REQUIREMENTS. .... 7

2.2. EROSION AND SEDIMENT CONTROL REQUIREMENTS..... 8

2.3. POLLUTION PREVENTION REQUIREMENTS..... 13

**3. WATER QUALITY-BASED EFFLUENT LIMITATIONS. .... 17**

3.1. GENERAL EFFLUENT LIMITATION TO MEET APPLICABLE WATER QUALITY STANDARDS. .... 17

3.2. DISCHARGE LIMITATIONS FOR SITES DISCHARGING TO SENSITIVE WATERS..... 17

**4. SITE INSPECTION REQUIREMENTS. .... 19**

4.1. PERSON(S) RESPONSIBLE FOR INSPECTING THE SITE. .... 19

4.2. FREQUENCY OF INSPECTIONS..... 19

4.3. INCREASE IN INSPECTION FREQUENCY FOR SITES DISCHARGING TO SENSITIVE WATERS..... 19

4.4. REDUCTIONS IN INSPECTION FREQUENCY..... 20

4.5. AREAS THAT MUST BE INSPECTED..... 21

4.6. REQUIREMENTS FOR INSPECTIONS ..... 22

4.7.	INSPECTION REPORT .....	22
4.8.	INSPECTIONS BY DWQ .....	23
5.	CORRECTIVE ACTIONS .....	24
5.1.	CONDITIONS TRIGGERING CORRECTIVE ACTION.....	24
5.2.	CORRECTIVE ACTION DEADLINES .....	24
5.3.	CORRECTIVE ACTION REQUIRED BY DWQ .....	24
5.4.	CORRECTIVE ACTION REPORT .....	24
6.	STAFF TRAINING REQUIREMENTS.....	26
7.	STORM WATER POLLUTION PREVENTION PLAN (SWPPP) .....	27
7.1.	GENERAL REQUIREMENTS.....	27
7.2.	SWPPP WRITER/REVIEWER CERTIFICATION REQUIREMENT .....	27
7.3.	SWPPP CONTENTS. ....	27
7.4.	ON-SITE AVAILABILITY OF YOUR SWPPP .....	33
7.5.	SWPPP MODIFICATIONS. ....	33
8.	HOW TO TERMINATE COVERAGE.....	34
8.1.	MINIMUM INFORMATION REQUIRED IN NOT.....	34
8.2.	CONDITIONS FOR TERMINATING CGP COVERAGE.....	34
8.3.	HOW TO SUBMIT YOUR NOT.....	35
8.4.	DEADLINE FOR SUBMITTING THE NOT. ....	35
8.5.	PARTIAL NOT REQUIREMENTS.....	35
8.6.	EFFECTIVE DATE OF TERMINATION OF COVERAGE. ....	35
9.	STANDARD PERMIT CONDITIONS.....	36
10.	DEFINITIONS AND ACRONYMS.....	40



**Appendix A – BUFFER REQUIREMENTS**

## 1. COVERAGE UNDER THIS PERMIT

To be covered under this permit you must meet the eligibility conditions and follow the requirements for applying for permit coverage in this Part.

### 1.1. ELIGIBILITY CONDITIONS

**1.1.1. All “operators”** of a construction site must sign on the notice of intent or NOI (see part 1.4 for NOI). Owners (or lessee’s) and general contractors are both considered “operators” for the purposes of this permit (see definition of “operator” in Part 10). Except for areas listed in part 1.2.2, this permit does not cover area that is not legally owned or leased by the operator defined in Part 10, that has operational control over construction plans and specifications.

#### 1.1.2. The Project:

- a. A project covered by this permit will **disturb 1 or more acres** of land, or will disturb less than 1 acre of land but be part of a common plan of development or sale<sup>1</sup> that will ultimately disturb 1 or more acres of land; or
- b. A project’s **discharges have been designated** by the Director as needing a permit under UAC 317-8-3.9(1)(a)5. or UAC 317-8-3.9(6)(e)2.
- c. **Single lot residential projects** that disturb **less than 1 acre** of land and are part of a common plan of development or sale may be covered under the Common Plan Permit (UTRH00000) in lieu of this permit. Information on this permit can be found on the DWQ construction storm water web site at <https://deq.utah.gov/legacy/permits/water-quality/utah-pollutant-discharge-elimination-system/storm-water-general-construction.htm>.
- d. Projects **less than five acres** with a **rainfall erosivity factor** (“R” in the revised universal soil loss equation, or RUSLE) value of **less than five** during the period of construction activity may waive the requirements of this permit by submitting an **Erosivity Waiver Certification**. Information on the Erosivity Waiver can be found on the DWQ construction storm water web site at <https://deq.utah.gov/legacy/permits/water-quality/utah-pollutant-discharge-elimination-system/storm-water-general-construction.htm>.

**1.1.3. A project is located** within the state of Utah, except for Indian Country (Storm water permits for Indian Country within the State must be acquired through EPA Region VIII, except for facilities on the Navajo Reservation or on the Goshute Reservation which must acquire storm water permits through EPA Region IX).

#### 1.1.4. Discharges from a project cannot;

- a. **already have coverage** under the UPDES CGP or any other UPDES permit for a storm water discharge associated with construction activity (UPDES wastewater and industrial permit coverage for separate discharges associated with the site is allowed) or,

---

<sup>1</sup> See definition for common plan of development or sale in Part 10

- b. **be in the process of receiving coverage** under a different UPDES permit for a storm water discharge from construction activities that has been denied, terminated, or revoked<sup>2</sup>,
- c. **be treated with “cationic treatment chemicals”** (see Definitions) unless and until you notify DWQ in advance of receiving permit coverage and have received written approval. To be able to use “cationic treatment chemicals” you must demonstrate to DWQ that appropriate controls and implementation procedures are used to ensure that your use of cationic treatment chemicals will not lead to discharges that cause an exceedance of water quality standards or harm fish populations.

**1.1.5. Eligibility for Emergency-Related Construction Activities.** If you are conducting earth-disturbing activities in response to a public emergency (e.g., natural disaster, widespread disruption in essential public services), and the related work requires immediate authorization to avoid imminent endangerment to human health, public safety, or the environment, or to reestablish public services, your requirements are:

- a. If the emergency related activity is accomplished within 30-days you are waived from the normal requirements to submit an NOI and prepare a SWPPP, but you must submit a report to DWQ within 45-days and show:
  - (1) the nature of the emergency work performed,
  - (2) a description of earth disturbances that occurred,
  - (3) the proximity of the work to waters of the State, and what was done to protect water quality during the emergency work, and
  - (4) the occurrence of the public emergency must be substantiated.
- b. If the emergency activity continues longer than 30-days you are authorized to discharge on the condition that a complete and accurate NOI is submitted within 30 calendar days after commencing earth-disturbing activities establishing that you are eligible under this permit. You are also required to provide emergency documentation in your SWPPP to substantiate the occurrence of the public emergency.

**1.1.6. Water Quality Standards – Eligibility for New Sources.** If you are a “new source” (as defined in Part 10), you are not eligible for coverage under this permit for discharges that have the reasonable potential to cause, or contribute to an excursion above any applicable water quality standard. Where such a determination is made, adjustments must be made to storm water controls to bring the discharge into compliance with water quality standards immediately or permit coverage will be rescinded. DWQ expects that compliance with the storm water control requirements of this permit, including the requirements applicable to such discharges in Part 3.2, will result in discharges that will not cause, have the reasonable potential to cause, or contribute to an excursion above any applicable water quality standard.

---

<sup>2</sup> Projects having been denied, terminated, or revoked must resolve the problem causing the ineligibility before the same or other coverage will be restored.



**1.1.7. Discharging to Waters with High Water Quality – Eligibility for New Sources.** If you are a “new source” (as defined in Part 10), you are eligible to discharge to a Category 1 water if your discharge is temporary and limited and where best management practices will be employed to minimize pollution effects, to a Category 2 water only if your discharge will not lower the water quality of the applicable water body. In the absence of information demonstrating otherwise, DWQ expects that compliance with the storm water control requirements of this permit, including the requirements applicable to such discharges in Part 3.2, will result in discharges that will not lower the water quality of the applicable water.

Your project will be considered to discharge to a Category 1 or 2 water if the first surface water to which you discharge is identified by the state as a Category 1 or 2 water. For discharges that enter a storm sewer system prior to discharge, the first surface water to which you discharge is the water body that receives the storm water discharge from the storm sewer system. Please refer to water quality information at <http://mapserv.utah.gov/surfacewaterquality/>

**1.2. DISCHARGES AUTHORIZED UNDER THIS PERMIT.** The following is a list of discharges that are allowed under this permit provided that appropriate storm water controls are designed, installed, and maintained:

**1.2.1.** Storm water discharges, including **storm water, snowmelt, and surface water runoff and drainage**, associated with construction activity under UAC R317-8-3.9(6)(d)10. or UAC R317-8-3.9(6)(e)1.;

**1.2.2.** Storm water discharges from **construction support activities** (e.g., concrete or asphalt batch plants, equipment staging yards, material storage areas, excavated material disposal areas, borrow areas) provided:

- a. The support **activity is directly related to the construction site** required to have permit coverage for storm water discharges;
- b. The support activity **does not serve multiple unrelated construction projects**;
- c. The support activity **does not continue to operate beyond the completion of the construction activity** at the project it supports; and
- d. Storm water controls are implemented in accordance with Part 2 and, if applicable, Part 3, for discharges from the support activity areas.

**1.2.3. The following non-storm water discharges** from your construction activity are allowed under this permit, provided that you comply with all applicable requirements for these discharges in Part 2:

- a. Discharges from emergency fire-fighting activities;
- b. Fire hydrant flushings;
- c. Properly managed landscape irrigation;
- d. Water used to wash vehicles and equipment, provided that there is no discharge of soaps, solvents, or detergents used for such purposes;
- e. Water used to control dust;

- f. Potable water including uncontaminated water line flushings;
  - g. External building washdown, provided soaps, solvents, and detergents are not used, and external surfaces do not contain hazardous substances;
  - h. Pavement wash waters, provided spills or leaks of toxic or hazardous materials have not occurred (unless all spill material has been removed) and where detergents (including biodegradable soy bean oils and biodegradable detergents) are not used. You are prohibited from directing pavement wash waters directly into any surface water, storm drain inlet, or storm water conveyance unless the conveyance is connected to a sediment basin, sediment trap, or similarly effective control for the pollutants present. Per 2.2.5.d., hosing of accumulated sediments on pavement into any storm water conveyance is prohibited;
  - i. Uncontaminated air conditioning or compressor condensate;
  - j. Uncontaminated, non-turbid discharges of ground water (from natural sources) or spring water; and,
  - k. Foundation or footing drains where flows are not contaminated with process materials such as solvents, contaminated ground water, or sediment from construction activity.
- 1.2.4.** Comingling of the non-storm water discharges above with other permitted discharges is also authorized.
- 1.2.5. Discharging of construction dewatering** (groundwater that intersects with excavation) must be permitted under UTG070000 (Construction Dewatering and Hydrostatic Test Permit), and the Municipal Separate Storm Sewer System (MS4) (of jurisdiction) notified of the discharge. Permitting is not required under UTG070000 if the construction dewatering does not leave the site (it is percolated into the ground on site).

**1.3. PROHIBITED DISCHARGES.**

- 1.3.1.** Wastewater from washing tools and vehicles after pouring, prepping, or finishing concrete.
- 1.3.2.** Wastewater from washing and cleanout of stucco, paint, concrete, form release oils, curing compounds, and other construction materials;
- 1.3.3.** Fuels, oils, or other pollutants used in vehicle and equipment operation and maintenance;
- 1.3.4.** Soaps, solvents, or detergents used in vehicle and equipment washing or external building washdown; and
- 1.3.5.** Toxic or hazardous substances from a spill or other release.

To prevent the above-listed prohibited non-storm water discharges, operators must comply with the applicable pollution prevention requirements in Part 2.3.

- 1.4. NOTICE OF INTENT (NOI).** To be covered under this permit, you must develop a SWPPP (see part 7.1), submit a complete and accurate NOI, and remit the permit fee. The permit fee covers a year of permit coverage. If a project extends more than a year the permit must be renewed and the permit fee must be remitted again.

There is a 60-day grace period after the permit expiration date where projects may be completed or the permit renewed.

All NOI applications and project storm water compliance plans must also be submitted to regulated MS4s (see the list of municipalities on the DWQ municipal storm water web site <https://deq.utah.gov/legacy/permits/water-quality/utah-pollutant-discharge-elimination-system/storm-water-municipal.htm>). Not all municipalities are regulated MS4s (see definitions Part 10).

**1.4.1. How to Submit Your NOI.** NOIs and permit fees may be submitted online at <https://secure.utah.gov/stormwater>. A paper copy of the NOI form may be downloaded from the DWQ construction storm water web site at <https://deq.utah.gov/legacy/permits/water-quality/utah-pollutant-discharge-elimination-system/storm-water-general-construction.htm>, of which the NOI form and permit fee may be mailed to:

Division of Water Quality  
PO Box 144870  
Salt Lake City, Utah 84114-4870

**1.4.2. Start and End of Permit Coverage and Deadlines.** Coverage under a permit must be obtained before soil disturbing activities begin. The permit is effective immediately after the NOI has been successfully entered into the storm water database and the permit fee is paid. Active coverage may be affected by the following conditions:

- a. a notice of termination (NOT) is submitted.
- b. the yearly permit fee is kept current and renewed year by year for the period of construction activity,
- c. when this general permit (UTRC00000) expires, if no arrangement has been made for continuing coverage, NOIs may need to be submitted for continuing coverage under a new or reissued replacement permit,
- d. coverage under the CGP is rescinded or revoked for the project site for administrative reasons for which the permittee will be notified in writing, or
- e. if all storm water discharges for the site are permitted under a different general or individual UPDES permit, this permit is terminated on the day the other permit coverage begins.

**1.4.3. Exception to NOI Deadline for “Existing Permits”.** Existing permits are construction projects with soil disturbances that require coverage under a UPDES construction storm water permit, and which had active coverage under UTRC00000 at the time of expiration of that general permit, or that received coverage before this permit was issued. Existing projects may be automatically covered under this permit. Permittees will be contacted with the email address listed on their NOI if further action is needed. **Existing projects have 3 months** from the issuance of this permit to update site storm water controls and the site SWPPP to meet requirements in this permit.

**1.4.4. Continuation of Coverage After this Permit Expires.** If this permit is not reissued or replaced by the expiration date, it will be administratively extended by the Director and remain in force and effect until issuance of a comparable CGP. Permit coverage will continue under this permit until the earliest of:



- a. authorization of, and an application process, is provided for coverage under a reissued or replacement version of this permit; or
- b. the permittee's submittal of a Notice of Termination; or
- c. the issuance of an individual permit or denial of coverage (see part 1.4.4 below) for the project's discharges.

DWQ reserves the right to modify or revoke and reissue this permit under UAC317-8-5.6, in which case you will be notified of any relevant changes to which you may be subject.

**1.4.5. Procedures for Denial of Coverage.** Following a submittal of a complete and accurate NOI, you may be notified in writing by DWQ that you are not covered, and that you must either apply for and/or obtain coverage under an individual UPDES permit or an alternate general UPDES permit. This notification will include a brief statement of the reasons for this decision and will provide application information. Any interested person may request that DWQ consider requiring an individual permit under this paragraph.

If you are already a permittee with coverage under this permit, the notice will set a deadline to file the permit application, and will include a statement that on the effective date of the individual UPDES permit or alternate general UPDES permit, as it applies to you, coverage under this general permit will terminate. DWQ may grant additional time to submit the application if requested. If you are covered under this permit and fail to submit an individual UPDES permit application or an NOI for an alternate general UPDES permit as required by DWQ, then the applicability of this permit to your site is terminated at the end of the day specified by DWQ as the deadline for application submittal. DWQ may take appropriate enforcement action for any unpermitted discharge. If you submit a timely permit application, then when an individual UPDES permit is issued to you or you are provided with coverage under an alternate general UPDES permit, your coverage under this permit is terminated on the effective date of the individual permit or date of coverage under the alternate general permit.

**1.5. REQUIREMENT TO POST A NOTICE OF YOUR PERMIT COVERAGE** All permitted sites must have a sign posted in a conspicuous, safe, publically accessible place and near the entrance to the project. The font on the sign must large enough for normal corrected vision to easily read the sign contents from a public right-of-way. At a minimum, the notice must include:

- 1.5.1.** the UPDES Permit tracking number,
- 1.5.2.** the name of a contact person for questions, SWPPP requests, or information about the project,
  - a. the contact phone number (must be available during business hours) or
  - b. an email address (must be checked and responded to within 24-hours on week days).

- 2. TECHNOLOGY-BASED EFFLUENT LIMITATIONS.** You must comply with the following technology-based effluent limitations in this Part.
- 2.1. GENERAL STORM WATER CONTROL DESIGN, INSTALLATION, AND MAINTENANCE REQUIREMENTS.** You must design, install, and maintain storm water controls required in Parts 2.2 and 2.3 to minimize the discharge of pollutants in storm water from construction activities. To meet this requirement, you must:
- 2.1.1. Account for the following factors in designing your storm water controls:**
- a. The expected amount, frequency, intensity, and duration of precipitation;
  - b. The nature of storm water runoff and run-on at the site, including factors such as expected flow from impervious surfaces, slopes, and site drainage features. You must design storm water controls to control storm water volume, velocity, and peak flow rates to minimize discharges of pollutants in storm water and to minimize channel and streambank erosion and scour in the immediate vicinity of discharge points; and
  - c. The soil type and range of soil particle sizes expected to be present on the site.
- 2.1.2. Design and install all storm water controls** in accordance with good engineering practices, including applicable design specifications (see manufacturer specifications and/or applicable erosion and sediment control manuals or ordinances – departures from such specifications must reflect good engineering practices and must be explained in your SWPPP).
- 2.1.3. Complete installation of storm water controls** by the time each phase of construction activities has begun.
- a. Before construction activity in any given portion of the site begins, install and make operational any downgradient sediment controls (e.g., buffers, perimeter controls, exit point controls, storm drain inlet protection).
  - b. Following the installation of storm water controls for the initial construction activities (e.g., clearing, grading, excavating), adjust storm water control and management strategies throughout the project to meet and match the needs for each phase of construction, if applicable, as the project progresses towards completion.
- 2.1.4. Ensure that all storm water controls are maintained, remain in effective operating condition during permit coverage, and are protected from activities that would reduce their effectiveness.**
- a. Comply with any specific maintenance requirements for the storm water controls listed in this permit. Regular maintenance is expected and is not limited to response actions from inspections or identified problems.
  - b. Follow maintenance recommendations from the manufacturer or utilize good engineering practices based on site conditions and document deviations from manufacture recommendations.
  - c. Any time maintenance issues are discovered in storm water controls, make repairs immediately if practical, prior to weather or activities utilizing the control, or within seven business days, whichever comes first.

- d. Any time you find that a storm water control needs to be installed (where none had previously been), replaced, or removed, you must record the corrective action as required in Part 5.

**2.2. EROSION AND SEDIMENT CONTROL REQUIREMENTS.** You must implement erosion and sediment controls in accordance with the following requirements to minimize the discharge of pollutants in storm water from construction activities.

**2.2.1. Provide and maintain natural buffers and/or equivalent** erosion and sediment controls when a water of the state is located within 50 feet of the site's earth disturbances. Additional guidance for buffers is provided in Appendix A.

- a. Compliance Alternatives. For any discharges to waters of the State located within 50 feet of your site's earth disturbances, you must comply with one of the following alternatives:
  - (1) Provide and maintain a 50-foot undisturbed natural buffer; or
  - (2) Provide and maintain an undisturbed natural buffer that is less than 50 feet and is supplemented by erosion and sediment controls that achieve, in combination, the sediment load reduction equivalent to a 50-foot undisturbed natural buffer; or
  - (3) If infeasible to provide and maintain an undisturbed natural buffer of any size, implement erosion and sediment controls to achieve the sediment load reduction equivalent to a 50-foot undisturbed natural buffer.

b. See Appendix A, Part A.2.2. for exceptions to the compliance alternatives.

**2.2.2. Preserve naturally vegetated areas where possible and, if feasible, direct storm water to these areas to maximize storm water infiltration and filtering to reduce pollutant discharges.**

**2.2.3. Install sediment controls along any perimeter areas of the site that will receive pollutant discharges.**

- a. Remove sediment before it has accumulated to the point where the control has become ineffective. Often that is one-half of the above-ground height of any perimeter control.
- b. **Exception.** For areas at "linear construction sites" (as defined in Part 10) where perimeter controls are infeasible (e.g., due to a limited or restricted right-of-way), implement other practices as necessary to minimize pollutant discharges to perimeter areas of the site.

**2.2.4. Minimize sediment track-out.**

- a. **Restrict vehicle use to properly designated exit points;**
- b. Use appropriate stabilization techniques at all points that exit onto paved roads<sup>3</sup>.
  - (1) **Exception:** Stabilization is not required for exit points at linear utility construction sites that are used only episodically and for very short durations over the life of the project, provided other exit point controls<sup>4</sup> are implemented to minimize sediment track-out;

---

<sup>3</sup> An example of appropriate stabilization techniques is the use of aggregate stone with an underlying geotextile or non-woven filter fabric, and turf mats.



- c. Implement additional track-out controls<sup>5</sup> as necessary to ensure that sediment removal occurs prior to vehicle exit; and
- d. Where sediment has been tracked-out from your site onto paved roads, sidewalks, or other paved areas outside of your site, you must remove deposited sediment before it accumulates significantly and is tracked beyond the immediate vicinity of the project. Frequency of removal is dependent on site conditions, whatever is necessary to control off site tracking. . Remove the track-out by sweeping, shoveling, or vacuuming these surfaces, or by using other similarly effective means of sediment removal. You are prohibited from hosing or sweeping tracked-out sediment into any storm water conveyance, storm drain inlet, or water of the state<sup>6</sup>.

**2.2.5. Manage stockpiles or land clearing debris piles composed, in whole or in part, of sediment and/or soil:**

- a. Locate the piles outside of any natural buffers established under Part 2.2.1 and away from any storm water conveyances, drain inlets, and areas where storm water flow is concentrated;
- b. Install a sediment barrier along all downgradient perimeter areas;<sup>7</sup>
- c. For piles that will be unused for 14 or more days and are stored in areas that are being inspected at a reduced frequency due to temporary stabilization or frozen conditions (Part 4.4.1. and 4.4.3.), provide cover<sup>8</sup> or appropriate temporary stabilization (consistent with Part 2.2.14);
- d. You are prohibited from hosing down or sweeping soil or sediment accumulated on pavement or other impervious surfaces into any storm water conveyance, storm drain inlet, or water of the state.
- e. Where practicable, contain and securely protect from wind.

**2.2.6. Minimize dust.** On areas of exposed soil, minimize the generation of dust through the appropriate application of water or other dust suppression techniques.

**2.2.7. Minimize steep slope disturbances.** Minimize the disturbance of “steep slopes” (as defined in Part 10).

**2.2.8. Preserve native topsoil,<sup>9</sup> unless infeasible.**

---

<sup>4</sup> Examples of other exit point controls include preventing the use of exit points during wet periods; minimizing exit point use by keeping vehicles on site to the extent possible; limiting exit point size to the width needed for vehicle and equipment usage; using scarifying and compaction techniques on the soil; and avoiding establishing exit points in environmentally sensitive areas (e.g., karst areas; steep slopes).

<sup>5</sup> Examples of additional track-out controls include the use of wheel washing, rumble strips, and rattle plates.

<sup>6</sup> Fine grains that remain visible (i.e., staining) on the surfaces of off-site streets, other paved areas, and sidewalks after you have implemented sediment removal practices are not a violation of Part 2.2.4.

<sup>7</sup> Examples of sediment barriers include berms, dikes, fiber rolls, silt fences, sandbags, gravel bags, or straw bale.

<sup>8</sup> Examples of cover include tarps, blown straw and hydromulching.

<sup>9</sup> Stockpiling topsoil at off-site locations, or transferring topsoil to other locations, is an example of a practice that is consistent with the requirements in Part 2.2.8. Preserving native topsoil is not required where the intended function of a specific area of the site dictates that the topsoil be disturbed or removed. For example, some sites may be designed to be highly impervious after construction, and therefore little or no vegetation is intended to remain, or may not have space to stockpile native topsoil on site for later use, in which case, it may not be feasible to preserve topsoil.

**2.2.9. Minimize soil compaction<sup>10</sup>** in areas of your site where final vegetative stabilization will occur or where infiltration practices will be installed:

- a. Restrict vehicle and equipment use in these locations to avoid soil compaction; and
- b. Before seeding or planting areas of exposed soil that have been compacted, use techniques that rehabilitate and condition the soils as necessary to support vegetative growth.

**2.2.10. Protect storm drain inlets.**

- a. Install inlet protection measures that remove sediment from discharges prior to entry into any storm drain inlet that carries storm water flow from your site to a surface water of the state, provided you have authority to access the storm drain inlet;<sup>11</sup> and
- b. Clean, or remove and replace, the protection measures as sediment accumulates, the filter becomes clogged, and/or performance is compromised. Where there is evidence of sediment accumulation adjacent to the inlet protection measure, remove the deposited sediment by the end of the same business day in which it is found.

**2.2.11. Minimize erosion of storm water conveyance channels and their embankments, outlets, adjacent streambanks, slopes, and downstream waters.** Use erosion controls and velocity dissipation devices<sup>12</sup> within and along the length of any storm water conveyance channel and at any outlet to slow down runoff to minimize erosion.

**2.2.12. If you install a sediment basin or similar impoundment:**

- a. Situate the basin or impoundment outside of any water of the state and any natural buffers established under Part 2.2.1;
- b. Design the basin or impoundment to avoid collecting water from wetlands;
- c. Design the basin or impoundment to provide storage for either:
  - (1) The calculated volume of runoff from a 2-year, 24-hour storm; or
  - (2) 3,600 cubic feet per acre drained.
- d. Utilize outlet structures that withdraw water from near the surface of the sediment basin or similar impoundment, unless infeasible;<sup>13</sup>
- e. Use erosion controls and velocity dissipation devices to prevent erosion at inlets and outlets; and
- f. Remove accumulated sediment to maintain at least one-half of the design capacity and conduct all other appropriate maintenance to ensure the basin or impoundment remains in effective operating condition.

---

<sup>10</sup> Minimizing soil compaction is not required where the intended function of a specific area of the site dictates that it be compacted.

<sup>11</sup> Inlet protection measures can be removed in the event of flood conditions or to prevent erosion

<sup>12</sup> Examples of velocity dissipation devices include check dams, sediment traps, riprap, and grouted riprap at outlets.

<sup>13</sup> The circumstances in which it is infeasible to design outlet structures in this manner are rare. A possible exception is dealing with or treating for temperature, but there may be other reasons. If you determine that it is infeasible to meet this requirement, you must provide documentation in your SWPPP to support your determination, including the specific conditions or time periods when this exception will apply.

**2.2.13. If using treatment chemicals** (e.g., polymers, flocculants, coagulants):

- a. **Use conventional erosion and sediment controls before and after the application of treatment chemicals.** Chemicals may only be applied where treated storm water is directed to a sediment control (e.g., sediment basin, perimeter control) before discharge.
- b. **Select appropriate treatment chemicals.** Chemicals must be appropriately suited to the types of soils likely to be exposed during construction and present in the discharges being treated (i.e., the expected turbidity, pH, and flow rate of storm water flowing into the chemical treatment system or area).
- c. **Minimize discharge risk from stored chemicals.** Store all treatment chemicals in leak-proof containers that are kept under storm-resistant cover and surrounded by secondary containment structures (e.g., spill berms, decks, spill containment pallets), or provide equivalent measures designed and maintained to minimize the potential discharge of treatment chemicals in storm water or by any other means (e.g., storing chemicals in a covered area, having a spill kit available on site and ensuring personnel are available to respond expeditiously in the event of a leak or spill).
- d. **Comply with state/local requirements.** Comply with applicable state and local requirements regarding the use of treatment chemicals.
- e. **Use chemicals in accordance with good engineering practices and specifications of the chemical provider/supplier.** Use treatment chemicals and chemical treatment systems in accordance with good engineering practices, and with dosing specifications and sediment removal design specifications provided by the provider/supplier of the applicable chemicals, or document in your SWPPP specific departures from these specifications and how they reflect good engineering practice. Consider changing site conditions that may affect dosing levels such as temperature.
- f. **Ensure proper training.** Ensure that all persons who handle and use treatment chemicals at the construction site are provided with appropriate, product-specific training. Among other things, the training must cover proper dosing requirements.
- g. **Perform additional measures specified by DWQ for the authorized use of cationic chemicals.** If you have been authorized to use cationic chemicals at your site pursuant to Part 1.1.4.c, you must perform all additional measures as conditioned by your authorization to ensure that the use of such chemicals will not cause an exceedance of water quality standards or harm fish populations.

**2.2.14. Stabilize exposed portions of the site.** Implement and maintain stabilization measures (e.g., seeding protected by erosion controls until vegetation is established, sodding, mulching, erosion control blankets, hydromulch, gravel) that minimize erosion from exposed portions of the site in accordance with Parts 2.2.14.a and 2.2.14.b.

a. **Stabilization Deadlines:**

- (1) Initiate the installation of stabilization measures in any areas of exposed soil where construction activities have permanently ceased or will be temporarily inactive for 14 or more calendar days as soon as possible and prior to the end of the 14<sup>th</sup> day of inactivity; and



(2) Complete the installation of stabilization measures as soon as practicable, but no later than 14 calendar days after stabilization has been initiated.<sup>14</sup>

(3) **Exceptions:**

(i) Arid, semi-arid, and drought-stricken areas<sup>15</sup> (as defined in Part 10). Where a project is an arid, semi-arid, or a seasonally dry period or a period in which drought is occurring, and vegetative stabilization measures are being used:

(1) Initiate as soon as practicable and, within 14 calendar days of a temporary or permanent cessation of work in any portion of your site, complete the installation of temporary non-vegetative stabilization measures to the extent necessary to prevent erosion;<sup>16</sup>

(2) As soon as practicable, given conditions or circumstances on the site, complete all activities necessary to seed or plant the area to be stabilized; and

(3) If construction is occurring during the seasonally dry period<sup>17</sup>, indicate in your SWPPP the beginning and ending dates of the seasonally dry period and your site conditions. Also include the schedule you will follow for initiating and completing vegetative stabilization.

(ii) **Discharges to a sediment- or nutrient-impaired water** (a water having a TMDL identifying sediment or nutrients as the cause of impairment) or to a water that is high quality for antidegradation purposes (see part 3). Complete stabilization as soon as practicable, but no later than seven (7) calendar days after stabilization has been initiated.

b. **Final Stabilization Criteria** (for any areas not covered by permanent structures):

(i) Establish uniform, perennial vegetation (i.e., evenly distributed, without large bare areas) that provides 70 percent or more of the vegetative cover that was provided by vegetation prior to commencing earth-disturbing activities; and/or

(ii) Implement permanent non-vegetative stabilization measures<sup>18</sup> to provide effective cover.

(iii) **Exceptions:**

(1) **Arid, semi-arid, and drought-stricken areas** (as defined in Part 10). Final stabilization is met if the area has been seeded or planted in a manner that vegetation is expected to be

---

<sup>14</sup> If vegetative stabilization measures are being implemented, stabilization is considered “installed” when all activities necessary to seed or plant the area are completed. If non-vegetative stabilization measures are being implemented, stabilization is considered “installed” when all such measures are implemented or applied.

<sup>15</sup> If you are in an area receiving more than 20 inches of average annual precipitation that is in a drought (as determined by the NOAA drought predictor <http://www.cpc.ncep.noaa.gov/products/Drought/>) and a seasonal dry period, to comply with drought conditions you must identify the normal seasonal dry period in the SWPPP.

<sup>16</sup> The extent necessary to prevent erosion in arid and semi-arid areas means for visually flat areas, stabilization is not required (roughly from 0 percent up to 5 percent) unless an erosion concern exists. Areas with slopes roughly 5 percent to 20 percent must have, at minimum, controls to reduce storm water velocities to a point that erosion is controlled. Over a 20 percent slope requires soil surface stabilization. The amount of stabilization provided must increase commensurately with increasingly steeper slopes.

<sup>17</sup> The lower elevations of the Wasatch Front are semi-arid, the seasonal dry period for the Wasatch Front is June, July, and August.

<sup>18</sup> Examples of permanent non-vegetative stabilization measures include riprap, gravel, gabions, and geotextiles.

established within three (3) years which provides 70 percent or more of the cover that was provided by vegetation prior to commencing earth disturbing activities and, to the extent necessary to prevent erosion on the seeded or planted area, non-vegetative erosion controls meet standards in footnote 16.

- (2) Disturbed areas on agricultural land that are restored to their preconstruction agricultural use. The Part 2.2.14b final stabilization criteria does not apply.
- (3) Areas that need to remain disturbed. In limited circumstances, stabilization may not be required if the intended function of a specific area of the site necessitates that it remain disturbed, and only the minimum area needed remains disturbed (e.g., dirt access roads, utility pole pads, areas being used for storage of vehicles, equipment, materials).

**2.3. POLLUTION PREVENTION REQUIREMENTS:** Implement pollution prevention controls in accordance with the following requirements to minimize the discharge of pollutants in storm water and to prevent the discharge of pollutants from spilled or leaked materials from construction activities.

**2.3.1. For equipment and vehicle fueling and maintenance:**

- a. Provide an effective means of eliminating the discharge of spilled or leaked chemicals, including fuels and oils, from these activities;<sup>19</sup>
- b. If applicable, comply with the Spill Prevention Control and Countermeasures (SPCC) requirements in 40 CFR part 112 and Section 311 of the CWA;
- c. Ensure adequate supplies are available at all times to handle spills, leaks, and disposal of used liquids;
- d. Use drip pans and absorbents under or around leaky vehicles;
- e. Dispose of or recycle oil and oily wastes in accordance with other federal, state, tribal, or local requirements; and
- f. Clean up spills or contaminated surfaces immediately, using dry clean up measures (do not clean contaminated surfaces by hosing the area down), and eliminate the source of the spill to prevent a discharge or a continuation of an ongoing discharge.

**2.3.2. For equipment and vehicle washing:**

- a. Provide an effective means of minimizing the discharge of pollutants from equipment and vehicle washing, wheel wash water, and other types of wash waters;<sup>20</sup>

---

<sup>19</sup> Examples of effective means include:

- Locating activities away from waters of the state and storm water inlets or conveyances so that storm water coming into contact with these activities cannot reach waters of the state;
- Providing secondary containment (e.g., spill berms, decks, spill containment pallets) and cover where appropriate; and
- Having a spill kit available on site and ensuring personnel are available to respond expeditiously in the event of a leak or spill.

- b. Ensure there is no discharge of soaps, solvents, or detergents in equipment and vehicle wash water; and
- c. For storage of soaps, detergents, or solvents, provide either (1) cover (e.g., plastic sheeting, temporary roofs) to minimize the exposure of these detergents to precipitation and to storm water, or (2) a similarly effective means designed to minimize the discharge of pollutants from these areas.

**2.3.3. For storage, handling, and disposal of building products and materials:**

- a. For building materials and building products<sup>21</sup> that have the potential to mobilize or release pollutants, provide either (1) cover (e.g., plastic sheeting, temporary roofs) to minimize the exposure of these products to precipitation and to storm water, or (2) a similarly effective means designed to minimize the discharge of pollutants from these areas.
- b. **For pesticides, herbicides, insecticides, fertilizers, and landscape materials:**
  - (1) In storage areas, provide either (1) cover (e.g., plastic sheeting, temporary roofs) to minimize the exposure of these chemicals to precipitation and to storm water, or (2) a similarly effective means designed to minimize the discharge of pollutants from these areas; and
  - (2) Comply with all application and disposal requirements included on the registered pesticide, herbicide, insecticide, and fertilizer label (see also Part 2.3.5).
- c. **For diesel fuel, oil, hydraulic fluids, other petroleum products, and other chemicals:**
  - (1) Store chemicals in water-tight containers, and provide either (1) cover (e.g., plastic sheeting, temporary roofs) to minimize the exposure of these containers to precipitation and to storm water, or (2) a similarly effective means designed to minimize the discharge of pollutants from these areas (e.g., having a spill kit available on site and ensuring personnel are available to respond expeditiously in the event of a leak or spill), or provide secondary containment (e.g., spill berms, decks, spill containment pallets); and
  - (2) Clean up spills immediately, using dry clean-up methods where possible, and dispose of used materials properly. You are prohibited from hosing the area down to clean surfaces or spills. Eliminate the source of the spill to prevent a discharge or a furtherance of an ongoing discharge.
- d. **For hazardous or toxic wastes:**<sup>22</sup>
  - (1) Separate hazardous or toxic waste from construction and domestic waste;
  - (2) Store waste in sealed containers, which are constructed of suitable materials to prevent leakage and corrosion, and which are labeled in accordance with applicable Resource

---

<sup>20</sup> Examples of effective means include locating activities away from waters of the state and storm water inlets or conveyances and directing wash waters to a sediment basin or sediment trap, using filtration devices, such as filter bags or sand filters, or using other similarly effective controls.

<sup>21</sup> Examples of building materials and building products typically present at construction sites include asphalt sealants, copper flashing, roofing materials, adhesives, concrete admixtures, and gravel and mulch stockpiles.

<sup>22</sup> Examples of hazardous or toxic waste that may be present at construction sites include paints, caulks, sealants, fluorescent light ballasts, solvents, petroleum-based products, wood preservatives, additives, curing compounds, and acids.



Conservation and Recovery Act (RCRA) requirements and all other applicable federal, state, tribal, or local requirements;

- (3) Store all outside containers within appropriately-sized secondary containment (e.g., spill berms, decks, spill containment pallets) to prevent spills from being discharged, or provide a similarly effective means designed to prevent the discharge of pollutants from these areas (e.g., storing chemicals in a covered area, having a spill kit available on site);
- (4) Dispose of hazardous or toxic waste in accordance with the manufacturer's recommended method of disposal and in compliance with federal, state, tribal, and local requirements;
- (5) Clean up spills immediately, using dry clean-up methods, and dispose of used materials properly. You are prohibited from hosing the area down to clean surfaces or spills. Eliminate the source of the spill to prevent a discharge or a furtherance of an ongoing discharge; and
- (6) Follow all other federal, state, tribal, and local requirements regarding hazardous or toxic waste.

e. **For construction and domestic wastes:**<sup>23</sup>

- (1) Provide waste containers (e.g., dumpster, trash receptacle) of sufficient size and number to contain construction and domestic wastes;
- (2) Provide containment or cover for waste that is blowable or that can leach nutrients, metals, pesticides, herbicides, oil, grease, bacteria, or other pollutants;
- (3) On business days, clean up and dispose of waste in designated waste containers; and
- (4) Clean up immediately if containers overflow.

f. **For sanitary waste**, position portable toilets so that they are secure and will not be tipped or knocked over. Locate them away from waters of the state and, when possible, at least 10 feet from any storm water conveyance, inlet, curb and gutter, or conduit to a waterway. If it is not possible to maintain at least 10 feet of separation, evaluate the need for additional controls such as secondary containment, additional surface preparation, or berms and implement as appropriate.

**2.3.4. For washing applicators and containers used for stucco, paint, concrete, form release oils, curing compounds, or other materials:**

- a. Direct wash water into a leak-proof container or leak-proof and lined pit designed so that no overflows can occur due to inadequate sizing or precipitation;
- b. Handle washout or cleanout wastes as follows:
  - (1) Do not dump liquid wastes in storm sewers or waters of the state;
  - (2) Dispose of liquid wastes properly<sup>24</sup>; and

---

<sup>23</sup> Examples of construction and domestic waste include packaging materials, scrap construction materials, masonry products, timber, pipe and electrical cuttings, plastics, styrofoam, concrete, demolition debris; and other trash or building materials.

- (3) Remove and dispose of hardened concrete waste consistent with your handling of other construction wastes in Part 2.3.3; and
- c. Locate any washout or cleanout activities as far away as possible from waters of the state and storm water inlets or conveyances, and, to the extent feasible, determine areas to be used for these activities and conduct such activities only in these areas.

**2.3.5. For the application of fertilizers:**

- a. Apply at a rate and in amounts consistent with manufacturer's specifications, or document in the SWPPP departures from the manufacturer specifications where appropriate in accordance with Part 7.3.5.b.(5)(ix);
- b. Apply at the appropriate time of year for your location, and preferably timed to coincide as closely as possible to the period of maximum vegetation uptake and growth;
- c. Avoid applying before heavy rains that could cause excess nutrients to be discharged;
- d. Never apply to frozen ground;
- e. Never apply to storm water conveyance channels; and
- f. Follow all other federal, state, tribal, and local requirements regarding fertilizer application.

**2.3.6. Emergency Spill Notification Requirements:** Discharges of toxic or hazardous substances from a spill or other release are prohibited (see Part 1.3). Where a leak, spill, or other release containing a hazardous substance or oil in an amount equal to or in excess of a reportable quantity established under either 40 CFR 110, 40 CFR 117, or 40 CFR 302 occurs during a 24-hour period, you must notify the National Response Center (NRC) at (800) 424-8802 in accordance with the requirements of 40 CFR 110, 40 CFR 117, and 40 CFR 302 as soon as you have knowledge of the release. You must also, within seven (7) calendar days of knowledge of the release, provide a description of the release, the circumstances leading to the release, and the date of the release. State, tribal, or local requirements may necessitate additional reporting of spills or discharges to local emergency response, public health, or drinking water supply agencies.

**2.3.7. Construction Dewatering Requirements:** Water or accumulated storm water that is removed from excavations, trenches, foundations, vaults, or other similar points of accumulation must be permitted by UPDES permit UTG070000 (UPDES Construction Dewatering and Hydrostatic Test Permit) in accordance with Part 1.2.5., unless it can be managed on site. An option for on site management is percolation of the water back into the ground (assuming it is uncontaminated).

---

<sup>24</sup> Proper disposal of liquid waste: 1) evaporate the waste and dispose of the residual solids with other solid waste, 2) have a liquid waste hauler for wash water haul it off and dispose of it, 3) settle it and pretreat it if necessary with arrangements to discharge the liquid waste to a treatment plant that has the ability to treat it and dispose of it.

**3. WATER QUALITY-BASED EFFLUENT LIMITATIONS.**

**3.1. GENERAL EFFLUENT LIMITATION TO MEET APPLICABLE WATER QUALITY STANDARDS.**

Discharges must be controlled as necessary to meet applicable water quality standards. DWQ expects that compliance with the conditions in this permit will result in storm water discharges being controlled as necessary to meet applicable water quality standards. If at any time you become aware, or DWQ determines, that discharges are not being controlled as necessary to meet applicable water quality standards, you must take corrective action as required in Parts 5.1 and 5.2, and document the corrective actions as required in Part 5.4.

DWQ may insist that you install additional controls on a site-specific basis, or require you to obtain coverage under an individual permit, if information in your NOI or from other sources indicates that your discharges are not controlled as necessary to meet applicable water quality standards. This includes situations where additional controls are necessary to comply with a wasteload allocation in an EPA-established or approved TMDL.

The NOI process requires that you determine if the watershed that you discharge into is impaired or if it is considered high quality. Only the first surface water you discharge to is used when determining if your discharge enters an impaired or high quality waterbody. For discharges that enter a storm water system prior to discharge, the first water of the state to which you discharge is the waterbody that receives the storm water discharge from the storm sewer system. Please refer to water quality information at <http://mapserv.utah.gov/surfacewaterquality/>

Each of these cases, impaired or high quality, may require an extra effort to maintain water quality standards. An impaired water body can have an approved TMDL (see Part 10 for definitions) or it can be on the list waiting a TMDL study. An EPA-approved TMDL is a water quality standard. If your project is in an area covered by an EPA-approved TMDL that has sediment or nutrients (particularly phosphorus) identified as the pollutant(s) of concern, you must provide an extra effort to prevent sediment from leaving the site. Nutrients are a component in topsoil from natural biotic systems. Nitrogen (a nutrient) is infused into the soil from biotic systems but also at times from the atmosphere during certain weather conditions. Some soils have phosphorus (a nutrient) from geologic formations in addition to biotic sources. Special efforts including site controls and management efforts must be employed for impaired or high quality waters, but especially for areas with TMDLs identifying sediment or nutrients as the pollutants of concern. Your SWPPP must show the special efforts you are taking for sensitive water bodies.

**3.2. DISCHARGE LIMITATIONS FOR SITES DISCHARGING TO SENSITIVE WATERS<sup>25</sup>**

For any portion of the site that discharges to a sediment or nutrient-impaired water or to a water that is identified as impaired or high quality you must comply with the inspection frequency specified in 4.3 and you must comply with the stabilization deadline specified in Part 2.2.14.<sup>26</sup>

---

<sup>25</sup> Your construction site will be considered to discharge to an impaired or high quality water if the first water to which you discharge is an impaired or high quality water for the pollutants contained in the discharge from your site. For discharges that enter a storm sewer system prior to discharge, the first water to which you discharge is the waterbody that receives the storm water discharge from the storm sewer system.



If you discharge to a water that is impaired for a parameter other than sediment or nutrients, you must address that parameter in your SWPPP if that pollutant has a presence in the construction process for your site. If the impaired parameter is naturally occurring in soils, it is assumed that the erosion control BMPs required by this permit will address the concern and it does not need to be addressed in the SWPPP as a pollutant source. You must deploy whatever control mechanisms that's needed to limit the discharge of that pollutant to meet water quality standards. This includes, if requested by DWQ, comparing the load discharged from the site for that pollutant to ensure it does not exceed a wasteload allocation for that pollutant in the applicable TMDL for the watershed.

---

<sup>26</sup> If you qualify for any of the reduced inspection frequencies in Part 4.4, you may conduct inspections in accordance with Part 4.4 for any portion of your site that discharges to a sensitive water.

**4. SITE INSPECTION REQUIREMENTS.**

**4.1. PERSON(S) RESPONSIBLE FOR INSPECTING THE SITE.** The person(s) inspecting your site may be a person on your staff or a third party you hire to conduct such inspections. You are responsible for ensuring that the person who conducts inspections is a “qualified person” and currently certified.

a. A “qualified person” is a person knowledgeable in the principles and practice of erosion and sediment controls and pollution prevention, who possesses the skills to assess conditions at the construction site that could impact storm water quality, and the skills to assess the effectiveness of any storm water controls selected and installed to meet the requirements of this permit, such as but not limited to the following:

- (1) Utah Registered Storm Water Inspector (RSI)
- (2) Certified Professional in Erosion and Sediment Control (CPESC)
- (3) Certified Professional in Storm Water Quality (CPSWQ)
- (4) Certified Erosion, Sediment, and Storm Water Inspector (CESSWI)
- (5) Certified Inspector of Sediment and Erosion Control (CISEC)
- (6) National Institute for Certification in Engineering Technologies, Erosion and Sediment Control, Level 3 (NICET)
- (7) Utah Department of Transportation Environmental Control Supervisor (ECS)

**4.2. FREQUENCY OF INSPECTIONS.**<sup>27</sup> At a minimum, you must conduct a site inspection in accordance with one of the two schedules listed below, unless you are subject to the Part 4.3 site inspection frequency for discharges to sensitive waters or qualify for a Part 4.4 reduction in the inspection frequency:

**4.2.1.** At least once every seven (7) calendar days; or

**4.2.2.** Once every 14 calendar days and within 24 hours of the occurrence of a storm event of 0.50 inches or greater, or the occurrence of runoff from snowmelt sufficient to cause a discharge.<sup>28</sup> To determine if a storm event of 0.50 inches or greater has occurred on your site, you must either keep a properly maintained rain gauge on your site, or obtain the storm event information from a weather station that is representative of your location. For any day of rainfall during normal business hours that measures 0.50 inches or greater, you must record the total rainfall measured for that day in accordance with Part 4.7.1.d.

**4.3. INCREASE IN INSPECTION FREQUENCY FOR SITES DISCHARGING TO SENSITIVE WATERS.** For any portion of the site that discharges to a sediment or nutrient-

---

<sup>27</sup> Inspections are only required during the site’s normal working hours.

<sup>28</sup> “Within 24 hours of the occurrence of a storm event” means that you must conduct an inspection within 24 hours once a storm event has produced 0.50 inches within a 24-hour period, even if the storm event is still continuing. Thus, if you have elected to inspect bi-weekly in accordance with Part 4.2.2 and there is a storm event at your site that continues for multiple days, and each day of the storm produces 0.50 inches or more of rain, you must conduct an inspection within 24 hours of the first day of the storm and within 24 hours after the end of the storm.

impaired water or to a high quality water (see Part 3), instead of the inspection frequency specified in Part 4.2, you must conduct inspections in accordance with the following inspection frequencies:

Once every seven (7) calendar days and within 24 hours of the occurrence of a storm event of 0.50 inches or greater, or the occurrence of runoff from snowmelt sufficient to cause a discharge. To determine if a storm event of 0.50 inches or greater has occurred on your site, you must either keep a properly maintained rain gauge on your site, or obtain the storm event information from a weather station that is representative of your location. For any day of rainfall during normal business hours that measures 0.50 inches or greater, you must record the total rainfall measured for that day in accordance with Part 4.7.1d.

#### 4.4. REDUCTIONS IN INSPECTION FREQUENCY.

##### 4.4.1. STABILIZED AREAS.

- a. **Temporarily Stabilized Areas.** You may reduce the frequency of inspections to twice per month for the first month, no more than 14 calendar days apart, then once per month in any area of your site where the stabilization steps in part 2.2.14.a. have been completed. If construction activity resumes in this portion of the site at a later date, the inspection frequency immediately increases to that required in Parts 4.2 and 4.3, as applicable. You must document the beginning and ending dates of this period in your SWPPP.
- b. **Permanently Stabilized Areas.** Inspections requirements are suspended.
- c. **Exception For “Linear Construction Sites”** (as defined in Part 10) where disturbed portions have undergone final stabilization at the same time active construction continues on others, you may reduce the frequency of inspections to twice per month for the first month, no more than 14 calendar days apart, in any area of your site where the stabilization steps in 2.2.14.a have been completed. After the first month, inspect once more within 24 hours of the occurrence of a storm event of 0.50 inches or greater. If there are no issues or evidence of stabilization problems, you may suspend further inspections. If “wash-out” of stabilization materials and/or sediment is observed, following re-stabilization, inspections must resume at the inspection frequency required in Part 4.4.1.a. Inspections must continue until final stabilization is visually confirmed following a storm event of 0.50 inches or greater.

##### 4.4.2. ARID, SEMI-ARID (as defined in Part 10). For inspection frequencies (shown below) where it is required to inspect after a storm event, to determine if a storm event of 0.50 inches or greater has occurred on your site you must either keep a properly maintained rain gauge on your site or obtain the storm event information from a weather station that is representative of your location.

- a. **Arid Areas:** Inspections are required once a month and within 24 hours of the occurrence of a storm event of 0.50 inches or greater.
- b. **Semi-Arid Areas:** Inspections are the same as in parts 4.2.1 and 4.2.2 except for the seasonally dry times of the year where they go to once a month and within 24 hours of the occurrence of a



storm event of 0.50 inches or greater.<sup>29</sup> Where the inspection frequency changes to once a month the SWPPP must show the reference for the seasonally dry time period.

**4.4.3. Frozen conditions**

- a. If you are suspending construction activities due to frozen conditions, you may temporarily suspend inspections on your site until thawing conditions (as defined in Part 10) begin to occur if:
  - (1) Runoff is unlikely due to continuous frozen conditions that are likely to continue at your site for at least three (3) months based on historic seasonal averages. If unexpected weather conditions (such as above freezing temperatures or rain events) make discharges likely, you must immediately resume your regular inspection frequency as described in Parts 4.2 and 4.3, as applicable;
  - (2) Land disturbances have been suspended; and
  - (3) Disturbed areas of the site have been stabilized, where possible, in accordance with Part 2.2.14.a.
- b. If you are still conducting construction activities during frozen conditions, you may reduce your inspection frequency to once per month if:
  - (1) Runoff is unlikely due to continuous frozen conditions that are likely to continue at your site for at least three (3) months based on historic seasonal averages. If unexpected weather conditions (such as above freezing temperatures or rain events) make discharges likely, you must immediately resume your regular inspection frequency as described in Parts 4.2 and 4.3, as applicable; and
  - (2) Except for areas in which you are actively conducting construction activities, disturbed areas of the site have been stabilized in accordance with Part 2.2.14.a.

You must document the beginning and ending dates of this period in your SWPPP.

**4.5. AREAS THAT MUST BE INSPECTED:** During your site inspection, you must at a minimum inspect the following areas of your site:

- 4.5.1.** All areas that have been cleared, graded, or excavated and that have not yet completed stabilization consistent with Part 2.2.14.a;
- 4.5.2.** All storm water controls (including pollution prevention controls) installed at the site to comply with this permit;<sup>30</sup>
- 4.5.3.** Material, waste, borrow, and equipment storage and maintenance areas that are covered by this permit;
- 4.5.4.** All areas where storm water typically flows within the site, including drainage ways designed to divert, convey, and/or treat storm water;

---

<sup>29</sup> The Seasonally dry period for the semi-arid areas on the Wasatch Front is June, July, and August. For other areas there are a few internet sites where it is possible to look up the annual rainfall for an area.

<sup>30</sup> This includes the requirement to inspect for sediment that has been tracked out from the site onto paved roads, sidewalks, or other paved areas consistent with Part 2.2.4.

- 4.5.5. All points of discharge from the site; and
- 4.5.6. All locations where stabilization measures have been implemented.
- 4.5.7. You are not required to inspect areas that, at the time of the inspection, are considered unsafe to your inspection personnel.
- 4.6. **REQUIREMENTS FOR INSPECTIONS;** During your site inspection, you must at a minimum:
  - 4.6.1. Check whether all storm water controls (i.e., erosion and sediment controls and pollution prevention controls) are properly installed, appear to be operational, and are working as intended to minimize pollutant discharges. Consider what has caused a BMP's failure if it is not operational;
  - 4.6.2. Check for the presence of conditions that could lead to spills, leaks, or other accumulations of pollutants on the site;
  - 4.6.3. Identify any locations where new or modified storm water controls are necessary to meet the requirements of Parts 2 and/or 3;
  - 4.6.4. Check for signs of visible erosion and sedimentation (i.e., sediment deposits) that have occurred and are attributable to your discharge at points of discharge and, if applicable, the banks of any waters of the state flowing within or immediately adjacent to the site;
  - 4.6.5. Identify any incidents of noncompliance observed;
  - 4.6.6. If a discharge is occurring during your inspection:
    - a. Identify all discharge points at the site; and
    - b. Observe and document the visual quality of the discharge, and take note of the characteristics of the storm water discharge, including color; odor; floating, settled, or suspended solids; foam; oil sheen; and other indicators of storm water pollutants.
  - 4.6.7. Based on the results of your inspection, complete any necessary maintenance under Part 2.1.4 and corrective action under Part 5.
- 4.7. **INSPECTION REPORT**<sup>31</sup>
  - 4.7.1. You must complete an inspection report within 24 hours of completing any site inspection. Each inspection report must include the following:
    - a. The inspection date;
    - b. The UPDES CGP permit tracking number;
    - c. Names and titles of personnel making the inspection;
    - d. A summary of your inspection findings, covering at a minimum the observations you made in accordance with Part 4.6, including any necessary maintenance or corrective actions;
    - e. If you are inspecting your site at the frequency specified in Part 4.2.2, Part 4.3, Part 4.4.1.c, Part 4.4.2.a, or Part 4.4.2.b and you conducted an inspection because of rainfall measuring 0.50

---

<sup>31</sup> See DWQ construction storm water web page for ideas and examples of self-inspection forms.

inches or greater, you must include the applicable rain gauge or weather station readings that triggered the inspection; and

- f. If you determined that it is unsafe to inspect a portion of your site, you must describe the reason you found it to be unsafe and specify the locations to which this condition applies.
- 4.7.2. Each inspection report must be signed in accordance with 9.16(1)b. of this permit.
- 4.7.3. You must keep a copy, in paper or electronic form, of all inspection reports at the site or at an easily accessible location, so that it can be made available at the time of an on-site inspection or upon request by DWQ, a local municipality of jurisdiction, or by the EPA.
- 4.7.4. You must retain all inspection reports completed for this Part for at least three (3) years from the date that your permit coverage expires or is terminated.
- 4.8. **INSPECTIONS BY DWQ MS4 OR EPA:** You must allow an authorized representative of DWQ, the MS4 of jurisdiction or the EPA to conduct the following activities at reasonable times. To the extent that you are utilizing shared controls that are not on site to comply with this permit, you must make arrangements for DWQ to have access at all reasonable times to those areas where the shared controls are located.
  - 4.8.1. Enter onto all areas of the site, including any construction support activity areas covered by this permit, any off-site areas where shared controls are utilized to comply with this permit, discharge locations, adjoining waterbodies, and locations where records are kept under the conditions of this permit;
  - 4.8.2. Access and copy any records that must be kept under the conditions of this permit;
  - 4.8.3. Inspect your construction site, including any construction support activity areas covered by this permit (see Part 1.2.2), any storm water controls installed and maintained at the site, and any off-site shared controls utilized to comply with this permit; and
  - 4.8.4. Sample or monitor for the purpose of ensuring compliance.



## 5. CORRECTIVE ACTIONS

**5.1. CONDITIONS TRIGGERING CORRECTIVE ACTION:** You must take corrective action to address any of the following conditions identified at your site:

- 5.1.1. A storm water control needs repair or replacement (beyond routine maintenance required under Part 2.1.4); or
- 5.1.2. A storm water control necessary to comply with the requirements of this permit was never installed, or was installed incorrectly; or
- 5.1.3. Your discharges are causing an exceedance of applicable water quality standards; or
- 5.1.4. A prohibited discharge has occurred (see Part 1.3).

**5.2. CORRECTIVE ACTION DEADLINES:** For any corrective action triggering conditions in Part 5.1, you must:

- 5.2.1. When site conditions warrant immediate attention, take all reasonable steps to minimize or prevent the discharge of pollutants until a permanent solution for the problem is installed and made operational;
- 5.2.2. When the problem does not require a new or replacement control or significant repair, the corrective action must be completed by the close of the next business day;
- 5.2.3. When the problem requires a new or replacement control or significant repair, the corrective action must be completed no later than seven (7) calendar days from the time of discovery. If it is infeasible to complete the installation or repair within seven (7) calendar days (e.g., due to availability of materials, excessive costs to expedite shipping or activities, or lengthy installation times) you must document in your records why it is infeasible and provide a reasonable correction schedule.

**5.3. CORRECTIVE ACTION REQUIRED BY DWQ:** You must comply with any corrective actions required by DWQ as a result of permit violations found during an inspection carried out under Part 4.8.

**5.4. CORRECTIVE ACTION REPORT:** For each corrective action taken in accordance with this Part, you must complete a report in accordance with the following:

- 5.4.1. Within 24 hours of identifying the corrective action condition, document the specific condition and the date and time it was identified.
- 5.4.2. Within 24 hours of the observed completion of a corrective action and in accordance with the deadlines in Part 5.2, document the actions taken to address the condition, including the date and whether any SWPPP modifications are required.
- 5.4.3. Where these actions result in changes to any of the storm water controls or procedures documented in your SWPPP, you must modify your SWPPP (and SWPPP map) accordingly within seven (7) calendar days of completing this work.
- 5.4.4. You must keep a copy of all corrective action reports at the site or at an easily accessible location, so that it can be made available at the time of an on-site inspection or upon request by

DWQ. Corrective action reports may be maintained and made available in paper or electronically.

- 5.4.5.** You must retain all corrective action reports completed for this Part for at least three (3) years from the date that your permit coverage expires or is terminated.

## 6. STAFF TRAINING REQUIREMENTS

Each operator, or group of multiple operators, must assemble a “storm water team” to carry out compliance activities associated with the requirements in this permit.

- 6.1. PRIOR TO THE COMMENCEMENT OF CONSTRUCTION ACTIVITIES**, you must ensure that the following personnel<sup>32</sup> on the storm water team understand the requirements of this permit and their specific responsibilities with respect to those requirements:
- 6.1.1.** Personnel who are responsible for the design, installation, maintenance, and/or repair of storm water controls (including pollution prevention controls);
  - 6.1.2.** Personnel responsible for the application and storage of treatment chemicals (if applicable);
  - 6.1.3.** Personnel who are responsible for conducting inspections as required in Part 4.1; and
  - 6.1.4.** Personnel who are responsible for taking corrective actions as required in Part 5.
- 6.2. YOU ARE RESPONSIBLE FOR ENSURING THAT ALL ACTIVITIES ON THE SITE COMPLY** with the requirements of this permit. You are not required to provide formal training for subcontractors or other outside service providers, but you must ensure that such personnel understand any requirements of this permit that may be affected by the work they are subcontracted to perform. You should document that you have explained or have given subcontractors information about how to perform their work in compliance with the SWPPP.
- 6.3. AT A MINIMUM, MEMBERS OF THE STORM WATER TEAM MUST BE TRAINED** to understand the following if related to the scope of their job duties (e.g., only personnel responsible for conducting inspections need to understand how to conduct inspections):
- 6.3.1.** The permit deadlines associated with installation, maintenance, and removal of storm water controls and with stabilization;
  - 6.3.2.** The location of all storm water controls on the site required by this permit and how they are to be maintained;
  - 6.3.3.** The proper procedures to follow with respect to the permit’s pollution prevention requirements; and
  - 6.3.4.** When and how to conduct inspections, record applicable findings, and take corrective actions.
- 6.4. EACH MEMBER OF THE STORM WATER TEAM MUST HAVE EASY ACCESS TO AN ELECTRONIC OR PAPER COPY** of applicable portions of this permit, the most updated copy of your SWPPP, and other relevant documents or information that must be kept with the SWPPP.

---

<sup>32</sup> If the person requiring training is a new employee who starts after you commence construction activities, you must ensure that this person has the proper understanding as required above prior to assuming particular responsibilities related to compliance with this permit.



## 7. STORM WATER POLLUTION PREVENTION PLAN (SWPPP)

### 7.1. GENERAL REQUIREMENTS

All operators associated with a construction site under this permit must develop a SWPPP consistent with the requirements in Part 7 prior to their submittal of the NOI.<sup>33</sup> The SWPPP must be kept up-to-date throughout coverage under this permit.

If a SWPPP was prepared under a previous version of this permit, the operator must review and update the SWPPP to ensure that this permit's requirements are addressed prior to submitting an NOI for coverage under this permit.

**7.2. SWPPP WRITER/REVIEWER CERTIFICATION REQUIREMENT** Beginning January 1, 2021, a "qualified" SWPPP writer must write or certify SWPPPs for all projects disturbing greater than 5 acres, including small construction projects (1 to 5 acres) that have a perennial surface water within 50 feet of the project, or having a steep slope (70% or 35 degrees or more) with an elevation change from the slope of 10 feet or more (at any point during the time of construction – not including stock piles). A "qualified" SWPPP writer is knowledgeable in the principles and practices that must be considered in the development of a SWPPP. Acceptable qualifications include but are not limited to:

- a. Utah Registered SWPPP Writer (RSW)
- b. Licensed Professional Engineer (PE) in a related field or Professional Geologist (PG)
- c. Certified Professional in Erosion and Sediment Control (CPESC)
- d. Certified Professional in Storm Water Quality (CPSWQ)
- e. National Institute for Certification in Engineering Technologies, Erosion and Sediment Control, Level 3 (NICET)

**7.3. SWPPP CONTENTS.** At a minimum, the SWPPP must include the information specified in this Part and as specified in other parts of this permit.

**7.3.1. Storm Water Team.** Identify the personnel (by name or position) that are part of the storm water team, as well as their individual responsibilities, including which members are responsible for conducting inspections.

**7.3.2. Nature of Construction Activities.**<sup>34</sup> Include the following:

- a. A description of the nature of your construction activities, including the age or dates of past renovations for structures that are undergoing demolition;
- b. The size of the property (in acres or length in miles if a linear construction site);

---

<sup>33</sup> The SWPPP does not establish the effluent limits that apply to your site's discharges; these limits are established in this permit in Parts 2 and 3.

<sup>34</sup> If plans change due to unforeseen circumstances or for other reasons, the requirement to describe the sequence and estimated dates of construction activities is not meant to "lock in" the operator to meeting these dates. When departures from initial projections are necessary, this should be documented in the SWPPP itself, or in associated records, as appropriate.

- c. The total area expected to be disturbed by the construction activities including on-site and off-site construction support activity areas (to the nearest quarter acre or nearest quarter mile if a linear construction site);
- d. A description of any on-site and off-site construction support activity areas covered by this permit (see Part 1.2.2);
- e. A description and projected schedule for the following:
  - (1) Commencement of construction activities in each portion of the site, including clearing and grubbing, mass grading, demolition activities, site preparation (i.e., excavating, cutting and filling), final grading, and creation of soil and vegetation stockpiles requiring stabilization;
  - (2) Temporary or permanent cessation of construction activities in each portion of the site;
  - (3) Temporary or final stabilization of exposed areas for each portion of the site; and
  - (4) Removal of temporary storm water controls and construction equipment or vehicles, and the cessation of construction-related pollutant-generating activities.
- f. A list and description of all pollutant-generating activities<sup>35</sup> on the site. For each pollutant-generating activity, include an inventory of pollutants or pollutant constituents (e.g., sediment, fertilizers, pesticides, paints, caulks, sealants, fluorescent light ballasts, contaminated substrates, solvents, fuels) associated with that activity, which could be discharged in storm water from your construction site. You must take into account where potential spills and leaks could occur that contribute pollutants to storm water discharges, and any known hazardous or toxic substances, such as PCBs and asbestos, that will be disturbed or removed during construction;
- g. Business days and hours for the project;

**7.3.3. Site Map.** Include a legible map, or series of maps, showing the following features of the site:

- a. Boundaries of the property;
- b. Locations where construction activities will occur, including:
  - (1) Locations where earth-disturbing activities will occur (note any phasing), including any demolition activities;
  - (2) Approximate slopes before and after major grading activities (note any steep slopes (as defined in Part 10));
  - (3) Locations where sediment, soil, or other construction materials will be stockpiled;
  - (4) Any water of the state crossings;
  - (5) Designated points where vehicles will exit onto paved roads;
  - (6) Locations of structures and other impervious surfaces upon completion of construction; and
  - (7) Locations of on-site and off-site construction support activity areas covered by this permit (see Part 1.2.2).

---

<sup>35</sup> Examples of pollutant-generating activities include paving operations; concrete, paint, and stucco washout and waste disposal; solid waste storage and disposal; and dewatering operations

- c. Locations of all waters of the state within one mile downstream of the site's discharge point. Also identify if any are listed as impaired or high quality water;
- d. Type and extent of pre-construction cover on the site (e.g., vegetative cover, forest, pasture, pavement, structures);
- e. Drainage patterns of storm water and authorized non-storm water before and after major grading activities;
- f. Storm water and authorized non-storm water discharge locations, including:
  - (1) Locations where storm water and/or authorized non-storm water will be discharged to storm drain inlets;<sup>36</sup> and
  - (2) Locations where storm water or authorized non-storm water will be discharged directly to waters of the state.
- g. Locations of all potential pollutant-generating activities identified in Part 7.3.2.g;
- h. Locations of storm water controls, including natural buffer areas and any shared controls utilized to comply with this permit; and
- i. Locations where polymers, flocculants, or other treatment chemicals will be used and stored.

**7.3.4. Non-Storm water Discharges.** Identify all authorized non-storm water discharges in Part 1.2.3 that will or may occur.

**7.3.5. Description of Storm water Controls.**

- a. For each of the Part 2.2 erosion and sediment control effluent limits, Part 2.3 pollution prevention effluent limits as applicable to your site, you must include the following:
  - (1) A description of the specific control(s) to be implemented to meet the effluent limit;
  - (2) Any applicable storm water control design specifications (including references to any manufacturer specifications and/or erosion and sediment control manuals/ordinances relied upon);<sup>37</sup>
  - (3) Routine storm water control maintenance specifications; and
  - (4) The projected schedule for storm water control installation/implementation.
- b. You must also include any of the following additional information as applicable.
  - (1) **Natural buffers** and/or equivalent sediment controls (see Part 2.2.1 and Part 10). You must include the following:
    - (i) The compliance alternative to be implemented;

---

<sup>36</sup> The requirement to show storm drain inlets in the immediate vicinity of the site on your site map only applies to those inlets that are easily identifiable from your site or from a publicly accessible area immediately adjacent to your site.

<sup>37</sup> Design specifications may be found in manufacturer specifications and/or in applicable erosion and sediment control manuals or ordinances. Any departures from such specifications must reflect good engineering practice and must be explained in the SWPPP.



- (ii) If complying with alternative 2, the width of natural buffer retained;
  - (iii) If complying with alternative 2 or 3, the erosion and sediment control(s) you will use to achieve an equivalent sediment reduction, and any information you relied upon to demonstrate the equivalency;
  - (iv) If complying with alternative 3, a description of why it is infeasible for you to provide and maintain an undisturbed natural buffer of any size;
  - (v) For “linear construction sites” where it is infeasible to implement compliance alternative 1, 2, or 3, a rationale for this determination, and a description of any buffer width retained and/or supplemental erosion and sediment controls installed; and
  - (vi) A description of any disturbances that are exempt under Part 2.2.1 that occur within 50 feet of a water of the state.
- (2) **Perimeter controls for a “linear construction site”** (see Part 2.2.3). For areas where perimeter controls are not feasible, include documentation to support this determination and a description of the other practices that will be implemented to minimize discharges of pollutants in storm water associated with construction activities.

Note: Routine maintenance specifications for perimeter controls documented in the SWPPP must include the Part 2.2.3.a requirement that sediment be removed before it has accumulated to one-half of the above-ground height of any perimeter control.

- (3) **Sediment track-out controls** (see Parts 2.2.4.b and 2.2.4.c). Document the specific stabilization techniques and/or controls that will be implemented to remove sediment prior to vehicle exit.
- (4) **Sediment basins** (see Part 2.2.12). In circumstances where it is infeasible to utilize outlet structures that withdraw water from the surface, include documentation to support this determination, including the specific conditions or time periods when this exception will apply.
- (5) **Treatment chemicals** (see Part 2.2.13), you must include the following:
- (i) A listing of the soil types that are expected to be exposed during construction in areas of the project that will drain to chemical treatment systems. Also include a listing of soil types expected to be found in fill material to be used in these same areas, to the extent you have this information prior to construction;
  - (ii) A listing of all treatment chemicals to be used at the site and why the selection of these chemicals is suited to the soil characteristics of your site;
  - (iii) If DWQ authorized you to use cationic treatment chemicals for sediment control, include the specific controls and implementation procedures designed to ensure that your use of cationic treatment chemicals will not lead to an exceedance of water quality standards, or harm to aquatic life;
  - (iv) The dosage of all treatment chemicals to be used at the site or the methodology to be used to determine dosage;

- (v) Information from any applicable Safety Data Sheet (SDS);
  - (vi) Schematic drawings of any chemically enhanced storm water controls or chemical treatment systems to be used for application of the treatment chemicals;
  - (vii) A description of how chemicals will be stored consistent with Part 2.2.13.c;
  - (viii) References to applicable local requirements affecting the use of treatment chemicals, and copies of applicable manufacturer's specifications regarding the use of your specific treatment chemicals and/or chemical treatment systems; and
  - (ix) A description of the training that personnel who handle and apply chemicals have received prior to permit coverage, or will receive prior to use of the treatment chemicals at your site.
- (6) **Stabilization measures** (see Part 2.2.14). You must include the following:
- (i) The specific vegetative and/or non-vegetative practices that will be used;
  - (ii) The stabilization deadline that will be met in accordance with Part 2.2.14.a(1)-(2);
  - (iii) It is important to meet the deadlines during the wet times of the year (if the area has a wet time of the year). During the dry times of the year the significance of stabilization deadlines is less important.
- (7) **Spill prevention and response procedures** (see Part 1.3.5 and Part 2.3). You must include the following:
- (i) Procedures for expeditiously stopping, containing, and cleaning up spills, leaks, and other releases. Identify the name or position of the employee(s) responsible for detection and response of spills or leaks; and
  - (ii) Procedures for notification of appropriate facility personnel, emergency response agencies, and regulatory agencies where a leak, spill, or other release containing a hazardous substance or oil in an amount equal to or in excess of a reportable quantity consistent with Part 2.3.6 and established under either 40 CFR 110, 40 CFR 117, or 40 CFR 302, occurs during a 24-hour period. Contact information must be in locations that are readily accessible and available to all employees.
  - (iii) You may also reference the existence of Spill Prevention Control and Countermeasure (SPCC) plans developed for the construction activity under Part 311 of the CWA, or spill control programs otherwise required by an UPDES permit for the construction activity, provided that you keep a copy of that other plan on site or electronically available.<sup>38</sup>
- (8) **Waste management procedures** (see Part 2.3.3). Describe the procedures you will follow for handling, storing and disposing of all wastes generated at your site consistent with state and local requirements, including clearing and demolition debris, removal of spoil (excess dirt) from the site, construction and domestic waste, hazardous or toxic waste, and sanitary waste.

---

<sup>38</sup> Even if you already have an SPCC or other spill prevention plan in existence, your plans will only be considered adequate if they meet all of the requirements of this Part, either as part of your existing plan or supplemented as part of the SWPPP

- (9) **Application of fertilizers** (see Part 2.3.5). Document any departures from the manufacturer specifications where appropriate.

**7.3.6. Procedures for Inspection, Maintenance, and Corrective Action.** Describe the procedures you will follow for maintaining your storm water controls, conducting site inspections, and, where necessary, taking corrective actions, in accordance with Part 2.1.4, Part 4, and Part 5 of this permit. Also include:

- a. Personnel responsible for conducting inspections;
- b. The inspection schedule you will follow, which is based on whether your site is subject to Part 4.2 or Part 4.3, or whether your site qualifies for any of the reduced inspection frequencies in Part 4.4;
- c. If you will be conducting inspections in accordance with the inspection schedule in Part 4.2.2, or Part 4.3, the location of the rain gauge or the address of the weather station you will be using to obtain rainfall data;
- d. If you will be reducing your inspection frequency in accordance with Part 4.4.3, the beginning and ending dates of frozen conditions on your site; and
- e. Any maintenance or inspection checklists or other forms that will be used.

**7.3.7. Staff Training.** Include documentation that the required personnel were, or will be, trained in accordance with Part 6.

**7.3.8. Compliance with Other Requirements.**

- a. **Utah Water Quality Act Underground Injection Control (UIC) Program Requirements for Certain Subsurface Storm Water Controls.** If you are using any of the following storm water controls at your site, as they are described below, you must document any contact you have had with DWQ for implementing the requirements for underground injection wells in the Safe Drinking Water Act and DEQ's implementing regulations at UAC R317-7. In addition there may be local requirements related to such structures. Such controls (below) would generally be considered Class V UIC wells and all Class V UIC wells must be reported to DWQ for an inventory:
  - b. Infiltration trenches (if storm water is directed to any bored, drilled, driven shaft or dug hole that is deeper than its widest surface dimension, or has a subsurface fluid distribution system);
  - c. Commercially manufactured pre-cast or pre-built proprietary subsurface detention vaults, chambers, or other devices designed to capture and infiltrate storm water flow; and
  - d. Drywells, seepage pits, or improved sinkholes (if storm water is directed to any bored, drilled, driven shaft or dug hole that is deeper than its widest surface dimension, or has a subsurface fluid distribution system).

**7.3.9. SWPPP Certification.** You must sign and date your SWPPP in accordance with 9.16(1)a.

**7.3.10. Post-Authorization Additions to the SWPPP.** Once you are authorized for coverage under this permit, you must include the following documents as part of your SWPPP:



- a. A copy of your NOI submitted to DWQ along with any correspondence exchanged between you and DWQ related to coverage under this permit;
- b. A copy of this permit (an electronic copy easily available to the storm water team is also acceptable).

**7.4. ON-SITE AVAILABILITY OF YOUR SWPPP**

**7.4.1.** You must keep a current copy of your SWPPP at the site or at an easily accessible location so that it can be made available at the time of an on-site inspection or upon request by DWQ, the EPA, or an MS4. The SWPPP can be stored electronically as long as personnel on-site can access it and make it available for inspector review.

**7.5. SWPPP MODIFICATIONS.**

**7.5.1.** You must modify your SWPPP, including the site map(s), within seven (7) days of any of the following conditions:

- a. Whenever you make changes to your construction plans, storm water controls, or other activities at your site that are no longer accurately reflected in your SWPPP. This includes changes made in response to corrective actions triggered under Part 5. You do not need to modify your SWPPP if the estimated dates in Part 7.3.2.f change during the course of construction;
- b. To reflect areas on your site map where operational control has been transferred (e.g., new general contractor or owner), note the change and the date of transfer since initiating permit coverage;
- c. If inspections or investigations by DWQ or its authorized representatives determine that SWPPP modifications are necessary for compliance with this permit;
- d. Where DWQ determines it is necessary to install and/or implement additional controls at your site in order to meet the requirements of this permit, the following must be included in your SWPPP:
  - (1) A copy of any correspondence describing such measures and requirements; and
  - (2) A description of the controls that will be used to meet such requirements.
- e. To reflect any revisions to applicable federal, state, tribal, or local requirements that affect the storm water controls implemented at the site; and
- f. If applicable, if a change in chemical treatment systems or chemically enhanced storm water control is made, including use of a different treatment chemical, different dosage rate, or different area of application.

**7.5.2.** You must maintain records showing the dates of all SWPPP modifications. The records must include the name of the person authorizing each change (see Part 7.5.1 above) and a brief summary of all changes.

**7.5.3.** All modifications made to the SWPPP consistent with Part 7.5 must be authorized by a person identified in 9.16.(1)b.

**7.5.4.** Upon determining that a modification to your SWPPP is required, you must notify any persons or subcontractors that may be impacted by the change to the SWPPP.

**8. HOW TO TERMINATE COVERAGE.** Until you terminate coverage under this permit, you must comply with all conditions and effluent limitations in the permit. To terminate permit coverage, you must submit to DWQ a complete and accurate Notice of Termination (NOT, the NOT can be done online in the same account that the NOI was taken out in), which certifies that you have met the requirements for terminating in Part 8.

**8.1. MINIMUM INFORMATION REQUIRED IN NOT.**

**8.1.1.** UPDES ID (i.e., permit tracking number) provided by DWQ when you received coverage under this permit;

**8.1.2.** Basis for submission of the NOT (see Part 8.2);

**8.1.3.** Operator contact information;

**8.1.4.** Name of site and address (or a description of location if no street address is available); and

**8.1.5.** NOT certification.

**8.2. CONDITIONS FOR TERMINATING CGP COVERAGE.** You must terminate CGP coverage only if one or more of the following conditions has occurred:

**8.2.1.** You have completed all construction activities at your site and, if applicable, construction support activities covered by this permit (see Part 1.2.2.c), and you have met the following requirements:

- a. You have met the requirements for final vegetative or non-vegetative stabilization in Part 2.2.14.b for any areas that (1) were disturbed during construction, (2) are not covered over by permanent structures, and (3) over which you had control during the construction activities.;
- b. You have removed and properly disposed of all construction materials, waste and waste handling devices, and have removed all equipment and vehicles that were used during construction, unless intended for long-term use following your termination of permit coverage;
- c. You have removed all storm water controls that were installed and maintained during construction, except those that are intended for long-term use following your termination of permit coverage or those that are biodegradable; and
- d. You have removed all potential pollutants and pollutant-generating activities associated with construction, unless needed for long-term use following your termination of permit coverage; or

**8.2.2.** You have transferred control of all areas of the site for which you are responsible under this permit to another operator, and that operator has submitted a new NOI and obtained coverage under this permit. This only applies if the new operator obtains a new NOI. Termination is not required if a transfer form has been signed by both the previous operator and the new one to move the existing coverage; or

**8.2.3.** Coverage under an individual or alternative general UPDES permit has been obtained.

**8.2.4.** Completed homes that are occupied by home owners where at least temporary sediment and erosion controls are in place are allowed to be terminated without final stabilization. If a home owner buys a newly completed house the permit can be terminated while the property is being transferred to the home owner. The home owner should not be involved in the permit process. If

a home owner builds his/her house, they must terminate when the house is approved for occupancy where temporary storm water controls are in place on the site.

**8.3. HOW TO SUBMIT YOUR NOT.**

**8.3.1.** It is preferred that the DWQ “on-line” NOI system be used to submit an electronic NOT.

Access to the DWQ online storm water database found at the DWQ webpage at <https://secure.utah.gov/stormwater>. You must logon to the account created when the NOI was submitted and find the “Terminate” (or NOT) button for the permit tracking number when you wish to terminate a coverage. In the case where the permittee does not have access to the account for which the NOI was submitted the permittee must either contact DWQ and request account access or fill out and submit to DWQ a paper copy of the NOT form, which can be downloaded from the same DWQ website.

**8.4. DEADLINE FOR SUBMITTING THE NOT.** You must submit your NOT within 30 calendar days after any one of the conditions in Part 8.2 occurs.

**8.5. PARTIAL NOT REQUIREMENTS.** A partial NOT must be filed if a portion of the permitted site is sold to a new owner prior to completion of construction. You must notify the new owner of the requirement to obtain a storm water permit unless the new owner is the home owner. Prior to releasing a residential lot to a home owner the site must be temporarily stabilized as required in 8.2.4. You must notify DWQ of the change in ownership and provide the name, address, and telephone number of the new owner.

**8.6. EFFECTIVE DATE OF TERMINATION OF COVERAGE.** Your authorization to discharge under this permit terminates at midnight of the calendar day that a complete NOT is submitted to DWQ.



**9. STANDARD PERMIT CONDITIONS.**

**9.1. DUTY TO COMPLY.**

- (1) The permittee must comply with all conditions of the UPDES permit. Any permit noncompliance is a violation of the Utah Water Quality Act, as amended and is grounds for enforcement action; permit termination, revocation and reissuance or modification; or denial of a permit renewal application.
- (2) Penalties for Violations of Permit Conditions. The Utah Water Quality Act, in 19-5-115, provides that any person who violates the Act, or any permit, rule, or order adopted under it is subject to a civil penalty not to exceed \$10,000 per day of such violation.
- (3) Willful Non-Compliance or Negligence. Any person who willfully or with gross negligence violates the Act, or any permit, rule or order adopted under it is subject to a fine of not more than \$25,000 per day of violation. Any person convicted under 19-5-115 a second time shall be punished by a fine not exceeding \$50,000 per day.
- (4) False Statements. The Act provides that any person who knowingly makes any false material statement, representation, or certification in any application, record, report, plan, or other document filed or required to be maintained under the Act, the rules, or this Permit, or who knowingly falsifies, tampers with, or renders inaccurate, any monitoring device or method required to be maintained under the Act shall upon conviction, be punished by a fine of not more than \$10,000 or by imprisonment for 6 months, or by both. Utah Code Ann. § 19-5-115(4).

**9.2. DUTY TO REAPPLY.** If the permittee wishes to continue an activity regulated by this permit after the expiration date of the permit, the permittee shall apply for and obtain a new permit as required in R317-8-3.1

**9.3. NEED TO HALT OR REDUCE ACTIVITY NOT A DEFENSE.** It shall not be a defense for a permittee in an enforcement action that it would have been necessary to halt or reduce the permitted activity in order to maintain compliance with the conditions of this permit. (Upon reduction, loss, or failure of the treatment facility, the permittee, to the extent necessary to maintain compliance with the permit, shall control production of all discharges until the facility is restored or an alternative method of treatment is provided.)

**9.4. DUTY TO MITIGATE.** The permittee shall take all reasonable steps to minimize or prevent any discharge or sludge use or disposal in violation of the UPDES permit which has a reasonable likelihood of adversely affecting human health or the environment.

**9.5. DUTY TO PROVIDE INFORMATION.** The permittee shall furnish to the Director, within a reasonable time, any information which the Director may request to determine whether cause exists for modifying, revoking and reissuing, or terminating the permit or to determine compliance with this permit. The permittee shall also furnish to the Director, upon request, copies of records required to be kept by the permit.

**9.6. OTHER INFORMATION.** When the permittee becomes aware that he or she failed to submit any relevant facts or submitted incorrect information in the Notice of Intent or in any other report to the Director, he or she shall promptly submit such facts or information.

**9.7. OIL AND HAZARDOUS SUBSTANCE LIABILITY.** Nothing in this Permit shall be construed to preclude the institution of any legal action or relieve the Permittee from any responsibilities, liabilities, or penalties to which the Permittee is or may be subject under the "Act".

**9.8. PROPERTY RIGHTS.** The issuance of this Permit does not convey any property rights of any sort, nor any exclusive privileges, nor does it authorize any injury to private property nor any invasion of personal rights, nor any infringement of Federal, State or local laws or regulations.

**9.9. SEVERABILITY.** The provisions of this Permit are severable, and if any provision of this Permit, or the application of any provision of this Permit to any circumstance, is held invalid, the application of such provision to other circumstances, and the remainder of this Permit shall not be affected thereby.

**9.10. RECORDS RETENTION.**

- (1) The Permittee shall retain copies of SWPPPs and all reports required by this Permit, and records of all data used to complete the Notice of Intent to be covered by this Permit, for a period of at least three years from the date that the site is finally stabilized. This period may be extended by request of the Director at any time.
- (2) After final stabilization of the construction site is complete, the SWPPP is no longer required to be maintained on site, but may be maintained by the Permittee(s) at its primary headquarters. However, you must continue to allow DWQ access to the SWPPP as described in paragraph B.10(1) (above).

**9.11. ADDRESSES.** All written correspondence under this permit shall be directed to the Division of Water Quality at the following address:

Department of Environmental Quality  
Division of Water Quality  
195 North 1950 West  
PO Box 144870  
Salt Lake City, Utah 84114-4870

**9.12. STATE LAWS.**

- (1) Nothing in this Permit shall be construed to preclude the institution of any legal action or relieve the Permittee from any responsibilities, liabilities, or penalties established pursuant to any applicable State law or regulation under authority preserved by Utah Code Ann. § 19-5-117.
- (2) No condition of this Permit shall release the Permittee from any responsibility or requirements under other environmental statutes or regulations.

**9.13. PROPER OPERATION AND MAINTENANCE.** The Permittee shall at all times properly operate and maintain all facilities and systems of treatment and control (and related appurtenances) which are installed or used by the Permittee to achieve compliance with the conditions of this Permit and with the requirements of SWPPPs. Proper operation and maintenance also includes adequate laboratory controls and appropriate quality assurance procedures. Proper operation and maintenance requires the operation of backup or auxiliary

facilities or similar systems, installed by a Permittee only when necessary to achieve compliance with the conditions of the Permit.

**9.14. INSPECTION AND ENTRY.** The Permittee shall allow, upon presentation of credentials, the Director or an authorized representative:

- (1) To enter upon the Permittee's premises where a regulated facility or activity is located or conducted, or where records must be kept under the conditions of this Permit;
- (2) Have access to and copy at reasonable times, any records that must be kept under the conditions of this Permit;
- (3) Inspect at reasonable times any facilities, equipment (including monitoring and control equipment), practices, or operations regulated or required under this Permit; and
- (4) Sample or monitor at reasonable times, for the purposes of assuring permit compliance or as otherwise authorized by law, any substances or parameters at any location.

**9.15. REOPENER CLAUSE.**

- (1) Reopener Due to Water Quality Impacts. If there is evidence indicating that the storm water discharges authorized by this Permit cause, have the reasonable potential to cause or contribute to, a violation of a water quality standard, the discharger may be required to obtain an individual permit or an alternative general permit in accordance with Part 1.4.4 of this Permit or the Permit may be modified to include different limitations and/or requirements.
- (2) Reopener Guidelines. Permit modification or revocation will be conducted according to UAC R317-8-5.6 and UAC R317-8-6.2.
- (3) Permit Actions. This Permit may be modified, revoked and reissued, or terminated for cause. The filing of a request by the Permittee for a Permit modification, revocation and reissuance, or termination, or a notification of planned changes or anticipated noncompliance does not stay any Permit condition.

**9.16. SIGNATORY REQUIREMENTS.**

- (1) All Notices of Intent, SWPPPs, reports, certifications or information submitted to the Director, or that this Permit requires to be maintained by the Permittee, shall be signed as follows:
  - a. All notice of intent (NOIs), notices of termination (NOTs), and SWPPPs shall be signed as follows:
    - i. For a corporation: by a responsible corporate officer. For the purpose of this section, a responsible corporate officer means: a president, secretary, treasurer, or vice-president of the corporation in charge of a principal business function, or any other person who performs similar policy or decision-making functions for the corporation; or the manager of one or more manufacturing, production or operating facilities employing more than 250 persons or having gross annual sales or expenditures exceeding \$25,000,000 (in second-quarter 1980 dollars) if authority to sign documents has been assigned or delegated to the manager in accordance with corporate procedures;



- ii. For a partnership of sole proprietorship: by a general partner or the proprietor, respectively; or
- iii. For a municipality, State, Federal, or other public agency: by either a principal executive officer or ranking elected official. For purposes of this section, a principal executive officer of a Federal agency includes (1) the chief executive officer of the agency, or (2) a senior executive officer having responsibility for the overall operations of a principal geographic unit of the agency (e.g. Regional Administrators of EPA).
- b. All reports required by the Permit and other information requested by the Director or by an authorized representative of the Director shall be signed by a person described above or by a duly authorized representative of that person. A person is a duly authorized representative only if:
  - i. The authorization is made in writing by a person described above and kept with the SWPPP; and
  - ii. The authorization specifies either an individual or a position having responsibility for overall operation of the regulated site, facility or activity, such as the position of manager, operator, superintendent, or position of equivalent responsibility or an individual or position having overall responsibility for environmental matters for the company. (A duly authorized representative may thus be either a named individual or any individual occupying a named position).
- c. Certification. Any person signing documents under this Part B.16 shall make the following certification:

I certify under penalty of law that this document and all attachments were prepared under my direction or supervision in accordance with a system designed to assure that qualified personnel properly gathered and evaluated the information submitted. Based on my inquiry of the person or persons who manage the system, or those persons directly responsible for gathering the information, the information submitted is, to the best of my knowledge and belief true, accurate, and complete. I am aware that there are significant penalties for submitting false information, including the possibility of fine and imprisonment for knowing violations

## 10. DEFINITIONS AND ACRONYMS

“Act” – is a reference to the Utah Water Quality Act, or Utah Code Annotated Title 19, Chapter 5.

“Agricultural Land” - cropland, grassland, rangeland, pasture, and other agricultural land, on which agricultural and forest-related products or livestock are produced and resource concerns may be addressed. Agricultural lands include cropped woodland, marshes, incidental areas included in the agricultural operation, and other types of agricultural land used for the production of livestock.

“Antidegradation Policy” or “Antidegradation Requirements” - the water quality standards regulation that requires maintenance of water quality:

Waters whose existing quality is better than the established standards for the designated uses will be maintained at high quality unless it is determined by the Board, after appropriate intergovernmental coordination and public participation in concert with the Utah continuing planning process, allowing lower water quality is necessary to accommodate important economic or social development in the area in which the waters are located. However, existing instream water uses shall be maintained and protected. No water quality degradation is allowable which would interfere with or become injurious to existing instream water uses.

In those cases where potential water quality impairment associated with a thermal discharge is involved, the antidegradation policy and implementing method shall be consistent with Section 316 of the Federal Clean Water Act.

Category 1 Waters: Waters which have been determined by the Board to be of exceptional recreational or ecological significance or have been determined to be a State or National resource requiring protection, shall be maintained at existing high quality through designation, by the Board after public hearing, as Category 1 Waters. New point source discharges of wastewater, treated or otherwise, are prohibited in such segments after the effective date of designation. Protection of such segments from pathogens in diffuse, underground sources is covered in R317-5 and R317-7 and the Regulations for Individual Wastewater Disposal Systems (R317-501 through R317-515). Other diffuse sources (nonpoint sources) of wastes shall be controlled to the extent feasible through implementation of best management practices or regulatory programs.

Discharges may be allowed where pollution will be temporary and limited after consideration of the factors in R317-2-3.5.b.4., and where best management practices will be employed to minimize pollution effects.

Waters of the state designated as Category 1 Waters are listed in UAC R317-2-12.1.

Category 2 Waters: Category 2 Waters are designated surface water segments which are treated as Category 1 Waters except that a point source discharge may be permitted provided that the discharge does not degrade existing water quality. Discharges may be allowed where pollution will be temporary and limited after consideration of the factors in UAC R317-2-3.5.b.4., and where best management practices will be employed to minimize

pollution effects. Waters of the state designated as Category 2 Waters are listed in UAC R317-2-12.2.

Category 3 Waters: For all other waters of the state, point source discharges are allowed and degradation may occur, pursuant to the conditions and review procedures outlined in in the paragraph below (Antidegradation Review).

Antidegradation Review (ADR): An antidegradation review will determine whether the proposed activity complies with the applicable antidegradation requirements for receiving waters that may be affected.

An antidegradation review (ADR) may consist of two parts or levels. A Level I review is conducted to insure that existing uses will be maintained and protected.

Both Level I and Level II reviews will be conducted on a parameter-by-parameter basis. A decision to move to a Level II review for one parameter does not require a Level II review for other parameters. Discussion of parameters of concern is those expected to be affected by the proposed activity.

Antidegradation reviews shall include opportunities for public participation, as described in UAC R317-2-3.5e.

“Arid Areas” – areas with an average annual rainfall of 0 to 10 inches.

“Bank” (e.g., stream bank or river bank) – the rising ground bordering the channel of a water of the State of Utah.

“Best Management Practices (BMPs) – schedules of activities, prohibitions of practices, maintenance procedures, and other physical, structural and/or managerial practices to prevent or reduce pollution of waters of the State. BMPs include treatment requirements, operating procedures, and practices to control storm water associated with construction activity, spillage or leaks, sludge or waste disposal, or drainage from raw material storage.

“Bluff” – a steep headland, promontory, riverbank, or cliff.

“Borrow Areas” – the areas where materials are dug for use as fill, either onsite or off-site.

“Category 1, 2, and/or 3 Waters” – see “Antidegradation Policy” or “Antidegradation Requirements”.

“Cationic Treatment Chemical” – polymers, flocculants, or other chemicals that contain an overall positive charge. Among other things, they are used to reduce turbidity in storm water discharges by chemically bonding to the overall negative charge of suspended silts and other soil materials and causing them to bind together and settle out. Common examples of cationic treatment chemicals are chitosan and cationic PAM.

“Commencement of Earth-Disturbing Activities” - the initial disturbance of soils (or ‘breaking ground’) associated with clearing, grading, or excavating activities or other construction-related activities (e.g., stockpiling of fill material).

“Commencement of Pollutant-Generating Activities” – at construction sites (for the purposes of this permit) occurs in any of the following circumstances:

- Clearing, grubbing, grading, and excavation has begun;



- Raw materials related to your construction activity, such as building materials or products, landscape materials, fertilizers, pesticides, herbicides, detergents, fuels, oils, or other chemicals have been placed at your site;
- Use of authorized non-storm water for washout activities, or dewatering activities, have begun; or
- Any other activity has begun that causes the generation of or the potential generation of pollutants.

“Common Plan of Development or Sale” –is a plan to subdivide a parcel of land into separate parts for separate sale. This can be for a residential, commercial, or industrial development. The plan originates as a single parcel that is separated into parts. This usually goes through an approval process by a local governmental unit, but in some cases, it may not require that process. The original plan is considered the “common plan of development or sale” whether phased or completed in steps.

Additional information related to Common Plan of Development for Permit Purposes:

For UPDES storm water permit purposes, a common plan must have been initiated after October, 1992. A common plan of development or sale remains so until each lot or section of the development has fulfilled its planned purposes (e.g. in a residential development as homes are completed, stabilized, and sold or occupied). As lots or separated sections of the development are completed, the lot or section is stabilized, and the plan purposes are fulfilled for that area, lot, or section, it is no longer part of the common plan of development or sale (e.g. if a home is sold in a development and the owner decides to add a garage somewhere on the lot, that garage project is not part of the common plan of development or sale. In this process a common plan of development or sale may become reduced in size and/or separated by completed areas which are no longer part of the common plan of development or sale, but all unfinished lots remain part of the same common plan of development or sale until they are completed, stabilized, and fulfilled according to the purposes of the plan.

“Construction Activities” – earth-disturbing activities, such as the clearing, grading, and excavation of land.

“Construction and Development Point Source Category” (C&D Rule) – as published in 40 CFR § 450 is the regulation requiring effluent limitations guidelines (ELG’s) and new source performance standards (NSPS) for controlling the discharge of pollutants from construction sites.

“Construction Site” – the land or water area where construction activities will occur and where storm water controls will be installed and maintained. The construction site includes construction support activities, which may be located at a different part of the property from where the primary construction activity will take place, or on a different piece of property altogether. The construction site is often a smaller subset of the lot or parcel within which the project is taking place.

- “Construction Support Activities” – a construction-related activity that specifically supports the construction activity and involves earth disturbance or pollutant-generating activities of its own. This can include activities associated with concrete or asphalt batch plants, equipment staging yards, materials storage areas, excavated material disposal areas, and borrow areas.
- “Construction Waste” – discarded material (such as packaging materials, scrap construction materials, masonry products, timber, steel, pipe, and electrical cuttings, plastics, and styrofoam).
- “Conveyance Channel” – a temporary or permanent waterway designed and installed to safely convey storm water flow within and out of a construction site.
- “Corrective Action” – for the purposes of the permit, any action taken to (1) repair, modify, or replace any storm water control used at the site; (2) clean up and dispose of spills, releases, or other deposits found on the site; and (3) remedy a permit violation.
- “CWA” – the Clean Water Act or the Federal Water Pollution Control Act, 33 U.S.C. section 1251 et seq.
- “Dewatering” – the act of draining rainwater and/or groundwater from building foundations, vaults, and trenches.
- “Director” – the director of the Division of Water Quality, otherwise known as the Executive Secretary of the Utah Water Quality Board.
- “Discharge” – discharge of storm water or “discharge of a pollutant.”
- “Discharge of a Pollutant” – the addition of any “pollutant” or combination of pollutants to “waters of the State” from any “point source,” or any addition of any pollutant or combination of pollutants to the waters of the State. This includes additions of pollutants into waters of the State from: surface runoff which is collected or channeled by man; discharges through pipes, sewers, or other conveyances, leading into privately owned treatment works. See 40 CFR 122.2.
- “Discharge Point” – for the purposes of this permit, the location where collected and concentrated storm water flows are discharged from the construction site.
- “Discharge-Related Activity” – activities that cause, contribute to, or result in storm water and allowable non-storm water point source discharges, and measures such as the siting, construction, and operation of storm water controls to control, reduce, or prevent pollutants from being discharged.
- “Discharge to an Impaired Water” – for the purposes of this permit, a discharge to an impaired water occurs if the first water of the State to which you discharge is identified by DWQ or EPA pursuant to Section 303(d) of the Clean Water Act as not meeting an applicable water quality standard, or is included in an EPA-approved or DWQ established total maximum daily load (TMDL). For discharges that enter a storm sewer system prior to discharge, the water of the State to which you discharge is the first water of the State that receives the storm water discharge from the storm sewer system.
- “Domestic Waste” – for the purposes of this permit, typical household trash, garbage or rubbish items generated by construction activities.

- “Drought-Stricken Area” – for the purposes of this permit, an area in which the National Oceanic and Atmospheric Administration’s U.S. Seasonal Drought Outlook indicates for the period during which the construction will occur that any of the following conditions are likely: (1) “Drought to persist or intensify”, (2) “Drought ongoing, some improvement”, (3) “Drought likely to improve, impacts ease”, or (4) “Drought development likely”. See [http://www.cpc.ncep.noaa.gov/products/expert\\_assessment/sdo\\_summary.php](http://www.cpc.ncep.noaa.gov/products/expert_assessment/sdo_summary.php)
- “Earth-Disturbing Activity” or “Land-Disturbing Activity” – actions taken to alter the existing vegetation and/or underlying soil of a site, such as clearing, grading, site preparation (e.g., excavating, cutting, and filling), soil compaction, and movement and stockpiling of top soils.
- “Effective Operating Condition” – for the purposes of this permit, a storm water control is kept in effective operating condition if it has been implemented and maintained in such a manner that it is working as designed to minimize pollutant discharges.
- “Effluent Limitations” – for the purposes of this permit, any of the Part 2 or Part 3 requirements.
- “Electronic Notice of Intent” – DWQ’s online system for submitting electronic Construction General Permit forms. Can be accessed at <https://secure.utah.gov/stormwater>.
- “Emergency-Related Project” – a project initiated in response to a public emergency (e.g., natural disaster, disruption in essential public services), for which the related work requires immediate authorization to avoid imminent endangerment to human health or the environment, or to reestablish essential public services.
- “Excursion” – a violation of a standard or limit.
- “Existing Project” – a construction project that commenced construction activities prior to the issuance date of this permit.
- “Existing Permit Coverage” – means that the permittee had permit coverage under a previous permit prior to the issuance of this permit.
- “Exit Points” – any points of egress from the construction site to be used by vehicles and equipment during construction activities.
- “Exposed Soils” – for the purposes of this permit, soils that as a result of earth-disturbing activities are disturbed and exposed to the elements of weather.
- “Final Stabilization” – All disturbed areas must be covered by permanent structures such as pavement, concrete slab, building, etc., or for areas not covered by permanent structures but that are receiving 20 inches or more of average annual precipitation, vegetation has been established with a uniform (e.g., evenly distributed, without large bare areas) perennial vegetative cover equivalent to 70 percent of the natural background vegetative cover. In the case of areas that are not covered by permanent structures, but that are receiving less than 20 inches of average annual precipitation (arid areas, 0-10 inches; semi-arid areas, 10-20 inches), final stabilization is equivalent to the requirements of 2.2.2.b of this permit, including the provisions for permanent stabilization.



“Groundwater” – water in the voids and interstitial spaces around soil particles beneath the surface of the ground, even if it is only temporary.

“Hazardous Materials” or “Hazardous Substances” or “Hazardous or Toxic Waste” – for the purposes of this permit, any liquid, solid, or contained gas that contain properties that are dangerous or potentially harmful to human health or the environment. See also 40 CFR §261.2.

“Impaired Water” or “Water Quality Impaired Water” or “Water Quality Limited Segment” – for the purposes of this permit, waters identified as impaired on the CWA Section 303(d) list, or waters with an EPA-approved or established TMDL. Your construction site will be considered to discharge to an impaired water if the first water of the state to which you discharge is identified by DWQ pursuant to Section 303(d) of the CWA as not meeting an applicable water quality standard, or is included in an EPA-approved or DWQ established total maximum daily load (TMDL). For discharges that enter a storm sewer system prior to discharge, the first water of the state to which you discharge is the water body that receives the storm water discharge from the storm sewer system.

“Impervious Surface” – for the purpose of this permit, any land surface with a low or no capacity for soil infiltration including, but not limited to, pavement, sidewalks, parking areas and driveways, packed gravel or soil, or rooftops.

“Indian Country” or “Indian Country Lands” – defined at 40 CFR §122.2 as:

1. All land within the limits of any Indian reservation under the jurisdiction of the United States Government, notwithstanding the issuance of any patent, and, including rights-of-way running through the reservation;
2. All dependent Indian communities within the borders of the United States whether within the originally or subsequently acquired territory thereof; and
3. All Indian allotments, the Indian titles to which have not been extinguished, including rights-of-ways running through the same.

“Infeasible” – for the purpose of this permit, infeasible means not technologically possible or not economically practicable and achievable in light of best industry practices. DWQ notes that it does not intend for any permit requirement to conflict with state water rights law.

“Install” or “Installation” – when used in connection with storm water controls, to connect or set in position storm water controls to make them operational.

“Intermittent (or Seasonal) Stream” – one which flows at certain times of the year when ground water provides water for stream flow, or during and immediately after some precipitation events or snowmelt.

“Landward” – positioned or located away from a water body, and towards the land.

“Level Spreader” – a temporary storm water control used to spread storm water flow uniformly over the ground surface as sheet flow to prevent concentrated, erosive flows from occurring.

“Linear Construction Project” – includes the construction of roads, bridges, conduits, substructures, pipelines, sewer lines, towers, poles, cables, wires, connectors, switching, regulating and transforming equipment and associated ancillary facilities in a long, narrow area.

“Minimize” – to reduce and/or eliminate to the extent achievable using storm water controls that are technologically available and economically practicable and achievable in light of best industry practices.

“Municipal Separate Storm Sewer System” or “MS4” – defined at 40 CFR §122.26(b)(8) as a conveyance or system of conveyances (including roads with drainage systems, municipal streets, catch basins, curbs, gutters, ditches, manmade channels, or storm drains):

1. Owned and operated by a state, city, town, county, district, association, or other public body (created by or pursuant to State law) having jurisdiction over disposal of sewage, industrial wastes, storm water, or other wastes, including special districts under State law such as a sewer district, flood control district or drainage district, or similar entity, or a designated and approved management agency under section 208 of the CWA that discharges to waters of the State;
2. Designed or used for collecting or conveying storm water;
3. Which is not a combined sewer; and
4. Which is not part of a Publicly Owned Treatment Works (POTW) as defined at 40 CFR §122.2.

“Native Topsoil” – the uppermost layer of naturally occurring soil for a particular area, and is often rich in organic matter, biological activity, and nutrients.

“Native Vegetation” – the species of plants that have developed for a particular region or ecosystem and are considered endemic to that area.

“Natural Buffer” – for the purposes of this permit, an area of undisturbed natural cover surrounding surface waters within which construction activities are restricted. Natural cover includes the vegetation, exposed rock, or barren ground that exists prior to commencement of earth-disturbing activities.

“Natural Vegetation” – vegetation that occurs spontaneously without regular management, maintenance or species introductions, removals, and that generally has a strong component of native species.

“New Operator of a New or Existing Project” – an operator that through transfer and/or operation replaces the operator of an already permitted construction project.

“New Project” – a construction project that commenced construction activities on or the issuance date of this permit.

“New Source” – for the purpose of this permit, a construction project that commenced construction activities on or after the issuance date of this permit.

“New Source Performance Standards (NSPS)” – for the purposes of this permit, NSPS are technology-based standards that apply to construction sites that are new sources under 40 CFR 450.24.

“Non-Storm Water Discharges” – discharges that do not originate from storm events. They can include, but are not limited to, discharges of process water, air conditioner condensate, noncontact

cooling water, vehicle wash water, sanitary wastes, concrete washout water, paint wash water, irrigation water, or pipe testing water.

“Non-Turbid” – is a term used in this permit to describe water that appears visually clear and there appears to be no evidence of silt or sediment present in the water.

“Notice of Intent” (NOI) – the form (electronic or paper) required for authorization of coverage under the Construction General Permit.

“Notice of Termination” (NOT) – the form (electronic or paper) required for terminating coverage under the Construction General Permit.

“Operational” – for the purpose of this permit, storm water controls are made “operational” when they have been installed and implemented, are functioning as designed, and are properly maintained.

“Operator” – for the purposes of this permit and in the context of storm water discharges associated with construction activity, any party associated with a construction project that meets either of the following two criteria:

1. The party which has operational control over construction plans and specifications, including the ability to make modifications to those plans and specifications (e.g. in most cases this is the owner of the site, sometimes it is a lessor); or
2. The party which has day-to-day operational control of those activities at a project that are necessary to ensure compliance with the permit conditions (e.g., they are authorized to direct workers at a site to carry out activities required by the permit; in most cases this is the general contractor of the project).

“Ordinary High Water Mark” – the line on the shore established by fluctuations of water and indicated by physical characteristics such as a clear, natural line impressed on the bank, shelving, changes in the character of soil, destruction of terrestrial vegetation, and/or the presence of litter and debris.

“Outfall” – see “Discharge Point.”

“Owner” – for the purpose of this permit an owner has legal ownership of property on which construction activity is taking place. Except in the case of leased property, an owner is the party that has ultimate control over the destiny of a project. This is the lessor in the case of leased property.

“Permittee” – is the owner and/or operator named in the NOI for the project.

“Point(s) of Discharge” – see “Discharge Point.”

“Point Source” – any discernible, confined, and discrete conveyance, including but not limited to, any pipe, ditch, channel, tunnel, conduit, well, discrete fissure, container, rolling stock concentrated animal feeding operation, landfill leachate collection system, or vessel or other floating craft from which pollutants are or may be discharged. This term does not include return flows from irrigated agriculture or agricultural storm water runoff.



“Pollutant” – defined at 40 CFR §122.2. A partial listing from this definition includes: dredged spoil, solid waste, sewage, garbage, sewage sludge, chemical wastes, biological materials, heat, wrecked or discarded equipment, rock, sand, cellar dirt, and industrial or municipal waste.

“Pollutant-Generating Activities” – at construction sites (for the purposes of this permit), those activities that lead to or could lead to the generation of pollutants, either as a result of earth disturbance or a related support activity. Some of the types of pollutants that are typically found at construction sites are:

- sediment;
- nutrients;
- heavy metals;
- pesticides and herbicides;
- oil and grease;
- bacteria and viruses;
- trash, debris, and solids;
- treatment polymers; and
- any other toxic chemicals.

“Pollution Prevention Measures” – storm water controls designed to reduce or eliminate the addition of pollutants to construction site discharges through analysis of pollutant sources, implementation of proper handling/disposal practices, employee education, and other actions.

“Polymers” – for the purposes of this permit, coagulants and flocculants used to control erosion on soil or to enhance the sediment removal capabilities of sediment traps or basins. Common construction site polymers include polyacrylamide (PAM), chitosan, alum, polyaluminum chloride, and gypsum.

“Prohibited Discharges” – discharges that are not allowed under this permit, including:

1. Wastewater from washout of concrete;
2. Wastewater from washout and cleanout of stucco, paint, form release oils, curing compounds and other construction materials;
3. Fuels, oils, or other pollutants used in vehicle and equipment operation and maintenance;
4. Soaps or solvents used in vehicle and equipment washing;
5. Toxic or hazardous substances from a spill or other release; and
6. Waste, garbage, floatable debris, construction debris, and sanitary waste from pollutant generating activities.

“Provisionally Covered Under this Permit” – for the purposes of this permit, DWQ provides temporary coverage under this permit for emergency-related projects prior to receipt of a complete and

accurate NOI. Discharges from earth-disturbing activities associated with the emergency-related projects are subject to the terms and conditions of the permit during the period of temporary coverage.

“Receiving Water” – a “Water of the State into which the regulated storm water discharges. If the discharge is to a storm sewer system, the receiving water is the waterbody to which the storm system discharges.

“Regulatory Authority” – as it pertains to this permit means EPA, DWQ, or a local MS4 that oversees construction activity.

“Run-On” – sources of storm water that drain from land located upslope or upstream from the regulated site in question.

“Semi-Arid Areas” – areas with an average annual rainfall of over 10 to 20 inches.

“Site” – for construction activities, the land or water area where earth-disturbing activities take place, including construction support activities.

“Small Construction Activity” – defined at Utah Administrative Code R317-8-3.9(6)(e)1. and incorporated here by reference. A small construction activity includes clearing, grading, and excavating resulting in a land disturbance that will disturb equal to or greater than one (1) acre and less than five (5) acres of land or will disturb less than one (1) acre of total land area but is part of a larger common plan of development or sale that will ultimately disturb equal to or greater than one (1) acre and less than five (5) acres. Small construction activity does not include routine maintenance that is performed to maintain the original line and grade, hydraulic capacity, or original purpose of the site.

“Small Residential Lot” – for the purpose of this permit, a lot being developed for residential purposes that will disturb less than 1 acre of land, but is part of a larger residential project that will ultimately disturb greater than or equal to 1 acre.

“Snowmelt” – the conversion of snow into overland storm water and groundwater flow as a result of warmer temperatures.

“Spill” – for the purpose of this permit, the release of a hazardous or toxic substance from its container or containment.

“Stabilization” – the use of vegetative and/or non-vegetative cover to prevent erosion and sediment loss in areas of disturbed soil exposed from the construction process.

“Steep Slopes” –for this permit steep slopes are defined as those that are 70 percent or greater in grade.

“Storm Event” – a precipitation event that results in a measurable amount of precipitation.

“Storm Sewer” – a system of pipes (separate from sanitary sewers) that carries storm water runoff from buildings and land surfaces.

“Storm Sewer System” – a conveyance or system of conveyances (including roads with drainage systems, municipal streets, catch basins, curbs, gutters, ditches, manmade channels, or storm drains) designed or used for collecting or conveying storm water.

“Storm Water” – storm water runoff from precipitation, snow melt runoff, and surface runoff and drainage.

“Storm Water Control Measure” - refers to any storm water control, BMP, or other method (including narrative effluent limitations) used to prevent or reduce the discharge of pollutants to waters of the state.

“Storm Water Controls” – see “Storm Water Control measure.”

“Storm Water Discharge Associated with Construction Activity” – as used in this permit, a discharge of pollutants in storm water to waters of the state from areas where land disturbing activities (e.g., clearing, grading, or excavation) occur, or where construction materials or equipment storage or maintenance (e.g., fill piles, borrow area, concrete truck chute wash down, fueling), or other industrial storm water directly related to the construction process (e.g., concrete or asphalt batch plants), are located.

“Storm Water Inlet” or “Storm Drain Inlet” – an entrance or opening to a storm water conveyance system, generally placed below grade so as to receive storm water drainage from the surrounding area.

“Storm Water Team” – the group of individuals responsible for oversight of the development and modifications of the SWPPP, and oversight of compliance with the permit requirements. The individuals on the “Storm water Team” must be identified in the SWPPP.

“Subcontractor” – for the purposes of this permit, an individual or company that takes a portion of a contract from the general contractor or from another subcontractor.

“Surface Water” – for this permit a surface water is defined all open water bodies, streams, lakes, ponds, marshes, wetlands, watercourses, waterways, springs, drainage systems, and all other bodies or accumulations of water on the surface only. Surface water is visible water, standing or flowing, above the surface of the ground.

“SWPPP” (Storm Water Pollution Prevention Plan) – a site-specific, written document that, among other things: (1) identifies potential sources of storm water pollution at the construction site; (2) describes storm water control measures to reduce or eliminate pollutants in storm water discharges from the construction site; and (3) identifies procedures the operator will implement to comply with the terms and conditions of this general permit.

“Temporary Stabilization” – a condition where exposed soils or disturbed areas are provided a temporary vegetative and/or non-vegetative protective cover to prevent erosion and sediment loss. Temporary stabilization may include temporary seeding, geotextiles, mulches, and other techniques to reduce or eliminate erosion until either final stabilization can be achieved or until further construction activities take place to re-disturb this area.

“Thawing Conditions” – for the purposes of this permit, thawing conditions are expected based on the historical likelihood of two or more days with daytime temperatures greater than 32°F. This date can be determined by looking at historical weather data. The estimation of thawing conditions is for planning purposes only. During construction the permittee will be required to conduct site inspections based upon actual conditions (i.e., if thawing conditions occur



sooner than expected, the permittee will be required to conduct inspections at the regular frequency).

“Total Maximum Daily Load” or “TMDL” – the sum of the individual wasteload allocations (WLAs) for point sources and load allocations (LAs) for nonpoint sources and natural background. If a receiving water has only one point source discharger, the TMDL is the sum of that point source WLA plus the LAs for any nonpoint sources of pollution and natural background sources, tributaries, or adjacent segments. TMDLs can be expressed in terms of either mass per time, toxicity, or other appropriate measure.

“Toxic Waste” – see “Hazardous Materials.”

“Turbidity” – when the term is used in a narrative it means a condition of water quality characterized by the presence of cloudiness usually caused by suspended solids and/or organic material. It refers to the visual clarity in water and is measured in a test passing light through a sample of water and quantifying the amount of light passing. The measurement is not directly proportional to the quantity of sediment in the water sample it is directly related to the quantity of light that passes through the sample. Particulate size and other factors can affect the amount of light that passes through the sample. This measurement is called nephelometric turbidity units or ntu.

“Uncontaminated Discharge” – a discharge that does not cause or contribute to an exceedance of applicable water quality standards.

“Upland” - the dry land area above and ‘landward’ of the ordinary high water mark.

“Utah Pollutant Discharge Elimination System (UPDES)” – The State of Utah’s program for issuing, modifying, revoking and reissuing, terminating, monitoring, and enforcing permits, and imposing and enforcing pretreatment requirements, under sections 307, 102, 318, and 405 of the Clean water Act (CWA) for the “discharge” of “pollutants” to “Waters of the State”. This program is specifically designed to be compatible with the federal National Pollutant Discharge Elimination System (NPDES) program established and administered by the EPA.

“Water-Dependent Structures” – structures or facilities that are required to be located directly adjacent to a waterbody or wetland, such as a marina, pier, boat ramp, etc.

“Water Quality Standards” –are provisions of State law which consist of a designated use or uses for the waters of the United States, water quality criteria for such waters based upon such uses, and an antidegradation policy to protect high quality waters. Water quality standards protect the public health or welfare, enhance the quality of water and serve the purposes of the Utah Water Quality Act.

“Waters of the State” – means all streams, lakes, ponds, marshes, water-courses, waterways, wells, springs, irrigation systems, drainage systems, and all other bodies or accumulations of water, surface and underground, natural or artificial, public or private, which are contained within, flow through, or border upon this state or any portion thereof, except that bodies of water confined to and retained within the limits of private property, and which do not develop into or constitute a nuisance, or a public health hazard, or a menace to fish and

wildlife, shall not be considered to be "waters of the state" under this definition (Section 19-5-102).

“Wetland” – those areas that are inundated or saturated by surface or groundwater at a frequency and duration sufficient to support, and that under normal circumstances do support, a prevalence of vegetation typically adapted for life in saturated soil conditions. Wetlands generally include swamps, marshes, bogs, and similar areas. On-site evaluations are typically required to confirm the presence and boundaries of wetlands.

“Work day” – for the purposes of this permit, a work day is a calendar day on which construction activities will take place.

#### Acronyms

C&D – Construction & Development  
CGP – Construction General Permit  
CFR – Code of Federal Regulations  
CPoD – Common Plan of Development or Sale  
CWA – Clean Water Act  
DEQ – Department of Environmental Quality  
DDW – Division of Drinking Water  
DWQ – Division of Water Quality  
EPA – United States Environmental Protection Agency  
MS4 – Municipal Separate Storm Sewer System  
NMFS – United States National Marine Fisheries Service  
NOI – Notice of Intent  
NOT – Notice of Termination  
NPDES – National Pollutant Discharge Elimination System  
NRC – National Response Center  
NRCS – National Resources Conservation Service  
POTW – Publicly Owned Treatment Works  
SPCC – Spill Prevention Control and Countermeasure  
SW – Storm Water  
SWMP – Storm Water Management Plan  
SWPPP – Storm Water Pollution Prevention Plan  
TMDL – Total Maximum Daily Load  
UAC – Utah Administrative Code  
UCA – Utah Code Annotated  
UPDES – Utah Pollution Discharge Elimination System  
UWQA – Utah Water Quality Act  
WQS – Water Quality Standard

## Appendix A

### Buffer Requirements

The purpose of this appendix is to assist you in complying with the requirements in Part 2.2.1 of the permit regarding the establishment of natural buffers and/or equivalent sediment controls. This appendix is organized as follows:

A.1. SITES THAT ARE REQUIRED TO PROVIDE AND MAINTAIN NATURAL BUFFERS AND/OR EQUIVALENT EROSION AND SEDIMENT CONTROLS.....	A-2
A.2. COMPLIANCE ALTERNATIVES AND EXCEPTIONS.....	A-2
A.2.1. Compliance Alternatives.....	A-2
A.2.2. Exceptions to Compliance Alternatives.....	A-3
A.2.3. Requirements for Providing and Maintaining Natural Buffers.....	A-4
A.2.4. Guidance for Providing the Equivalent Sediment Reduction as a 50-foot Buffer.....	A-7
A.3. SMALL RESIDENTIAL LOT COMPLIANCE ALTERNATIVES.....	A-11
A.3.1. Small Residential Lot Compliance Alternative Eligibility.....	A-11
A.3.2. Small Residential Lot Compliance Alternatives.....	A-12
Attachment 1 –Sediment Removal Efficiency Tables.....	A-16
Attachment 2 – Using the Sediment Removal Efficiency Tables – Questions and Answers.....	A-18
Attachment 3 – Example of How to Use the Sediment Removal Efficiency Tables.....	A-19



## A.1 SITES THAT ARE REQUIRED TO PROVIDE AND MAINTAIN NATURAL BUFFERS AND/OR EQUIVALENT EROSION AND SEDIMENT CONTROLS

The requirement in Part 2.2.1 to provide and maintain natural buffers and/or equivalent erosion and sediment controls applies for any discharges to waters of the state located within 50 feet of your site's earth disturbances. If the water of the state is not located within 50 feet of earth-disturbing activities, Part 2.2.1 does not apply. See Figure A-1.

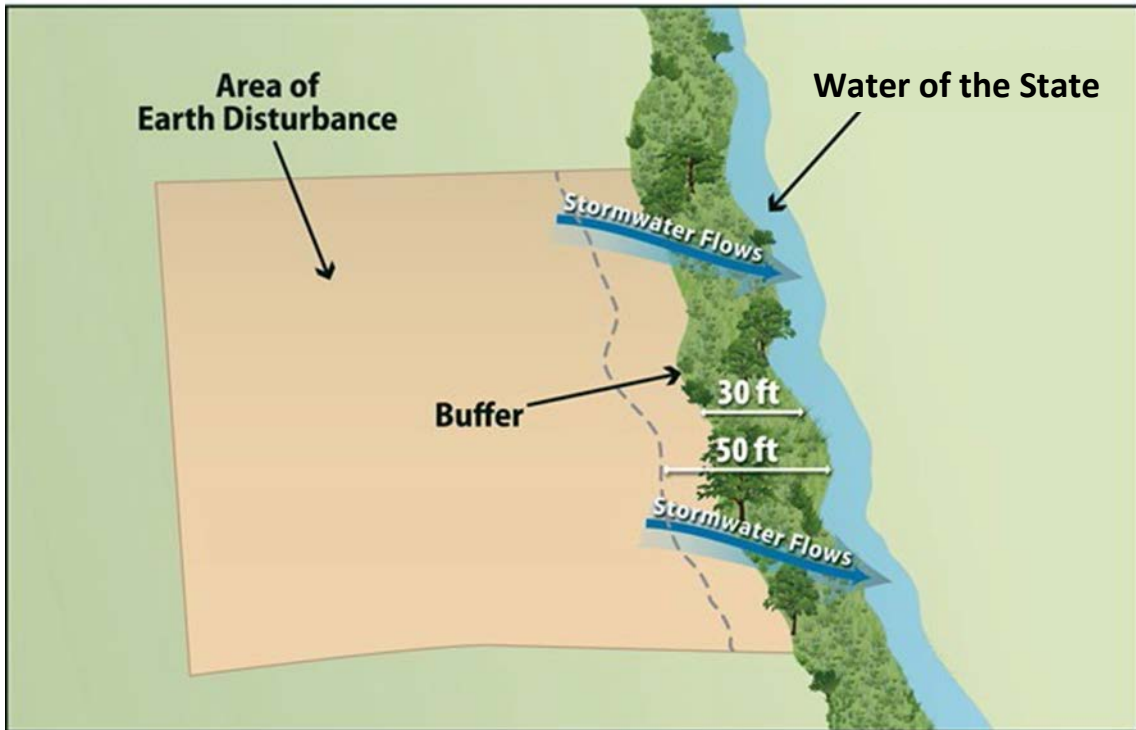

Figure A-1 Example of earth-disturbing activities within 50 feet of a water of the state.

## A.2 COMPLIANCE ALTERNATIVES AND EXCEPTIONS

### A.2.1. Compliance Alternatives

If Part 2.2.1 applies to your site, you have three compliance alternatives from which you can choose, unless you qualify for any of the exceptions (see below and Part 2.2.1.a):

1. Provide and maintain a 50-foot undisturbed natural buffer; or
2. Provide and maintain an undisturbed natural buffer that is less than 50 feet and is supplemented by erosion and sediment controls that achieve the sediment load reduction equivalent to a 50-foot undisturbed natural buffer; or
3. If infeasible to provide and maintain an undisturbed natural buffer of any size, implement erosion and sediment controls to achieve the sediment load reduction equivalent to a 50-foot undisturbed natural buffer.

The compliance alternative selected must be maintained throughout the duration of permit coverage.

See Part A.2.2 below for exceptions to the compliance alternatives.

See Part A.2.3 for requirements applicable to providing and maintaining natural buffers under compliance alternatives 1 and 2 above.

See Part A.2.4 for requirements applicable to providing erosion and sediment controls that achieve the sediment load reduction equivalent to a 50-foot undisturbed natural buffer under compliance alternatives 2 and 3 above.

### **A.2.2. Exceptions to the Compliance Alternatives**

The following exceptions apply to the requirement to implement one of the Part 2.2.1.a compliance alternatives (see also Part 2.2.1.b):

- The following disturbances within 50 feet of a water of the state are exempt from the requirements Part 2.2.1 and this Appendix:
  - Construction approved under a CWA Section 404 permit; or
  - Construction of a water-dependent structure or water access areas (e.g., pier, boat ramp, trail).
- If there is no discharge of storm water to waters of the state through the area between the disturbed portions of the site and any waters of the state located within 50 feet of your site, you are not required to comply with the requirements in Part 2.2.1 and this Appendix. This includes situations where you have implemented controls measures, such as a berm or other barrier that will prevent such discharges.
- Where no natural buffer exists due to preexisting development disturbances (e.g., structures, impervious surfaces) that occurred prior to the initiation of planning for the current development of the site, you are not required to comply with the requirements in Part 2.2.1 and this Appendix.

Where some natural buffer exists but portions of the area within 50 feet of the water of the state are occupied by preexisting development disturbances, you are required to comply with the requirements in Part 2.2.1 and this Appendix. For the purposes of calculating the sediment load reduction for either compliance alternative 2 or 3, you are not expected to compensate for the reduction in buffer function that would have resulted from the area covered by these preexisting disturbances. Clarity about how to implement the compliance alternatives for these situations is provided in A.2.3 and A.2.4 below.

If during your project, you will disturb any portion of these preexisting disturbances, the area removed will be deducted from the area treated as a “natural buffer.”

- For “linear construction sites” (see Definitions), you are not required to comply with this requirement if site constraints (e.g., limited right-of-way) make it infeasible to implement one of the Part 2.2.1.a compliance alternatives, provided that, to the extent feasible, you limit disturbances within 50 feet of any waters of the state and/or you provide supplemental erosion and sediment controls to treat storm water discharges from earth

disturbances within 50 feet of the water of the state. You must also document in your SWPPP your rationale for why it is infeasible for you to implement one of the Part 2.2.1.a compliance alternatives, and describe any buffer width retained and supplemental erosion and sediment controls installed.

- For “small residential lot” construction (i.e., a lot being developed for residential purposes that will disturb less than 1 acre of land, but is part of a larger residential project that will ultimately disturb greater than or equal to 1 acre), you have the option of complying with one of the “small residential lot” compliance alternatives in Part A.3 of this appendix.

Note that you must document in your SWPPP if any disturbances related to any of the above exceptions occurs within the buffer area on your site.

### **A.2.3. Requirements for Providing and Maintaining Natural Buffers**

This part applies to you if you choose compliance alternative 1 (50-foot buffer), compliance alternative 2 (a buffer of < 50 feet supplemented by additional erosion and sediment controls that achieve the equivalent sediment load reduction as the 50-foot buffer), or if you are providing a buffer in compliance with one of the “small residential lot” compliance alternatives in Part A.3.

#### **Buffer Width Measurement**

Where you are retaining a buffer of any size, the buffer should be measured perpendicularly from any of the following points, whichever is further landward from the water:

4. The ordinary high water mark of the water body, defined as the line on the shore established by fluctuations of water and indicated by physical characteristics such as a clear, natural line impressed on the bank, shelving, changes in the character of soil, destruction of terrestrial vegetation, and/or the presence of litter and debris; or
5. The edge of the stream or river bank, bluff, or cliff, whichever is applicable.

Refer to Figure A-2 and Figure A-3. You may find that specifically measuring these points is challenging if the flow path of the water of the state changes frequently, thereby causing the measurement line for the buffer to fluctuate continuously along the path of the waterbody. Where this is the case, DWQ suggests that rather than measuring each change or deviation along the water’s edge, it may be easier to select regular intervals from which to conduct your measurement. For instance, you may elect to conduct your buffer measurement every 5 to 10 feet along the length of the water.

Additionally, note that if earth-disturbing activities will take place on both sides of a water of the state that flows through your site, to the extent that you are establishing a buffer around this water, it must be established on both sides. For example, if you choose compliance alternative 1, and your project calls for disturbances on both sides of a small stream, you would need to retain the full 50 feet of buffer on both sides of the water. However, if your construction activities will only occur on one side of the stream, you would only need to retain the 50-foot buffer on the side of the stream where the earth- disturbance will occur.



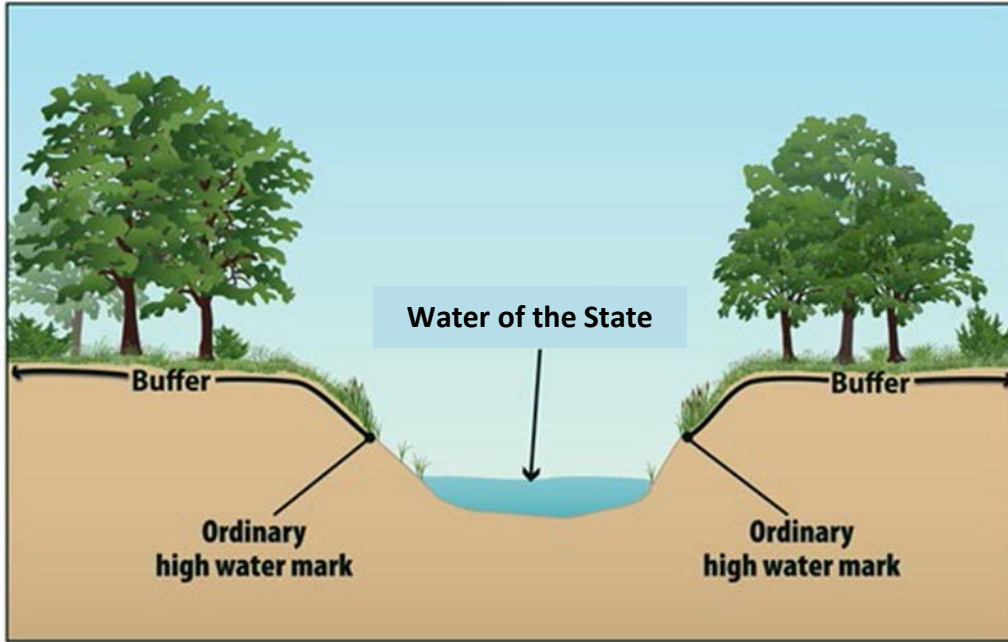

Figure A-2 Buffer measurement from the ordinary high water mark of the water body, as indicated by a clear natural line impressed on the bank, shelving, changes in the character of the soil, destruction of terrestrial vegetation, and/or the presence of litter/debris.

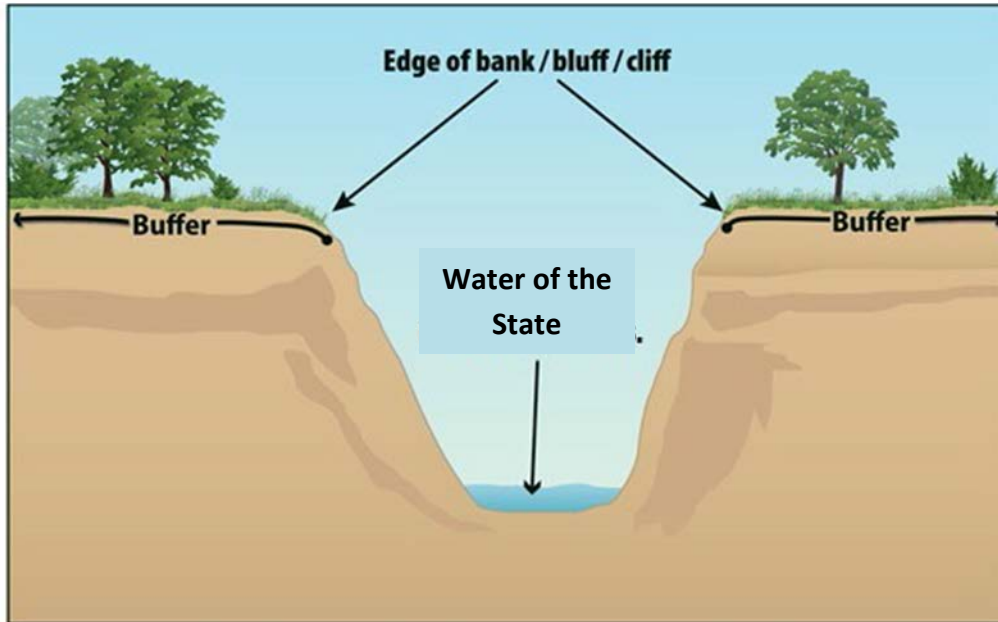

Figure A-3 Buffer measurement from the edge of the bank, bluff, or cliff, whichever is applicable.

#### Limits to Disturbance Within the Buffer

You are considered to be in compliance with the requirement to provide and maintain a natural buffer if you retain and protect from construction activities the natural buffer that existed prior to the commencement of construction. If the buffer area contains no vegetation prior to the

commencement of construction (e.g., sand or rocky surface), you are not required to plant vegetation. As noted above, any preexisting structures or impervious surfaces may occur in the natural buffer provided you retain and protect from disturbance the buffer areas outside of the preexisting disturbance.

To ensure that the water quality protection benefits of the buffer are retained during construction, you are prohibited from conducting any earth-disturbing activities within the buffer during permit coverage. In furtherance of this requirement, **prior to commencing earth-disturbing activities on your site, you must delineate, and clearly mark off, with flags, tape, or a similar marking device, the buffer area on your site.** The purpose of this requirement is to make the buffer area clearly visible to the people working on your site so that unintended disturbances are avoided.

While you are not required to enhance the quality of the vegetation that already exists within the buffer, you are encouraged to do so where such improvements will enhance the water quality protection benefits of the buffer. (Note that any disturbances within the buffer related to buffer enhancement are permitted and do not constitute construction disturbances.) For instance, you may want to target plantings where limited vegetation exists, or replace existing vegetation where invasive or noxious plant species (see <http://plants.usda.gov/java/noxiousDriver>) have taken over. In the case of invasive or noxious species, you may want to remove and replace them with a diversity of native trees, shrubs, and herbaceous plants that are well-adapted to the climatic, soil, and hydrologic conditions on the site. You are also encouraged to limit the removal of naturally deposited leaf litter, woody debris, and other biomass, as this material contributes to the ability of the buffer to retain water and filter pollutants.

If a portion of the buffer area adjacent to the water of the state is owned by another party and is not under your control, you are only required to retain and protect from construction activities the portion of the buffer area that is under your control. For example, if you comply with compliance alternative 1 (provide and maintain a 50-foot buffer), but 10 feet of land immediately adjacent to the water of the U.S. is owned by a different party than the land on which your construction activities are taking place and you do not have control over that land, you must only retain and protect from construction activities the 40-foot buffer area that occurs adjacent to the property on which your construction activities are taking place. DWQ would consider you to be in compliance with this requirement regardless of the activities that are taking place in the 10-foot area that is owned by a different party than the land on which your construction activities are taking place that you have no control over.

#### **Discharges to the Buffer**

**You must ensure that all discharges from the area of earth disturbance to the natural buffer are first treated by the site's erosion and sediment controls** (for example, you must comply with the Part 2.2.3 requirement to install sediment controls along any perimeter areas of the site that will receive pollutant discharges), **and if necessary to prevent erosion caused by storm water flows within the buffer, you must use velocity dissipation devices.** The purpose of this requirement is to decrease the rate of storm water flow and encourage infiltration so that the pollutant filtering functions of the buffer will be achieved. To comply with this requirement,

construction operators typically will use devices that physically dissipate storm water flows so that the discharge entering the buffer is spread out and slowed down.

### **SWPPP Documentation**

You are required to document in your SWPPP the natural buffer width that is retained. For example, if you are complying with alternative 1, you must specify in your SWPPP that you are providing a 50-foot buffer. Or, if you will be complying with alternative 2, you must document the reduced width of the buffer you will be retaining (and you must also describe the erosion and sediment controls you will use to achieve an equivalent sediment reduction, as required in Part A.2.4 below). Note that you must also show any buffers on your site map in your SWPPP consistent with Part 7.3.3.h. Additionally, if any disturbances related to the exceptions in Part A.2.2 occur within the buffer area, you must document this in the SWPPP.

#### **A.2.4 Guidance for Providing the Equivalent Sediment Reduction as a 50-foot Buffer**

This part applies to you if you choose compliance alternative 2 (provide and maintain a buffer that is less than 50 feet that is supplemented by erosion and sediment controls that achieve the sediment load reduction equivalent to a 50-foot buffer) or compliance alternative 3 (implement erosion and sediment controls to achieve the sediment load reduction equivalent to a 50-foot buffer).

#### **Determine Whether it is Feasible to Provide a Reduced Buffer**

EPA recognizes that there will be a number of situations in which it will be infeasible to provide and maintain a buffer of any width. While some of these situations may exempt you from the buffer requirement entirely (see A.2.2), if you do not qualify for one of these exemptions, there still may be conditions or circumstances at your site that make it infeasible to provide a natural buffer. For example, there may be sites where a significant portion of the property on which the earth-disturbing activities will occur is located within the buffer area, thereby precluding the retention of natural buffer areas.

Therefore, you should choose compliance alternative 2 if it is feasible for you to retain some natural buffer on your site. (Note: For any buffer width retained, you are required to comply with the requirements in Part A.2.3, above, concerning the retention of vegetation and restricting earth disturbances.) Similarly, if you determine that it is infeasible to provide a natural buffer of any size during construction, you should choose alternative 3.

#### **Design Controls That Provide Equivalent Sediment Reduction as 50-foot Buffer**

You must next determine what additional controls must be implemented on your site that, alone or in combination with any retained natural buffer, achieve a reduction in sediment equivalent to that achieved by a 50-foot buffer.

Note that if only a portion of the natural buffer is less than 50 feet, you are only required to implement erosion and sediment controls that achieve the sediment load reduction equivalent to the 50-foot buffer for discharges through that area. You would not be required to provide additional treatment of storm water discharges that flow through 50 feet or more of natural buffer. See Figure A-4.



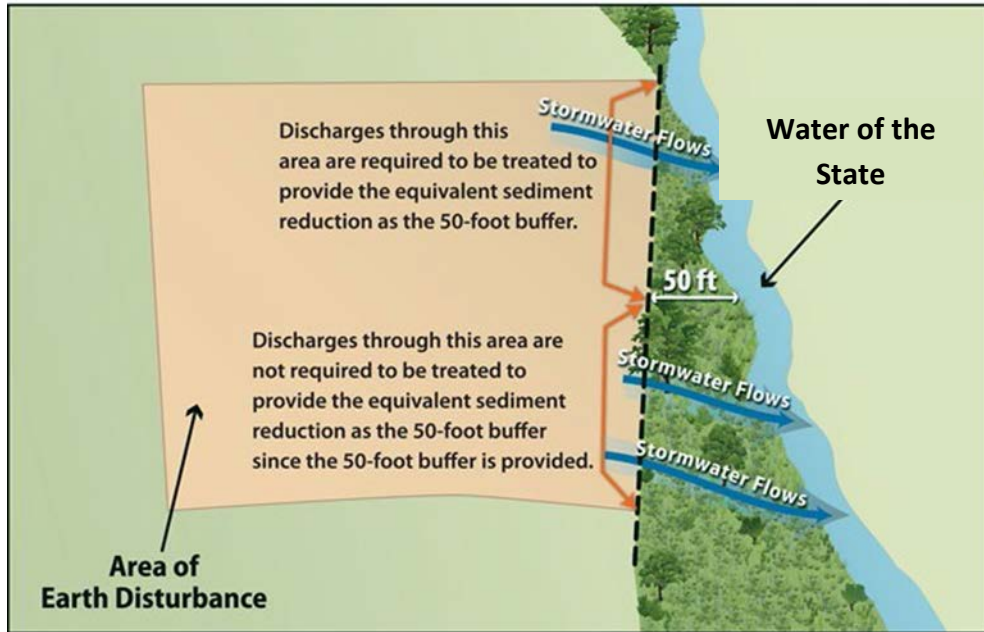

**Figure A-4 Example of how to comply with the requirement to provide the equivalent sediment reduction when only a portion of your earth-disturbances discharge to a buffer of less than 50- feet.**

Steps to help you meet compliance alternative 2 and 3 requirements are provided below.

**Step 1 - Estimate the Sediment Reduction from the 50-foot Buffer**

In order to design controls that match the sediment removal efficiency of a 50-foot buffer, you first need to know what this efficiency is for your site. The sediment removal efficiencies of natural buffers vary according to a number of site-specific factors, including precipitation, soil type, land cover, slope length, width, steepness, and the types of erosion and sediment controls used to reduce the discharge of sediment prior to the buffer. EPA has simplified this calculation by developing buffer performance tables covering a range of vegetation and soil types for the areas covered by the CGP. See Attachment 1 of this Appendix, Tables A-8 and A-9. Note: buffer performance values in Tables A-8 and A-9 represent the percent of sediment captured through the use of perimeter controls (e.g., silt fences) and 50-foot buffers at disturbed sites of fixed proportions and slopes.<sup>39</sup> The number of tables has been reduced since many were irrelevant and

<sup>39</sup> EPA used the following when developing the buffer performance tables:

- The sediment removal efficiencies are based on the U.S. Department of Agriculture’s RUSLE2 (“Revised Universal Soil Loss Equation 2”) model for slope profiles using a 100-foot long denuded slopes.
- Sediment removal was defined as the annual sediment delivered at the downstream end of the 50-foot natural buffer (tons/yr/acre) divided by the annual yield from denuded area (tons/yr/acre).
- As perimeter controls are also required by the CGP, sediment removal is in part a function of the reduction due to a perimeter control (i.e., silt fence) located between the disturbed portion of the site and the upstream edge of the natural buffer and flow traveling through a 50-foot buffer of undisturbed natural vegetation.
- It was assumed that construction sites have a relatively uniform slope without topographic features that accelerate the concentration for erosive flows. (footnote continues on next page)

Table A-8 for Idaho most closely represents northern Utah, and Table A-9 for New Mexico most closely represents southern Utah.

Using Table A-8 for northern Utah or A-9 for southern Utah (see Attachment 1 of this Appendix), you can determine the sediment removal efficiency of a 50-foot buffer for your geographic area by matching the vegetative cover type that best describes your buffer area and the type of soils that predominate at your site. For example, if your site is located in Idaho (northern Utah --Table A-8), and your buffer vegetation corresponds most closely with that of tall fescue grass, and the soil type at your site is best typified as sand, your site's sediment removal efficiency would be 44 percent.

In this step, you should choose the vegetation type in the tables that most closely matches the vegetation that would exist naturally in the buffer area on your site regardless of the condition of the buffer. However, because you are not required to plant any additional vegetation in the buffer area, in determining what controls are necessary to meet this sediment removal equivalency in Step 2 below, you will be able to take credit for this area as a fully vegetated "natural buffer."

Similarly, if a portion of the buffer area adjacent to the water of the state is owned by another party and is not under your control, you can treat the area of land not under your control as having the equivalent vegetative cover and soil type that predominates on the portion of the property on which your construction activities are occurring.

*For example, if your earth-disturbances occur within 50 feet of a water of the state, but the 10 feet of land immediately adjacent to the water of the state is owned by a different party than the land on which your construction activities are taking place and you do not have control over that land, you can treat the 10 foot area adjacent to the stream as having the equivalent soil and vegetation type that predominates in the 40 foot area under your control. You would then make the same assumption in Step 2 for purposes of determining the equivalent sediment removal (which would be 44% in this case).*

Alternatively, you may do your own calculation of the effectiveness of the 50-foot buffer based upon your site-specific conditions, and may use this number as your sediment removal equivalency standard to meet instead of using Tables A-8 and A-9. This calculation must be documented in your SWPPP.

## **Step 2 - Design Controls That Match the Sediment Removal Efficiency of the 50-foot Buffer**

- 
- It was assumed that vegetation has been removed from the disturbed portion of the site and a combination of cuts and fills have resulted in a smooth soil surface with limited retention of near-surface root mass.

To represent the influence of soil, EPA analyzed 11 general soil texture classifications in its evaluation of buffer performance. To represent different types of buffer vegetation, EPA evaluated 4 or more common vegetative types for each state/territory covered under the permit. For each vegetation type evaluated, EPA considered only permanent, non-grazed, and non-harvested vegetation, on the assumption that a natural buffer adjacent to the water of the U.S. will typically be undisturbed. EPA also evaluated slope steepness and found that sediment removal efficiencies present in Tables A-8 and A-9 are achievable for slopes that are less than nine percent.

Once you determine the estimated sediment removal efficiency of a 50-foot buffer for your site in Step 1, you must next select storm water controls that will provide an equivalent sediment load reduction. These controls can include the installation of a single control, such as a sediment pond or additional perimeter controls, or a combination of storm water controls. Whichever control(s) you select, you must demonstrate in your SWPPP that the controls will provide at a minimum the same sediment removal capabilities as a 50-foot natural buffer (Step 1). You may take credit for the removal efficiencies of your required perimeter controls in your calculation of equivalency, because these were included in calculating the buffer removal efficiencies in Tables C-8 through C-9. (Note: You are reminded that the controls must be kept in effective operating condition until you complete final stabilization on the disturbed portions of the site discharging to the water of the state)

To make the determination that your controls and/or buffer area achieve an equivalent sediment load reduction as a 50-foot buffer, you should use a model or other type of calculation. As mentioned above, there are a variety of models available that can be used to support your calculation, including USDA's RUSLE-series programs and the WEPP erosion model, SEDCAD, SEDIMOT, or other models. An example is provided in Attachment 3 to help illustrate how this determination could be made.

If you retain a buffer of less than 50 feet, you may take credit for the removal that will occur from the reduced buffer and only need to provide additional controls to make up the difference between the removal efficiency of a 50 foot buffer and the removal efficiency of the narrower buffer. For example, if you retain a 30 foot buffer, you can account for the sediment removal provided by the 30 foot buffer retained, and you will only need to design controls to make up for the additional removal provided by the 20 feet of buffer that is not being provided. To do this, you would plug the width of the buffer that is retained into RUSLE or another model, along with other storm water controls that will together achieve a sediment reduction equivalent to a natural 50-foot buffer.

As described in Step 1 above, you can take credit for the area you retained as a "natural buffer" as being fully vegetated, regardless of the condition of the buffer area.

*For example, if your earth-disturbances occur 30 feet from a water of the state, but the 10 feet of land immediately adjacent to the water of the U.S. is owned by a different party than the land on which your construction activities are taking place and you do not have control over that land, you can treat the 10-foot area as a natural buffer, regardless of the activities that are taking place in the area. Therefore, you can assume (for purposes of your equivalency calculation) that your site is providing the sediment removal equivalent of a 30-foot buffer, and you will only need to design controls to make up for the additional removal provided by the 20-foot of buffer that is not being provided.*

### **Step 3 - Document How Site-Specific Controls Will Achieve the Sediment Removal Efficiency of the 50-foot Buffer**

In Steps 1 and 2, you determined both the expected sediment removal efficiency of a 50-foot buffer at your site, and you used this number as a performance standard to design controls to be installed at your site, which alone or in combination with any retained natural buffer, achieves



the expected sediment removal efficiency of a 50-foot buffer at your site. The final step is to document in your SWPPP the information you relied on to calculate the equivalent sediment reduction as an undisturbed natural buffer.

DWQ will consider your documentation to be sufficient if it generally meets the following:

- For Step 1, refer to the table in Attachment 1 that you used to derive your estimated 50-foot buffer sediment removal efficiency performance. Include information about the buffer vegetation and soil type that predominate at your site, which you used to select the sediment load reduction value in Tables A-8 and A-9. Or, if you conducted a site-specific calculation for sediment removal efficiency, provide the specific removal efficiency, and the information you relied on to make your site-specific calculation.
- For Step 2, (1) Specify the model you used to estimate sediment load reductions from your site; and (2) the results of calculations showing how your controls will meet or exceed the sediment removal efficiency from Step 1.

If you choose compliance alternative 3, you must also include in your SWPPP a description of why it is infeasible for you to provide and maintain an undisturbed natural buffer of any size.

### A.3 SMALL RESIDENTIAL LOT COMPLIANCE ALTERNATIVES

EPA has developed two additional compliance alternatives applicable only to “small residential lots” that are unable to provide and maintain a 50 foot buffer.

The following steps describe how a small residential lot operator would achieve compliance with one these 2 alternatives.

A small residential lot (Common Plan Lot) is a lot or grouping of lots being developed for residential purposes that will disturb less than 1 acre of land, but that is part of a larger residential project that will ultimately disturb greater than or equal to 1 acre.

#### A.3.1 Small Residential Lot Compliance Alternative Eligibility

In order to be eligible for the small residential lot compliance alternatives, the following conditions must be met:

6. The lot or grouping of lots meets the definition of “small residential lot”; and
7. The operator must follow the guidance for providing and maintaining a natural buffer in Part A.2.3 of this Appendix, including:
  - Ensure that all discharges from the area of earth disturbance to the natural buffer are first treated by the site’s erosion and sediment controls, and use velocity dissipation devices if necessary to prevent erosion caused by storm water within the buffer;
  - Document in the SWPPP the natural buffer width retained on the property, and show the buffer boundary on your site plan; and

- Delineate, and clearly mark off, with flags, tape, or other similar marking device, all natural buffer areas.

**A.3.2. Small Residential Lot Compliance Alternatives**

You must next choose from one of two small residential lot compliance alternatives and implement the storm water control practices associated with that alternative.

*Note: The compliance alternatives provided below are not mandatory. Operators of small residential lots can alternatively choose to comply with the any of the options that are available to other sites in Part 2.2.1.a and A.2.1 of this Appendix.*

**Small Residential Lot Compliance Alternative 1**

Alternative 1 is a straightforward tiered-technology approach that specifies the controls that a small residential lot must implement based on the buffer width retained. To meet the requirements of small residential lot compliance alternative 1, you must implement the controls specified in Table A-1 based on the buffer width to be retained. See footnote 40, below, for a description of the controls you must implement.

*For example, if you are an operator of a small residential lot that will be retaining a 35-foot buffer and you choose Small Residential Lot Compliance Alternative 1, you must implement double perimeter controls between earth disturbances and the water of the state.*

In addition to implementing the applicable control, you must also document in your SWPPP how you will comply with small residential lot compliance alternative 1.

**Table A-1 Alternative 1 Requirements<sup>40</sup>**

Retain 50 foot Buffer	Retain <50 and >30 Buffer	Retain ≤30 foot Buffer
No Additional Requirements	Double Perimeter Controls	Double Perimeter Controls and 7-Day Site Stabilization

**Small Residential Lot Compliance Alternative 2**

Alternative 2 specifies the controls that a builder of a small residential lot must implement based on both the buffer width retained and the site’s sediment discharge risk. By incorporating the

---

<sup>40</sup>Description of Additional Controls Applicable to Small Residential Lot Compliance Alternatives 1 and 2:

- **No Additional Requirements:** If you implement a buffer of 50 feet or greater, then you are not subject to any additional requirements. Note that you are required to install perimeter controls between the disturbed portions of your site and the buffer in accordance with Part 2.2.3.
- **Double Perimeter Control:** In addition to the reduced buffer width retained on your site, you must provide a double row of perimeter controls between the disturbed portion of your site and the water of the U.S. spaced a minimum of 5 feet apart.
- **Double Perimeter Control and 7-Day Site Stabilization:** In addition to the reduced buffer width retained on your site and the perimeter control implemented in accordance with Part 2.2.3, you must provide a double row of perimeter controls between the disturbed portion of your site and the water of the U.S. spaced a minimum of 5 feet apart, and you are required to complete the stabilization activities specified in Parts 2.2.14 within 7 calendar days of the temporary or permanent cessation of earth-disturbing activities.

sediment risk, this approach may result in the implementation of controls that are more appropriate for the site’s specific conditions.

**Step 1 – Determine Your Site’s Sediment Risk Level**

To meet the requirements of Alternative 2, you must first determine your site’s sediment discharge “risk level” based on the site’s slope, location, and soil type. To help you to determine your site’s sediment risk level, EPA developed five different tables for different slope conditions. You should select the table that most closely corresponds to your site’s average slope.

*For example, if your site’s average slope is 7 percent, you should use Table C-4 to determine your site’s sediment risk.*

After you determine which table applies to your site, you must then use the table to determine the “risk level” (e.g., “low”, “moderate”, or “high”) that corresponds to your site’s location and predominant soil type.<sup>41</sup>

*For example, based on Table C-3, a site located in Northern Utah with a 4 percent average slope and with predominately sandy clay loam soils would fall into the “low” risk level.*

**Table A-2 Risk Levels for Sites with Average Slopes of ≤ 3 Percent**

Soil Type Location	Clay	Silty Clay Loam or Clay- Loam	Sand	Sandy Clay Loam, Loamy Sand or Silty Clay	Loam, Silt, Sandy Loam or Silt Loam
<b>Idaho (Northern Utah)</b>	Low	Low	Low	Low	Low
<b>New Mexico (Southern Utah)</b>	Low	Low	Low	Low	Low

**Table A-3 Risk Levels for Sites with Average Slopes of > 3 Percent and ≤ 6 Percent**

Soil Type Location	Clay	Silty Clay Loam or Clay- Loam	Sand	Sandy Clay Loam, Loamy Sand or Silty Clay	Loam, Silt, Sandy Loam or Silt Loam
<b>Idaho (Northern Utah)</b>	Low	Low	Low	Low	Low
<b>New Mexico (Southern Utah)</b>	Low	Low	Low	Low	Moderate

<sup>41</sup> One source for determining your site’s predominant soil type is the USDA’s Web Soil Survey located at <http://websoilsurvey.nrcs.usda.gov/app/WebSoilSurvey.aspx>.



**Table A-4 Risk Levels for Sites with Average Slopes of > 6 Percent and ≤ 9 Percent**

Soil Type Location	Clay	Silty Loam or Clay-Loam	Sand	Sandy Clay Loam, Loamy Sand or Silty Clay	Loam, Silt, Sandy Loam or Silt Loam
Idaho (Northern Utah)	Low	Low	Low	Low	Low
New Mexico (Southern Utah)	Low	Low	Low	Low	Moderate

**Table A-5 Risk Levels for Sites with Average Slopes of > 9 Percent and ≤ 15 Percent**

Soil Type Location	Clay	Silty Loam or Clay-Loam	Sand	Sandy Clay Loam, Loamy Sand or Silty Clay	Loam, Silt, Sandy Loam or Silt Loam
Idaho (Northern Utah)	Low	Low	Low	Low	Low
New Mexico (Southern Utah)	Low	Moderate	Low	Moderate	Moderate

**Table A-6 Risk Levels for Sites with Average Slopes of > 15 Percent**

Soil Type Location	Clay	Silty Loam or Clay-Loam	Sand	Sandy Clay Loam, Loamy Sand or Silty Clay	Loam, Silt, Sandy Loam or Silt Loam
Idaho (Northern Utah)	Low	Low	Low	Low	Moderate
New Mexico (Southern Utah)	Moderate	Moderate	Moderate	Moderate	High

**Step 2 – Determine Which Additional Controls Apply**

Once you determine your site’s “risk level”, you must next determine the additional controls you need to implement on your site, based on the width of buffer you plan to retain. Table A-7

specifies the requirements that apply based on the “risk level” and buffer width retained. See footnote 40, above, for a description of the additional controls that are required.

*For example, if you are the operator of a small residential lot that falls into the “moderate” risk level, and you decide to retain a 20-foot buffer, using Table A-7 you would determine that you need to implement double perimeter controls to achieve compliance with small residential lot compliance alternative 2.*

You must also document in your SWPPP your compliance with small residential lot compliance alternative 2.

Table A-7. Alternative 2 Requirements

Risk Level Based on Estimated Soil Erosion	Retain ≥ 50' Buffer	Retain <50' and >30' Buffer	Retain ≤30' and >10' Buffer	Retain ≤ 10' Buffer
<b>Low Risk</b>	No Additional Requirements	No Additional Requirements	Double Perimeter Control	Double Perimeter Control
<b>Moderate Risk</b>	No Additional Requirements	Double Perimeter Control	Double Perimeter Control	Double Perimeter Control and 7-Day Site Stabilization
<b>High Risk</b>	No Additional Requirements	Double Perimeter Control	Double Perimeter Control and 7-Day Site Stabilization	Double Perimeter Control and 7-Day Site Stabilization

ATTACHMENT 1

Sediment Removal Efficiency Tables<sup>42</sup>

EPA recognizes that very high removal efficiencies, even where theoretically achievable by a 50-foot buffer, may be very difficult to achieve in practice using alternative controls. Therefore in the tables below, EPA has limited the removal efficiencies to a maximum of 90%. Efficiencies that were calculated at greater than 90% are shown as 90%, and this is the minimum percent removal that must be achieved by alternative controls.

For the Utah CGP only the tables for Idaho and New Mexico are shown. The table for Idaho substitutes for northern Utah and the table for New Mexico substitutes for southern Utah.

Table A-8 Estimated 50-foot Buffer Performance in Idaho\* (Northern Utah)

Type of Buffer Vegetation**	Estimated % Sediment Removal				
	Clay	Silty Clay Loam or Clay-Loam	Sand	Sandy Clay Loam, Loamy Sand or Silty Clay	Loam, Silt, Sandy Loam or Silt Loam
Tall Fescue Grass	42	52	44	48	85
Medium-density Weeds	28	30	28	26	60
Low-density Warm-season Native Bunchgrass (i.e., Grama Grass)	25	26	24	24	55
Northern Mixed Prairie Grass	28	30	28	26	50
Northern Range Cold Desert Shrubs	28	28	24	26	50

\* Applicable for sites with less than nine percent slope

\*\* Characterization focuses on the under-story vegetation

Table A-9 Estimated 50-foot Buffer Performance in New Mexico\* (Southern Utah)

Type of Buffer Vegetation **	Estimated % Sediment Removal				
	Clay	Silty Clay Loam or Clay-Loam	Sand	Sandy Clay Loam, Loamy Sand or Silty Clay	Loam, Silt, Sandy Loam or Silt Loam
Tall Fescue grass	71	85	80	86	90

<sup>42</sup> The buffer performances were calculated based on a denuded slope upgradient of a 50-foot buffer and a perimeter controls, as perimeter controls are a standard requirement (see Part 2.2.3).



**CONSTRUCTION GENERAL STORM WATER PERMIT (CGP)**

---

Medium-density Weeds	56	73	55	66	78
Low-density Warm-season Native Bunchgrass (i.e., Grama Grass)	53	70	51	62	67
Southern Mixed Prairie Grass	53	71	52	63	50
Southern Range Cold Desert Shrubs	56	73	55	65	53

\* Applicable for sites with less than nine percent slope

\*\* Characterization focuses on the under-story vegetation

ATTACHMENT 2

Using the Sediment Removal Efficiency Tables – Questions and Answers

– **What if my specific buffer vegetation is not represented in Tables A-8 and A-9?** Tables A-8 and A-9 provide a range of factors affecting buffer performance; however, there are likely instances where the specific buffer vegetation type on your site is not listed. If you do not see a description of the type of vegetation present at your site, you should choose the vegetation type that most closely matches the vegetation type on your site. You can contact your local Cooperative Extension Service Office (<http://nifa.usda.gov/partners-and-extension-map>) for assistance in determining the vegetation type in Tables C-8 through C-9 that most closely matches your site-specific vegetation.

– **What if there is high variability in local soils?** EPA recognizes that there may be a number of different soil type(s) on any given construction site. General soil information can be obtained from USDA soil survey reports (<http://websoilsurvey.nrcs.usda.gov>) or from individual site assessments performed by a certified soil expert. Tables A-8 and A-9 present eleven generic soil texture classes, grouping individual textures where EPA has determined that performance is similar. If your site contains different soil texture classes, you should use the soil type that best approximates the predominant soil type at your site.

– **What if my site slope is greater than 9 percent after final grade is reached?** As indicated in the buffer performance tables, the estimated sediment removal efficiencies are associated with disturbed slopes of up to 9 percent grade. Where your graded site has an average slope of greater than 9 percent, you should calculate a site-specific buffer performance.

– **How do I calculate my own estimates for sediment reduction at my specific site?** If you determine that it is necessary to calculate your own sediment removal efficiency using site-specific conditions (e.g., slopes at your site are greater than 9 percent), you can use a range of available models that are available to facilitate this calculation, including USDA's RUSLE- series programs and the WEPP erosion model, SEDCAD, SEDIMOT, or other equivalent models.

– **What is my estimated buffer performance if my site location is not represented by Tables A-8 and A-9?** If your site is located in an area not represented by Tables A-8 and A-9, you should use the table that most closely approximates conditions at your site (Table A-8 generally represents northern Utah, Table A-9 generally represents southern Utah). You may instead choose to conduct a site-specific calculation of the buffer performance.

– **What if only a portion of my site drains to the buffer area?** If only a portion of your site drains to a water of the State, where that water is within 50 feet of your earth disturbances, you are only required to meet the equivalency requirement for the storm water flows corresponding to those portions of the site. See Attachment 3 for an example of how this is expected to work.

**ATTACHMENT 3**

Example of How to Use the Sediment Removal Efficiency Tables

Arid Location With Pre-existing Disturbances in the Natural Buffer (6.5 acre site located in southern Utah)

An operator of a site in southern Utah determines that it is not feasible to provide a 50-foot buffer, but a 28-foot buffer can be provided. Because the operator will provide a buffer that is less than 50 feet, the operator must determine which controls, in combination with the 28-foot buffer, achieve a sediment load reduction equivalent to the 50-foot buffer. In this example, the project will disturb 6.5 acres of land, but only 1.5 acres of the total disturbed area drains to the buffer area. Within the 28-foot buffer area is a preexisting concrete walkway. The equivalence analysis starts with Step 1 in Part A.2.4 of this Appendix with a review of the southern Utah buffer performance (Table A-9). The operator determines that the predominate vegetation type in the buffer area is prairie grass, the soil type is similar to silt, and the site is of a uniform, shallow slope (e.g., 3 percent grade). Although the operator will take credit for the disturbance caused by the concrete walkway as a natural buffer in Step 2, here the operator can treat the entire buffer area as being naturally vegetated with prairie grass. Based on this information, the operator refers to Table A-9 to estimate that the 50-foot buffer would retain 50 percent of eroded soil.

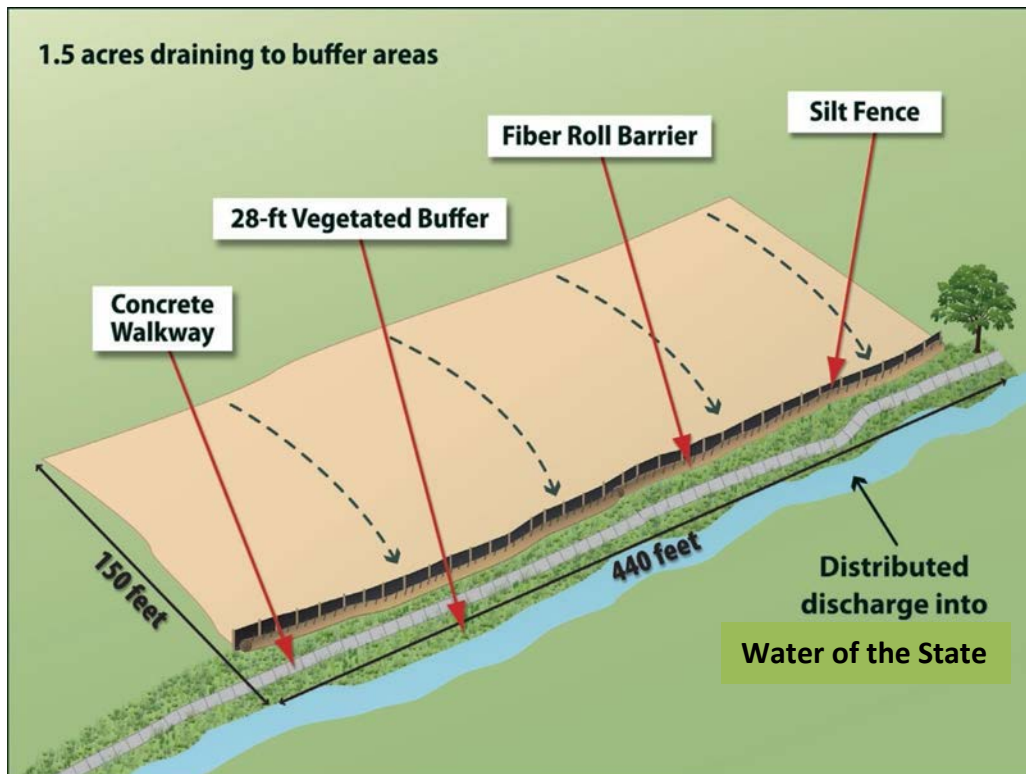

Figure A-5 Example – Equivalent Sediment Load Reductions at a 6.5 ac Site in Southern Utah.

The second step is to determine, based on the 50 percent sediment removal efficiency found in Table A-9, what sediment controls, in combination with the 28-foot buffer area, can be implemented to reduce

sediment loads by 50 percent or more. The operator does not have to account the reduction in buffer function caused by the preexisting walkway, and can take credit for the entire 28-foot buffer being fully vegetated in the analysis. For this example, using the RUSLE2 profile model, the operator determined that installing a fiber roll barrier between the silt fence (already required by Part 2.2.3) and the 28-foot buffer will achieve an estimated 84 percent sediment removal efficiency. See Figure A-5. Note that this operator is subject to the requirement in Part A.2.3 of this Appendix to ensure that discharges through the silt fence, fiber roll barrier, and 28-foot buffer do not cause erosion within the buffer. The estimated sediment reduction is greater than the required 50 percent; therefore the operator will have met the buffer alternative requirement.