

LOT AREAS

LOT #	AREA	LOT #	AREA
LOT 1	16,097.40 SQ FT (0.37 ACRES)	LOT 13	11,474.95 SQ FT (0.26 ACRES)
LOT 2	34,648.33 SQ FT (0.80 ACRES)	LOT 14	10,662.21 SQ FT (0.25 ACRES)
LOT 3	13,950.94 SQ FT (0.32 ACRES)	LOT 15	10,662.92 SQ FT (0.25 ACRES)
LOT 4	12,349.75 SQ FT (0.28 ACRES)	LOT 16	10,663.60 SQ FT (0.25 ACRES)
LOT 5	12,348.80 SQ FT (0.28 ACRES)	LOT 17	10,664.33 SQ FT (0.25 ACRES)
LOT 6	12,825.42 SQ FT (0.29 ACRES)	LOT 18	10,665.04 SQ FT (0.25 ACRES)
LOT 7	13,160.3 SQ FT (0.30 ACRES)	LOT 19	10,665.74 SQ FT (0.25 ACRES)
LOT 8	13,196.17 SQ FT (0.30 ACRES)	LOT 20	10,666.45 SQ FT (0.25 ACRES)
LOT 9	13,196.17 SQ FT (0.30 ACRES)	LOT 21	10,662.80 SQ FT (0.25 ACRES)
LOT 10	13,196.17 SQ FT (0.30 ACRES)	LOT 22	11,095.40 SQ FT (0.26 ACRES)
LOT 11	13,170.00 SQ FT (0.30 ACRES)	LOT 23	11,335.69 SQ FT (0.26 ACRES)
LOT 12	13,205.30 SQ FT (0.30 ACRES)	LOT 24	11,336.49 SQ FT (0.26 ACRES)
		LOT 25	16,316.97 SQ FT (0.37 ACRES)

TYP. PUE & SETBACKS

PROPERTY ZONE: R-1-6

FRONT SETBACK	30.0 FT
SIDE SETBACK	12.0 FT
REAR SETBACK	30.0 FT
CORNER SIDE SETBACK	30.0 FT
FRONT PUE & DE	10 FT

LAND USE TABLE

TOTAL GROSS ACREAGE (ACRES)	435,947 SQ FT (10.00 ACRES)
MINIMUM LOT SIZE (ACRES)	14,000 SQ FT (0.32 ACRES)
TOTAL NUMBER OF LOTS	25 LOTS
RIGHT OF WAY AREA (ACRES)	103,230 SQ FT (2.37 ACRES)

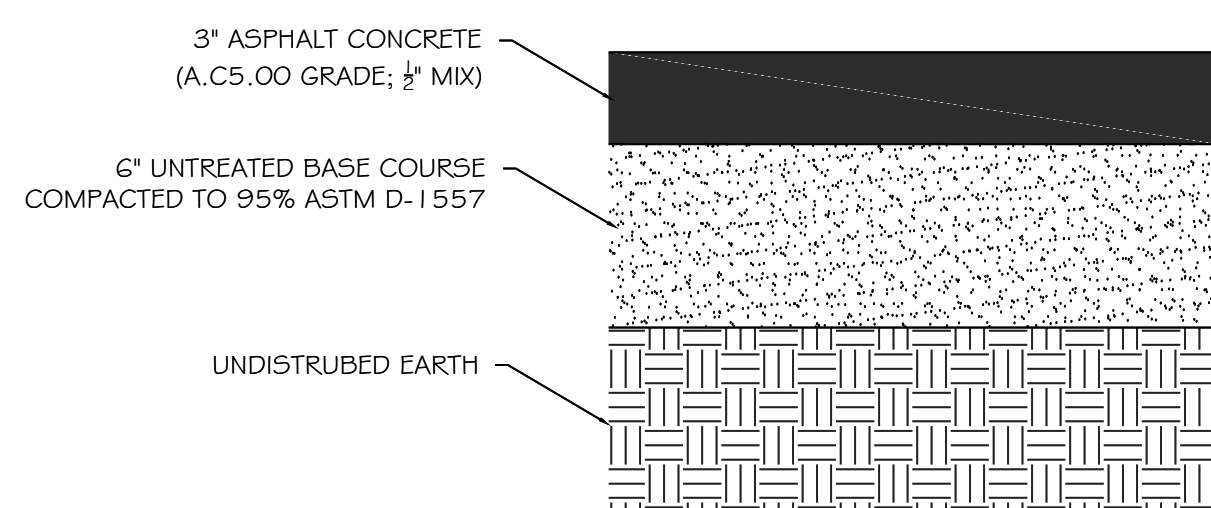
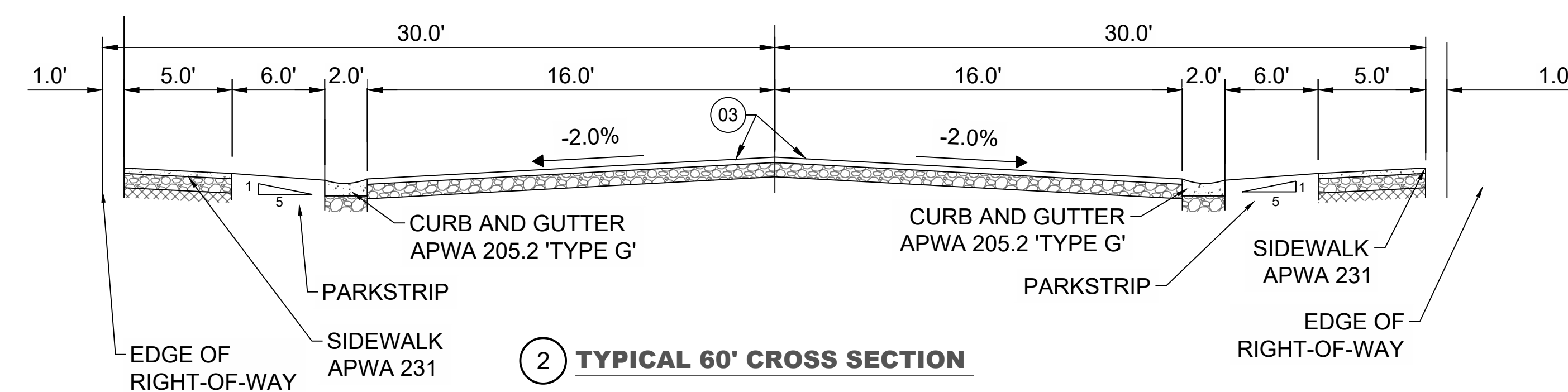
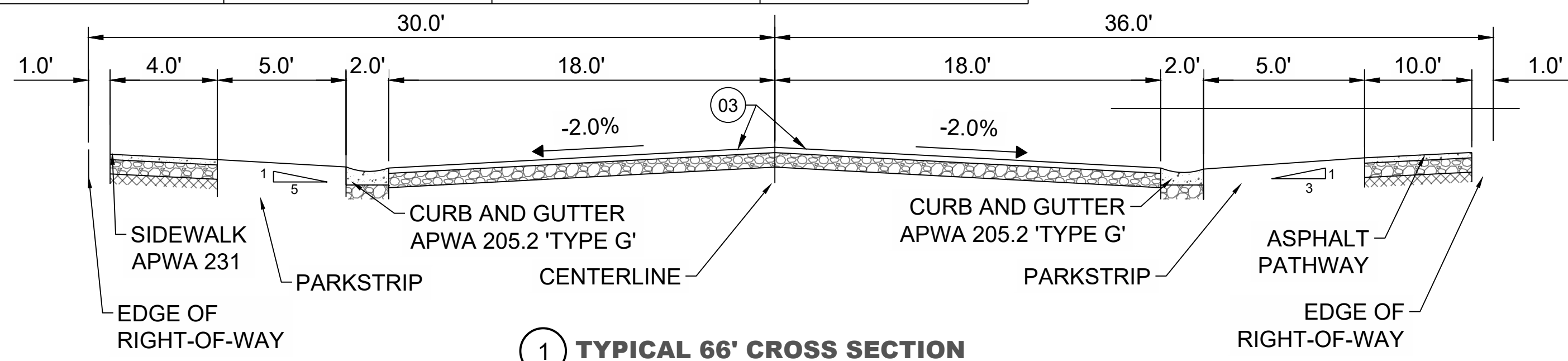

2 PAVEMENT SECTION SCALE: NONE

CENTER OF SECTION 29, TOWNSHIP 6 NORTH, RANGE 2 WEST, SALT LAKE BASE AND MERIDIAN, U.S. SURVEY. FOUND WEBER COUNTY SURVEY BRASS CAP MONUMENT 5' BELOW GROUND

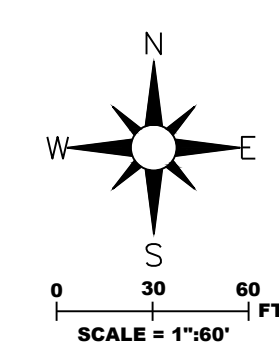
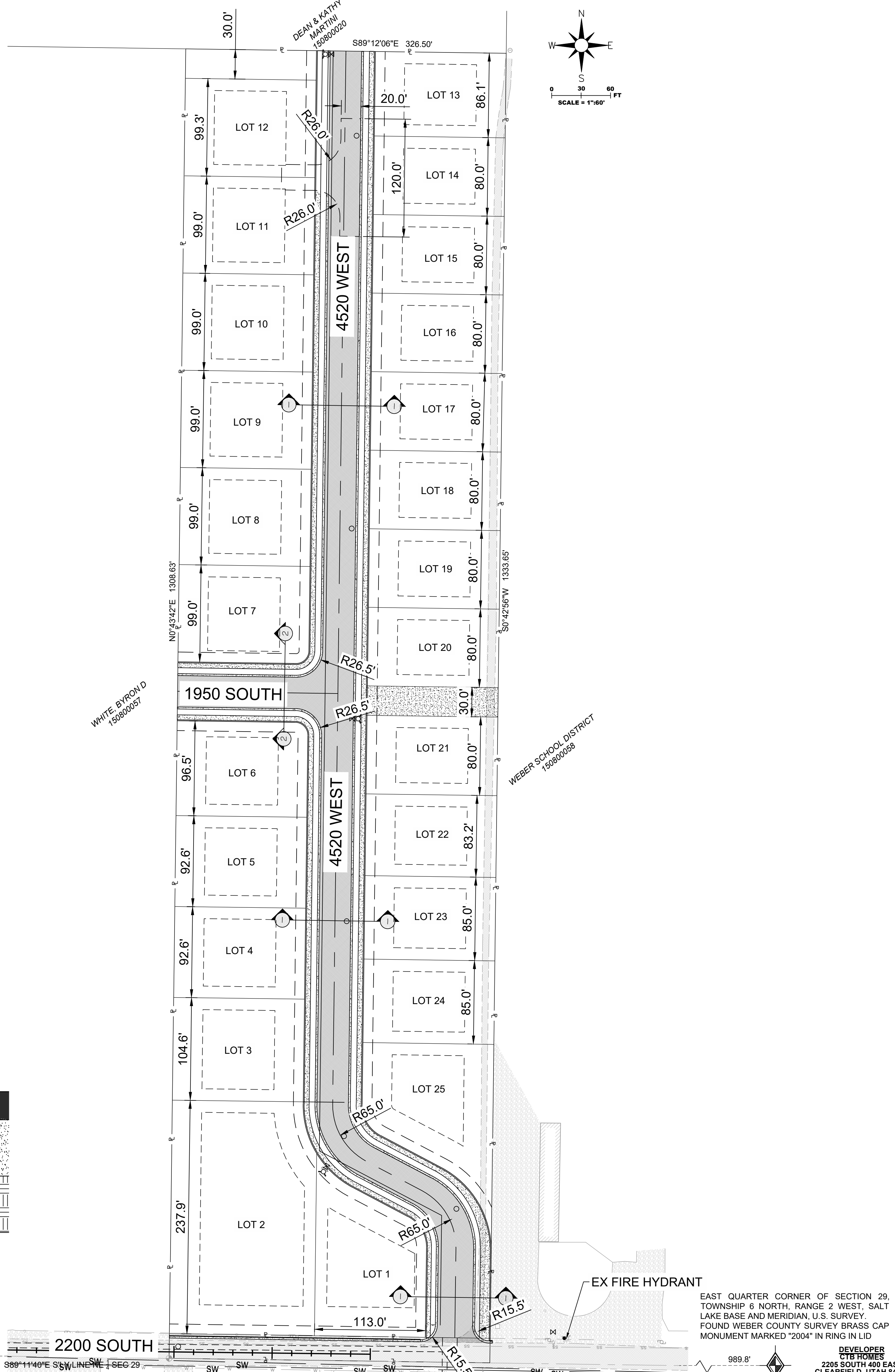

CAUTION: NOTICE TO CONTRACTOR

THE CONTRACTOR IS SPECIFICALLY CAUTIONED THAT THE LOCATION AND/OR ELEVATION OF EXISTING UTILITIES AS SHOWN ON THESE PLANS IS BASED ON RECORDS OF THE VARIOUS UTILITY COMPANIES AND, WHERE POSSIBLE, MEASUREMENTS TAKEN IN THE FIELD. THE INFORMATION IS NOT TO BE RELIED ON AS BEING EXACT OR COMPLETE. THE CONTRACTOR MUST CALL THE LOCAL UTILITY LOCATION CENTER AT LEAST 48 HOURS BEFORE ANY EXCAVATION TO REQUEST EXACT FIELD LOCATIONS OF THE UTILITIES. IT SHALL BE THE RESPONSIBILITY OF THE CONTRACTOR TO RELOCATE ALL EXISTING UTILITIES WHICH CONFLICT WITH THE PROPOSED IMPROVEMENTS SHOWN ON THE PLANS. IF A CONFLICT IS IDENTIFIED, THE ENGINEER OF RECORD SHOULD BE CONTACTED IMMEDIATELY, PRIOR TO ANY FURTHER WORK BEING DONE RELATED TO THE ISSUE. CONTRACTOR IS TO BEGIN CONSTRUCTION AT LOW SIDE OF ALL GRAVITY LINES.

Know what's below. 811
Call 811 before you dig.
 BLUE STAKES OF UTAH
 UTILITY NOTIFICATION CENTER, INC.
 www.bluestakes.org
 1-800-662-4111

THE CONTRACTOR IS TO CALL BLUE STAKES PRIOR TO ANY CONSTRUCTION.



1246 E Driggs Ave
 SLC, UT 84106
 isaac@irecivil.com (801) 860-2191

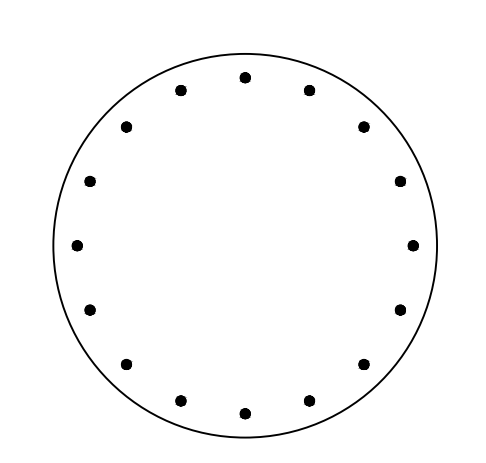

SINGLETREE ACRES SUBDIVISION
 4520 WEST 2200 SOUTH
 TAYLOR TOWNSHIP, WEBER COUNTY, UTAH 84401

CLIENT CONTACT
 NAME: CHAD BUCK
 ADDRESS: 2205 SOUTH 400 EAST
 CLEARFIELD, UTAH 84015
 PHONE: (801) 725-3511
 EMAIL: CTBHOMES19@GMAIL.COM

REV	COMMENT

SHEET NO.
C200
 CONCEPT PLAN

DEVELOPER
 CTBHOMES
 2205 SOUTH 400 EAST
 CLEARFIELD, UTAH 84015
 801-725-3511