

**VICINITY MAP**  
SCALE: NONE

**BOUNDARY DESCRIPTION  
(FOR PHASES 2-22)**

ALL OF SECTION 11, TOWNSHIP 6 NORTH, RANGE 2 EAST, SALT LAKE BASE AND MERIDIAN, U.S. SURVEY. MORE PARTICULARLY DESCRIBED AS FOLLOWS:

BEGINNING AT A POINT, SAID POINT BEING 1285.91 FEET SOUTH 89°54'27" EAST AND 336.88 FEET NORTH 00°05'33" EAST FROM THE SOUTHWEST CORNER OF SAID SECTION 11; THENCE NORTH 01°08'59" WEST 436.98 FEET; THENCE WEST 498.37 FEET; THENCE NORTH 4453.04 FEET; THENCE NORTH 89°33'08" EAST 1980.62 FEET; THENCE NORTH 89°51'57" EAST 2631.81 FEET; THENCE SOUTH 00°09'20" EAST 2613.50 FEET; THENCE WEST 911.71 FEET; THENCE SOUTH 06°32'14" EAST 843.75 FEET; THENCE WEST 582.31 FEET; THENCE SOUTH 54°12'24" WEST 781.91 FEET; THENCE SOUTH 43°57'42" WEST 657.08 FEET; THENCE SOUTH 83°35'56" WEST 926.47 FEET; THENCE ALONG A NON-TANGENT CURVE TURNING TO THE LEFT WITH A RADIUS OF 117.00 FEET, AN ARC LENGTH OF 2.02 FEET, A DELTA ANGLE OF 00°59'25", A CHORD BEARING OF SOUTH 26°24'35" EAST, AND A CHORD LENGTH OF 2.02 FEET; THENCE SOUTH 26°54'18" EAST 257.10 FEET; THENCE ALONG A NON-TANGENT CURVE TURNING TO THE RIGHT WITH A RADIUS OF 182.34 FEET, AN ARC LENGTH OF 166.73 FEET, A DELTA ANGLE OF 52°23'28", A CHORD BEARING OF SOUTH 00°48'41" EAST, AND A CHORD LENGTH OF 160.98 FEET; THENCE SOUTH 25°16'56" WEST 68.98 FEET; THENCE NORTH 64°43'04" WEST 66.00 FEET; THENCE WEST 733.68 FEET TO THE POINT OF BEGINNING.

CONTAINING 1,812,8714 SQUARE FEET OR 416.178 ACRES.

**LEGEND**

- = SECTION CORNER
- = BOUNDARY LINE/PHASE LINE
- = LOT LINE
- = ADJOINING PROPERTY
- = ROAD CENTERLINE
- = EASEMENTS
- = SECTION TIE LINE
- = SEASONAL DRAINAGE STREAM
- = 100' SEASONAL DRAINAGE PROTECTION ZONE

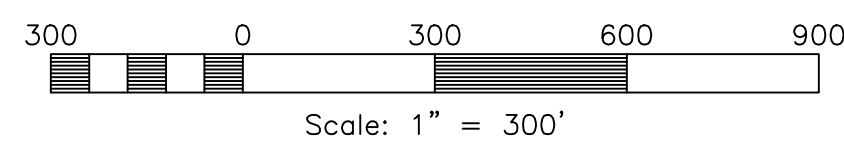

**CURVE TABLE**

CURVE	RADIUS	ARC	LTH	CHD	LTH	CHD	BEARING	DELTA
C1	117.00'	2.02'	2.02'	S26°24'35"E	0°59'25"			
C2	183.00'	166.68'	160.98'	S00°48'41"E	52°11'14"			

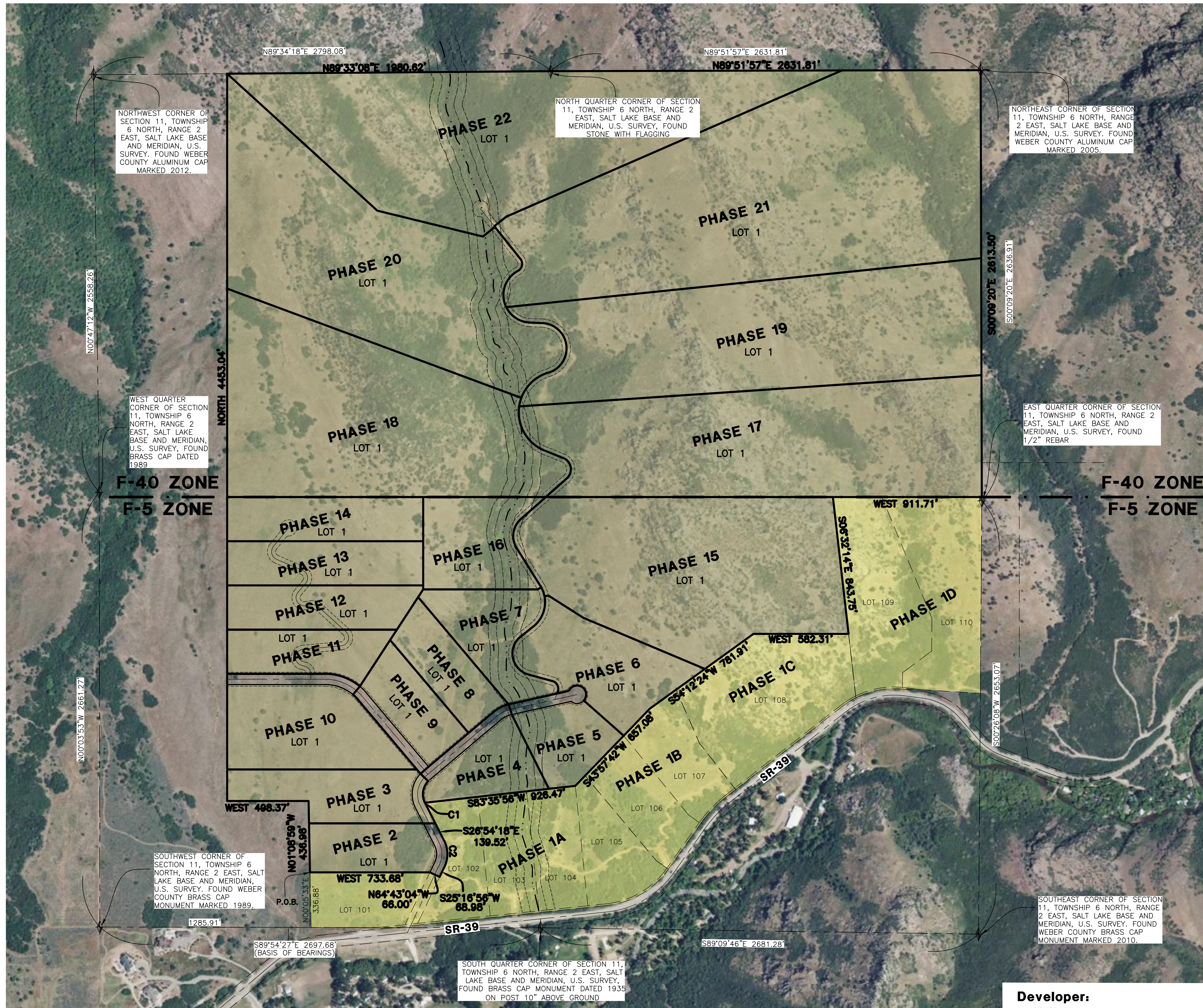

**Gateway Estates Subdivision**

Weber County, Utah

**Developer:**

Matt Lowe  
6028 S. Ridgeline Dr., Ste. 200  
Ogden, UT. 84405  
(801) 648-8229

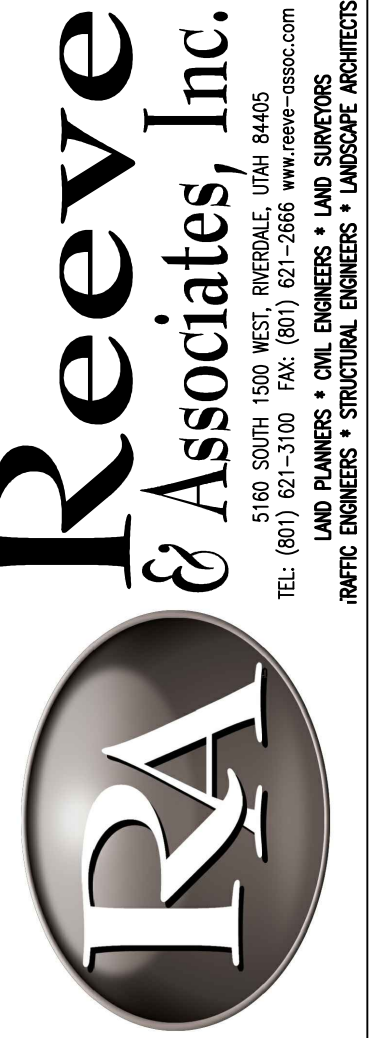

**REVISIONS**

DATE	DESCRIPTION
4-22-21	1.0 REVISIONS
6-17-21	ROAD REVISION
4-26-23	SEPARATE PHASES

**Gateway Estates Subdivision**  
ALL OF SECTION 11, T.6N., R.2E., S.L.B. & M., U.S. SURVEY  
WEBER COUNTY, UTAH

**Preliminary Plan**

**Project Info.**  
Engineer: N. Reeve  
Designer: C. Cove  
Begin Date: 4-18-23  
Name: GATEWAY ESTATES SUBDIVISION  
Number: 4825-26



MATCH LINE  
SEE SHEET 3

MATCH LINE  
SEE SHEET 3

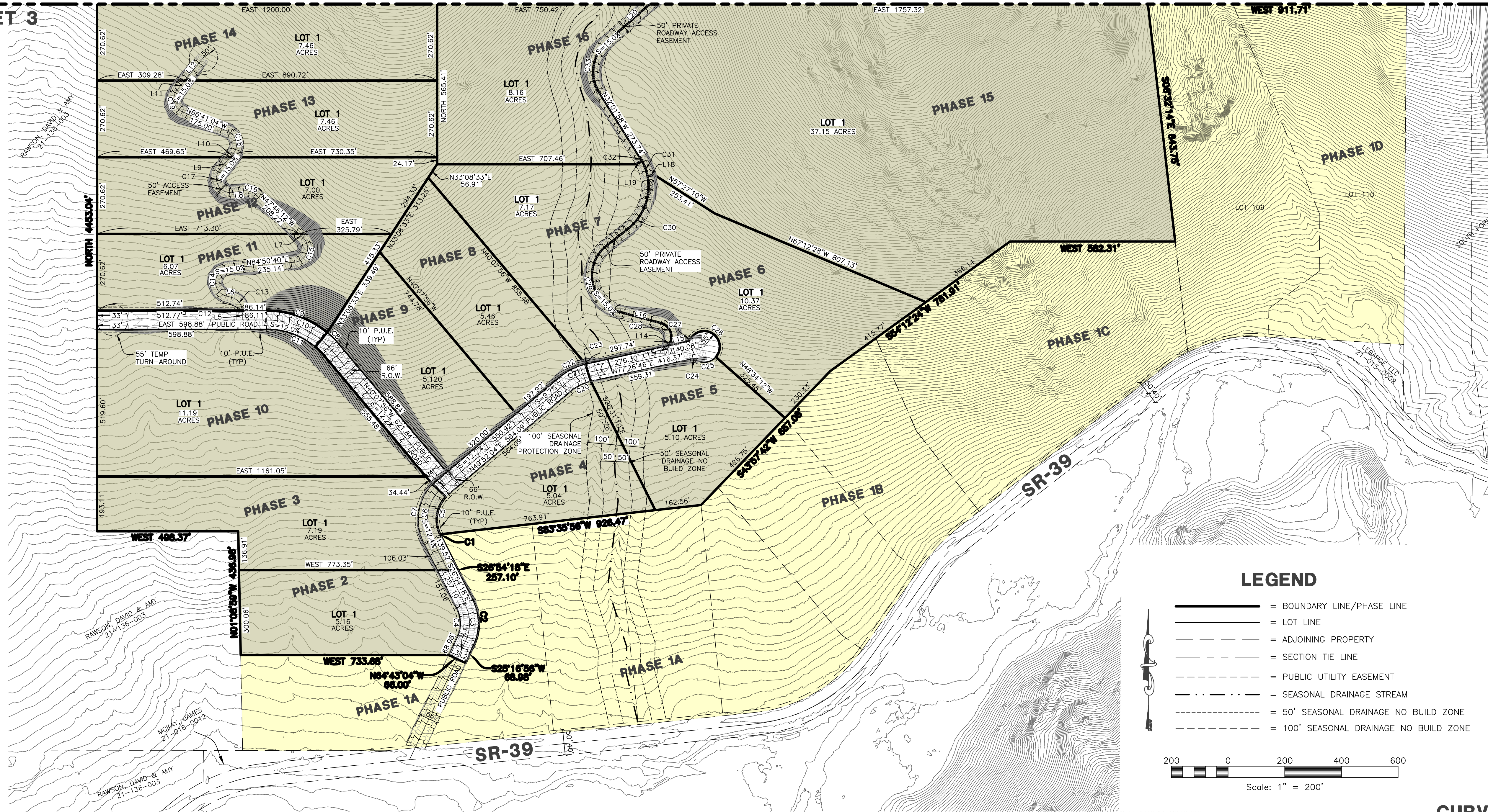

**LEGEND**

- = BOUNDARY LINE/PHASE LINE
- = LOT LINE
- = ADJOINING PROPERTY
- - - = SECTION TIE LINE
- - - = PUBLIC UTILITY EASEMENT
- - - = SEASONAL DRAINAGE STREAM
- - - = 50' SEASONAL DRAINAGE NO BUILD ZONE
- - - = 100' SEASONAL DRAINAGE NO BUILD ZONE

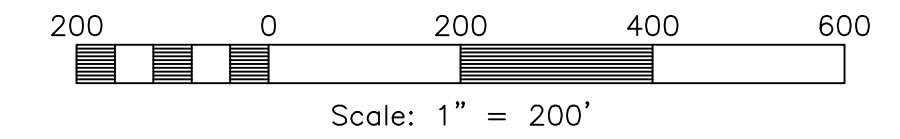

**CURVE TABLE**

CURVE	RADIUS	ARC LTH	CHD LTH	CHD BEARING	DELTA
C1	117.00	2.02	2.02	S26°24'35"E	0°59'25"
C2	183.00	166.68	160.98	S00°48'41"E	52°11'14"
C3	150.00	136.63	131.95	N00°48'41"W	52°11'14"
C4	117.00	106.57	102.92	N00°48'41"W	52°11'14"
C5	117.00	154.75	143.71	N11°58'35"E	75°46'57"
C6	150.00	200.99	186.29	N11°28'53"E	76°46'21"
C7	183.00	225.34	211.37	N08°22'14"E	70°33'03"
C8	333.00	58.54	58.46	N45°10'07"W	10°04'21"
C9	333.00	231.29	226.67	N70°06'06"W	39°47'43"
C10	300.00	261.11	252.94	N65°03'58"W	49°52'04"
C11	267.00	232.32	225.06	N65°04'23"W	49°51'13"
C12	50.00	1.53	1.53	N00°52'44"W	1°45'27"
C13	50.00	64.48	60.10	N38°42'W	73°53'06"
C14	50.00	140.05	98.55	N04°36'03"E	160°29'14"
C15	50.00	115.73	91.57	N18°32'14"E	132°36'52"
C16	50.00	44.68	43.21	N73°22'19"W	51°12'14"
C17	50.00	121.56	93.76	N29°19'28"W	139°17'56"
C18	50.00	93.58	80.39	N13°10'47"W	107°00'34"
C19	50.00	92.44	79.82	N13°43'18"W	105°55'33"
C20	167.00	80.38	79.61	N63°39'25"E	27°34'42"
C21	200.00	96.27	95.34	N63°39'25"E	27°34'42"
C22	233.00	105.66	104.76	N62°51'33"E	25°58'58"
C23	233.00	6.49	6.49	N76°58'54"E	1°35'44"
C24	30.00	22.08	21.58	S81°28'12"E	42°10'06"
C25	55.00	75.05	69.36	N80°31'20"E	78°11'03"
C26	55.00	178.69	109.84	N51°38'46"W	186°09'09"
C27	30.00	22.08	21.58	S56°21'43"W	42°10'06"
C28	50.00	83.18	73.91	N27°11'36"W	95°18'54"
C29	133.00	293.00	237.24	N11°44'21"W	126°13'25"
C30	190.00	206.64	196.61	N20°12'55"E	62°18'54"
C31	190.00	58.32	58.09	N19°44'11"W	17°35'16"
C32	190.00	11.61	11.61	N30°16'53"W	3°30'09"
C33	137.00	192.40	176.98	N08°12'02"E	80°28'01"
C34	75.00	152.55	127.58	N09°50'09"W	116°32'22"

**LINE TABLE**

#	BEARING	DISTANCE
L1	N25°16'56"E	68.98'
L2	N64°43'04"W	33.00'
L3	N64°43'04"W	33.00'
L4	N49°52'04"E	13.17'
L5	NORTH	31.47'
L6	N75°38'33"W	19.78'
L7	N47°46'12"W	18.78'
L8	S81°01'34"W	38.79'
L9	N40°19'30"E	55.90'
L10	N40°19'30"E	17.12'
L11	N39°14'29"E	41.94'
L12	N39°14'29"E	105.30'
L13	N20°27'51"E	39.36'
L14	N20°27'51"E	11.87'
L15	S77°26'46"W	61.57'
L16	N74°51'03"W	150.01'
L17	N51°22'22"E	99.65'
L18	N79°03'28"E	25.00'
L19	S61°28'11"W	25.00'
L20	N48°26'03"E	205.29'

**NOTES**

1. CONTOURS ARE SHOWN IN 5 FOOT INTERVALS
2. LOTS WILL HAVE WELLS WITH A 100' RADIUS PROTECTION ZONE
3. LOTS WILL HAVE SEPTIC TANKS
4. EACH INDIVIDUAL RESIDENTIAL HOME TO HAVE A FIRE SPRINKLER SYSTEM INSTALLED THAT IS DIRECTLY SUPPLIED BY THEIR WELL LOCATED ON EACH INDIVIDUAL LOT.

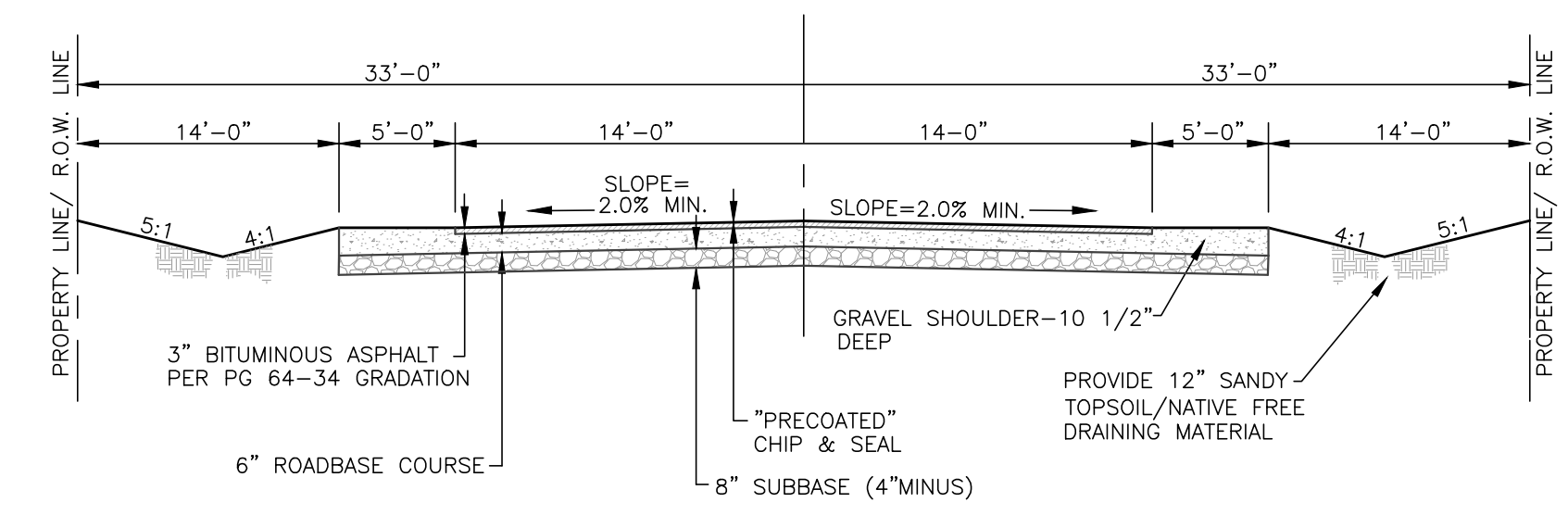
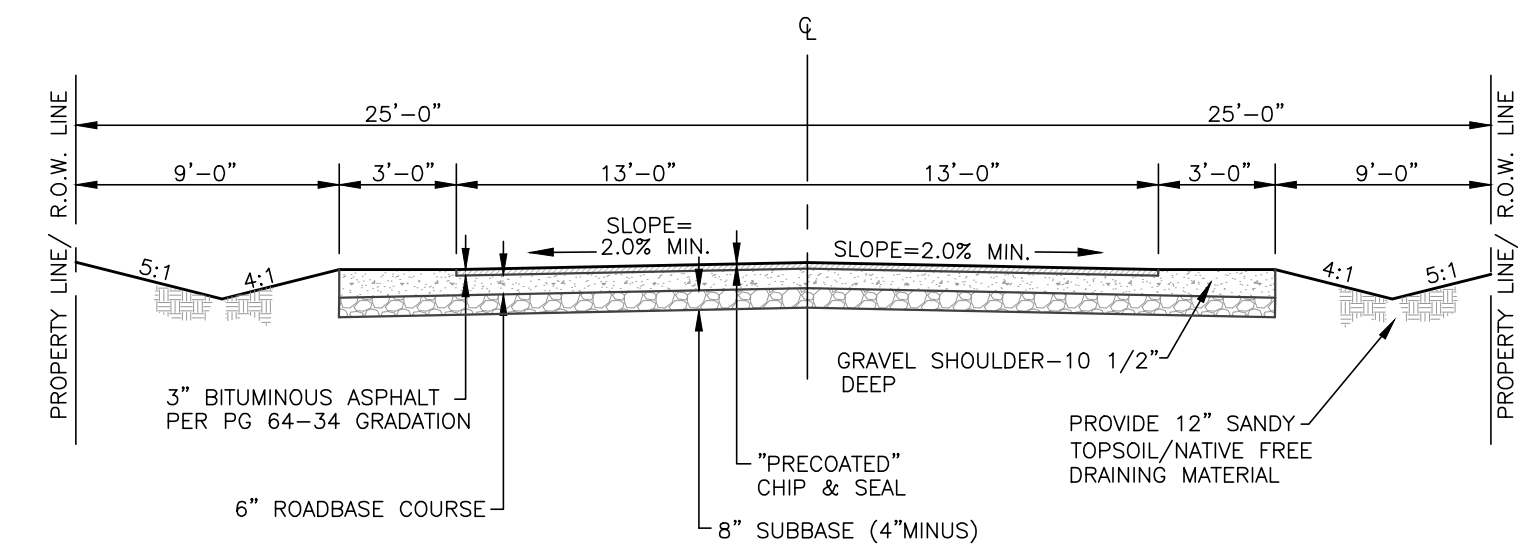

**PRIVATE ROADWAY SECTION (50' R.O.W.)**

**STREET SECTION (66' R.O.W.)**

**Gateway Estates Subdivision**

Weber County, Utah

**Reeve & Associates, Inc.**  
  
 5160 SOUTH 1500 WEST, RIVERDALE, UTAH 84405  
 TEL: (801) 821-3100 FAX: (801) 821-2668 www.reeve-assoc.com  
 LAND PLANNERS • CIVIL ENGINEERS • LAND SURVEYORS  
 ARCHITECTS • STRUCTURAL ENGINEERS

**REVISIONS**

DATE	DESCRIPTION
4-22-21	LOI REVISIONS
6-17-21	ROAD REVISION
4-26-23	SEPARATE PHASES

**Gateway Estates Subdivision**  
 ALL OF SECTION 11, T.6N., R.2E., S.L.B. & M., U.S. SURVEY  
 WEBER COUNTY, UTAH

**Preliminary Design**

**Project Info.**

Engineer:	N. Reeve
Designer:	C. Cave
Begin Date:	4-18-23
Name:	GATEWAY ESTATES SUBDIVISION
Number:	4825-26



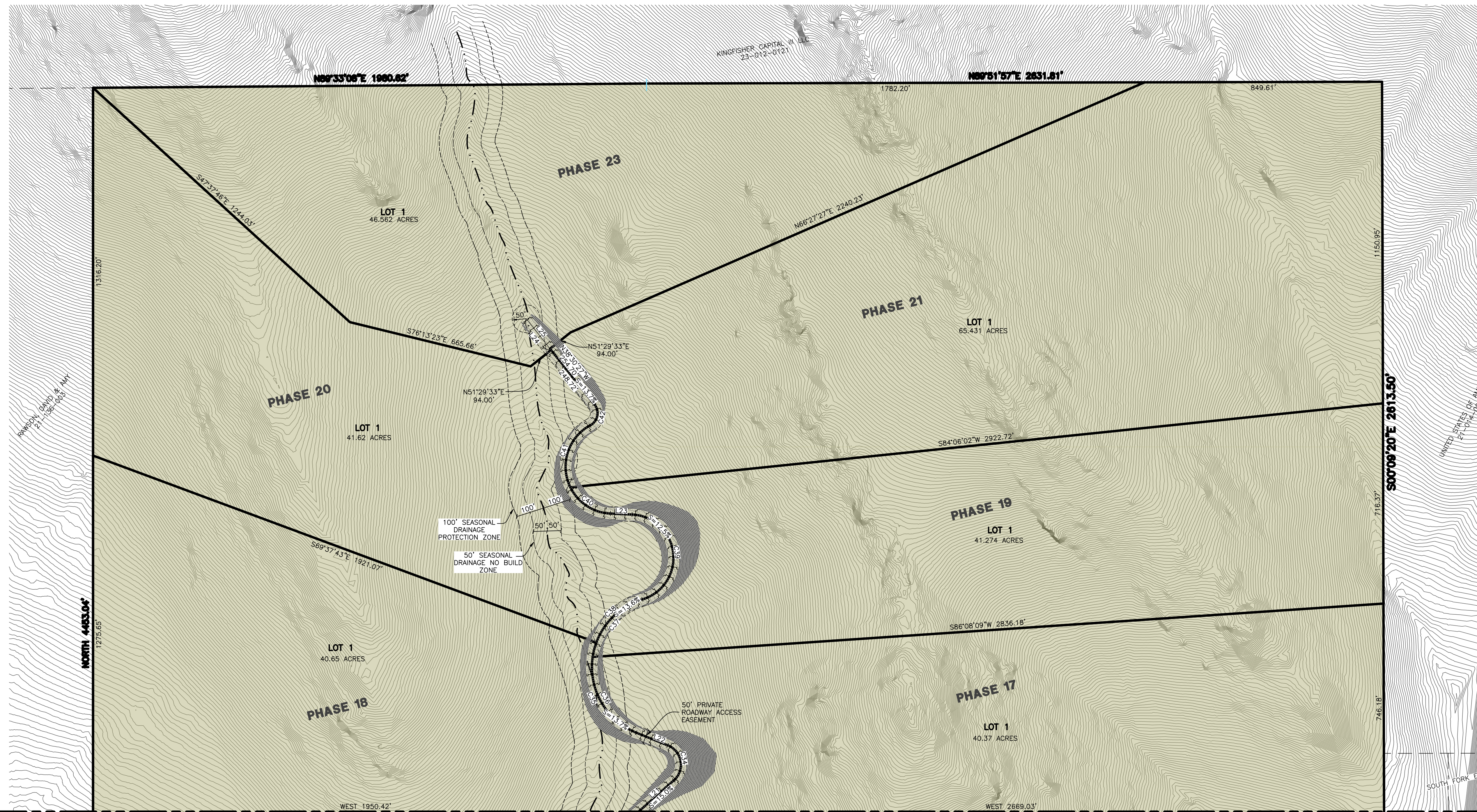

MATCH LINE  
SEE SHEET 2

MATCH LINE  
SEE SHEET 2

**LEGEND**

- = BOUNDARY LINE/PHASE LINE
- = LOT LINE
- = ADJOINING PROPERTY
- = SECTION TIE LINE
- = PUBLIC UTILITY EASEMENT
- = SEASONAL DRAINAGE STREAM
- = 50' SEASONAL DRAINAGE NO BUILD ZONE
- = 100' SEASONAL DRAINAGE NO BUILD ZONE

**NOTES**

1. CONTOURS ARE SHOWN IN 5 FOOT INTERVALS
2. LOTS WILL HAVE WELLS WITH A 100' RADIUS PROTECTION ZONE
3. LOTS WILL HAVE SEPTIC TANKS
4. EACH INDIVIDUAL RESIDENTIAL HOME TO HAVE A FIRE SPRINKLER SYSTEM INSTALLED THAT IS DIRECTLY SUPPLIED BY THEIR WELL LOCATED ON EACH INDIVIDUAL LOT.

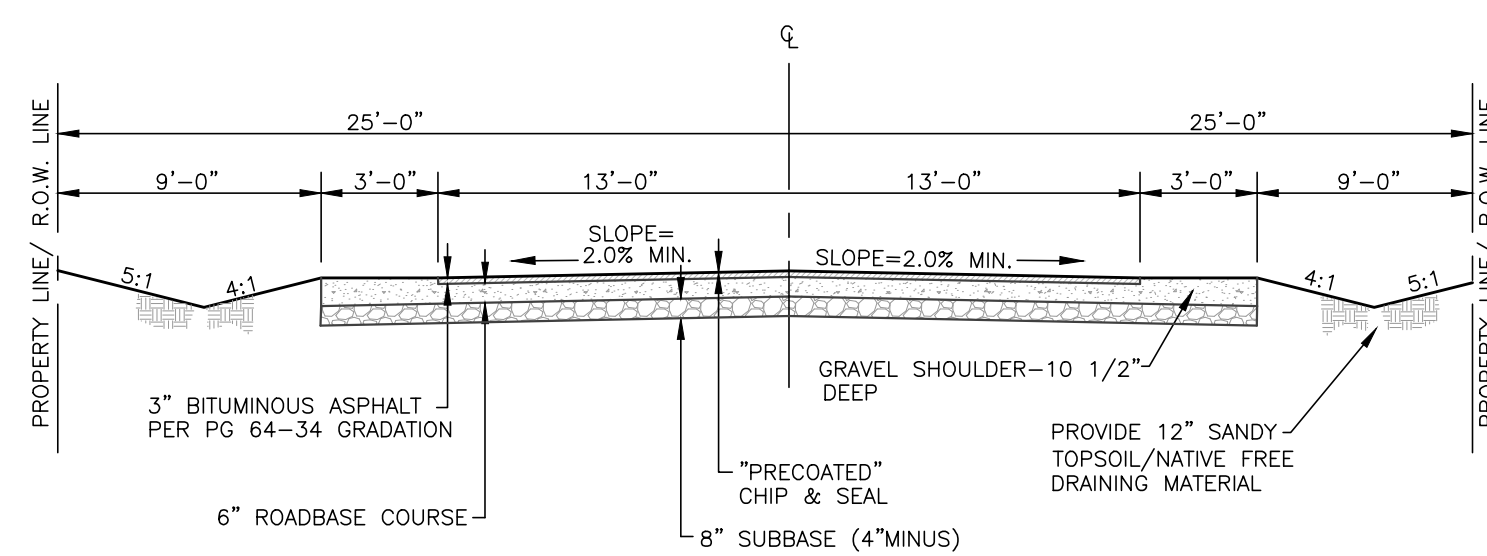
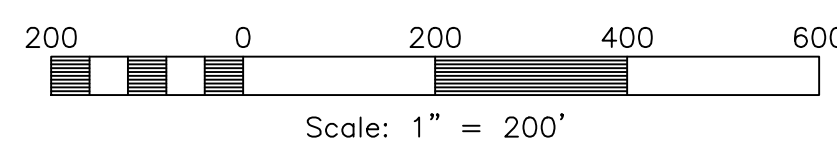

**PRIVATE ROADWAY SECTION (50' R.O.W.)**

SCALE: NONE

**LINE TABLE**

#	BEARING	DISTANCE
L21	N48°26'03"E	170.60'
L22	N68°06'20"W	121.26'
L23	N87°18'44"W	77.90'
L24	N38°30'27"W	143.31'
L25	N38°30'27"W	137.33'

**CURVE TABLE**

CURVE	RADIUS	ARC	LTH	CHD	LTH	CHD	BEARING	DELTA
C35	253.00'	390.67'	353.00'	N23°52'08"W	88°28'23"			
C36	253.00'	337.04'	312.66'	N29°56'30"W	76°19'40"			
C37	253.00'	287.90'	272.62'	N40°49'21"E	65°12'			
C38	253.00'	234.28'	226.00'	N46°53'44"E	53°03'23"			
C39	155.00'	434.83'	305.63'	N06°56'39"W	160°44'09"			
C40	168.00'	179.30'	170.91'	N56°44'13"W	61°09'01"			
C41	168.00'	256.11'	232.02'	N17°30'42"E	87°20'48"			
C42	50.01'	88.06'	77.12'	N11°56'25"E	100°52'58"			

**Gateway Estates Subdivision**

Weber County, Utah

**Reeve & Associates, Inc.**  
  
 5160 SOUTH 1500 WEST, RIVERDALE, UTAH 84405  
 TEL: (801) 821-3100 FAX: (801) 821-2668 www.reeve-assoc.com  
 LAND PLANNERS • CIVIL ENGINEERS • LAND SURVEYORS  
 ARCHITECTS • STRUCTURAL ENGINEERS • LANDSCAPE ARCHITECTS

**REVISIONS**

DATE	DESCRIPTION
4-22-21	1.0 REVISIONS
6-17-21	ROAD REVISION
4-26-23	SEPARATE PHASES

**Gateway Estates Subdivision**  
 ALL OF SECTION 11, T.6N., R.2E., S.L.B. & M., U.S. SURVEY  
 WEBER COUNTY, UTAH  
**Preliminary Design**

**Project Info.**  
 Engineer: N. Reeve  
 Designer: C. Cove  
 Begin Date: 4-18-23  
 Name: GATEWAY ESTATES SUBDIVISION  
 Number: 4825-26

Sheet **4**  
**3** Sheets



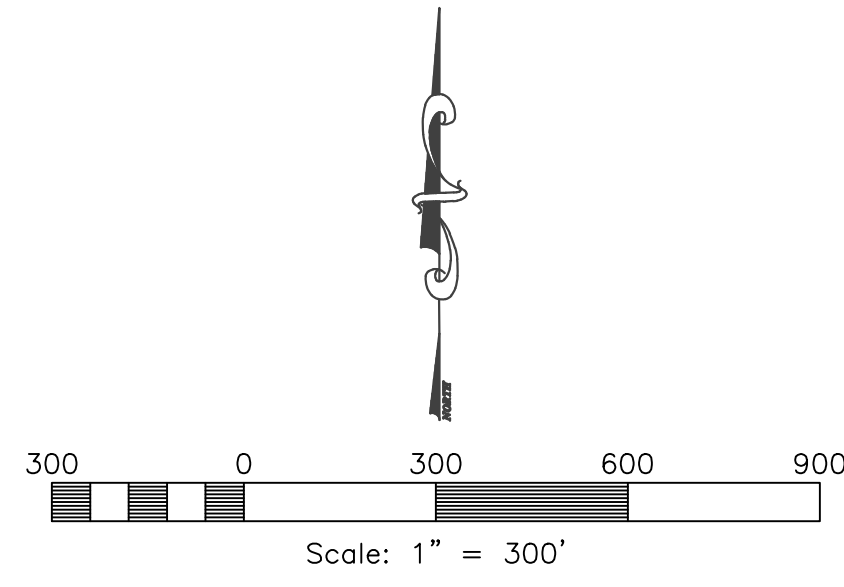
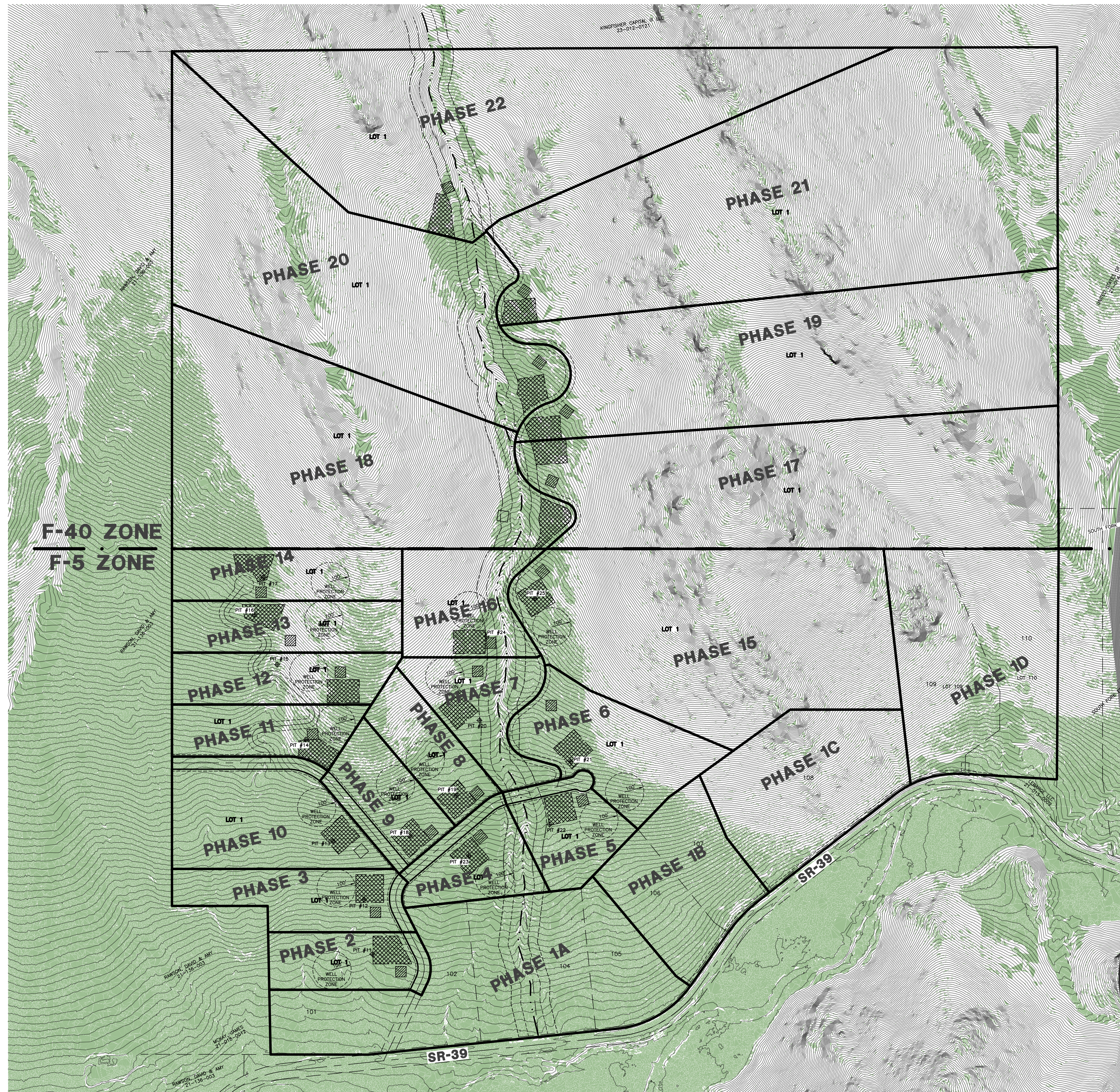

**LEGEND**

- = BOUNDARY LINE/PHASE LINE
- = LOT LINE
- = ADJOINING PROPERTY
- = SECTION TIE LINE
- = PUBLIC UTILITY EASEMENT
- = SEASONAL DRAINAGE STREAM
- = 50' SEASONAL DRAINAGE NO BUILD ZONE
- = 100' SEASONAL DRAINAGE NO BUILD ZONE
- = 20,000 S.F. SEPTIC FIELD
- = MIN. 3,000 S.F. BUILDABLE AREA
- = 100' WELL PROTECTION ZONE

SLOPES TABLE			
NUMBER	MINIMUM SLOPE	MAXIMUM SLOPE	COLOR
1	0.00%	25.00%	

**F-40 ZONE**  
**F-5 ZONE**

**F-40 ZONE**  
**F-5 ZONE**

# Gateway Estates Subdivision

Weber County, Utah

**Developer:**

Matt Lowe  
6028 S. Ridgeline Dr., Ste. 200  
Ogden, UT. 84405  
(801) 648-8229

**Reeve & Associates, Inc.**

**IRA**

5160 SOUTH 1500 WEST, RIVERDALE, UTAH 84405  
TEL: (801) 621-3100 FAX: (801) 621-2666 www.reeve-associates.com  
LAND PLANNERS • CIVIL ENGINEERS • LAND SURVEYORS  
ARCHITECTS • STRUCTURAL ENGINEERS • LANDSCAPE ARCHITECTS

DATE	DESCRIPTION
4-22-21	LOI REVISIONS
6-17-21	ROAD REVISION
4-26-23	SEPARATE PHASES

**Gateway Estates Subdivision**  
ALL OF SECTION 11, T.6N., R.2E., S.LB & M., U.S. SURVEY  
WEBER COUNTY, UTAH

**Slope Analysis**

**Project Info.**

Engineer:	N. Reeve
Designer:	C. Cave
Begin Date:	4-18-23
Name:	GATEWAY ESTATES SUBDIVISION
Number:	4825-26