

THE RIDGE TOWNHOMES PHASE 1

PART OF THE NORTHEAST 1/4 OF SECTION 27
T7N, R1E, SLB & M, U.S. SURVEY
WEBER COUNTY, UTAH

SEPTEMBER 2014



LINE TABLE		
LINE #	LENGTH	BEARING
L248	15.758	N76° 41' 09"W
L250	7.012	S13° 18' 51"W
L251	14.316	S76° 41' 09"E
L252	53.352	N54° 20' 13"W
L253	15.924	N19° 22' 23"E
L254	14.974	S19° 22' 23"W
L255	15.003	N17° 53' 00"E
L256	31.000	N72° 07' 00"W
L257	15.000	S17° 53' 00"W
L259	8.467	N72° 07' 00"W
L260	1.126	N10° 29' 10"W
L261	29.160	N66° 05' 07"W
L263	3.188	S72° 07' 00"E
L265	52.885	S54° 20' 13"E
L267	9.382	N66° 05' 07"W
L268	28.554	N76° 41' 09"W
L269	4.935	S76° 41' 09"E
L270	16.834	S17° 53' 00"W
L271	20.000	S72° 07' 00"E
L272	6.329	N17° 53' 00"E
L273	11.250	S66° 05' 07"E
L309	0.089	N4° 09' 59"W
L310	0.089	N4° 09' 59"W
L311	1.125	S10° 29' 10"E

CURVE TABLE					
CURVE #	LENGTH	RADIUS	DELTA	CHORD BEARING	CHORD LENGTH
C8	43.03	40.00	61° 37' 51"	S41° 18' 05"E	40.98
C9	4.71	3.00	90° 00' 00"	N62° 53' 00"E	4.24
C10	1.15	160.00	0° 24' 42"	S71° 33' 13"E	1.15
C11	4.69	3.00	89° 38' 33"	S26° 56' 17"E	4.23
C12	4.67	3.00	89° 16' 45"	N64° 00' 46"E	4.22
C13	22.04	178.00	7° 05' 42"	S67° 43' 23"E	22.03
C14	4.23	3.00	80° 50' 22"	S21° 02' 48"E	3.89
C15	19.91	160.00	7° 07' 46"	S57° 54' 06"E	19.90
C16	38.49	32.00	68° 55' 12"	S19° 52' 37"E	36.21
C17	7.21	8.00	51° 39' 29"	S11° 14' 46"E	6.97
C18	15.19	12.00	72° 31' 10"	N40° 25' 34"W	14.19
C19	15.66	28.00	32° 02' 27"	N20° 11' 12"W	15.45
C20	8.64	10.00	49° 31' 17"	N11° 26' 47"W	8.38
C21	34.48	26.00	75° 58' 59"	N69° 53' 30"E	32.01
C22	43.44	140.00	17° 46' 47"	S63° 13' 37"E	43.27
C23	16.46	5.81	162° 17' 51"	N29° 30' 44"E	11.48
C24	20.03	26.00	44° 08' 41"	N29° 06' 08"W	19.54
C25	42.61	60.00	40° 41' 19"	N30° 49' 49"W	41.72

NON-TANGENT
NON-TANGENT

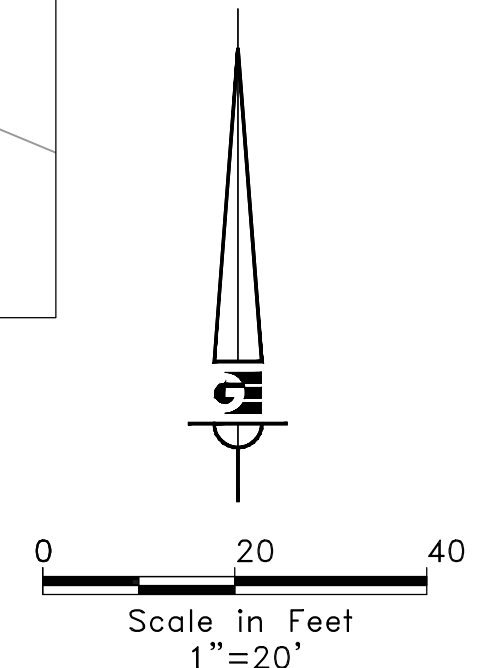

LEGEND

- SECTION LINE
- CENTERLINE
- RIGHT-OF-WAY LINE
- PROPERTY BOUNDARY
- PUBLIC UTILITY EASEMENT (PUE)
- BUILDING TIES
- PRIVATE
- ▨ LIMITED COMMON AREA
- COMMON AREA

SHEET 5 OF 5

Prepared By:

GARDNER ENGINEERING
CIVIL - LAND PLANNING
MUNICIPAL - LAND SURVEYING
5150 SOUTH 375 EAST OGDEN, UT
OFFICE: 801.476.0202 FAX: 801.476.0066
www.gardnereengineering.net

COUNTY RECORDER

ENTRY NO. _____ FEE PAID _____

IN _____ FILED FOR RECORD AND _____ AT _____

RECORDED _____, AT _____

IN _____ BOOK OF OFFICIAL RECORDS, PAGE _____, RECORDED _____

FOR _____

_____ COUNTY RECORDER

BY: _____ DEPUTY