

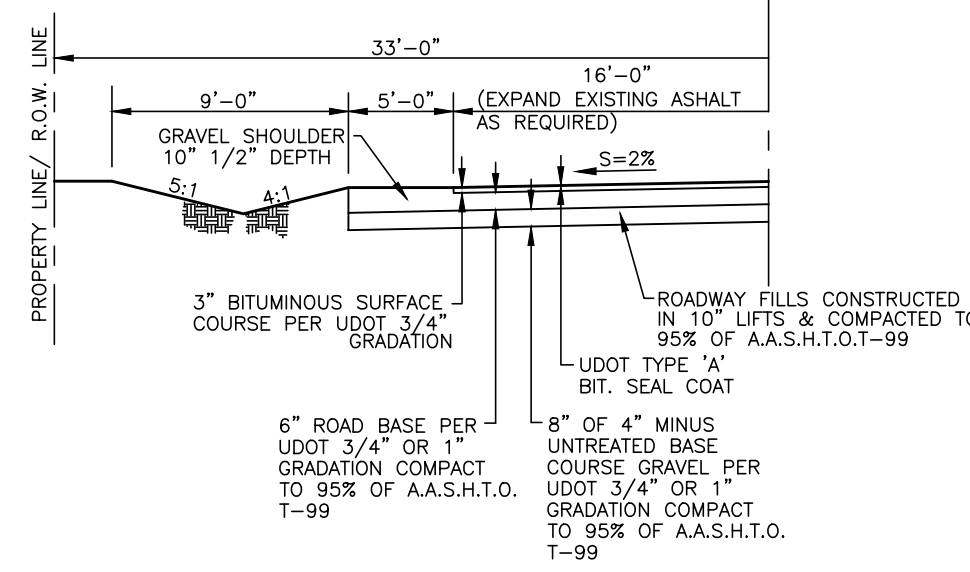

Vicinity Map

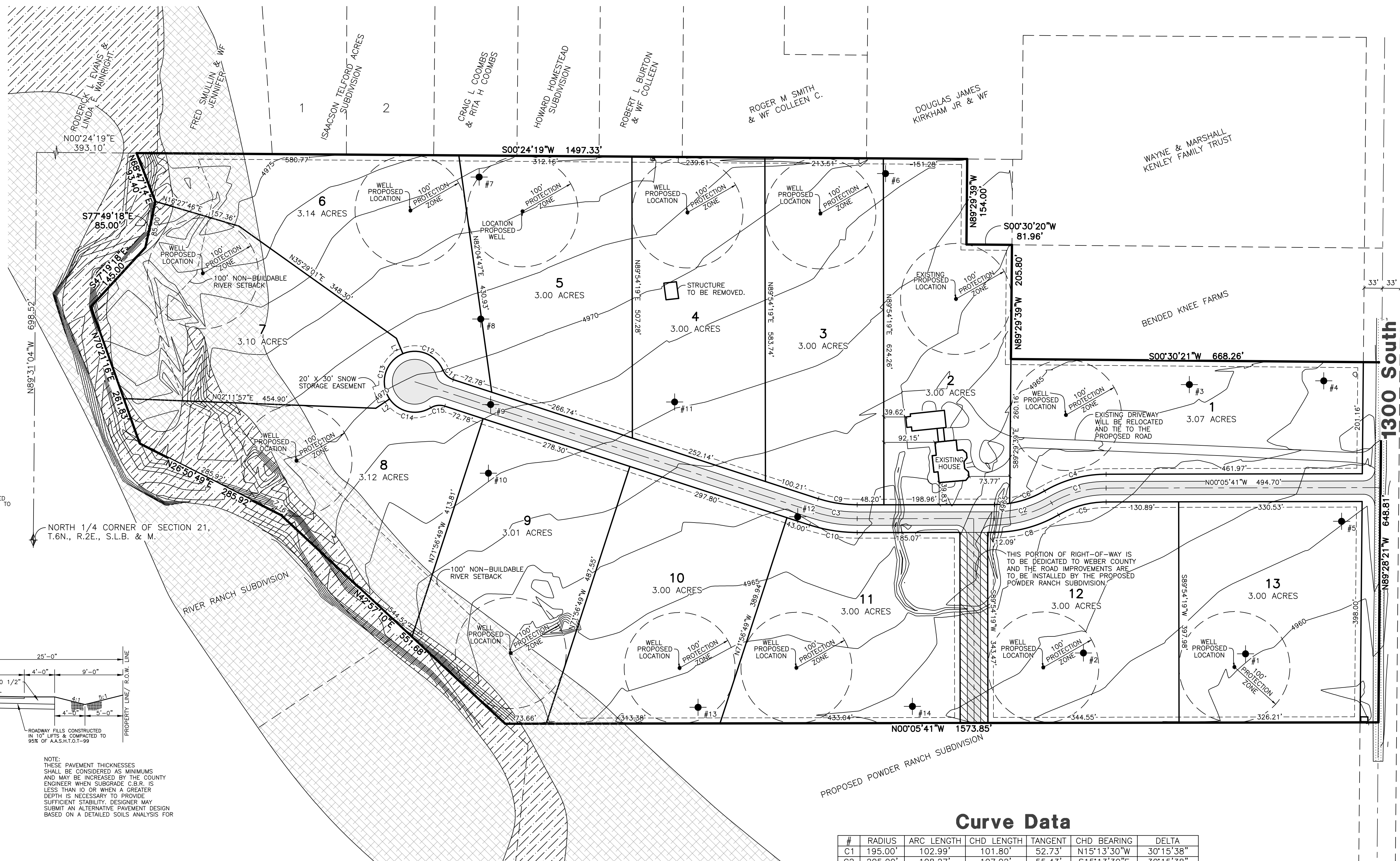

1300 South Street Section

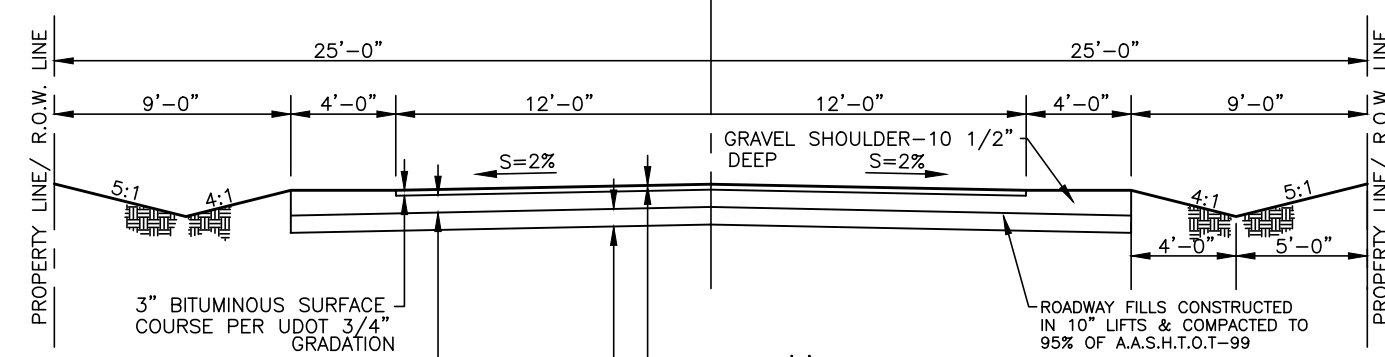

Street Section (50' R.O.W.)

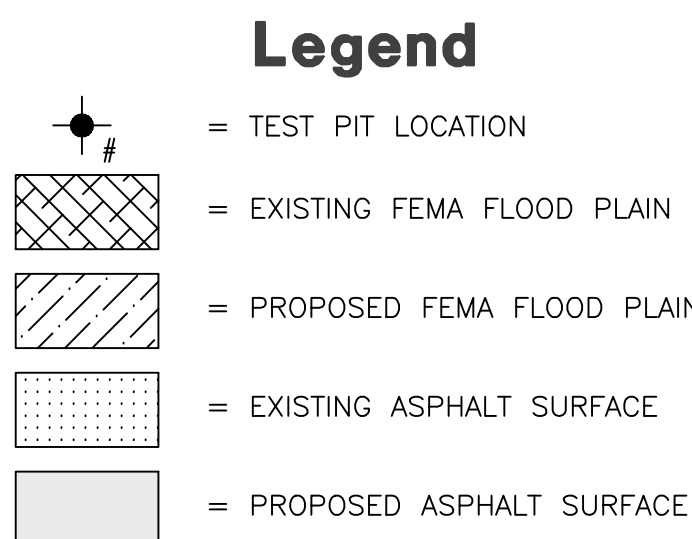

- NOTES:
- CONTOURS ARE SHOWN WITH A ONE FOOT INTERVAL.
  - DUE TO THE FACT THAT THERE IS NO STORM DRAINAGE SYSTEM IN THIS AREA WE ARE PROPOSING THAT CHECK DAMS BE DESIGNED INTO THE ROADSIDE DITCHES.

**Line Data**

LINE	BEARING	DISTANCE
L1	N66°57'31"E	30.00'
L2	S34°09'06"E	30.00'

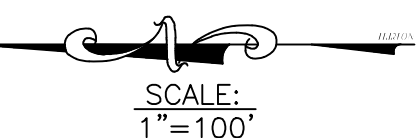

**Curve Data**

#	RADIUS	ARC LENGTH	CHD LENGTH	TANGENT	CHD BEARING	DELTA
C1	195.00'	102.99'	101.80'	52.73'	N15°13'30"W	30°15'38"
C2	205.00'	108.27'	107.02'	55.43'	S15°13'30"E	30°15'38"
C3	250.00'	79.19'	78.86'	39.93'	S08°58'45"W	18°08'53"
C4	220.00'	116.19'	114.85'	59.49'	N15°13'30"W	30°15'38"
C5	170.00'	89.78'	88.74'	45.97'	N15°13'30"W	30°15'38"
C6	180.00'	67.18'	66.79'	33.99'	S19°39'47"E	21°23'05"
C7	180.00'	27.88'	27.86'	13.97'	S04°31'58"E	8°52'33"
C8	230.00'	121.47'	120.07'	62.19'	S15°13'30"E	30°15'38"
C9	225.00'	71.27'	70.97'	35.93'	S08°58'45"W	18°08'53"
C10	275.00'	87.10'	86.74'	43.92'	S08°58'45"W	18°08'53"
C11	30.00'	26.01'	25.21'	13.89'	S42°53'35"W	49°40'47"
C12	55.00'	87.14'	78.31'	55.75'	N22°20'45"E	90°46'28"
C13	55.00'	97.06'	84.95'	66.85'	N73°35'48"W	101°06'37"
C14	55.00'	83.97'	76.05'	52.63'	S12°06'39"W	87°28'30"
C15	30.00'	26.01'	25.21'	13.89'	N06°47'12"W	49°40'47"

**Developer:**  
 Matt Lowe  
 6028 S. Ridgeline Dr., Ste. 100  
 South Ogden, UT. 84405  
 (801) 645-1044



**REVISIONS**

DATE	DESCRIPTION
9-27-13	REVISION LAYOUT FOR SUB
11-27-13	ENGINEERING REVIEW COMMENTS

**Silver Summit Estates**  
 WEBER COUNTY, UTAH  
**Preliminary Plan**



**Project Info.**  
 Engineer: N. Reeve  
 Designer: C. Cave  
 Begin Date: September 18, 2013  
 Name: Silver Summit Estates  
 Number: 4825-08

Sheet	1
1	Sheets