



# Land Use Permit

## Weber County Planning Commission

2380 Washington Blvd. STE 240

Ogden, UT 84401

Phone: (801) 399-8791 FAX: (801) 399-8862

webercountyutah.gov/planning

**Permit Number: LUP69-2023**

Permit Type: Structure

Permit Date: 04/27/2023

### Applicant

**Name:** Brendan Armbruster

**Business:**

**Address:**

, UT

**Phone:** 9498997422

### Owner

**Name:** Brian Foremaster

**Business:**

**Address:** 2397 N 1500 W

Ogden, UT 84401

**Phone:** 801-737-0265

### Parcel

**Parcel:** 190600016

**Zoning:** M-1 **Area:** 2

**Sq Ft:**

**Lot(s):** 13

**Subdivision:** Weber Ind. Park

**Address:** 2397 N RULON WHITE BLVD OGDEN, UT 84404

**T - R - S - QS:** 7N - 2W - 36 -

### Proposal

**Proposed Structure:** Wall sign, Mon. sign

**Building Footprint:** 8

**Proposed Structure Height:** 5

**Max Structure Height in Zone:** 25

**# of Dwelling Units:** 0

**# of Accessory Bldgs:** 1

**# Off Street Parking Reqd:**

**\*Is Structure > 1,000 Sq. Ft?** No

\*If True Need Certif. Statement

### Permit Checklist

**Access Type:** Public Own Front

**Alternative Access File #**

**Greater than 4218 ft above sea level?** Yes

**Wetlands/Flood Zone?** No

**Additional Setback Reqd. ?** No

**Meet Zone Area Frontage?** Yes

**> 200 ft from paved Road?** No

**Hillside Review Reqd?** No

**Culinary Water District:**

**Waste Water System:**

### Comments

This land use permit is issued after the plans for a wall sign and a freestanding sign for the Foremaster Tool Precision Machining business display compliance with applicable land use code, specifically the M-1 Zone code and the Western Weber Sign Code. All signs that are illuminated by electricity shall comply with the adopted electrical code and fire prevention code of the county.

# Land Use Permit

## Structure Setback Graphic: New Dwelling, Addition, Etc.

**\*\*See additional notes in the comments section\*\***

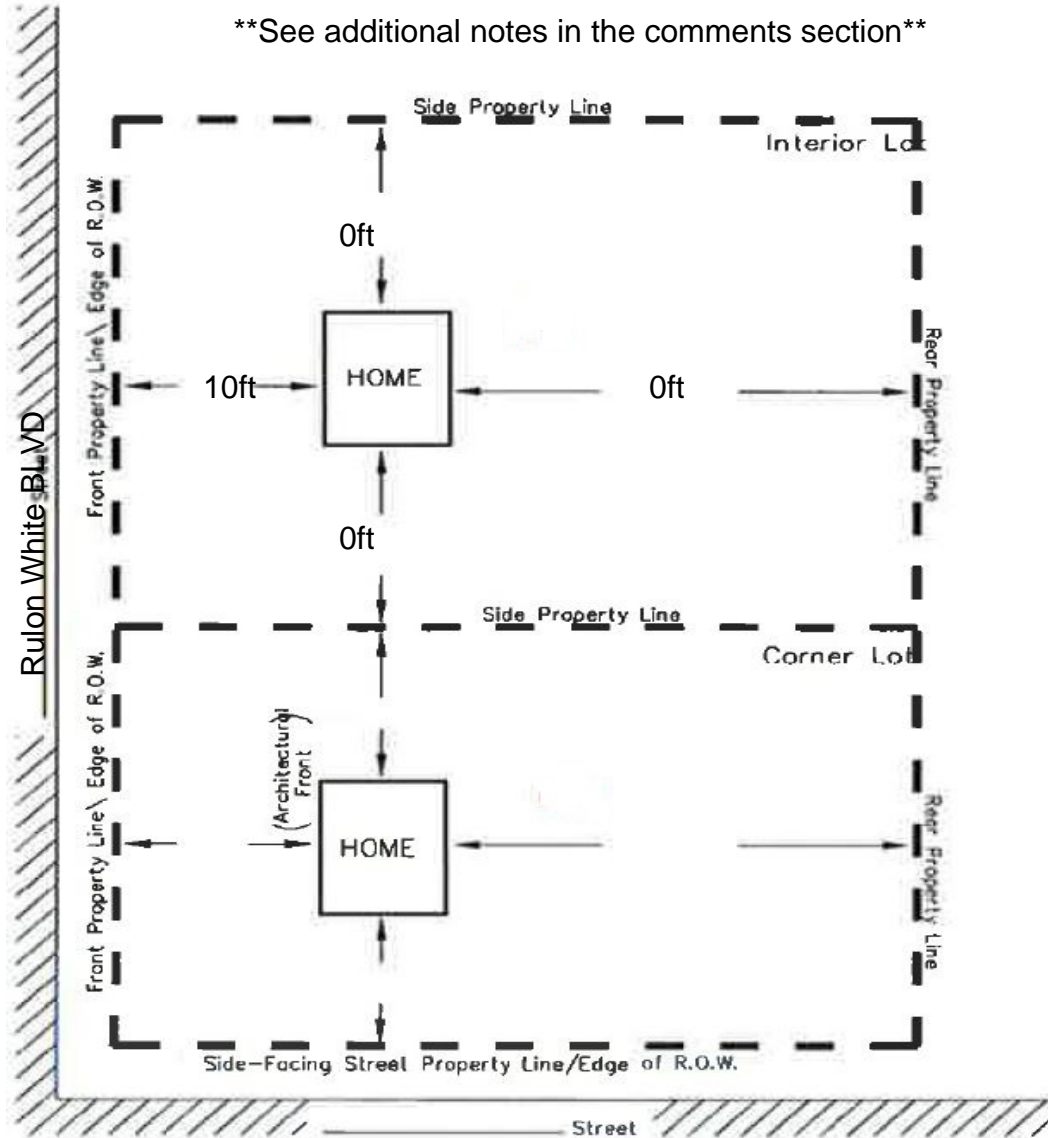

### MINIMUM YARD SETBACKS New Dwelling, Addition, Etc.

**NOTICE FOR APPLICANT (Please Read Before Signing)**

Proposals for the installation of an individual water supply and for a sanitary waste disposal system (septic tank) for any structure designed for human occupation must be approved by Weber County Health Department prior to installation.

Felix Lleverino

04/27/2023

Planning Dept. Signature of Approval

Date

I hereby certify that I have read and examined this application and know the same to be true and correct. All provisions of laws and ordinances governing this land use will be complied with whether specified herein or not. I make this statement under penalty of perjury.

\_\_\_\_\_  
Contractor/Owner Signature of Approval

\_\_\_\_\_  
Date