

# PARKSIDE P.R.U.D PHASE 3 A PLANNED RESIDENTIAL UNITI DEVELOPMENT

LOCATED IN THE SOUTHWEST QUARTER OF SECTION 15,  
TOWNSHIP 7 NORTH, RANGE 1 EAST, SALT LAKE BASE AND MERIDIAN,  
WEBER COUNTY, UTAH  
SEPTEMBER 2022

Permanent street monuments shall be accurately set at points necessary to establish all lines of the street. Centerline monuments shall be noted on the final plat. WCO 106-4-2.7 & WCO 106-1-8.20(a)(13)  
\*When street monuments are required, send "Subdivision Monumentation Letter" to developer of Subdivision to notify of the MIA and its associated costs.

The existing location, widths, and other dimensions of all existing or platted streets and other important features such as, but not limited to, railroad lines... within and immediately adjacent (within 30') to the tract of land to be subdivided. WCO 106-1-5.10(f)

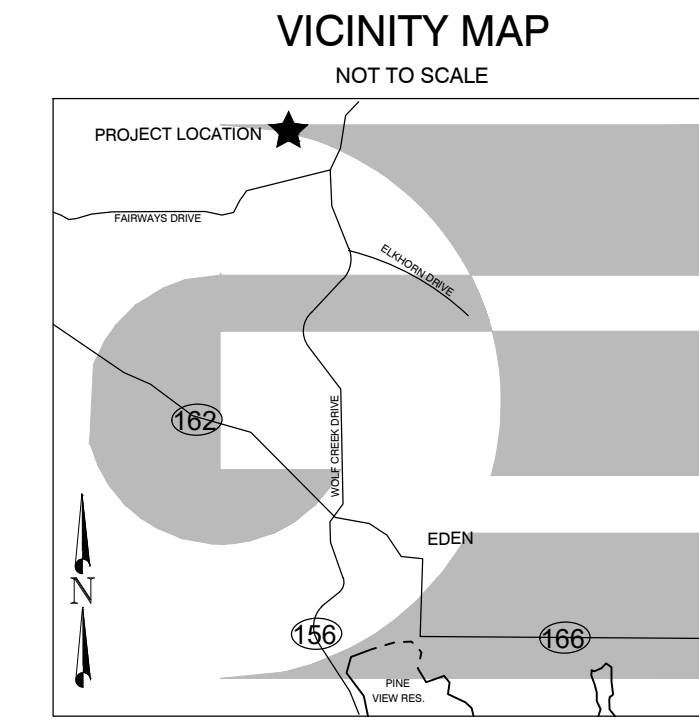

**BOUNDARY DESCRIPTION**  
A PART OF THE SOUTHWEST QUARTER OF SECTION 15, TOWNSHIP 7 NORTH, RANGE 1 EAST, OF THE SALT LAKE BASE AND MERIDIAN MORE PARTICULARLY DESCRIBED AS FOLLOWS:  
BEGINNING AT A POINT ON THE NORTH BOUNDARY LINE OF PARKSIDE P.R.U.D. PHASE 2B BEING LOCATED SOUTH 89°12'43" EAST 939.14 FEET ALONG THE SOUTH LINE OF SAID SOUTHWEST QUARTER AND NORTH 00°00'00" EAST 473.61 FEET FROM THE SOUTH QUARTER CORNER OF SAID SECTION 15, RUNNING THENCE ALONG THE BOUNDARY OF SAID PARKSIDE P.R.U.D. PHASE 2B THE FOLLOWING THREE (3) COURSES: (1) SOUTH 56°24'02" WEST 276.00 FEET; (2) SOUTH 74°44'48" WEST 141.86 FEET; (3) SOUTH 67°12'32" WEST 251.83 FEET; THENCE NORTH 28°53'55" WEST 104.63 FEET; THENCE NORTH 11°03'26" WEST 52.21 FEET; THENCE NORTH 27°14'54" WEST 110.01 FEET; THENCE NORTH 62°00'06" EAST 77.86 FEET; THENCE NORTH 76°28'51" EAST 50.67 FEET; THENCE NORTH 62°00'06" EAST 71.55 FEET; THENCE NORTH 62°00'06" EAST 274.27 FEET; THENCE NORTH 67°07'22" EAST 161.45 FEET TO THE WESTERLY BOUNDARY LINE OF PARKSIDE P.R.U.D. PHASE 1; THENCE ALONG SAID WESTERLY BOUNDARY LINE FOLLOWING THREE (3) COURSES: (1) SOUTH 29°34'23" EAST 108.87 FEET; (2) SOUTH 30°10'47" EAST 50.00 FEET; (3) SOUTH 33°35'58" EAST 106.40 FEET TO THE POINT OF BEGINNING. CONTAINING 182,277 SQUARE FEET OR 4.184 ACRES MORE OR LESS.

**SURVEYOR'S CERTIFICATE**

I, KLINT H. WHITNEY, DO HEREBY CERTIFY THAT I AM A LICENSED PROFESSIONAL LAND SURVEYOR IN THE STATE OF UTAH AND THAT I HOLD CERTIFICATE NO. 8227228 IN ACCORDANCE WITH TITLE 58, CHAPTER 22, OF THE PROFESSIONAL ENGINEERS AND LAND SURVEYORS ACT; I FURTHER CERTIFY THAT BY AUTHORITY OF THE OWNERS I HAVE COMPLETED A SURVEY OF THE PROPERTY AS SHOWN AND DESCRIBED ON THIS PLAT, AND HAVE SUBDIVIDED SAID PROPERTY INTO LOTS AND STREETS, TOGETHER WITH EASEMENTS, HEREAFTER TO BE KNOWN AS PARKSIDE P.R.U.D. PHASE 3 IN ACCORDANCE WITH SECTION 17-23-17 AND HAVE VERIFIED ALL MEASUREMENTS; THAT THE REFERENCE MONUMENTS SHOWN HEREON ARE LOCATED AS INDICATED AND ARE SUFFICIENT TO RETRACE OR REESTABLISH THIS SURVEY; THAT ALL LOTS MEET THE REQUIREMENTS OF THE LAND USE CODE; AND THAT THE INFORMATION SHOWN HEREIN IS SUFFICIENT TO ACCURATELY ESTABLISH THE LATERAL BOUNDARIES OF THE HEREIN DESCRIBED TRACT OF REAL PROPERTY.

SIGNED THIS \_\_\_\_ DAY OF \_\_\_\_\_, 2022.

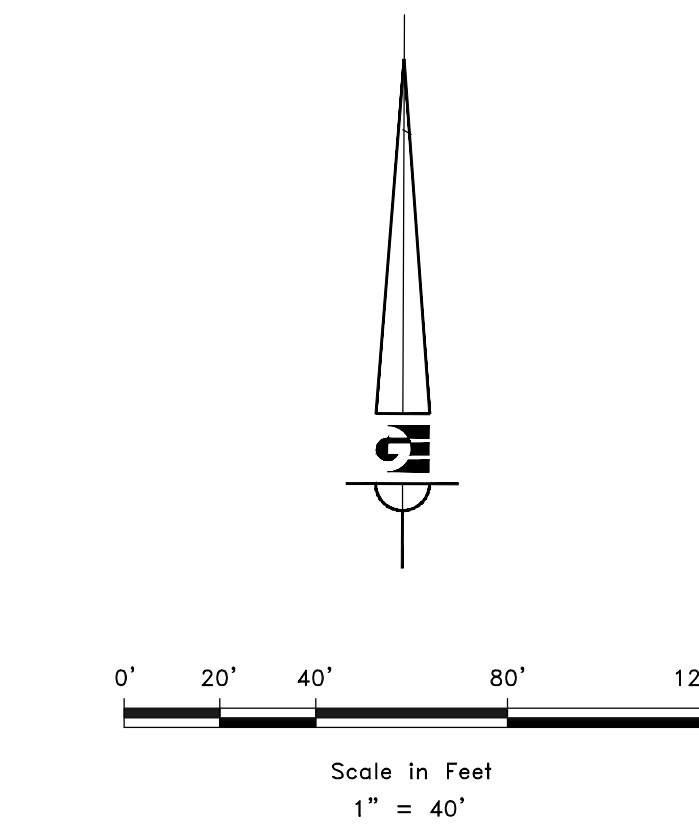
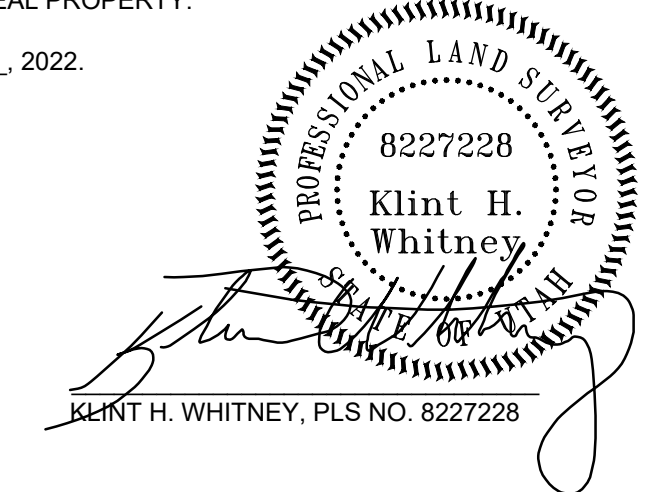

**LEGEND**

- ◆ WEBER COUNTY MONUMENT AS NOTED
- SET 24" REBAR AND CAP MARKED GARDNER ENGINEERING
- FOUND GARDNER REBAR AND CAP
- SUBDIVISION BOUNDARY
- LOT LINE
- - - ADJACENT PARCEL
- - - SECTION LINE
- - - EASEMENT
- x EXISTING FENCE LINE
- ◆ CENTER LINE MONUMENT TO BE INSTALLED

LINE #	LENGTH	BEARING
L1	16.89	S55°22'06"E
L2	20.33	S70°26'16"E
L3	16.01	N62°00'06"E
L4	16.06	N62°00'06"E
L5	16.06	N62°00'06"E
L6	16.01	N62°00'06"E
L7	16.28	N67°07'22"E
L8	16.00	N67°07'22"E
L9	16.28	N0°00'36"E
L10	17.06	S56°43'06"E
L11	21.20	N22°09'57"E
L12	16.01	N67°12'32"E
L13	16.07	N74°44'48"E
L14	16.86	N74°44'48"E
L15	16.00	N56°24'02"E
L16	16.00	N56°24'02"E
L17	16.00	N56°24'02"E
L18	17.04	S61°55'31"E

**OWNER'S DEDICATION**

I THE UNDERSIGNED OWNER OF THE HEREON DESCRIBED TRACT OF LAND, HEREBY SET APART AND SUBDIVIDE THE SAME INTO LOTS, PARCELS AND STREETS AS SHOWN ON THIS PLAT AND NAME SAID TRACT:

**PARKSIDE P.R.U.D. PHASE 3**

AND HEREBY DEDICATE, GRANT AND CONVEY TO WEBER COUNTY, UTAH ALL THOSE PARTS OR PORTIONS OF SAID TRACT OF LAND DESIGNATED AS STREETS, THE SAME TO BE USED AS PUBLIC THOROUGHFARES FOREVER, AND ALSO GRANT AND DEDICATE A PERPETUAL EASEMENT OVER, UPON AND UNDER THE LANDS DESIGNATED ON THE PLAT AS PUBLIC UTILITY, THE SAME TO BE USED FOR THE INSTALLATION, MAINTENANCE AND OPERATION OF PUBLIC UTILITY SERVICE LINES, STORM DRAINAGE FACILITIES OR FOR THE PERPETUAL PRESERVATION OF WATER DRAINAGE CHANNELS IN THEIR NATURAL STATE WHICHEVER IS APPLICABLE AS MAY BE AUTHORIZED BY WEBER COUNTY UTAH, WITH NO BUILDINGS OR STRUCTURES BEING ERECTED WITHIN SUCH EASEMENTS, AND FURTHER GRANT AND CONVEY TO THE SUBDIVISION LOT (UNIT) OWNERS ASSOCIATION, ALL THOSE PARTS OR PORTIONS OF SAID TRACT OF LAND DESIGNATED AS COMMON AREAS TO BE USED FOR RECREATIONAL AND OPEN SPACE PURPOSES FOR THE BENEFIT OF EACH LOT (UNIT) OWNERS ASSOCIATION MEMBER IN COMMON WITH ALL OTHERS IN THE SUBDIVISION AND SUBSEQUENT PHASES OF THE DEVELOPMENT AND GRANT AND DEDICATE TO WEBER COUNTY A PERPETUAL OPEN SPACE RIGHT AND PUBLIC UTILITY EASEMENT ON AND OVER THE COMMON AREAS TO GUARANTEE TO WEBER COUNTY THAT THE COMMON AREAS REMAIN OPEN AND UNDEVELOPED EXCEPT FOR APPROVED RECREATIONAL, PARKING AND OPEN SPACE PURPOSES.

THE BRIDGES HOLDING COMPANY, LLC  
SIGNED THIS \_\_\_\_ DAY OF \_\_\_\_\_, 2022.

BY: JOHN L. LEWIS, MANAGING MEMBER

**ACKNOWLEDGEMENT**

STATE OF UTAH )  
COUNTY OF WEBER )

On this \_\_\_\_ day of \_\_\_\_\_, 2022, personally appeared before me JOHN L. LEWIS, whose identity is personally known to me (or proven on the basis of satisfactory evidence) and who by me duly sworn/affirmed, did say that he/she is the MANAGING MEMBER OF THE BRIDGES HOLDING COMPANY LLC, and that said document was signed by him/her in behalf of said Corporation by Authority of its Bylaws, or (Resolution of its Board of Directors), and said JOHN L. LEWIS acknowledged to me that said Corporation executed the same.

STAMP NOTARY PUBLIC

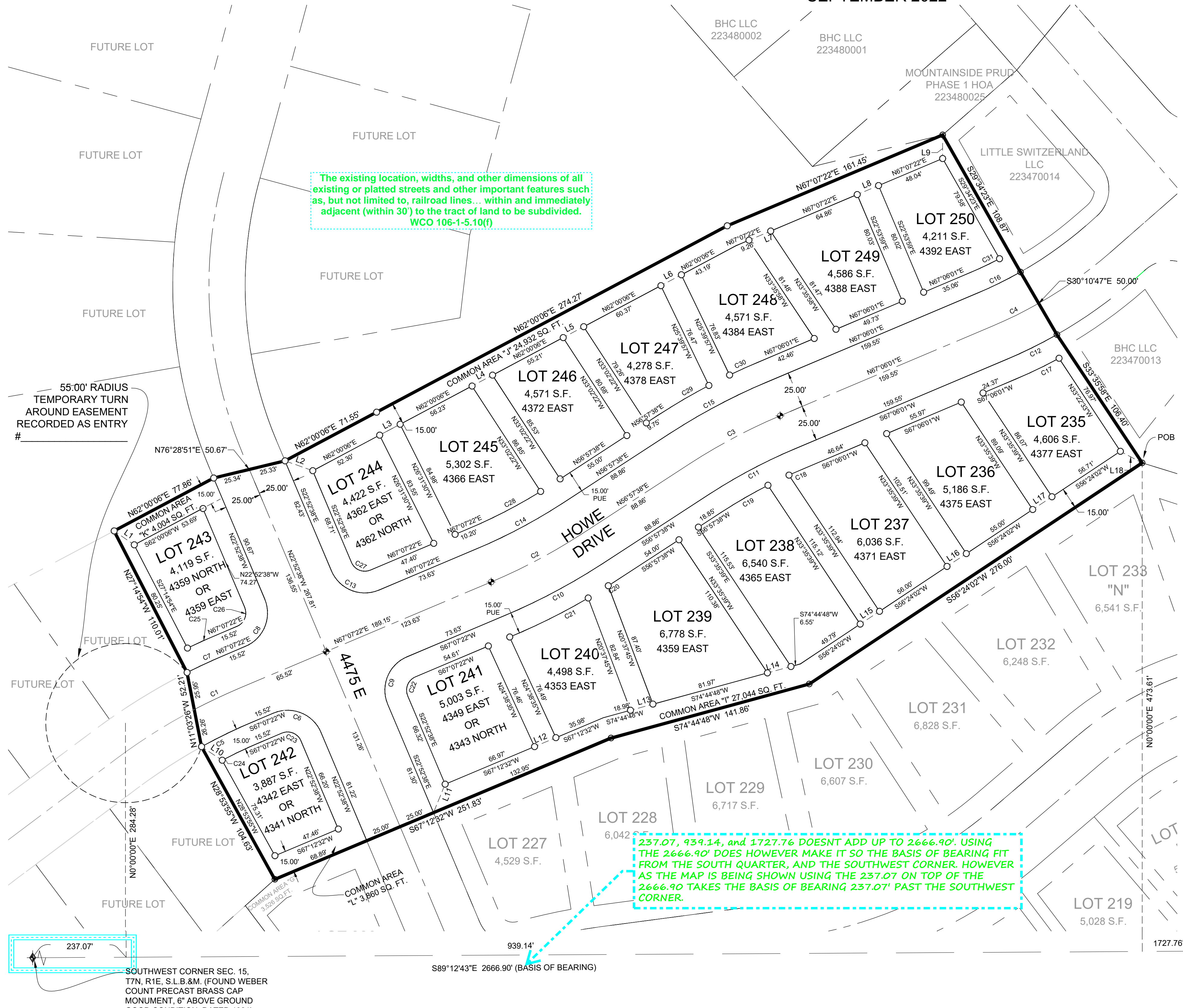

**WEBER COUNTY SURVEYOR**  
I HEREBY CERTIFY THAT THE WEBER COUNTY SURVEYOR'S OFFICE HAS REVIEWED THIS PLAT AND ALL CONDITIONS FOR APPROVAL BY THIS OFFICE HAVE BEEN SATISFIED. THE APPROVAL OF THIS PLAT BY THE WEBER COUNTY SURVEYOR DOES NOT RELIEVE THE LICENSED LAND SURVEYOR WHO EXECUTED THIS PLAT FROM THE RESPONSIBILITIES AND/OR LIABILITIES ASSOCIATED THEREWITH.  
SIGNED THIS \_\_\_\_ DAY OF \_\_\_\_\_, 2022.  
\_\_\_\_\_  
COUNTY SURVEYOR  
RECORD OF SURVEY# \_\_\_\_\_

**WEBER COUNTY ATTORNEY**  
I HAVE EXAMINED THE FINANCIAL GUARANTEE AND OTHER DOCUMENTS ASSOCIATED WITH THIS SUBDIVISION PLAT AND IN MY OPINION THEY CONFORM WITH THE COUNTY ORDINANCE APPLICABLE THERETO AND NOW IN FORCE AND EFFECT.  
SIGNED THIS \_\_\_\_ DAY OF \_\_\_\_\_, 2022.  
\_\_\_\_\_  
COUNTY ATTORNEY

**WEBER COUNTY ENGINEER**  
I HEREBY CERTIFY THAT THE REQUIRED PUBLIC IMPROVEMENT STANDARDS AND DRAWINGS FOR THIS SUBDIVISION CONFORM WITH COUNTY STANDARDS AND THE AMOUNT OF THE FINANCIAL GUARANTEE IS SUFFICIENT FOR THE INSTALLATION OF THESE IMPROVEMENTS.  
SIGNED THIS \_\_\_\_ DAY OF \_\_\_\_\_, 2022.  
\_\_\_\_\_  
COUNTY ENGINEER

**WEBER COUNTY COMMISSION ACCEPTANCE**  
THIS IS TO CERTIFY THAT THIS SUBDIVISION PLAT, THE DEDICATION OF STREETS AND OTHER PUBLIC WAYS AND FINANCIAL GUARANTEE OF PUBLIC IMPROVEMENTS ASSOCIATED WITH THIS SUBDIVISION HEREON ARE HEREBY APPROVED AND ACCEPTED BY THE COMMISSIONERS OF WEBER COUNTY, UTAH.  
SIGNED THIS \_\_\_\_ DAY OF \_\_\_\_\_, 2022.  
\_\_\_\_\_  
CHAIRMAN, WEBER COUNTY COMMISSION  
ATTEST: \_\_\_\_\_  
NAME/TITLE

**WEBER COUNTY PLANNING COMMISSION APPROVAL**  
THIS IS TO CERTIFY THAT THIS SUBDIVISION WAS DULY APPROVED BY THE WEBER COUNTY PLANNING COMMISSION.  
SIGNED THIS \_\_\_\_ DAY OF \_\_\_\_\_, 2022.  
\_\_\_\_\_  
CHAIRMAN, WEBER COUNTY PLANNING COMMISSION

**NARRATIVE**  
THE PURPOSE OF THIS SURVEY WAS TO CREATE A TWELVE (12) LOT SUBDIVISION ON THE PROPERTY AS SHOWN AND DESCRIBED HEREON. THE SURVEY WAS ORDERED BY LEWIS HOMES. THE BASIS OF BEARING IS THE SOUTH LINE OF THE SOUTHWEST QUARTER OF SECTION 15, TOWNSHIP 7 NORTH, RANGE 1 EAST, OF THE SALT LAKE BASE AND MERIDIAN WHICH BEARS SOUTH 89°12'43" EAST WEBER COUNTY, UTAH NORTH, NAD 83 STATE PLANE GRID BEARING. THE RIGHT-OF-WAY OF HOWE DRIVE WAS ESTABLISHED BY HONORING THE EXISTING DEDICATED PLATS CONTAINING AND ADJOINING HOWE DRIVE.

DEVELOPER: BRIDGES OF WOLF CREEK DEVELOPMENT CORP. 3718 NORTH WOLF CREEK DRIVE EDEN, UT 84310 801-430-1507	<b>S1</b> <b>2</b>	COUNTY RECORDER ENTRY NO. _____ FEE PAID _____ FILED FOR AND RECORDED _____ AT _____ IN BOOK _____ OF OFFICIAL _____ RECORDS, PAGE _____ RECORDED _____ FOR _____ COUNTY RECORDER BY: _____
<b>GARDNER ENGINEERING</b> CIVIL • LAND PLANNING MUNICIPAL • LAND SURVEYING 5150 SOUTH 275 EAST EDEN, UT OFFICE: 801-476-0202 FAX: 801-476-0066		

R:\1201 - LEWIS HOMES\THE BRIDGES - PHASE 3 - PARKSIDE SURVEY\EDEN\PHASE3\PLAT.DWG

**PARKSIDE P.R.U.D. PHASE 3**  
 A PLANNED RESIDENTIAL UNIT DEVELOPMENT LOCATED IN THE SOUTHWEST QUARTER  
 OF SECTION 15, TOWNSHIP 7 NORTH, RANGE 1 EAST, SALT LAKE BASE AND MERIDIAN,  
 WEBER COUNTY, UTAH  
 SEPTEMBER 2022

**NOTES**

1. SUBJECT PROPERTY FALLS WITHIN FEMA FLOOD ZONE "X" - AREAS DETERMINED TO BE OUTSIDE THE 0.2% ANNUAL CHANCE FLOODPLAIN. PER FEMA MAP NO. 49057C0229F WITH AN EFFECTIVE DATE OF DECEMBER 16, 2005.
2. "N" DESIGNATION DESIGNATES THAT RESTRICTED LOTS MAY HAVE TO COMPLETE ADDITIONAL GEOLOGIC AND/OR GEOTECHNICAL INVESTIGATION PRIOR TO APPLYING FOR A BUILDING PERMIT WITH WEBER COUNTY.
3. REBAR AND CAP TO BE SET AT REAR LOT CORNERS. CURB NAIL TO BE SET IN CURB AT FRONT LOT LINE EXTENSION.
4. ALL AREAS NOT WITHIN THE BOUNDARIES OF THE FOURTEEN (16) NUMBERED LOTS ARE COMMON AREAS AND FACILITIES, CERTAIN OF WHICH AREAS ARE MARKED AS "CA" HEREON PROVIDED, HOWEVER, APPURTENANT TO THE LOTS ARE PERPETUAL EASEMENTS FOR THE ENCRoACHMENT OF EAVES OF THE BUILDINGS. THE DRIVEWAYS ARE RESERVED FOR THE USE OF THE LOT TO WHICH IT IS APPURTENANT.
5. NIGHTLY RENTALS ARE ALLOWED.
6. PARKSIDE P.R.U.D. PHASE 1 IS LOCATED WITHIN A NATURAL HAZARDS AREA. A GEOTECHNICAL INVESTIGATION HAS BEEN PERFORMED BY GSH ENGINEERING JOB NUMBER 1681-08N-16 DATED JULY 25, 2016. LOTS IDENTIFIED WITH AN "N" WILL REQUIRE FURTHER GEOLOGIC AND GEOTECHNICAL INVESTIGATIONS PRIOR TO SUBMITTING AN APPLICATION FOR A LAND USE AND BUILDING PERMIT. THE FINAL REPORT IS AVAILABLE FOR PUBLIC REVIEW AT THE WEBER COUNTY PLANNING DIVISION OFFICE.
7. THE APPROVED MINIMUM SINGLE FAMILY BUILDING SETBACKS ARE:  
 FRONT - 15.00' FROM RIGHT-OF-WAY LINE  
 REAR - 15.00' FROM SUBDIVISION BOUNDARY LINE  
 INTERIOR SIDE NO CLOSER THE 15.00 FEET TO ADJACENT LOT  
 SIDE FACING STREET ON CORNER LOT - 15.00 FEET FROM RIGHT-OF-WAY LINE  
 SIDE-7.5 FEET FROM SUBDIVISION BOUNDARY LINE

CURVE TABLE					
CURVE #	LENGTH	RADIUS	DELTA	CHORD BEARING	CHORD LENGTH
C1	33.75	400.00	4.83	N64° 42' 21"E	33.74
C2	70.95	400.00	10.16	N62° 02' 30"E	70.85
C3	70.79	400.00	10.14	N62° 01' 49"E	70.70
C4	35.20	300.00	6.72	N63° 44' 22"E	35.18
C5	39.41	375.00	6.02	S64° 06' 43"W	39.39
C6	39.27	25.00	90.00	N67° 52' 38"W	35.36
C7	28.67	425.00	3.86	N65° 11' 26"E	28.66
C8	39.27	25.00	90.00	N22° 07' 22"E	35.36
C9	39.27	25.00	90.00	S22° 07' 22"W	35.36
C10	75.38	425.00	10.16	S62° 02' 30"W	75.28
C11	66.37	375.00	10.14	S62° 01' 49"W	66.28
C12	38.38	325.00	6.77	S63° 43' 01"W	38.36
C13	39.27	25.00	90.00	S67° 52' 38"E	35.36
C14	66.51	375.00	10.16	N62° 02' 30"E	66.42
C15	75.21	425.00	10.14	N62° 01' 49"E	75.12
C16	32.03	279.90	6.56	N63° 44' 31"E	32.01
C17	33.38	340.00	5.62	S64° 17' 17"W	33.36
C18	10.33	360.00	1.64	S66° 16' 43"W	10.33
C19	37.24	360.00	5.93	S59° 55' 25"W	37.22
C20	4.20	440.00	0.55	S57° 14' 02"W	4.20
C21	60.56	440.00	7.89	S63° 34' 18"W	60.51
C22	15.71	10.00	90.00	S22° 07' 22"W	14.14
C23	15.71	10.00	90.00	N67° 52' 38"W	14.14
C24	29.87	360.00	4.75	S64° 44' 44"W	29.86
C25	21.85	440.00	2.84	N65° 42' 01"E	21.84
C26	15.71	10.00	90.00	N22° 07' 22"E	14.14
C27	15.71	10.00	90.00	S67° 52' 38"E	14.14
C28	55.95	360.00	8.91	N62° 40' 12"E	55.90
C29	40.62	440.00	5.29	N59° 36' 19"E	40.61
C30	21.24	440.00	2.77	N65° 43' 02"E	21.24
C31	22.25	264.90	4.81	N64° 36' 41"E	22.25

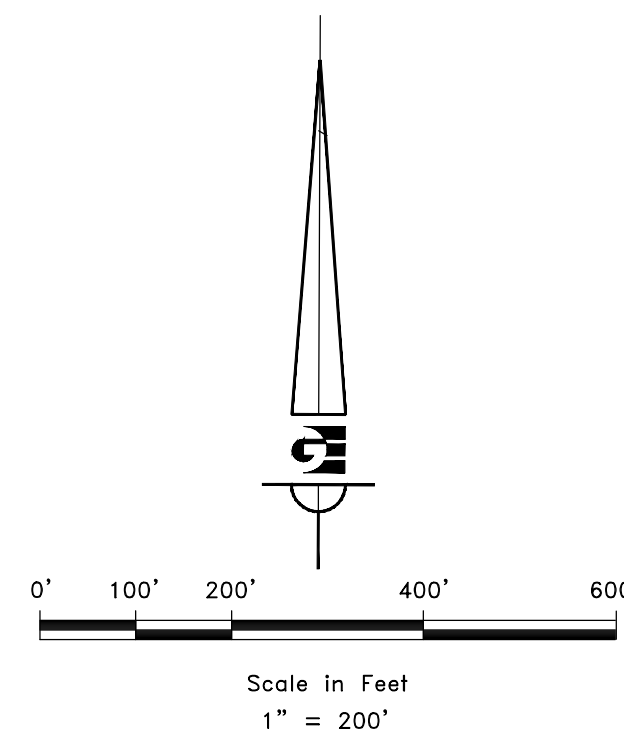

- LEGEND**
- ◆ WEBER COUNTY MONUMENT AS NOTED
  - SET 24" REBAR AND CAP MARKED GARDNER ENGINEERING
  - SUBDIVISION BOUNDARY
  - LOT LINE
  - - - ADJACENT PARCEL
  - - - SECTION LINE
  - - - EASEMENT
  - x EXISTING FENCE LINE

16  
21

16 15  
21 22

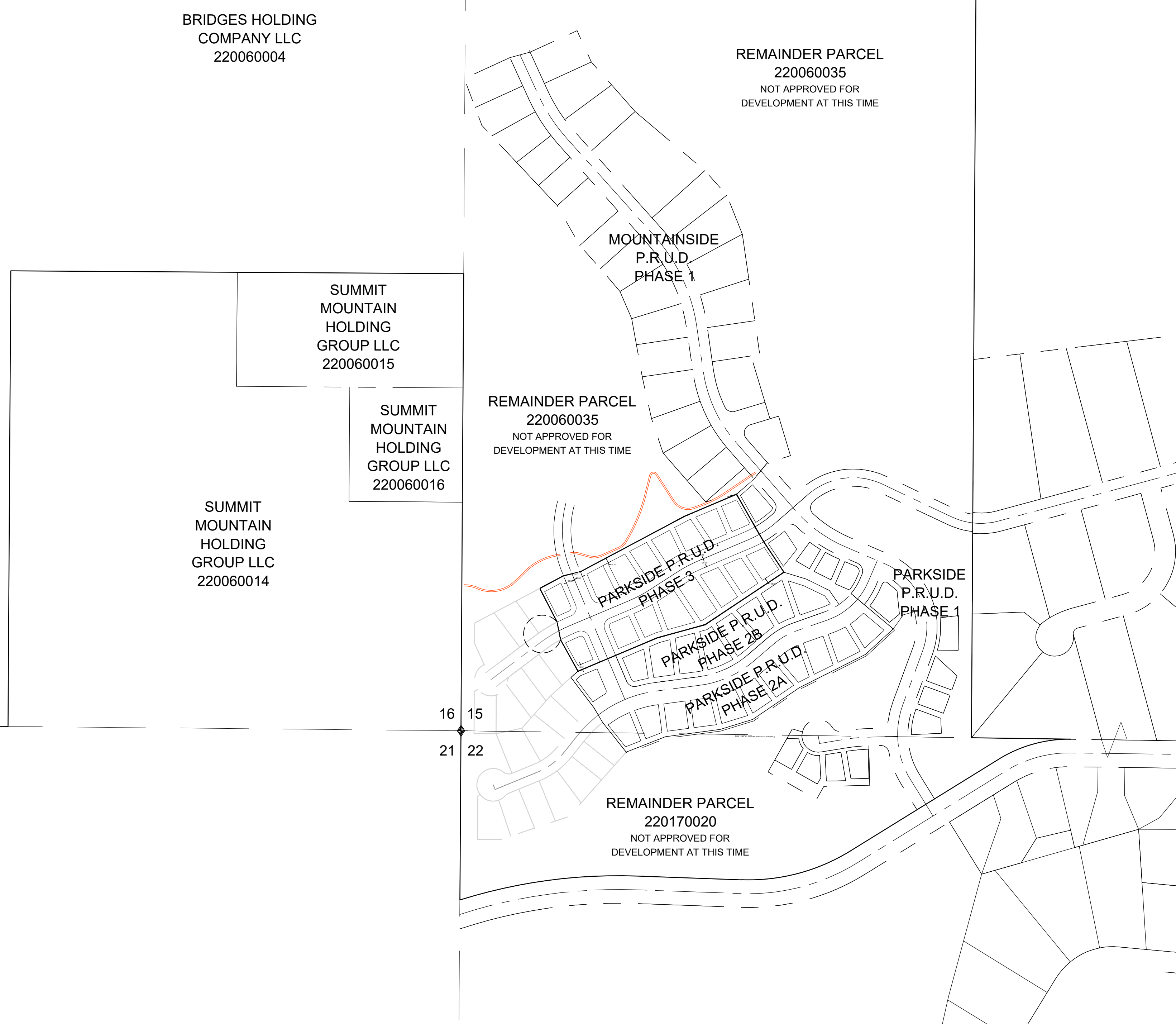

R:\1201 - LEWIS HOMES\THE BRIDGES\PHASE 3 - PARKSIDE\SURVEY\DWG\PHASE3\PLAT.DWG

DEVELOPER: BRIDGES OF WOLF CREEK DEVELOPMENT CORP. 3718 NORTH WOLF CREEK DRIVE EDEN, UT 84310 801-430-1507	<b>S2</b> <hr/> <b>2</b>	COUNTY RECORDER ENTRY NO. _____ FEE PAID _____ FILED FOR AND RECORDED _____ AT _____ IN BOOK _____ OF OFFICIAL _____ RECORDS, PAGE _____ RECORDED _____ FOR _____ COUNTY RECORDER _____ BY: _____
		CIVIL • LAND PLANNING MUNICIPAL • LAND SURVEYING 5150 SOUTH 375 EAST OGDEN, UT OFFICE: 801-476-0202 FAX: 801-476-0666