



Land Use Permit

Weber County Planning Commission

2380 Washington Blvd. STE 240
Ogden, UT 84401
Phone: (801) 399-8791 FAX: (801) 399-8862
webercountyutah.gov/planning

Permit Number: LUP235-2022

Permit Type: Structure
Permit Date: 07/06/2022

Applicant

Name: Scott Nilson
Business:
Address: 3071 N HWY 162
Eden, UT 84310
Phone: 801-393-4512

Owner

Name: Same as applicant
Business:
Address: , UT
Phone:

Parcel

Parcel: 221330003
Zoning: AV-3 **Area:** 16.1 **Sq Ft:** **Lot(s):** 3 **Subdivision:** Eden Estates Subdivision
Address: 3071 N HWY 162 EDEN, UT 84310 **T - R - S - QS:** 7N - 1E - 28 - se

Proposal

Proposed Structure: Shelter for Cows and Ha **Building Footprint:** 864
Proposed Structure Height: 13 **Max Structure Height in Zone:** 25
of Dwelling Units: **# of Accessory Bldgs:**
Off Street Parking Reqd: ***Is Structure > 1,000 Sq. Ft?** No
***If True Need Certif. Statement**

Permit Checklist

Access Type: Mutual Access Easement **Alternative Access File #**
Greater than 4218 ft above sea level? Yes **Wetlands/Flood Zone?** No
Additional Setback Reqd. ? No **Meet Zone Area Frontage?** Yes
> 200 ft from paved Road? N/A **Hillside Review Reqd?** N/A
Culinary Water District: **Waste Water System:**

Comments

there is a 15 ft Utility easement that runs along the north, west and southern lot lines. Foundation and eaves must be placed outside of that easement. per 15A-1-202(1) "Agricultural Use" means a use that relates to tilling of soil and raising of crops, or keeping or raising domestic animals. The structure must be used for agricultural use. Any exterior lighting must comply with Weber County Land Use Code 108-16 (https://weber.municipalcodeonline.com/book?type=ordinances#name=Chapter_108-16_Outdoor_Lighting).

Land Use Permit

Structure Setback Graphic: Barn, Corral, or Stable

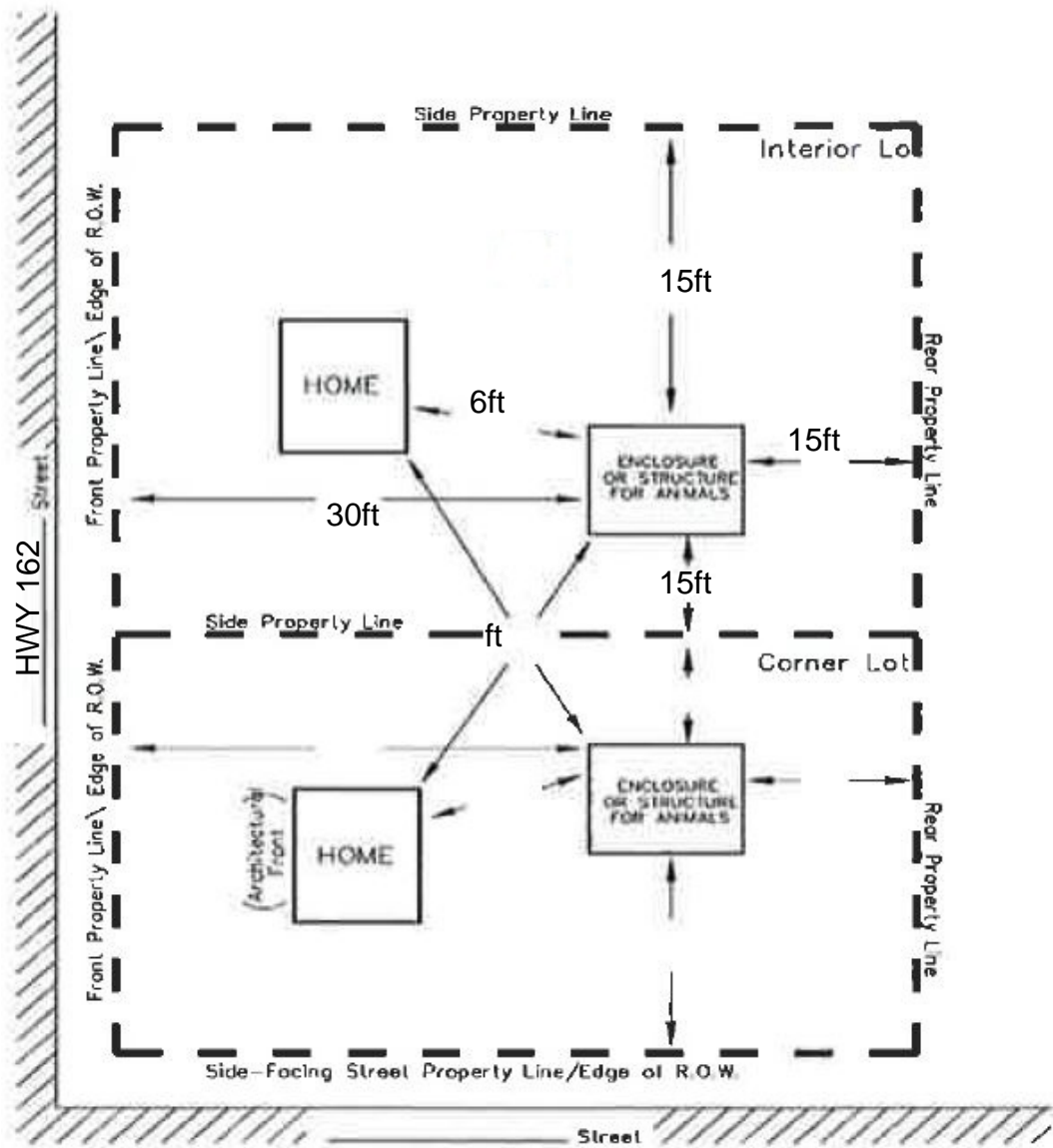

MINIMUM YARD SETBACKS Barn, Corral, or Stable

NOTICE FOR APPLICANT (Please Read Before Signing)

Proposals for the installation of an individual water supply and for a sanitary waste disposal system (septic tank) for any structure designed for human occupation must be approved by Weber County Health Department prior to installation.

Marta Borchert

07/06/2022

Planning Dept. Signature of Approval

Date

I hereby certify that I have read and examined this application and know the same to be true and correct. All provisions of laws and ordinances governing this land use will be complied with whether specified herein or not. I make this statement under penalty of perjury.

Contractor/Owner Signature of Approval

Date