



Land Use Permit

Weber County Planning Commission

2380 Washington Blvd. STE 240

Ogden, UT 84401

Phone: (801) 399-8791 FAX: (801) 399-8862

webercountyutah.gov/planning

Permit Number: LUP223-2022

Permit Type: Structure

Permit Date: 06/30/2022

Applicant

Name: Lance Bingham
Business:
Address: 1141 S 4100 W
Ogden, UT 84404
Phone: 801-528-2337

Owner

Name: Same as applicant
Business:
Address: , UT
Phone:

Parcel

Parcel: 156470001

Zoning: A-1 **Area:** .92 **Sq Ft:**
Address: 1141 S 4100 W OGDEN, UT 84404

Lot(s): **Subdivision:**
T - R - S - QS: 6N - 2W - 21 -

Proposal

Proposed Structure: Ag Ex. Hay Barn

Proposed Structure Height: 35

of Dwelling Units:

Off Street Parking Reqd: 0

Building Footprint: 2400

Max Structure Height in Zone: 35

of Accessory Bldgs: 0

***Is Structure > 1,000 Sq. Ft?** N/A

*If True Need Certif. Statement

Permit Checklist

Access Type: Across front lot line

Greater than 4218 ft above sea level? N/A

Additional Setback Reqd. ? N/A

> 200 ft from paved Road? N/A

Culinary Water District: NA

Alternative Access File #

Wetlands/Flood Zone? N/A

Meet Zone Area Frontage? N/A

Hillside Review Reqd? N/A

Waste Water System: NA

Comments

Proposal is for hay storage and ag use only. No animals proposed to live in this structure. Permit valid once fire and building inspections approve.

Land Use Permit

Structure Setback Graphic: Barn, Corral, or Stable

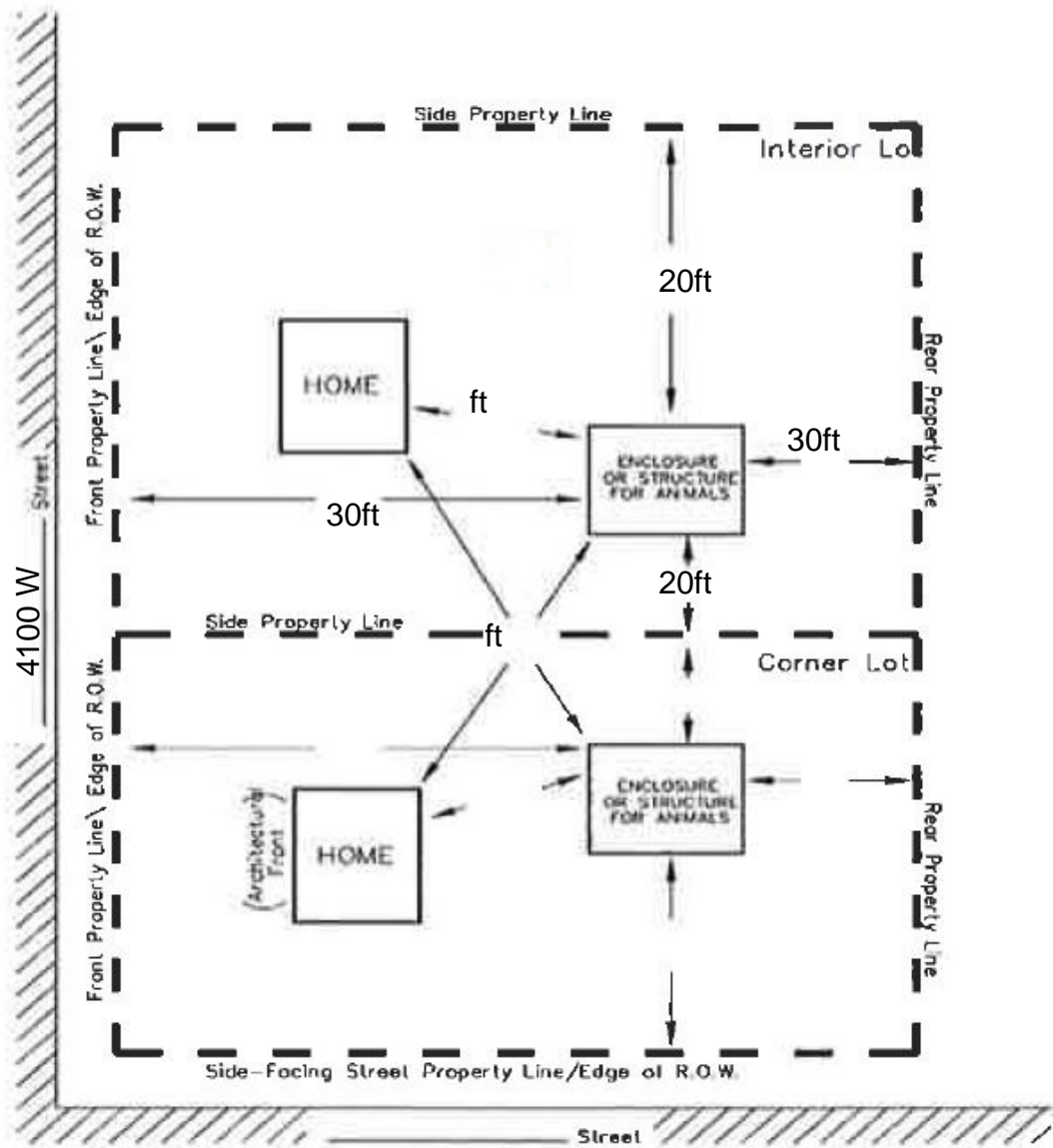

MINIMUM YARD SETBACKS Barn, Corral, or Stable

NOTICE FOR APPLICANT (Please Read Before Signing)

Proposals for the installation of an individual water supply and for a sanitary waste disposal system (septic tank) for any structure designed for human occupation must be approved by Weber County Health Department prior to installation.

Steven Burton

06/30/2022

Planning Dept. Signature of Approval

Date

I hereby certify that I have read and examined this application and know the same to be true and correct. All provisions of laws and ordinances governing this land use will be complied with whether specified herein or not. I make this statement under penalty of perjury.

Contractor/Owner Signature of Approval

Date