

OSPREY RANCH SUBDIVISION PHASE 1

LOCATED IN THE SOUTHEAST QUARTER OF SECTION 33 TOWNSHIP 7 NORTH RANGE 1 EAST AND THE NORTH HALF OF SECTIONS 3, AND 4 OF TOWNSHIP 6 NORTH, RANGE 1 WEST, SALT LAKE BASE AND MERIDIAN, WEBER COUNTY, UTAH, MAY 2022

PHASE 1 BOUNDARY DESCRIPTION

A PART OF THE SOUTHEAST QUARTER OF SECTION 33, TOWNSHIP 7 NORTH, RANGE 1 EAST AND A PART OF THE NORTH HALF OF SECTIONS 3 AND 4 OF TOWNSHIP 6 NORTH, RANGE 1 EAST, OF THE SALT LAKE BASE AND MERIDIAN, BEGINNING AT A POINT ON THE EAST LINE OF SAID SOUTHEAST QUARTER BEING LOCATED NORTH 00°22'52" EAST 1323.89 FEET ALONG THE EAST LINE OF SAID SECTION 33 FROM THE SOUTHEAST CORNER OF SAID SECTION 33; RUNNING THENCE ALONG SAID EAST LINE SOUTH 00°22'52" WEST 672.71 FEET; THENCE NORTH 70°00'53" WEST 107.12 FEET; THENCE SOUTH 10°11'47" WEST 178.55 FEET; THENCE SOUTH 05°08'51" EAST 152.07 FEET; THENCE SOUTH 00°17'39" WEST 360.00 FEET; THENCE SOUTH 89°19'35" EAST 1690.75 FEET TO THE WEST RIGHT-OF-WAY LINE OF STATE HIGHWAY 158; THENCE ALONG SAID WEST RIGHT-OF-WAY LINE THE FOLLOWING FOUR (4) COURSES: (1) SOUTH 26°32'40" EAST 650.08 FEET; (2) SOUTH 36°16'03" EAST 1586.42 FEET; (3) ALONG THE ARC OF A 1530.00 FOOT RADIUS CURVE TO THE RIGHT 383.09 FEET, HAVING A CENTRAL ANGLE OF 14°20'46", CHORD BEARS SOUTH 26°16'20" EAST 382.09 FEET; (4) SOUTH 19°05'57" EAST 476.77 FEET; THENCE NORTH 90°00'00" WEST 4460.96 FEET; THENCE NORTH 00°19'53" EAST 1349.11 FEET; THENCE NORTH 45°00'00" EAST 160.42 FEET; THENCE NORTH 00°00'00" EAST 161.54 FEET; THENCE NORTH 53°49'45" EAST 43.58 FEET; THENCE ALONG THE ARC OF A 159.34 FOOT RADIUS CURVE TO THE RIGHT 47.46 FEET, HAVING A CENTRAL ANGLE OF 17°04'00", CHORD BEARS NORTH 19°43'35" WEST 47.29 FEET; THENCE NORTH 14°27'09" WEST 122.80 FEET; THENCE ALONG THE ARC OF A 122.92 FOOT RADIUS CURVE TO THE LEFT 126.51 FEET, HAVING A CENTRAL ANGLE OF 58°57'54", CHORD BEARS NORTH 43°34'35" WEST 121.00 FEET; THENCE ALONG THE ARC OF A 328.00 FOOT RADIUS CURVE TO THE LEFT 16.92 FEET, HAVING A CENTRAL ANGLE OF 02°57'23", CHORD BEARS NORTH 71°10'07" WEST 16.92 FEET; THENCE NORTH 00°15'55" EAST 780.64 FEET; THENCE ALONG THE ARC OF A 120.68 FOOT RADIUS CURVE TO THE LEFT 63.53 FEET, HAVING A CENTRAL ANGLE OF 30°09'48", CHORD BEARS NORTH 78°44'38" WEST 62.80 FEET; THENCE ALONG THE ARC OF A 167.15 FOOT RADIUS CURVE TO THE RIGHT 101.44 FEET, HAVING A CENTRAL ANGLE OF 34°46'15", CHORD BEARS NORTH 73°52'07" WEST 99.89 FEET; THENCE NORTH 89°30'41" WEST 483.94 FEET; THENCE NORTH 00°11'58" EAST 1283.62 FEET; THENCE SOUTH 89°28'52" EAST 1965.83 FEET TO THE POINT OF BEGINNING, CONTAINING 283.839 ACRES.

AREA CALCULATIONS

TOTAL PROJECT AREA - 595.94 ACRES
 PHASE 1 AREA - 283.782 ACRES
 TOTAL COMMON AREA - 38.66 ACRES
 PHASE 1 COMMON AREA - 28.54 ACRES
 COMMUNITY PARK AREA - 2.05 ACRES

SURVEYOR'S CERTIFICATE

I, KLINT H. WHITNEY, DO HEREBY CERTIFY THAT I AM A LICENSED PROFESSIONAL LAND SURVEYOR IN THE STATE OF UTAH AND THAT I HOLD CERTIFICATE NO. 8227228 IN ACCORDANCE WITH TITLE 58, CHAPTER 22, OF THE PROFESSIONAL ENGINEERS AND LAND SURVEYORS ACT. I FURTHER CERTIFY THAT BY AUTHORITY OF THE OWNERS I HAVE COMPLETED A SURVEY OF THE PROPERTY AS SHOWN AND DESCRIBED ON THIS PLAT AND HAVE SUBDIVIDED SAID PROPERTY INTO LOTS AND STREETS, TOGETHER WITH EASEMENTS, HEREAFTER TO BE KNOWN AS OSPREY RANCH PHASE 1 IN ACCORDANCE WITH SECTION 17-23-17 AND HAVE VERIFIED ALL MEASUREMENTS; THAT THE REFERENCE MONUMENTS SHOWN HEREON ARE LOCATED AS INDICATED AND ARE SUFFICIENT TO RETRACE OR REESTABLISH THIS SURVEY; THAT ALL LOTS MEET THE REQUIREMENTS OF THE LAND USE CODE; AND THAT THE INFORMATION SHOWN HEREIN IS SUFFICIENT TO ACCURATELY ESTABLISH THE LATERAL BOUNDARIES OF THE HEREIN DESCRIBED TRACT OF REAL PROPERTY.

SIGNED THIS _____ DAY OF _____, 2022.

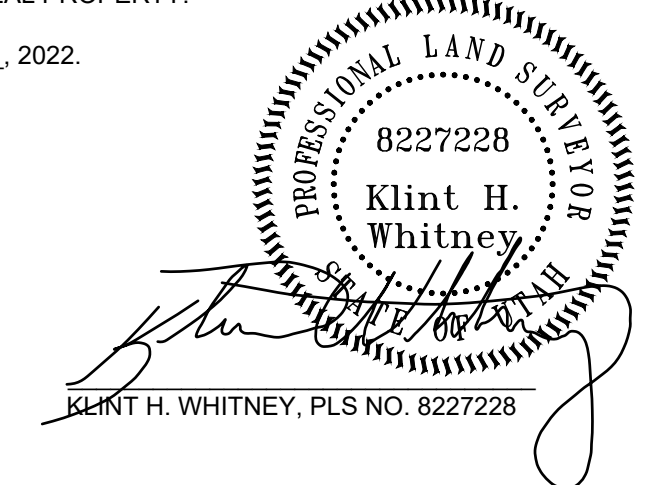

OWNER'S DEDICATION

I THE UNDERSIGNED OWNER OF THE HEREON DESCRIBED TRACT OF LAND, HEREBY SET APART AND SUBDIVIDE THE SAME INTO LOTS, PARCELS AND STREETS AS SHOWN ON THIS PLAT AND NAME SAID TRACT:

OSPREY RANCH PHASE 1

AND DOES HEREBY GRANT AND CONVEY TO THE OSPREY RANCH OWNERS ASSOCIATION, INC. (AND ITS SUCCESSORS AND ASSIGNS) WHOSE MEMBERSHIP CONSISTS OF THE MEMBERS/OWNERS OF SAID ASSOCIATION, THEIR GRANTEEES, SUCCESSORS AND/OR ASSIGNS, A RIGHT OF WAY TO BE USED IN COMMON WITH ALL OTHERS WITHIN SAID SUBDIVISION ON, OVER AND ACROSS ALL THOSE PORTIONS OR PARTS OF SAID TRACT OF LAND DESIGNATED AND DEPICTED ON SAID PLAT AS PRIVATE STREET (PRIVATE RIGHTS-OF-WAY) FOR ACCESS TO THE INDIVIDUAL LOTS, WITH SUCH PRIVATE STREETS TO BE MAINTAINED BY SAID ASSOCIATION, AND DOES ALSO HEREBY GRANT AND CONVEY TO SAID ASSOCIATION ALL THOSE PART OR PORTIONS OF SAID TRACT OF LAND DESIGNATED AND DEPICTED ON SAID PLAT AS COMMON AREAS, WHICH ARE TO BE USED FOR PRIVATE RECREATIONAL AND OPEN SPACE PURPOSES BY AND FOR THE BENEFIT OF EACH ASSOCIATION MEMBER/OWNER IN COMMON WITH ALL OTHERS IN THE SUBDIVISION, WITH SUCH COMMON AREAS TO BE MAINTAINED BY SAID ASSOCIATION, AND DOES ALSO HEREBY GRANT AND CONVEY TO SAID ASSOCIATION ALL THOSE PARTS OR PORTIONS OF SAID TRACT OF LAND DESIGNATED AND DEPICTED ON SAID PLAT AS TRAILS AND TRAIL EASEMENTS, INCLUDING ANY SUCH TRAILS OR TRAIL EASEMENTS LOCATED ON ANY COMMON AREAS OR ON ANY INDIVIDUAL LOTS, WHICH TRAILS AND TRAIL EASEMENTS ARE TO BE USED FOR PRIVATE RECREATIONAL PURPOSES BY AND FOR THE BENEFIT OF THE ASSOCIATION'S MEMBERS/OWNERS AND IN COMMON WITH ALL OTHERS IN THE SUBDIVISION, WITH SUCH TRAILS AND TRAIL EASEMENTS TO BE MAINTAINED BY SAID ASSOCIATION, AND DOES HEREBY RESERVE UNTO ITSELF, AND IT GRANTEEES AND ASSIGNS, A PERPETUAL RIGHT OF WAY OF THE PRIVET STREETS, WHICH THE UNDERSIGNED OWNER MAY GRANT AND ASSIGN TO ANY ADJOINING SUBDIVISIONS THAT MAY BE SUBDIVIDED BY SAID OWNER, ITS SUCCESSORS, OR ASSIGNS, AND ALSO GRANTS AND DEDICATES TO WEBER COUNTY A PERPETUAL OPEN SPACE RIGHT AND EASEMENT ON AND OVER THE COMMON AREAS TO GUARANTEE TO WEBER COUNTY THAT SUCH COMMON AREAS REMAIN OPEN AND UNDEVELOPED EXCEPT FOR APPROVED RECREATIONAL, PARKING AND OPEN SPACE PURPOSES, AND ALSO GRANTS AND DEDICATES A PERPETUAL RIGHT AND EASEMENT OVER, UPON AND UNDER THE LANDS DESIGNATED ON THE PLAT AS PUBLIC UTILITY, STORM WATER DETENTION PONDS AND DRAINAGE EASEMENTS, THE SAME TO BE USED FOR THE INSTALLATION, MAINTENANCE AND OPERATION OF PUBLIC UTILITY SERVICE LINES, STORM DRAINAGE FACILITIES OR FOR THE PERPETUAL PRESERVATION OF WATER DRAINAGE CHANNELS IN THEIR NATURAL STATE WHICHEVER IS APPLICABLE AS MAY BE AUTHORIZED BY THE GOVERNING AUTHORITY WITH NO BUILDINGS OR STRUCTURES BEING ERRECTED WITHIN SUCH EASEMENTS.

SIGNED THIS ____ DAY OF _____, 2022.

OSPREY RANCH, LLC

BY: JOHN LEWIS, MANAGING MEMBER

ACKNOWLEDGEMENT

STATE OF UTAH)
 COUNTY OF WEBER)

On this _____ day of _____, 2022, personally appeared before me JOHN LEWIS, whose identity is personally known to me (or proven on the basis of satisfactory evidence) and who by me duly sworn/affirmed, did say that he/she is the MANAGING MEMBER of OSPREY RANCH, LLC, and that said document was signed by him/her in behalf of said Corporation by Authority of its Bylaws, or (Resolution of its Board of Directors), and said JOHN LEWIS acknowledged to me that said Corporation executed the same.

STAMP

NOTARY PUBLIC

NOTES

- ZONE FV-3 CURRENT YARD SETBACKS: FRONT 30', SIDE 20' - SIDE FACING STREET ON CORNER 30', REAR MAIN BUILDING 30' - ACCESSORY BUILDING 10'.
- SUBJECT PROPERTY FALLS WITHIN FEMA FLOOD ZONE "X" - AREAS DETERMINED TO BE OUTSIDE THE 0.2% ANNUAL CHANCE FLOODPLAIN. PER FEMA MAP NO. 49057C0237F WITH AN EFFECTIVE DATE OF JUNE 2, 2015.

NARRATIVE

THE PURPOSE OF THIS SURVEY WAS TO CREATE A SUBDIVISION ON THE PROPERTY AS SHOWN AND DESCRIBED HEREON. THE SURVEY WAS ORDERED BY OSPREY RANCH LLC. THE CONTROL USED TO ESTABLISH THE BOUNDARY WAS THE EXISTING WEBER COUNTY SURVEY MONUMENTATION AS SHOWN AND NOTED HEREON. THE BASIS OF BEARING IS THE EAST LINE OF SECTION 33, TOWNSHIP 7 NORTH, RANGE 1 EAST, OF THE SALT LAKE BASE AND MERIDIAN WHICH BEARS NORTH 00°22'52" EAST WEBER COUNTY, UTAH NORTH, NAD 83 STATE PLANE GRID BEARING. THE RIGHT-OF-WAY OF HIGHWAY 158 WAS ESTABLISHED BY DRAWINGS RECEIVED FROM U.D.O.T. REGION 1 FEDERAL AID PROJECT H99-0158(116)0 PIN:522 DATED 4/30/2012. WARRANTY DEEDS RECORDED AS ENTRY NUMBERS 3143604, 3145237, 3145286 AND DEEDS OF ADJOINING PROPERTY OWNERS, RECORD OF SURVEY NUMBERS 1002, 293, 4608, 5102, 3584, AND THE DEDICATED PLATS OF BIG SKY ESTATES NO. 1, BIG SKY ESTATES NO. 2, BLAKE HOLLEY SUBDIVISION, EDEN ESTATES SUBDIVISION WERE ALSO USED TO DETERMINE BOUNDARY LOCATION.

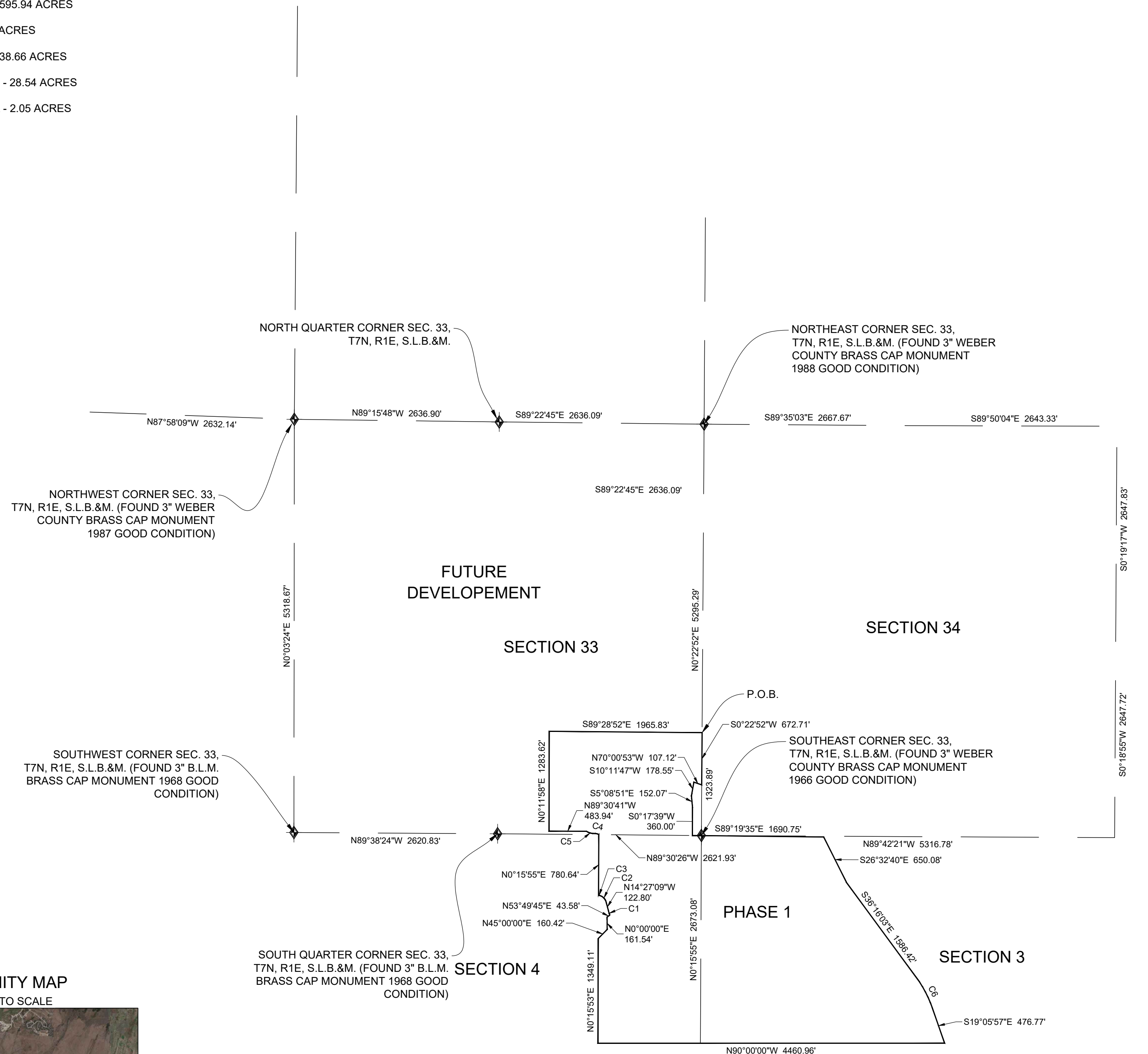

CURVE TABLE					
CURVE #	LENGTH	RADIUS	DELTA	CHORD BEARING	CHORD LENGTH
C1	47.46	159.34	17°04'00"	N19° 43' 28"W	47.29
C2	126.51	122.92	58°57'54"	N43° 34' 35"W	121.00
C3	16.92	328.00	2°57'23"	N71° 10' 07"W	16.92
C4	63.53	120.68	30°09'48"	N78° 44' 38"W	62.80
C5	101.44	167.15	34°46'15"	N73° 52' 07"W	99.89
C6	383.09	1530.00	14°20'46"	S26° 16' 20"E	382.09

VICINITY MAP

NOT TO SCALE

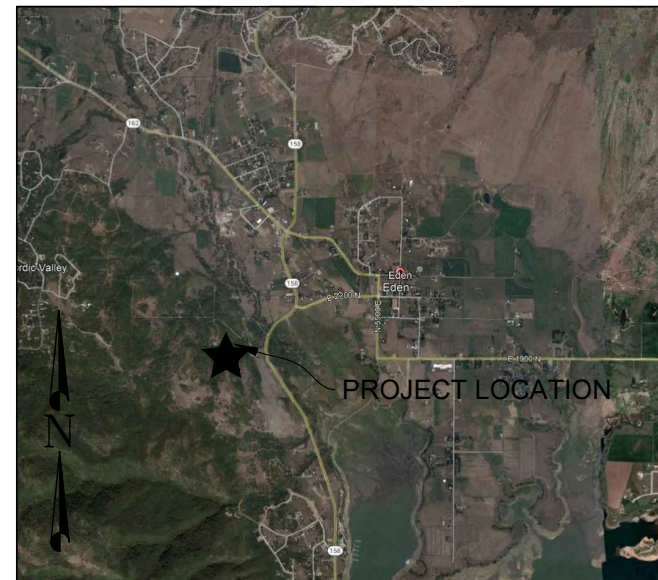

WEBER COUNTY SURVEYOR

I HEREBY CERTIFY THAT THE WEBER COUNTY SURVEYOR'S OFFICE HAS REVIEWED THIS PLAT FOR MATHEMATICAL CORRECTNESS, SECTION CORNER DATA, AND FOR HARMONY WITH LINES AND MONUMENTS ON RECORD IN COUNTY OFFICES. THE APPROVAL OF THIS PLAT BY THE WEBER COUNTY SURVEYOR DOES NOT RELIEVE THE LICENSED LAND SURVEYOR WHO EXECUTED THIS PLAT FROM THE RESPONSIBILITIES AND/OR LIABILITIES ASSOCIATED THEREWITH.

SIGNED THIS ____ DAY OF _____, 2022.

COUNTY SURVEYOR

WEBER COUNTY ATTORNEY

I HAVE EXAMINED THE FINANCIAL GUARANTEE AND OTHER DOCUMENTS ASSOCIATED WITH THIS SUBDIVISION PLAT AND IN MY OPINION THEY CONFORM WITH THE COUNTY ORDINANCE APPLICABLE THERETO AND NOW IN FORCE AND EFFECT.

SIGNED THIS ____ DAY OF _____, 2022.

COUNTY ATTORNEY

WEBER COUNTY ENGINEER

I HEREBY CERTIFY THAT THE REQUIRED PUBLIC IMPROVEMENT STANDARDS AND DRAWINGS FOR THIS SUBDIVISION CONFORM WITH COUNTY STANDARDS AND THE AMOUNT OF THE FINANCIAL GUARANTEE IS SUFFICIENT FOR THE INSTALLATION OF THESE IMPROVEMENTS.

SIGNED THIS ____ DAY OF _____, 2022.

COUNTY ENGINEER

WEBER COUNTY COMMISSION ACCEPTANCE

THIS IS TO CERTIFY THAT THIS SUBDIVISION PLAT, THE DEDICATION OF STREETS AND OTHER PUBLIC WAYS AND FINANCIAL GUARANTEE OF PUBLIC IMPROVEMENTS ASSOCIATED WITH THIS SUBDIVISION THEREON ARE HEREBY APPROVED AND ACCEPTED BY THE COMMISSIONERS OF WEBER COUNTY, UTAH.

SIGNED THIS ____ DAY OF _____, 2022.

CHAIRMAN, WEBER COUNTY COMMISSION

ATTEST: _____
NAME/TITLE

WEBER COUNTY PLANNING COMMISSION APPROVAL

THIS IS TO CERTIFY THAT THIS SUBDIVISION WAS DULY APPROVED BY THE WEBER COUNTY PLANNING COMMISSION.

SIGNED THIS ____ DAY OF _____, 2022.

CHAIRMAN, WEBER COUNTY PLANNING COMMISSION

WEBER - MORGAN HEALTH DEPARTMENT

I DO HEREBY CERTIFY THAT THE SOILS, PERCOLATION RATES, AND SITE CONDITION FOR THIS SUBDIVISION HAVE BEEN INVESTIGATED BY THIS OFFICE AND ARE APPROVED FOR ON-SITE WASTEWATER DISPOSAL SYSTEMS.

SIGNED THIS ____ DAY OF _____, 2022.

DIRECTOR WEBER-MORGAN HEALTH DEPT.

DEVELOPER: OSPREY RANCH LLC JOHN LEWIS 3718 NORTH WOLF CREEK DRIVE EDEN, UTAH, 84310 801-430-1507	S1 7	COUNTY RECORDER ENTRY NO. _____ FEE PAID _____ FILED FOR AND RECORDED _____ AT _____ IN BOOK _____ OF OFFICIAL _____ RECORDS, PAGE _____ RECORDED _____ FOR _____ COUNTY RECORDER _____ BY: _____
CIVIL & LAND PLANNING MUNICIPAL LAND SURVEYING 5150 SOUTH 875 EAST OGDEN, UT OFFICE: 801-476-0202 FAX: 801-476-0066		

OSPREY RANCH SUBDIVISION PHASE 1

LOCATED IN THE SOUTHEAST QUARTER OF SECTION 33 TOWNSHIP 7 NORTH RANGE 1 EAST AND THE NORTH HALF OF SECTIONS 3, AND 4 OF TOWNSHIP 6 NORTH, RANGE 1 WEST, SALT LAKE BASE AND MERIDIAN, WEBER COUNTY, UTAH, MAY 2022

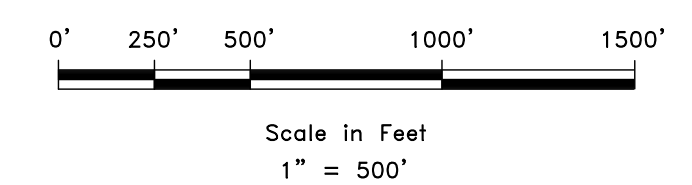
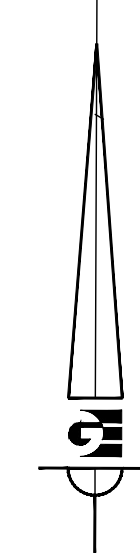
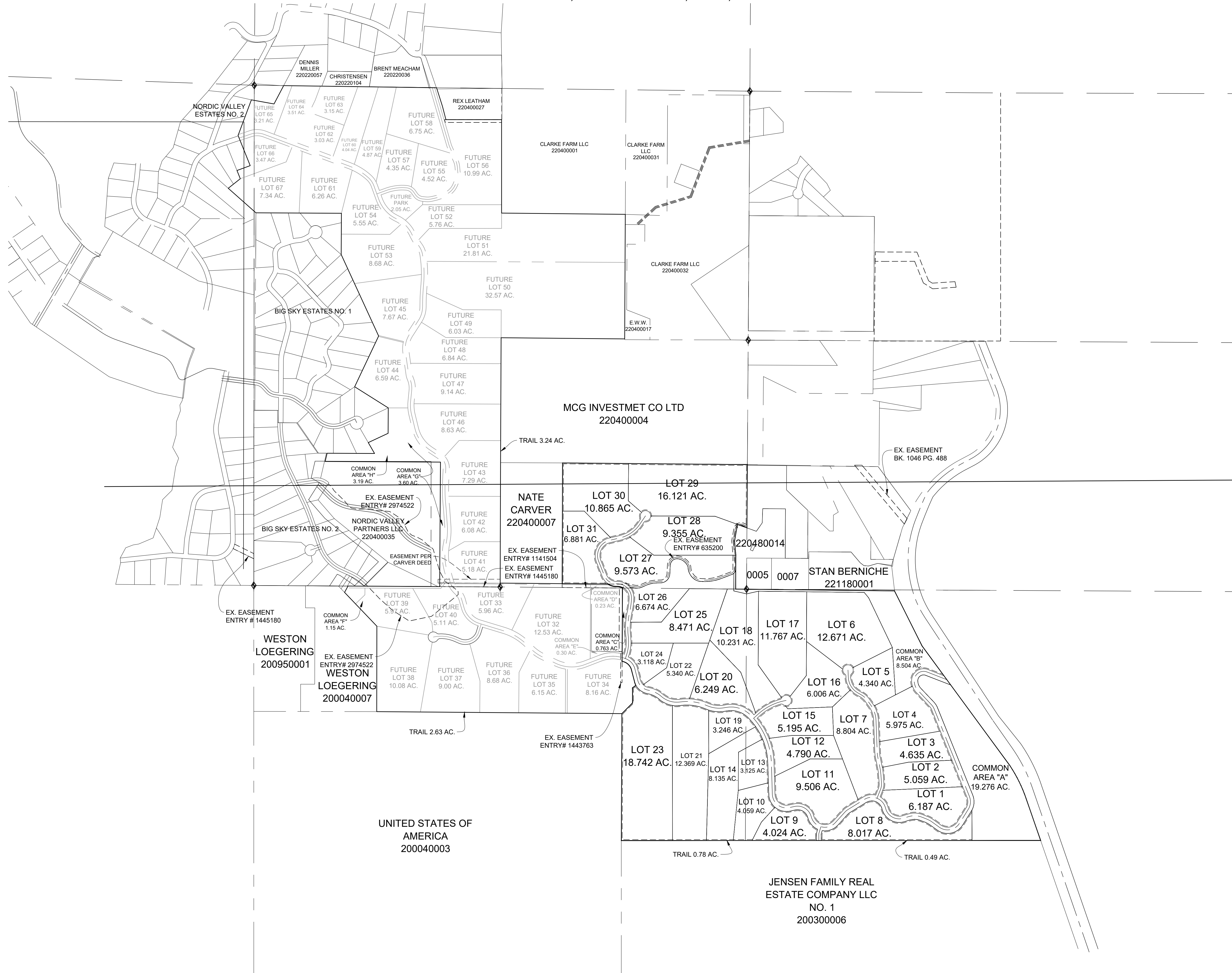

- LEGEND**
- ◆ WEBER COUNTY MONUMENT AS NOTED
 - SET 24" REBAR AND CAP MARKED GARDNER ENGINEERING
 - SUBDIVISION BOUNDARY
 - LOT LINE
 - - - ADJACENT PARCEL
 - SECTION LINE
 - - - EASEMENT
 - x EXISTING FENCE LINE

DEVELOPER: OSPREY RANCH LLC JOHN LEWIS 3718 NORTH WOLF CREEK DRIVE EDEN, UTAH, 84310 801-430-1507	S2 7	COUNTY RECORDER
		ENTRY NO. _____ FEE PAID _____ FILED FOR AND RECORDED _____ AT _____ IN BOOK _____ OF OFFICIAL RECORDS, PAGE _____ RECORDED FOR _____ COUNTY RECORDER BY: _____
CIVIL • LAND PLANNING MUNICIPAL • LAND SURVEYING 5150 SOUTH 375 EAST OGDEN, UT OFFICE: 801-476-0202 FAX: 801-476-0066		

R:\1201 - LEWIS HOMES\1201 - OSPREY RANCH SURVEY\DWG\OSPREY RANCH PHASE 1.DWG
 R:\1201 - Lewis Homes\1201 - Osprey Ranch\DWG\OSPREY RANCH PHASE 1.dwg - PLT 2, 6/14/2022 11:47:08 AM, ARCH prepared D:\2610\2400\1201\11

OSPREY RANCH SUBDIVISION PHASE 1

LOCATED IN THE SOUTHEAST QUARTER OF SECTION 33 TOWNSHIP 7 NORTH RANGE 1 EAST AND THE NORTH HALF OF SECTIONS 3, AND 4 OF TOWNSHIP 6 NORTH, RANGE 1 WEST, SALT LAKE BASE AND MERIDIAN, WEBER COUNTY, UTAH, MAY 2022

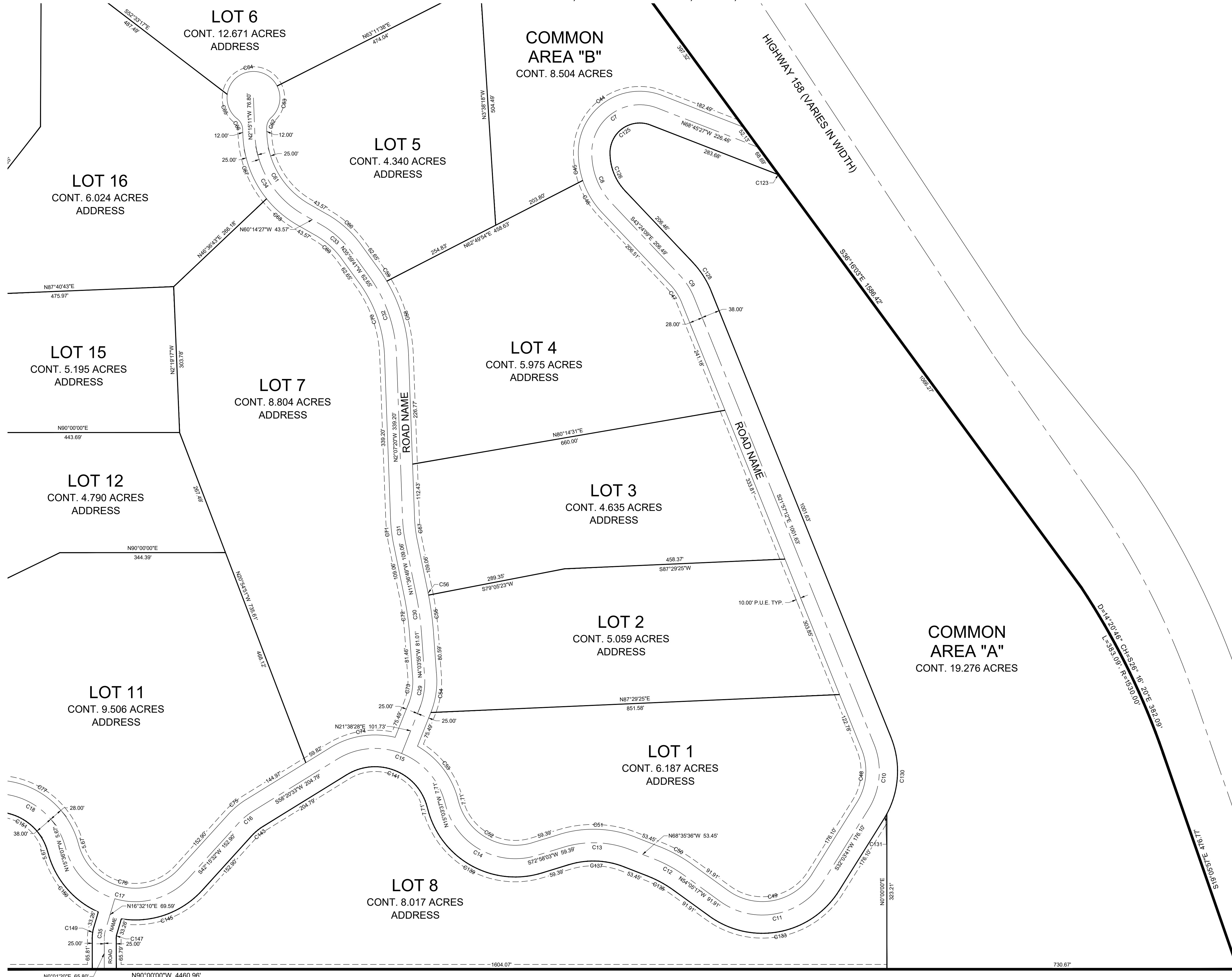

Scale in Feet
1" = 100'

LEGEND

- ◆ WEBER COUNTY MONUMENT AS NOTED
- SET 24" REBAR AND CAP MARKED GARDNER ENGINEERING
- SUBDIVISION BOUNDARY
- LOT LINE
- - - ADJACENT PARCEL
- - - SECTION LINE
- - - EASEMENT
- - - EXISTING FENCE LINE

DEVELOPER: OSPREY RANCH LLC JOHN LEWIS 3718 NORTH WOLF CREEK DRIVE EDEN, UTAH, 84310 801-430-1507	S3 7	COUNTY RECORDER ENTRY NO. _____ FEE PAID _____ FILED FOR AND RECORDED _____ AT _____ IN BOOK _____ OF OFFICIAL _____ RECORDS, PAGE _____ RECORDED _____ FOR _____ COUNTY RECORDER _____ BY: _____
		CIVIL • LAND PLANNING MUNICIPAL • LAND SURVEYING 5150 SOUTH 375 EAST OGDEN, UT OFFICE: 801-476-0202 FAX: 801-476-0066

R:\1201 - LEWIS HOMES\1205 - OSPREY RANCH SURVEY\DWG\OSPREY RANCH PHASE 1.DWG
 R:\1201 - Lewis Homes\1205 - Osprey Ranch\DWG\OSPREY RANCH PHASE 1.dwg - PLOT 3, 6/14/2022 11:47:10 AM, ARCH prepared D:\B609\2400\lhpaha.11

OSPREY RANCH SUBDIVISION PHASE 1

LOCATED IN THE SOUTHEAST QUARTER OF SECTION 33 TOWNSHIP 7 NORTH RANGE 1 EAST AND THE NORTH HALF OF SECTIONS 3, AND 4 OF TOWNSHIP 6 NORTH, RANGE 1 WEST, SALT LAKE BASE AND MERIDIAN, WEBER COUNTY, UTAH, MAY 2022

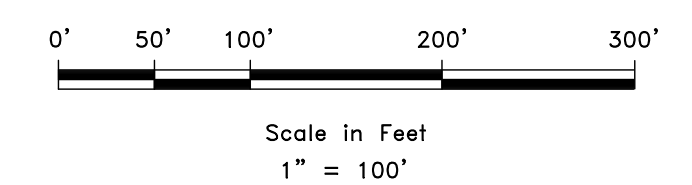
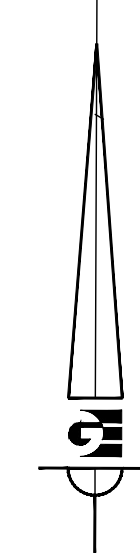
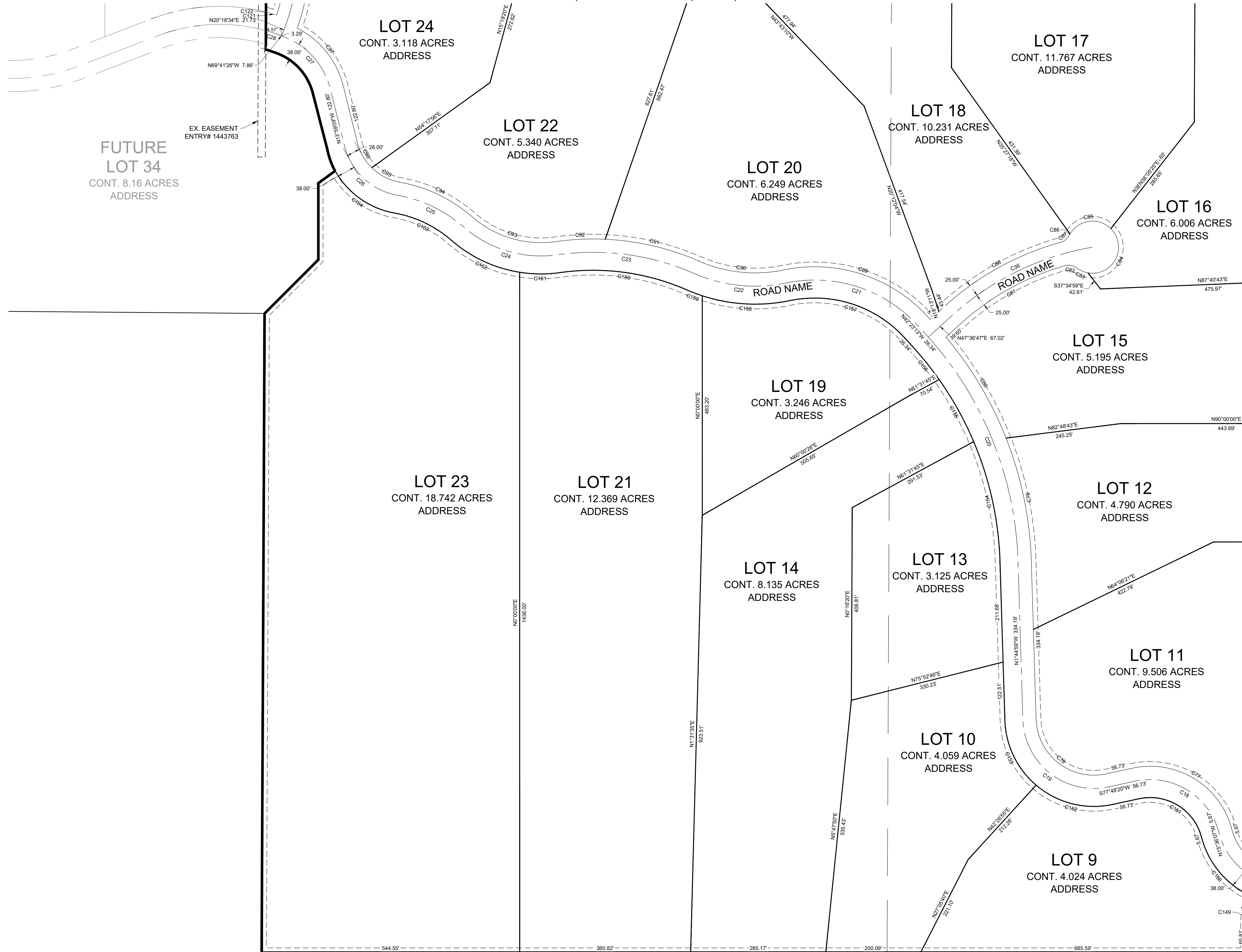

LEGEND

- WEBER COUNTY MONUMENT AS NOTED
- SET 24" REBAR AND CAP MARKED GARDNER ENGINEERING
- SUBDIVISION BOUNDARY
- LOT LINE
- ADJACENT PARCEL
- SECTION LINE
- EASEMENT
- EXISTING FENCE LINE

DEVELOPER:
OSPREY RANCH LLC
JOHN LEWIS
3718 NORTH WOLF CREEK DRIVE
EDEN, UTAH, 84310
801-430-1507

S4
7

COUNTY RECORDER
ENTRY NO. _____ FEE PAID _____
FILED FOR AND RECORDED _____
AT _____ IN BOOK _____ OF OFFICIAL
RECORDS, PAGE _____ RECORDED
FOR _____
COUNTY RECORDER
BY: _____

GARDNER ENGINEERING
CIVIL • LAND PLANNING
MUNICIPAL • LAND SURVEYING
5150 SOUTH 375 EAST OGDEN, UT
OFFICE: 801-476-0202 FAX: 801-476-0066

R:\1201 - LEWIS HOMES\1205 - OSPREY RANCH SURVEY\DWG\OSPREY RANCH PHASE 1.DWG

R:\3071 - Lewis Homes\3105 - Osprey Ranch\DWG\OSPREY RANCH PHASE 1.DWG

OSPREY RANCH SUBDIVISION PHASE 1
 LOCATED IN THE SOUTHEAST QUARTER OF SECTION 33 TOWNSHIP 7 NORTH RANGE 1 EAST AND THE
 NORTH HALF OF SECTIONS 3, AND 4 OF TOWNSHIP 6 NORTH, RANGE 1 WEST, SALT LAKE BASE AND
 MERIDIAN, WEBER COUNTY, UTAH, MAY 2022

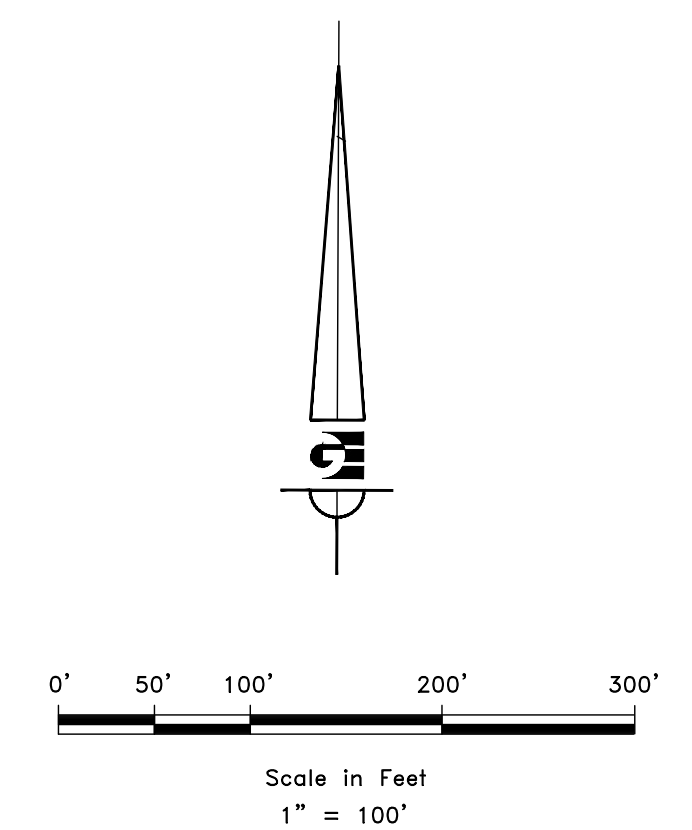
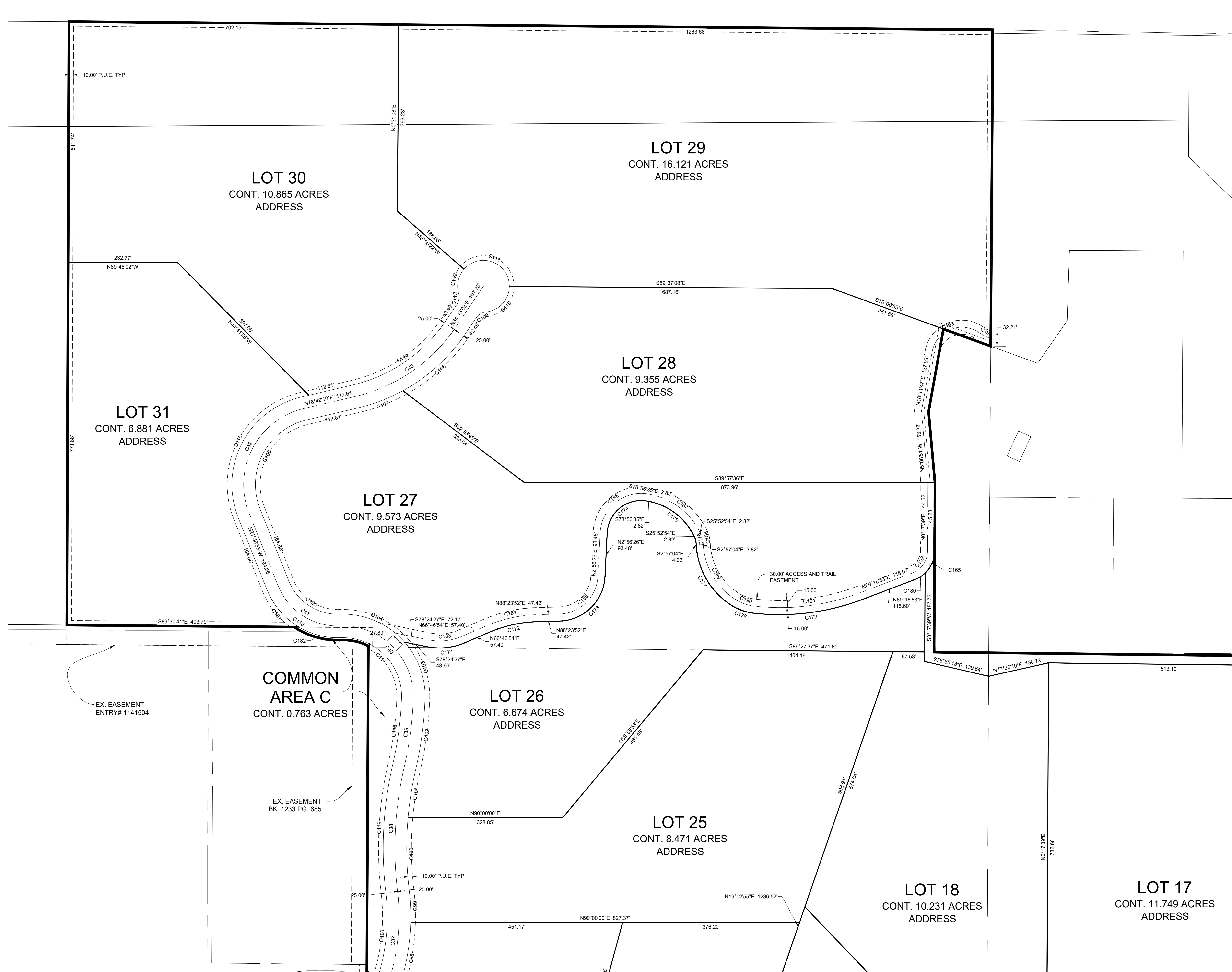

- LEGEND**
- ◆ WEBER COUNTY MONUMENT AS NOTED
 - SET 24" REBAR AND CAP MARKED GARDNER ENGINEERING
 - SUBDIVISION BOUNDARY
 - LOT LINE
 - - - ADJACENT PARCEL
 - - - SECTION LINE
 - - - EASEMENT
 - x EXISTING FENCE LINE

DEVELOPER: OSPREY RANCH LLC JOHN LEWIS 3718 NORTH WOLF CREEK DRIVE EDEN, UTAH, 84310 801-430-1507	S5 <hr/> 7	COUNTY RECORDER ENTRY NO. _____ FEE PAID _____ FILED FOR AND RECORDED _____ AT _____ IN BOOK _____ OF OFFICIAL _____ RECORDS, PAGE _____ RECORDED _____ FOR _____ COUNTY RECORDER _____ BY: _____
		<p>GARDNER ENGINEERING CIVIL • LAND PLANNING MUNICIPAL • LAND SURVEYING 5150 SOUTH 375 EAST OGDEN, UT OFFICE: 801-476-0202 FAX: 801-476-0066</p>

R:\1201 - LEWIS HOMES\1205 - OSPREY RANCH SURVEY\DWG\OSPREY RANCH PHASE 1.DWG
 R:\1201 - Lewis Homes\1205 - Osprey Ranch\DWG\OSPREY RANCH PHASE 1.dwg - Plot 5, 6/14/2022 11:47:13 AM, ARCH prepared D:\6/14/2022 2:00:18 PM, 1:1

OSPREY RANCH SUBDIVISION PHASE 1
 LOCATED IN THE SOUTHEAST QUARTER OF SECTION 33 TOWNSHIP 7 NORTH RANGE 1 EAST AND THE
 NORTH HALF OF SECTIONS 3, AND 4 OF TOWNSHIP 6 NORTH, RANGE 1 WEST, SALT LAKE BASE AND
 MERIDIAN, WEBER COUNTY, UTAH, NOVEMBER 2021

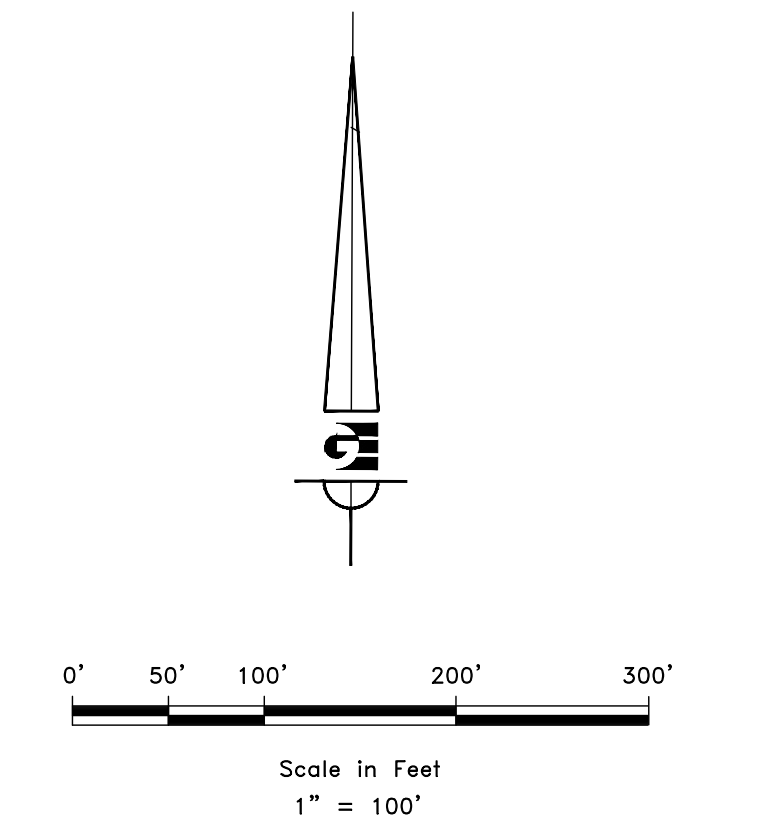
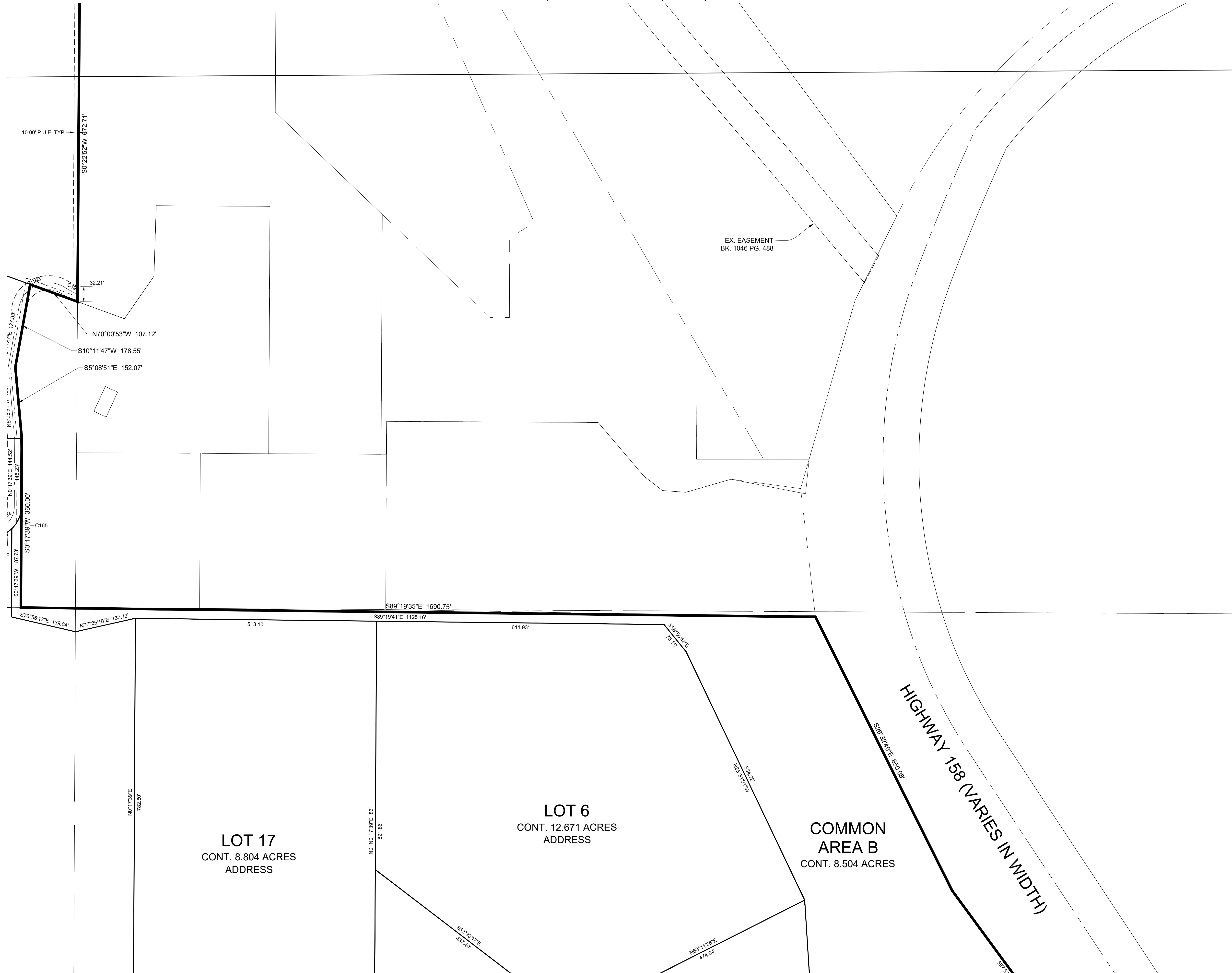

- LEGEND**
- ◆ WEBER COUNTY MONUMENT AS NOTED
 - SET 24" REBAR AND CAP MARKED GARDNER ENGINEERING
 - SUBDIVISION BOUNDARY
 - LOT LINE
 - - - ADJACENT PARCEL
 - SECTION LINE
 - - - EASEMENT
 - x EXISTING FENCE LINE

LOT 17
 CONT. 8.804 ACRES
 ADDRESS

LOT 6
 CONT. 12.671 ACRES
 ADDRESS

COMMON AREA B
 CONT. 8.504 ACRES

HIGHWAY 158 (VARIES IN WIDTH)

DEVELOPER: OSPREY RANCH LLC JOHN LEWIS 3718 NORTH WOLF CREEK DRIVE EDEN, UTAH, 84310 801-430-1507	S6 <hr/> 7	COUNTY RECORDER
		ENTRY NO. _____ FEE PAID _____ FILED FOR AND RECORDED _____ AT _____ IN BOOK _____ OF OFFICIAL RECORDS, PAGE _____ RECORDED FOR _____ COUNTY RECORDER BY: _____
<p>GARDNER ENGINEERING CIVIL • LAND PLANNING MUNICIPAL • LAND SURVEYING 5150 SOUTH 375 EAST OGDEN, UT OFFICE: 801-476-0202 FAX: 801-476-0066</p>		

R:\1201 - LEWIS HOMES\1201 - Osprey Ranch\SURV\DWG\OSPREY RANCH PHASE 1.DWG
 R:\1201 - LEWIS HOMES\1201 - Osprey Ranch\SURV\DWG\OSPREY RANCH PHASE 1.dwg Plot 6 6/14/2022 11:47:14 AM ARCH prepared D:\B66\32400\1201.dwg

OSPREY RANCH SUBDIVISION PHASE 1

LOCATED IN THE SOUTHEAST QUARTER OF SECTION 33 TOWNSHIP 7 NORTH RANGE 1 EAST AND THE NORTH HALF OF SECTIONS 3, AND 4 OF TOWNSHIP 6 NORTH, RANGE 1 WEST, SALT LAKE BASE AND MERIDIAN, WEBER COUNTY, UTAH, MAY 2022

CURVE TABLE					
CURVE #	LENGTH	RADIUS	DELTA	CHORD BEARING	CHORD LENGTH
C7	201.37	100.00	115°22'41"	S53° 33' 12"W	169.03
C8	107.97	150.67	41°03'36"	S22° 49' 43"E	105.68
C9	56.15	150.00	21°26'57"	S32° 40' 41"E	55.83
C10	141.41	150.00	54°00'53"	S5° 03' 14"W	136.23
C11	245.70	150.00	93°51'02"	S78° 59' 12"W	219.14
C12	70.89	280.00	14°30'19"	N61° 20' 27"W	70.70
C13	142.23	212.00	38°26'20"	N87° 48' 47"W	139.58
C14	240.78	150.00	91°58'19"	N61° 02' 47"W	215.75
C15	279.07	150.00	106°35'50"	N68° 21' 32"W	240.53
C16	42.11	150.00	16°05'01"	S50° 18' 02"W	41.97
C17	319.76	150.00	122°08'21"	N76° 40' 18"W	262.56
C18	226.70	150.00	86°35'33"	N58° 53' 54"W	205.73
C19	262.96	150.00	100°26'42"	N51° 58' 20"W	230.56
C20	526.98	743.00	40°38'14"	N22° 04' 06"W	516.00
C21	305.08	294.50	59°21'16"	N72° 03' 51"W	291.62
C22	199.45	323.05	35°22'29"	N84° 03' 14"W	196.30
C23	293.78	530.14	31°45'02"	N82° 14' 30"W	290.03
C24	214.11	248.87	49°17'34"	N73° 28' 14"W	207.57
C25	155.51	286.00	31°09'18"	N64° 24' 06"W	153.61
C26	162.57	141.14	65°59'36"	N46° 58' 57"W	153.73

CURVE TABLE					
CURVE #	LENGTH	RADIUS	DELTA	CHORD BEARING	CHORD LENGTH
C27	155.56	160.00	55°42'17"	N41° 50' 18"W	149.50
C28	30.51	366.00	4°46'35"	N72° 04' 44"W	30.50
C29	72.96	150.92	27°41'51"	N7° 47' 32"E	72.25
C30	86.74	658.38	7°32'54"	N7° 50' 22"W	86.67
C31	49.70	300.00	9°29'29"	N6° 52' 04"W	49.64
C32	177.36	300.00	33°52'21"	N19° 03' 30"W	174.78
C33	84.64	200.00	24°14'46"	N48° 07' 04"W	84.01
C34	202.42	200.00	57°59'16"	N51° 14' 49"W	193.89
C35	14.41	50.00	16°30'50"	N8° 16' 45"E	14.36
C36	334.78	584.25	32°49'50"	N64° 01' 42"E	330.21
C37	212.97	449.46	27°08'57"	N6° 44' 06"E	210.99
C38	267.21	768.94	19°54'37"	N3° 06' 56"E	265.86
C39	145.50	750.45	11°06'31"	N7° 30' 59"E	145.27
C40	246.31	150.00	94°04'59"	N45° 04' 46"W	219.55
C41	168.39	137.15	70°20'42"	N56° 56' 55"W	158.01
C42	285.91	166.15	98°35'43"	N27° 31' 18"E	251.92
C43	263.19	353.97	42°36'07"	N55° 31' 06"E	257.17
C44	257.30	128.00	115°10'24"	S53° 39' 21"W	216.12
C45	49.90	178.67	16°00'07"	S10° 26' 27"E	49.74
C46	77.70	178.67	24°55'01"	S30° 54' 01"E	77.09

CURVE TABLE					
CURVE #	LENGTH	RADIUS	DELTA	CHORD BEARING	CHORD LENGTH
C47	45.67	122.00	21°26'57"	S32° 40' 41"E	45.41
C48	115.01	122.00	54°00'53"	S5° 03' 14"W	110.80
C49	199.84	122.00	93°51'02"	S78° 59' 12"W	178.23
C50	77.97	308.00	14°30'19"	N61° 20' 27"W	77.77
C51	161.01	240.00	38°26'20"	N87° 48' 47"W	158.01
C52	195.84	122.00	91°58'19"	N61° 02' 47"W	175.48
C53	140.50	178.00	45°13'29"	N37° 40' 22"W	136.88
C54	84.59	175.92	27°33'02"	N7° 51' 57"E	83.78
C55	81.64	683.38	6°50'42"	N7° 29' 16"W	81.59
C56	8.39	683.38	0°42'12"	N11° 15' 43"W	8.39
C57	45.56	275.00	9°29'29"	N6° 52' 04"W	45.50
C58	162.15	325.00	28°35'09"	N16° 24' 54"W	160.47
C59	29.99	325.00	5°17'12"	N33° 21' 04"W	29.98
C60	95.21	225.00	24°14'46"	N48° 07' 04"W	94.51
C61	177.11	175.00	57°59'16"	N31° 14' 49"W	169.65
C62	26.01	30.00	49°40'47"	N22° 35' 13"E	25.21
C63	71.26	55.00	74°13'58"	N10° 18' 37"E	66.38
C64	139.69	55.00	145°30'59"	S80° 26' 09"W	105.06
C65	57.22	55.00	59°36'37"	S22° 07' 39"E	54.68
C66	26.01	30.00	49°40'47"	S27° 05' 34"E	25.21

CURVE TABLE					
CURVE #	LENGTH	RADIUS	DELTA	CHORD BEARING	CHORD LENGTH
C130	164.49	188.00	50°07'53"	S3° 06' 44"W	159.30
C131	12.74	188.00	3°53'00"	S30° 07' 11"W	12.74
C133	307.94	188.00	93°51'02"	S78° 59' 12"W	274.65
C135	61.27	242.00	14°30'19"	N61° 20' 27"W	61.10
C137	116.73	174.00	38°26'20"	N87° 48' 47"W	114.56
C139	301.78	188.00	91°58'19"	N61° 02' 47"W	270.41
C141	208.37	112.00	106°35'50"	N68° 21' 32"W	179.59
C143	31.44	112.00	16°05'01"	S50° 18' 02"W	31.34
C145	185.83	188.00	56°38'08"	S70° 34' 36"W	178.36
C147	7.21	25.00	16°30'50"	S8° 16' 45"W	7.18
C149	21.62	75.00	16°30'50"	N8° 16' 45"E	21.54
C150	164.78	188.00	50°13'12"	N40° 42' 44"W	159.56
C151	169.27	112.00	86°35'33"	N58° 53' 54"W	153.61
C152	172.70	188.00	52°37'53"	N75° 52' 44"W	166.69
C153	156.89	188.00	47°48'49"	N25° 39' 32"W	152.37
C154	261.14	705.00	21°13'24"	N12° 21' 41"W	259.65
C155	150.29	705.00	12°12'52"	N29° 04' 49"W	150.01
C156	88.59	705.00	7°11'58"	N38° 47' 14"W	88.53
C157	265.72	256.50	59°21'16"	N72° 03' 51"W	253.99
C158	187.46	361.05	29°44'56"	N86° 52' 01"W	185.36

CURVE TABLE					
CURVE #	LENGTH	RADIUS	DELTA	CHORD BEARING	CHORD LENGTH
C159	35.45	361.05	5°37'34"	N69° 10' 46"W	35.44
C160	272.72	492.14	31°45'02"	N82° 14' 30"W	269.24
C161	85.84	286.87	17°08'40"	N89° 32' 41"W	85.52
C162	160.96	286.87	32°08'54"	N64° 53' 54"W	158.86
C163	134.85	248.00	31°09'18"	N64° 24' 06"W	133.20
C164	158.94	179.14	50°50'06"	N54° 33' 42"W	153.78
C165	52.40	65.00	46°11'25"	S23° 23' 21"W	50.99
C171	81.41	134.00	34°48'39"	N84° 11' 14"E	80.17
C172	105.26	279.00	21°36'58"	N77° 35' 23"E	104.64
C173	148.41	99.50	85°27'27"	N45° 40' 09"E	135.03
C174	123.98	72.40	98°07'00"	N51° 59' 55"E	109.38
C175	125.02	135.00	53°03'41"	S52° 24' 44"E	120.60
C176	14.55	35.00	23°48'55"	S13° 58' 26"E	14.44
C177	150.13	162.79	52°50'24"	S30° 04' 34"E	144.87
C178	56.56	115.01	28°10'38"	S70° 35' 08"E	55.99
C179	235.90	496.27	27°14'06"	N82° 23' 14"E	233.68
C180	25.86	65.00	22°47'50"	N57° 52' 59"E	25.69
C181	106.24	162.15	37°32'20"	S40° 32' 43"E	104.35
C182	92.84	162.15	32°48'22"	S75° 43' 04"E	91.58
C183	72.30	119.00	34°48'39"	N84° 11' 14"E	71.19

CURVE TABLE					
CURVE #	LENGTH	RADIUS	DELTA	CHORD BEARING	CHORD LENGTH
C67	143.41	225.00	36°31'07"	S20° 30' 44"E	140.99
C68	84.31	225.00	21°28'10"	S49° 30' 22"E	83.82
C69	74.06	175.00	24°14'46"	S48° 07' 04"E	73.50
C70	162.58	275.00	33°52'21"	S19° 03' 30"E	160.22
C71	53.84	325.00	9°29'29"	S6° 52' 04"E	53.78
C72	83.44	633.38	7°32'54"	S7° 50' 22"E	83.38
C73	61.29	125.92	27°53'10"	S7° 41' 53"W	60.68
C74	140.50	178.00	45°13'29"	S80° 57' 17"W	136.88
C75	49.97	178.00	16°05'01"	S50° 18' 02"W	49.80
C76	260.07	122.00	122°08'21"	N76° 40' 18"W	213.55
C77	269.02	178.00	86°35'33"	N58° 53' 54"W	244.13
C78	213.88	122.00	100°26'42"	N51° 58' 20"W	187.52
C79	265.89	771.00	19°45'33"	N11° 37' 45"W	264.57
C80	249.08	771.00	18°30'37"	N30° 45' 50"W	248.00
C81	255.24	559.25	26°08'57"	N60° 41' 16"E	253.03
C82	27.80	30.00	53°06'11"	S79° 41' 11"E	26.82
C83	26.03	55.00	27°06'59"	S66° 41' 35"E	25.79
C84	139.33	55.00	145°08'44"	N27° 10' 33"E	104.95
C85	100.00	55.00	104°10'27"	S82° 30' 58"W	86.78
C86	2.66	55.00	2°46'23"	S29° 02' 33"W	2.66

CURVE TABLE					
CURVE #	LENGTH	RADIUS	DELTA	CHORD BEARING	CHORD LENGTH
C87	24.46	30.00	46°42'32"	S51° 00' 37"W	23.79
C88	284.46	609.25	26°45'06"	S60° 59' 20"W	281.89
C89	334.09	322.50	59°21'16"	N72° 03' 51"W	319.35
C90	182.17	295.05	35°22'29"	N84° 03' 14"W	179.29
C91	204.63	558.14	21°00'22"	N76° 52' 10"W	203.48
C92	104.67	558.14	10°44'40"	S87° 15' 19"W	104.51
C93	190.02	220.87	49°17'34"	N73° 28' 14"W	184.21
C94	170.74	314.00	31°09'18"	N64° 24' 06"W	168.64
C95	68.24	113.14	34°33'22"	N62° 42' 04"W	67.21
C96	62.08	113.14	31°26'14"	N29° 42' 16"W	61.30
C97	161.04	188.00	49°04'48"	N38° 31' 33"W	156.16
C98	150.76	474.46	18°12'21"	N10° 35' 29"E	150.13
C99	68.97	474.46	8°19'42"	N2° 40' 32"W	68.91
C100	153.93	743.94	11°51'19"	N0° 54' 43"W	153.66
C101	104.59	743.94	8°03'18"	N9° 02' 35"E	104.50
C102	150.35	775.45	11°06'31"	N7° 30' 59"E	150.11
C103	132.15	175.00	43°15'58"	N19° 40' 16"W	129.03
C104	155.21	175.00	50°49'01"	N66° 42' 45"W	150.17
C105	137.69	112.15	70°20'42"	N56° 56' 55"W	129.21
C106	242.89	141.15	98°35'43"	N27° 31' 18"E	214.01

CURVE TABLE					
CURVE #	LENGTH	RADIUS	DELTA	CHORD BEARING	CHORD LENGTH
C107	102.24	378.97	15°27'29"	N69° 05' 25"E	101.93
C108	179.54	378.97	27°08'38"	N47° 47' 22"E	177.86
C109	26.01	30.00	49°40'47"	N59° 03' 26"E	25.21
C110	80.17	55.00	83°30'58"	N42° 08' 21"E	73.26
C111	133.64	55.00	139°13'14"	N69° 13' 45"W	103.11
C112	54.35	55.00	56°37'23"	S12° 50' 57"W	52.17
C113	26.01	30.00	49°40'47"	S9° 22' 39"W	25.21
C114	244.60	328.97	42°36'07"	S55° 31' 06"W	239.01
C115	328.93	191.15	98°35'43"	S27° 31' 18"W	289.82
C116	199.08	162.15	70°20'42"	S56° 56' 55"E	186.81
C117	205.26	125.00	94°04'59"	S45° 04' 46"E	182.96
C118	140.65	725.45	11°06'31"	S7° 30' 59"W	140.43
C119	275.89	793.94	19°54'37"		