

# OSPREY RANCH

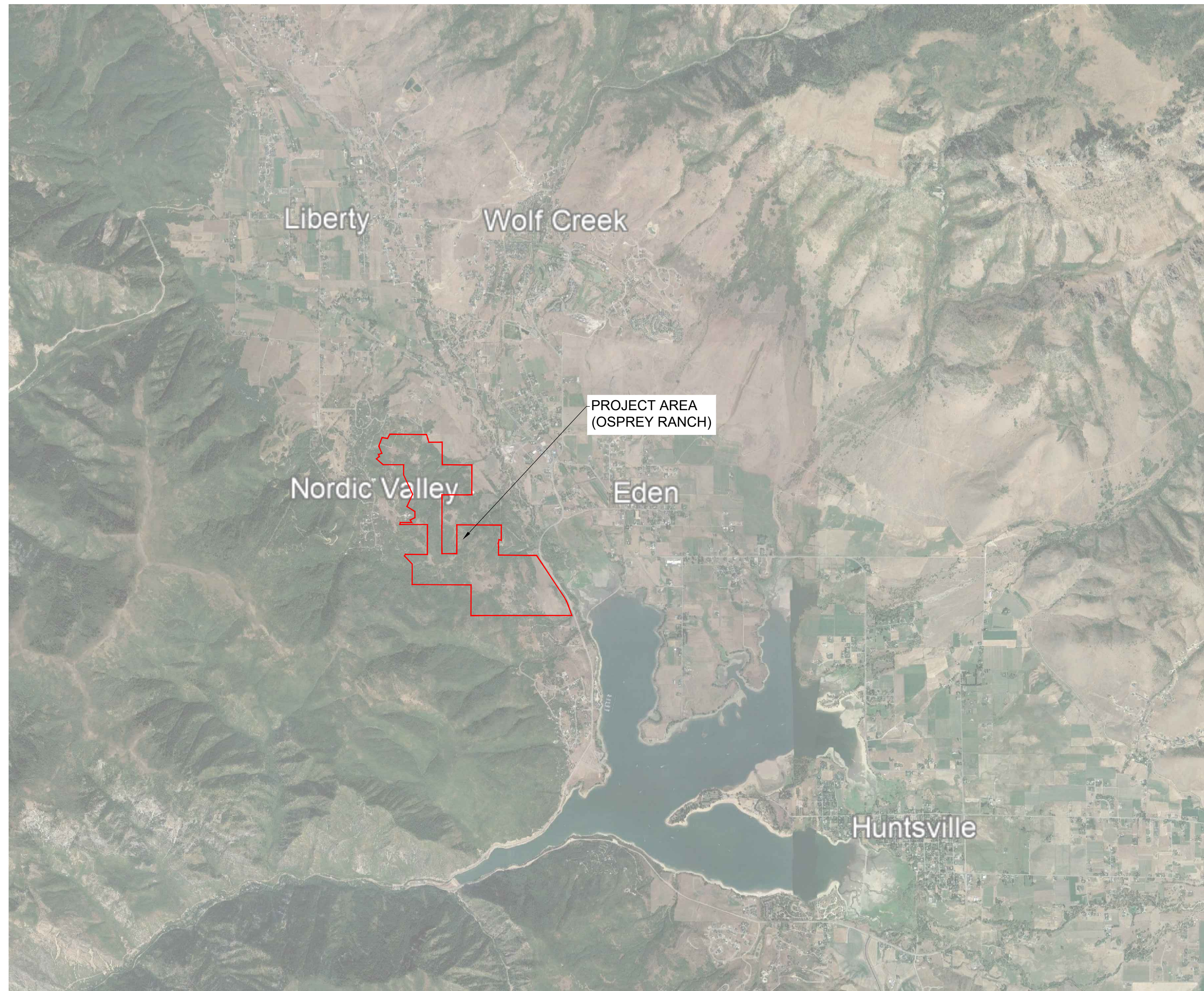

PRELIMINARY SUBMITTAL  
WEBER COUNTY, UTAH

## LOCATION MAP



## OSPREY RANCH

### PREPARED FOR:

OSPREY RANCH LLC.  
JOHN LEWIS/SHANE DUNLEAVY  
3718 N WOLF CREEK DR  
EDEN, UTAH 84310  
801.430.1507 - 801.979.7989

### CONSULTANTS:



LANDSCAPE ARCHITECT  
LANGVARDT DESIGN GROUP  
328 WEST, 200 SOUTH, SUITE 102  
SALT LAKE CITY, UTAH 84101  
801.583.1295



ENGINEER:  
GARDNER ENGINEERING  
RYAN CHRISTENSEN  
968 CHAMBERS STREET, SUITE 5  
SOUTH OGDEN, UTAH 84403  
801.476.0202



PROJECT MANAGEMENT:  
THE HOUSEHOLDER GROUP  
ERIC HOUSEHOLDER  
2850 NORTH NORDIC VALLEY DRIVE  
EDEN, UTAH 84310  
801.389.0040

### SHEET INDEX:

- C-01 COVER SHEET
- SA1 SLOPE ANALYSIS
- PH1 PHASING PLAN
- TS1 TYPICAL SECTIONS AND NOTES
- SP1 SITE PLAN - PHASE 1
- UM1 UTILITY MASTER PLAN
- UT1-3 UTILITY SHEETS - PHASE 1
- DR1 DRAINAGE MASTER PLAN
- DR2 DRAINAGE CALCULATIONS
- DR3 DRAINAGE CALCULATIONS
- DR4 DRAINAGE PROFILES
- DR5 DRAINAGE PROFILES
- SW1 SWPPP
- PP0 PLAN AND PROFILE KEY MAP
- PP1-15 PLAN AND PROFILE SHEETS
- PS1-PS6 SEWER PLAN AND PROFILE

### DETAILS:

- DT1 WATER TANK DETAIL - NOT INCLUDED WITH THIS SET
- DT2 WATER TANK DETAILS - NOT INCLUDED WITH THIS SET
- DT3 ALTITUDE VALVE DETAIL
- DT4 WATER DETAILS
- DT5 SEWER DETAILS

OSPREY RANCH  
PRELIMINARY SUBMITTAL - PHASE 1

June 6, 2022

# SLOPE ANALYSIS OSPREY RANCH

Slopes Table				
Number	Minimum Slope	Maximum Slope	Area - AC	Color
1	25.00%	40.00%	148.42	Red
2	40.00%	300.00%	62.12	Blue

 R-LOTS

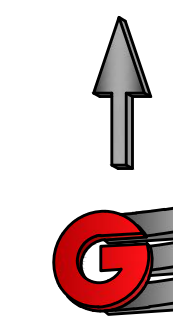
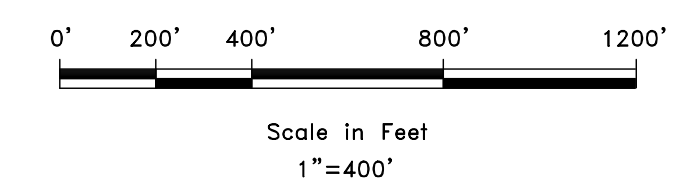
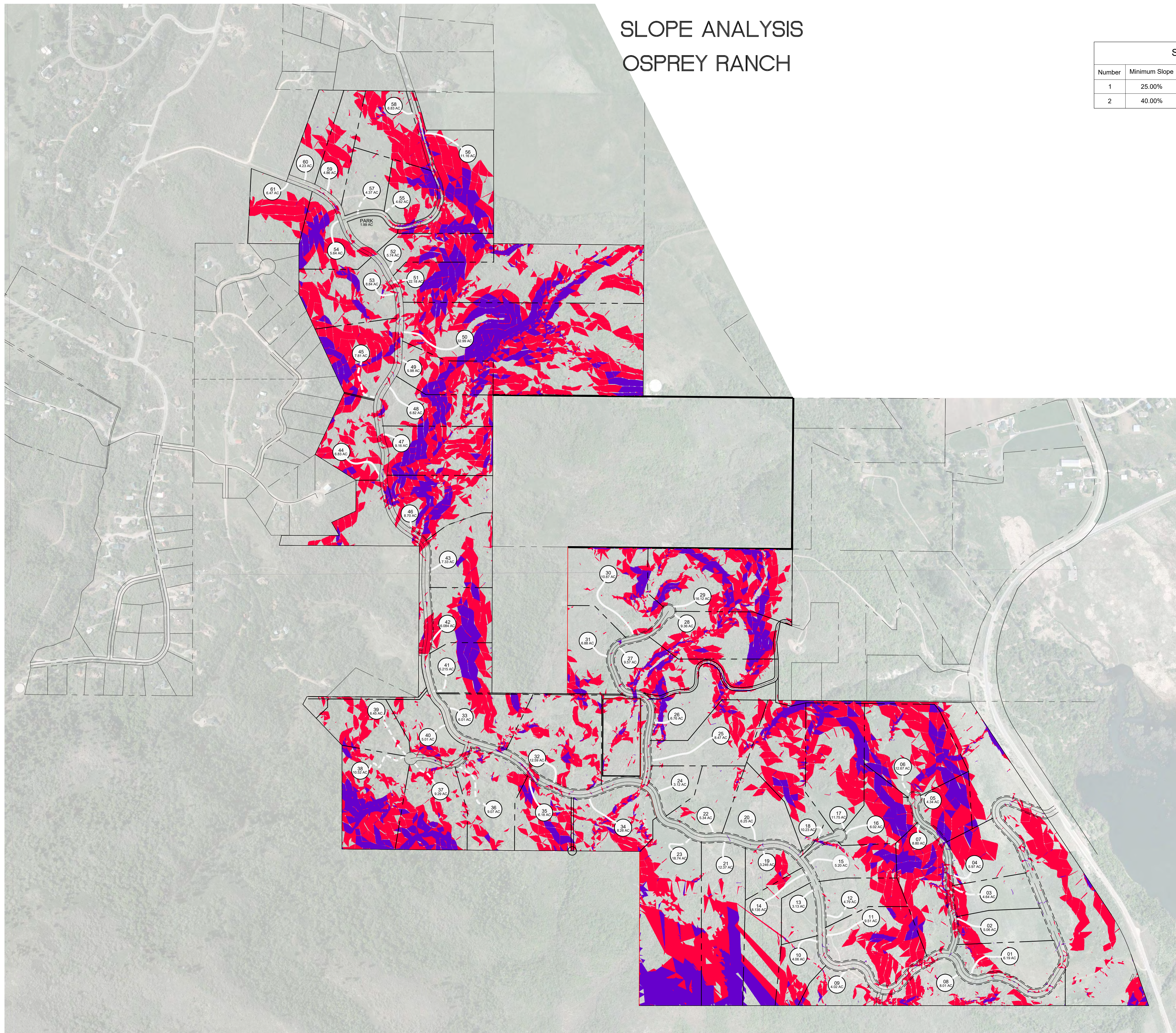

REVISIONS	
DATE	DESCRIPTION

SCALE: 1"=400'  
DATE: 06-07-22  
DESIGN: KAN  
DRAWN: KAN  
CHECKED: RC

SLOPE ANALYSIS  
OSPREY RANCH  
UT-158  
EDEN, WEBER, UTAH

**GARDNER ENGINEERING**  
CIVIL • LAND PLANNING  
MUNICIPAL • LAND SURVEYING  
51150 SOUTH 375 EAST OGDEN, UT  
OFFICE: 801-476-0202 FAX: 801-476-0066

SA1

A:\1251 - LEWIS HOMES\1251 - OSPREY RANCH\DESIGN\OSPREY RANCH SLOPE ANALYSIS 2 COLORS 06-03-22.DWG

# PHASING PLAN OSPREY RANCH

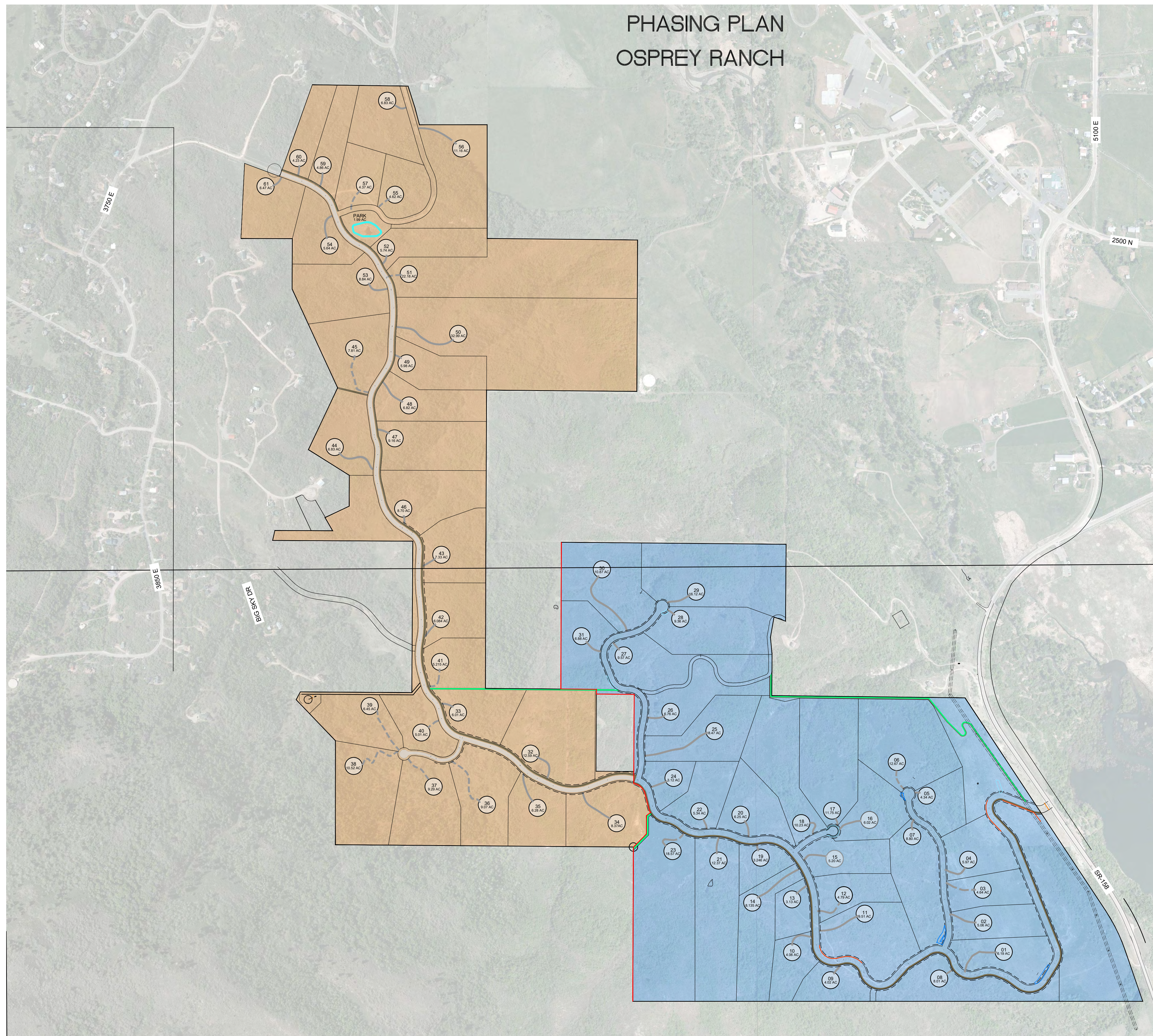

- PHASE 1 - 286.07 ACRES (31 LOTS)
- PHASE 2 - 280.90 ACRES (30 LOTS)

**SITE DATA:**

TOTAL AREA	566.97 ACRES
EXISTING ZONE FV-3	
ROAD ROW	30.06 ACRES
SLOPES OVER 40%	62.12 ACRES
STREAM CORRIDOR	16.15 ACRES
NET DEVELOPABLE AREA	458.64 ACRES
PROPOSED UNITS	61 UNITS
PROPOSED NET DENSITY	1 UNIT/ 7.52 ACRES

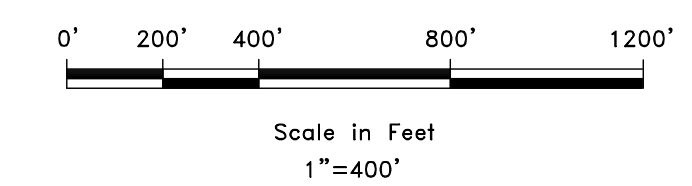
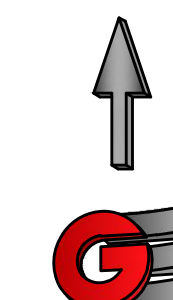

REVISIONS	
DATE	DESCRIPTION

SCALE: 1"=400'
DATE: 06-08-22
DESIGN: KAN
DRAWN: KAN
CHECKED: RC

PHASING PLAN  
OSPREY RANCH  
UT-158  
EDEN, WEBER, UTAH

**GARDNER  
ENGINEERING**

CIVIL • LAND PLANNING  
MUNICIPAL • LAND SURVEYING

51150 SOUTH 375 EAST OGDEN, UT  
OFFICE: 801-476-0202 FAX: 801-476-0066

PH1

## GENERAL NOTES

1. ALL MATERIALS, WORKMANSHIP AND CONSTRUCTION OF SITE IMPROVEMENTS SHALL MEET OR EXCEED THE STANDARDS AND SPECIFICATIONS SET FORTH BY THE ENGINEER, PLANNING, CODES AND SPECIFICATIONS AND APPLICABLE COUNTY, STATE AND FEDERAL REGULATIONS. WHERE THERE IS CONFLICT BETWEEN THESE PLANS AND SPECIFICATIONS, OR ANY APPLICABLE STANDARDS, THE HIGHER QUALITY STANDARD SHALL APPLY.
2. THE CONTRACTOR IS SPECIFICALLY CAUTIONED THAT THE LOCATION AND OR ELEVATION OF EXISTING UTILITIES, AS SHOWN ON THESE PLANS IS BASED ON RECORDS OF THE VARIOUS UTILITY COMPANIES AND WHERE POSSIBLE, MEASUREMENTS TAKEN IN THE FIELD. THE INFORMATION IS NOT TO BE RELIED UPON AS BEING EXACT OR COMPLETE. THE CONTRACTOR MUST CALL THE LOCAL UTILITY LOCATION CENTER AT LEAST 48 HOURS BEFORE ANY EXCAVATION TO REQUEST EXACT FIELD LOCATIONS OF THE UTILITIES. PRIOR TO CONSTRUCTION, THE CONTRACTOR SHALL VERIFY PERTINENT LOCATIONS AND ELEVATIONS, ESPECIALLY AT THE CONNECTION POINTS AND AT POTENTIAL UTILITY CONFLICTS. IT SHALL BE THE RESPONSIBILITY OF THE CONTRACTOR TO RELOCATE ALL EXISTING UTILITIES THAT CONFLICT WITH THE PROPOSED IMPROVEMENTS SHOWN ON THESE PLANS.
3. THE CONTRACTOR IS RESPONSIBLE FOR OBTAINING ALL NECESSARY PERMITS FROM ALL APPLICABLE AGENCIES. THE CONTRACTOR SHALL NOTIFY THE DESIGNATED PUBLIC WORKS INSPECTOR AT LEAST 48 HOURS PRIOR TO THE START OF ANY EARTH DISTURBING ACTIVITY, OR CONSTRUCTION ON ANY AND ALL PUBLIC IMPROVEMENTS.
4. THE CONTRACTOR SHALL COORDINATE AND COOPERATE WITH THE CITY AND ALL UTILITY COMPANIES INVOLVED WITH REGARD TO RELOCATIONS OR ADJUSTMENTS OF EXISTING UTILITIES DURING CONSTRUCTION AND TO ASSURE THAT THE WORK IS ACCOMPLISHED IN A TIMELY FASHION AND WITH A MINIMUM DISRUPTION OF SERVICE.
5. THE CONTRACTOR SHALL HAVE ONE (1) COPY OF APPROVED PLANS, AND ONE (1) COPY OF THE APPROPRIATE STANDARDS AND SPECIFICATIONS AND A COPY OF ANY PERMITS AND EXTENSION AGREEMENTS NEEDED FOR THE JOB, ON SITE AT ALL TIMES.
6. THE CONTRACTOR SHALL BE RESPONSIBLE FOR ALL ASPECTS OF SAFETY INCLUDING BUT NOT LIMITED TO, EXCAVATION, TRENCHING, SHORING, TRAFFIC CONTROL, AND SECURITY.
7. IF DURING THE CONSTRUCTION PROCESS CONDITIONS ARE ENCOUNTERED BY THE CONTRACTOR, HIS SUBCONTRACTORS, OR OTHER AFFECTED PARTIES, WHICH COULD INDICATE A SITUATION THAT IS NOT IDENTIFIED IN THE PLANS OR SPECIFICATIONS, THE CONTRACTOR SHALL CONTACT THE ENGINEER IMMEDIATELY.
8. THE CONTRACTOR IS RESPONSIBLE FOR PROVIDING ALL LABOR AND MATERIALS NECESSARY FOR THE COMPLETION OF THE INTENDED IMPROVEMENTS SHOWN ON THESE DRAWINGS OR DESIGNATED TO BE PROVIDED, INSTALLED, CONSTRUCTED, REMOVED AND RELOCATED UNLESS SPECIFICALLY NOTED OTHERWISE.
9. THE CONTRACTOR SHALL BE RESPONSIBLE FOR KEEPING ROADWAYS FREE AND CLEAR OF ALL CONSTRUCTION DEBRIS AND DIRT TRACKED FROM THE SITE.
10. THE CONTRACTOR SHALL BE RESPONSIBLE FOR RECORDING AS-BUILT DRAWINGS ON A SET OF RECORD DRAWINGS KEPT AT THE CONSTRUCTION SITE, AND AVAILABLE TO THE COUNTY INSPECTOR AT ALL TIMES.
11. THE CONTRACTOR SHALL SEQUENCE INSTALLATION OF UTILITIES IN SUCH A MANNER AS TO MINIMIZE POTENTIAL UTILITY CONFLICTS. IN GENERAL, STORM SEWER AND SANITARY SEWER SHOULD BE CONSTRUCTED PRIOR TO INSTALLATION OF WATER LINES AND DRY UTILITIES.
12. IT SHALL BE THE RESPONSIBILITY OF THE CONTRACTOR TO COORDINATE ALL UTILITY RELOCATIONS CONSISTENT WITH THE CONTRACTORS SCHEDULE FOR THIS PROJECT, WHETHER SHOWN OR NOT SHOWN AS IT RELATES TO THE CONSTRUCTION ACTIVITIES CONTEMPLATED IN THESE PLANS.

## UTILITY DISCLAIMER

THE CONTRACTOR IS SPECIFICALLY CAUTIONED THAT EXISTING UNDERGROUND UTILITIES AND IMPROVEMENTS ARE SHOWN IN THEIR APPROXIMATE LOCATIONS BASED UPON RECORD INFORMATION AVAILABLE AT THE TIME OF PREPARATION OF PLANS. LOCATIONS MAY NOT HAVE BEEN VERIFIED IN THE FIELD AND NO GUARANTEE IS MADE AS TO ACCURACY OR COMPLETENESS OF THE INFORMATION SHOWN. IT SHALL BE RESPONSIBILITY OF THE CONTRACTOR TO DETERMINE THE EXISTENCE AND LOCATION OF THOSE UTILITIES SHOWN ON THESE PLANS OR INDICATED IN THE FIELD BY LOCATING SERVICES. ANY ADDITIONAL COSTS INCURRED AS A RESULT OF CONTRACTOR'S FAILURE TO VERIFY LOCATIONS OF EXISTING UTILITIES PRIOR TO BEGINNING OF CONSTRUCTION IN THEIR VICINITY SHALL BE BORNE BY THE CONTRACTOR AND ASSUMED INCLUDED IN THE CONTRACT.

## NOTICE TO CONTRACTOR

ALL CONTRACTORS AND SUBCONTRACTORS PERFORMING WORK SHOWN ON OR RELATED TO THESE PLANS SHALL CONDUCT THEIR OPERATIONS SO THAT ALL EMPLOYEES ARE PROVIDED A SAFE PLACE TO WORK AND THE PUBLIC IS PROTECTED. ALL CONTRACTORS AND SUBCONTRACTORS SHALL COMPLY WITH THE "OCCUPATIONAL SAFETY AND HEALTH REGULATIONS" OF THE U.S. DEPARTMENT OF LABOR AND THE STATE OF UTAH DEPARTMENT OF INDUSTRIAL RELATIONS CONSTRUCTION SAFETY ORDERS" THE CIVIL ENGINEER SHALL NOT BE RESPONSIBLE IN ANY WAY FOR CONTRACTORS AND SUBCONTRACTORS COMPLIANCE WITH SAID REGULATIONS AND ORDERS.

CONTRACTOR FURTHER AGREES THAT HE SHALL ASSUME SOLE AND COMPLETE RESPONSIBILITY FOR JOB-SITE CONDITIONS DURING THE COURSE OF CONSTRUCTION OF THIS PROJECT, INCLUDING SAFETY OF ALL PERSONS AND PROPERTY, THAT THIS REQUIREMENT SHALL APPLY CONTINUOUSLY AND NOT BE LIMITED TO NORMAL WORKING HOURS. AND THAT THE CONTRACTOR SHALL DEFEND, INDEMNIFY AND HOLD THE OWNER AND THE CIVIL ENGINEER HARMLESS FROM ANY AND ALL LIABILITY, REAL OR ALLEGED IN CONNECTION WITH THE PERFORMANCE OF WORK ON THIS PROJECT, EXCEPTING FOR LIABILITY ARISING FROM THE SOLE NEGLIGENCE OF THE OWNER OR ENGINEER.

## SWPPP GENERAL NOTES

1. CONTRACTOR SHALL OBTAIN ALL NECESSARY UPDES PERMITS AS REQUIRED BY THE COUNTY ENGINEERING DEPARTMENT AND UTAH STATE DEPT. OF ENV. QUALITY.
2. ALL STRUCTURAL EROSION MEASURES SHALL BE INSTALLED AS SHOWN ON THE SWPPP PLAN, PRIOR TO ANY OTHER GROUND-DISTURBING ACTIVITY. ALL EROSION CONTROL MEASURES SHALL BE MAINTAINED IN GOOD REPAIR BY THE CONTRACTOR, UNTIL SUCH TIME AS THE ENTIRE DISTURBED AREAS ARE STABILIZED WITH HARD SURFACE OR LANDSCAPING.
3. INSPECTION TO BE PERFORMED WEEKLY BY A RSI OR OTHER CERTIFIED INSPECTOR.

## CULINARY WATER GENERAL NOTES

1. ALL INSTALLATION AND MATERIALS INSTALLED SHALL BE NEW AND CONFORM TO EDEN WATER COMPANY STANDARDS, SPECIFICATIONS AND PLANS.
2. ALL INTERIOR SURFACES AND COATINGS SHALL COMPLY WITH ANS/NSF STANDARD 61 OR OTHER STANDARDS APPROVED BY THE DIRECTOR. THIS REQUIREMENT APPLIES TO ANY PIPES AND FITTINGS, PROTECTIVE MATERIALS (E.G., PAINTS, COATINGS, CONCRETE ADMIXTURES, CONCRETE RELEASE AGENTS, OR CONCRETE SEALERS), JOINING AND SEALING MATERIALS (E.G., ADHESIVES, CAULKS, GASKETS, PRIMERS AND SEALANTS) AND MECHANICAL DEVICES (E.G., ELECTRICAL WIRE, SWITCHES, SENSORS, VALVES, OR SUBMERSIBLE PUMPS) THAT MAY COME INTO CONTACT WITH THE DRINKING WATER.
3. THE CURRENT REQUIREMENTS OF THE UTAH DIVISION OF DRINKING WATER, GOVERNING THE MATERIALS AND INSTALLATION USED IN THE PROJECT SHALL BE MET.
4. THRUST BLOCKING AND MECHANICAL RESTRAINTS ARE REQUIRED AT ALL BENDS AND FITTINGS.
5. ALL WATERLINES AT SEWER CROSSINGS SHALL BE LOCATED ABOVE AND HAVE AN 18-INCH VERTICAL SEPARATION FROM THE SEWER PIPE. IF THIS IS NOT PROVIDED, CARE SHALL BE TAKEN TO ENSURE, THERE ARE NO JOINTS IN EITHER PIPE WITHIN 20' OF THE POINT AT WHICH THE PIPES CROSS EACH OTHER, EITHER THROUGH INSTALLING THE PIPES IN CASINGS OR BY PLACEMENT OF JOINTS.
6. DISINFECTION TESTS SHALL BE PERFORMED BY THE WATER UTILITY WITH COOPERATION FROM THE CONTRACTOR IN PERFORMING ANY NECESSARY EXCAVATION AND SUBSEQUENT BACKFILLING AT NO COST TO THE COUNTY.
7. CHLORINATION OF COMPLETED WATER LINE. THE NEW WATER LINES SHALL BE DISINFECTED BY CHLORINATION IN ACCORDANCE WITH AWWA STANDARD C651-14. THE CONTRACTOR WILL BE RESPONSIBLE FOR ALL RELATED COSTS AND FEES RELATED TO THE CHLORINATION OF THE COMPLETED WATER LINE. THIS TEST SHALL BE PERFORMED PRIOR TO CONNECTION OF THE NEW WATER LINES TO THE EXISTING WATER SYSTEM. THE CONTRACTOR SHALL NOTIFY THE WATER UTILITY AT LEAST 24 HOURS BEFORE THE CHLORINATION IS DESIRED.
8. A MINIMUM HORIZONTAL CLEARANCE OF 10 FEET SHALL BE MAINTAINED FROM SANITARY SEWER MAINS.
9. UNLESS OTHERWISE SPECIFIED, ALL WATERLINES SHALL BE AWWA DUCTILE IRON PC 250 AND SHALL BE PRESSURE TESTED AT 200 PSI FOR AT LEAST 2 HOUR.
10. CONTRACTOR SHALL LOCATE VALVES PRIOR TO CONNECTION WITH EXISTING SYSTEM, BUT SHALL NOT OPERATE ANY VALVE WITHOUT PERMISSION FROM THE WATER UTILITY.
11. ALL WATER MAINS, VALVES, FIRE HYDRANTS, SERVICES AND APPURTENANCES SHALL BE INSTALLED, TESTED, AND APPROVED PRIOR TO COMMISSIONING TANK.
12. THE WATER UTILITY REQUIRES THE USE OF CORROSION RESISTANT MATERIALS FOR ALL CULINARY WATER IMPROVEMENTS. SPECIFICALLY, TRIPAC BLUE BOLTS OR STAINLESS STEEL BOLTS MUST BE USED ON ALL FITTINGS. FURTHER, ALL METAL FITTINGS SHALL BE POLY WRAPPED.

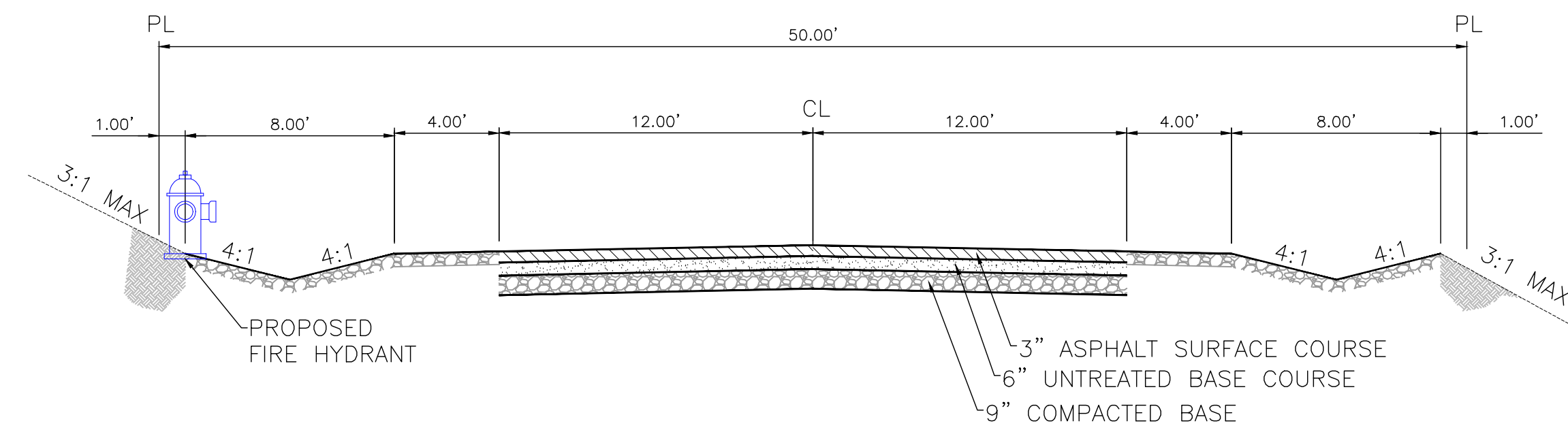

TYPICAL ROAD SECTION - 50 ROW

NOT TO SCALE  
ROAD 2  
ROAD 3  
ROAD 4  
ROAD 5  
ROAD 6

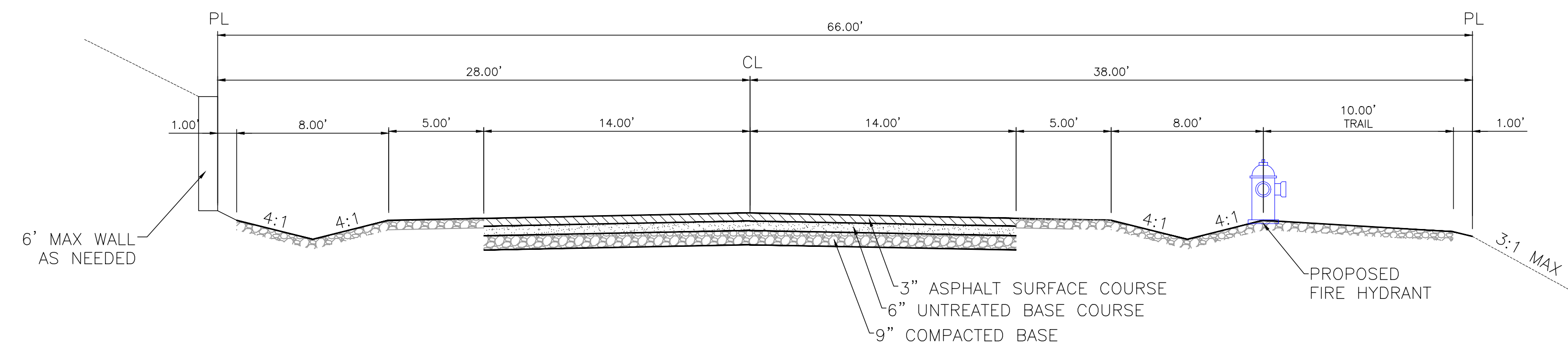

TYPICAL ROAD SECTION - 66 ROW TRAIL RT

NOT TO SCALE  
ROAD A  
WE WILL HOLD ROAD CL AND OFFSET ROW AS NEED FOR TRAIL ON LEFT OR RIGHT SIDE

## GENERAL GRADING NOTES

1. ALL WORK SHALL BE IN ACCORDANCE WITH THE LATEST APWA STANDARDS AND SPECIFICATION FOR PUBLIC WORKS AND THE COMPANY STANDARDS. CONTRACTOR SHALL ENSURE POSITIVE DRAINAGE AWAY FROM BUILDING FOUNDATIONS AND ENTRIES. FINISHED GRADE AT FOUNDATION FOR WOOD FRAMED STRUCTURES SHALL BE 8 INCHES BELOW TOP OF FOUNDATION AND DRAINAGE SHALL BE A MINIMUM OF 5% WITHIN 10 FEET FROM THE BUILDING.
2. MAXIMUM SLOPES SHALL BE 3:1 FOR CUT AND FILL UNLESS OTHERWISE NOTED.
3. COMPACTION REQUIREMENTS AND TESTING SHALL BE PERFORMED TO MEET THE MANUAL OF STD. SPECIFICATIONS (ORANGE BOOK, LATEST EDITION).
4. NO FILL SHALL BE PLACED UNTIL VEGETATION HAS BEEN REMOVED AND SUB-GRADE PREPARED PER THE SOILS REPORT.
5. DUST SHALL BE CONTROLLED BY WATERING OR OTHER APPROVED METHODS.
6. CONTRACTOR SHALL COMPLY WITH STORM WATER POLLUTION PREVENTION PLAN BY INSTALLING BMP'S PRIOR TO COMMENCEMENT OF EXCAVATION ACTIVITIES. CONTACT THE COUNTY INSPECTOR FOR INSPECTION.
7. ALL RECOMMENDATIONS OF THE GEOTECHNICAL REPORT (CG PROJECT NO. 133-014) AND ALL SUBSEQUENT REPORTS, ADDENDUM ETC. SHALL BE CONSIDERED A PART OF THE GRADING PLAN CONTAINED HEREIN AND SHALL BE COMPLIED WITH.
8. THE CONTRACTOR SHALL CONTACT BLUE STAKES FOR LOCATION MARKING PRIOR TO COMMENCING EXCAVATION ACTIVITIES.
9. COUNTY MAY REQUIRE A PRE-CONSTRUCTION MEETING BEFORE A PERMIT IS ISSUED.
10. STREETS ADJACENT TO THE PROJECT SHALL BE CLEAN AT ALL TIMES.
11. CONTRACTOR IS RESPONSIBLE FOR ARRANGING FOR ALL REQUIRED INSPECTIONS.
12. PRIOR TO TAKING WATER FROM A FIRE HYDRANT, THE CONTRACTOR SHALL MAKE ARRANGEMENTS WITH THE WATER UTILITY TO OBTAIN A WATER METER.

## SANITARY SEWER GENERAL NOTES

1. ALL SANITARY SEWER CONSTRUCTION SHALL BE IN CONFORMANCE WITH CITY STANDARDS AND SPECIFICATIONS.
2. ALL GRAVITY SANITARY SEWER LINES SHALL BE SDR-35 PVC MATERIAL. SEWER LINE CONSTRUCTION AND MATERIALS SHALL CONFORM TO ASTM STANDARDS AND SPECIFICATIONS.
3. DISTANCES SHOWN ON PLANS ARE APPROXIMATE AND COULD VARY DUE TO VERTICAL ALIGNMENT.
4. RIM ELEVATIONS SHOWN ARE APPROXIMATE ONLY AND ARE NOT TO BE TAKEN AS FINAL ELEVATION. PIPELINE CONTRACTOR SHALL USE PRECAST CONCRETE ADJUSTMENT RINGS, GROUT AND STEEL SHIMS TO ADJUST THE MANHOLE FRAME TO THE REQUIRED FINAL GRADE IN CONFORMANCE WITH THE STANDARD SPECIFICATIONS. ALL FRAMES SHALL BE ADJUSTED TO FINAL GRADE.
5. ALL SANITARY SEWER MAIN TESTING SHALL BE IN ACCORDANCE WITH THE CITY STANDARDS AND SPECIFICATIONS. COPIES OF ALL TEST RESULTS SHALL BE PROVIDED TO THE PUBLIC WORKS SANITARY SEWER DEPARTMENT HEAD PRIOR TO FINAL ACCEPTANCE.
6. COMPACTION TESTING OF ALL TRENCHES WITH THE PROJECT SITE MUST BE ATTAINED AND RESULTS SUBMITTED TO THE CITY ENGINEER PRIOR TO FINAL ACCEPTANCE.
7. CONTRACTOR IS RESPONSIBLE TO PROTECT ALL EXISTING STRUCTURES AND IMPROVEMENTS DURING INSTALLATION OF SANITARY SEWER LINE.
8. WHERE CONNECTION TO EXISTING UTILITY IS PROPOSED, CONTRACTOR SHALL VERIFY LOCATION AND ELEVATION AND NOTIFY OWNER/ENGINEER IF LOCATION AND ELEVATION OF EXISTING UTILITY VARIES FROM THE DESIGN.
9. CAMERA TESTING AND PRESSURE TESTING PER CITY STANDARD.

TYPICAL SECTIONS AND GENERAL NOTES

OSPREY RANCH

UT-158

EDEN, WEBER, UTAH

**GARDNER**  
**ENGINEERING**  
CIVIL • LAND PLANNING  
MUNICIPAL • LAND SURVEYING  
5150 SOUTH 375 EAST OGDEN, UT  
OFFICE: 801-476-0202 FAX: 801-476-0066

TS1

# SITE PLAN - PHASE 1 OSPREY RANCH

- COMMON AREA - 32.16 ACRES
- PHASE LINE
- ROADSIDE PATHWAY
- SOFT TRAIL
- PROPOSED BOUNDARY

BUILDING AREAS SHOWN ARE INTENDED TO ONLY SHOW NUMBER OF PROPOSED UNITS AND THE APPROXIMATE LOCATIONS. LOCATION AND SIZE ARE SUBJECT TO CHANGE BASED ON LOT OWNERS DESIGNS.

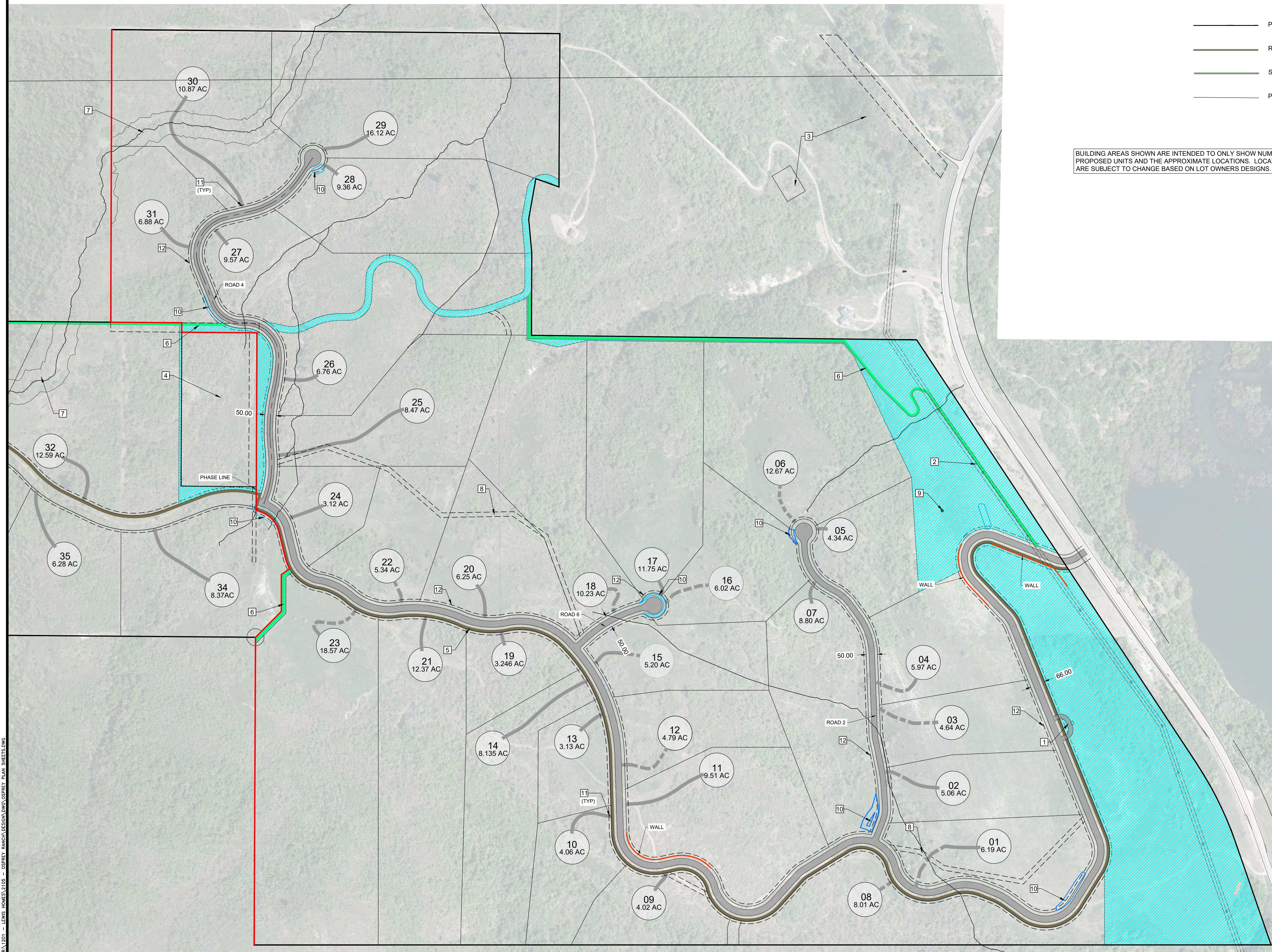

- KEY NOTES:**
- 1 MAIL PICKUP AREA (BY OTHERS)
  - 2 POWER CORRIDOR
  - 3 SEWER TREATMENT AREA (BY OTHERS)
  - 4 FRANKLIN AND BETH MAUGHAN - 5 ACRES
  - 5 ROAD SIDE PATHWAY (SEE TS1 TYPICAL SECTIONS) (7225 FT)
  - 6 SOFT TRAIL (3618 FT)
  - 7 50 FT - EPHEMERAL STREAM SETBACK
  - 8 20 FT - SEWER EASEMENT
  - 9 MONUMENT SIGN
  - 10 DETENTION POND
  - 11 PROPOSED DRIVEWAY LOCATION
  - 12 10' PUE

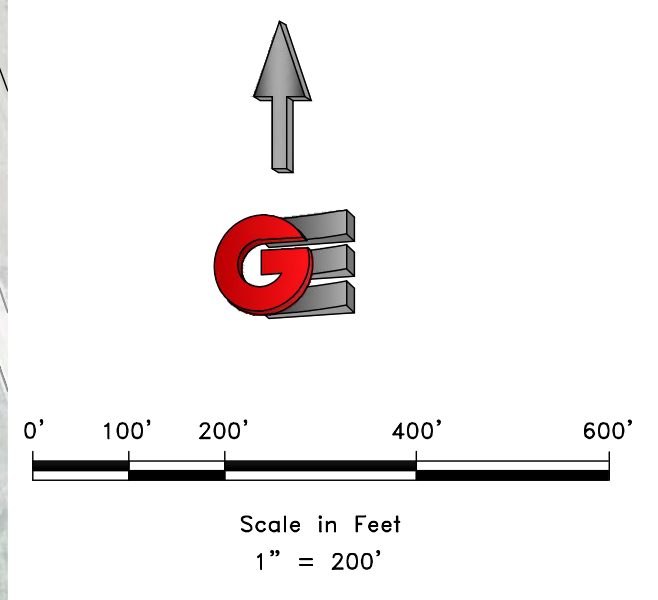

REVISIONS	DESCRIPTION
DATE	

SCALE	1" = 200'
DATE	06-06-22
DESIGN	KAN
DRAWN	KAN
CHECKED	RC

SITE PLAN - PHASE 1  
OSPREY RANCH  
UT-158  
EDEN, WEBER, UTAH

**GARDNER ENGINEERING**

CIVIL • LAND PLANNING  
MUNICIPAL • LAND SURVEYING

51150 SOUTH 375 EAST OGDEN, UT  
OFFICE: 801-476-0202 FAX: 801-476-0066

SP1

DWG: 1201 - LEWIS, HOMES 2105 - OSPREY RANCH, UTAH, OSPREY PLAN SHEETS.DWG

# OVERALL UTILITY PLAN OSPREY RANCH

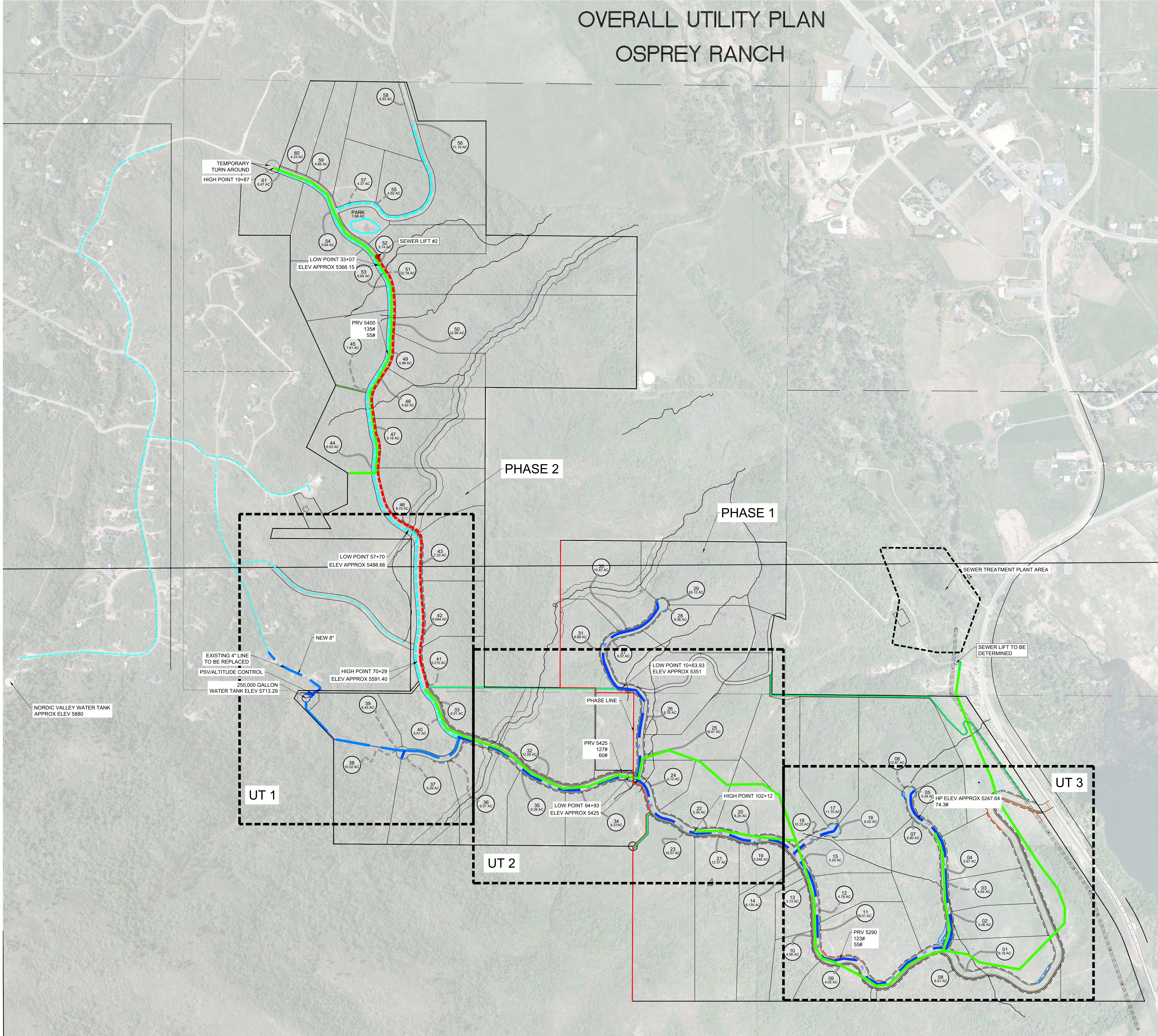

- - - - - PRESSURE SEWER
- - - - - GRAVITY SEWER
- - - - - LOW PRESSURE SEWER
- - - - - PROPOSED 12" WATERLINE
- - - - - PROPOSED 8" WATERLINE
- - - - - EXISTING WATERLINE
  
- 250,000 GALLON WATER TANK
- ◀ PROPOSED FIRE HYDRANT
- ⊠ PROPOSED PRV
- PROPOSED SEWER LIFT STATION

- SEWER IMPROVEMENTS**
- PHASE 1**
- GRAVITY SEWER
  - LOW PRESSURE SEWER
  - SEWER TREATMENT PLANT
- PHASE 2**
- LOW PRESSURE SEWER
  - 1 SEWER LIFT STATION WITH HIGH PRESSURE SEWER

- CULINARY WATER IMPROVEMENTS**
- PHASE 1**
- 250 K GALLON WATER TANK
  - 12"/8" WATER MAIN
  - PRESSURE SUSTAINING/ALTITUDE VALVE STATION
  - 2 - PRESSURE REDUCING VALVES
- PHASE 2**
- 8" WATER MAIN
  - 1 - PRESSURE REDUCING VALVE

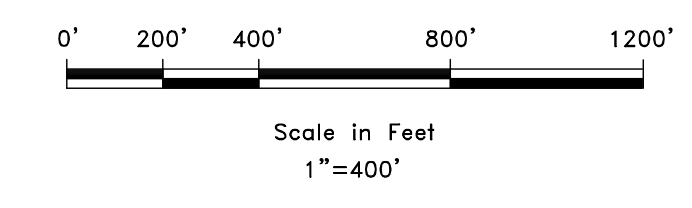
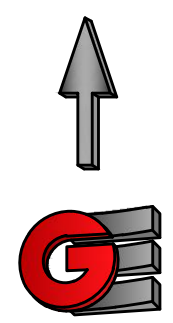

REVISIONS	DESCRIPTION
DATE	

SCALE	1"=400'
DATE	06-06-22
DESIGN	KAN
DRAWN	KAN
CHECKED	RC

OVERALL UTILITY PLAN  
OSPREY RANCH  
UT-158  
EDEN, WEBER, UTAH

**GARDNER ENGINEERING**  
CIVIL • LAND PLANNING  
MUNICIPAL • LAND SURVEYING  
51150 SOUTH 375 EAST OGDEN, UT  
OFFICE: 801-476-0202 FAX: 801-476-0066

UM1

A:\1201 - LEWIS, HOMES\1205 - OSPREY RANCH\DESIGN\DWG\OSPREY PLAN SHEETS.DWG



# UTILITY PLAN PHASE 1 OSPREY RANCH

- PROPOSED WATER
- PROPOSED PRESSURE SEWER
- PROPOSED LOW PRESSURE SEWER
- PROPOSED GRAVITY SEWER
- PROPOSED STORM DRAIN/CULVERT
- PROPOSED DRAINAGE DITCH

- PROPOSED FIRE HYDRANT
- ⊠ PROPOSED PRV
- TRAIL

### KEY NOTES

- ① 8" WATER C900 DR18 (MIN DEPTH 5')
- ② FIRE HYDRANT (SEE DT4)
- ③ GATE VALVES (SEE DT4)
- ④ 8" SEWER - SDR 35 PVC
- ⑤ 2" LOW PRESSURE SEWER - SDR11 HDPE (MIN DEPTH 5')
- ⑥ LOW PRESSURE LATERAL SEE DETAIL DT5
- ⑦ GRAVITY SEWER LATERAL
- ⑧ WATER SERVICE LATERAL (SEE DT 4)
- ⑨ LOW PRESSURE SEWER CLEANOUT
- ⑩ POND OUTLET SEE DT6
- ⑪ 15" RCP STORM DRAIN

Osprey Sewer STRUCTURE TABLE			
STRUCTURE NAME:	DETAILS:	PIPES IN:	PIPES OUT
SSMH10 4' SSMH	RIM = 5431.93 INV IN = 5423.46 INV OUT = 5423.36	INV (W)=5423.46	INV (E)=5423.36
SSMH11 4' SSMH	RIM = 5425.93 INV IN = 5417.76 INV OUT = 5417.66	INV (W)=5417.76	INV (N)=5417.66
SSMH12 8' SSMH	RIM = 5416.85 INV IN = 5406.45 INV OUT = 5406.35	INV (S)=5406.45	INV (E)=5406.35
SSMH13 4' SSMH	RIM = 5415.00 INV IN = 5405.38 INV OUT = 5405.28	INV (W)=5405.38	INV (E)=5405.28
SSMH14 4' SSMH	RIM = 5412.57 INV IN = 5404.12 INV OUT = 5404.02	INV (W)=5404.12	INV (SE)=5404.02
SSMH15 4' SSMH	RIM = 5410.00 INV IN = 5402.18 INV OUT = 5402.08	INV (NW)=5402.18	INV (E)=5402.08
SSMH16 4' SSMH	RIM = 5408.13 INV IN = 5400.81 INV OUT = 5400.71	INV (W)=5400.81	INV (SE)=5400.71
SSMH17 4' SSMH	RIM = 5407.96 INV IN = 5400.02 INV OUT = 5399.92	INV (NW)=5400.02	INV (S)=5399.92
SSMH42 4' SSMH	RIM = 5438.22 INV IN = 5428.50 INV OUT = 5428.40	INV (W)=5428.50	INV (E)=5428.40
SSMH43 4' SSMH	RIM = 5458.26 INV IN = 5450.26 INV OUT = 5450.16	INV (W)=5450.26	INV (E)=5450.16
SSMH44 4' SSMH	RIM = 5470.74 INV OUT = 5464.89		INV (E)=5464.89

- LOW PRESSURE SEWER PUMP
- PUMP TO GRAVITY SEWER

REVISIONS	
DATE	DESCRIPTION
6/7/22	REVISED SERVICE LATERAL LOCATIONS

SCALE	DATE	DESIGN	DRAWN	CHECKED
1" = 100'	6/7/22	KAN	KAN	PC

UTILITY PLAN PHASE 1  
OSPREY RANCH  
1800 N HYW 158  
EDEN, WEBER, UTAH

**GARDNER ENGINEERING**  
CIVIL-LAND PLANNING  
MUNICIPAL-LAND SURVEYING  
5150 SOUTH 375 EAST OGDEN, UT  
OFFICE: 801.476.0202 FAX: 801.476.0066

UT2

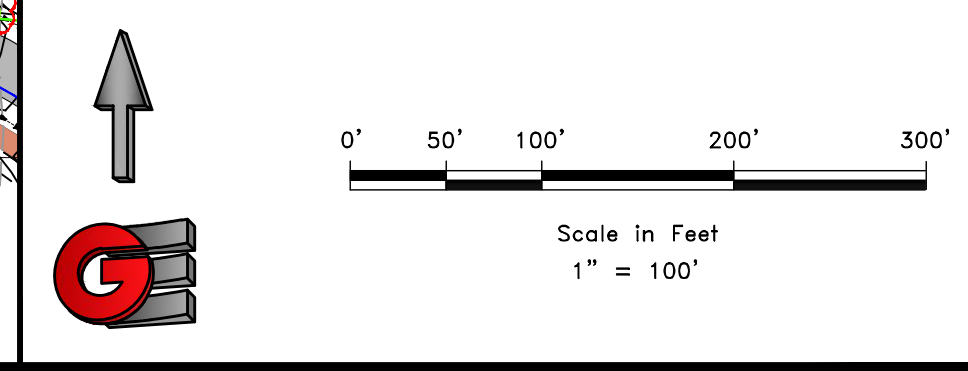
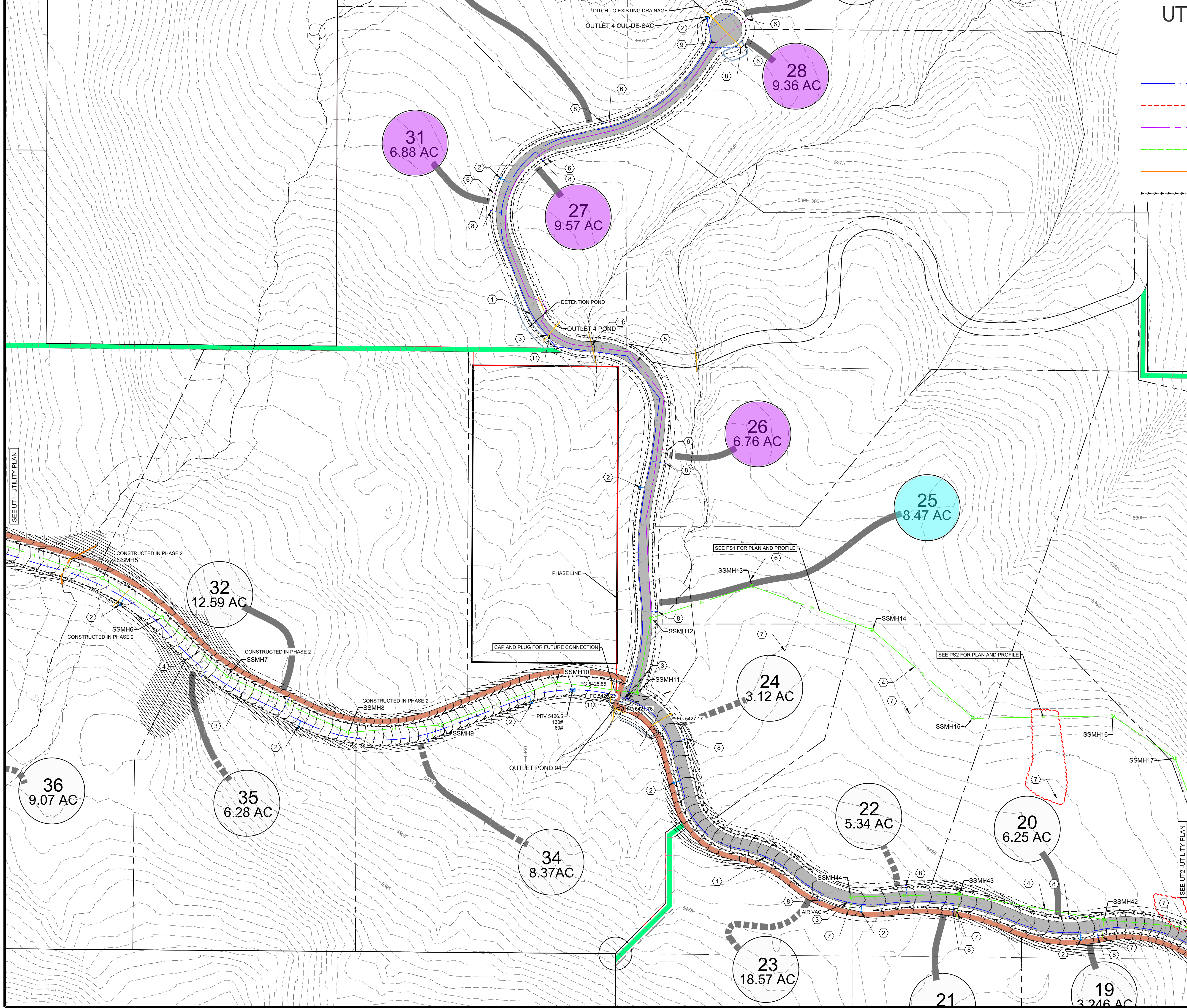



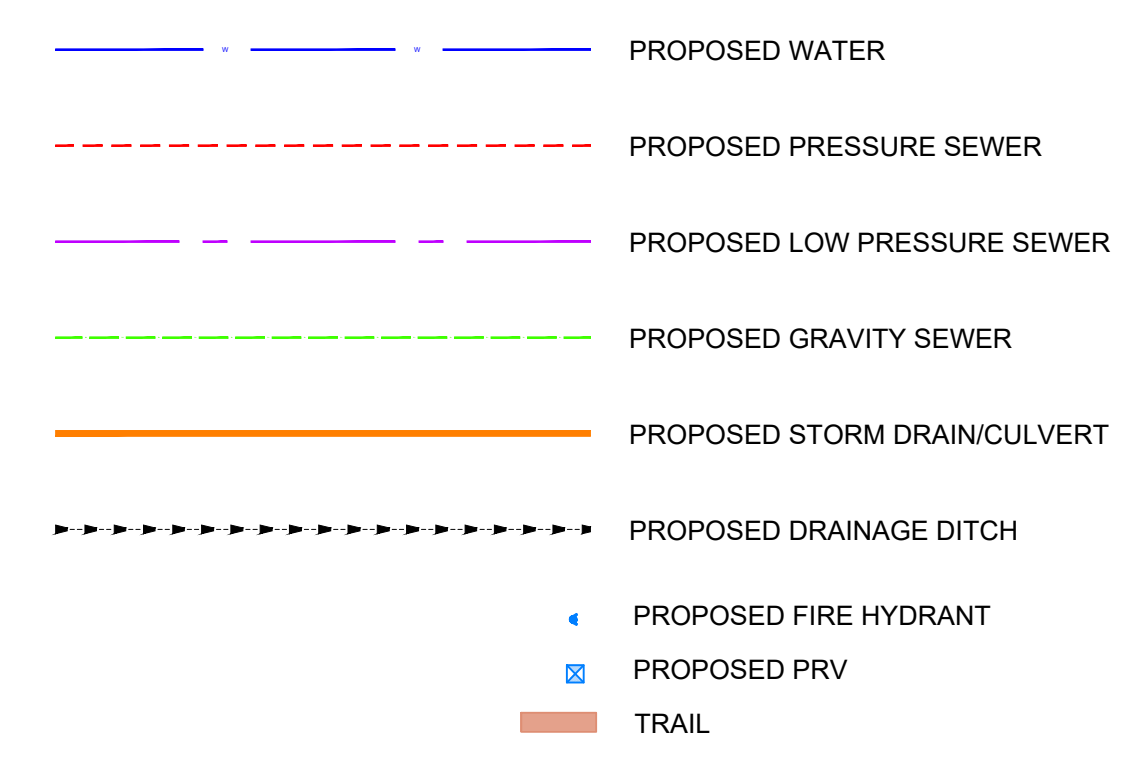
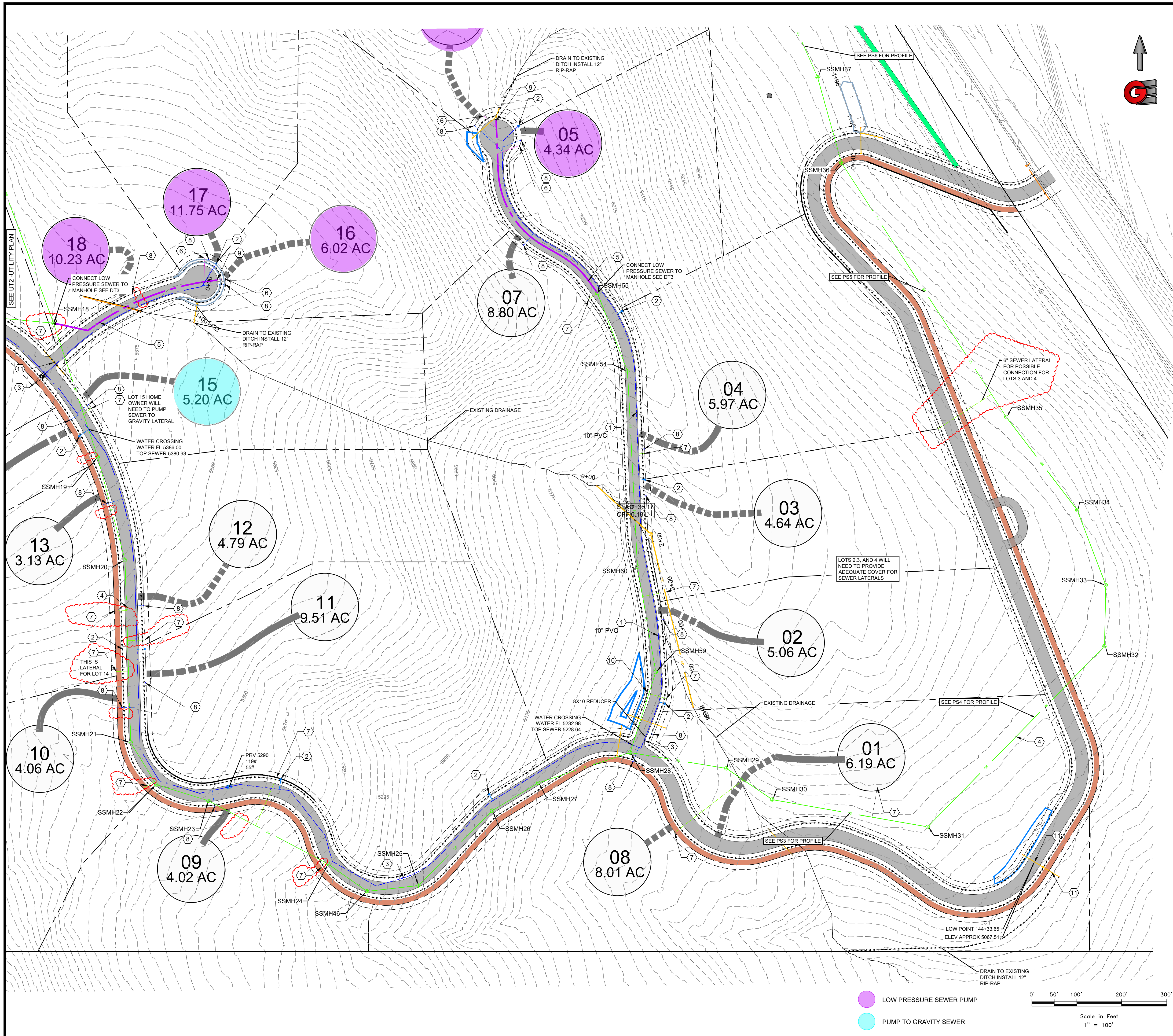

**KEY NOTES**

- ① 8" WATER C900 DR18 UNLESS INDICATED OTHERWISE (MIN DEPTH 5')
- ② FIRE HYDRANT (SEE DT4)
- ③ GATE VALVES (SEE DT4)
- ④ 8" SEWER - SDR 35 PVC
- ⑤ 2" LOW PRESSURE SEWER - SDR11 HDPE (MIN DEPTH 5')
- ⑥ LOW PRESSURE LATERAL SEE DETAIL DT5
- ⑦ GRAVITY SEWER LATERAL
- ⑧ WATER SERVICE LATERAL (SEE DT4)
- ⑨ LOW PRESSURE SEWER CLEANOUT
- ⑩ POND OUTLET SEE DT6
- ⑪ 15" RCP STORM DRAIN

**Osprey Sewer STRUCTURE TABLE**

STRUCTURE NAME:	DETAILS:	PIPES IN:	PIPES OUT:
SSMH18 5' SSMH	RIM = 5404.40 INV IN = 5397.82 INV IN (W) = 5397.82 INV OUT = 5397.72	INV (N) = 5397.82 INV (W) = 5397.82	INV (S) = 5397.72
SSMH19 4' SSMH	RIM = 5381.65 INV IN = 5373.33 INV OUT = 5373.23	INV (N) = 5373.33	INV (S) = 5373.23
SSMH20 4' SSMH	RIM = 5352.73 INV IN = 5346.68 INV OUT = 5346.58	INV (N) = 5346.68	INV (S) = 5346.58
SSMH21 4' SSMH	RIM = 5304.15 INV IN = 5297.77 INV OUT = 5297.67	INV (N) = 5297.77	INV (SE) = 5297.67
SSMH22 4' SSMH	RIM = 5291.75 INV IN = 5285.59 INV OUT = 5285.49	INV (NW) = 5285.59 INV (E) = 5285.49	
SSMH23 4' SSMH	RIM = 5277.91 INV IN = 5269.91 INV OUT = 5269.81	INV (W) = 5269.91 INV (SE) = 5269.81	
SSMH24 4' SSMH	RIM = 5234.23 INV IN = 5225.78 INV OUT = 5225.68	INV (NW) = 5225.78 INV (SE) = 5225.68	
SSMH25 4' SSMH	RIM = 5209.16 INV IN = 5202.12 INV OUT = 5202.02	INV (W) = 5202.12 INV (NE) = 5202.02	
SSMH26 4' SSMH	RIM = 5181.45 INV IN = 5174.38 INV OUT = 5174.28	INV (SW) = 5174.38 INV (NE) = 5174.28	
SSMH27 4' SSMH	RIM = 5166.86 INV IN = 5159.87 INV OUT = 5159.77	INV (SW) = 5159.87 INV (E) = 5159.77	
SSMH28 5' SSMH	RIM = 5138.97 INV IN = 5129.55 INV IN (N) = 5129.55 INV OUT = 5129.45	INV (W) = 5129.55 INV (E) = 5129.45	
SSMH29 4' SSMH	RIM = 5102.12 INV IN = 5092.02 INV OUT = 5091.92	INV (W) = 5092.02 INV (SE) = 5091.92	
SSMH30 4' SSMH	RIM = 5097.87 INV IN = 5091.28 INV OUT = 5091.39	INV (NW) = 5091.28 INV (E) = 5091.39	
SSMH31 4' SSMH	RIM = 5095.00 INV IN = 5090.06 INV OUT = 5089.96	INV (W) = 5090.06 INV (NE) = 5089.96	
SSMH32 4' SSMH	RIM = 5095.00 INV IN = 5087.82 INV OUT = 5087.72	INV (SW) = 5087.82 INV (N) = 5087.72	
SSMH33 4' SSMH	RIM = 5095.00 INV IN = 5087.20 INV OUT = 5087.10	INV (S) = 5087.20 INV (N) = 5087.10	
SSMH34 4' SSMH	RIM = 5095.00 INV IN = 5086.42 INV OUT = 5086.32	INV (S) = 5086.42 INV (NW) = 5086.32	
SSMH35 4' SSMH	RIM = 5095.03 INV IN = 5085.33 INV OUT = 5085.23	INV (SE) = 5085.33 INV (NW) = 5085.23	
SSMH36 4' SSMH	RIM = 5051.27 INV IN = 5044.56 INV OUT = 5044.46	INV (SE) = 5044.56 INV (N) = 5044.46	
SSMH37 4' SSMH	RIM = 5050.81 INV IN = 5040.38 INV OUT = 5040.28	INV (S) = 5040.38 INV (NW) = 5040.28	
SSMH46 4' SSMH	RIM = 5222.31 INV IN = 5215.24 INV OUT = 5215.14	INV (NW) = 5215.24 INV (E) = 5215.14	
SSMH54 4' SSMH	RIM = 5207.71 INV IN = 5199.53 INV OUT = 5199.43	INV (N) = 5199.53 INV (S) = 5199.43	
SSMH55 4' SSMH	RIM = 5230.83 INV OUT = 5224.65	INV (S) = 5224.65	
SSMH59 4' SSMH	RIM = 5138.93 INV IN = 5130.40 INV OUT = 5130.30	INV (N) = 5130.40 INV (S) = 5130.30	
SSMH60 4' SSMH	RIM = 5155.54 INV IN = 5147.58 INV OUT = 5147.48	INV (N) = 5147.58 INV (S) = 5147.48	

SCALE: 1" = 100'

DATE: 6/7/22

DESIGN: KAN

DRAWN: KAN

CHECKED: PC

REVISIONS

DATE	DESCRIPTION
6/7/22	REVISED SEWER LATERAL LOCATIONS

DMG: R.V.201 - LEWIS HOMES, 2105 - OSPREY RANCH, DESIGN/OWN/OSPREY UTILITY PLAN.DWG

UTILITY PLAN PHASE 1

OSPREY RANCH

1800 N HYW 158

EDEN, WEBER, UTAH

**GARDNER ENGINEERING**

CIVIL-LAND PLANNING  
MUNICIPAL-LAND SURVEYING

5150 SOUTH 375 EAST OGDEN, UT  
OFFICE: 801-476-0202 FAX: 801-476-0066

UT3

# PHASE 1 - DRAINAGE OSPREY RANCH

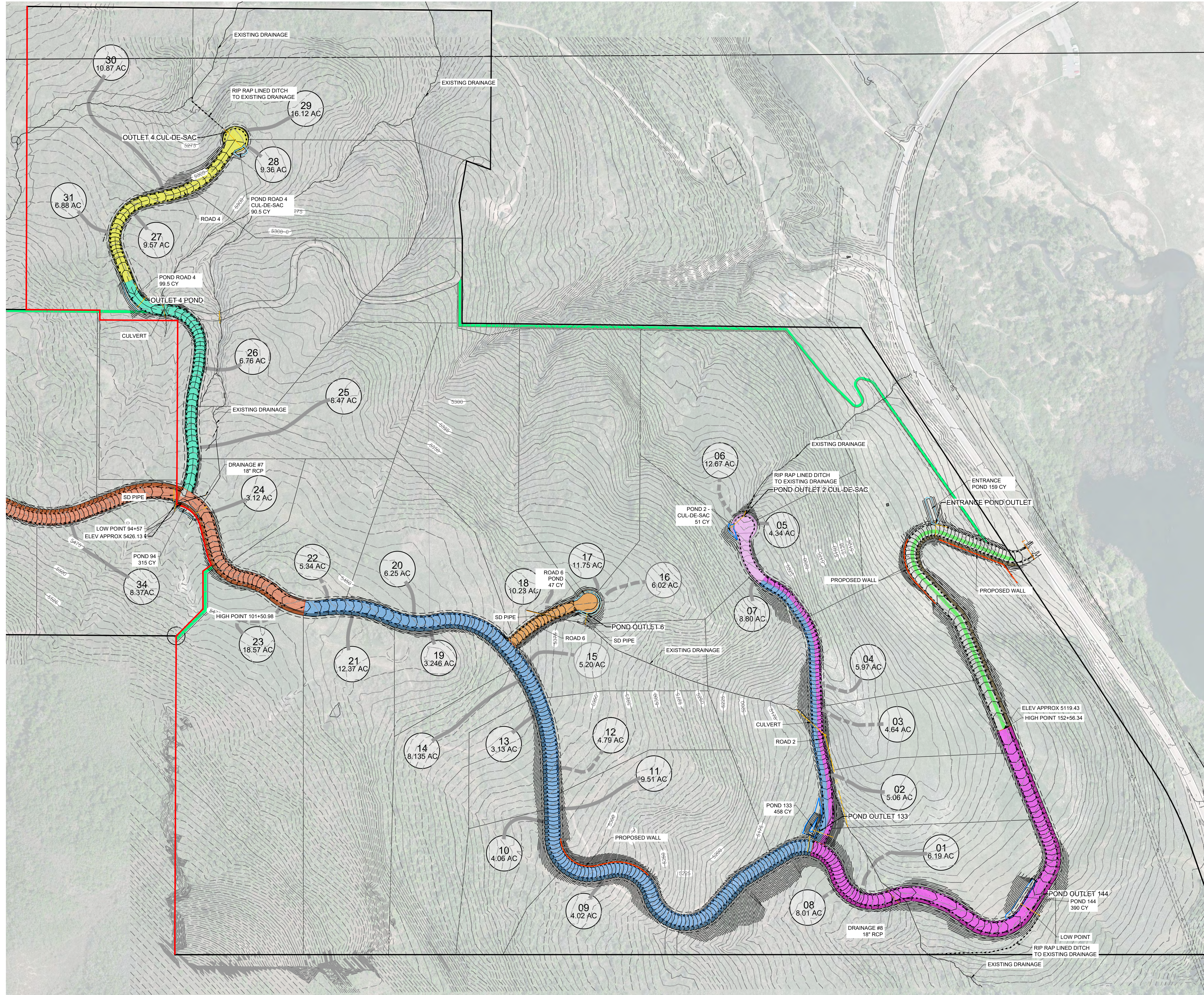

Basin	Area (acres)	Detention Volume (cf)
Pond 94	3.67	315
Pond 133	6.17	520
Pond 144	2.91	244
Pond Road 4	1.23	94
Pond 4 cul-de-sac	1.19	91
Pond 2 cul-de-sac	0.44	34
Entrance Pond	2.06	158
Road 6	0.59	45

- NOTE:
1. DETENTION CALCS ARE FOR THE 10 YR STORM WITH A RELEASE RATE OF 0.1 CFS/SCRE
  2. ALL LOTS ARE REQUIRED TO PROVIDE THEIR OWN DETENTION TO CONTROL RUNOFF.
  3. STORM WATER RUN OFF FROM ROAD RIGHT OF WAY TO BE DETAINED BY PROJECT IMPROVEMENTS.
  4. SEE DR4 AND DR5 FOR PROFILE OF POND OUTLETS

--- EXISTING DRAINAGE DITCH  
 --- PROPOSED STORM DRAIN

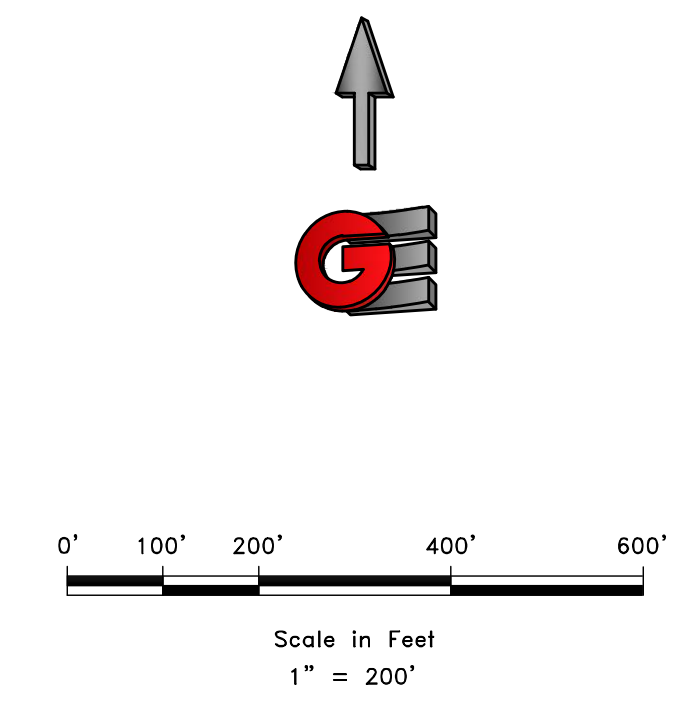

REVISIONS	DESCRIPTION
DATE	

PHASE 1 - DRAINAGE  
OSPREY RANCH  
UT-158  
EDEN, WEBER, UTAH

**GARDNER ENGINEERING**  
 CIVIL • LAND PLANNING  
 MUNICIPAL • LAND SURVEYING  
 51150 SOUTH 375 EAST OGDEN, UT  
 OFFICE: 801-476-0202 FAX: 801-476-0066

DR1

A:\1201 - LEWIS, HOWARD, 2105 - OSPREY RANCH\LEWIS\DWG\OSPREY PLAN SHEETS.DWG

SCALE: 1" = 200'  
 DATE: 06-06-22  
 DESIGN: KAN  
 DRAWN: KAN  
 CHECKED: RC

# PHASE 1 - BASIN CALCULATIONS OSPREY RANCH

SCALE	DATE	DESIGN	DRAWN	CHECKED
	6-22-21	KAN	KAN	RC
REVISIONS				
DATE	DESCRIPTION			

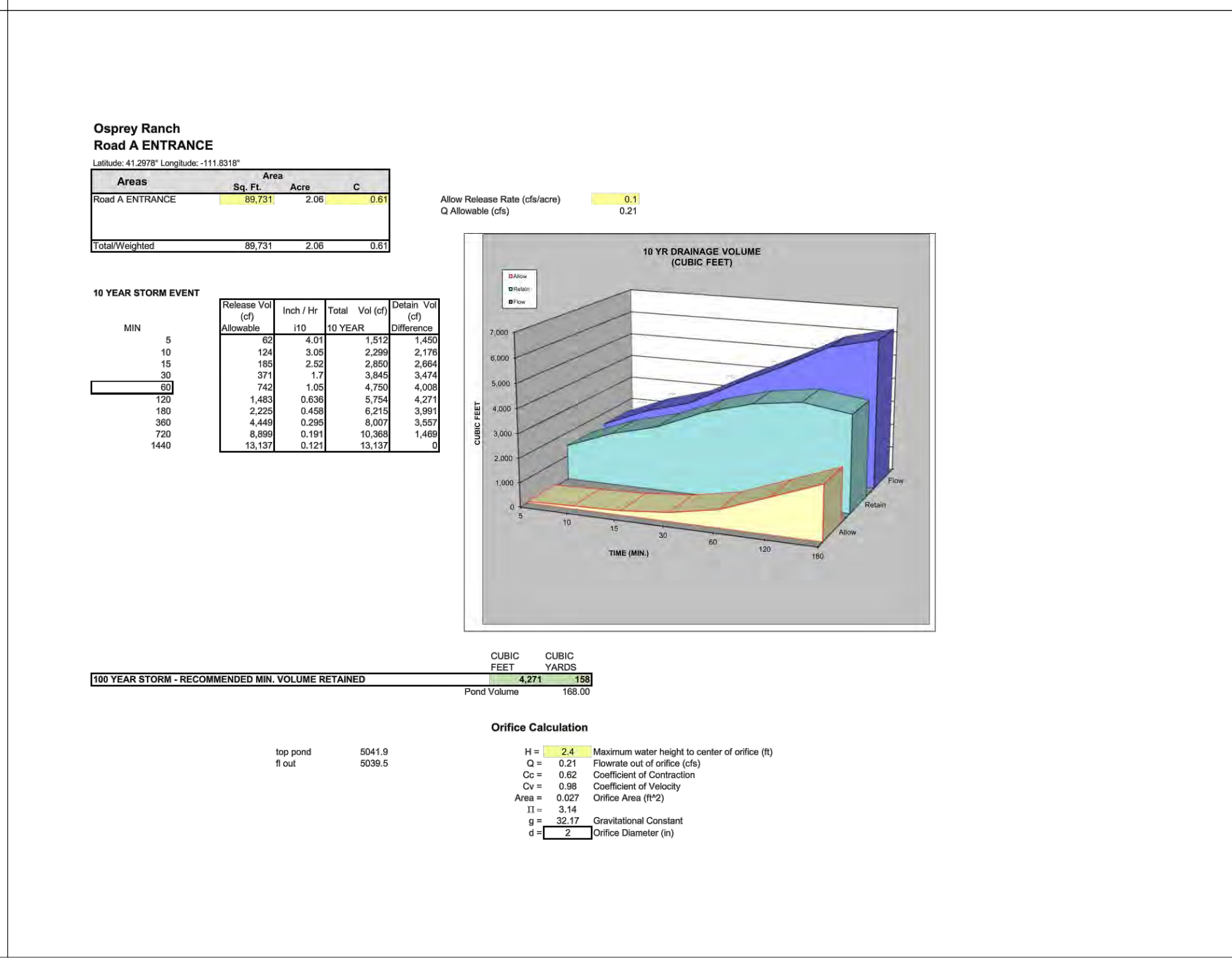
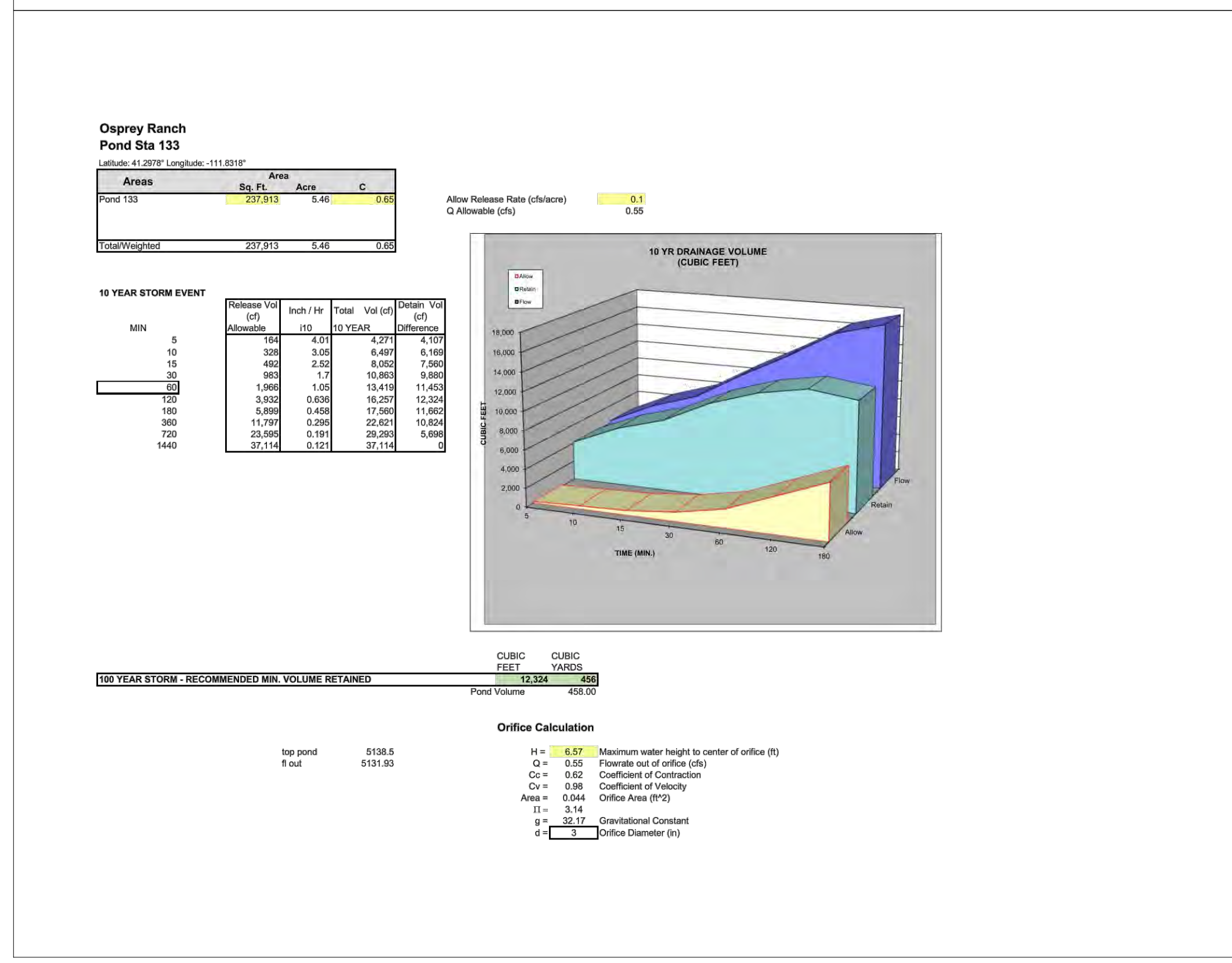
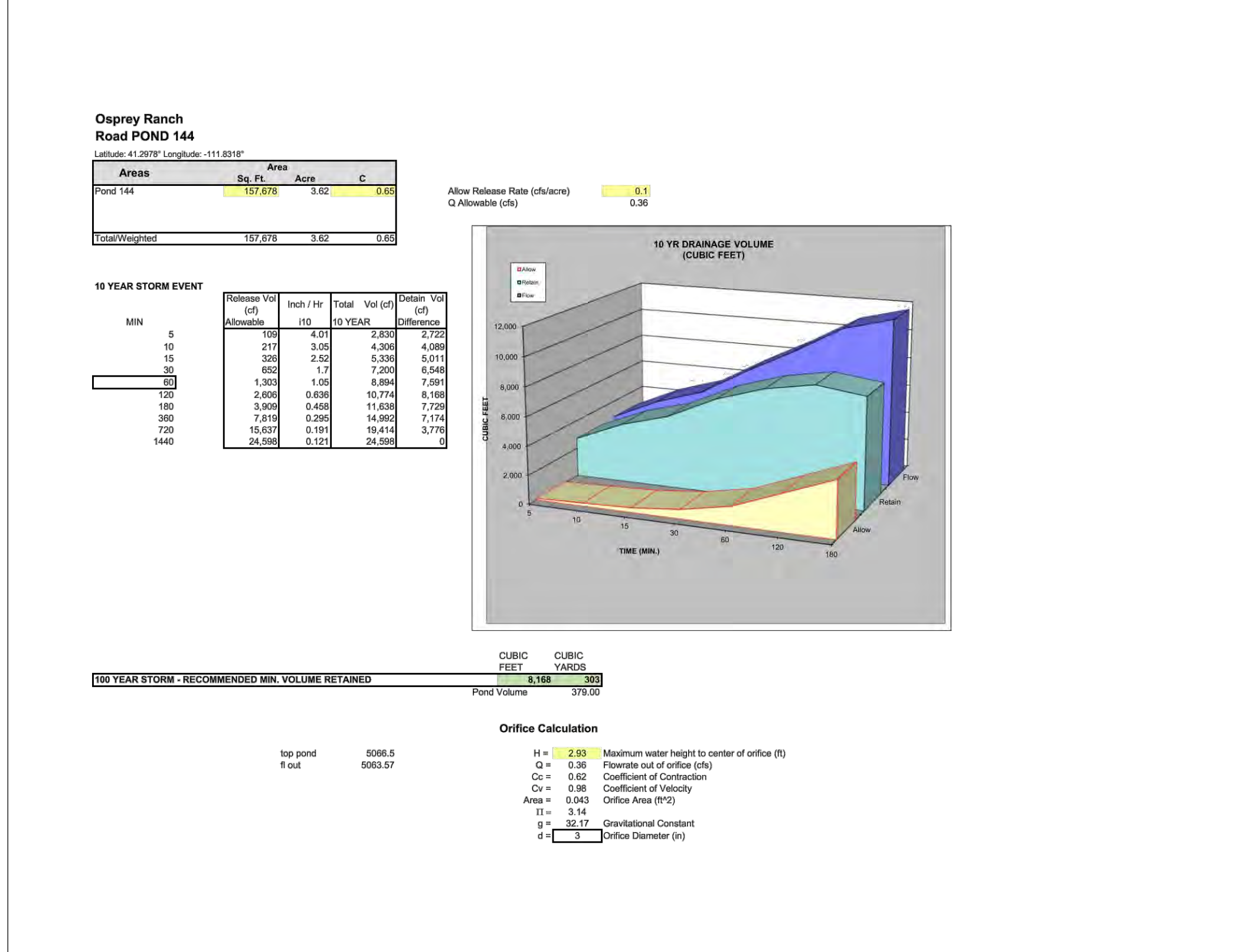
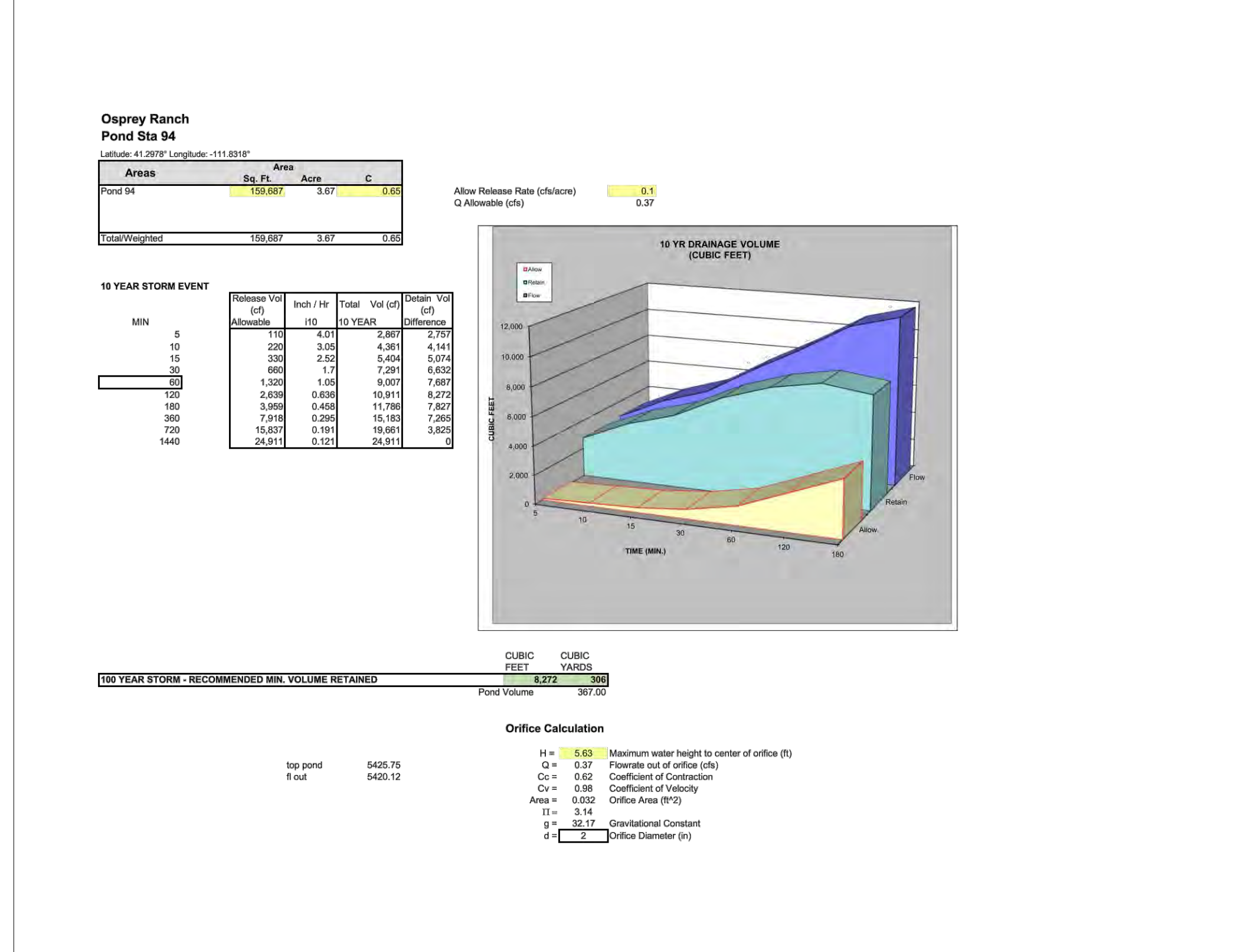

PHASE 1 - BASIN CALCULATIONS  
OSPREY RANCH  
UT-158  
EDEN, WEBER, UTAH

**GARDNER ENGINEERING**  
 CIVIL • LAND PLANNING  
 MUNICIPAL • LAND SURVEYING  
 51150 SOUTH 375 EAST OGDEN, UT  
 OFFICE: 801.476.0202 FAX: 801.476.0066

R:\1201 - LEWIS HOMES\2105 - OSPREY RANCH DESIGN\DWG\OSPREY PLAN SHEETS.DWG

# PHASE 1 - BASIN CALCULATIONS OSPREY RANCH

SCALE: 6-22-21  
DATE: 6-22-21  
DESIGN: KAN  
DRAWN: KAN  
CHECKED: RC

REVISIONS	DESCRIPTION
DATE	

DWG.

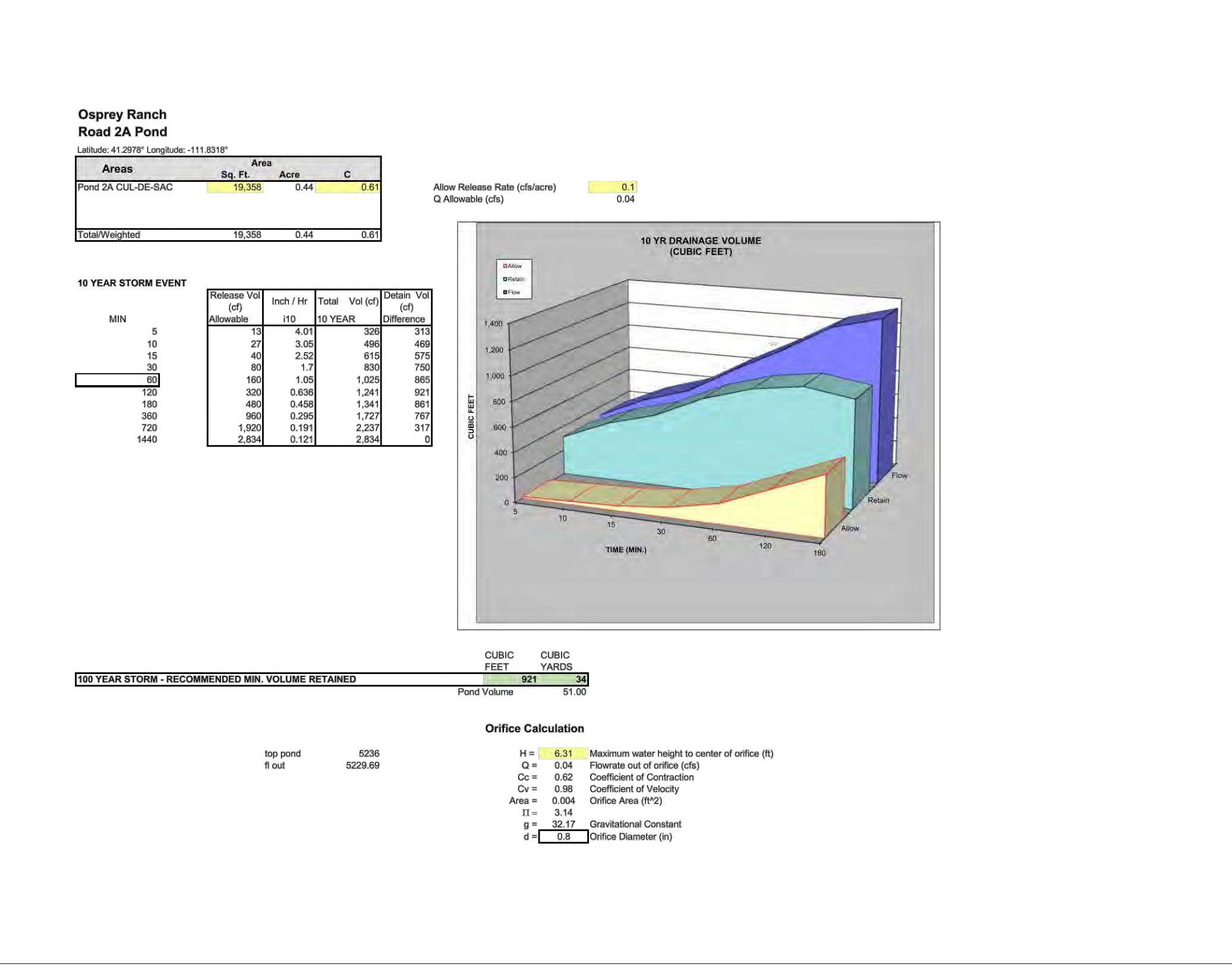
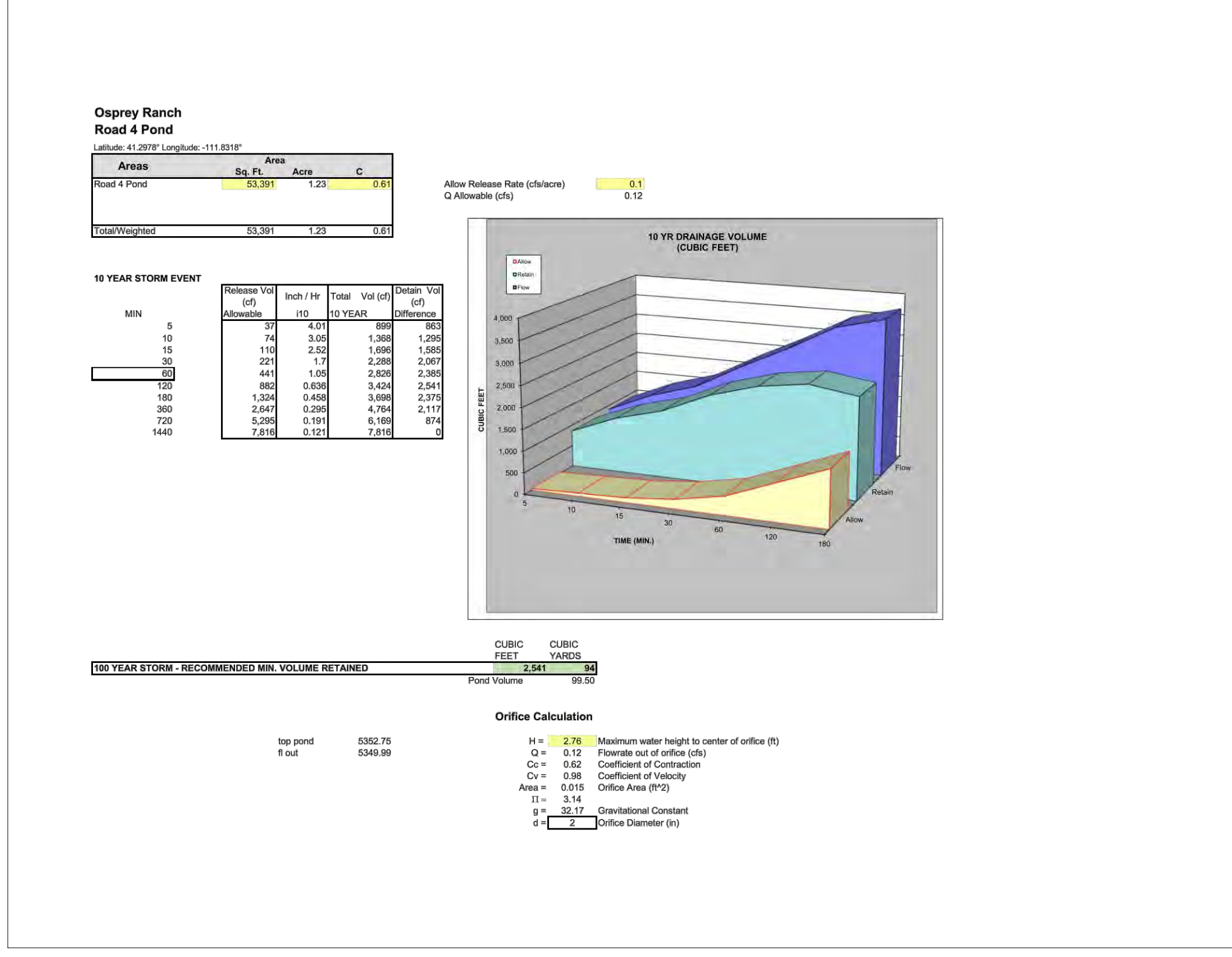
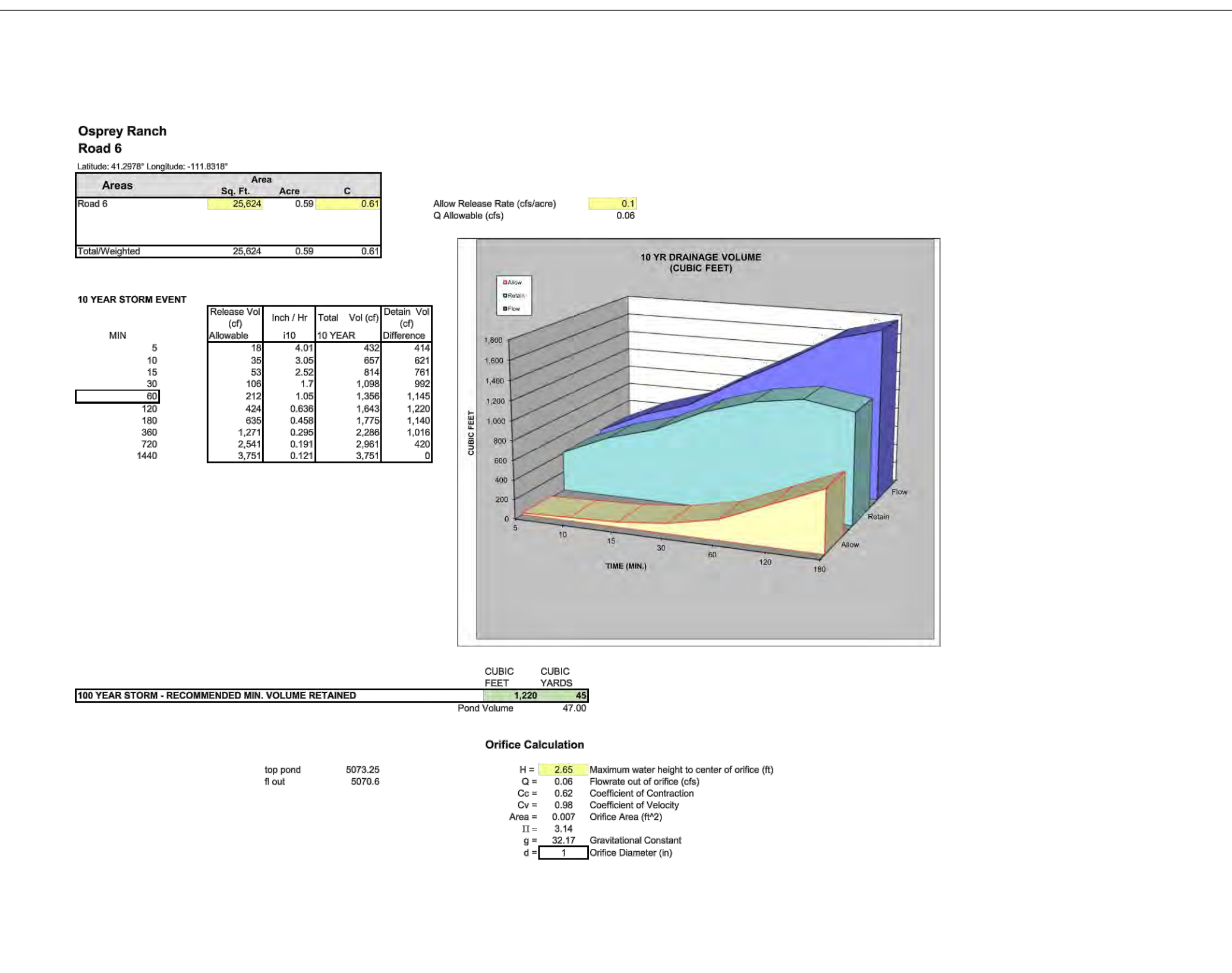
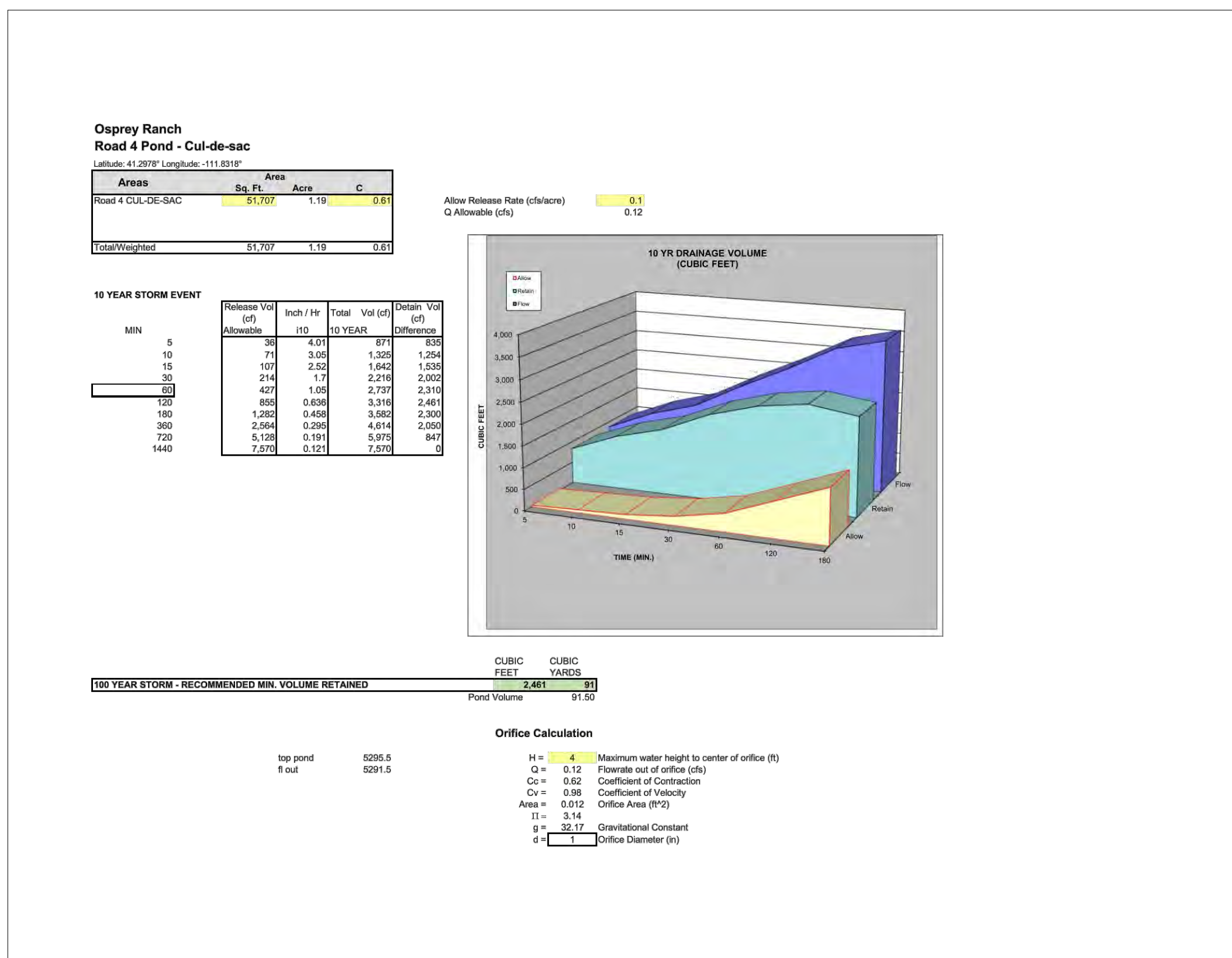

PHASE 1 - BASIN CALCULATIONS  
 OSPREY RANCH  
 UT-158  
 EDEN, WEBER, UTAH

**GARDNER ENGINEERING**  
 CIVIL • LAND PLANNING  
 MUNICIPAL • LAND SURVEYING  
 51150 SOUTH 375 EAST OGDEN, UT  
 OFFICE: 801.476.0202 FAX: 801.476.0066

R:\1201 - LEWIS HOMES\1205 - OSPREY RANCH DESIGN\DWG\OSPREY PLAN SHEETS.DWG

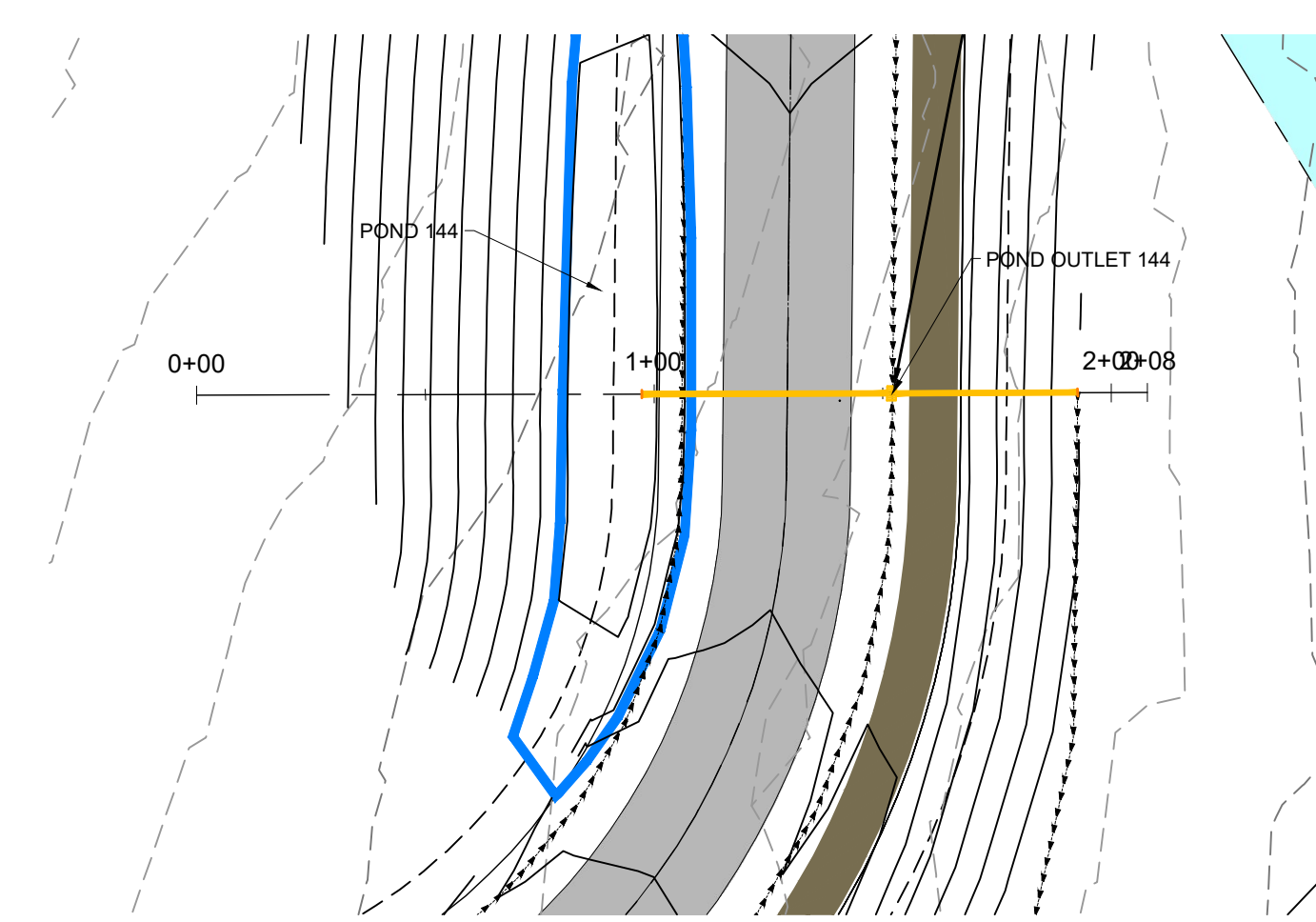
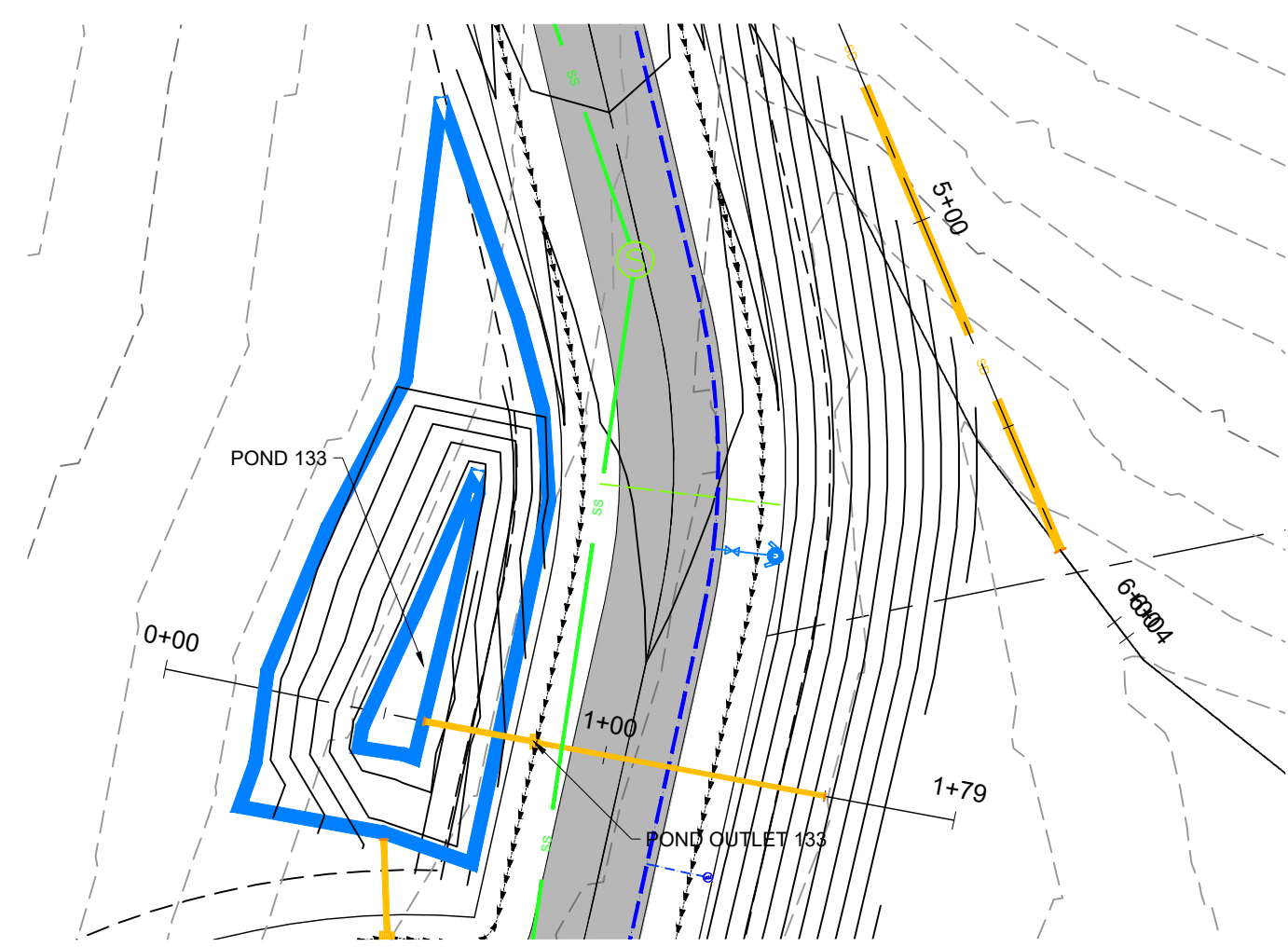
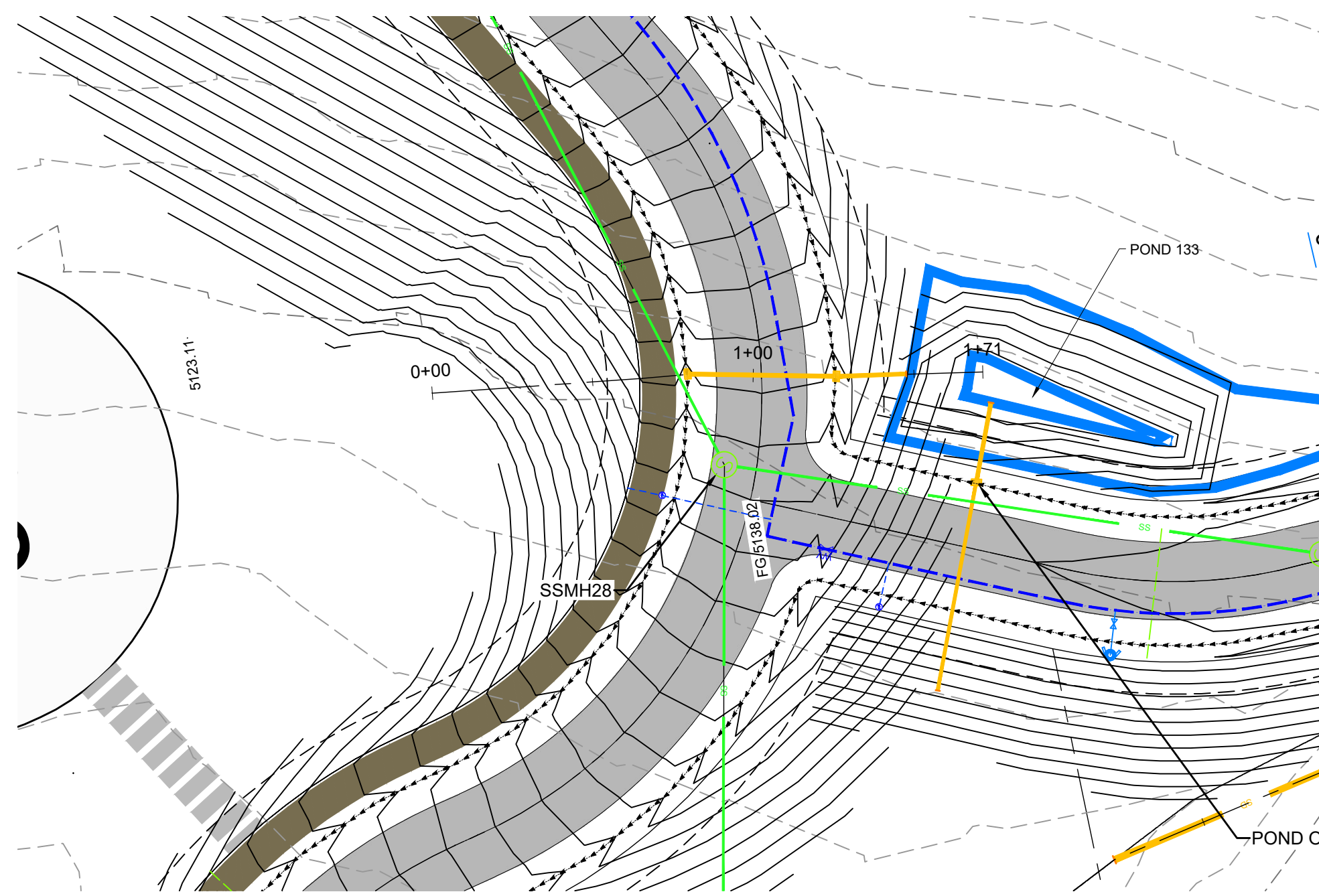
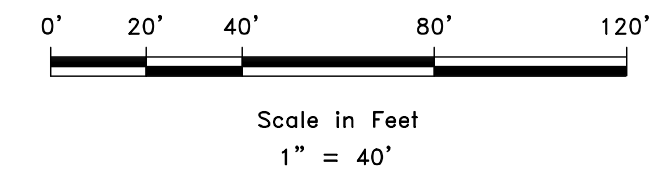

pipe crossing 133

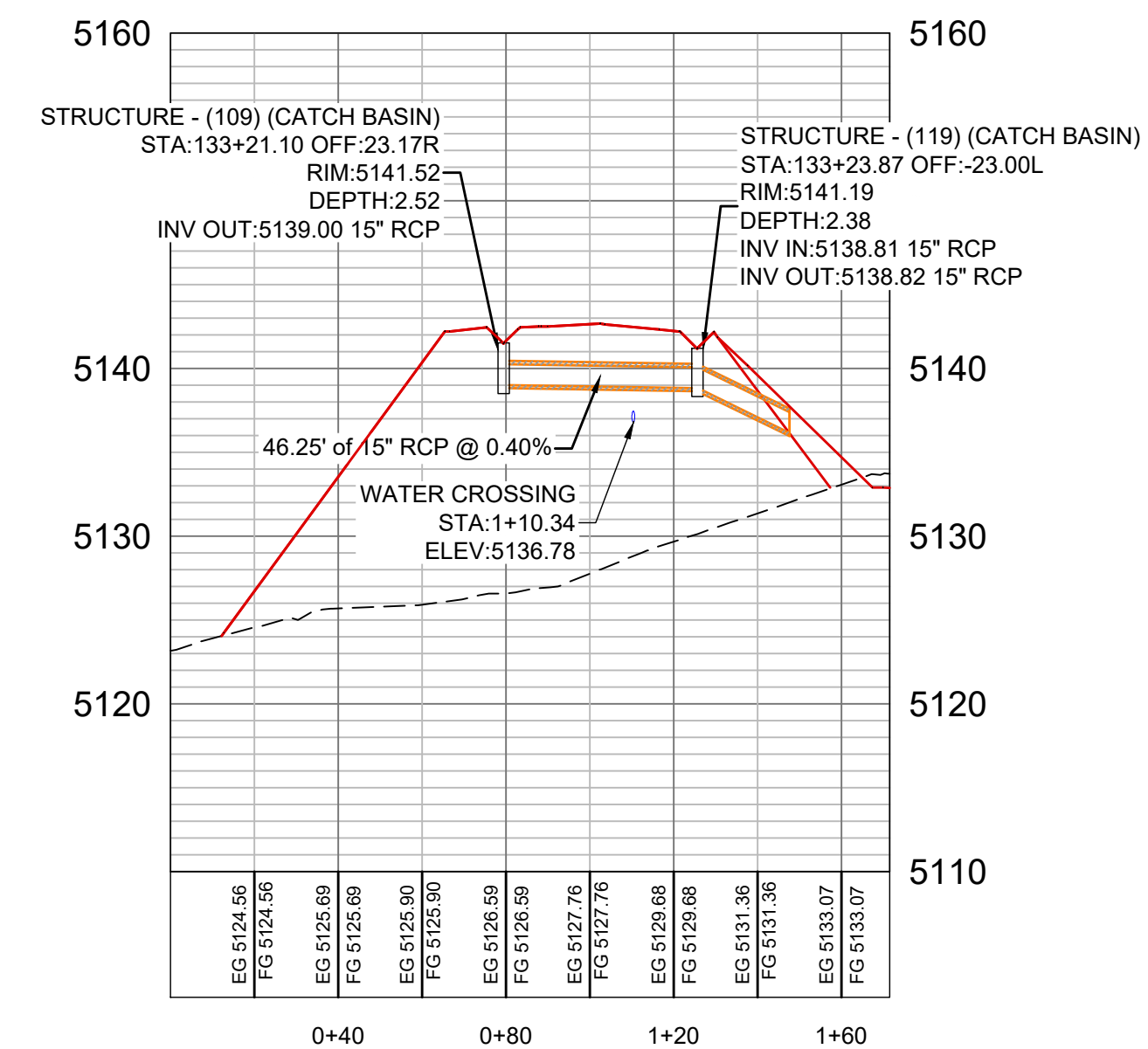

pond outlet

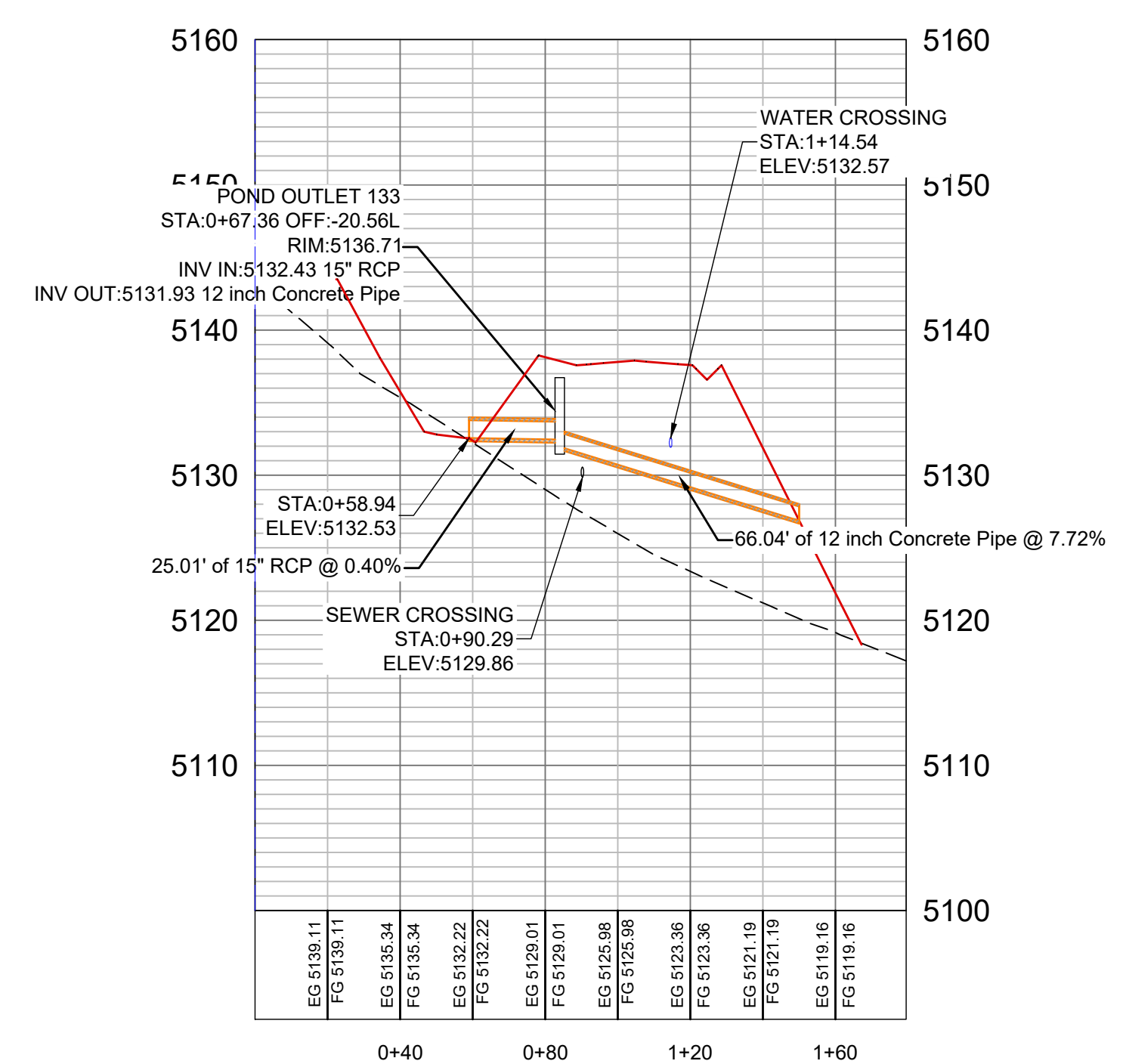

storm drain CROSSING 144

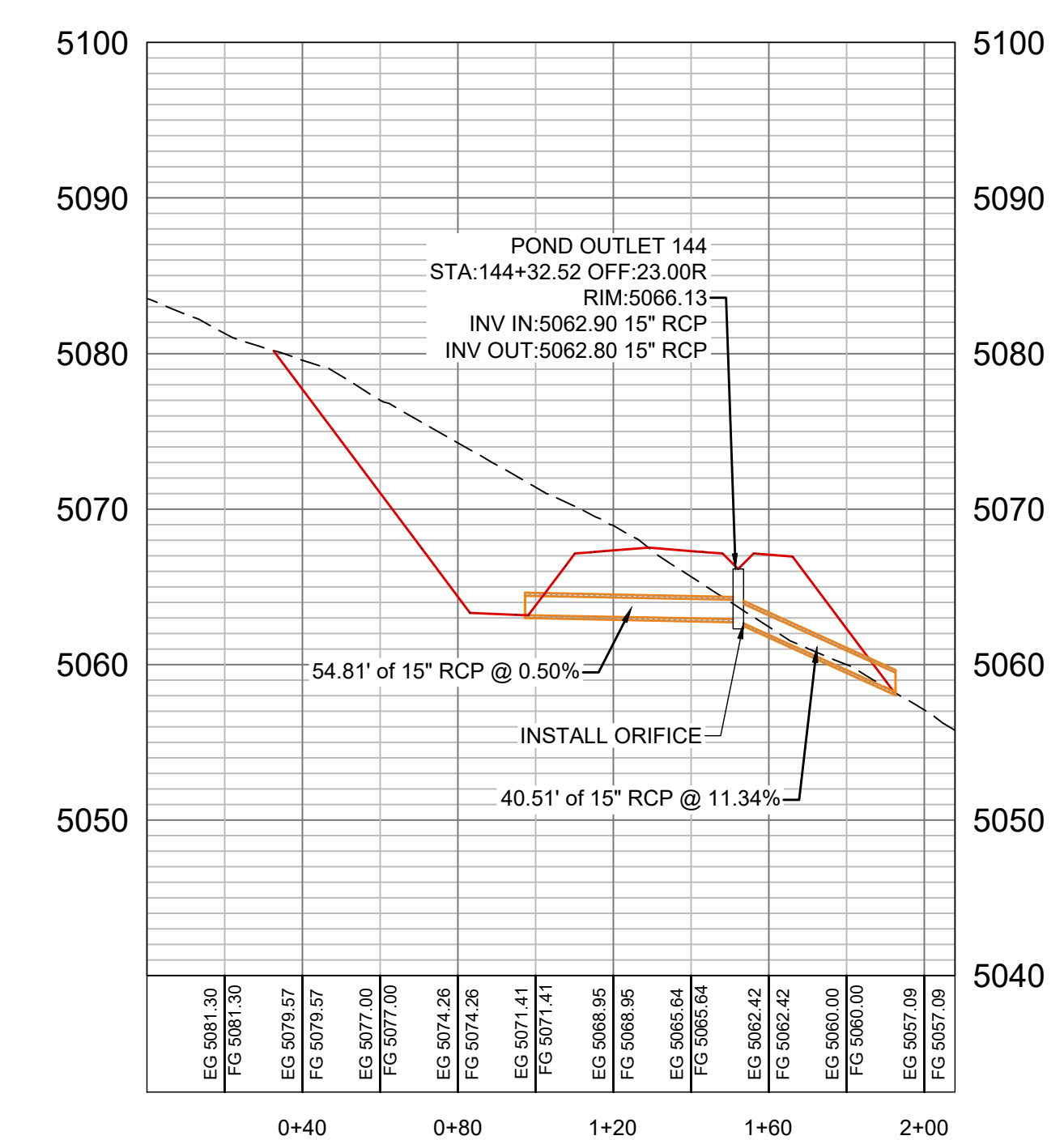

SCALE	1" = 40'
DATE	5-10-22
DESIGN	KAN
DRAWN	KAN
CHECKED	RC

REVISIONS	DESCRIPTION
DATE	

DWG:	
------	--

SD CROSSINGS  
 OSPREY RANCH  
 UT-158  
 EDEN, WEBER, UTAH

**GARDNER ENGINEERING**  
 CIVIL • LAND PLANNING  
 MUNICIPAL • LAND SURVEYING  
 5150 SOUTH 375 EAST OGDEN, UT  
 OFFICE: 801.476.0202 FAX: 801.476.0066

AN 1201 - LEWIS, HOMES 2105 - OSPREY RANCH, UTAH, OSPREY PLAN PROFILE SHEETS PHASE 1 - RECORD RECOVERING



# STORM WATER PROTECTION PLAN

## OSPREY RANCH

TOTAL AREA 629.64 ACRES  
TOTAL DISTURBED AREA 32.61 ACRES

### EROSION CONTROL NOTES:

1. SANDBAGS WILL BE PLACED AT DISCHARGE LOCATIONS TO CONTAIN AND DIVERT STORM WATER THROUGH THE INLET PROTECTION.
2. AN EARTHEN BERM 6" HIGH WILL BE CONSTRUCTED TO CONTAIN THE STORM WATER AND DIVERT IT TO DISCHARGE AREAS.
3. STORM WATER WILL BE DISCHARGED INTO AN EXISTING DRAINAGE SYSTEM. EXISTING LINES SHALL BE INSPECTED PRIOR TO CERTIFICATE OF OCCUPANCY AND CLEANED IF NECESSARY.
4. THE STORM WATER POLLUTION PREVENTION PLAN SHALL CONFORM TO ALL STATE DIVISION OF ENVIRONMENTAL PROTECTION REGULATIONS.

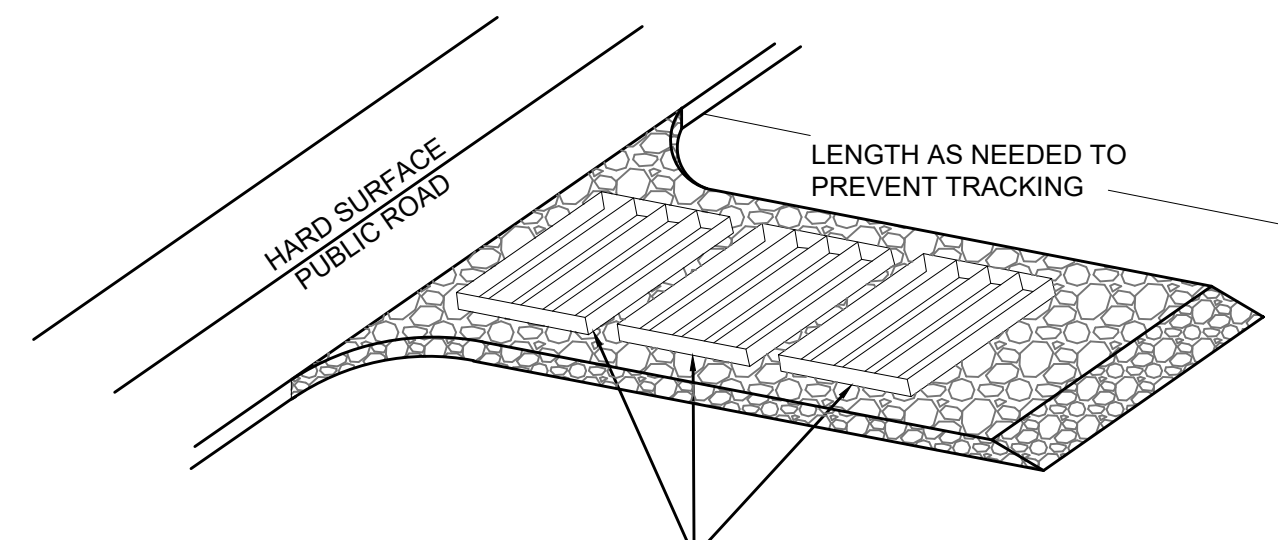

A SERIES OF STEEL PLATES (3 OR MORE) WITH RUMBLE STRIPS OR MIN. 3" COARSE AGGREGATE.

### ENTRANCE STABILIZATION NOTES:

1. SEDIMENTS AND OTHER MATERIALS SHALL NOT BE TRACKED FROM THE SITE BY VEHICLE TRAFFIC. THE CONSTRUCTION ENTRANCE ROADWAYS SHALL BE STABILIZED SO AS TO PREVENT SEDIMENTS FROM BEING DEPOSITED INTO THE STORM DRAIN SYSTEMS. DEPOSITIONS MUST BE SWEEPED UP IMMEDIATELY AND MAY NOT BE WASHED DOWN BY RAIN OR OTHER MEANS INTO THE STORM DRAIN SYSTEM.
2. STABILIZED CONSTRUCTION ENTRANCE SHALL BE:
  - a. LOCATED AT ANY POINT WHERE TRAFFIC WILL BE ENTERING OR LEAVING A CONSTRUCTION SITE TO OR FROM A PUBLIC RIGHT-OF-WAY, STREET, ALLEY AND SIDEWALK OR PARKING AREA.
  - b. A SERIES OF STEEL PLATES WITH "RUMBLE STRIPS", AND/OR MIN. 3" COARSE AGGREGATE WITH LENGTH, WIDTH AND THICKNESS AS NEEDED TO ADEQUATELY PREVENT ANY TRACKING ONTO PAVED SURFACES.
3. ADDING A WASH RACK WITH A SEDIMENT TRAP LARGE ENOUGH TO COLLECT ALL WASH WATER CAN GREATLY IMPROVE EFFICIENCY.
4. ALL VEHICLES ACCESSING THE CONSTRUCTION SITE SHALL UTILIZE THE STABILIZED CONSTRUCTION ENTRANCE SITES.

### STREET MAINTENANCE NOTES:

1. REMOVE ALL SEDIMENT DEPOSITED ON PAVED ROADWAYS IMMEDIATELY.
2. SWEEP PAVED AREAS THAT RECEIVE CONSTRUCTION TRAFFIC WHENEVER SEDIMENT BECOMES VISIBLE.
3. PAVEMENT WASHING WITH WATER IS PROHIBITED IF IT RESULTS IN A DISCHARGE TO THE STORM DRAIN SYSTEM.

### NOTE:

CONTRACTOR SHALL COMPLETE AND SUBMIT A STATE NOTICE OF INTENT (NOI) AND A STORM WATER POLLUTION PREVENTION PLAN BOOKLET

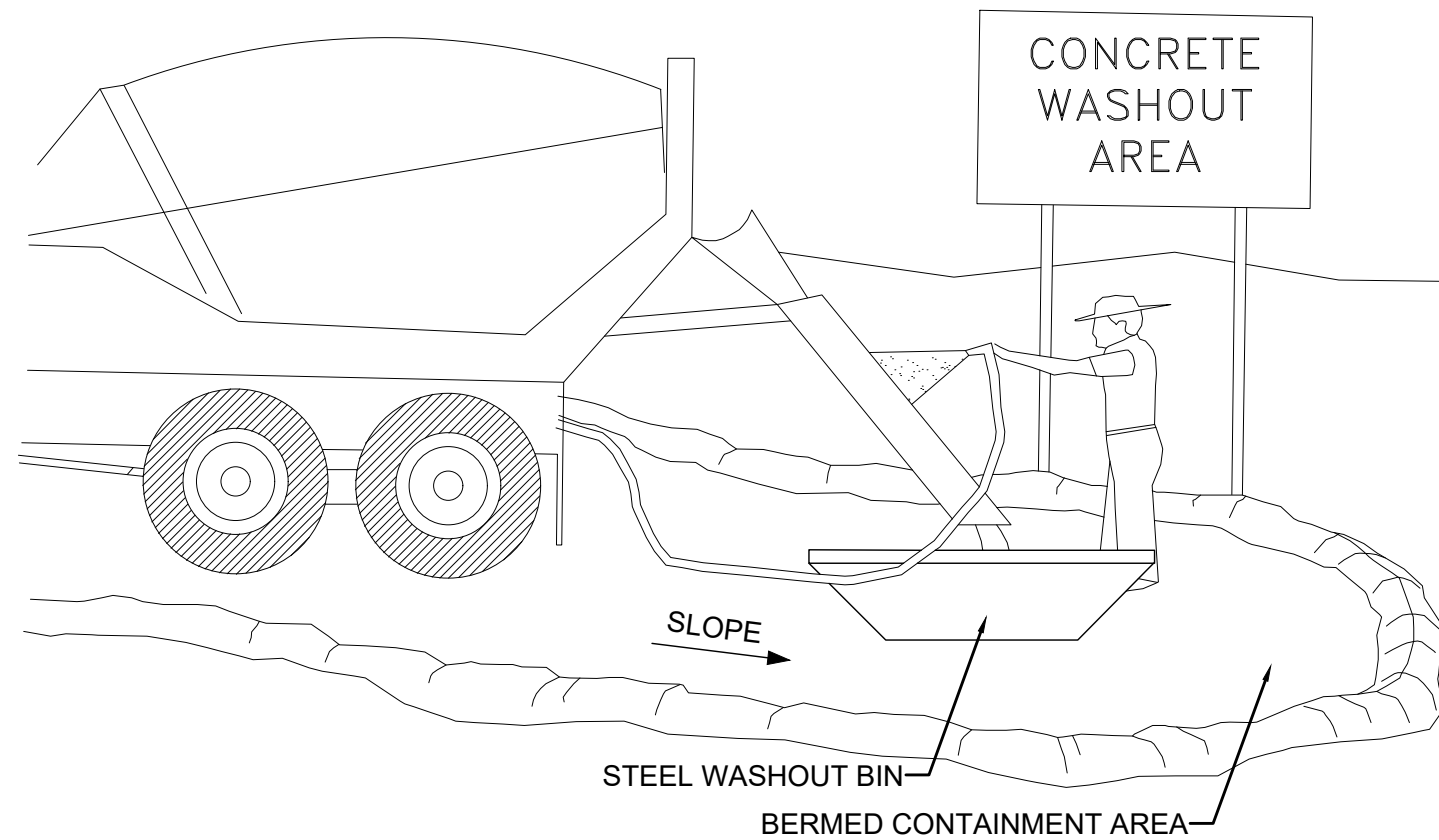

### NOTES:

1. EXCESS AND WASTE CONCRETE SHALL BE DISPOSED OF OFF SITE OR AT DESIGNATED AREAS ONLY.
2. EXCESS AND WASTE CONCRETE SHALL NOT BE WASHED INTO THE STREET OR INTO A DRAINAGE SYSTEM.
3. FOR WASHOUT OF CONCRETE AND MORTAR PRODUCTS ONSITE, A DESIGNATED CONTAINMENT FACILITY OF SUFFICIENT CAPACITY TO RETAIN LIQUID AND SOLID WASTE SHALL BE PROVIDED.
4. ONSITE CONCRETE WASHOUT CONTAINMENT FACILITY SHALL BE A STEEL BIN OR APPROVED ALTERNATE.
5. SLURRY FROM CONCRETE AND ASPHALT SAW CUTTING SHALL BE VACUUMED OR CONTAINED, DRIED, PICKED UP AND DISPOSED OF PROPERLY.

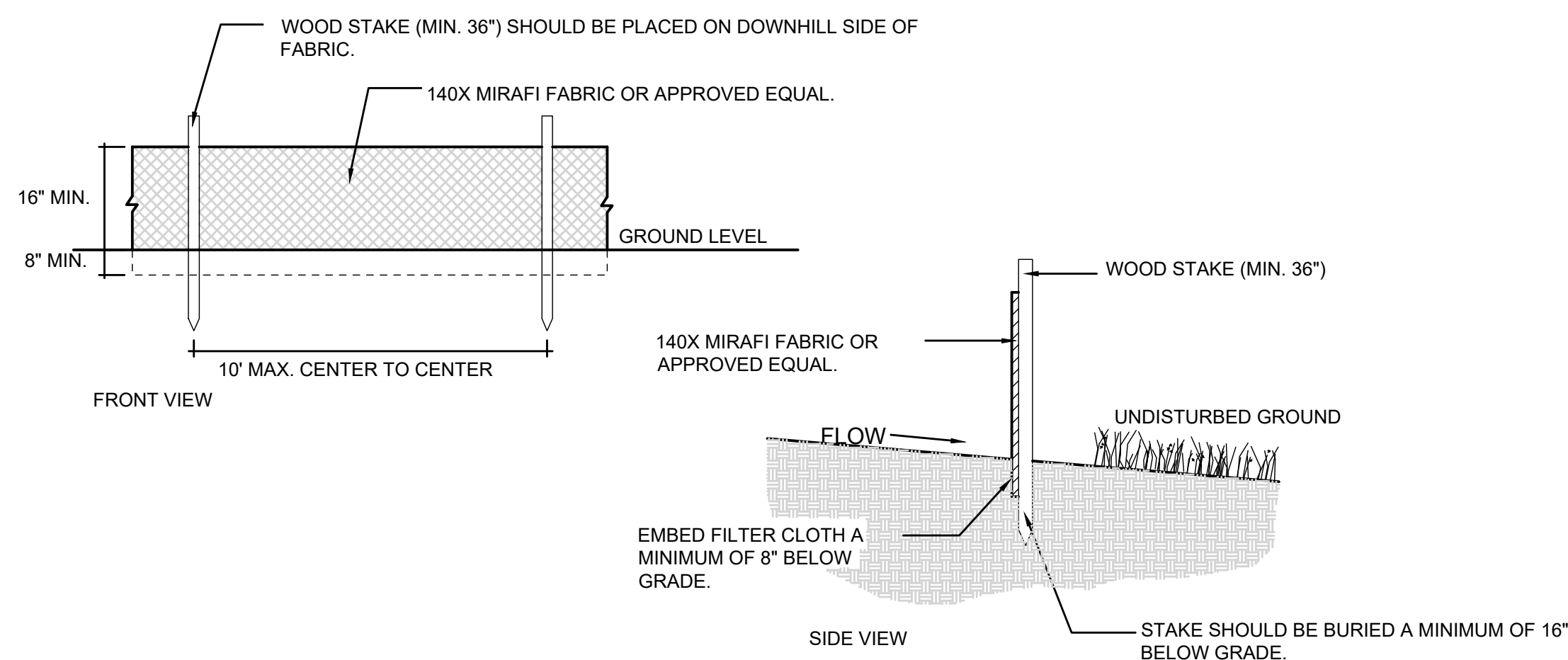
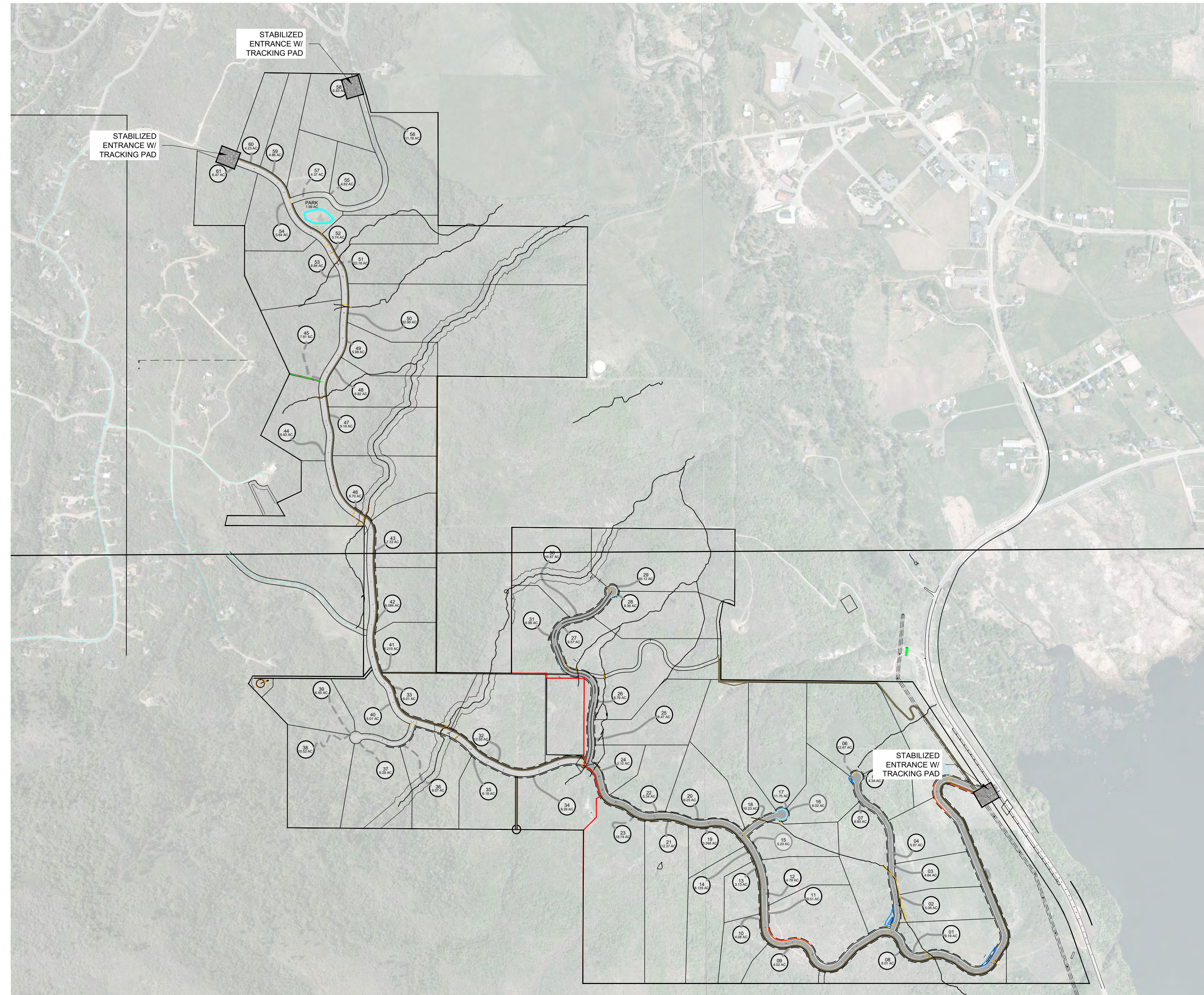
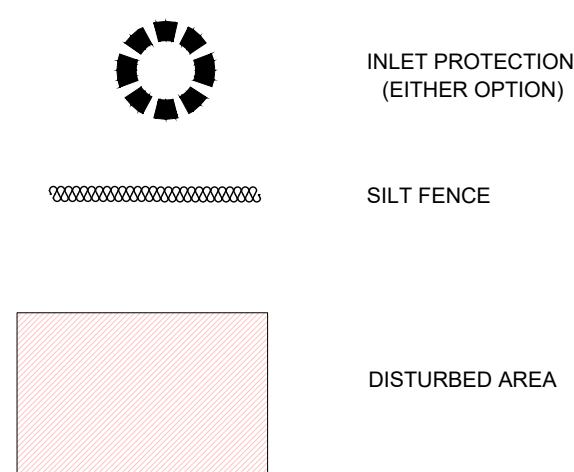

2 SILT FENCE

Scale: NTS

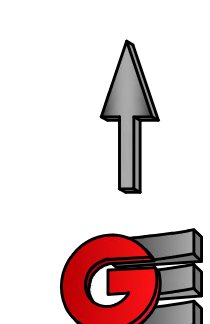
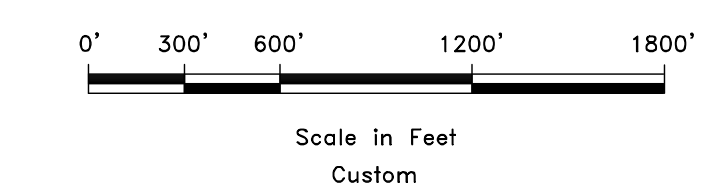
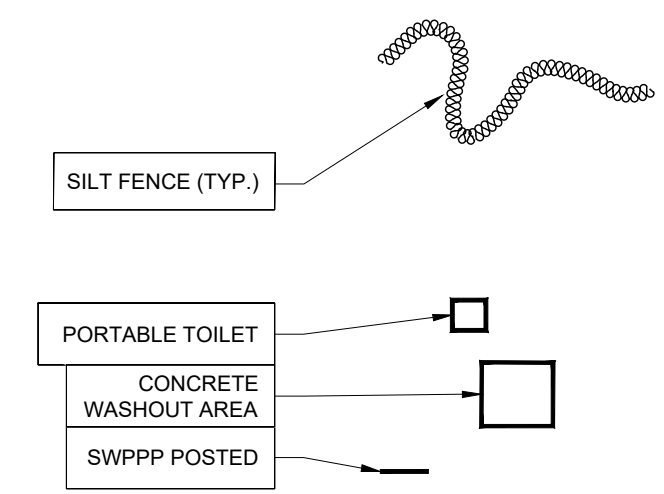

RM WATER PROTECTION PLAN

OSPREY RANCH

UT-158

EDEN, WEBER, UTAH

**GARDNER ENGINEERING**  
CIVIL - LAND PLANNING  
MUNICIPAL - LAND SURVEYING  
5150 SOUTH 375 EAST OGDEN, UT  
OFFICE: 801-476-0202 FAX: 801-476-0066

SWWP

REVISIONS	DESCRIPTION
DATE	

SCALE	*****
DATE	6-22-21
DESIGN	KAN
DRAWN	KAN
CHECKED	PC

DWG.





PLAN AND PROFILE ROAD A  
 OSPREY RANCH  
 UT-158  
 EDEN, WEBER, UTAH

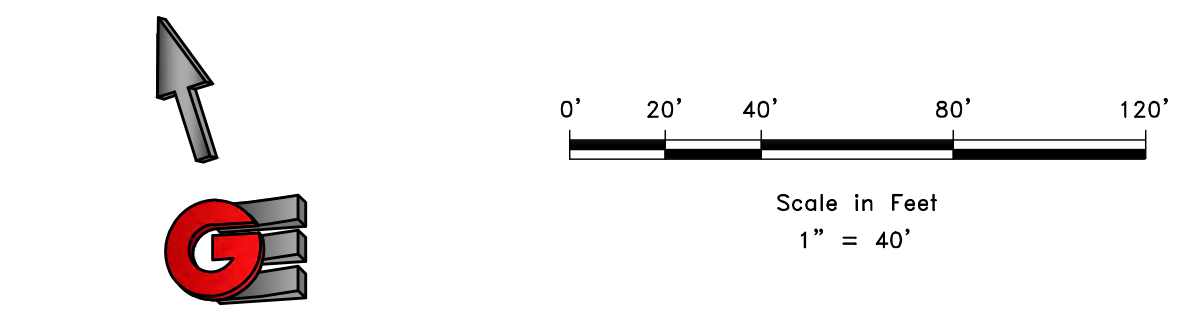
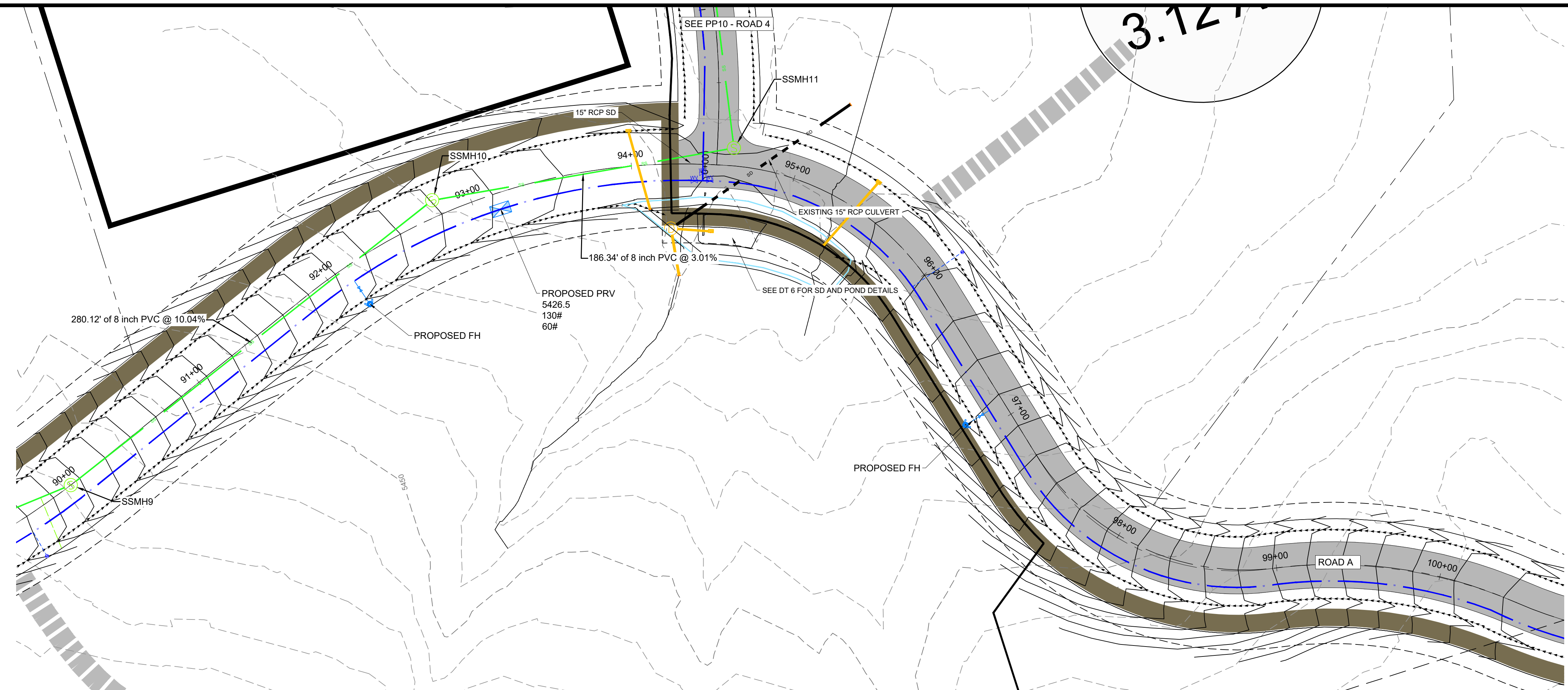

LOCATION MAP

- PROPOSED WATER - C900 DR14
- PROPOSED LOW PRESSURE SEWER SDR-11
- PROPOSED GRAVITY SEWER - SDR-35
- PROPOSED STORM DRAIN/CULVERT
- PROPOSED DRAINAGE DITCH

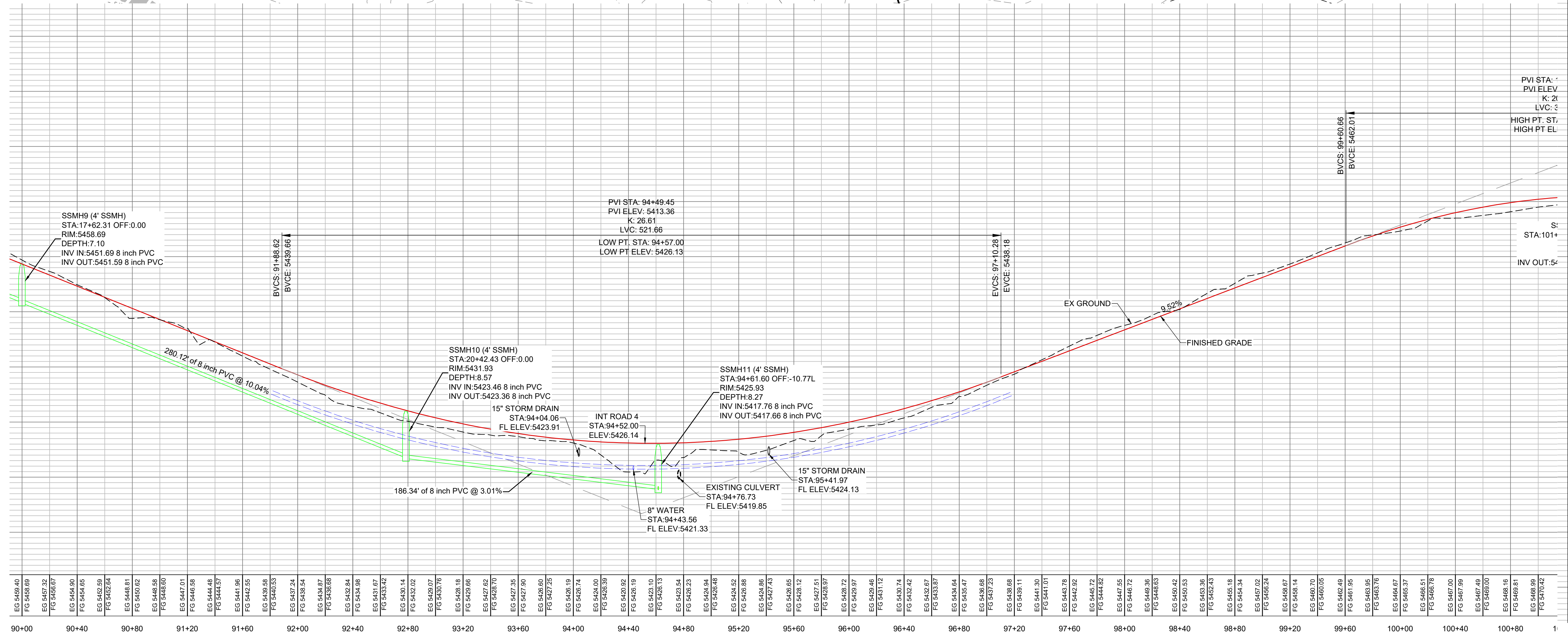

SCALE: 1" = 40'

DATE: 5-10-22

DESIGN: KAN

DRAWN: KAN

CHECKED: RC

REVISIONS	DATE	DESCRIPTION

DWG: \_\_\_\_\_

PLAN AND PROFILE ROAD A  
 OSPREY RANCH  
 UT-158  
 EDEN, WEBER, UTAH

**GARDNER ENGINEERING**  
 CIVIL • LAND PLANNING  
 MUNICIPAL • LAND SURVEYING  
 5150 SOUTH 375 EAST OGDEN, UT  
 OFFICE: 801-476-0202 FAX: 801-476-0066

PLAN AND PROFILE ROAD A  
 OSPREY RANCH  
 5150 SOUTH 375 EAST OGDEN, UT  
 OFFICE: 801-476-0202 FAX: 801-476-0066

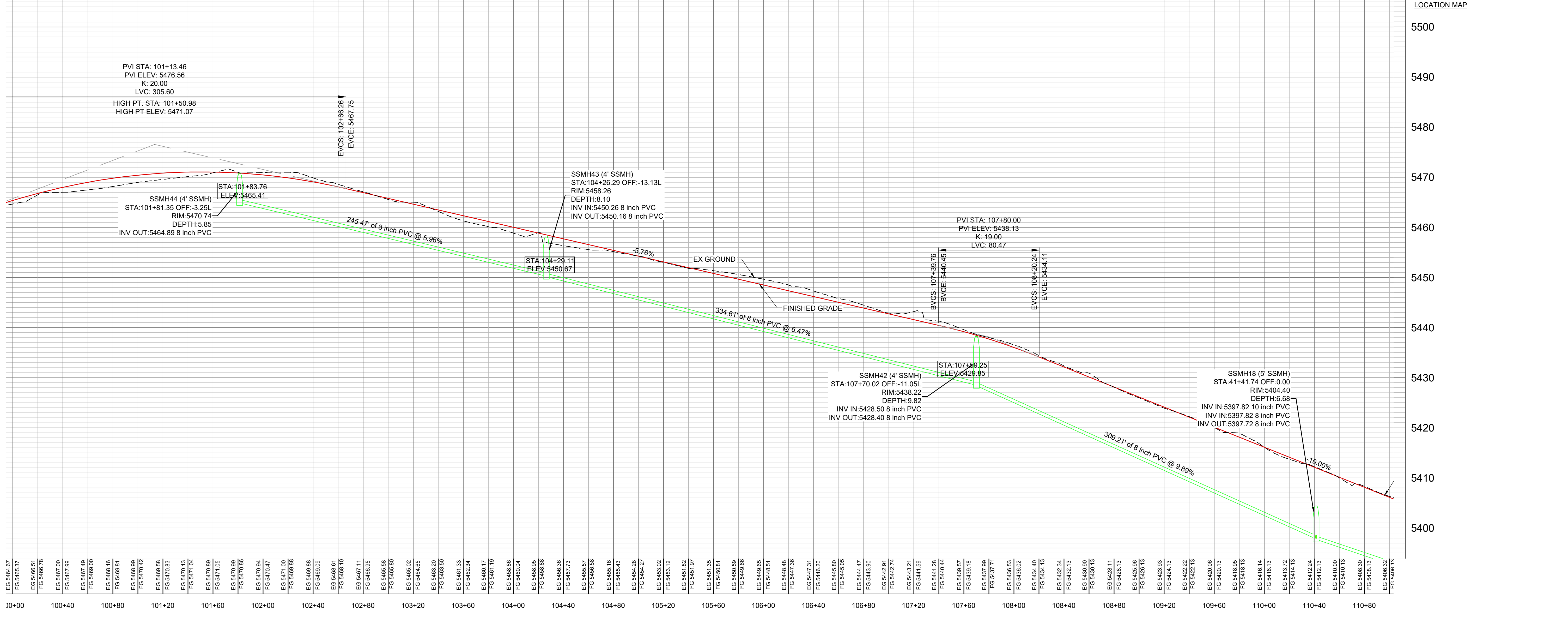
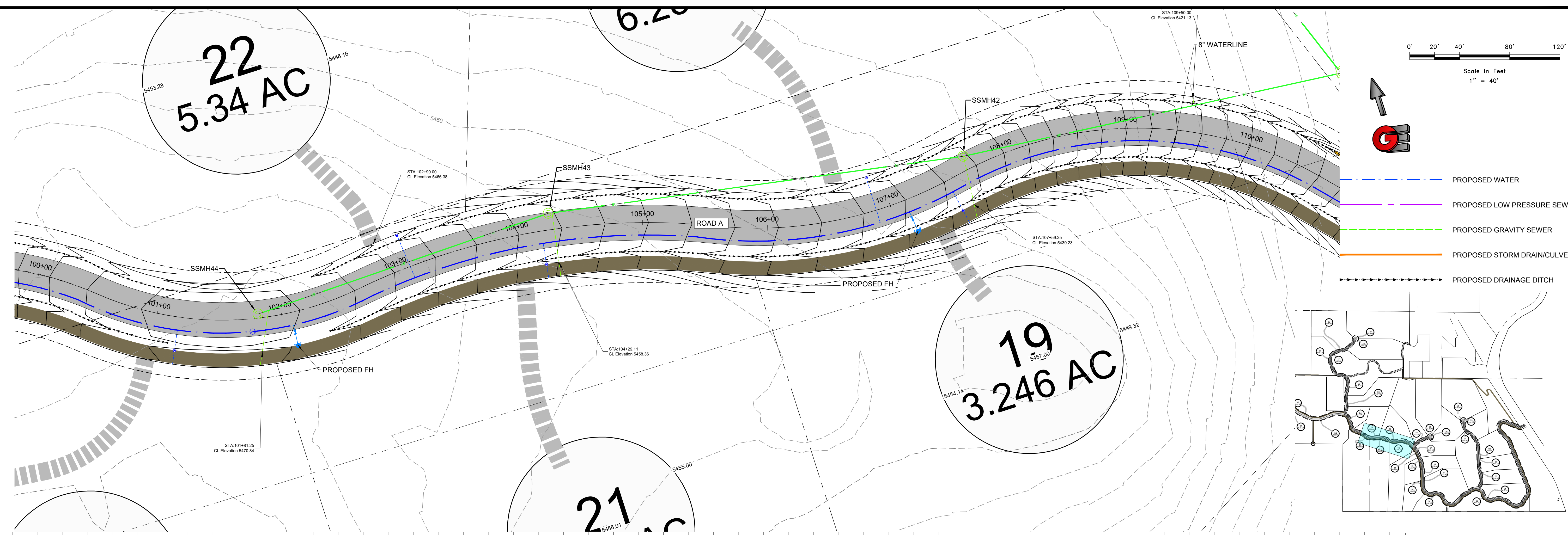

SCALE: 1" = 40'		DATE: 5-10-22	DESIGN: KAN	DRAWN: KAN	CHECKED: RC
REVISIONS		DESCRIPTION			
DATE					
DWG:					
PLAN AND PROFILE ROAD A					
OSPREY RANCH					
UT-158					
EDEN, WEBER, UTAH					



**GARDNER ENGINEERING**  
 CIVIL • LAND PLANNING  
 MUNICIPAL • LAND SURVEYING  
 5150 SOUTH 375 EAST OGDEN, UT  
 OFFICE: 801-476-0202 FAX: 801-476-0066

PP2

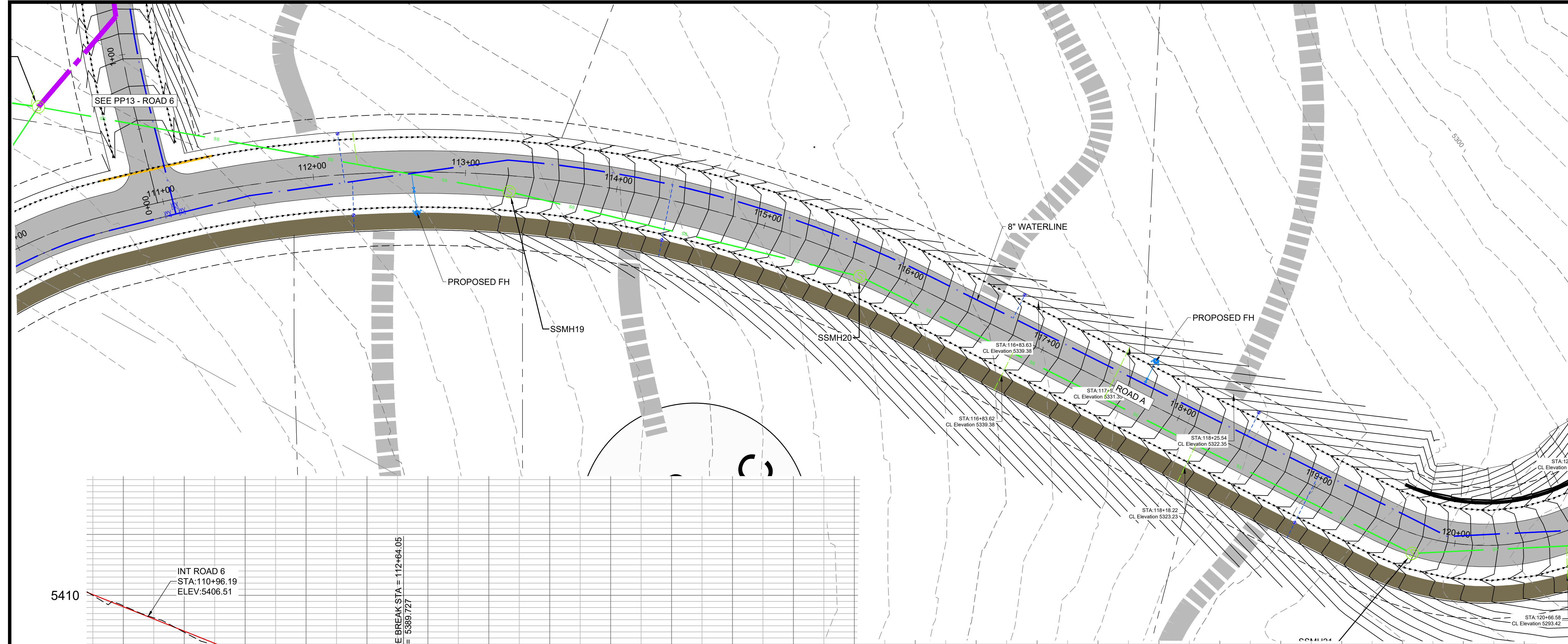

LOCATION MAP

- PROPOSED WATER - C900 DR14
- PROPOSED LOW PRESSURE SEWER SDR -11
- PROPOSED GRAVITY SEWER - SDR-35
- PROPOSED STORM DRAIN/CULVERT
- PROPOSED DRAINAGE DITCH

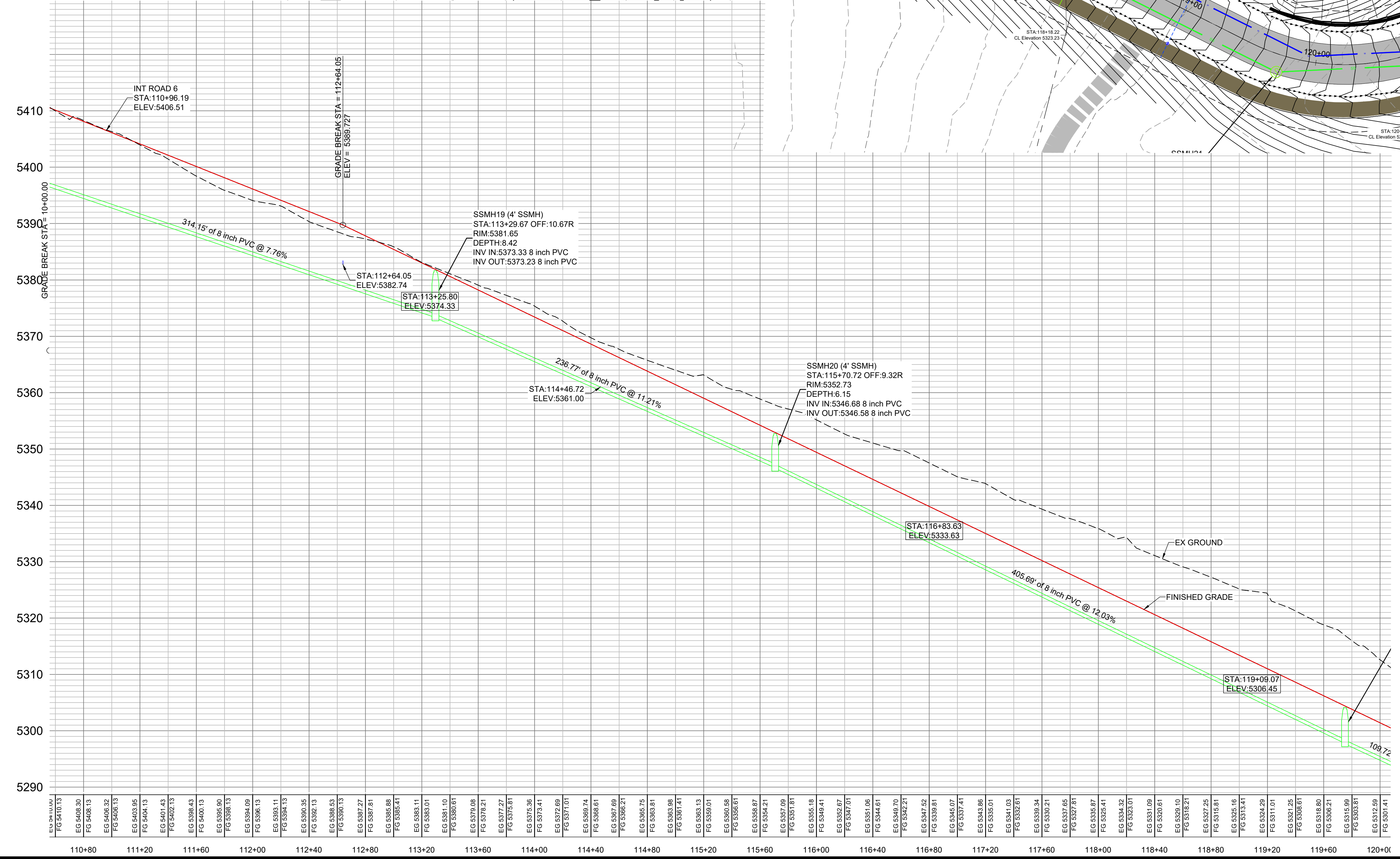

A:\2021 - LEWIS, HOWES & SONS - OSPREY RANCH\DESIGN\DWG\OSPREY PLAN PROFILE SHEETS PHASE 1 - RECOVER.RECOVER.DWG

SCALE	1" = 40'
DATE	5-10-22
DESIGN	KAN
DRAWN	KAN
CHECKED	RC

REVISIONS	DESCRIPTION
DATE	

DWG:

PLAN AND PROFILE ROAD A  
OSPREY RANCH  
UT-158  
EDEN, WEBER, UTAH

**GARDNER ENGINEERING**  
CIVIL • LAND PLANNING  
MUNICIPAL • LAND SURVEYING

5150 SOUTH 375 EAST OGDEN, UT  
OFFICE: 801-476-0202 FAX: 801-476-0066

PP3

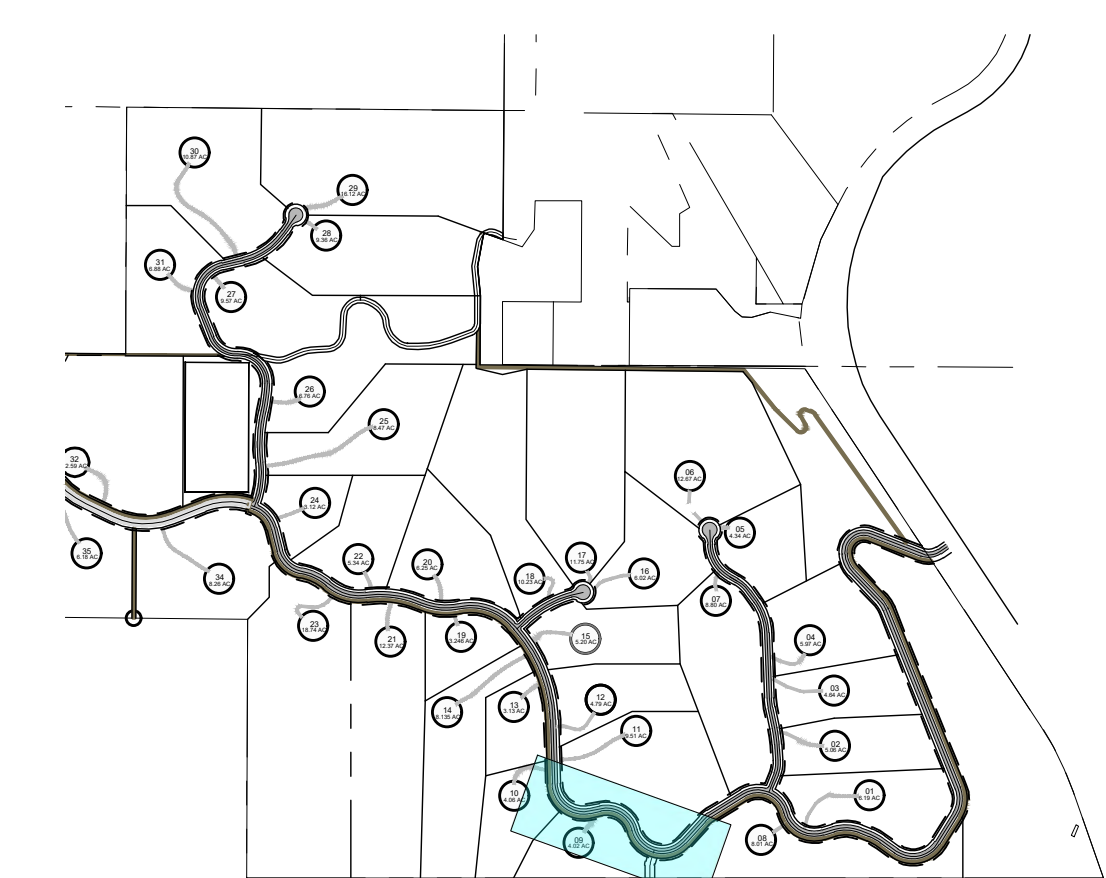
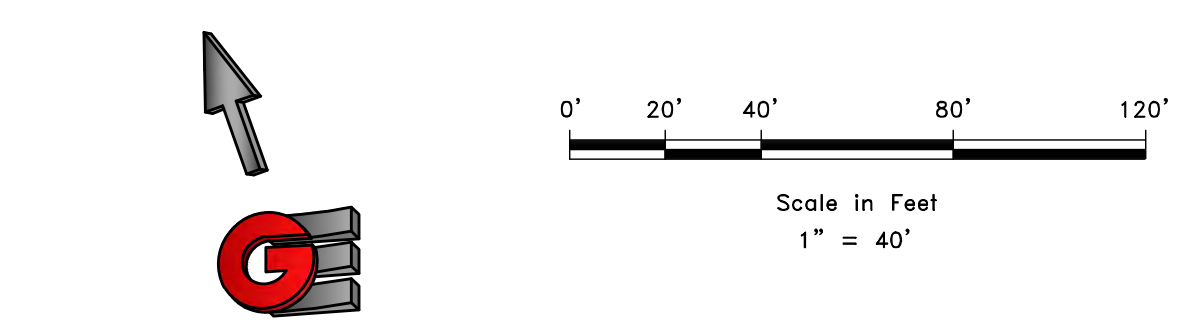
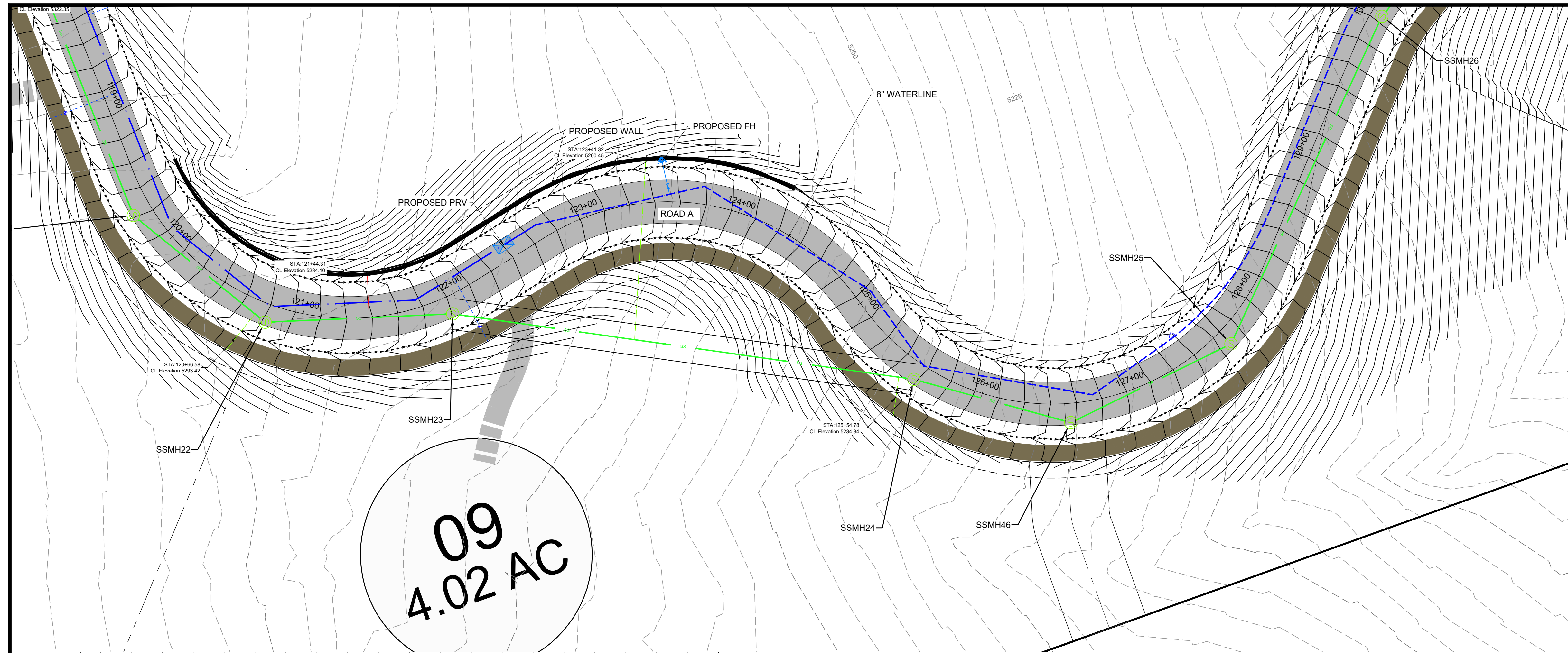

LOCATION MAP

- PROPOSED WATER - C900 DR14
- PROPOSED LOW PRESSURE SEWER SDR-11
- PROPOSED GRAVITY SEWER - SDR-35
- PROPOSED STORM DRAIN/CULVERT
- PROPOSED DRAINAGE DITCH

09  
4.02 AC

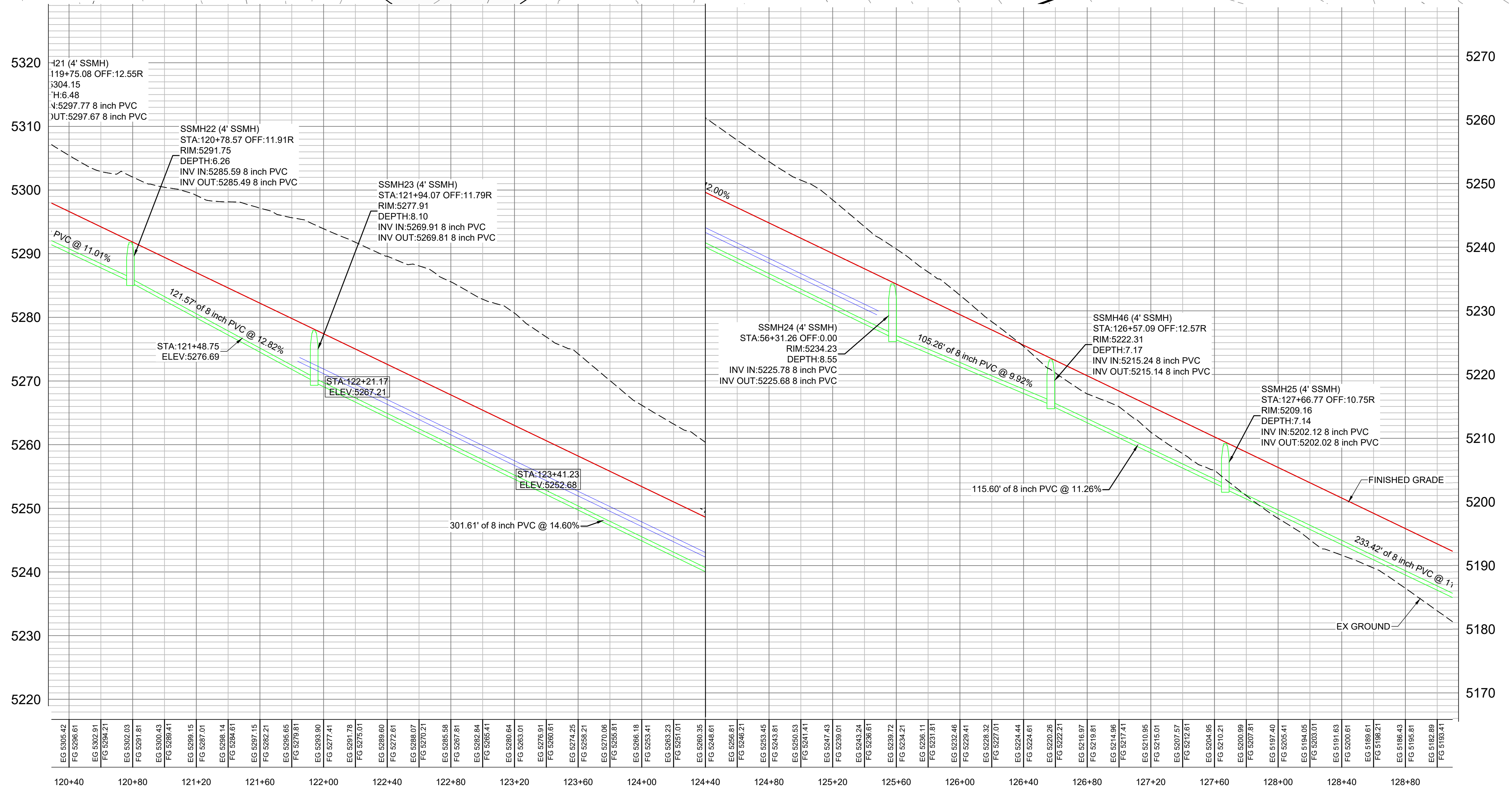

A:\1201 - LEWIS, HOMES, 2105 - OSPREY RANCH\DESIGN\DWG\OSPREY PLAN PROFILE SHEETS\PHASE 1 - RECOVER RECORD.DWG

SCALE	1" = 40'
DATE	5-10-22
DESIGN	KAN
DRAWN	KAN
CHECKED	RC

REVISIONS	DESCRIPTION
DATE	

DWG:	
------	--

PLAN AND PROFILE ROAD A  
OSPREY RANCH  
UT-158  
EDEN, WEBER, UTAH

**GARDNER ENGINEERING**  
CIVIL • LAND PLANNING  
MUNICIPAL • LAND SURVEYING  
5150 SOUTH 375 EAST OGDEN, UT  
OFFICE: 801-476-0202 FAX: 801-476-0066

PP4

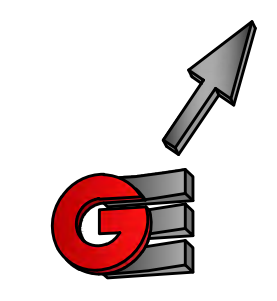
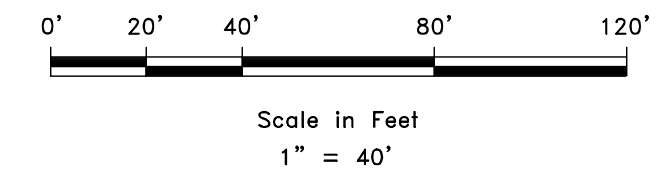
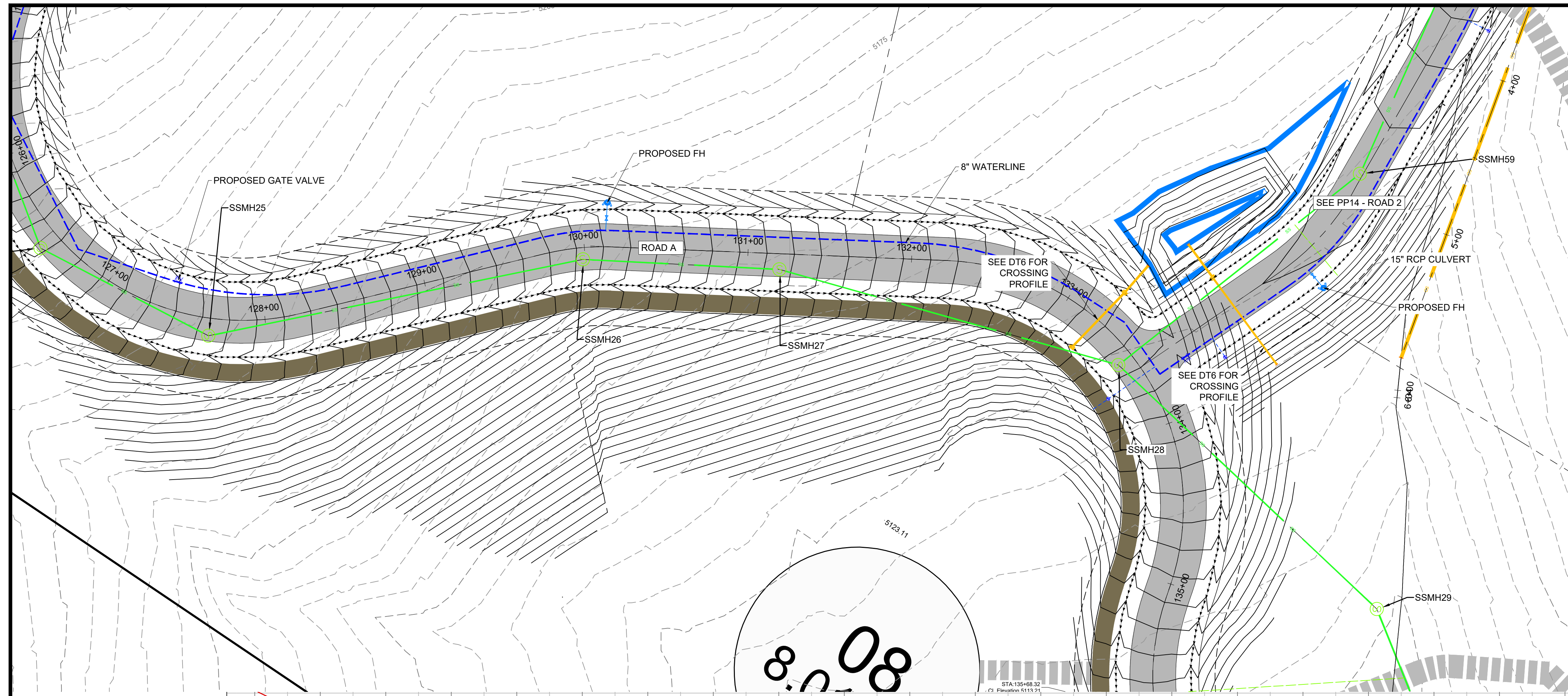

LOCATION MAP

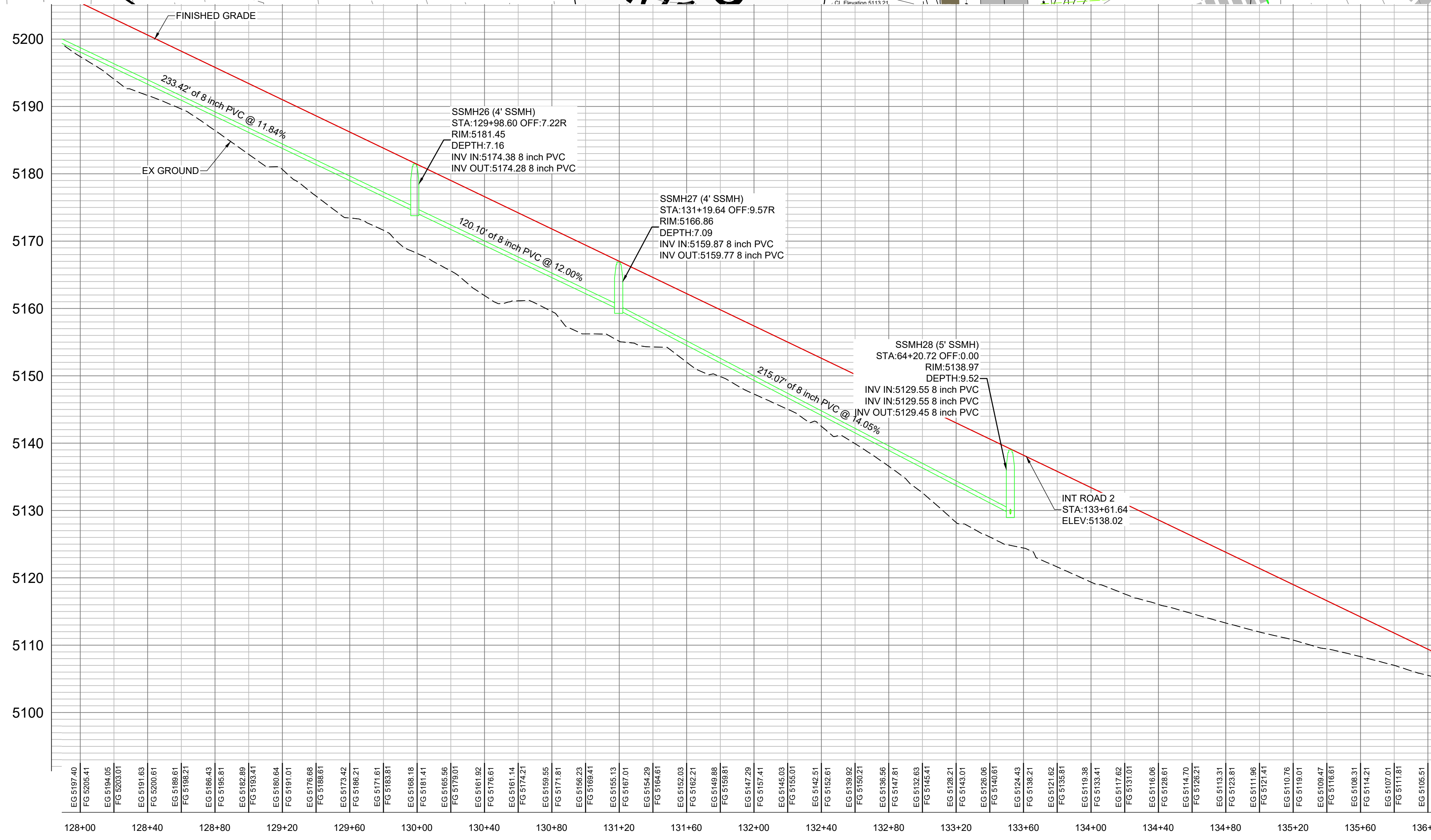

- PROPOSED WATER - C900 DR14
- PROPOSED LOW PRESSURE SEWER SDR-11
- PROPOSED GRAVITY SEWER - SDR-35
- PROPOSED STORM DRAIN/CULVERT
- PROPOSED DRAINAGE DITCH

REVISIONS	
DATE	DESCRIPTION

SCALE: 1" = 40'
DATE: 5/10/22
DESIGN: KAN
DRAWN: KAN
CHECKED: RC

**PLAN AND PROFILE ROAD A**  
**OSPREY RANCH**  
**UT-158**  
**EDEN, WEBER, UTAH**

**GARDNER ENGINEERING**  
 CIVIL • LAND PLANNING  
 MUNICIPAL • LAND SURVEYING  
 51150 SOUTH 375 EAST OGDEN, UT  
 OFFICE: 801-476-0202 FAX: 801-476-0066

A:\1201 - EDEN, WEBER, UTAH - OSPREY RANCH\DESIGN\DWG\OSPREY PLAN PROFILE SHEETS\SHASE - RECORD\RECOVER.DWG

PLAN AND PROFILE ROAD A  
 OSPREY RANCH  
 UT-158  
 EDEN, WEBER, UTAH

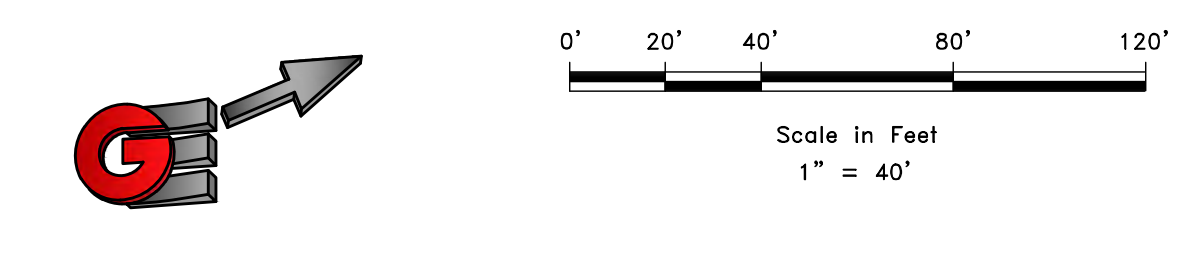
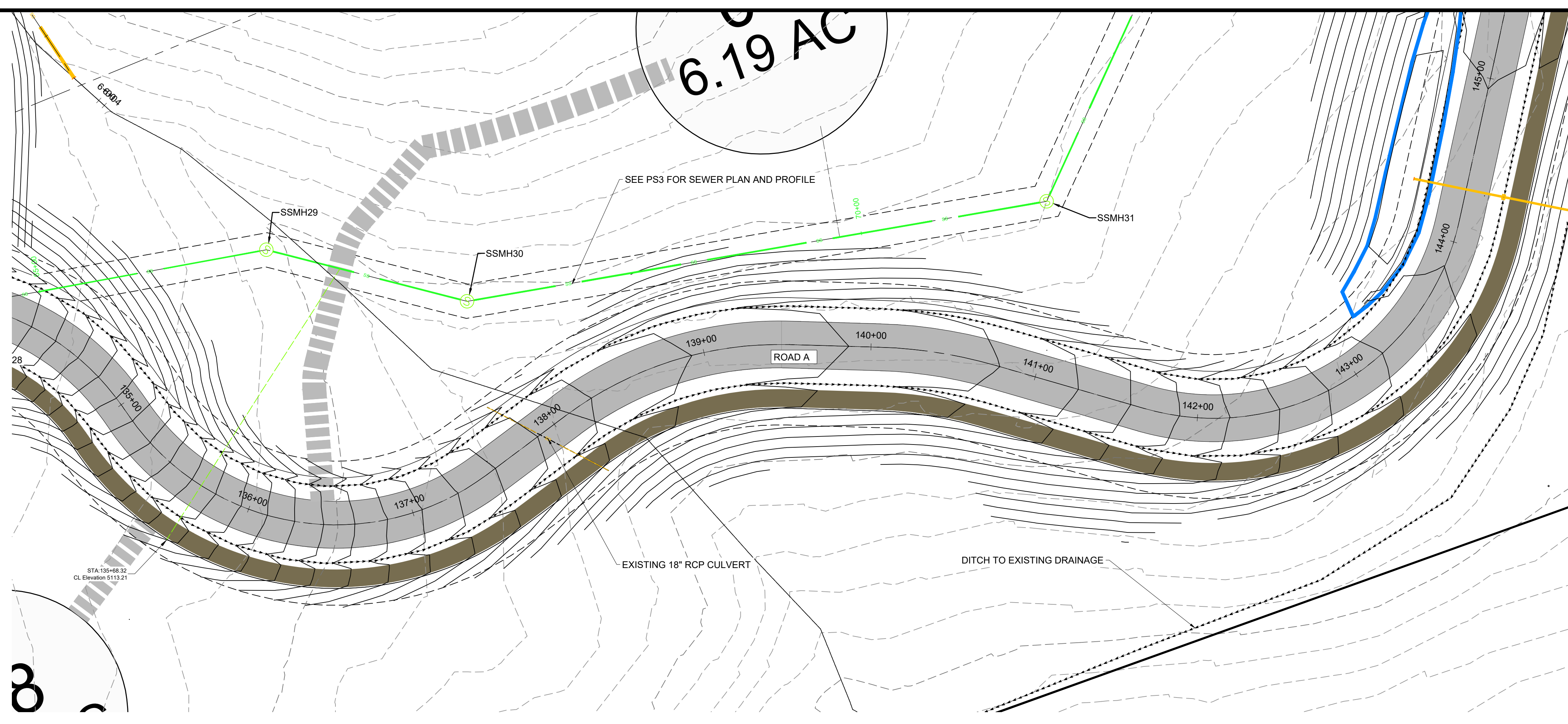

LOCATION MAP

- PROPOSED WATER - C900 DR14
- PROPOSED LOW PRESSURE SEWER SDR - 11
- PROPOSED GRAVITY SEWER - SDR-35
- PROPOSED STORM DRAIN/CULVERT
- PROPOSED DRAINAGE DITCH

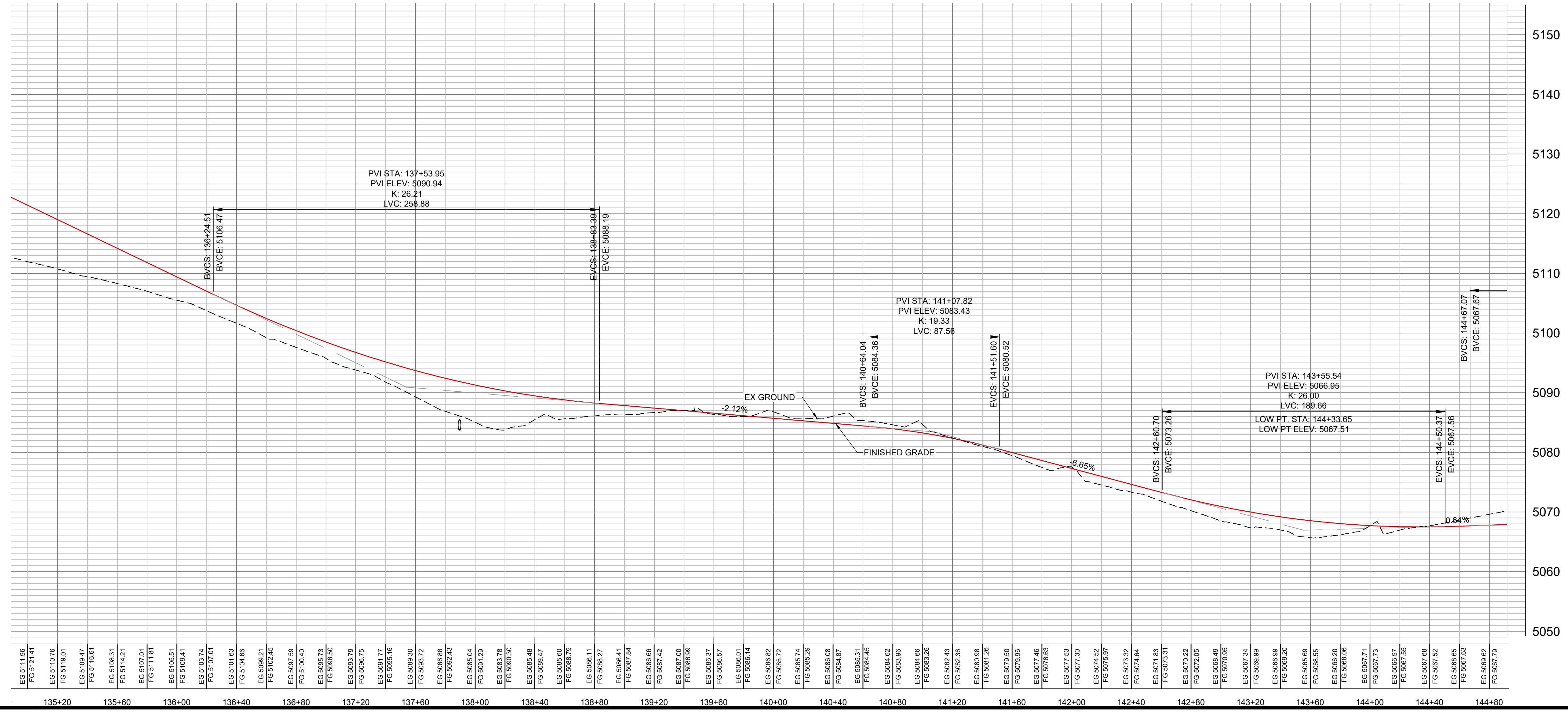

<b>PLAN AND PROFILE ROAD A</b> <b>OSPREY RANCH</b> <b>UT-158</b> <b>EDEN, WEBER, UTAH</b>										
<table border="1" style="width: 100%; border-collapse: collapse;"> <thead> <tr> <th style="width: 20%;">REVISIONS</th> <th style="width: 80%;">DESCRIPTION</th> </tr> </thead> <tbody> <tr> <td>DATE</td> <td></td> </tr> </tbody> </table>	REVISIONS	DESCRIPTION	DATE		<table border="1" style="width: 100%; border-collapse: collapse;"> <tr> <td>SCALE: 1" = 40'</td> </tr> <tr> <td>DATE: 5-10-22</td> </tr> <tr> <td>DESIGN: KAN</td> </tr> <tr> <td>DRAWN: KAN</td> </tr> <tr> <td>CHECKED: RC</td> </tr> </table>	SCALE: 1" = 40'	DATE: 5-10-22	DESIGN: KAN	DRAWN: KAN	CHECKED: RC
REVISIONS	DESCRIPTION									
DATE										
SCALE: 1" = 40'										
DATE: 5-10-22										
DESIGN: KAN										
DRAWN: KAN										
CHECKED: RC										
 <b>GARDNER ENGINEERING</b> CIVIL • LAND PLANNING MUNICIPAL • LAND SURVEYING 5150 SOUTH 375 EAST OGDEN, UT OFFICE: 801-476-0202 FAX: 801-476-0066										
<b>PP6</b>										

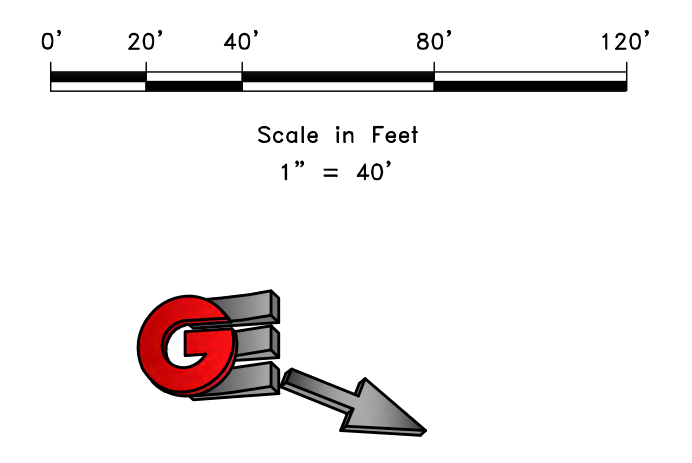
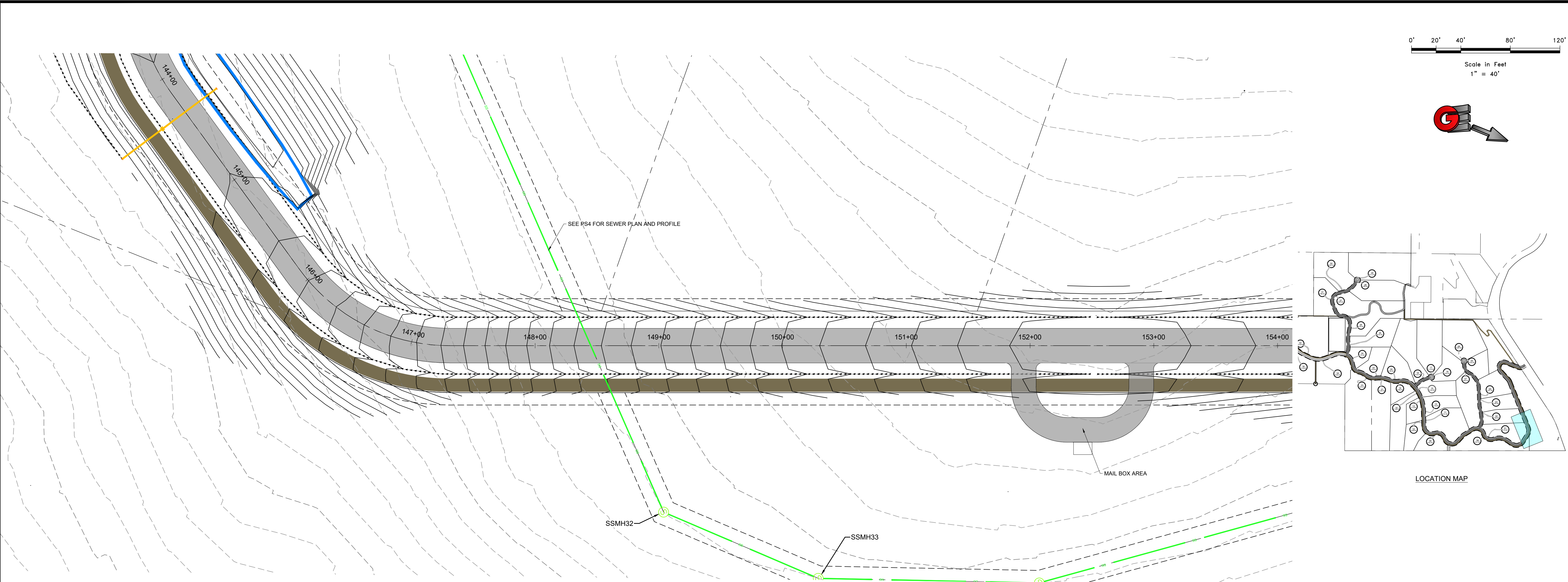
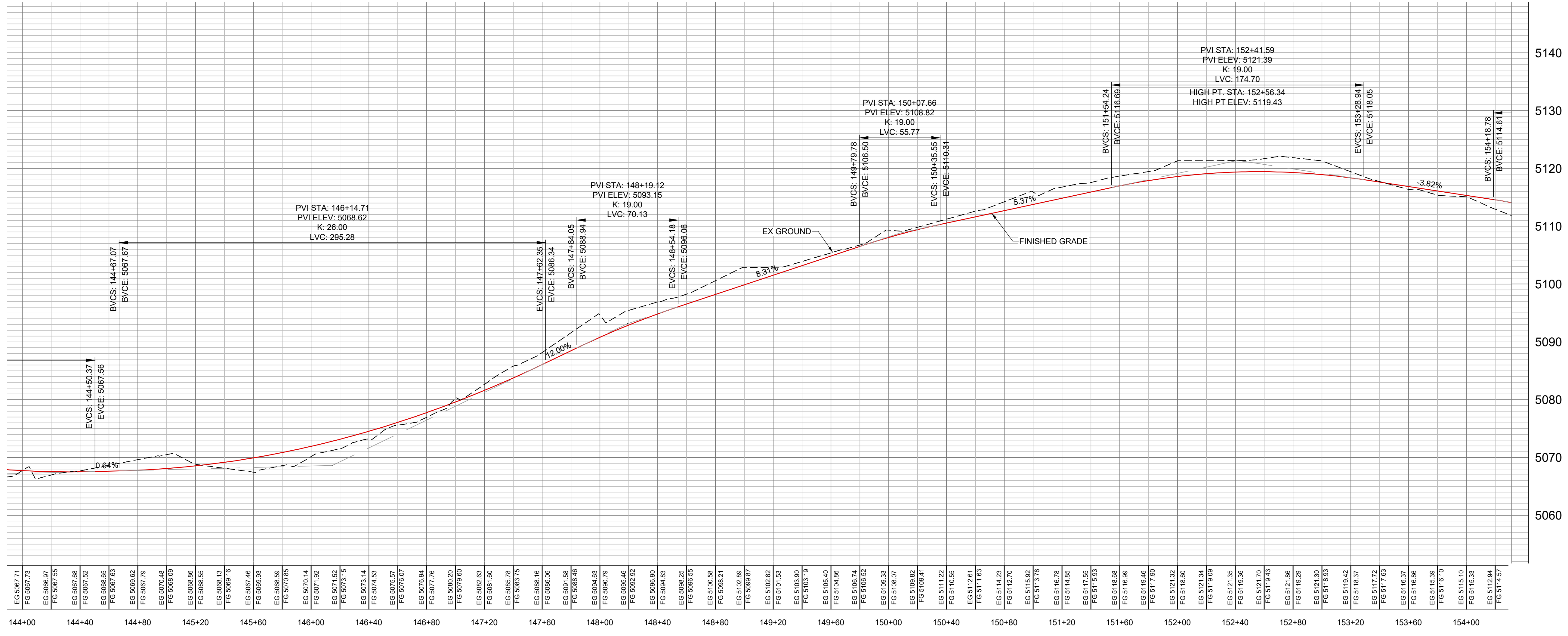

<p><b>GARDNER ENGINEERING</b> CIVIL • LAND PLANNING MUNICIPAL • LAND SURVEYING</p> <p>5150 SOUTH 375 EAST OGDEN, UT OFFICE: 801-476-0202 FAX: 801-476-0066</p>		<p>SCALE: 1" = 40'</p> <p>DATE: 5-10-22</p> <p>DESIGN: KAN</p> <p>DRAWN: KAN</p> <p>CHECKED: RC</p>						
<p>PLAN AND PROFILE ROAD A</p> <p>OSPREY RANCH</p> <p>UT-158</p> <p>EDEN, WEBER, UTAH</p>		<table border="1"> <thead> <tr> <th>REVISIONS</th> <th>DATE</th> <th>DESCRIPTION</th> </tr> </thead> <tbody> <tr> <td> </td> <td> </td> <td> </td> </tr> </tbody> </table>	REVISIONS	DATE	DESCRIPTION			
REVISIONS	DATE	DESCRIPTION						
<p>PP7</p>		<p>DWG:</p>						





PLAN AND PROFILE ROAD A - OSPREY RANCH, WEBER COUNTY, UTAH - CIVIL ENGINEERING - PHASE 1 - RECOVER - RESURFACING

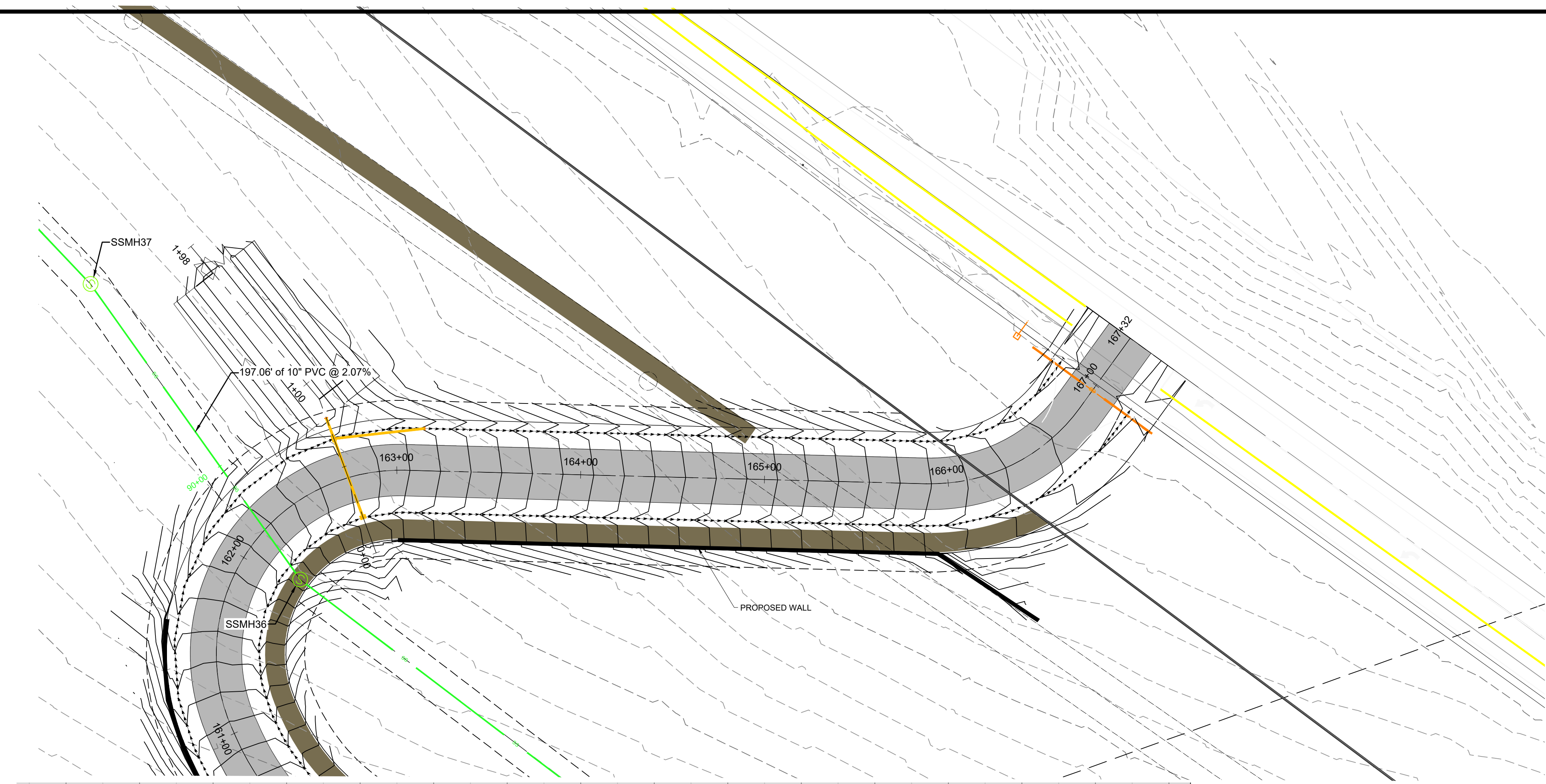

LOCATION MAP

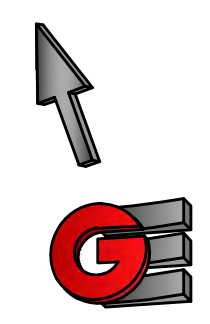
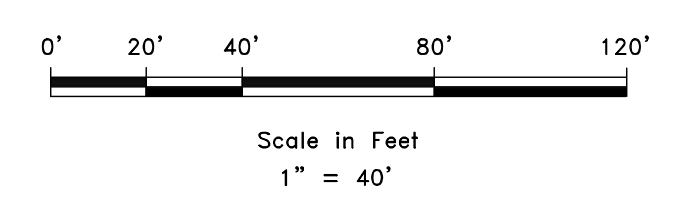
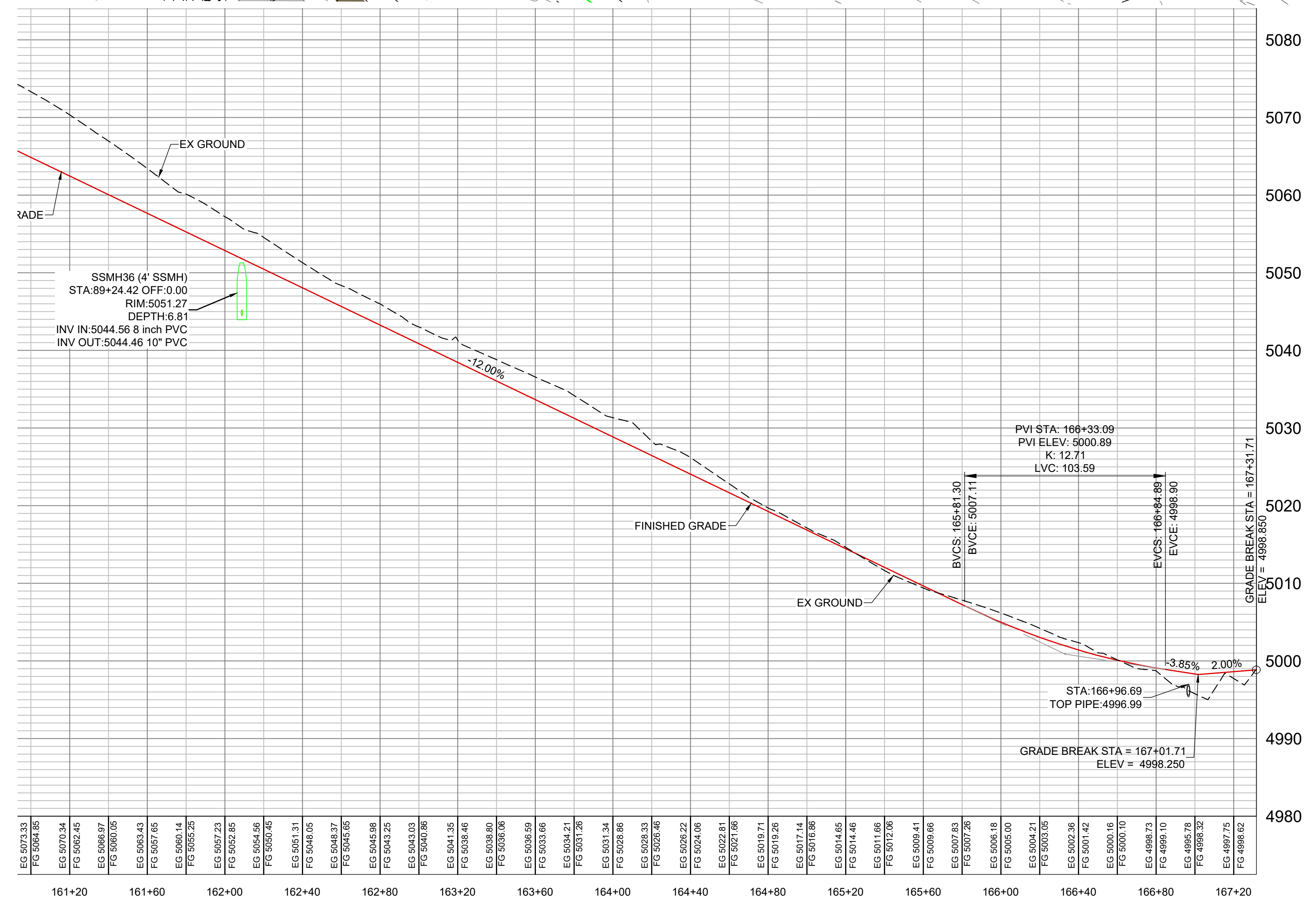

REVISIONS	DATE	DESCRIPTION

SCALE: 1" = 40'
DATE: 5/19/22
DESIGN: KAN
DRAWN: KAN
CHECKED: RC

PLAN AND PROFILE ROAD A  
 OSPREY RANCH  
 UT-158  
 EDEN, WEBER, UTAH

**GARDNER ENGINEERING**  
 CIVIL • LAND PLANNING  
 MUNICIPAL • LAND SURVEYING  
 5150 SOUTH 375 EAST OGDEN, UT  
 OFFICE: 801-476-0202 FAX: 801-476-0066

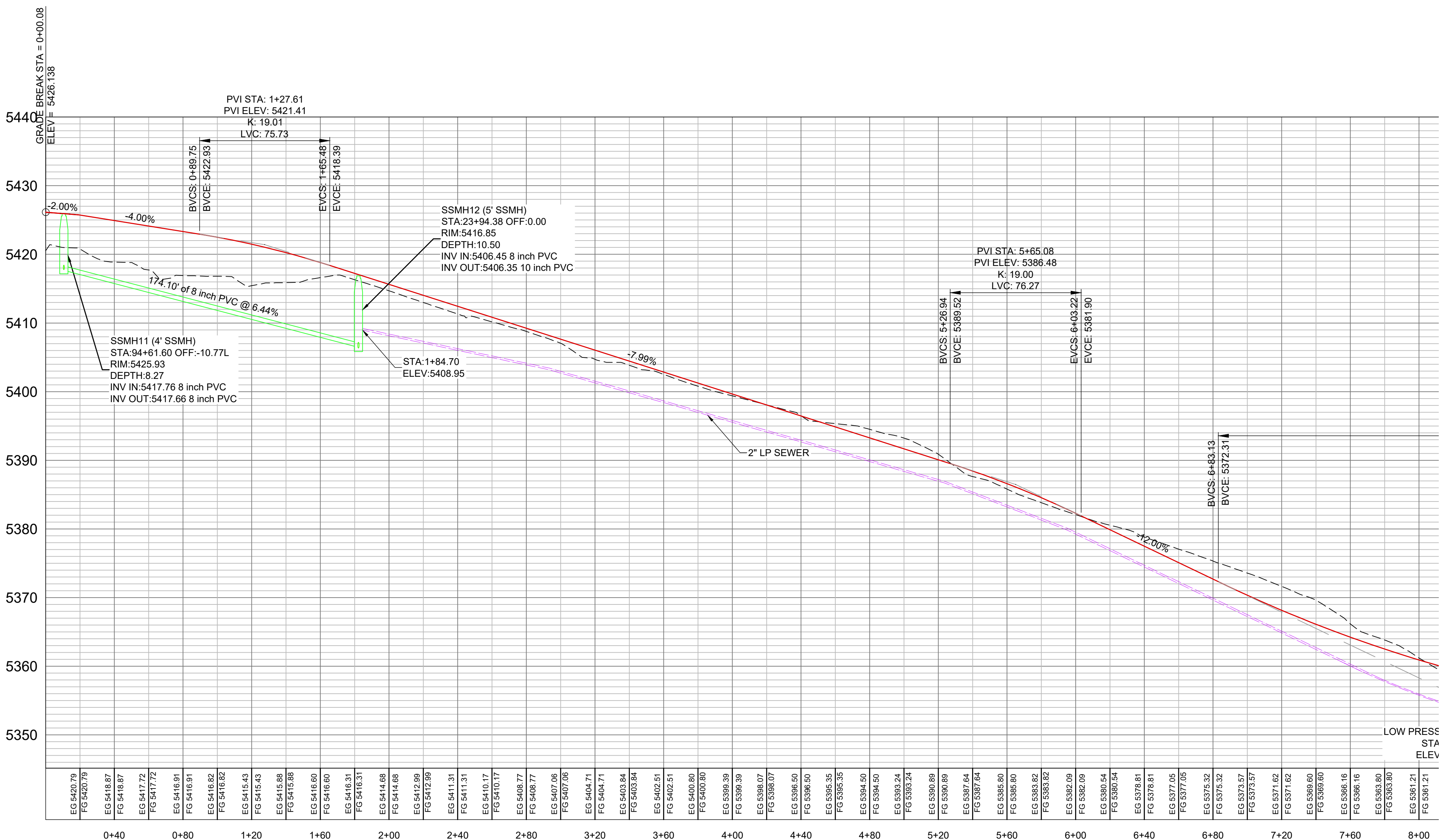
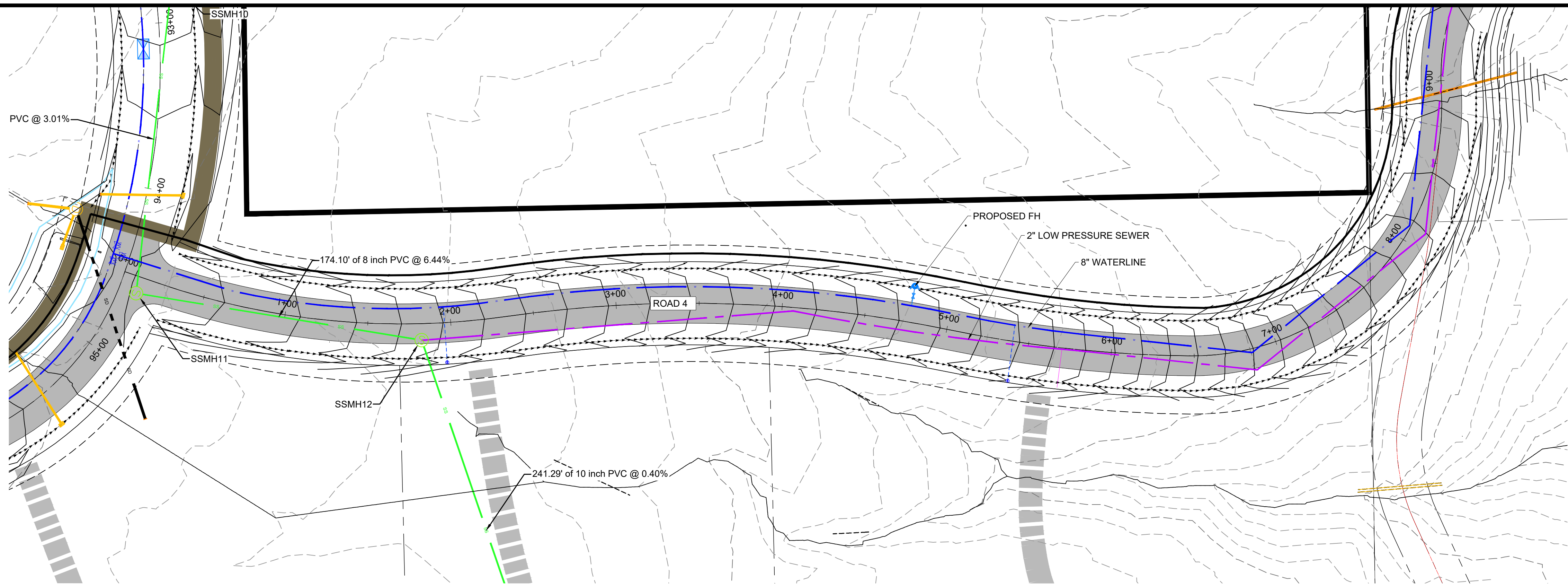

- - - - - PROPOSED WATER - C900 DR14
- - - - - PROPOSED LOW PRESSURE SEWER SDR -11
- - - - - PROPOSED GRAVITY SEWER - SDR-35
- PROPOSED STORM DRAIN/CULVERT
- - - - - PROPOSED DRAINAGE DITCH

SCALE	1" = 40'
DATE	5-10-22
DESIGN	KAN
DRAWN	KAN
CHECKED	RC

REVISIONS	DATE	DESCRIPTION

DWG:	
------	--

**PLAN AND PROFILE ROAD 4**  
**OSPREY RANCH**  
**UT-158**  
**EDEN, WEBER, UTAH**

**GARDNER ENGINEERING**  
 CIVIL • LAND PLANNING  
 MUNICIPAL • LAND SURVEYING  
 5150 SOUTH 375 EAST OGDEN, UT  
 OFFICE: 801.476.0202 FAX: 801.476.0066

A:\1201 - LEWIS, HOMER\1205 - OSPREY RANCH\DESIGN\DWG\OSPREY PLAN PROFILE SHEETS\PHASE 4 - RECOVER RECOVER.DWG

BA 1201 - LEWIS, HOMES 2105 - OSPREY RANCH, BENCH MARK, OSPREY PLAN, PROFILE SHEETS PHASE 1 - RECOVER, RECOVER.DWG

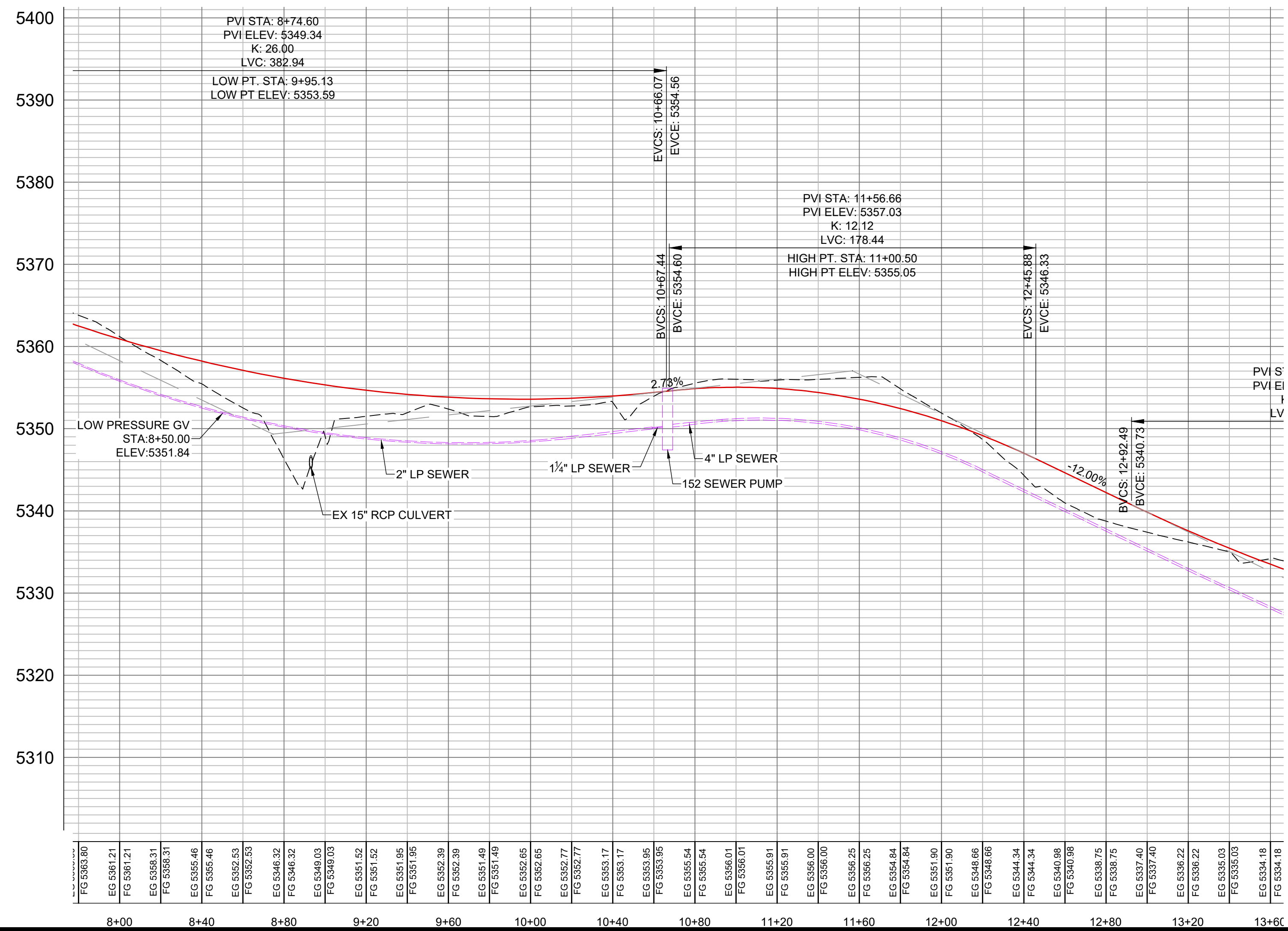
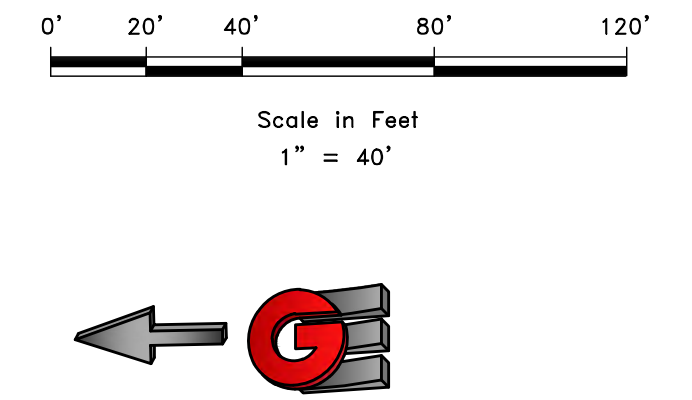
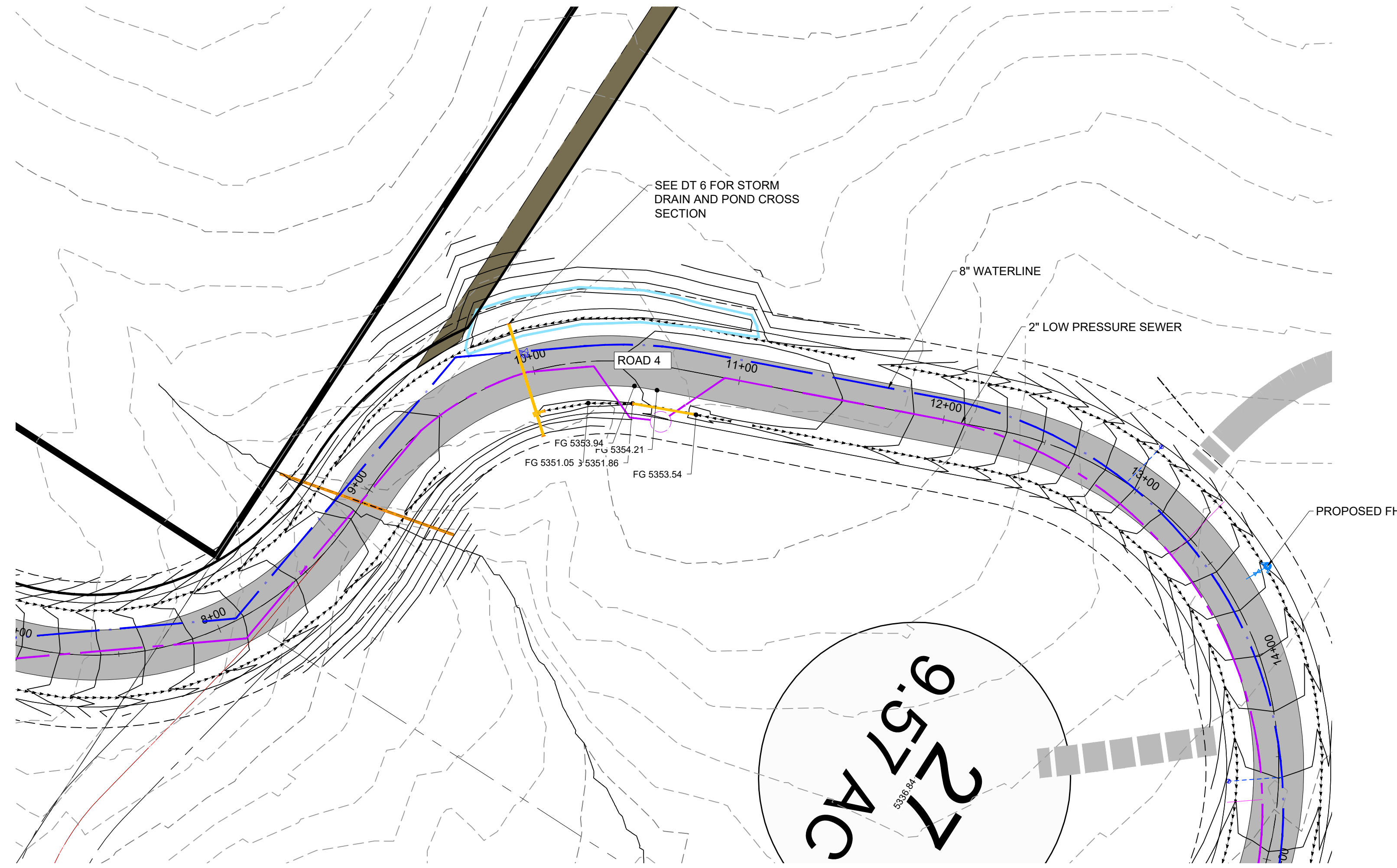

- PROPOSED WATER - C900 DR14
- PROPOSED LOW PRESSURE SEWER SDR -11
- PROPOSED GRAVITY SEWER - SDR-35
- PROPOSED STORM DRAIN/CULVERT
- PROPOSED DRAINAGE DITCH

<b>PLAN AND PROFILE ROAD 4</b> <b>OSPREY RANCH</b> <b>UT-158</b> <b>EDEN, WEBER, UTAH</b>																	
<table border="1" style="width: 100%; border-collapse: collapse;"> <thead> <tr> <th style="width: 30%;">DATE</th> <th style="width: 70%;">DESCRIPTION</th> </tr> </thead> <tbody> <tr> <td> </td> <td> </td> </tr> <tr> <td> </td> <td> </td> </tr> <tr> <td> </td> <td> </td> </tr> </tbody> </table>	DATE	DESCRIPTION							<table border="1" style="width: 100%; border-collapse: collapse;"> <thead> <tr> <th style="width: 30%;">DATE</th> <th style="width: 70%;">DESCRIPTION</th> </tr> </thead> <tbody> <tr> <td> </td> <td> </td> </tr> <tr> <td> </td> <td> </td> </tr> <tr> <td> </td> <td> </td> </tr> </tbody> </table>	DATE	DESCRIPTION						
DATE	DESCRIPTION																
DATE	DESCRIPTION																
<p><b>GARDNER ENGINEERING</b>          CIVIL • LAND PLANNING          MUNICIPAL • LAND SURVEYING          5150 SOUTH 375 EAST OGDEN, UT          OFFICE: 801-476-0202 FAX: 801-476-0066</p>																	
<p>PP11</p>																	

A:\1201 - LEWIS HOMES\1205 - OSPREY RANCH\DESIGN\DWG\OSPREY PLAN PROFILE SHEETS PHASE 4 - RECOVER\_ARECOVER.DWG

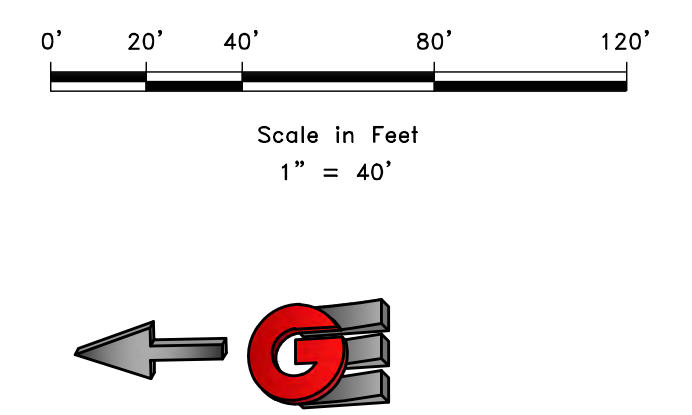
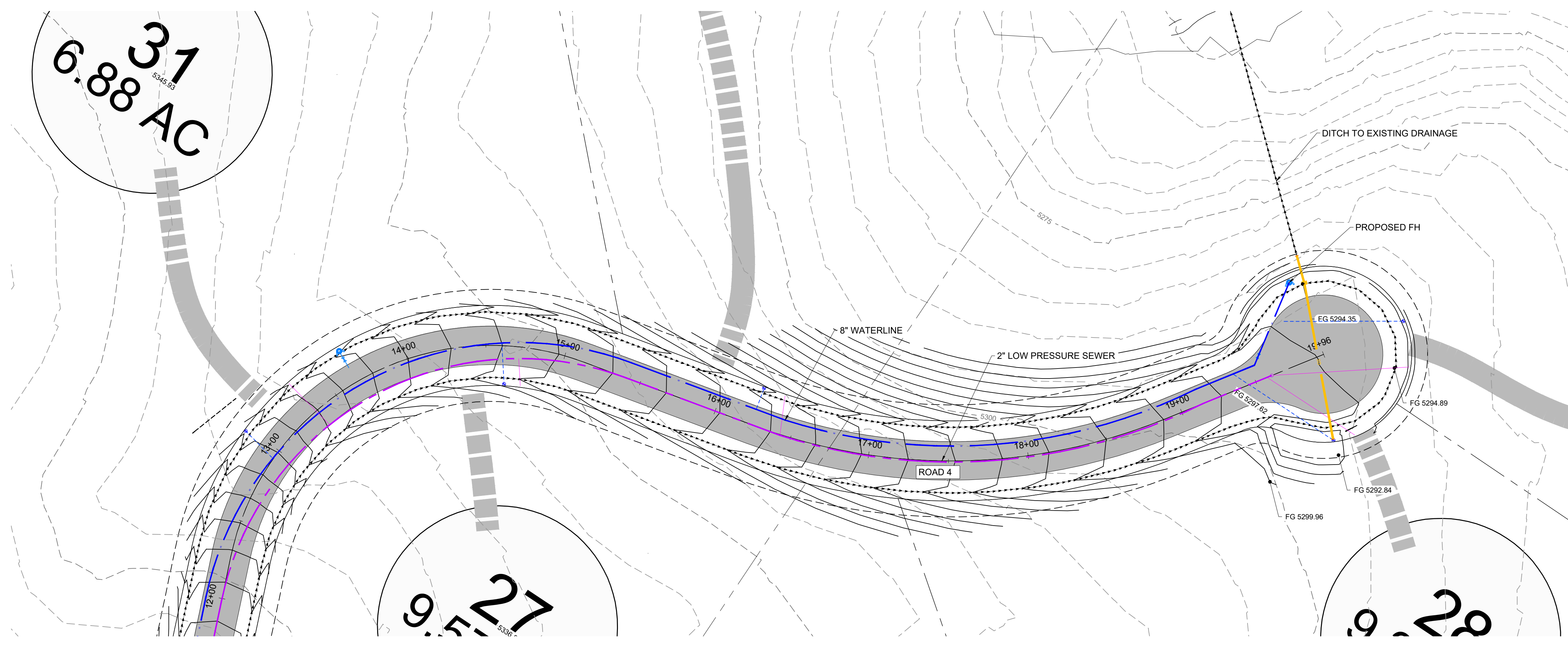

LOCATION MAP

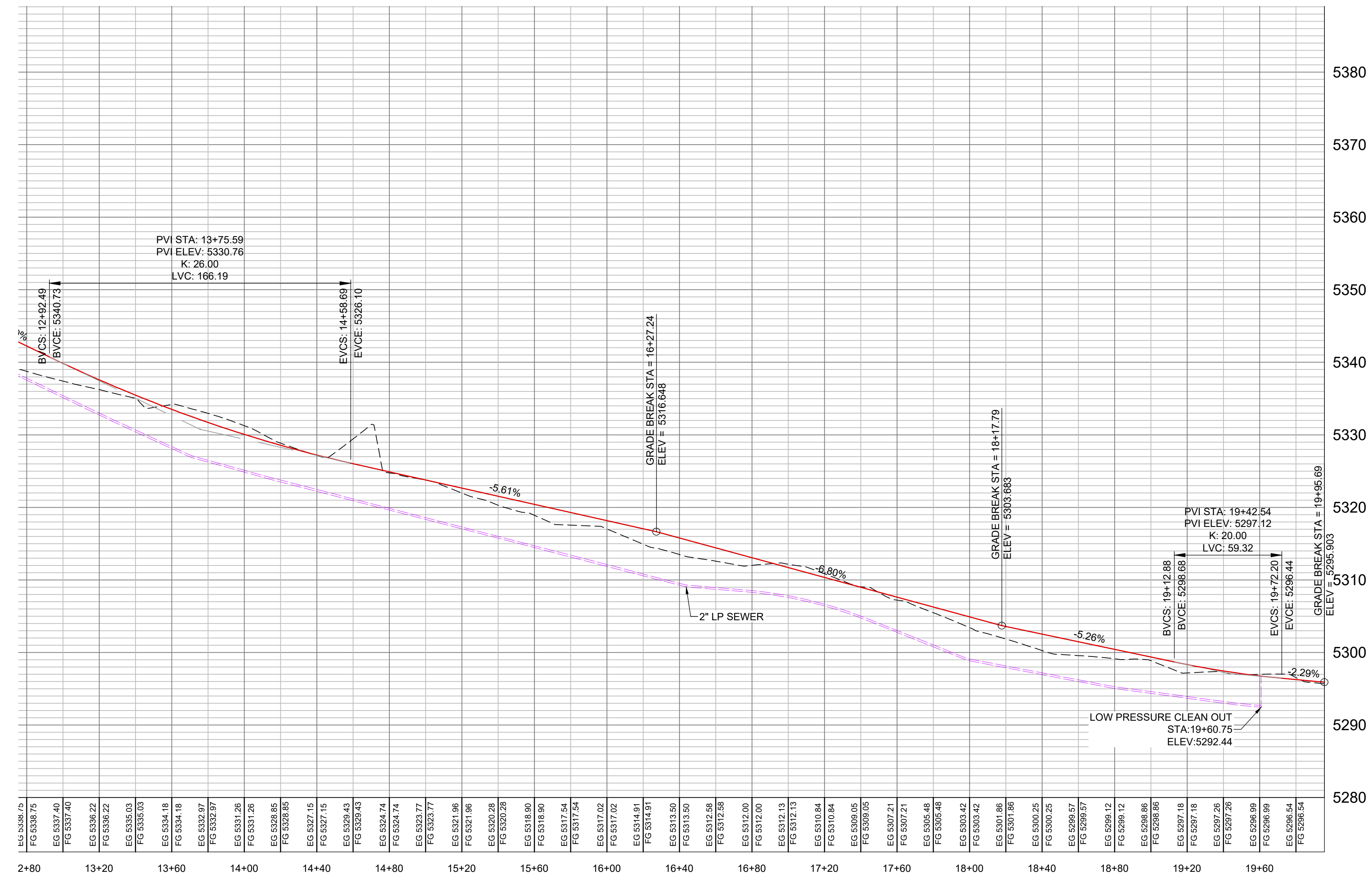

- PROPOSED WATER - C900 DR14
- PROPOSED LOW PRESSURE SEWER SDR-11
- PROPOSED GRAVITY SEWER - SDR-35
- PROPOSED STORM DRAIN/CULVERT
- - - - - PROPOSED DRAINAGE DITCH

SCALE: 1" = 40'	DATE: 5-10-22	DESIGN: KAN	DRAWN: KAN	CHECKED: RC								
<table border="1" style="width: 100%; border-collapse: collapse;"> <thead> <tr> <th style="width: 10%;">REVISIONS</th> <th style="width: 90%;">DESCRIPTION</th> </tr> </thead> <tbody> <tr> <td>DATE</td> <td></td> </tr> </tbody> </table>					REVISIONS	DESCRIPTION	DATE					
REVISIONS	DESCRIPTION											
DATE												
<table border="1" style="width: 100%; border-collapse: collapse;"> <tr> <td colspan="2" style="text-align: center;">PLAN AND PROFILE ROAD 4</td> </tr> <tr> <td colspan="2" style="text-align: center;">OSPREY RANCH</td> </tr> <tr> <td colspan="2" style="text-align: center;">UT-158</td> </tr> <tr> <td colspan="2" style="text-align: center;">EDEN, WEBER, UTAH</td> </tr> </table>					PLAN AND PROFILE ROAD 4		OSPREY RANCH		UT-158		EDEN, WEBER, UTAH	
PLAN AND PROFILE ROAD 4												
OSPREY RANCH												
UT-158												
EDEN, WEBER, UTAH												
CIVIL • LAND PLANNING MUNICIPAL • LAND SURVEYING 5150 SOUTH 375 EAST OGDEN, UT OFFICE: 801-476-0202 FAX: 801-476-0066												
PP12												

PLAN 1201 - LEWIS, HOWES, 2105 - OSPREY RANCH, UTAH - OSPREY RANCH, UTAH - OSPREY PLAN PROFILE SHEETS PHASE 1 - RECOVER, RECOVER.DWG

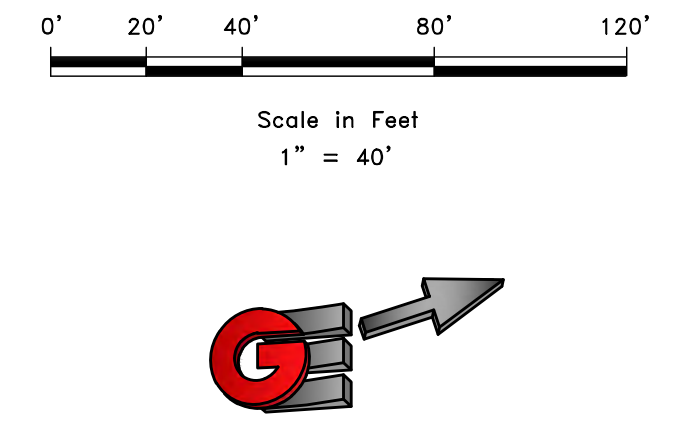
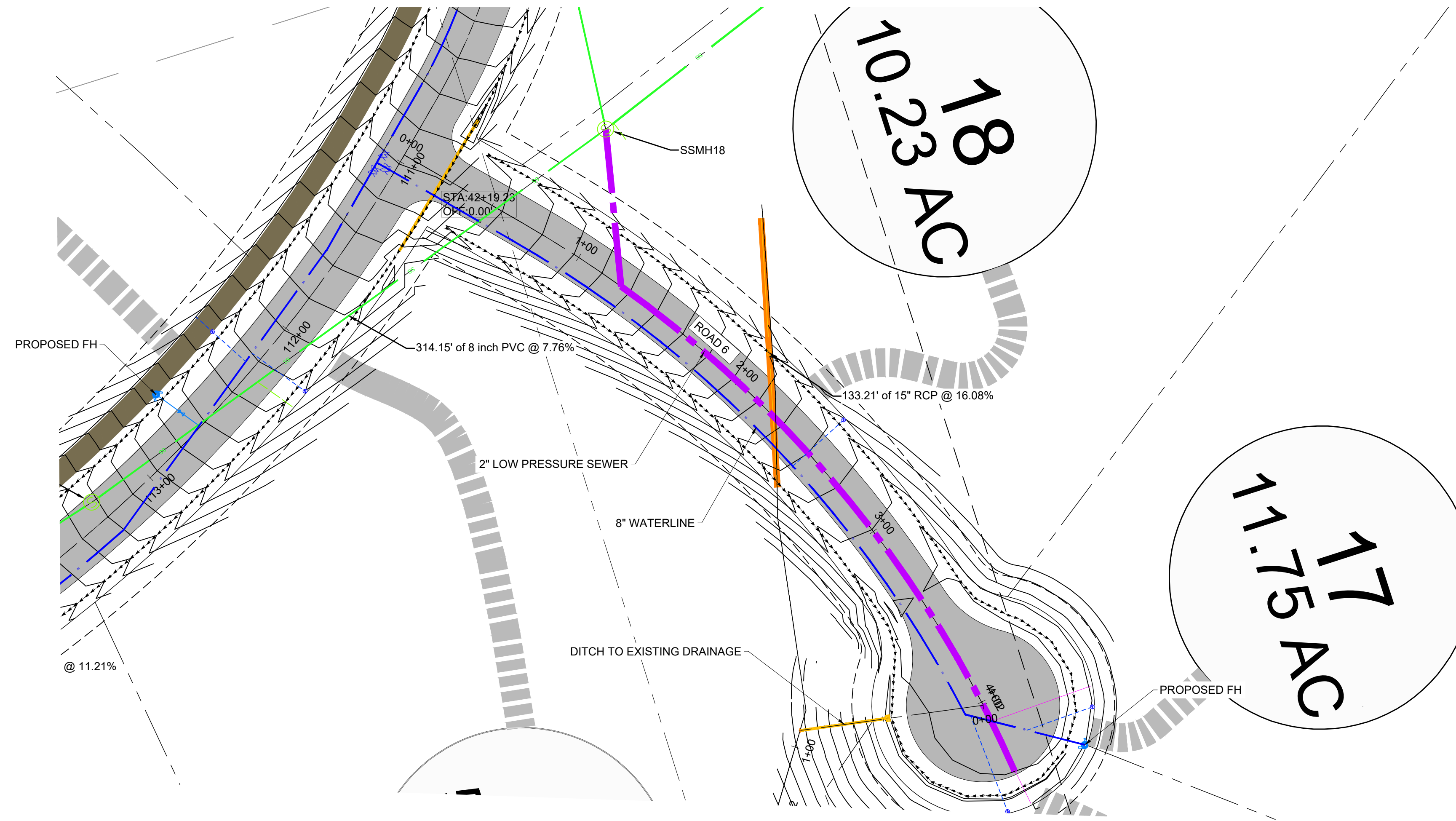

- PROPOSED WATER - C900 DR14
- PROPOSED LOW PRESSURE SEWER SDR -11
- PROPOSED GRAVITY SEWER - SDR-35
- PROPOSED STORM DRAIN/CULVERT
- PROPOSED DRAINAGE DITCH

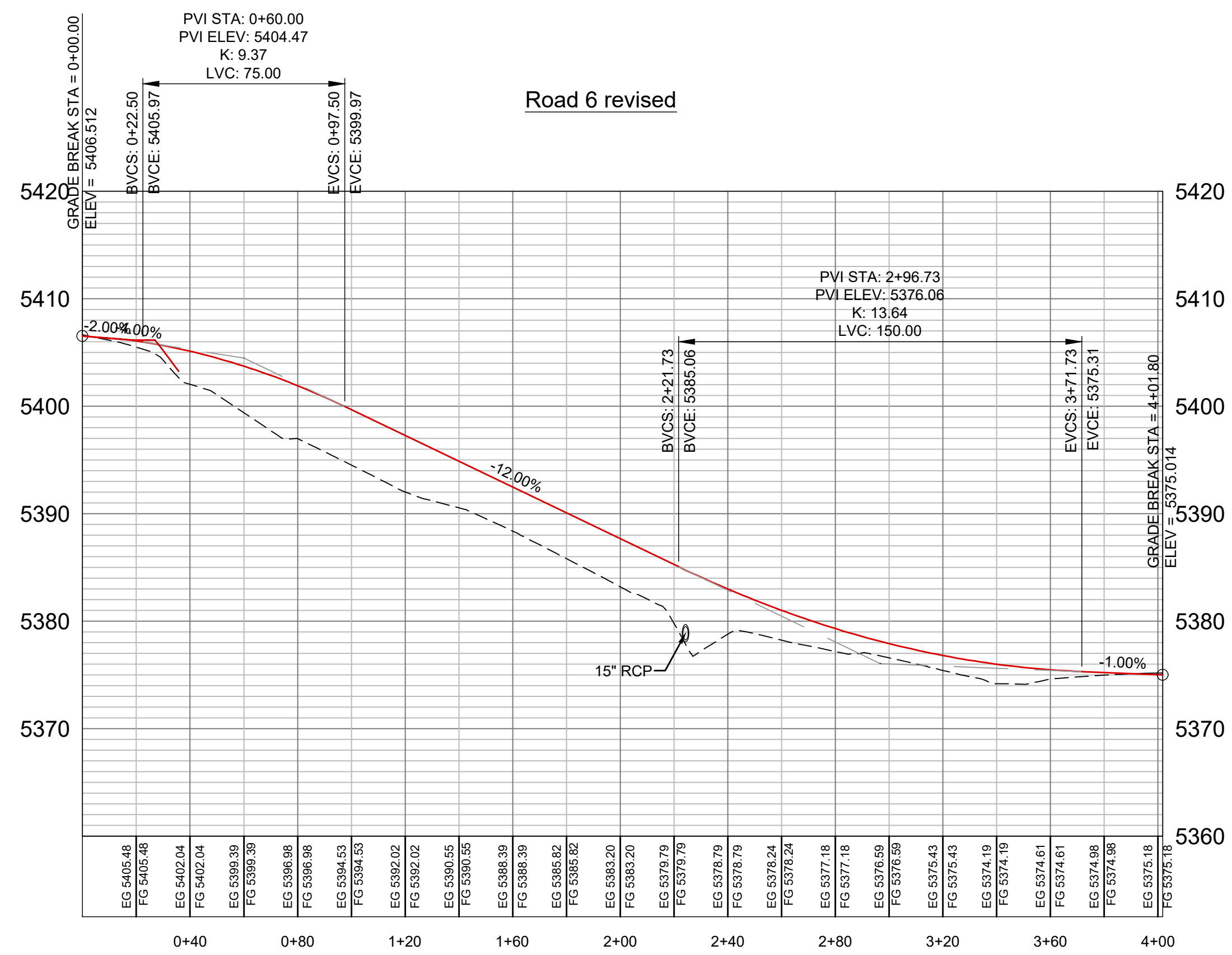

PLAN AND PROFILE ROAD 6  
OSPREY RANCH  
UT-158  
EDEN, WEBER, UTAH

**GARDNER ENGINEERING**  
CIVIL • LAND PLANNING  
MUNICIPAL • LAND SURVEYING  
5150 SOUTH 375 EAST OGDEN, UT  
OFFICE: 801.476.0202 FAX: 801.476.0066

REVISIONS	DATE	DESCRIPTION

SCALE: 1" = 40'  
DATE: 5-19-22  
DESIGN: KAN  
DRAWN: KAN  
CHECKED: RC



PLAN AND PROFILE ROAD 2  
 OSPREY RANCH  
 EDEN, WEBER, UTAH

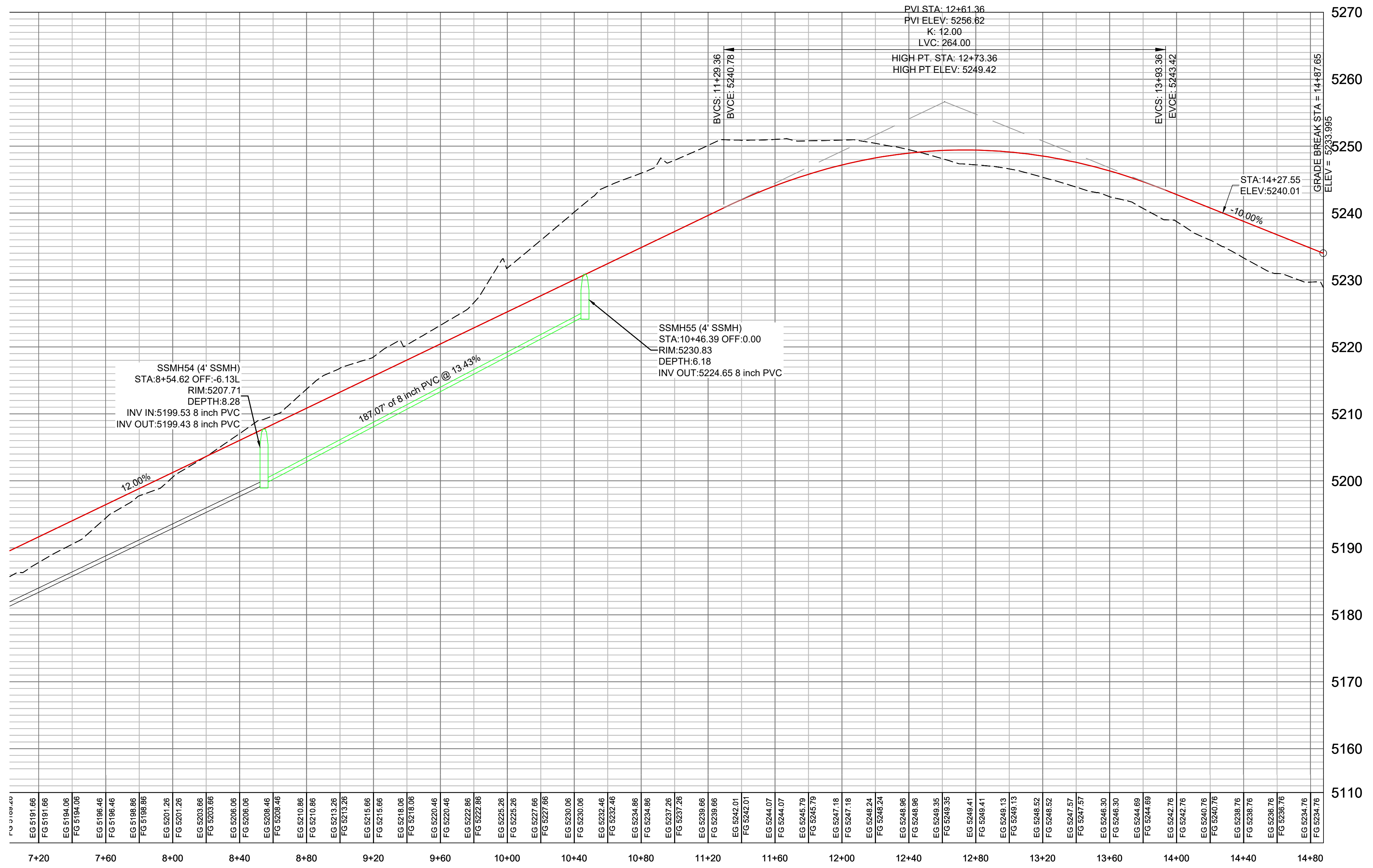
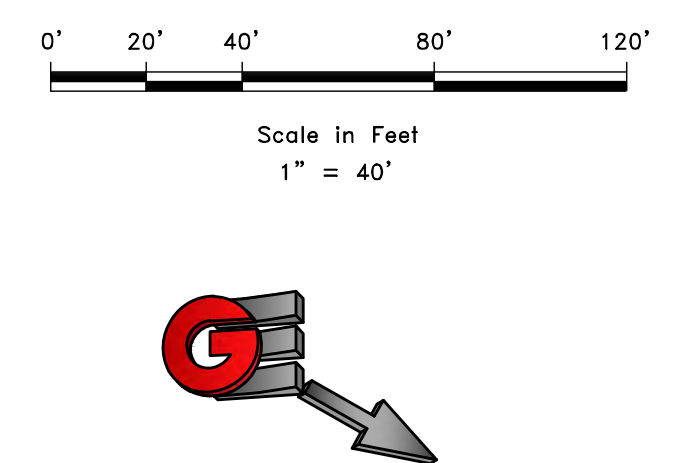
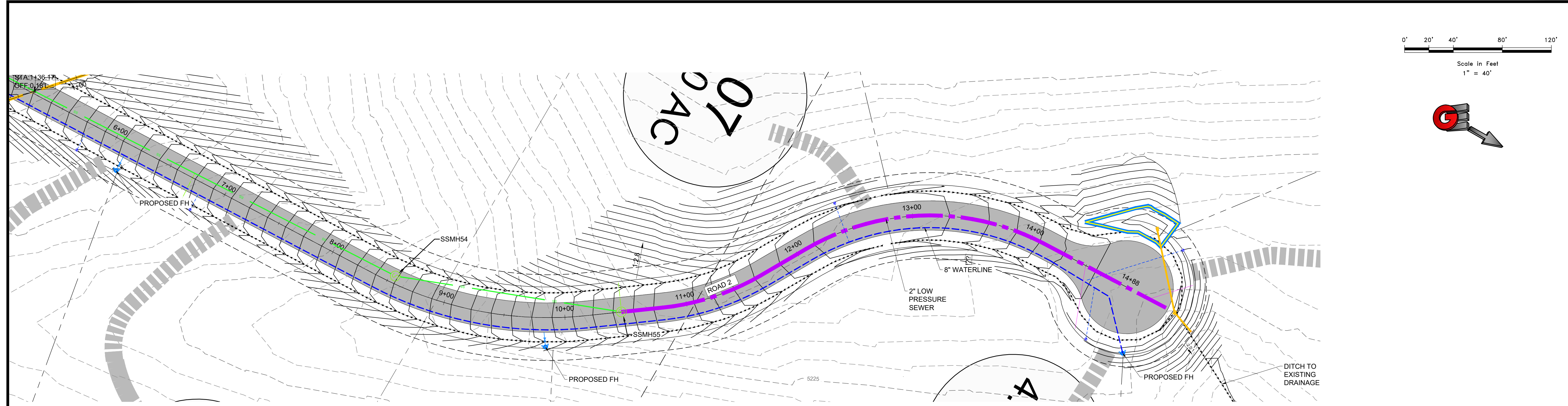

- LOCATION MAP
- PROPOSED WATER - C900 DR14
  - PROPOSED LOW PRESSURE SEWER SDR - 11
  - PROPOSED GRAVITY SEWER - SDR-35
  - PROPOSED STORM DRAIN/CULVERT
  - PROPOSED DRAINAGE DITCH

SCALE: 1" = 40' DATE: 5-10-22 DESIGN: KAN DRAWN: KAN CHECKED: RC	REVISIONS <table border="1" style="width: 100%; border-collapse: collapse;"> <thead> <tr> <th>DATE</th> <th>DESCRIPTION</th> </tr> </thead> <tbody> <tr> <td> </td> <td> </td> </tr> </tbody> </table>	DATE	DESCRIPTION			<p><b>PLAN AND PROFILE ROAD 2</b></p> <p><b>OSPREY RANCH</b></p> <p><b>UT-158</b></p> <p><b>EDEN, WEBER, UTAH</b></p>
DATE	DESCRIPTION					
<p><b>GARDNER ENGINEERING</b>          CIVIL • LAND PLANNING          MUNICIPAL • LAND SURVEYING          51150 SOUTH 375 EAST OGDEN, UT          OFFICE: 801-476-0202 FAX: 801-476-0066</p>						
<p>PP15</p>						





PLAN AND PROFILE SEWER OSPREY RANCH UT-158

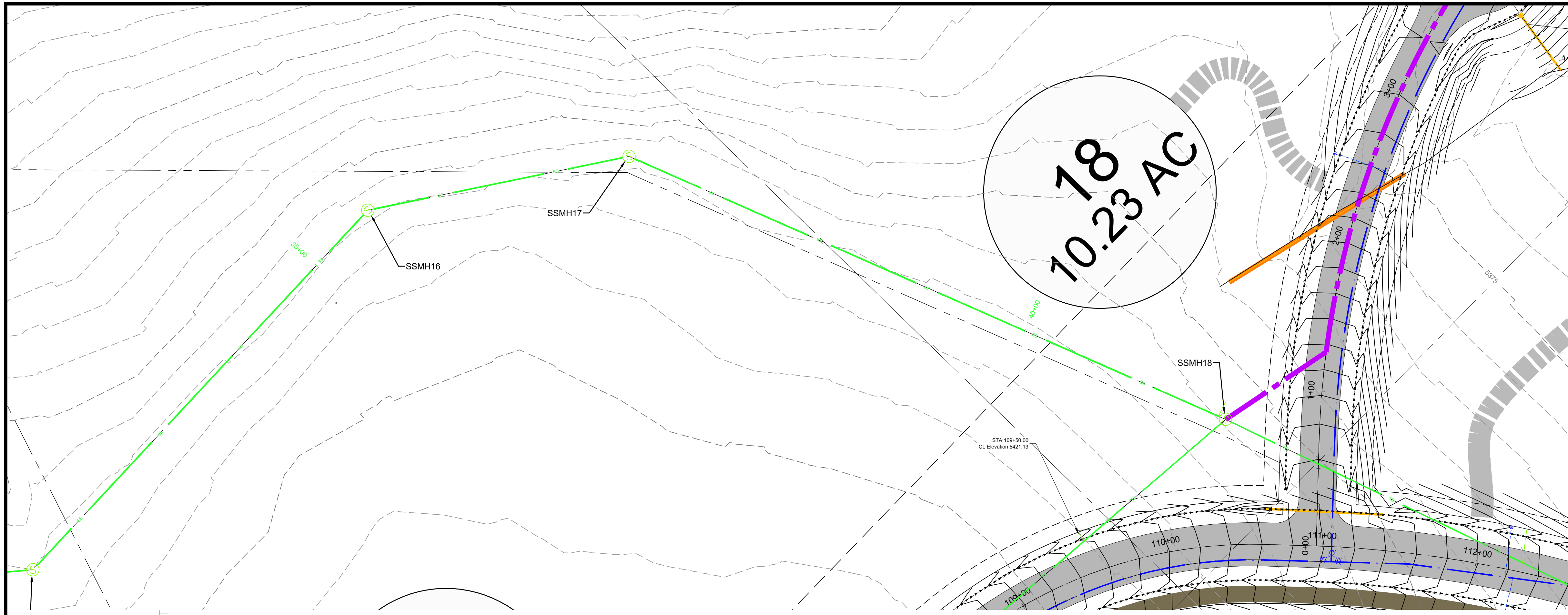

LOCATION MAP

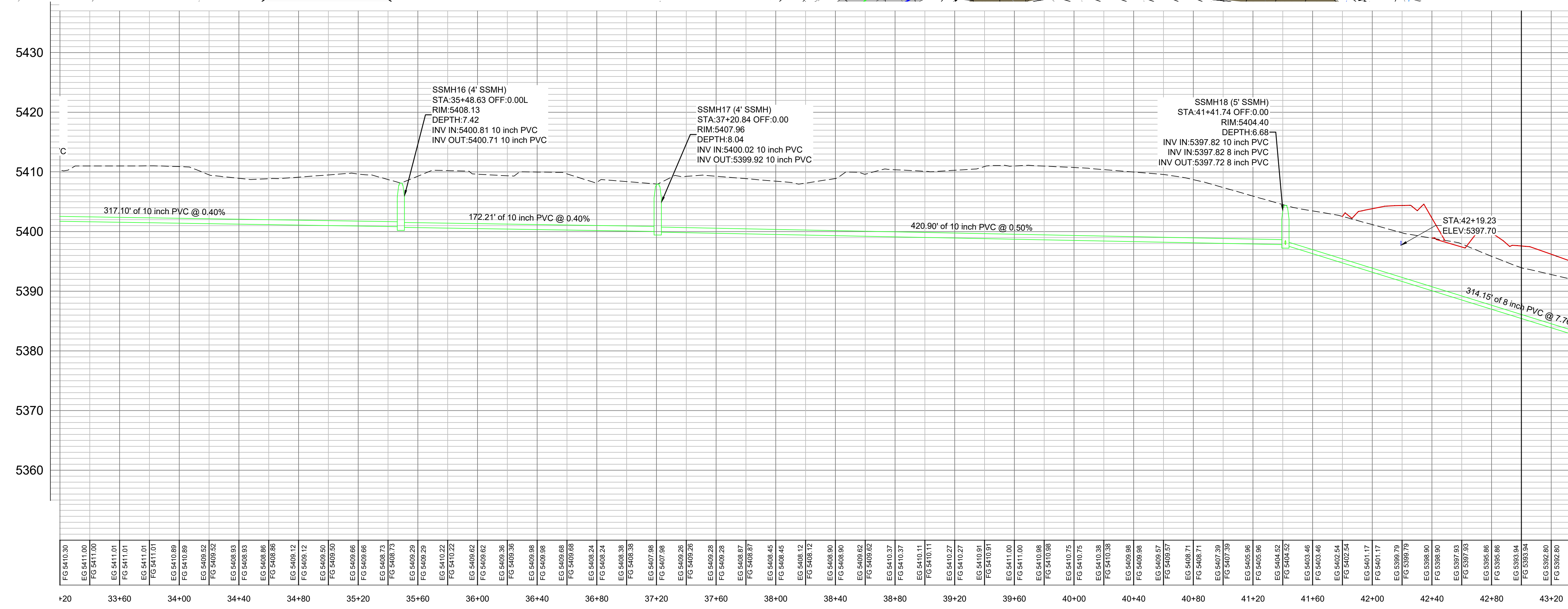

SCALE	1" = 40'
DATE	5-10-22
DESIGN	KAN
DRAWN	KAN
CHECKED	RC

REVISIONS	DESCRIPTION
DATE	

DWG:	
------	--

PLAN AND PROFILE SEWER  
OSPREY RANCH  
UT-158  
EDEN, WEBER, UTAH

**GARDNER ENGINEERING**  
CIVIL • LAND PLANNING  
MUNICIPAL • LAND SURVEYING  
5150 SOUTH 375 EAST OGDEN, UT  
OFFICE: 801-476-0202 FAX: 801-476-0066

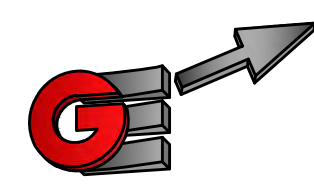
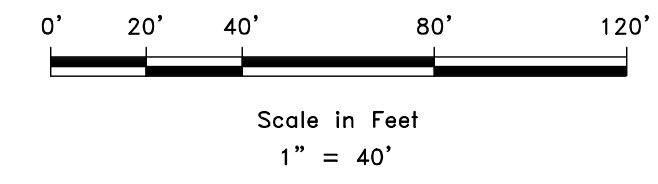
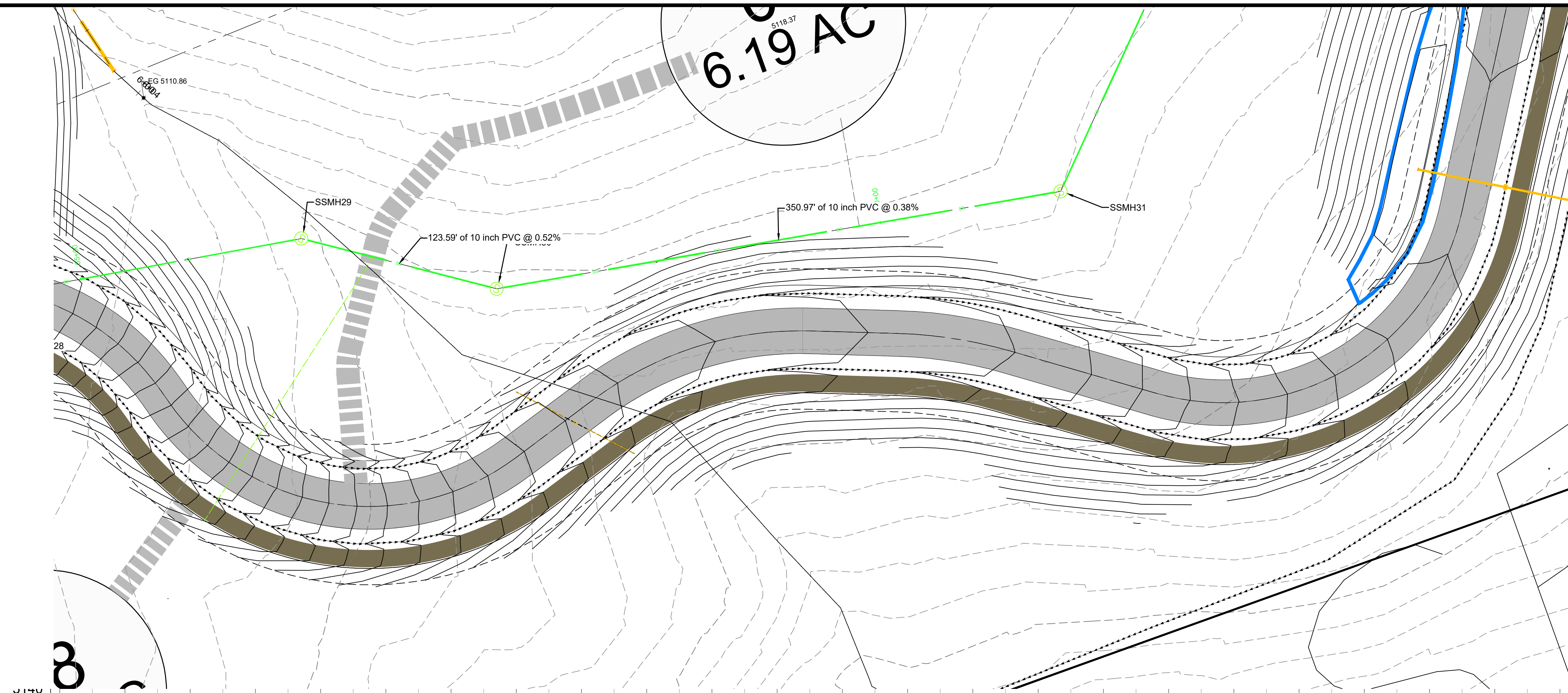

REVISIONS	DATE	DESCRIPTION

SCALE: 1" = 40'
DATE: 5-10-22
DESIGN: KAN
DRAWN: KAN
CHECKED: RC

PLAN AND PROFILE SEWER  
OSPREY RANCH  
UT-158  
EDEN, WEBER, UTAH

**GARDNER ENGINEERING**  
CIVIL • LAND PLANNING  
MUNICIPAL • LAND SURVEYING  
51150 SOUTH 375 EAST OGDEN, UT  
OFFICE: 801-476-0202 FAX: 801-476-0066

PLAN AND PROFILE SEWER

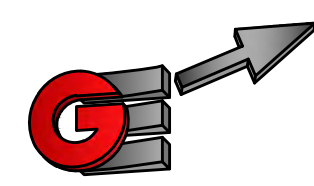
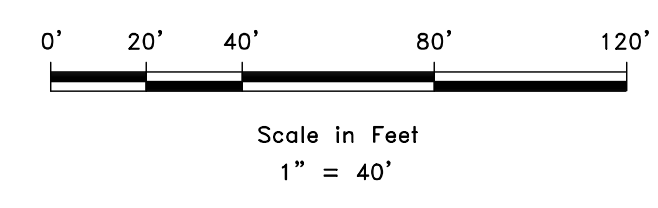
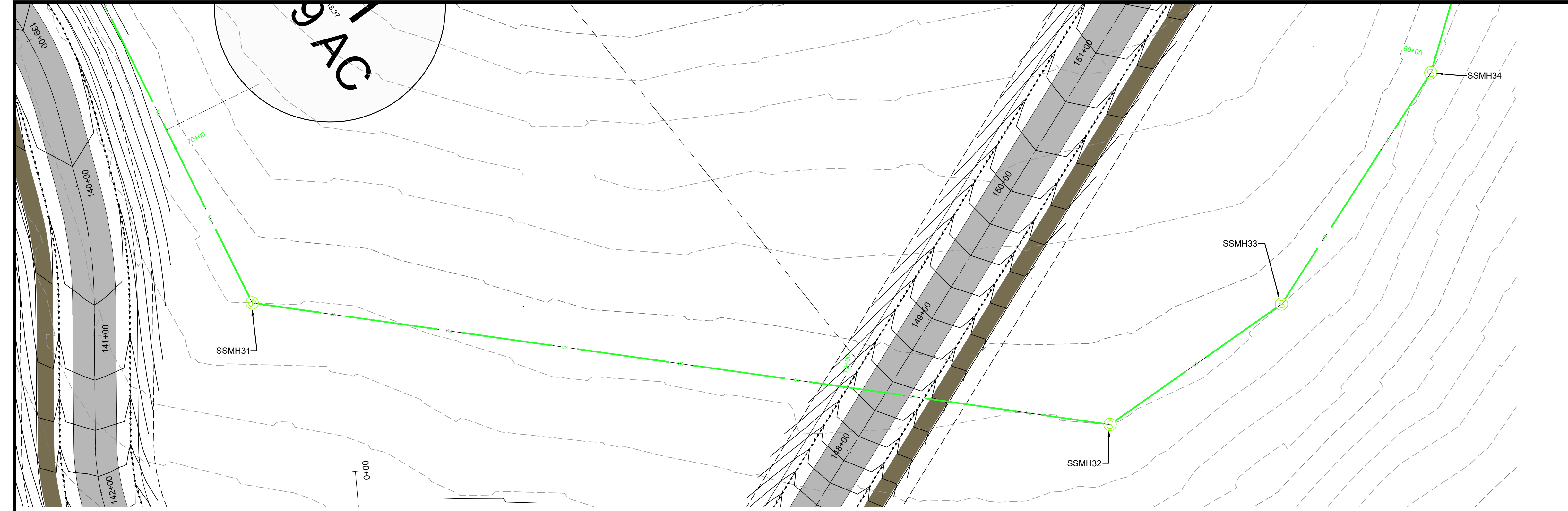

LOCATION MAP

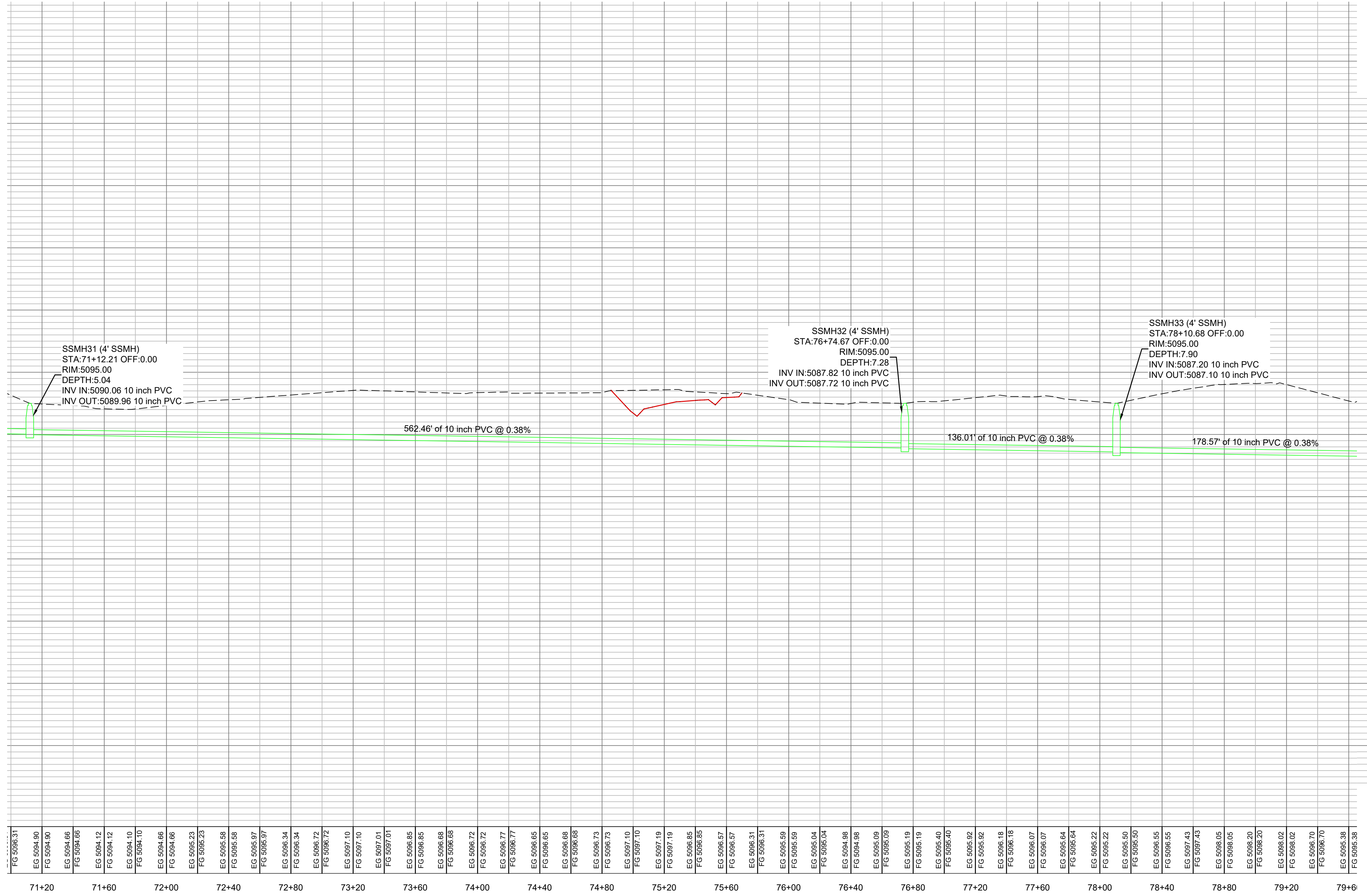

FG 5096.31	EG 5094.90	FG 5094.90	EG 5094.06	FG 5094.06	EG 5094.12	FG 5094.12	EG 5094.10	FG 5094.06	EG 5095.23	FG 5095.23	EG 5095.58	FG 5095.58	EG 5095.34	FG 5095.34	EG 5096.72	FG 5096.72	EG 5097.10	FG 5097.10	EG 5097.01	FG 5097.01	EG 5096.85	FG 5096.85	EG 5096.68	FG 5096.68	EG 5096.72	FG 5096.72	EG 5096.77	FG 5096.77	EG 5096.65	FG 5096.65	EG 5096.68	FG 5096.68	EG 5097.10	FG 5097.10	EG 5097.19	FG 5097.19	EG 5096.85	FG 5096.85	EG 5096.57	FG 5096.57	EG 5096.31	FG 5096.31	EG 5095.59	FG 5095.59	EG 5095.04	FG 5095.04	EG 5094.98	FG 5094.98	EG 5095.09	FG 5095.09	EG 5095.09	FG 5095.09	EG 5095.19	FG 5095.19	EG 5095.40	FG 5095.40	EG 5095.92	FG 5095.92	EG 5096.18	FG 5096.18	EG 5096.07	FG 5096.07	EG 5095.22	FG 5095.22	EG 5095.55	FG 5095.55	EG 5096.43	FG 5096.43	EG 5096.05	FG 5096.05	EG 5096.20	FG 5096.20	EG 5096.02	FG 5096.02	EG 5096.70	FG 5096.70	EG 5095.38	FG 5095.38
71+20	71+60	72+00	72+40	72+80	73+20	73+60	74+00	74+40	74+80	75+20	75+60	76+00	76+40	76+80	77+20	77+60	78+00	78+40	78+80	79+20	79+60																																																									

PLAN AND PROFILE SEWER  
 OSPREY RANCH  
 UT-158  
 EDEN, WEBER, UTAH

**GARDNER ENGINEERING**  
 CIVIL • LAND PLANNING  
 MUNICIPAL • LAND SURVEYING  
 51150 SOUTH 375 EAST OGDEN, UT  
 OFFICE: 801-476-0202 FAX: 801-476-0066

REVISIONS	DATE	DESCRIPTION

SCALE: 1" = 40'	DATE: 5-19-22	DESIGN: KAN	DRAWN: KAN	CHECKED: RC
-----------------	---------------	-------------	------------	-------------

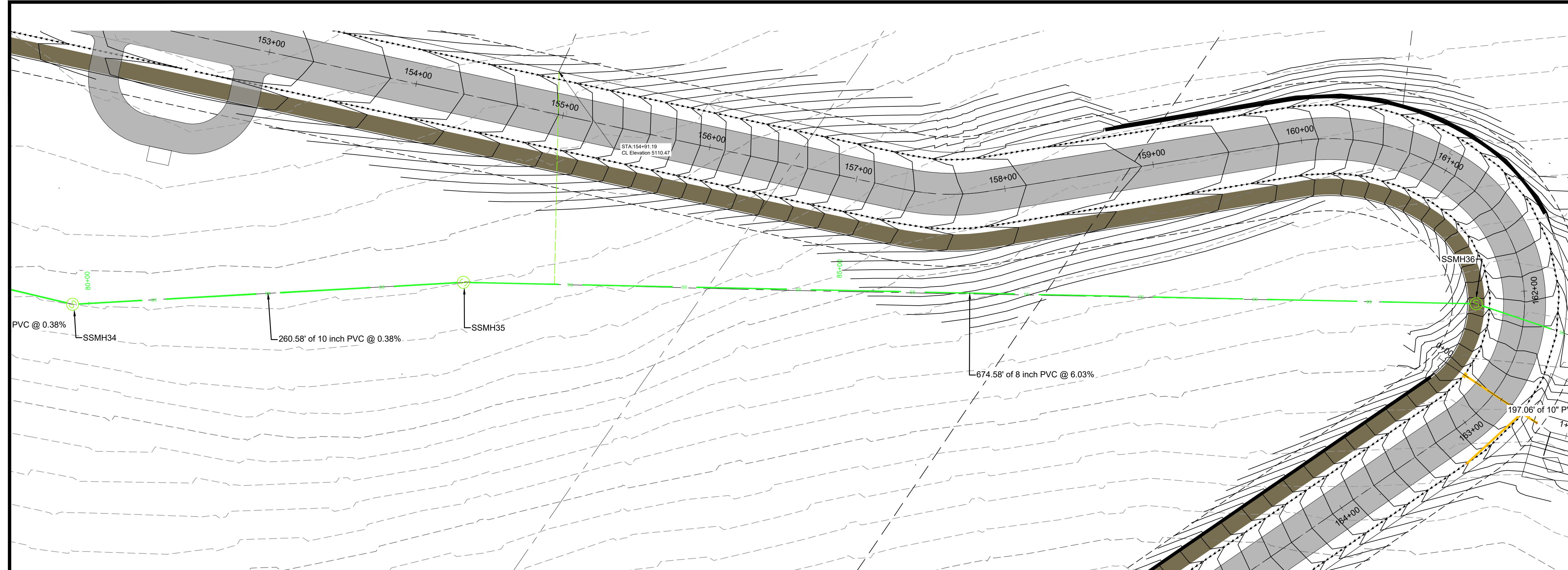

PLAN AND PROFILE SEWER  
 OSPREY RANCH  
 EDEN, WEBER, UTAH  
 DWG: PS5

SCALE	1" = 40'
DATE	5-10-22
DESIGN	KAN
DRAWN	KAN
CHECKED	RC

REVISIONS	DATE	DESCRIPTION

DWG:	
------	--

**PLAN AND PROFILE SEWER**  
**OSPREY RANCH**  
**UT-158**  
**EDEN, WEBER, UTAH**

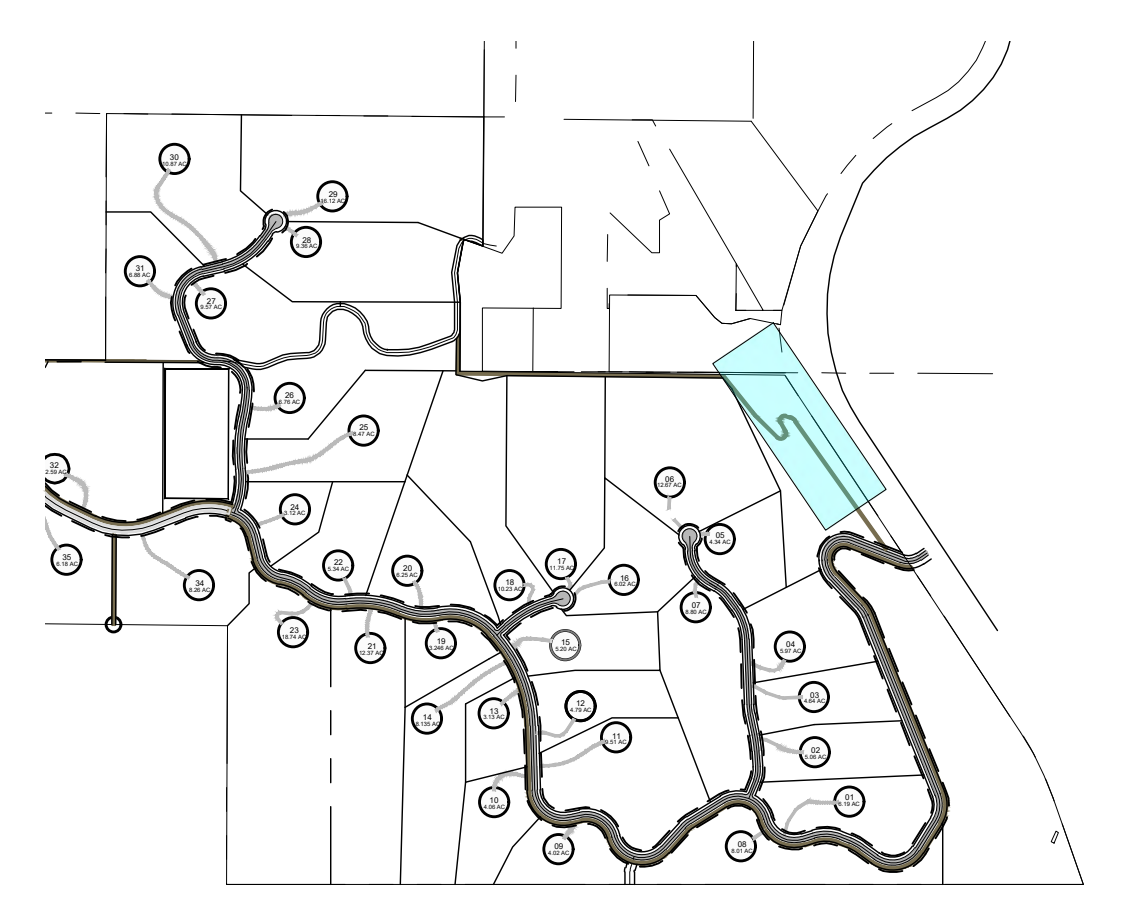
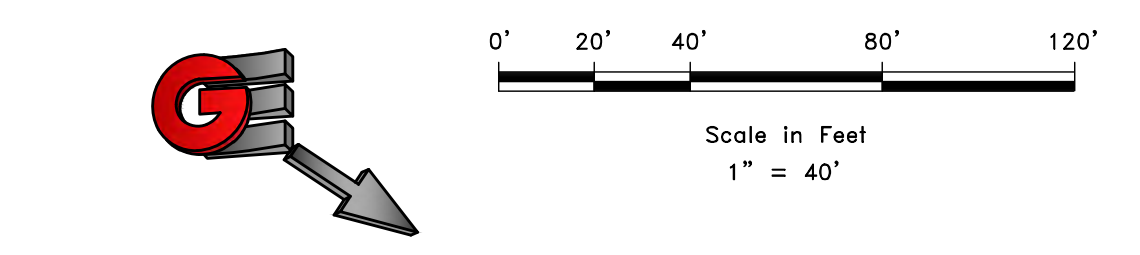
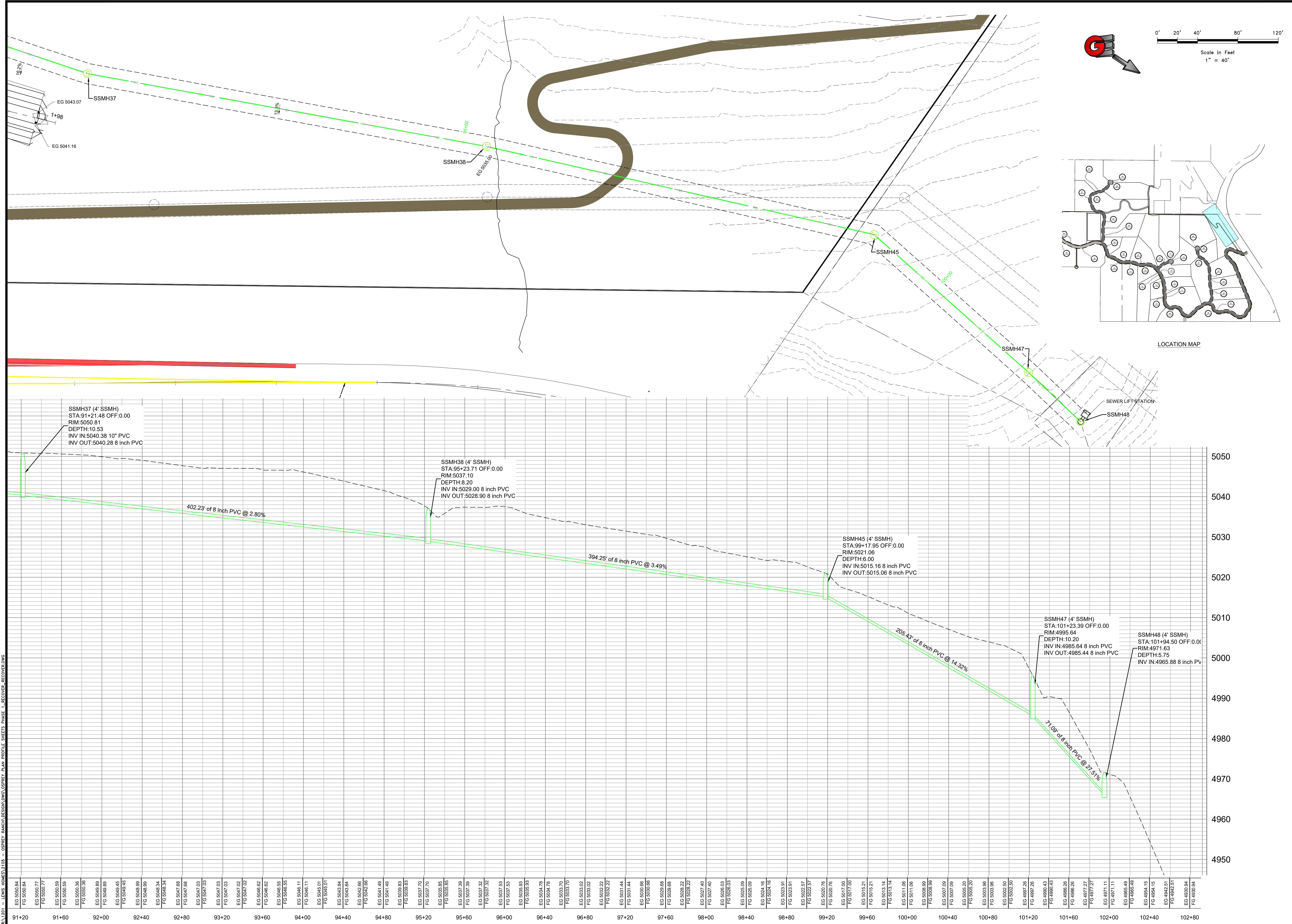

11/20/21 - LEWIS, HOWES & SONS - OSPREY RANCH (ES&S) (DWG) OSPREY PLAN PROFILE SHEETS PHASE 1 - RECORD RECOVERING

SCALE	1" = 40'
DATE	5/10/22
DESIGN	KAN
DRAWN	KAN
CHECKED	RC

REVISIONS	DATE	DESCRIPTION

DWG:	
------	--

**PLAN AND PROFILE SEWER**  
**OSPREY RANCH**  
**UT-158**  
**EDEN, WEBER, UTAH**

# DETAIL ALTITUDE VALVE

BILL OF MATERIALS		NOTES
1	2	6" DIP SPOOL 4'-0" LENGTH FLGXPE
2	2	6" TEE FLGXFLG
3	2	6" GATE VALVE W/ HAND WHEEL
4	1	6" ALTITUDE VALVE
5	1	6" FLANGED COUPLING ADAPTER
6	1	6" DIP SPOOL 9" LENGTH FLGXPE
7	2	6" BLIND FLANGE
8	-	2" BRASS PIPE ELBOWS FOR BYPASS
9	1	2" BRASS BODY GATE VALVE
10	1	2" 3 PIECE UNION
11	2	2" BRASS BODY BUTTERFLY VALVE
12	2	6" FIELD FLANGE FOR DIP
13	2	1/4" THICK STEEL THRUST PLATE
14	2	PRE-CORED HOLES 8"Ø
15	-	1" CTS SDR9 HDPE NSF61 SENSING LINE
16	1	PRE-CORED HOLE 4"Ø
17	1	6' X 9' X 7' TALL PRECAST CONCRETE VAULT
18	1	4" DRAIN PVC PIPE TO DAYLIGHT
19	1	A-1180 D&L MANHOLE RING AND COVER
20	2	1/2" SMOOTH NOSE TAP
21	2	1/4" (1-100) PSI DIGITAL PRESSURE SENSOR
22	2	3/4" BRASS PIPING AND ISOLATION VALVE
23	5	ADJUSTABLE PIPE STAND
24	2	6" X 8" REDUCER
25	2	1" S.S. THREADED NIPPLE THROUGH WALL AND RNC TO VALVE/METER.

\*IMPRINTED STAINLESS STEEL TAG, 1/8" THICK, 2"x4" 8" LETTERING HEIGHT. ATTACHED TO VALVE W/SS. CHAIN (WIRE LINK OR BEADED TYPE)

"EMERGENCY BYPASS

"1. FULLY OPEN GATE VALVES  
 "2. OPEN B.V. ENOUGH FOR 2 PSI DROP ON UPSTREAM GAUGE.  
 "3. FULLY CLOSE GATE VALVES WHEN DONE"

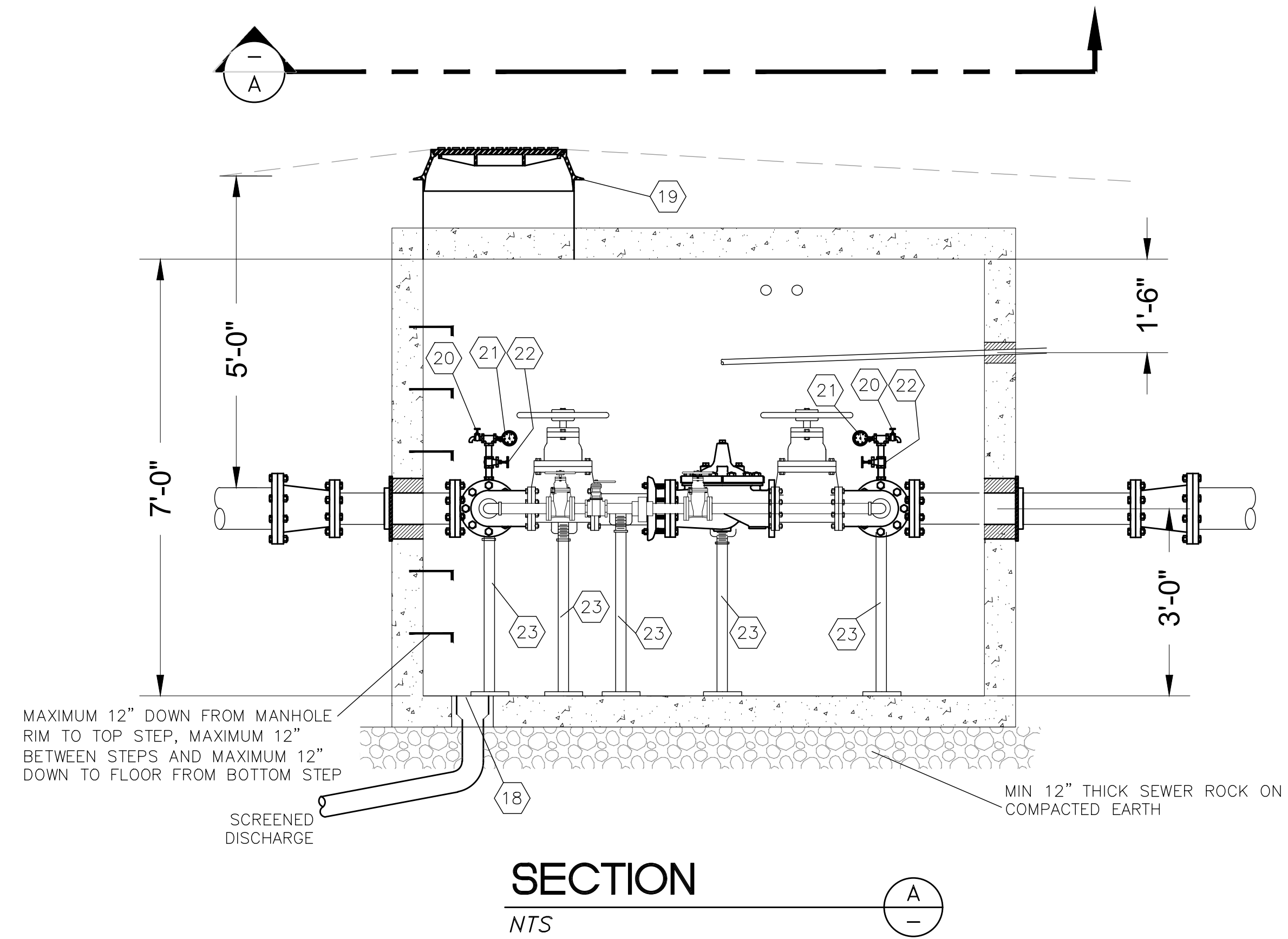
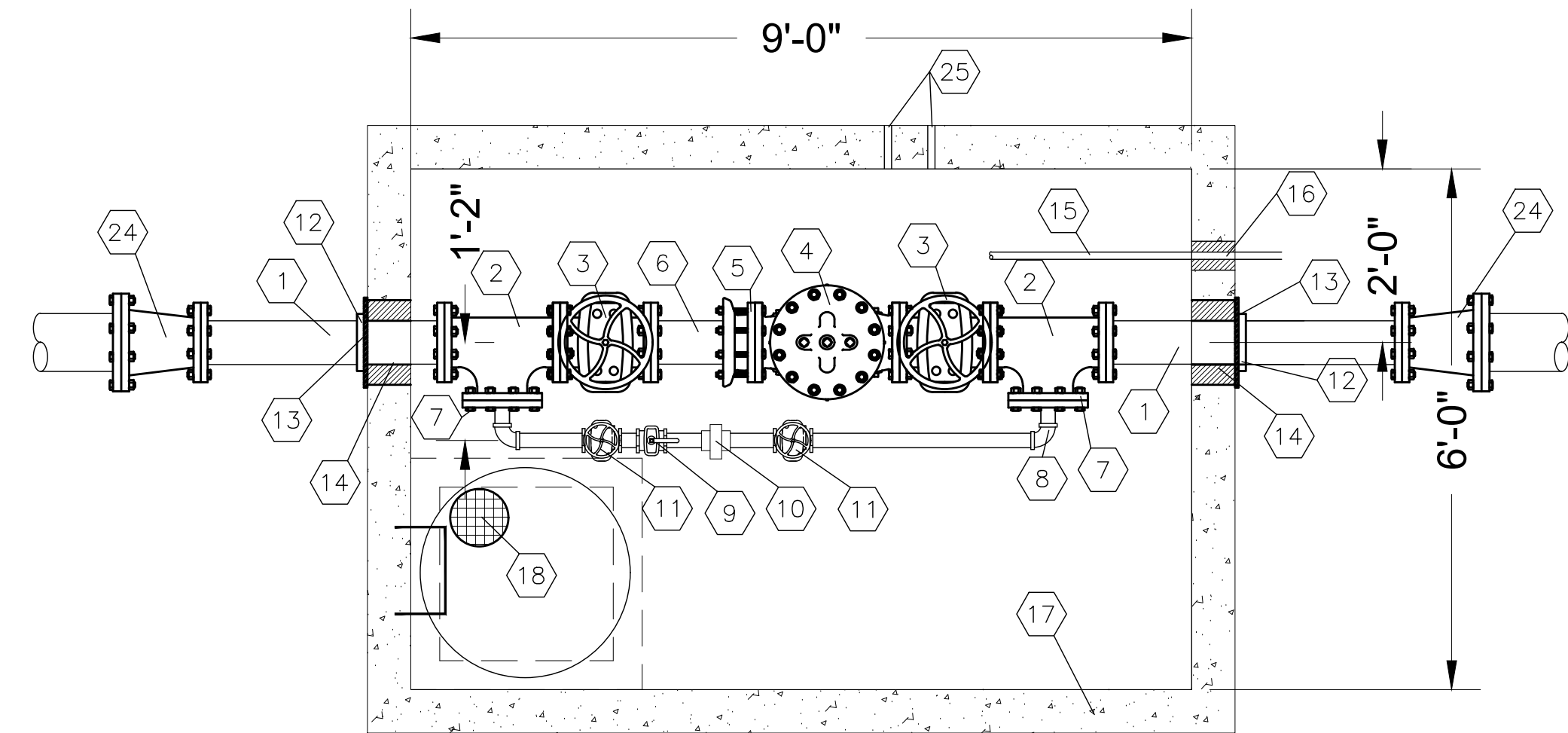
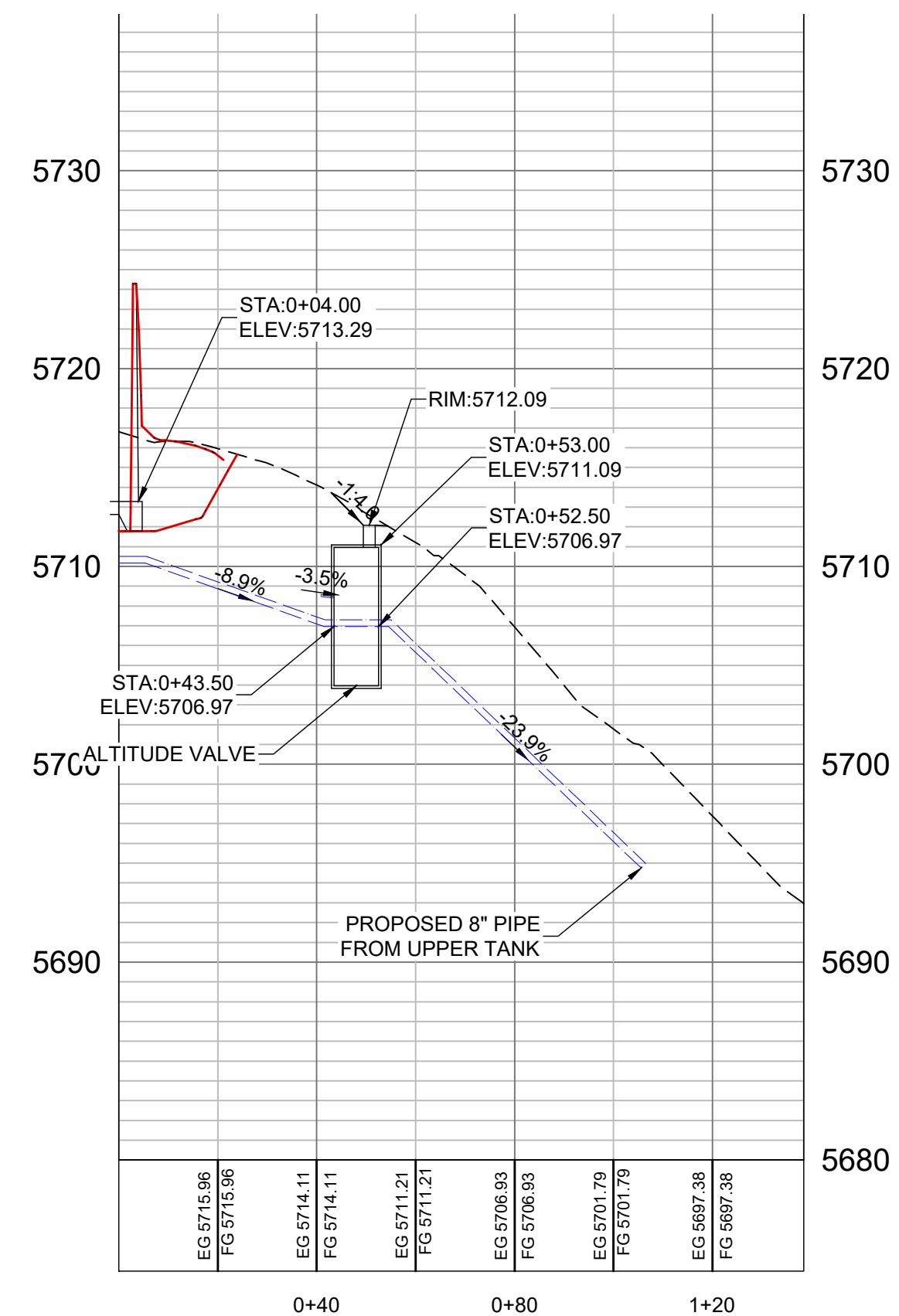

REVISIONS	DESCRIPTION
DATE	

SCALE	DATE	DESIGN	DRAWN	CHECKED
*****	01-21-22	KAN	KAN	PC

DETAIL ALTITUDE VALVE  
 OSPREY RANCH  
 1800 N HYW 158  
 EDEN, WEBER, UTAH

**GARDNER ENGINEERING**  
 CIVIL-LAND PLANNING  
 MUNICIPAL-LAND SURVEYING  
 5150 SOUTH 375 EAST OGDEN, UT  
 OFFICE: 801.476.0202 FAX: 801.476.0066

DT3

# WATER DETAILS

**1 THRUST BLOCK DETAIL**  
NTS

APPLIES TO ALL PRESSURE PIPE

ADJUST WATER VALVE BOX TO GRADE FOLLOWING FINAL SURFACE PREP. W/CONCRETE COLLAR. COLLAR TO BE HELD DOWN 1/4" BELOW TOP OF NEW ASPHALT IF IN ROADWAY.

**2 TYPICAL VALVE DETAIL**  
NTS

NOTES:  
1. VALVE BOX, RISER AND LID MUST COME FROM THE SAME MFR. BE INTENDED FOR USE TOGETHER AND SHALL BE WITHIN PUBLISHED DIMENSIONS TO BRANDES.  
2. IF LOCATED IN ROADWAY W/ SPEED LIMIT OF 40 MPH OR GREATER, LID SHALL BE HEAVY AND EXTRA DEEP.  
3. VALVES MUST BE INSTALLED ON EACH SIDE OF TEES AND CROSSES, UNLESS THERE IS A VALVE WITHIN 200 FEET OF SAID FITTINGS.

**TABLE OF BEARING AREAS IN SQ. FT. FOR CONCRETE THRUST BLOCKING**

SIZE	BENDS		TEES		CROSSES		VALVE BOXES	
	90°	45°	22.5°	11.25°	90°	45°	22.5°	11.25°
3	1.0	0.6	0.5	0	0.7	0.5	0.7	0.7
4	1.8	1.0	0.8	0	1.1	0.8	1.1	1.1
6	4.0	2.2	1.1	0	2.8	0.7	2.8	2.8
8	7.1	3.8	2.0	0	5.0	2.4	5.0	5.0
10	11.1	6.0	3.0	1.5	7.8	4.5	7.8	7.8
12	16.0	8.8	4.4	2.2	11.3	7.3	11.3	11.3
14	21.7	11.8	6.0	3.0	15.4	11.0	15.4	15.4
15	28.5	13.5	7.0	3.5	17.0	12.0	17.0	17.0
18	38.4	18.3	9.0	4.0	23.0	16.0	23.0	23.0
18	38.0	18.4	10.0	5.0	25.4	18.4	25.4	25.4
20	44.2	24.0	12.2	6.1	27.4	21.4	27.4	27.4
21	48.0	26.5	13.5	6.8	34.8	24.8	34.8	34.8
22	54.0	29.0	14.8	7.4	38.0	28.0	38.0	38.0
24	64.0	34.5	17.7	8.8	45.0	33.0	45.0	45.0
30	100.0	54.0	27.4	13.8	71.0	51.0	71.0	71.0
36	144.0	78.0	40.0	20.0	100.0	70.0	100.0	100.0

AREAS GIVEN IN TABLE ARE BASED UPON AN INTERNAL STATIC PRESSURE OF 100 P.S.I. AND A SOIL BEARING CAPACITY OF 1000 LBS PER SQ. FT. BEARING AREAS FOR ANY PRESSURE AND SOIL BEARING CAPACITY MAY BE OBTAINED BY MULTIPLYING THE TABULATED VALUES BY A CORRECTION FACTOR "F".

F = ACTUAL SPECIFIED TEST PRESSURE IN HUNDREDS OF LBS/SQ. IN.  
ACTUAL SOIL BEARING CAPACITY IN THOUSANDS OF LBS.

EXAMPLE: TO FIND BEARING AREA FOR 8" 90° BEND WITH A STATIC INTERNAL PRESSURE OF 150 P.S.I. AND WITH A SOIL BEARING CAPACITY OF 3000 LBS. PER SQ. FT.  
F = 1.5 / 100 = 0.015  
8" 90° BEND = 1.1 SQ. FT. (FROM TABLE)  
1.1 SQ. FT. x 0.015 = 0.0165 SQ. FT. (CORRECTED LONG BY 2 FT. HIGH)

**3A TYPICAL TRENCH SECTION**  
NTS

CONTRACTOR IS RESPONSIBLE TO MEET TRENCH RESTORATION STANDARDS OF THE ENTITY OWNING THE ROADWAY. RESTORE THE ROADWAY TO SAID STANDARDS AND SHALL BE SOLELY RESPONSIBLE FOR ALL ROADWAY PERMITS AND/OR FEES.

NOTE:  
1. WATER & SEWER LINES SHALL BE INSTALLED A MINIMUM OF 10" HORIZONTAL FEET FROM EACH OTHER.  
2. WHERE A WATER LINE AND A SEWER LINE MUST CROSS, THE WATER LINE SHALL BE AT LEAST 10" ABOVE THE SEWER LINE.  
3. SEPARATION DISTANCES ARE TO BE MEASURED ACROSS TO CENTER.  
4. WATER LINES SHALL NOT BE INSTALLED IN THE SAME TRENCH WITH EITHER SEWER OR SECONDARY PIPES.  
5. IF THESE STANDARDS CANNOT BE MET AN EXCEPTION TO THE STANDARD MAY BE POSSIBLE. THE ENTITY SEEKING THE EXCEPTION SHALL INITIATE AND PURSUE A REQUEST FOR A SEPARATION EXCEPTION WITH THE STATE DIVISION OF DRINKING WATER, IN ACCORDANCE WITH RSD-009-07 OF THE STATE OF UTAH ADMINISTRATIVE RULES.

**4 TYPICAL WATER CONNECTION/RE-CONNECTION**  
NTS

**5 FIRE HYDRANT DETAIL**  
NTS

NOTE:  
HYDRANT DRAINS SHALL NOT BE CONNECTED TO OR LOCATED WITHIN 10 FEET OF SANITARY SEWERS. WHERE POSSIBLE, HYDRANT DRAINS SHALL NOT BE LOCATED WITHIN 10 FEET OF STORM DRAINS.

**6 COMBINATION AIR/VAC VALVE DETAILS**  
NTS

NOTES:  
1. LOCATE STANDPIPE WELL OUTSIDE TRAVELED ROADWAY OR AS DIRECTED BY THE ENGINEER.

**AIR/VAC VALVE DETAIL**  
NTS

ELBOW AT VALVE. TRANSITION TO POLY PIPE TO TOP OF VENT. DIAMETER DETERMINED BY AIR VALVE SIZE.  
PROVIDE MIN 4" DIA CONCRETE MANHOLE SECTION WITH STEPS 12" APART.  
AIR/VAC OR VALVE MATIC 1" COMBINATION AIR/VAC RELEASE VALVE OR APPROVED EQUAL. LOCATE AT HIGH POINT OF PIPELINE. SPECIFY AN OPERATING PRESSURE BELOW 150# WHEN ORDERING.  
GATE OR BALL VALVE. ALL PIPE AND FITTINGS BETWEEN MAINLINE AND AIR VALVE SHALL BE BRASS.  
1 CUBIC YARD OF FREE DRAINING GRAVEL.  
ROMAC 202NS SERVICE SADDLE W/ DOUBLE STRAPS OR EQUAL.

**8A PRV STATION**  
NTS

SEE DETAIL 8B ON SHEET 7 FOR BILL OF MATERIALS

**8B PRV STATION**  
NTS

NOTE: PREP ALL GROUND STEEL PIPE W/ BLUE DANGEROUS RESISTANT PAINT.

**AIR-VAC ASSEMBLY**  
NTS

**VENT SHROUD DETAIL**  
NTS

**BILL OF MATERIALS**

NO.	QTY	DESCRIPTION	6" LINE	8" LINE	10" LINE	NOTES	
1	1	DIP OR FIVE MANHOLE	6"	8"	10"		
2	2	REDUCER MANHOLE	6"x4"	8"x6"	10"x8"	USE JOINT RETAINER GLANDS	
3	1	DIP SHROUD 5'-0" LENGTH FLOPPE	4"	6"	8"		
4	2	FIELD FLANGE FOR DIP	4"	6"	8"		
5	2	1/4" THICK STEEL THRUST PLATE	10"x10"	10"x10"	10"x10"	SO. W/ # 4 CUT OUT	
6	2	PRE-CORR HOLES	10" x 4"	12" x 6"	14" x 8"	SEAL WITH NON-SHRINK GROUT	
7	2	TEE FLANGERS	4"x4"x4"	6"x6"x6"	8"x8"x8"		
8	2	1/4" (1-200) PSI LIQUID FILLED PRESSURE GAUGE	6"	6"	8"	SUPPLY WITH BRASS STOP COCK	
9	2	RESILIENT SEAT GATE VALVE W/ VALVE BOX	6"	6"	8"		
10	1	PRESSURE REDUCING VALVE FLANGERS	6"	6"	10"		
11	1	DA. X 1/2" 7/8" DIP FLANGERS	4"	6"	8"	CLA-VAL MODEL 90-01 RC	
12	1	PRESSURE REDUCING VALVE THROTH	4"	6"	8"	CLA-VAL MODEL 90-01 RC	
13	2	DA. X LENGTH GATE PIPE THROTH	2"	3"	3"	FIELD ADJUST LENGTH	
14	2	DA. X LENGTH GATE PIPE THROTH	2"	3"	3"	FIELD ADJUST LENGTH	
15	1	DA. X LENGTH GATE PIPE THROTH	2"	3"	3"	FIELD ADJUST LENGTH	
16	2	DA. X LENGTH GATE PIPE THROTH	2"	3"	3"	FIELD ADJUST LENGTH	
17	2	DA. X LENGTH GATE PIPE THROTH	2"	3"	3"	FIELD ADJUST LENGTH	
18	2	90° GALV. BEND THROTH	2"	3"	3"		
19	2	DA. X 90° GALV. PIPE THROTH	2"	3"	3"		
20	2	BEND FLANGE W/ THROTH TAP	2"	3"	3"		
21	1	8" X 2" CONCRETE CATCH BASIN	4"	6"	8"	SUMP FOR SUBSURFACE WATER	
22	1	PRE-CORR HOLES FOR DRAIN PIPE TO DRAINAGE	4"	6"	8"	"HUMP HOLE" IF NO SUBSURFACE WATER	
23	6	TEES	4"	6"	8"		
24	1	A-1181 DAL MANHOLE RING AND COVER	4"	6"	8"	"WATER" GRADE RING IF NEEDED	
25	1	DA. X LENGTH DIP FLANGE	4"	6"	8"	4"-2"	
26	1	DA. X 2" DIP FLANGE	4"	6"	8"		
27	1	DIP SLEEVE MANHOLE	4"	6"	8"		
28	1	DA. X 1" DIP FLANGE	4"	6"	8"		
29	1	RESTRAINED FLANGED COUPLING ADAPTER	4"	6"	8"		
31	4	PIPE STAND				H2O LOADING	
32	1	6" X 12" X 3" TALL PRECAST CONCRETE VALVE	1"	1.433"	2"	1.833"	APRO MODEL 120C RING W/ FITTINGS
33	1	SCREWED GATE VALVE	1"	1"	2"		
34	1	1/2" SMOOTH NOSE TAP	3/4"	3/4"	3/4"	W/ FITTINGS	
35	1	SCREWED GATE VALVE	4"	6"	8"	W/ FITTINGS	
36	1	CROSS	4"	6"	8"		
37	1	SCREWED GATE VALVE	4"	6"	8"	FNPT	
38	1	RELIEF/SUSTAINING VALVE	2"	3"	4"	CLA-VAL 50-1 OR EDL	
39	1	CORE AND GROUT	5"	6"	8"	FNPT	
40	1	GALVANIZED STEEL PIPE (GSP)	2"	3"	4"	TAP INSIDE VALVE FOR DRAINAGE	
41	1	ELBOW GSP	2"	3"	4"		
42	1	NON-CORRODIBLE	2"	3"	4"		
43	1	CONCRETE COLLAR	12" DIA	12" DIA	12" DIA		

\* TO BE DETERMINED BY SITE \*\* 8" CROSS MAY USE 8"x4" CROSS W/DIP FITTINGS FOR RELIEF VALVE. VERIFY WITH OWNER AND ENGINEER

WATER DETAILS  
OSPREY RANCH  
1800 N HYW 158  
EDEN, WEBER, UTAH

**GARDNER ENGINEERING**  
CIVIL-LAND PLANNING  
MUNICIPAL-LAND SURVEYING

5150 SOUTH 375 EAST OGDEN, UT  
OFFICE: 801-476-0202 FAX: 801-476-0066

DT4

SCALE: \*\*\*\*\*  
DATE: 01-21-22  
DESIGN: KAN  
DRAWN: KAN  
CHECKED: RC

REVISIONS  
DATE DESCRIPTION

# SEWER DETAILS

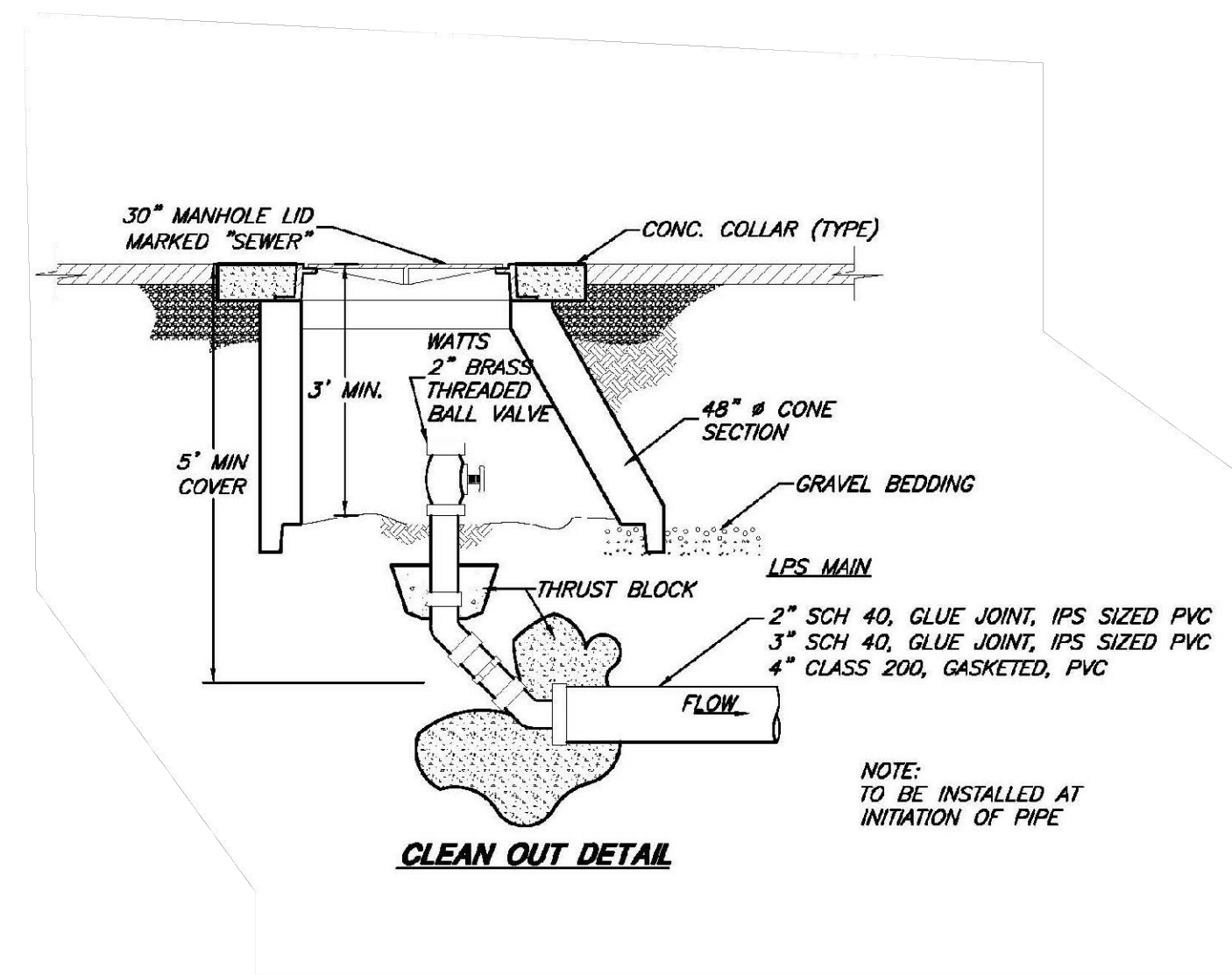
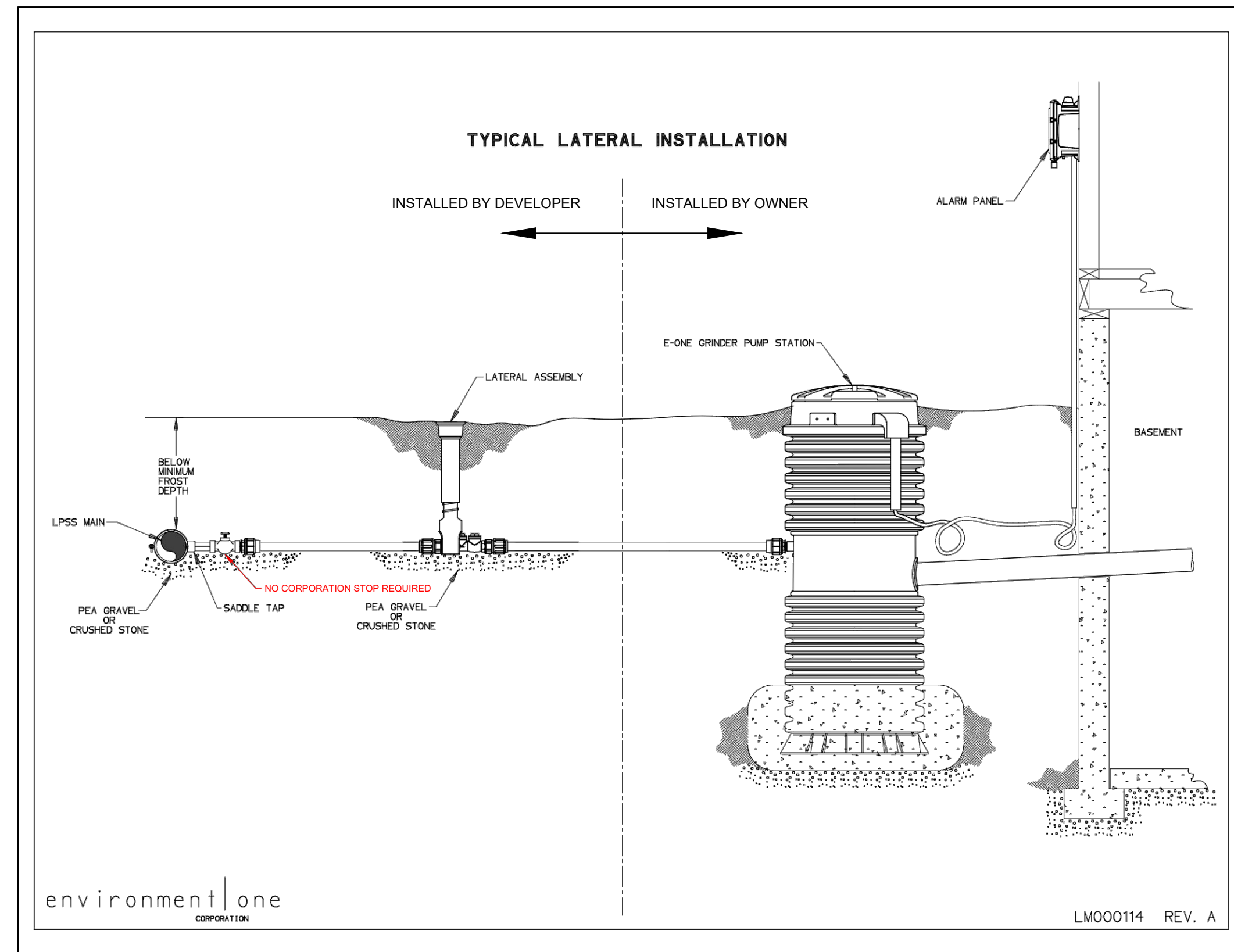

LOW PRESSURE - SEWER CLEAN OUT

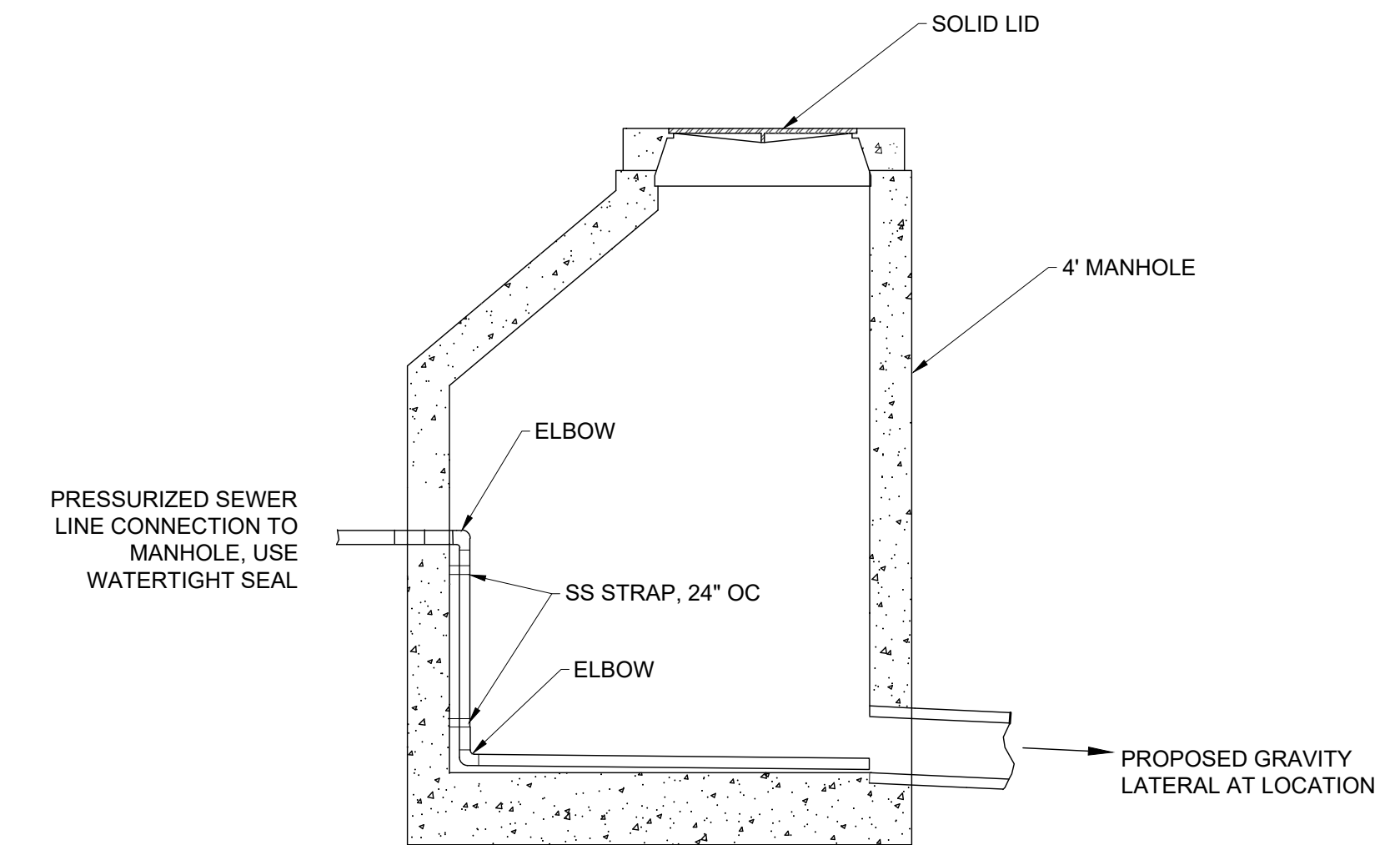

PRESSURE LINE CONNECTION TO MANHOLE (TYP.)

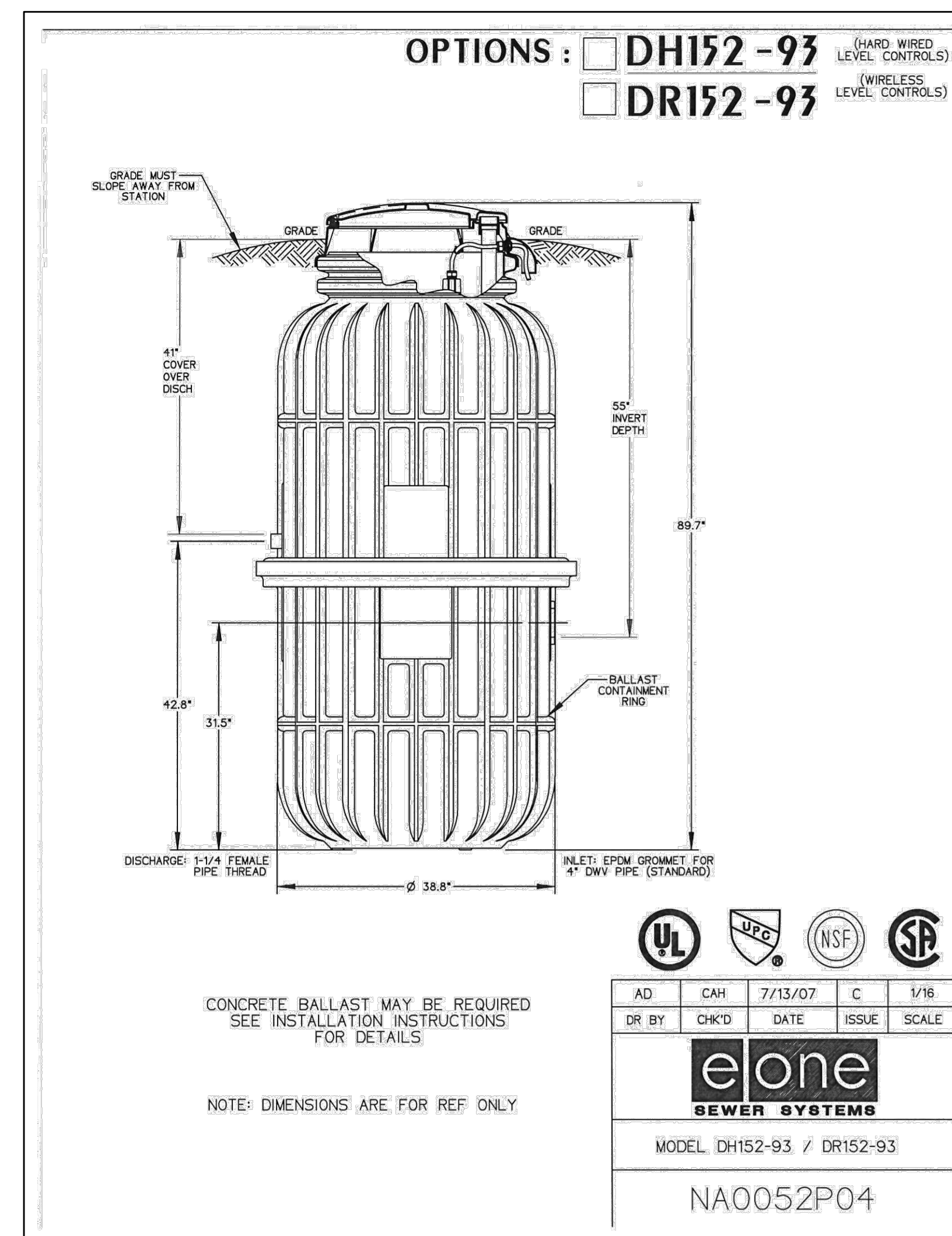
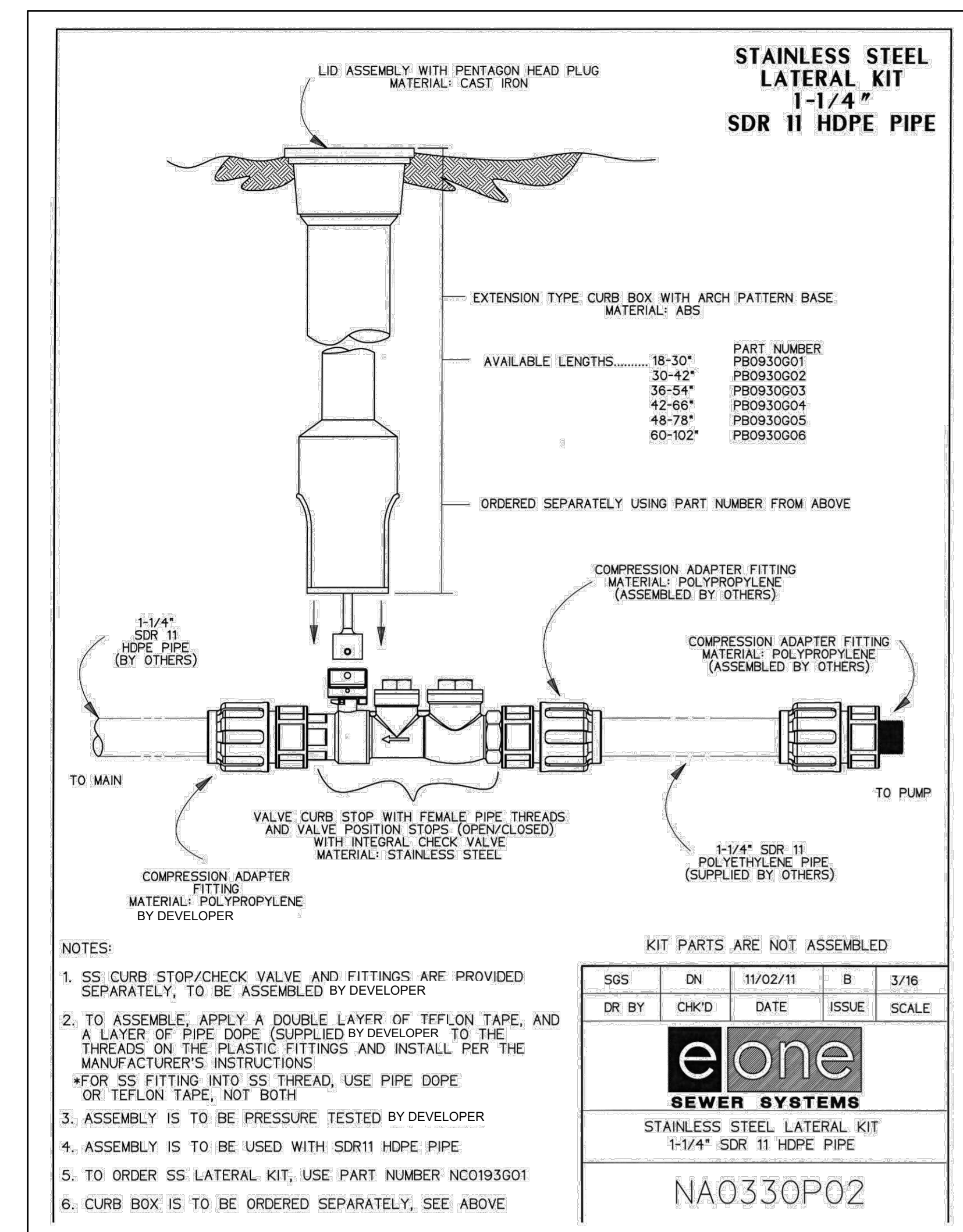

INTERMITTENT PUMP

SCALE	DATE	DESIGN	DRAWN	CHECKED
1/8" = 1'-0"	01-21-22	KAN	KAN	PC

REVISIONS	DESCRIPTION
DATE	

DWG. # 11/201 - LEWIS HOMES, 2105 - OSPREY RANCH, DESIGN, DWG, OSPREY UTILITY PLANNING

SEWER DETAILS  
OSPREY RANCH  
1800 N HYW 158  
EDEN, WEBER, UTAH

**GARDNER ENGINEERING**  
CIVIL - LAND PLANNING  
MUNICIPAL - LAND SURVEYING

5150 SOUTH 375 EAST OGDEN, UT  
OFFICE: 801-476-0202 FAX: 801-476-0066