



VAQUERO VILLAGE SUBDIVISION PHASE 2 SECONDARY WATER MODEL
APPROX 900 South 7100 WEST
WEBER COUNTY, UTAH 84404
SECONDARY WATER MODEL

Project No. 20N707

11-24-2020

General Site Information:

The proposed Vaquero Village Subdivision site is located on the North side of 900 South, about 7100 West in Weber county Utah. Construction will consist of a new 15 Lot Residential Subdivision, public roadways, two open spaces parcels, sidewalks, curb and gutter, underground utilities (including a secondary water system, herein after referred to as the “System”), a detention pond, and a secondary water reservoir when completed. Secondary water will be supplied via a metered piped system including water pumps, a 6-inch diameter main line, 1.5-inch laterals, and 1.0-inch individual lot connections.

Supply for the System will come gravity-fed from a nearby irrigation ditch. The water will be stored in the afore-mentioned pond/reservoir until used. Pumps will be provided which will deliver water through new secondary water piping to each of the 15 lots in phase two of the subdivision, and one of the open space parcels. The design meets the requirements set forth by Marriot Slaterville. The attached figure shows the secondary water Layout and the lot layout for the subdivision.

Design Requirements:

The system has designed for an average secondary water flow of at least 6 gpm per irrigable acre (for a 183-day irrigation season). Also required is for the design to provide a peak instantaneous flow of $Q \text{ (gpm)} = 180 * U * N^{0.55}$, where U is the usage factor, and N is the total number of Irrigable Acres. Pressures are required to be between 60 and 100 psi. Minimum main line size is 6-inch diameter and 1.5-inch/1.0-inch for common/single laterals. A diameter of 6-inches was selected for all main lines in this model. The design conforms with Marriott -Slaterville City Standards for Secondary Water, in particular, Sheets CS-16 and CS-16a are to be followed, which detail the pumping/metering system along with the Pump Control & Filter Station. A copy of the Standards and Detail Sheets are attached to this report.

Watering days will be split so that even-numbered lots are allowed to water on certain days. Odd-numbered lots will be allowed to water on other days so that there is no overlap in usage for these two groups of lots. Open space Parcel E will be allowed to water without restriction.

Model Software and Input:

The software used for this analysis is EPANET 2.2, which is a free service that is available on the epa.gov website. Naming conventions for junctions (nodes) and pipes (links) are as follows:

- Connection nodes for individual lots are labeled simply by the lot number. For example, the node serving as connection for Lot 207 is labeled as “207”.
- The short 1-inch diameter laterals that lead to the connection nodes are labeled with a “P” followed by the corresponding lot number. For example, the short lateral serving Lot 207 is labeled as “P7”.
- The nodes on the upstream ends of the 1-inch laterals are labeled by letters “a” through “h” and are organized from south to north. For example, the node on the upstream end of P7 is labeled simply as “h”
- The 1.5-inch laterals that connect to the main lines are labeled with a capital “L” followed by a letter “a” through “h” to correspond to its downstream node designation. For example, the 1.5-inch lateral that feeds node g is labeled as “Lg”
- The remaining nodes are along and at tie-in locations to the 6-inch main lines and are labeled “m1” through “m9” in a northerly fashion. For example, the junction in the cul-de-sac nearest Lot 7 is labeled as “m9”.
- The 6-inch main lines are designated with an “M” followed by a number “1” through “9” in a northerly fashion. For example, the main line heading south from the northern cul-de-sac is labeled as “M_9”.

To model the System, a headloss vs. flow curve and a head vs. flow curves were needed to incorporate the water meter and the water pumps, respectively. The Pump Control & Filter Station Details indicate the requirement of a “Water Specialties” Meter and at least two “Grundfos” SP or SQ (or equal) water pumps. The respective manufacturer’s websites were consulted to locate suitable choices. For the Meter, a 3-inch ML-07 Meter was selected. For the pumps, two SP (150S150-6 – 13B63006) pumps were selected. Corresponding headloss/head (ft) vs. flow (gpm) curves and O&M manuals are attached to this report.

A general purpose valve (Called “GPV” in EPANET) was used and assigned a flow vs. headloss curve to simulate the effects of the selected Meter in this Model. This valve is labeled “Meter” on the attached exhibits. Measurements were taken on the flow vs. headloss curve in order to add the information to this curve assigned to the GPV. Since EPANET uses units of feet for head/headloss, the pressures (psi) found on the headloss curve were converted to feet for use in EPANET.

The water pumps were modeled as “pumps” in EPANET. They are labeled as “Pump.1” and “Pump-2” on the attached exhibits. For peak flow analyses, both pumps are assumed on. For average flow analyses, Pump.2 is assumed closed, and Pump.1 is running at 75% speed (using a variable frequency drive, VFD). The provided Grundfos pump curve is attached to this report for reference.

A Peak Instantaneous Flow (PIF) rate was calculated by using the equation in the “Design Requirements” section of this narrative for this 15-Lot Subdivision. Each lot will be allowed up to 10,000 sf of landscaping, and Open Space E will be allowed 20,000sf. This yields a maximum total landscaping area of $15 * 10,000 + 20,000 = 170,000$ sf, which is 3.90 acres. A usage factor of 0.85 was used.

The peak flow is then calculated as:

$$\text{PIF} = 0.85 * 180 * 3.90^{0.55} = 324 \text{ gpm}$$

Likewise, the Average Flow (AF) was calculated as:

$$\text{AF} = 3.90 \text{ ac} * (6 \text{ gpm} / \text{irrig-ac}) = 23.4 \text{ gpm}$$

Modeled Scenarios:

Four Scenarios are analyzed using the EPANET model. For peak flows, the entire 324 gpm is distributed evenly across the 7 even numbered lots, and the Open space parcel which provides 40.5gpm/lot. Additionally, for peak flows the entire 324 gpm is distributed evenly across the 8 odd numbered lots and Open Space E, which gives 36.0gpm/lot.

Similarly, for the average flow rates, the 23.4 gpm is divided by the 7 or 8 allowable lots plus the open space parcel, which gives 2.92 and 2.6 gpm/lot for the even and odd numbered lots, respectively. The four scenarios are:

1. Average flows for odd-numbered lots plus the open space parcel.
2. Average flows for even-numbered lots plus the open space parcel.
3. Peak flows for odd-numbered lots plus the open space parcel.
4. Peak flows for even-numbered lots plus the open space parcel.

Data showing specifics for the pipe and node properties can be found in the attached exhibits (Appendix A) and calculations/results (Appendix D) as well.

The results are sorted by elevation for nodes, and length for pipes to make it easier to analyze/critique the data.

Results:

Under average flow scenarios (using only one pump at 75% speed), all connection points have pressures between 60 and 100 psi, as required. Likewise, under peak flow scenarios (using both pumps at 100% speed), all connection point also have pressures between 60 and 100 psi. For pipes larger than the 1.5-inch and 1-inch laterals, the peak flow velocities are less than 4 fps, as required. With the requirement of 1-inch laterals for individual lots, velocities are 16.5 fps to deliver the peak flows of 40.5 gpm to each lot.

Great Basin Engineering, Inc.

Prepared by:
James Ries EIT

Reviewed by:
Ryan Bingham, P.E.

APPENDICES

Appendix A – Maps

Appendix B – Design Parameters and Details

Appendix C – Head / Headloss Curves

Appendix D – Model Results

Appendix E – Pump and Meter O&M Manuals

APPENDIX A

Maps

Vaquero Village Secondary Water Pipe Map

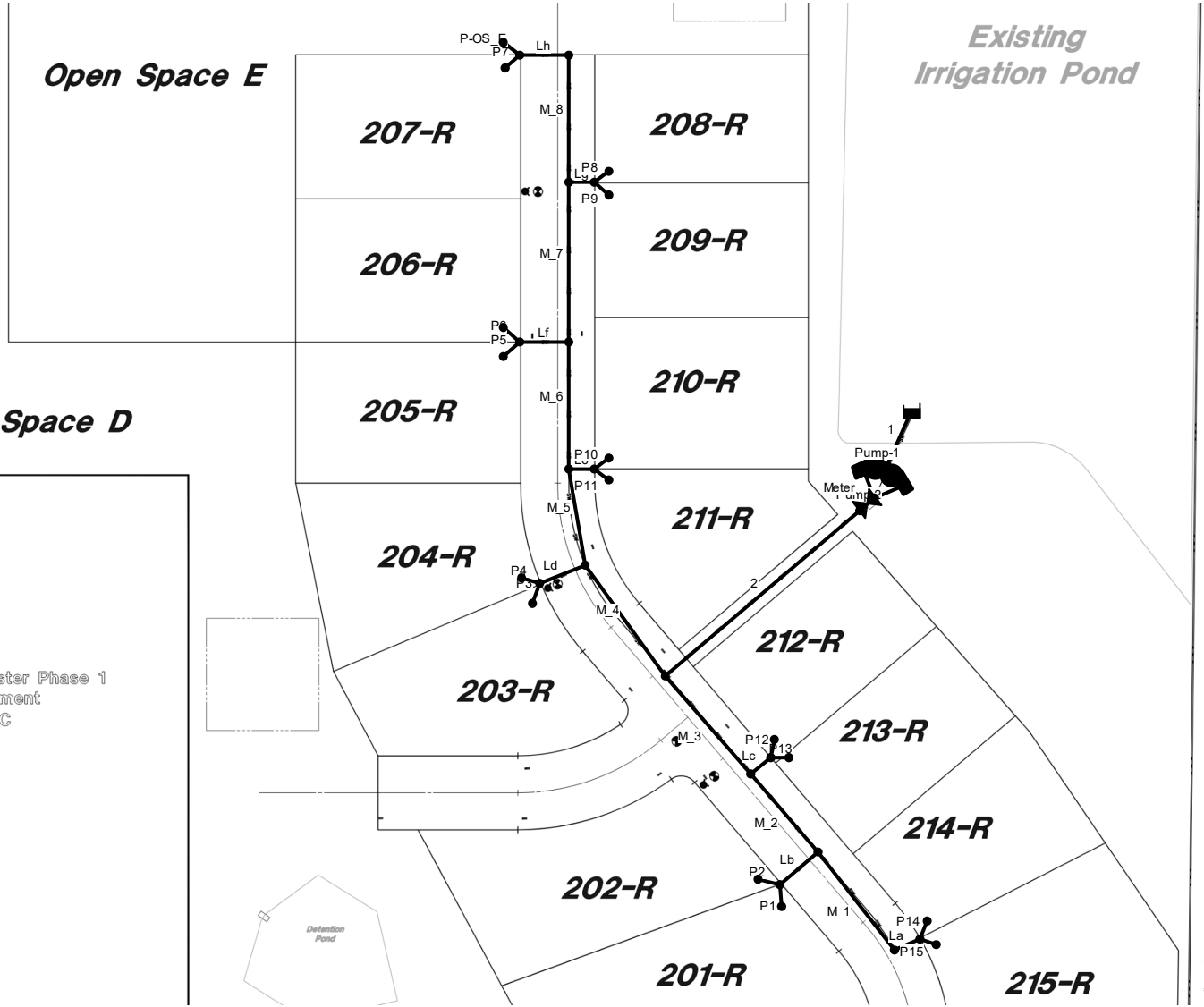

The Melros Family Partnership

Vaquero Village Secondary Water Node Map

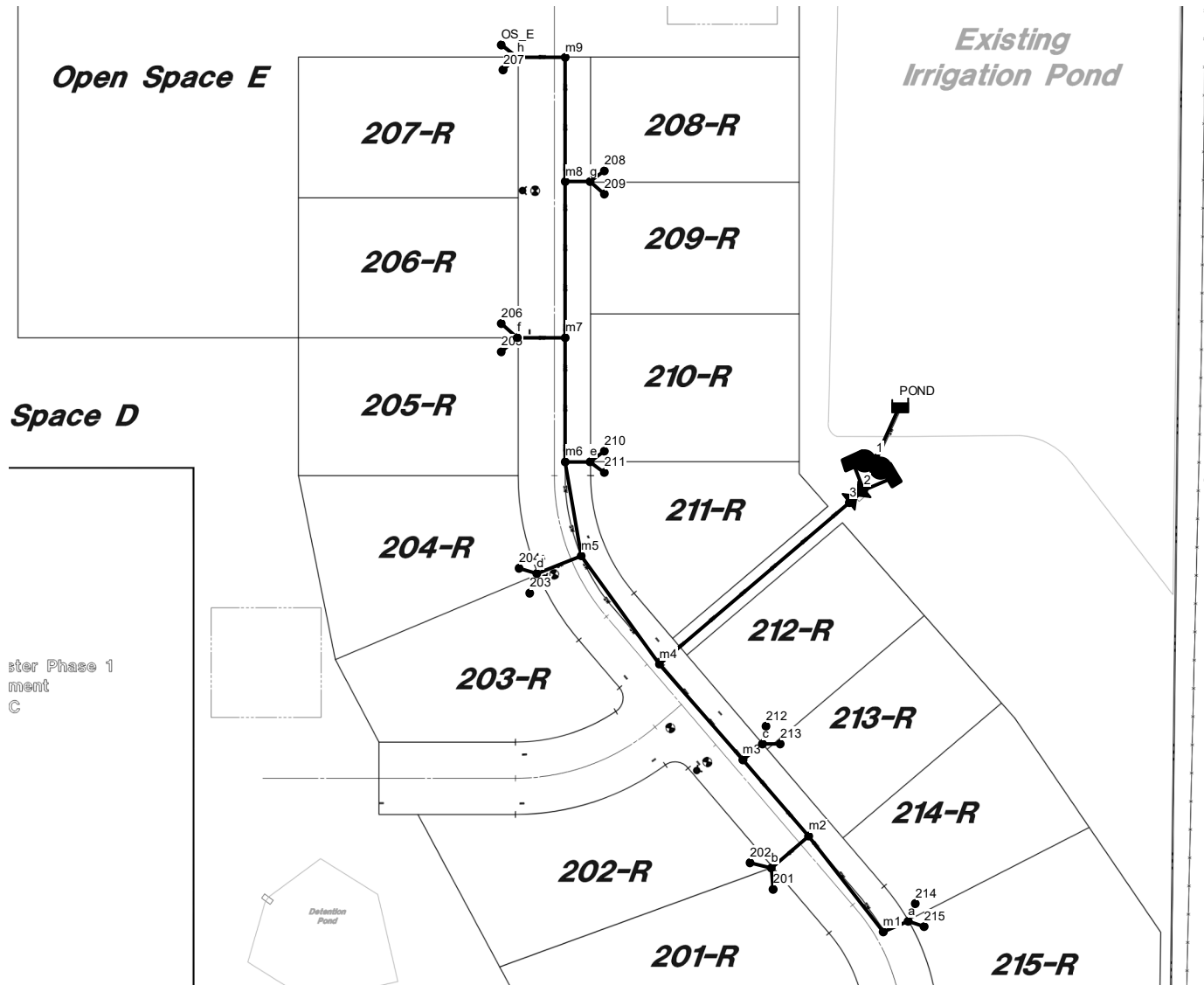

Vaquero Village Secondary Water Pump and meter detail

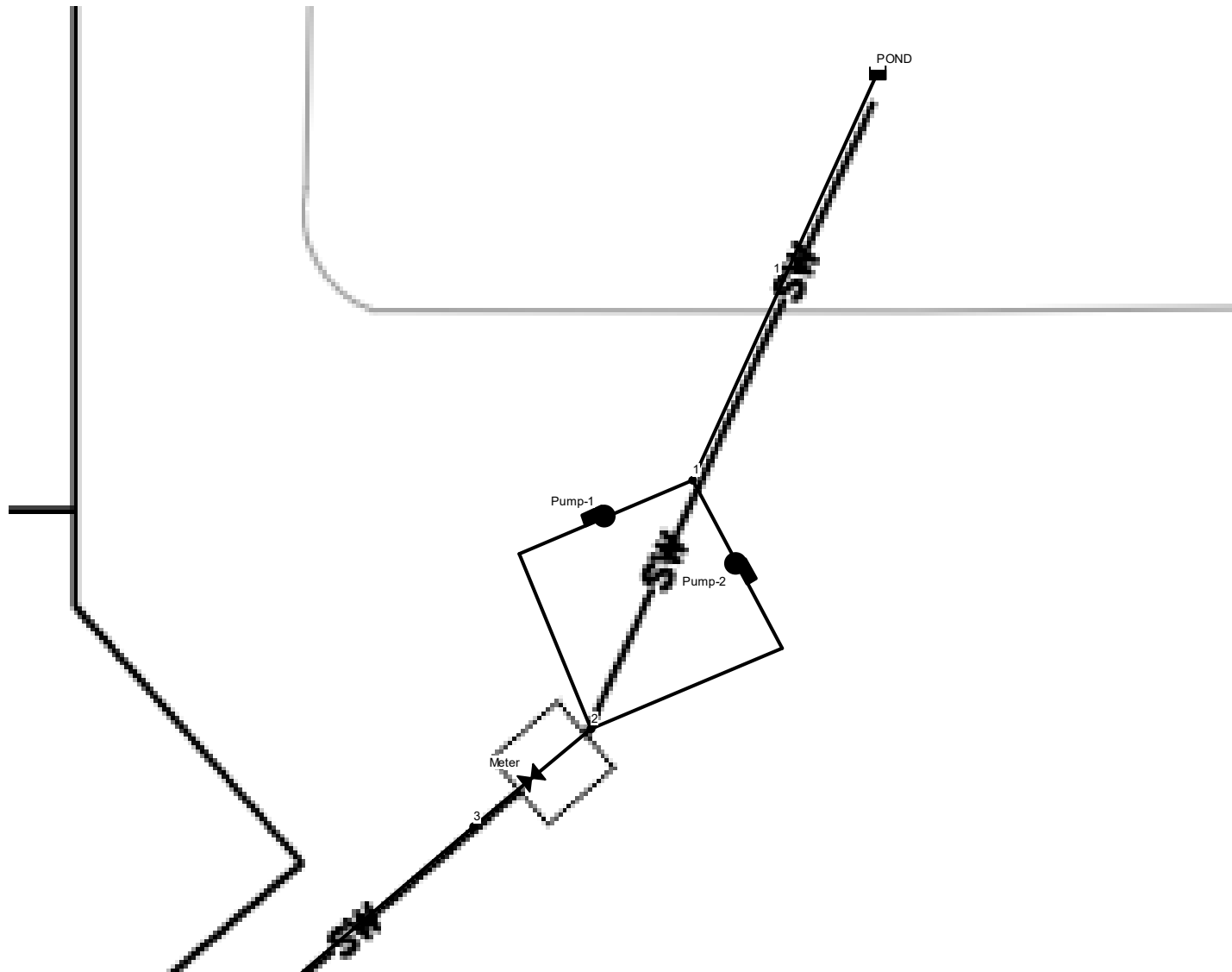

APPENDIX B

Design Parameters and Details

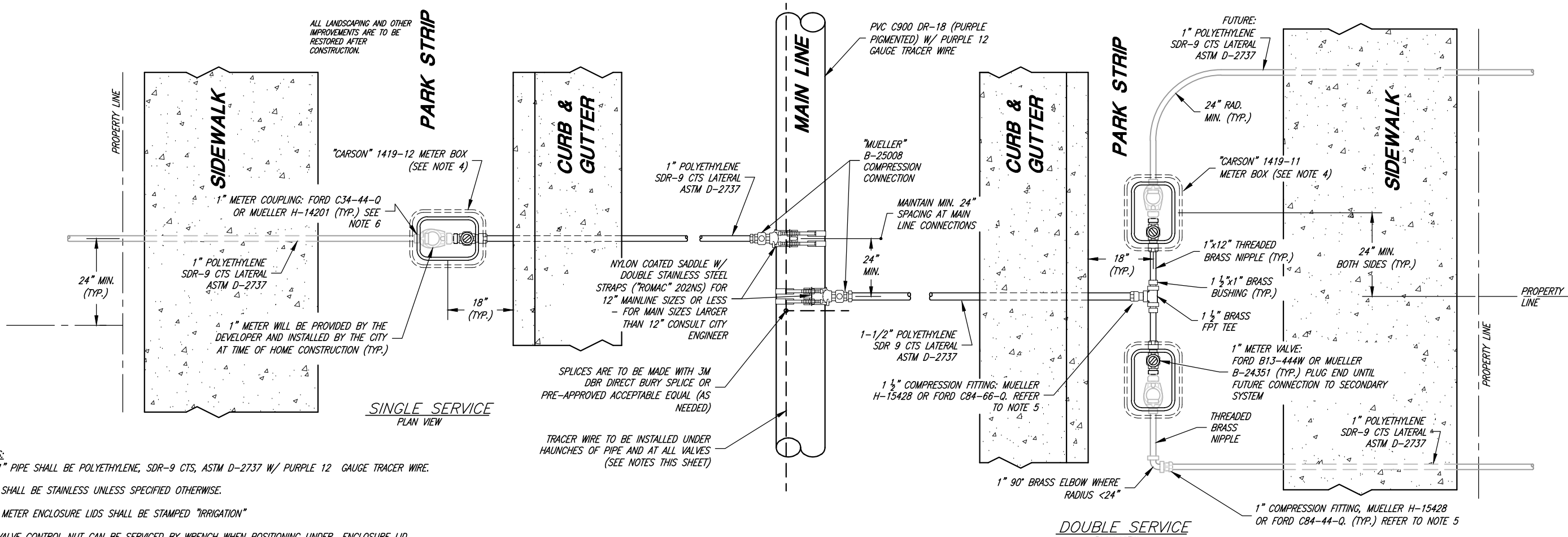

- GENERAL NOTES:**
1. 1 1/2" & 1" PIPE SHALL BE POLYETHYLENE, SDR-9 CTS, ASTM D-2737 W/ PURPLE 12 GAUGE TRACER WIRE.
 2. FITTINGS SHALL BE STAINLESS UNLESS SPECIFIED OTHERWISE.
 3. VALVE & METER ENCLOSURE LIDS SHALL BE STAMPED "IRRIGATION"
 4. INSURE VALVE CONTROL NUT CAN BE SERVICED BY WRENCH WHEN POSITIONING UNDER ENCLOSURE LID.
 5. ALL COMPRESSION-TYPE CONNECTIONS REQUIRE STAINLESS STEEL INSERT STIFFENERS.
 6. THE TUBING SHOULD BE INSERTED INTO THE FITTING SO THAT THE END OF THE TUBING IS WELL PAST THE RUBBER GASKET AND AT LEAST 1/8" FROM THE BOTTOM OF THE SOCKET.
 7. SERVICE LINES ARE TO BE TAPPED LEVEL
 8. ALL MAIN LINES ARE TO BE PURPLE C900 W/ PURPLE LOCATOR TAPE & PURPLE 12 GAUGE TRACER WIRE.

- TRACER WIRE NOTES:**
- A1. ALL SECONDARY WATER LINES SHALL HAVE A MINIMUM 12 GA. INSULATED TRACER WIRE INSTALLED UNDER THE HAUNCHES OF THE PIPE PRIOR TO BACKFILLING.
 - A2. TRACER WIRES SHALL TERMINATE AT ALL METERS. AT SERVICE SADDLES AND TAPPING SLEEVES, THE TRACER WIRE SHALL NOT BE ALLOWED TO BE PLACED BETWEEN THE SADDLE AND THE PIPE. A GROUNDING ROD SHALL BE INSTALLED AT ALL TRACER SYSTEM TERMINAL POINTS.
 - A3. TRACER WIRE SHALL BE COPPER WIRE WITH PURPLE INSULATION RATED FOR DIRECT BURIAL. ALL WIRE CONNECTORS SHALL BE 3M DBR DIRECT BURY SPLICE OR PRE-APPROVED ACCEPTABLE EQUAL AND SHALL BE WATERTIGHT TO PROVIDE ELECTRICAL CONTINUITY.
 - A4. ALL TRACER WIRE SHALL BE TESTED FOR CONTINUITY IN THE PRESENCE OF THE PUBLIC WORKS INSPECTOR PRIOR TO ASPHALT PLACEMENT. ANY TRACER WIRE FOUND NOT TO BE CONTINUOUS AFTER TESTING SHALL BE REPAIRED OR REPLACED BY THE CONTRACTOR PRIOR TO ASPHALT PLACEMENT.

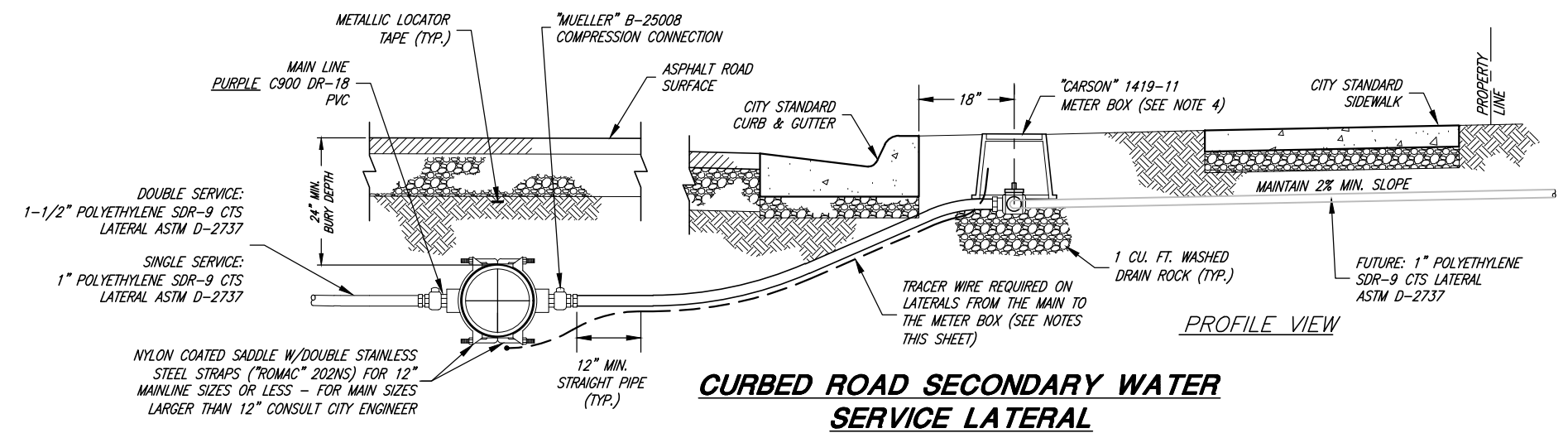

CURBED ROAD SECONDARY WATER SERVICE LATERAL

PROJECT ENGINEER	REV.	DATE	APPR.
DATE			

SCALE: N.T.S.

DESIGNED _____
 DRAWN _____
 CHECKED _____

JA JONES & ASSOCIATES
 CONSULTING ENGINEERS
 6080 Fashion Point Drive
 South Ogden, Utah 84403 (801) 476-9767
 www.jonescivil.com

HARRISVILLE CITY CORPORATION
 PUBLIC WORKS STANDARDS

SECONDARY WATER - TYPICAL SERVICE LATERALS

SHEET: **CS-14**
 OF SHEETS: 0

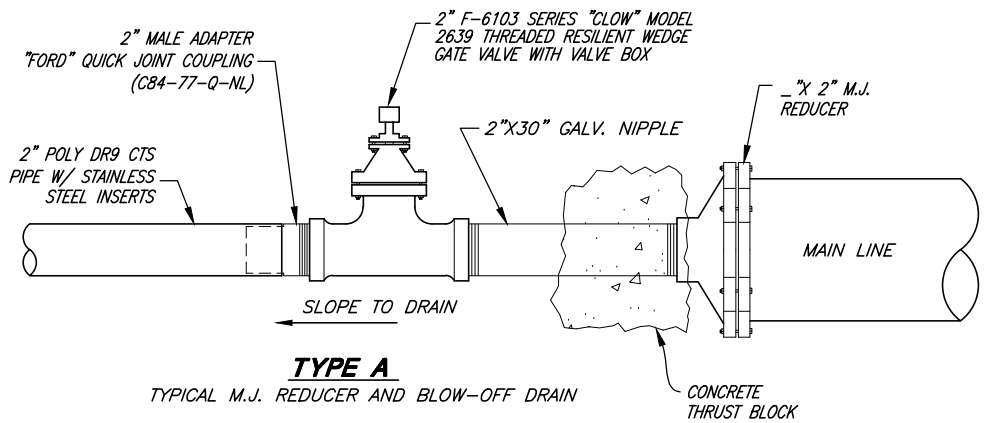

TYPE A
TYPICAL M.J. REDUCER AND BLOW-OFF DRAIN

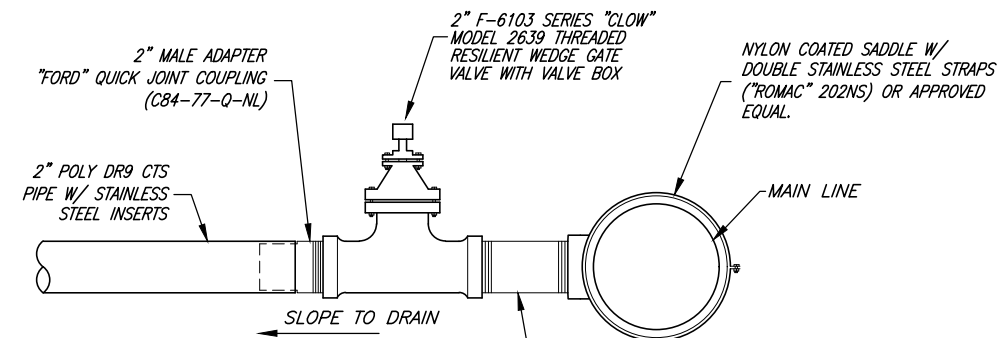

TYPE B
TYPICAL DRAIN

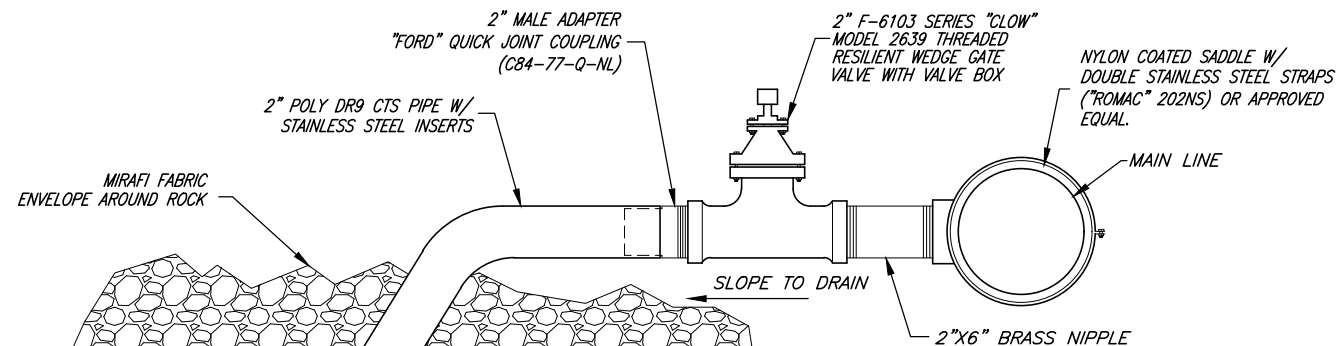

TYPE C
TYPICAL SUMP DRAIN

NOTE:
CONNECT SECONDARY WATER DRAIN TO STORM DRAIN WHERE APPLICABLE

FILL 6'X6'X6' HOLE WITH 1" ROCK

DRAIN VALVE DETAILS

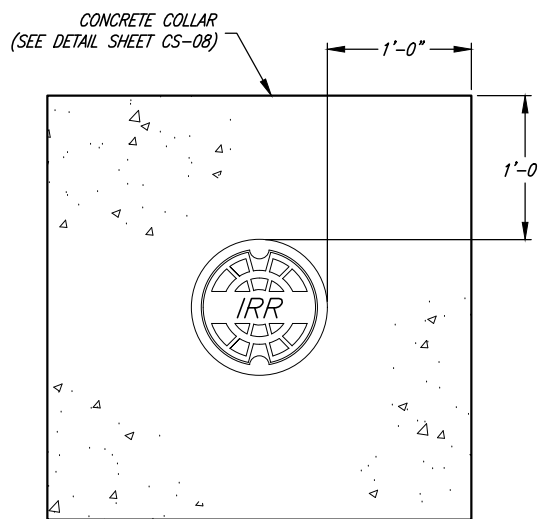

TYPICAL CONCRETE COLLAR

NOTE:
LID FOR SECONDARY WATER TO BE STAMPED "IRR" OR "IRRIGATION".

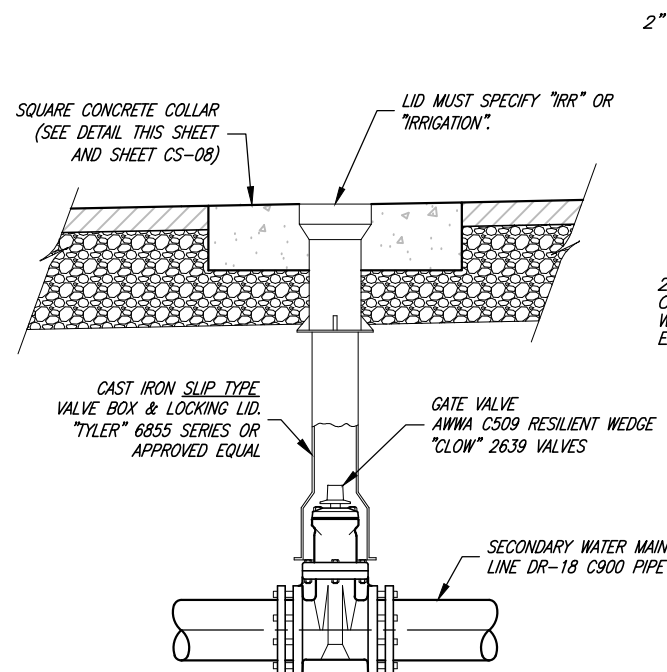

GATE VALVE DETAIL

GENERAL NOTES:

- "BLUE" BOLTS AND NUTS ARE REQUIRED BY THE CITY.

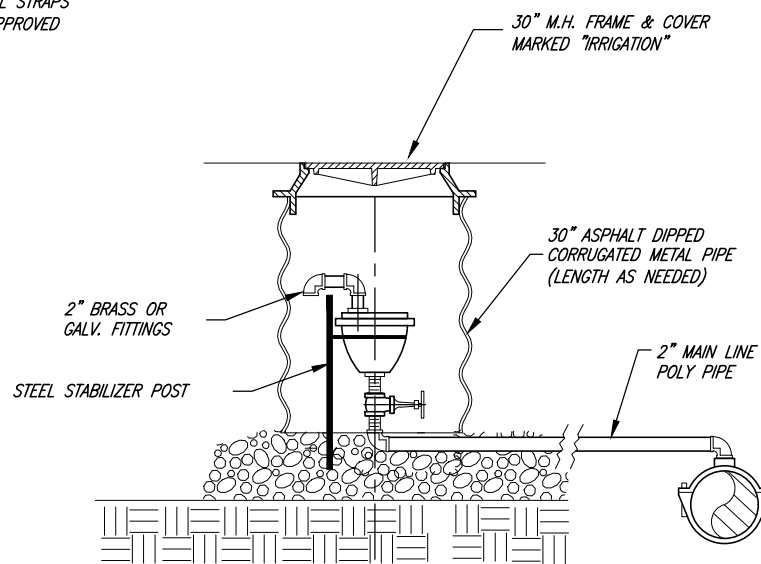

**AIR VACUUM & AIR RELEASE VALVE
PARK STRIP OR SHOULDER INSTALLATION**

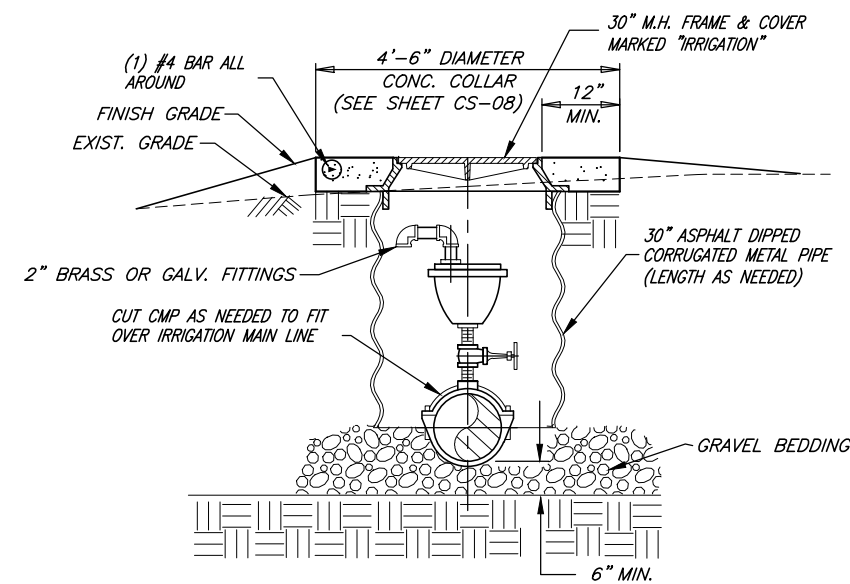

**AIR VACUUM & AIR RELEASE VALVE
STREET INSTALLATION**

PROJECT ENGINEER	REV.	DATE	APPR.
DATE			

SCALE:

N. T. S.

DESIGNED _____
DRAWN _____
CHECKED _____



CONSULTING ENGINEERS
6080 Fashion Point Drive
South Ogden, Utah 84403 (801) 476-9767
www.jonescivil.com

HARRISVILLE CITY CORPORATION
PUBLIC WORKS STANDARDS
**SECONDARY WATER - AIR/VAC, DRAIN,
CONCRETE COLLAR, & GATE VALVE DETAILS**

SHEET:
CS-15
OF SHEETS
0

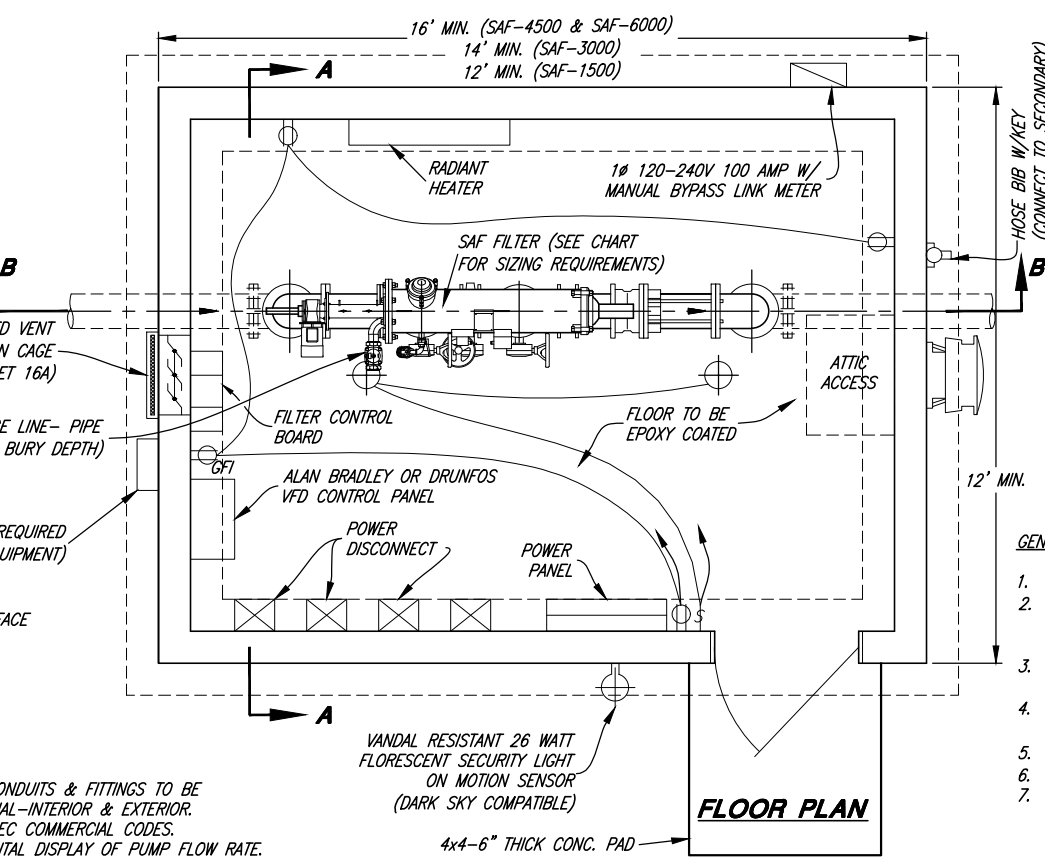
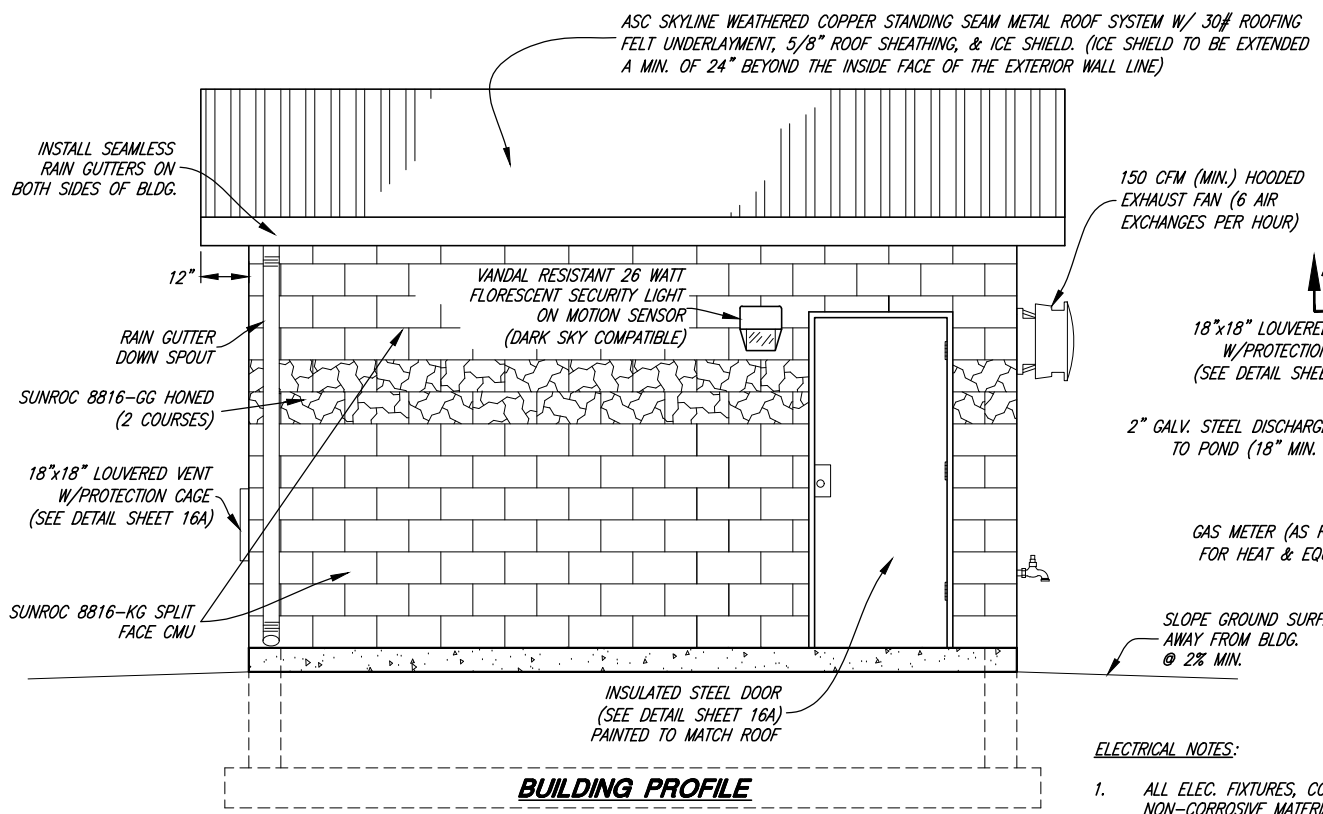

AMIID MODEL "SAF" FILTER				
MODEL	MIN. LINE SIZE	MAX. FLOW	DIM "A"	DIM "B" MIN.
2" SAF-1500	3"	100 GPM	13.8"	2.66'
3" SAF-1500	4"	200 GPM	13.8"	2.66'
4" SAF-1500	6"	350 GPM	13.8"	2.66'
4" SAF-3000	6"	400 GPM	24.4"	3.94'
6" SAF-3000	8"	660 GPM	24.4"	3.94'
6" SAF-4500	10"	880 GPM	24.4"	4.92'
8" SAF-4500	10"	1100 GPM	24.4"	4.92'
8" SAF-6000	12"	1400 GPM	24.4"	4.26'
10" SAF-6000	12"	1760 GPM	24.4"	4.26'

- AMIID FILTER NOTES:**
- SCREEN TO BE 200 MICRON
 - CONTROL TO BE STAINLESS STEEL
 - FILTER LID TO BE EPOXY COATED STEEL
 - CLEANING MECHANISM TO BE STAINLESS STEEL
 - EXHAUST VALVE TO BE EPOXY COATED CAST IRON.
- GENERAL NOTES:**
- ALL PIPE SHALL BE DUCTILE IRON CLASS 50 UNLESS OTHERWISE NOTED.
 - ALL STRUCTURAL CONSTRUCTION SHALL COMPLY W/CURRENT ICC & LOCAL BUILDING CODES & SHALL BE CONSISTENT WITH COMMON CONSTRUCTION PRACTICES OF THE TRADES.
 - EARTH TONE CMU BLOCK COLOR TO BE SELECTED BY THE CITY (SEE DETAILS).
 - METAL ROOF, FASCIA TRIM & SOFFIT, & METAL DRIP EDGE COLOR TO BE SELECTED BY THE CITY (SEE DETAILS).
 - IRRIGATION LINE IS TO HAVE 3" MINIMUM COVER.
 - ALL FLANGES TO BE ANSI CLASS 150/125
 - ALL PIPING, VALVES, FITTINGS, METERS, AND OTHER MISC. PARTS OF THE PIPING SYSTEM SHALL BE PAINTED W/1 COAT OF PRIMER AND 2 COATS OF ACRYLIC ENAMEL PAINT (PURPLE COLOR TO BE APPROVED BY THE CITY).

- ELECTRICAL NOTES:**
- ALL ELEC. FIXTURES, CONDUITS & FITTINGS TO BE NON-CORROSIVE MATERIAL-INTERIOR & EXTERIOR.
 - ALL ELEC. TO BE TO NEC COMMERCIAL CODES.
 - CONTROLS TO HAVE DIGITAL DISPLAY OF PUMP FLOW RATE.
 - THE READOUT SHOULD INCLUDE A READOUT SHOWING HERTZ IN PERCENTAGE OF MAX.

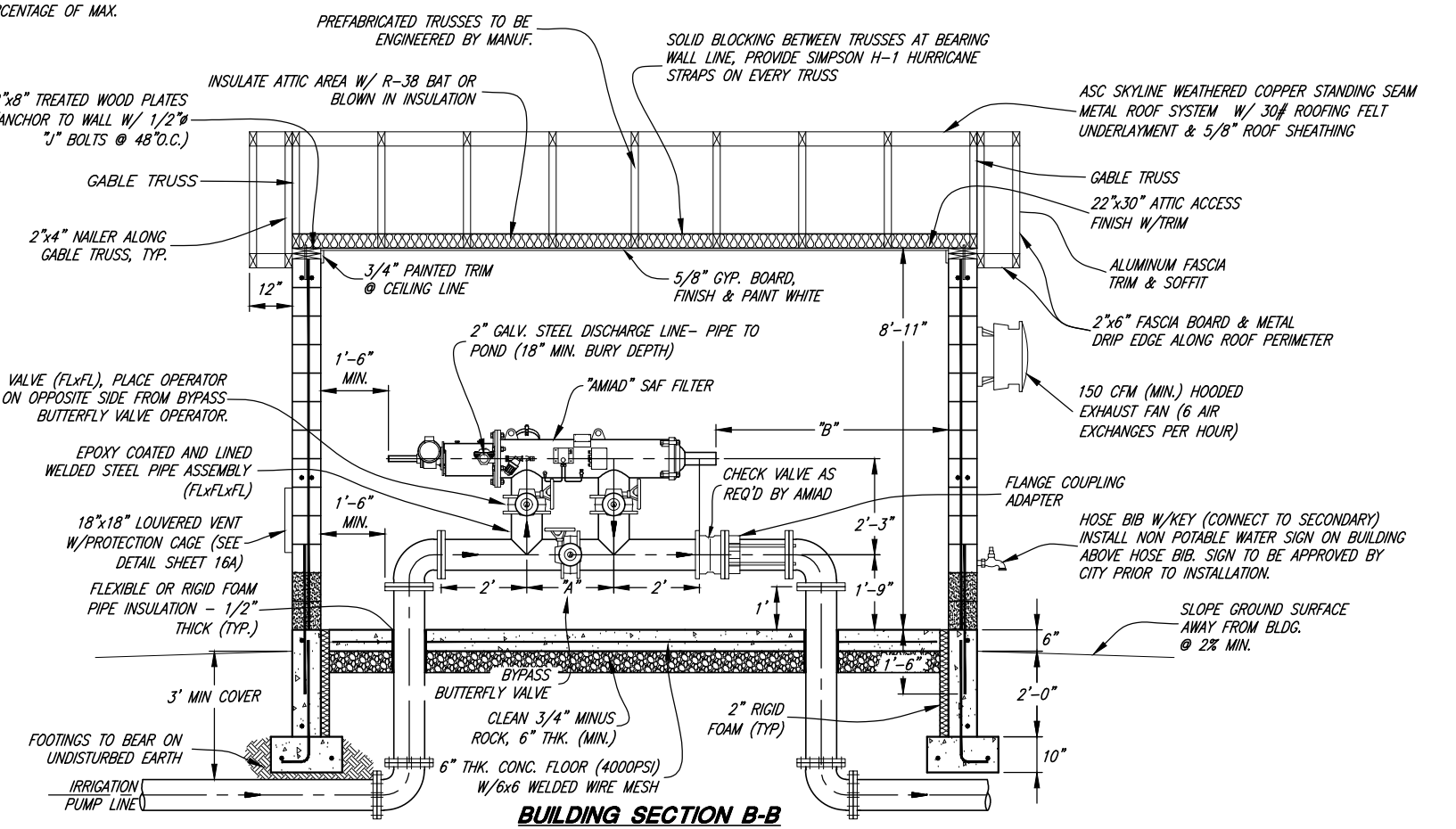
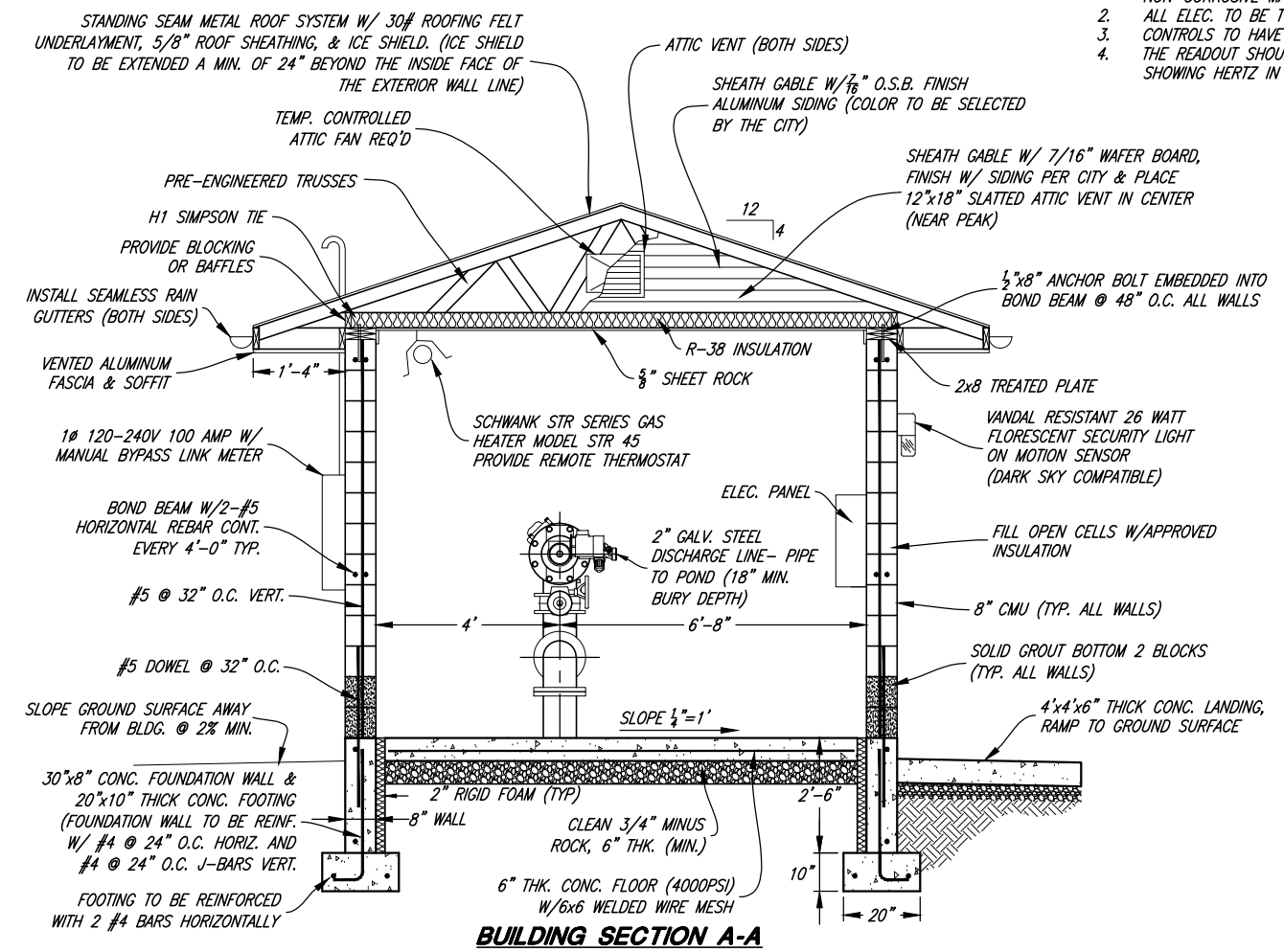

- NOTES:
1. ALL MANHOLE OR VAULT PIPE JOINTS ARE TO HAVE RUBBER BOOT OR OTHER APPROVED WATERTIGHT SEAL.
 2. COORDINATE INSTALLATION OF POWER TRANSFORMER & POWER LINE W/UP&L SIZE & CONST. TRANSFORMER PAD PER UP&L SPECS. TRANSFORMER TO BE SIZED FOR PUMPS & FILTER REQUIREMENTS.
 3. ALL D.I.P. IN CONTACT W/EARTH IS TO BE POLYETHYLENE ENCASED.

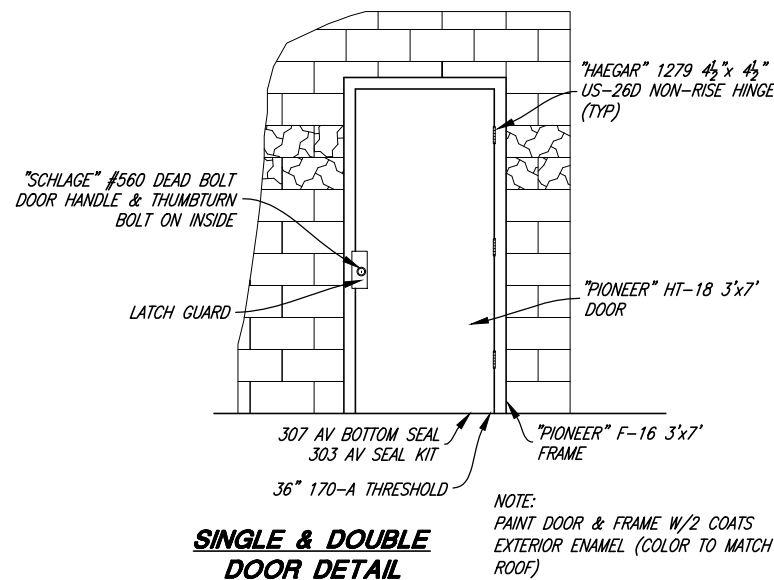
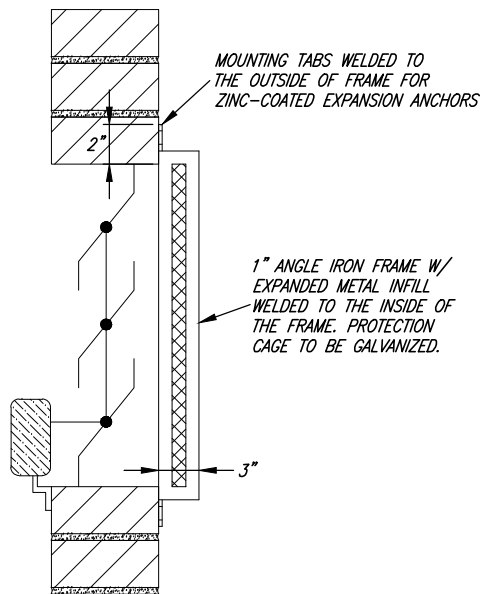
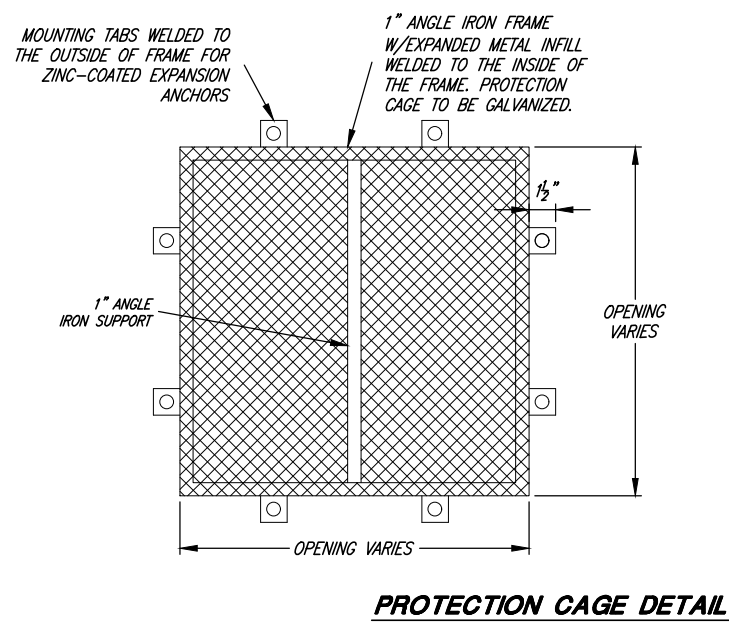
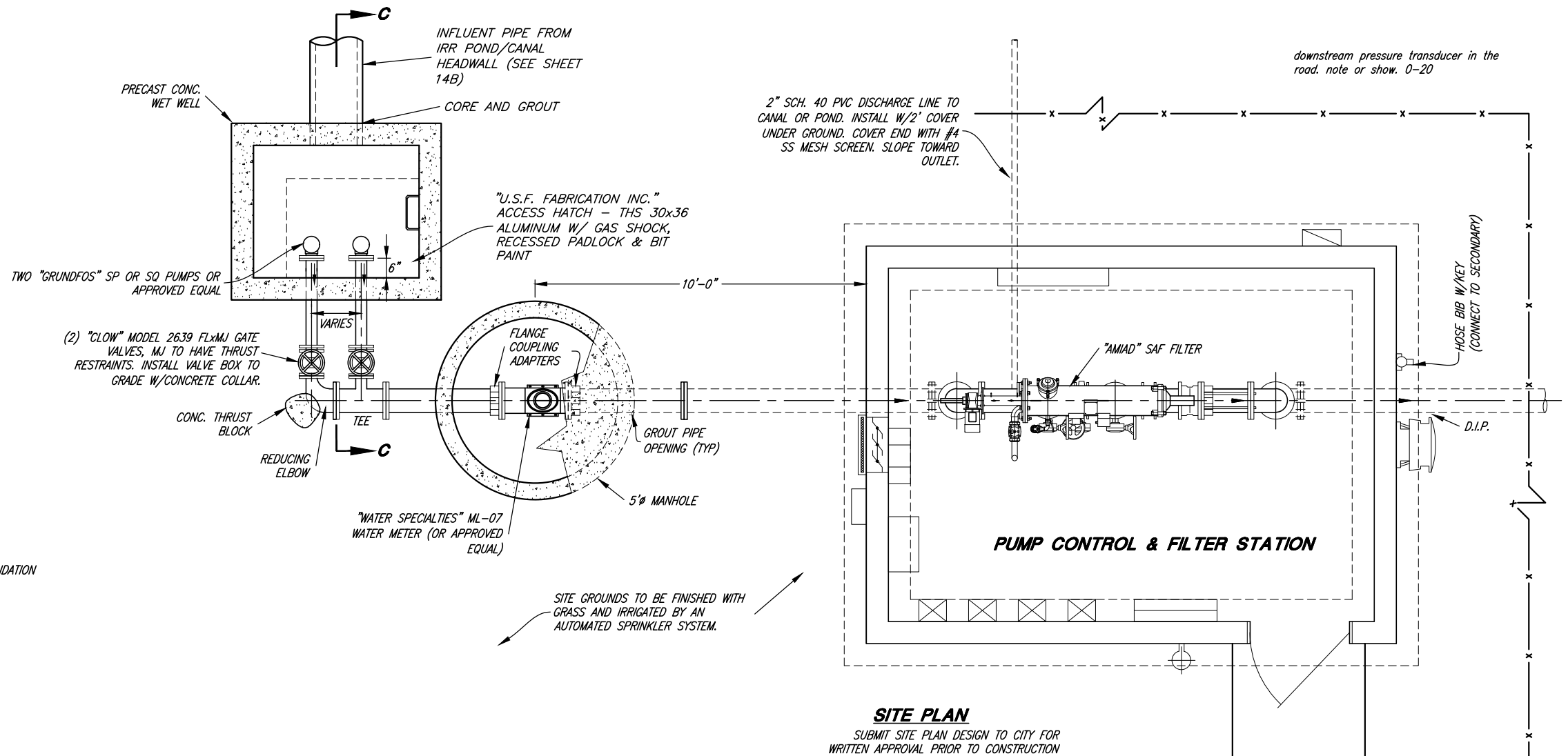
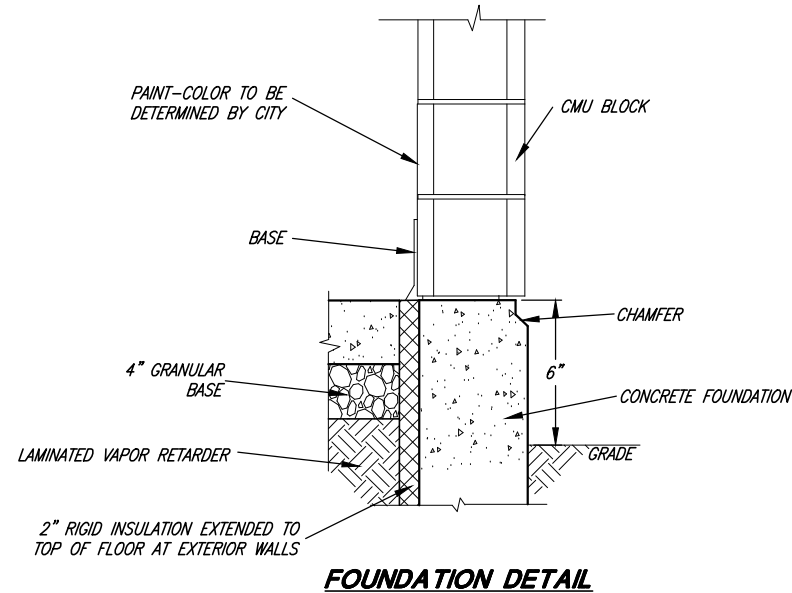

PROJECT ENGINEER	REV.	DATE	APPR.
DATE			

SCALE:
N.T.S.

DESIGNED _____
DRAWN _____
CHECKED _____



CONSULTING ENGINEERS
6080 Fashion Point Drive
South Ogden, Utah 84403 (801) 476-9767
www.jonescivil.com

HARRISVILLE CITY CORPORATION
PUBLIC WORKS STANDARDS
SECONDARY WATER - PUMP CONTROL & FILTER STATION DETAILS

SHEET:
CS-16a
OF SHEETS
0

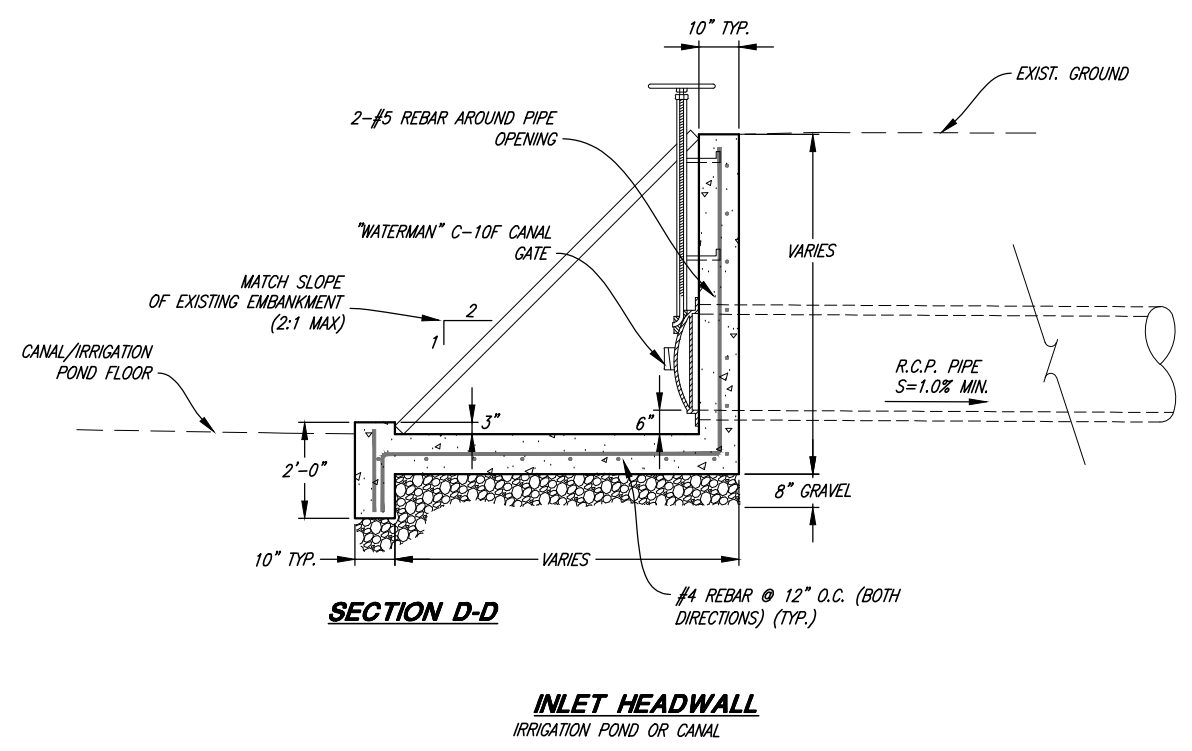
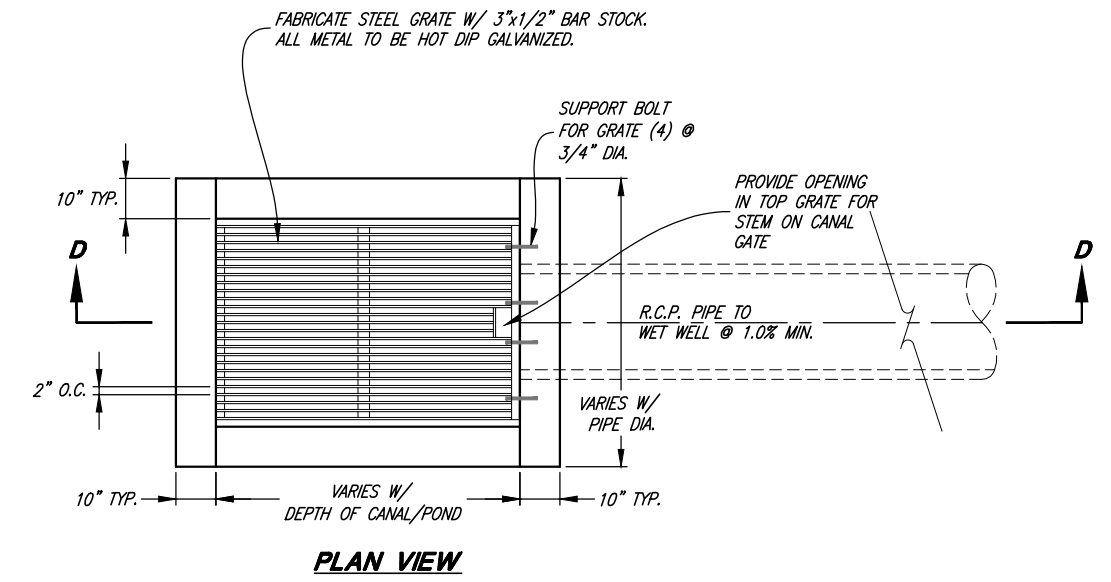
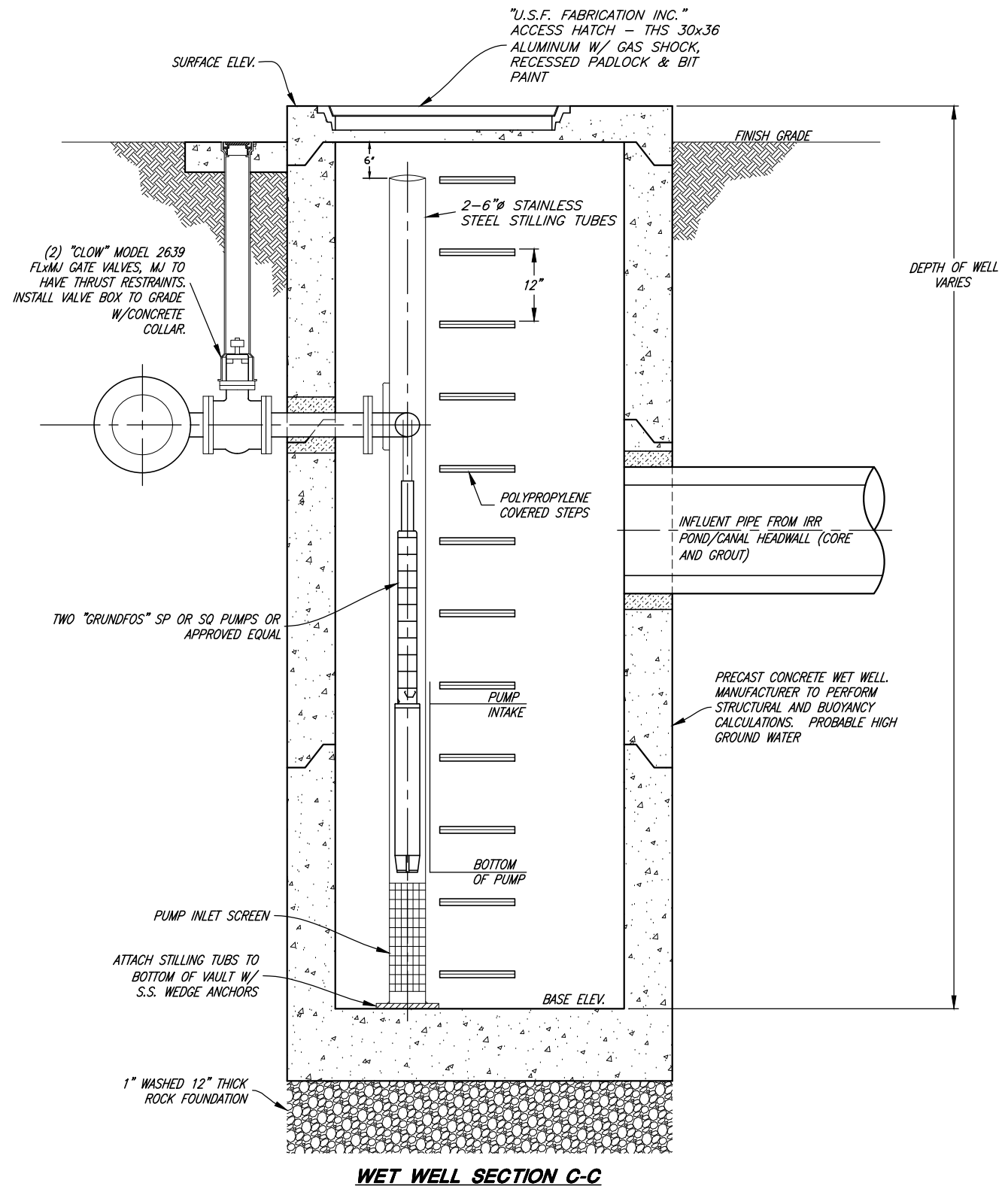

PROJECT ENGINEER	REV.	DATE	APPR.
DATE			

SCALE:
N.T.S.

DESIGNED _____
DRAWN _____
CHECKED _____

JA
JONES & ASSOCIATES

CONSULTING ENGINEERS
6080 Fashion Point Drive
South Ogden, Utah 84403 (801) 476-9767
www.jonescivil.com

HARRISVILLE CITY CORPORATION
PUBLIC WORKS STANDARDS

SECONDARY WATER - PUMP CONTROL & FILTER STATION DETAILS

SHEET:
CS-16b
OF SHEETS
0

SECTION 20

SECONDARY WATER SYSTEMS

- 20.1 GENERAL: This specification covers the general construction requirements for secondary water systems that will be owned and maintained by the City. Design and construction shall be in accordance with this section.
- 20.2 DESIGN: All secondary water systems and calculation shall be reviewed and approved by the City Engineer. It is the developer's responsibility to submit all information relevant to the design of the basin to the City engineer for review and approval. If omission of relevant information effects a change in design, it will be the developer's responsibility to make any necessary modifications to the design and construction.

All aspects of secondary water systems shall be addressed in the design and construction of the system including: Water Rights and Shares; Water Source; Storage Reservoirs; Distribution Pipes; and Service Connections.

A. DEFINITIONS:

1. **Irrigation Season**- The irrigation season shall span from April 15, to October 15 (183 days) or as otherwise dictated by the supplying ditch company
2. **Secondary Water System** - A system comprised of, but not limited to: water shares, diversion structures, conveyance ditches and structures, reservoirs, filters, wet wells, pumps, distribution piping, laterals, drains, and air/vacs valves. From the isolation valve at an individual connection, the responsibility becomes that of the private water user.
3. **Storage Reservoir** - Equalization reservoir used to store water for purposes of pressurized irrigation. Filtration into the reservoir may not be considered unless properly filed upon with the State.
4. **Water Rights** - The right of the ditch company, granted by the State Engineer, to use water. Said right is permitted to the end users through shares. A delivery area, type of use, and point of diversion is associated with the right. Any use outside of the delivery area or type of use require a change with the State Engineer.
5. **Water Share** - Portion of water, granted by the ditch company, for a user to use water. This amount varies by company. The actual flow quantity per share is calculated by dividing the Gross amount of irrigation water given in the water rights by the number of shares in the company.

B. SECONDARY WATER SYSTEM REQUIRED: It is the policy of the City to require pressurized secondary water for all subdivisions within the City. This may be accomplished with either an Secondary Water system or connecting to a system already in place, as determined feasible by the City Engineer.

C. WATER QUANTITY, SHARES AND RIGHTS State Division of Water Rights currently requires the duty of 4.0 Acre feet of water for each acre in the Marriott-Slaterville City area. This amount must be deeded with the recordation of the Final Plat

to the City through ditch shares from the serving ditch company for the property to be irrigated.

As there are different ditch companies within the community, the following table summarizes the share quantity for various ditch companies within Marriott-Slaterville City.

Ditch Company	Acre footage/share/time
Marriott Irrigation Company	1 share = 2.9 ac*ft/year (4/6/05)
Mount Holley Ditch Company	1 share =
North Slaterville Irrigation Co.	1 share = 5.36 ac*ft/year
Perry Ditch Company	1 share =
Warren Irrigation Company	1 share =
Western Canal	1 share = 0.3 ac*ft

- D. **OWNERSHIP:** Ownership of the system shall be deeded to the City with the Final Plat dedication. Certificates of water shares must be included. Upon final completion of the system and final acceptance, the system will be owned maintained and operated by the City unless otherwise previously agreed upon.

Ownership of the City's portion terminates at the corporation stop on the main. Laterals are the property are responsibility of the property owner from the corp stop on the main, through the street and into the property.

- E. **WATER SOURCE:** Ditches or pipes must be provided to insure that water will be able to reach the reservoir from the source. If water is dependent upon a particular share to be received at a particular time, then electronic actuators and gates may be required in order to receive the water without the employ of a person to manually open a gate. The requirement for electronic actuators and gates shall be determined by the City Engineer.

Adequate flow to have adequate storage for pressure irrigation between water turns must be obtained from the source. As a minimum, the average flow of **6.0 g.p.m. per irrigable acre** is required. This equates to 0.0134 cfs/irrigable acre or 4.85 Acft/yr/irrigable acre (183 days per year). Irrigable acres are used for this calculation. **Peak Instantaneous Flow** for pump sizing and distribution pipes is discussed later.

- F. **WATER STORAGE:** As water turns on ditches vary, reservoirs must be sized to hold a minimum of one week supply of water for the entire system at build out. As a minimum, **1 Acre- foot of storage is required for 50 acres of irrigable land per day.** Unless previously approved by the City Engineer, secondary water shall always be separated from storm drain water. *Caution must be taken in implementing this information for system filled once per week once numbers are given based upon a daily*

demand. The storage amount given herein correlates with Pine View Water System requirements. This is done so that if a transfer ever takes place, the system will comply.

1. **Fencing:** Reservoirs should be fenced around the perimeter with room between the fence and the perimeter for maintenance vehicles (min 20'). Fencing shall be 6 feet tall chain link in accordance with these Public Works Standards and conform to City Zoning requirements.
2. **Lining:** Reservoirs shall be clay lined to inhibit percolation or infiltration. The corners should be rounded to avoid stress concentrations in the event of future concrete lining.
3. **Side Slope:** Due to the fact that most of these basins will be in residential areas, the maximum side slope of the basin shall be two (2) feet horizontal to one (1) foot vertical.
4. **Depth:** Irrigation basins shall not exceed 12 feet deep and, in the presence of ground water, consideration for draining the basin must be given.
5. **Grates, Pipes and Screens:** All grates and screens shall be hot dip galvanized to avoid corrosion. Pipes shall be in accordance with the pipe specification given herein.
6. **Freeboard:** The top of the embankment in all areas shall be one (1) foot above the highest water elevation.
7. **Ground Covers:** The surface area around the basin shall be covered with weed barrier fabric and gravel. Gravel shall be 2" minus and be 4" thick over the top of the weed barrier.
8. **Embankment (Fill) Construction:** If a raised embankment is constructed for the reservoir (constructed with granular materials), it shall be provided with a minimum of 6" of clay cover on the inside of the berm to prevent water passage through the soil as well as the clay lining.
9. **Excavation (Cut) Construction:** If the basin is constructed primarily by excavation, then it may be necessary to provide an impermeable liner and land drain system when constructed in the proximity of basements or other below grade structures as determined by a geotechnical evaluation.

G. PRESSURIZATION

Gravity systems are always desirable, however pumps may need to be used. Pumps, which shall directly pressurize the system, shall be Variable Frequency Drive (VFD) pumps with redundancy designed for meeting the peak instantaneous flows.

The hydraulics of the system should be set for a peak instantaneous flow equal to the following formula:

$$Q = U * 180 * N^{0.55}$$

Where: Q is the instantaneous flow rate in g.p.m.
U is the usage factor (no less than 60% or 0.6)
N is the total number of Irrigable acres

In no case shall the Peak Instantaneous Flow Rate per irrigable acre be less than 8gpm. Pressures should be designed between 60 psi (139' TDH) and 100 psi (230' TDH). Pump

curves shall be submitted to the City along with the Operation and Maintenance Manual for the Pump. Velocities in the pipes shall not exceed 4 feet per second during peak instantaneous demand. A minimum of two pumps must be installed in order to accommodate redundancy and low flows. A Variable Frequency Drive system shall be included to handle the above flows and pressures.

Housing of the pumps may be permitted below grade depending upon the local conditions. Transformers, power meters, panels and controls must be above grade in weather proof, vandal resistant shed mounted on a concrete pad as specified within these specifications.

Self cleaning trash rack shall be provided at the inlet to the pump or wet well. An "Amiad" brand automatic filter for the system must be installed and properly drained.

Security fencing, shall be provided around the reservoir and pump system in accordance with the fencing standards.

H. DISTRIBUTION: The Distribution systems shall be sized in accordance with the above criteria to meet flows, quality and quantities as given in the above criteria.

1. **Piping:** The minimum water main size shall be 6" diameter. All pipes from 6" to 10" may be PVC class 200 pipe. Pipes 12" or greater shall be PVC C905 DR25. Joints shall be bell & spigot. Fittings shall be ductile iron Class 150 Mechanical Joint. Consideration must be given for corrosive soils. Purple pigment is required for all sizes. A depth between 3 and 5 feet should be allowed. Consideration shall be made for gravity draining of mainlines to a drain valve. 3" metallic locator tape shall be installed 12" above all PVC piping.
2. **Laterals:** Service must be provided to each lot. Single laterals shall be 1" sized. A common 1 ½" minimum sized service may be supplied to a common lot with a tee to both lots and separate shut off valves. Lateral material shall be Polyethylene (PE) 200 psi Copper Tubing Size (CTS) Poly with metallic locator tape. The depth of the lateral shall not be less than 24", and no more than 48".
3. **Filter:** No filter is required on the individual residential laterals.
4. **Meters:** No meter is required on the individual residential laterals.
5. **Meter Box:** Meter boxes shall be Plastic Brooks 1419 Series Utility Box with recessed standard Waterworks pentagon head locking device. Top of lid to be labeled "Irrigation"
6. **Valves:** Main line valves shall be Resilient Seat Gate Valves installed at the extension of property lines in locations specified by the City Engineer. Concrete collar around cast iron valve boxes shall be installed.
7. **Drains:** Drains must be installed to a storm drain at low spots on the system. Details for the drain valves, manholes, rings and covers are given in the Standard Drawings.
8. **Air/vac Valves:** Air/vac valves shall be installed no more than at a 1000 foot spacing and at high points so that pipes don't collapse during drainage. Details for the Air/vac valves, manholes, rings and covers are given in the Standard Drawings.

- 20.3 EXECUTION: Construction of these items shall be done in accordance with this specification or the manufacturers specifications.
- 20.4 GUARANTEE: The contractor shall be responsible for the protection of all facilities until acceptance by the owner. This guarantee shall include the repair or calibration of any components during the guarantee period.

APPENDIX C

Head / Headloss Curves

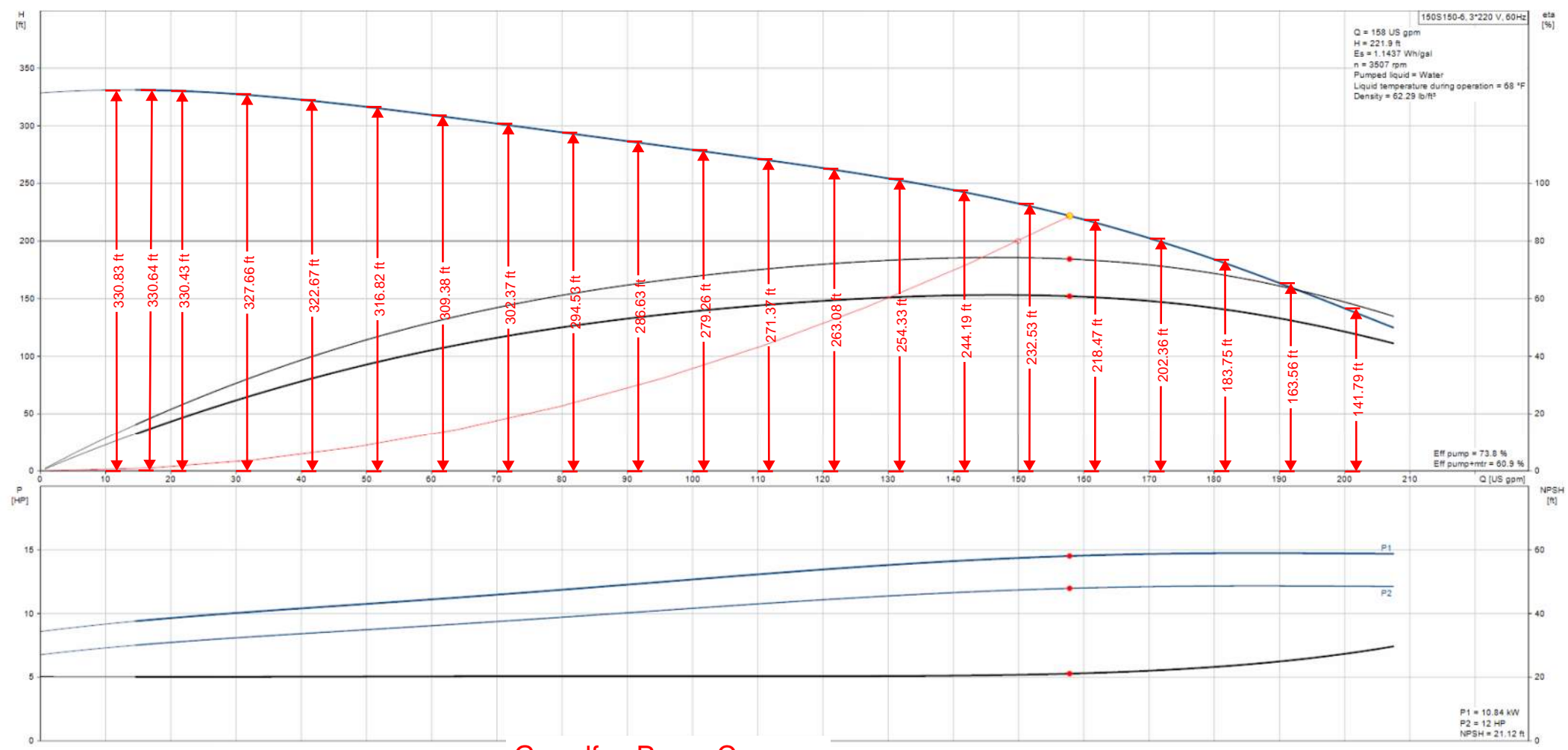

**Grundfos Pump Curve
(100% Speed)**



PROPELLER METERS ACCURACY AND HEAD LOSS CURVES



3255 WEST STETSON AVENUE • HEMET, CALIFORNIA 92545 USA • TEL: 951-652-6811 • FAX: 951-652-3078
Visit our Website: www.mccrometer.com

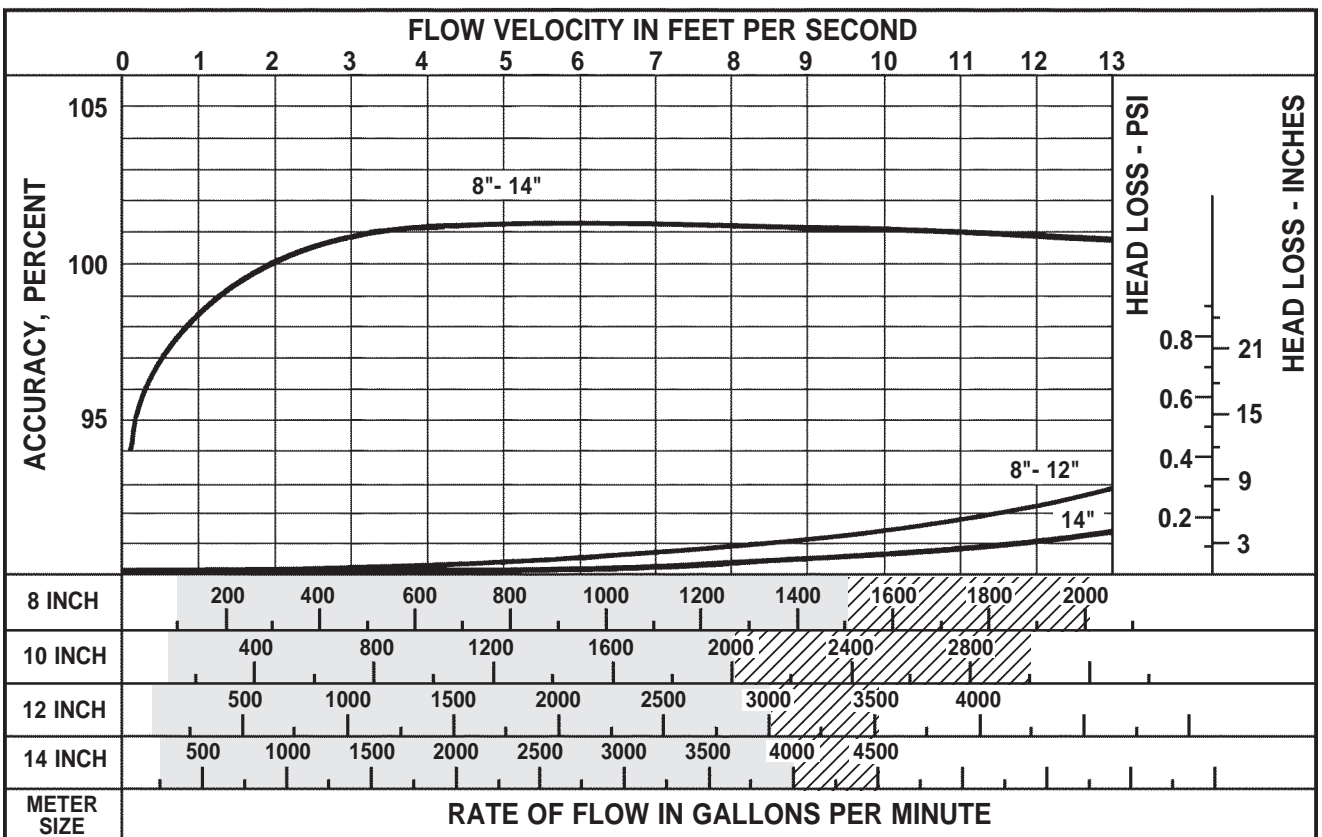
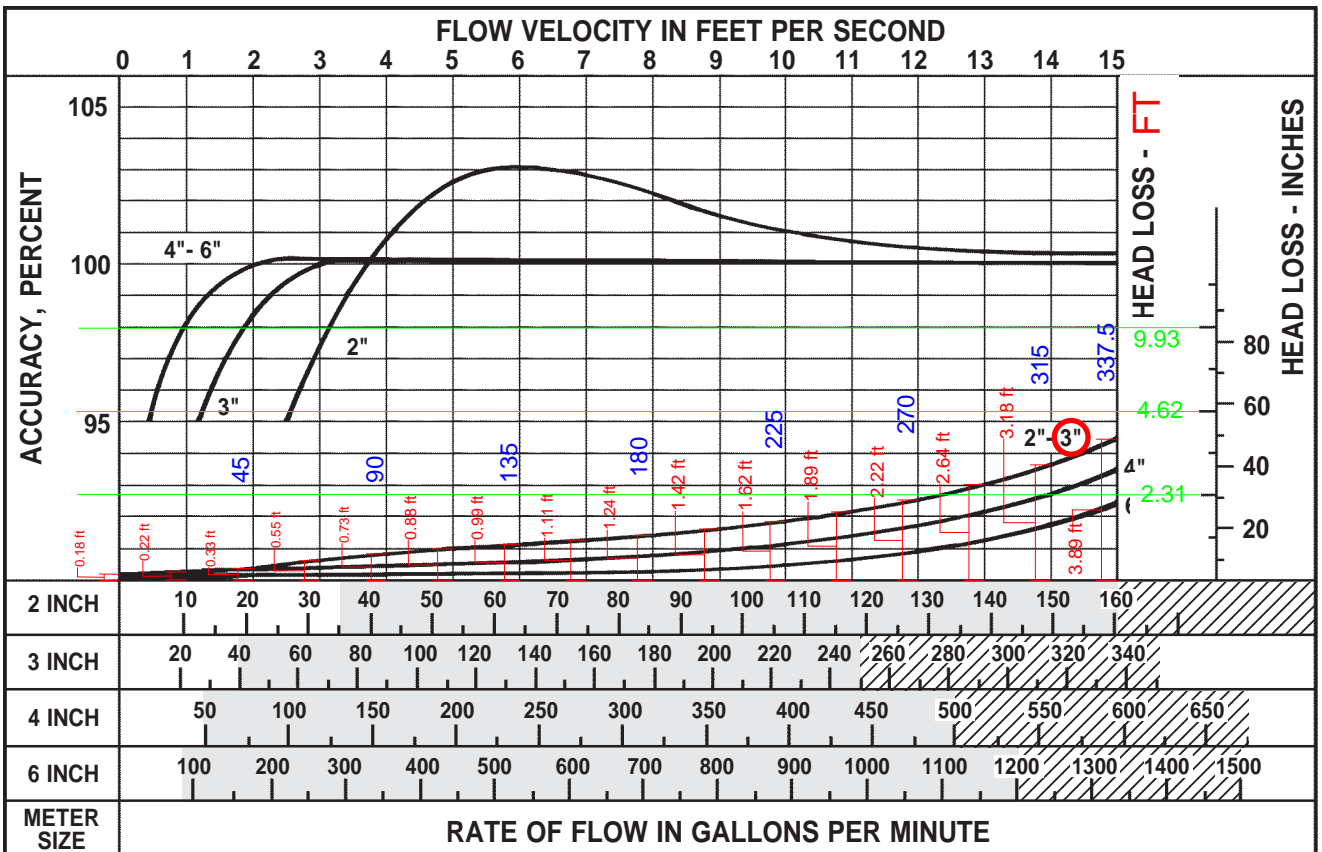

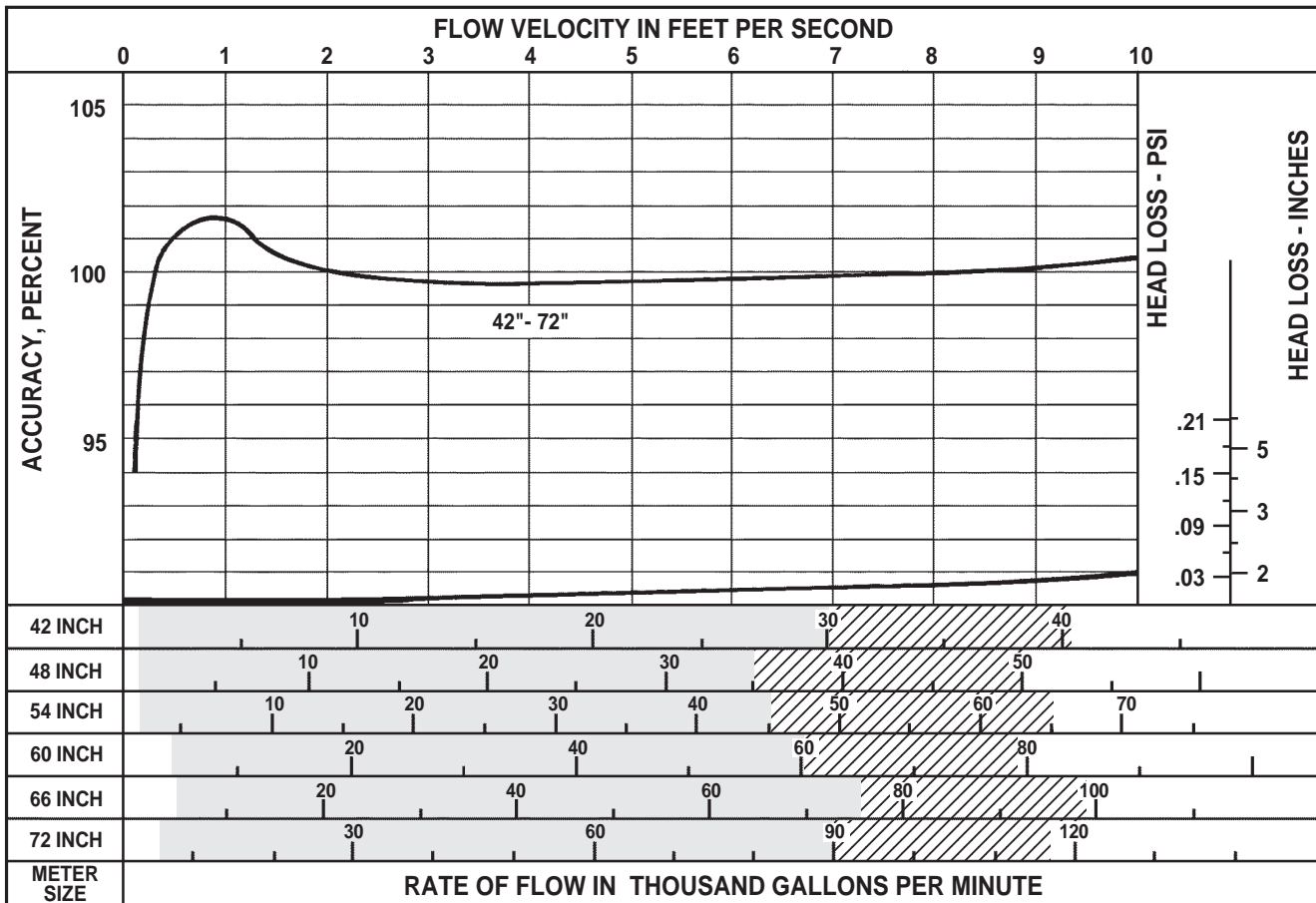
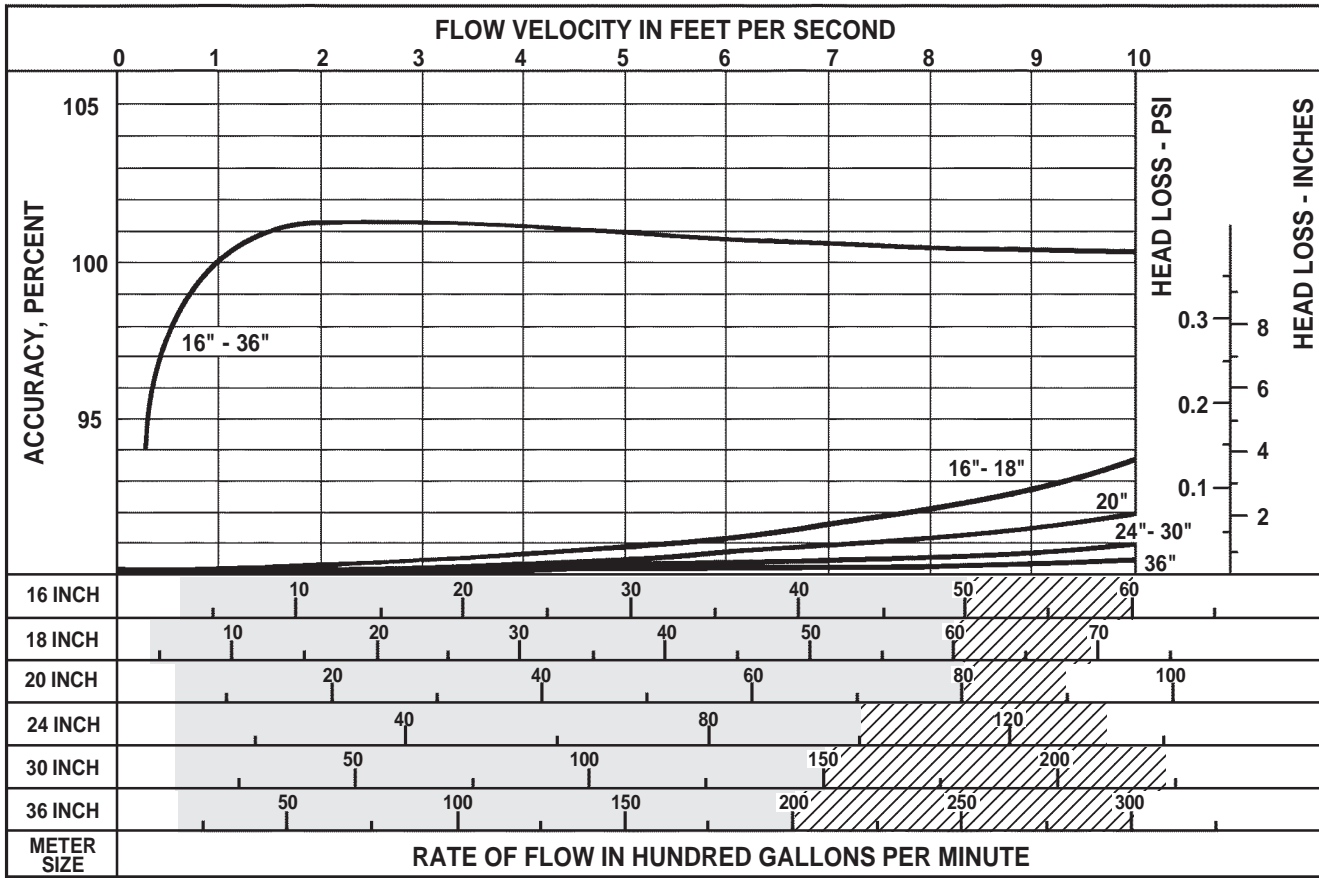

MAXIMUM AND MINIMUM FLOWS

INTERMITTENT FLOWS

APPENDIX D

Model Results

Peak Flow Odd Numbered Lots.

Network Table - Nodes

Node ID	Elevation ft	Base Demand GPM	Head ft	Pressure psi
Junc 1	4220	0	4219.60	-0.17
Junc 3	4221	0	4431.36	91.15
Junc m4	4221	0	4429.36	90.28
Junc m5	4221	0	4428.90	90.08
Junc 204	4223	0	4423.85	87.03
Junc 203	4223	36	4406.94	79.70
Junc m6	4221	0	4428.66	89.98
Junc 210	4223	0	4425.96	87.94
Junc 211	4223	36	4409.04	80.61
Junc m7	4221	0	4428.46	89.89
Junc 205	4223	36	4406.49	79.51
Junc 206	4223	0	4423.41	86.84
Junc m8	4222	0	4428.31	89.39
Junc g	4222	0	4425.61	88.22
Junc 208	4224	0	4425.61	87.36
Junc 209	4224	36	4408.69	80.03
Junc m9	4222	0	4428.25	89.37
Junc h	4222	0	4410.03	81.47
Junc OS_E	4225	36	4359.29	58.19
Junc 207	4225	36	4393.12	72.84
Junc f	4222	0	4423.41	87.27
Junc e	4221	0	4425.96	88.81
Junc d	4221	0	4423.85	87.90
Junc m3	4221	0	4429.24	90.23
Junc c	4221	0	4426.54	89.06

Peak Flow Odd Numbered Lots.

Node ID	Elevation ft	Base Demand GPM	Head ft	Pressure psi
Junc 212	4223	0	4426.54	88.19
Junc 213	4223	36	4409.62	80.86
Junc m2	4221	0	4429.19	90.21
Junc b	4221	0	4424.15	88.02
Junc 202	4224	0	4424.15	86.72
Junc 201	4224	36	4407.23	79.39
Junc m1	4220.6	0	4429.18	90.38
Junc a	4221	0	4426.48	89.03
Junc 214	4224	0	4426.48	87.73
Junc 215	4224	36	4409.56	80.40
Junc 2	4221	0	4434.83	92.65
Resvr POND	4220	#N/A	4220.00	0.00

Peak Flow Odd Numbered Lots.

Network Table - Links

Link ID	Length ft	Diameter in	Flow GPM	Velocity fps
Pipe P13	20	1	36.00	14.71
Pipe P12	20	1	0.00	0.00
Pipe P3	20	1	36.00	14.71
Pipe P4	20	1	0.00	0.00
Pipe P15	20	1	36.00	14.71
Pipe P14	20	1	0.00	0.00
Pipe P1	20	1	36.00	14.71
Pipe P2	20	1	0.00	0.00
Pipe P9	20	1	36.00	14.71
Pipe P8	20	1	0.00	0.00
Pipe P7	20	1	36.00	14.71
Pipe P-OS_E	60	1	36.00	14.71
Pipe P11	20	1	36.00	14.71
Pipe P10	20	1	0.00	0.00
Pipe P5	20	1	36.00	14.71
Pipe P6	20	1	0.00	0.00
Pipe Lc	23	1.5	36.00	6.54
Pipe Lb	43	1.5	36.00	6.54
Pipe La	23	1.5	36.00	6.54
Pipe Lh	43	1.5	72.00	13.07
Pipe Lf	43	1.5	36.00	6.54
Pipe Lg	23	1.5	36.00	6.54
Pipe L6	23	1.5	36.00	6.54
Pipe Ld	43	1.5	36.00	6.54
Pipe M_5	89	6	180.01	2.04

Peak Flow Odd Numbered Lots.

Link ID	Length ft	Diameter in	Flow GPM	Velocity fps
Pipe M_6	113	6	144.01	1.63
Pipe 1	50	6	324.02	3.68
Pipe 2	250	6	324.02	3.68
Pipe M_4	122	6	216.01	2.45
Pipe M_1	112	6	36.00	0.41
Pipe M_2	91	6	72.01	0.82
Pipe M_3	117	6	108.01	1.23
Pipe M_7	142	6	108.00	1.23
Pipe M_8	114	6	72.00	0.82
Valve Meter	#N/A	8	324.02	2.07
Pump Pump-2	#N/A	#N/A	162.01	0.00
Pump Pump-1	#N/A	#N/A	162.01	0.00

Average Flow Odd Numbered Lots.

Network Table - Nodes

Node ID	Elevation ft	Base Demand GPM	Head ft	Pressure psi
Resvr POND	4220	#N/A	4220.00	0.00
Junc 1	4220	0	4220.00	0.00
Junc m1	4220.6	0	4403.72	79.34
Junc m3	4221	0	4403.72	79.17
Junc c	4221	0	4403.70	79.16
Junc m7	4221	0	4403.71	79.17
Junc 2	4221	0	4403.96	79.28
Junc e	4221	0	4403.69	79.16
Junc d	4221	0	4403.68	79.15
Junc m5	4221	0	4403.72	79.17
Junc m4	4221	0	4403.72	79.17
Junc 3	4221	0	4403.73	79.18
Junc a	4221	0	4403.70	79.16
Junc b	4221	0	4403.68	79.15
Junc m2	4221	0	4403.72	79.17
Junc m6	4221	0	4403.71	79.17
Junc f	4222	0	4403.67	78.72
Junc h	4222	0	4403.57	78.67
Junc m8	4222	0	4403.71	78.74
Junc g	4222	0	4403.69	78.73
Junc m9	4222	0	4403.71	78.74
Junc 213	4223	2.6	4403.57	78.24
Junc 211	4223	2.6	4403.56	78.24
Junc 210	4223	0	4403.69	78.29
Junc 203	4223	2.6	4403.55	78.23

Average Flow Odd Numbered Lots.

Node ID	Elevation ft	Base Demand GPM	Head ft	Pressure psi
Junc 204	4223	0	4403.68	78.29
Junc 206	4223	0	4403.67	78.29
Junc 205	4223	2.6	4403.54	78.23
Junc 212	4223	0	4403.70	78.30
Junc 209	4224	2.6	4403.56	77.80
Junc 214	4224	0	4403.70	77.86
Junc 215	4224	2.6	4403.57	77.81
Junc 202	4224	0	4403.68	77.85
Junc 201	4224	2.6	4403.55	77.80
Junc 208	4224	0	4403.69	77.86
Junc 207	4225	2.6	4403.44	77.32
Junc OS_E	4225	2.6	4403.18	77.21

Average Odd Numbered Lots.

Network Table - Links

Link ID	Length ft	Diameter in	Flow GPM	Velocity fps
Pipe P13	20	1	2.60	1.06
Pipe P12	20	1	0.00	0.00
Pipe P3	20	1	2.60	1.06
Pipe P2	20	1	0.00	0.00
Pipe P15	20	1	2.60	1.06
Pipe P14	20	1	0.00	0.00
Pipe P1	20	1	2.60	1.06
Pipe P4	20	1	0.00	0.00
Pipe P9	20	1	2.60	1.06
Pipe P8	20	1	0.00	0.00
Pipe P7	20	1	2.60	1.06
Pipe P6	20	1	0.00	0.00
Pipe P11	20	1	2.60	1.06
Pipe P10	20	1	0.00	0.00
Pipe P5	20	1	2.60	1.06
Pipe Lc	23	1.5	2.60	0.47
Pipe La	23	1.5	2.60	0.47
Pipe Lg	23	1.5	2.60	0.47
Pipe L6	23	1.5	2.60	0.47
Pipe Lh	43	1.5	38.60	7.01
Pipe Lb	43	1.5	2.60	0.47
Pipe Ld	43	1.5	2.60	0.47
Pipe Lf	43	1.5	2.60	0.47
Pipe l	50	6	56.83	0.64
Pipe P-OS_E	60	1	36.00	14.71

Average Odd Numbered Lots.

Link ID	Length ft	Diameter in	Flow GPM	Velocity fps
Pipe M_5	89	6	46.41	0.53
Pipe M_2	91	6	5.21	0.06
Pipe M_1	112	6	2.60	0.03
Pipe M_6	113	6	43.81	0.50
Pipe M_8	114	6	38.60	0.44
Pipe M_3	117	6	7.81	0.09
Pipe M_4	122	6	49.01	0.56
Pipe M_7	142	6	41.20	0.47
Pipe 2	250	6	56.83	0.64
Valve Meter	#N/A	8	56.83	0.36
Pump Pump-2	#N/A	#N/A	28.41	0.00
Pump Pump-1	#N/A	#N/A	28.41	0.00

Peak Flow for Even Numbered Lots.

Network Table - Nodes

Node ID	Elevation ft	Base Demand GPM	Head ft	Pressure psi
Resvr POND	4220	#N/A	4220.00	0.00
Junc 1	4220	0	4219.60	-0.17
Junc m1	4220.6	0	4429.13	90.35
Junc m3	4221	0	4429.20	90.21
Junc c	4221	0	4425.84	88.76
Junc m7	4221	0	4428.60	89.95
Junc 2	4221	0	4434.82	92.65
Junc e	4221	0	4425.39	88.56
Junc d	4221	0	4422.67	87.38
Junc m5	4221	0	4428.94	90.10
Junc m4	4221	0	4429.35	90.28
Junc 3	4221	0	4431.36	91.15
Junc a	4221	0	4425.77	88.73
Junc b	4221	0	4422.87	87.47
Junc m2	4221	0	4429.14	90.19
Junc m6	4221	0	4428.75	90.02
Junc f	4222	0	4422.32	86.80
Junc h	4222	0	4422.21	86.75
Junc m8	4222	0	4428.51	89.48
Junc g	4222	0	4425.15	88.03
Junc m9	4222	0	4428.49	89.47
Junc 213	4223	00	4425.84	87.89
Junc 211	4223	0	4425.39	87.69
Junc 210	4223	40.5	4404.35	78.58
Junc 203	4223	0	4422.67	86.52

Peak Flow for Even Numbered Lots.

Node ID	Elevation ft	Base Demand GPM	Head ft	Pressure psi
Junc 204	4223	40.5	4401.63	77.40
Junc 206	4223	40.5	4401.28	77.25
Junc 205	4223	0	4422.32	86.37
Junc 212	4223	40.5	4404.80	78.78
Junc 209	4224	0	4425.15	87.16
Junc 214	4224	40.5	4404.73	78.31
Junc 215	4224	0	4425.77	87.43
Junc 202	4224	40.5	4401.83	77.05
Junc 201	4224	0	4422.87	86.17
Junc 208	4224	40.5	4404.11	78.04
Junc 207	4225	0	4422.21	85.45
Junc OS_E	4225	40.5	4359.10	58.10

Peak Flow for Even Numbered Lots.

Network Table - Links

Link ID	Length ft	Diameter in	Flow GPM	Velocity fps
Pipe P13	20	1	0.00	0.00
Pipe P12	20	1	40.50	16.54
Pipe P3	20	1	0.00	0.00
Pipe P2	20	1	40.50	16.54
Pipe P15	20	1	0.00	0.00
Pipe P14	20	1	40.50	16.54
Pipe P1	20	1	0.00	0.00
Pipe P4	20	1	40.50	16.54
Pipe P9	20	1	0.00	0.00
Pipe P8	20	1	40.50	16.54
Pipe P7	20	1	0.00	0.00
Pipe P6	20	1	40.50	16.54
Pipe P11	20	1	0.00	0.00
Pipe P10	20	1	40.50	16.54
Pipe P5	20	1	0.00	0.00
Pipe Lc	23	1.5	40.50	7.35
Pipe La	23	1.5	40.50	7.35
Pipe Lg	23	1.5	40.50	7.35
Pipe L6	23	1.5	40.50	7.35
Pipe Lh	43	1.5	40.50	7.35
Pipe Lb	43	1.5	40.50	7.35
Pipe Ld	43	1.5	40.50	7.35
Pipe Lf	43	1.5	40.50	7.35
Pipe l	50	6	324.03	3.68
Pipe P-OS_E	60	1	40.50	16.54

Peak Flow for Even Numbered Lots.

Link ID	Length ft	Diameter in	Flow GPM	Velocity fps
Pipe M_5	89	6	162.01	1.84
Pipe M_2	91	6	81.01	0.92
Pipe M_1	112	6	40.50	0.46
Pipe M_6	113	6	121.51	1.38
Pipe M_8	114	6	40.50	0.46
Pipe M_3	117	6	121.51	1.38
Pipe M_4	122	6	202.52	2.30
Pipe M_7	142	6	81.01	0.92
Pipe 2	250	6	324.03	3.68
Valve Meter	#N/A	8	324.03	2.07
Pump Pump-2	#N/A	#N/A	162.01	0.00
Pump Pump-1	#N/A	#N/A	162.01	0.00

Average Flow for Even Numbered Lots.

Network Table - Nodes

Node ID	Elevation ft	Base Demand GPM	Head ft	Pressure psi
Resvr POND	4220	#N/A	4220.00	0.00
Junc 1	4220	0	4220.00	0.00
Junc m1	4220.6	0	4403.74	79.36
Junc m3	4221	0	4403.74	79.18
Junc c	4221	0	4403.72	79.17
Junc m7	4221	0	4403.74	79.18
Junc 2	4221	0	4403.98	79.29
Junc e	4221	0	4403.71	79.17
Junc d	4221	0	4403.69	79.16
Junc m5	4221	0	4403.74	79.18
Junc m4	4221	0	4403.74	79.18
Junc 3	4221	0	4403.76	79.19
Junc a	4221	0	4403.72	79.17
Junc b	4221	0	4403.69	79.16
Junc m2	4221	0	4403.74	79.18
Junc m6	4221	0	4403.74	79.18
Junc f	4222	0	4403.69	78.73
Junc h	4222	0	4403.69	78.73
Junc m8	4222	0	4403.74	78.75
Junc g	4222	0	4403.71	78.74
Junc m9	4222	0	4403.74	78.75
Junc 213	4223	00	4403.72	78.30
Junc 211	4223	0	4403.71	78.30
Junc 210	4223	2.92	4403.55	78.23
Junc 203	4223	0	4403.69	78.29

Average Flow for Even Numbered Lots.

Node ID	Elevation ft	Base Demand GPM	Head ft	Pressure psi
Junc 204	4223	2.92	4403.53	78.22
Junc 206	4223	2.92	4403.53	78.22
Junc 205	4223	0	4403.69	78.29
Junc 212	4223	2.92	4403.56	78.23
Junc 209	4224	0	4403.71	77.87
Junc 214	4224	2.92	4403.55	77.80
Junc 215	4224	0	4403.72	77.87
Junc 202	4224	2.92	4403.53	77.79
Junc 201	4224	0	4403.69	77.86
Junc 208	4224	2.92	4403.55	77.80
Junc 207	4225	0	4403.69	77.43
Junc OS_E	4225	2.92	4403.20	77.22

Average Flow for Even Numbered Lots.

Network Table - Links

Link ID	Length ft	Diameter in	Flow GPM	Velocity fps
Pipe P13	20	1	0.00	0.00
Pipe P12	20	1	2.92	1.19
Pipe P3	20	1	0.00	0.00
Pipe P2	20	1	2.92	1.19
Pipe P15	20	1	0.00	0.00
Pipe P14	20	1	2.92	1.19
Pipe P1	20	1	0.00	0.00
Pipe P4	20	1	2.92	1.19
Pipe P9	20	1	0.00	0.00
Pipe P8	20	1	2.92	1.19
Pipe P7	20	1	0.00	0.00
Pipe P6	20	1	2.92	1.19
Pipe P11	20	1	0.00	0.00
Pipe P10	20	1	2.92	1.19
Pipe P5	20	1	0.00	0.00
Pipe Lc	23	1.5	2.92	0.53
Pipe La	23	1.5	2.92	0.53
Pipe Lg	23	1.5	2.92	0.53
Pipe L6	23	1.5	2.92	0.53
Pipe Lh	43	1.5	2.92	0.53
Pipe Lb	43	1.5	2.93	0.53
Pipe Ld	43	1.5	2.92	0.53
Pipe Lf	43	1.5	2.92	0.53
Pipe l	50	6	23.36	0.27
Pipe P-OS_E	60	1	2.92	1.19

Average Flow for Even Numbered Lots.

Link ID	Length ft	Diameter in	Flow GPM	Velocity fps
Pipe M_5	89	6	11.68	0.13
Pipe M_2	91	6	5.84	0.07
Pipe M_1	112	6	2.92	0.03
Pipe M_6	113	6	8.76	0.10
Pipe M_8	114	6	2.92	0.03
Pipe M_3	117	6	8.76	0.10
Pipe M_4	122	6	14.60	0.17
Pipe M_7	142	6	5.84	0.07
Pipe 2	250	6	23.36	0.27
Valve Meter	#N/A	8	23.36	0.15
Pump Pump-2	#N/A	#N/A	0.00	0.00
Pump Pump-1	#N/A	#N/A	23.36	0.00

APPENDIX E

Pump and Meter O&M Manuals

SP

Stainless steel submersible pumps 4", 6", 8", and 10"

Installation and operating instructions



Original installation and operating instructions

CONTENTS

	Page
1. Limited warranty	3
2. Symbols used in this document	3
3. Product description	4
3.1 Introduction	4
3.2 Applications	4
3.3 Features and benefits	4
3.4 Type key	4
4. Delivery, handling and storage	4
4.1 Delivery	4
4.2 Handling	4
4.3 Storage	5
5. Operating conditions	5
6. Installation	5
6.1 Pre-installation checklist	5
6.2 Positional requirements	6
6.3 Preparation	7
6.4 Removing and fitting the cable guard	9
6.5 Splicing the motor cable	9
6.6 Riser pipe	10
6.7 Electrical and variable-frequency drive information	12
7. Startup	20
7.1 Startup with three-phase motors	20
8. Operation	22
8.1 Minimum flow rate	22
8.2 Soft starter	23
8.3 Maintenance and service	23
9. Troubleshooting	23
9.1 Preliminary tests	24
9.2 Checking pump performance	25
9.3 Troubleshooting chart	26
10. Technical data	30
10.1 Motor cooling requirements	30
10.2 Guide for engine-driven generators in submersible pump applications	31
10.3 Transformer capacity required for three-phase submersible motors	32
10.4 Submersible drop cable selection charts (60 Hz)	32
10.5 Approvals	38
10.6 Electrical data	39
11. Disposal	42

WARNING

Prior to installation, read these installation and operating instructions. Installation and operation must comply with local regulations and accepted codes of good practice.

Keep this booklet with the pump for future reference and information regarding its operation.

WARNING

The installation of this product requires experience with and knowledge of the product.

Persons with reduced physical, sensory or mental capabilities must not use this product, unless they are under supervision or have been instructed in the use of the product by a person responsible for their safety. Children must not use or play with this product.

1. Limited warranty

Products manufactured by GRUNDFOS PUMPS CORPORATION (Grundfos) are warranted to the original user only to be free of defects in material and workmanship for a period of 24 months from date of installation, but not more than 30 months from date of manufacture.

Grundfos' liability under this warranty shall be limited to repairing or replacing at Grundfos' option, without charge, FOB Grundfos' factory or authorized service station, any product of Grundfos' manufacture. Grundfos will not be liable for any costs of removal, installation, transportation, or any other charges which may arise in connection with a warranty claim.

Products which are sold but not manufactured by Grundfos are subject to the warranty provided by the manufacturer of said products and not by Grundfos' warranty. Grundfos will not be liable for damage or wear to products caused by abnormal operating conditions, accident, abuse, misuse, unauthorized alteration or repair, or if the product was not installed in accordance with Grundfos' printed installation and operating instructions.

To obtain service under this warranty, the defective product must be returned to the distributor or dealer of Grundfos' products from which it was purchased together with proof of purchase and installation date, failure date, and supporting installation data. Unless otherwise provided, the distributor or dealer will contact Grundfos or an authorized service station for instructions. Any defective product to be returned to Grundfos or a service station must be sent freight prepaid; documentation supporting the warranty claim and/or a Return Material Authorization must be included if so instructed.

GRUNDFOS WILL NOT BE LIABLE FOR ANY INCIDENTAL OR CONSEQUENTIAL DAMAGES, LOSSES, OR EXPENSES ARISING FROM INSTALLATION, USE, OR ANY OTHER CAUSES. THERE ARE NO EXPRESS OR IMPLIED WARRANTIES, INCLUDING MERCHANTABILITY OR FITNESS FOR A PARTICULAR PURPOSE, WHICH EXTEND BEYOND THOSE WARRANTIES DESCRIBED OR REFERRED TO ABOVE.

Some jurisdictions do not allow the exclusion or limitation of incidental or consequential damages and some jurisdictions do not allow limit actions on how long implied warranties may last. Therefore, the above limitations or exclusions may not apply to you. This warranty gives you specific legal rights and you may also have other rights which vary from jurisdiction to jurisdiction.

2. Symbols used in this document



WARNING

If these safety instructions are not observed, it may result in personal injury.



WARNING

If these instructions are not observed, it may lead to electric shock with consequent risk of serious personal injury or death.

CAUTION

Caution

If these safety instructions are not observed, it may result in malfunction or damage to the equipment.

Note

Notes or instructions that make the job easier and ensure safe operation.

3. Product description

3.1 Introduction

Your Grundfos SP submersible pump is of the highest quality. Combined with proper installation, your Grundfos pump will give you many years of reliable service.

To ensure the proper installation of the pump, carefully read the complete manual before attempting to install the pump.

3.2 Applications

Grundfos SP submersible pumps are suitable for the following applications:

- groundwater supply to waterworks
- irrigation in horticulture and agriculture
- groundwater lowering (dewatering)
- pressure boosting
- industrial applications
- domestic water supply.

3.3 Features and benefits

- State-of-the-art hydraulics provide high efficiency and low operating costs
- 100 % stainless steel components inside and outside for long service life
- sand resistant
- resistant to aggressive water
- monitoring, protection, and communication via protection unit MP 204, and GO remote control.

3.4 Type key

Example	475	S	500	-	5	-	A	B
Rated flow rate in gpm								
Type range								
Stainless steel parts of material								
S = AISI 304								
N = AISI 316								
R = AISI 904L								
Hp of motor								
Number of impellers								
First reduced-diameter impeller (A, B or C)								
Second reduced-diameter impeller (A, B or C)								

4. Delivery, handling and storage

4.1 Delivery

CAUTION

Caution

Keep the pump in the shipping carton until it is placed in the vertical position during installation.

Handle the pump with care.

Examine the components carefully to make sure no damage has occurred to the pump end, motor, cable or control box during shipment.

4.2 Handling

Keep the pump in the shipping carton until it is ready to be installed. The shipping carton is specially designed to protect it from damage. During unpacking and prior to installation, make sure that the pump is not dropped or mishandled.

Do not expose the pump to unnecessary impact and shocks.

The motor is equipped with a power cable.

CAUTION

Caution

Never use the power cable to support the weight of the pump.

You will find a loose nameplate with an adhesive backing with the pump. If the nameplate is blank, complete it in pen and attach it to the control box.

Note

Fix the extra nameplate supplied with the pump at the installation site.

4.3 Storage

4.3.1 Storage temperature

Pump: -4 - +140 °F (-20 - +60 °C).

Motor: -4 - +158 °F (-20 - +70 °C).

Store the motors in a closed, dry and well ventilated room.

CAUTION

Caution

If MMS motors are stored, the shaft must be turned by hand at least once a month. If a motor has been stored for more than one year before installation, the rotating parts of the motor must be dismantled and checked before use.

Do not expose the pump to direct sunlight.

If the pump has been unpacked, store it horizontally, adequately supported, or vertically to prevent misalignment. Make sure that the pump cannot roll or fall over.

During storage, the pump can be supported as shown in fig. 1.

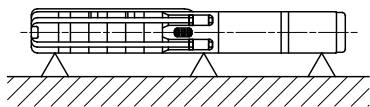

Fig. 1 Pump position during storage

TM00 1349 2495

4.3.2 Frost protection

If the pump has to be stored after use, it must be stored on a frost-free location, or the motor liquid must be frost-proof.

5. Operating conditions

Flow rate, Q:	Up to 1400 gpm (318 m ³ /h)	
Head, H:	Up to 2657 ft (810 m)	
Liquid temperature:	32-140 °F (0-60 °C)	
	MS 402	492 ft (150 m) (213 psi)
Maximum submersible depth:	MS 4000	1969 ft (600 m) (852 psi)
	MS 6000	1969 ft (600 m) (852 psi)
	All MMS	1969 ft (600 m) (852 psi)

6. Installation

Install products in accordance with the local code of the authority having jurisdiction. Installation must be carried out by a qualified person.



WARNING

Risk of electric shock. Do not remove cord and strain relief. Do not connect conduit to pump.

6.1 Pre-installation checklist

Make the following checks before beginning installation:

- condition of the well
- condition of the water
- installation depth
- power supply
- cable type.

These checks are all critical for the proper installation of this submersible pump.

6.1.1 Condition of the well

If the pump is to be installed in a new well, make sure that the well is fully developed and bailed or blown free of cuttings, drillings and sand. The stainless steel construction of the Grundfos submersible pump makes it resistant to abrasion; however, no pump, made of any material, can forever withstand the destructive wear that occurs when constantly pumping sandy water.

If this pump is used to replace an oil-filled submersible or oil-lubricated line-shaft turbine pump in an existing well, the well must be blown or bailed clear of oil.

Determine the maximum depth of the well, and the draw-down level at the pump's maximum capacity. Use this data for pump selection and to determine installation depth.

Check the inside diameter of the well casing to ensure that it is larger than the size of the pump and motor.

6.2 Positional requirements

WARNING



Leave the inlet screen in place if the pump installation is accessible to human touch.

Depending on the motor type, the pump can be installed either vertically or horizontally. A complete list of motor types suitable for horizontal installation is shown in section [6.2.1 Motors suitable for horizontal installation](#).

If the pump is installed horizontally, make sure that the outlet port never falls below the horizontal plane. See fig. 2.

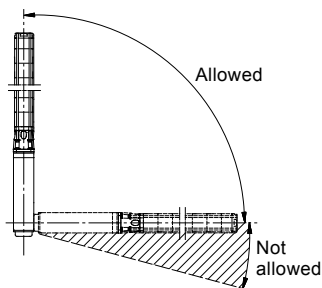

Fig. 2 Positional requirements

If the pump is installed horizontally, e.g. in a tank, we recommend that you fit it in a flow sleeve.

6.2.1 Motors suitable for horizontal installation

Motor	Output power 60 Hz	Output power 50 Hz
	[Hp (kW)]	[Hp (kW)]
MS	0.5 - 40 (0.37 - 30)	All
MMS6	50-60 (37 - 44.7)	5-50 (3.7 - 37)
MMS 8000	30-150 (22-112)	30-150 (22-112)
MMS 10000	100-250 (75-190)	100-250 (75-190)

CAUTION



During operation, the suction interconnector of the pump must always be completely submerged in the liquid. Make sure that the NPSH values are fulfilled.

WARNING



If the pump is used for pumping hot liquids of 104-140 °F (40-60 °C), make sure that persons cannot come into contact with the pump and the installation, e.g. by installing a guard.

TM00 1355 5092

6.2.2 Pumped liquids

CAUTION

This pump has been tested for use with water only. Water temperature should not exceed rated motor temperature. SP pumps can withstand water temperatures up to 140°F (60°C). Water temperature that exceeds motor rated temperature directly shortens the motor life. The suitability of this pump for use with liquids other than water is the responsibility of the end user.

Caution

Submersible pumps are designed for pumping the following liquids:

- clear and cold water that is free of air and gasses
- clean, thin, non-explosive liquids without solid particles or fibers.

Decreased pump performance and life expectancy can occur if the water is not cold and clear or contains air and gasses.

See the flow velocity table in section [10.1 Motor cooling requirements](#).

Flow rate, Q:	0.44 - 1475 gpm (0.1 - 335 m ³ /h)
Head, H:	Maximum 2657 ft (810 m)

When the pump and motor are used for pumping water above the rated temperatures of the motor, pay special attention to minimum water flow past the motor for cooling. Water temperature that exceeds motor rated temperature directly shortens the motor life.

The Grundfos stainless steel submersible pump is highly resistant to the normal corrosive environment found in some water wells. If water well tests show that the water has an excessive or unusual corrosive quality, or exceeds the motor temperature rating, contact your Grundfos representative for information concerning specially designed pumps for these applications.

6.3 Preparation

WARNING



Before starting work on the pump, make sure that the power supply has been switched off and that it cannot be accidentally switched on.

6.3.1 Checking of liquid in motor

The MS submersible motors are factory-filled with SML-3 liquid, which is frost-proof down to -4 °F (-20 °C).

Note

Check the level of the liquid in the motor, and refill the motor, if required. Use clean water.

CAUTION

Caution

If frost protection is required, use special Grundfos liquid to refill the motor. Otherwise clean water may be used for refilling. However, never use distilled water.

Carry out refilling of liquid as described below.

6.3.2 Grundfos submersible motors MS 4000 and MS 402

The filling hole for motor liquid is placed in the following positions:

MS 4000: In the top of the motor.

MS 402: In the bottom of the motor.

1. Position the submersible pump as shown in fig. 3.
2. Make sure that the filling screw is at the highest point of the motor.
3. Remove the screw from the filling hole.
4. Inject liquid into the motor with the filling syringe as shown in fig. 3 until the liquid runs back out of the filling hole.
5. Replace the screw in the filling hole and tighten securely before changing the position of the pump.

Torques:

MS 4000: 2.2 ft-lbs (3.0 Nm).

MS 402: 1.5 ft-lbs (2.0 Nm).

The submersible pump is now ready for installation.

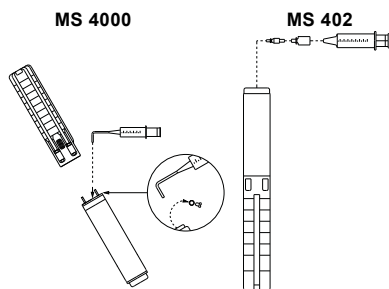

Fig. 3 Pump position during filling, MS 4000 and MS 402

6.3.3 Grundfos submersible motors, MS 6000C

- If the motor is delivered from stock, the liquid level must be checked before the motor is fitted to the pump. See fig. 4.
- On pumps delivered directly from Grundfos, the liquid level has already been checked.
- In the case of service, the liquid level must be checked. See fig. 4.

Filling procedure:

The filling hole for motor liquid is placed in the top of the motor.

1. Position the submersible pump as shown in fig. 4. Make sure that the filling screw is at the highest point of the motor.
2. Remove the screw from the filling hole.
3. Inject liquid into the motor with the filling syringe (see fig. 4) until the liquid runs back out of the filling hole.
4. Replace the screw in the filling hole and tighten securely before changing the position of the motor.

Torque: 2.2 ft-lbs (3.0 Nm).

The submersible pump is now ready for installation.

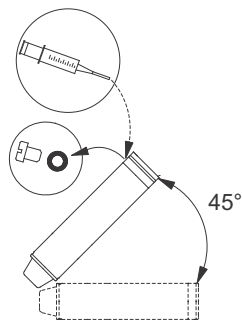

Fig. 4 Motor position during filling, MS 6000C

TM05 0949 1911

6.3.4 Grundfos submersible motors, MMS6, MMS 8000, and MMS 10000

Filling procedure:

1. Place the motor at a 45 ° angle with the top of the motor upwards. See fig. 5.
2. Unscrew the plug A and place a funnel in the hole.
3. Pour tap water into the motor until the motor liquid inside the motor starts running out at A.

CAUTION

Caution Do not use motor liquid as it contains oil.

4. Remove the funnel and refit the plug A.

CAUTION

Caution Before fitting the motor to a pump after a long period of storage, lubricate the shaft seal by adding a few drops of water and turning the shaft.

The submersible pump is now ready for installation.

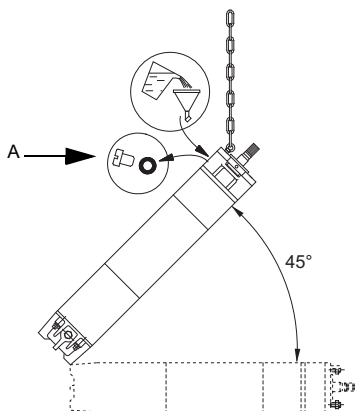

Fig. 5 Motor position during filling, MMS

TM03 0265 3605

6.3.5 Installation depth

Make sure that the installation depth of the pump is always at least 3 ft (1 m) below the maximum draw-down level of the well. For flow rates exceeding 100 gpm (22.7 m³/h), refer to performance curves for recommended minimum submergence.

Never install the pump so that the bottom of the motor is lower than the top of the well screen or within five feet of the well bottom.

If the pump is to be installed in a lake, pond, tank or large diameter well, make sure that the water velocity passing over the motor is sufficient to ensure proper motor cooling. The minimum recommended water flow rates ensuring proper cooling are listed in section [10.1 Motor cooling requirements](#).

6.3.6 Power supply

Check the motor voltage, phase number and frequency indicated on the motor nameplate against the actual power supply.

6.3.7 Power cable type

The power cable used between the pump and control box or control panel must be approved for submersible pump applications. Conductors may be solid or stranded. The cable may consist of individually insulated conductors twisted together, insulated conductors molded side by side in one flat cable or insulated conductors with a round overall jacket.

The conductor insulation must be type RW, RUW, TW, TWU or equivalent and must be suitable for use with submersible pumps. An equivalent Canadian Standards Association (CSA) certified cable may also be used. See section [10.4 Submersible drop cable selection charts \(60 Hz\)](#) for recommended cable lengths.

6.4 Removing and fitting the cable guard

If the cable guard is attached with screws, remove the screws to loosen the cable guard. To fit the cable guard on the pump, tighten the screws to fit the cable guard securely to the pump.

CAUTION

Caution

When the cable guard has been fitted, make sure that the pump chambers are aligned.

6.5 Splicing the motor cable

Note

A good cable splice is critical to proper operation of the submersible pump and must be done with extreme care.

If the splice is carefully made, it will work as well as any other portion of the cable, and will be completely watertight. Grundfos recommends that you use a heat shrink splice kit. Make the splice in accordance with the kit manufacturer's instructions. Typically a heat shrink splice can be made as follows:

1. Examine the motor cable and the submersible drop cable carefully for damage.
2. Cut the motor leads off in a staggered manner. Cut the ends of the drop cable so that the ends match up with the motor leads. See fig. 6. On single-phase motors, be sure to match the colors.
3. Strip back and trim off 1/2 inch of insulation from each lead, making sure to scrape the wire bare to obtain a good connection. Be careful not to damage the copper conductor when stripping off the insulation.
4. Slide the heat shrink tubing on to each lead. Insert a properly sized "Sta-Kon" type connector on each lead, making sure that lead colors are matched. Using "Sta-Kon" crimping pliers, indent the lugs. See fig. 7. Be sure to squeeze hard on the pliers, particularly in the case of a large cable.
5. Center the heat shrink tubing over the connector. Using a propane torch, lighter, or electric heat gun, uniformly heat the tubing starting first in the center working towards the ends. See fig. 8.
6. Continue to apply the heat to the tubing taking care not to let the flame directly contact the tubing. When the tubing shrinks and the sealant flows from the ends of the tubing, the splice is complete. See fig. 9.

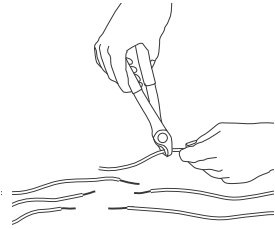

Fig. 6 Cutting and stripping the motor leads

TM05 0032 0611

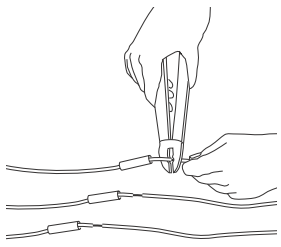

Fig. 7 Crimping the connectors

TM05 0033 0611

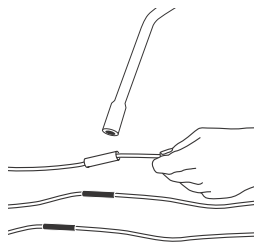

Fig. 8 Applying heat to the connector

TM05 0034 0611

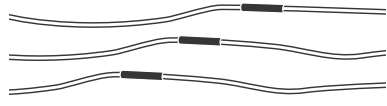

Fig. 9 Completed splices

TM05 0035 0611

6.6 Riser pipe

Note

Make sure that the riser pipe or hose are properly sized and selected on the basis of estimated flow rates and friction-loss factors.

6.6.1 If an adapter is required

We recommend that you first install the riser pipe to the pipe adapter. Then install the riser pipe with the adapter to the pump outlet port.

Use a back-up wrench when attaching the riser pipe to the pump. Make sure that the pump is gripped only by the flats on the top of the outlet chamber. The body of the pump, cable guard or motor must not be gripped under any circumstance.

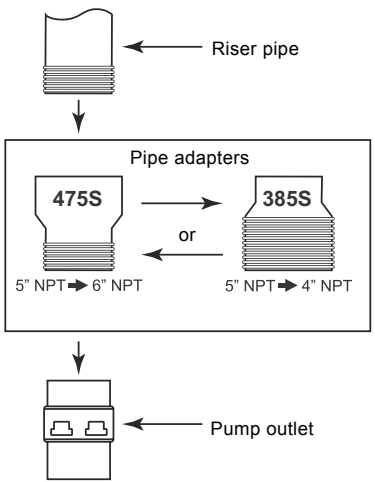

Fig. 10 Pipe adapters

TM05 0036 2013

6.6.2 If a steel riser pipe is used

We recommend that you always use steel riser pipes with the large submersible pumps. Use an approved pipe thread compound on all joints. Make sure the joints are adequately tightened in order to prevent the joints from coming loose when the motor starts and stops.

When tightened, make sure that the first section of the riser pipe does not come in contact with the check valve retainer.

After the first section of the riser pipe has been attached to the pump, clamp the lifting wire to the pump, if there is a provision on the pump for a lifting wire. If not, clamp the lifting wire to the first section of the riser pipe.

When raising the pump and riser pipe section to upright position, be careful not to place bending stress on the pump by picking it up by the pump end only.

Make sure that the power cables are not cut or damaged in any way when the pump is being lowered in the well.

Fasten the submersible drop cable to the riser pipe at frequent intervals to prevent sagging, looping or possible cable damage. Nylon cable clips or waterproof tape may be used. Protect the cable splice by securing it with clips or tape just above and below the splice.

6.6.3 If a plastic or flexible riser pipe is used

We recommend that you use plastic type riser pipes only with the smaller domestic submersible pumps.

CAUTION

Caution

When a plastic riser pipe is used, we recommend that you attach a safety cable to the pump to lower and raise it.

Important: Plastic and flexible pipes tend to stretch under load. Take this stretching into account when securing the cable to the riser pipe. Leave 3 to 4 inches of slack between clips or taped points to allow for this stretching. This tendency for plastic and flexible pipe to stretch also affects the calculation of the pump installation depth. As a general rule, you can estimate that plastic pipe stretches to approximately 2 % of its length. For example, if you installed 200 feet (61 m) of plastic riser pipe, the pump may actually be down 204 feet (62 m). If the installation depth is critical, check with the manufacturer of the pipe to determine how to compensate for pipe stretch.

Note

Contact the pipe manufacturer or representative to ensure that the pipe type and physical characteristics are suitable for this use.

Use the correct joint compound recommended by the pipe manufacturer. In addition to making sure that joints are securely fastened, we recommend that you use a torque arrester when using a plastic pipe.

Do not connect the first plastic or flexible riser pipe section directly to the pump. Always attach a metallic nipple or adapter into the valve casing at the top of the pump. When tightened, make sure that the threaded end of the nipple or adapter does not come in contact with the check valve retainer.

Fasten the submersible drop cable to the riser pipe at frequent intervals to prevent sagging, looping and possible cable damage. Grundfos nylon cable clips or waterproof tape may be used. Protect the cable splice by securing it with Grundfos cable clips or tape just above each joint.

Check valves

Always install a check valve at the top of the well. In addition, for installations deeper than 200 feet (61 m), install check valves at no more than 200 ft (61 m) intervals.

Protect the well from contamination

To protect against surface water entering the well and contaminating the water source, make sure that the well is finished off above grade and that a locally approved well seal or pitless adapter unit is utilized.

6.7 Electrical and variable-frequency drive information

WARNING



USA: All electrical work must be performed by a qualified electrician and installed in accordance with the National Electrical Code, local codes and regulations.

WARNING



Canada: All electrical work must be performed by a qualified electrician and installed in accordance with the Canadian Electrical Code, local codes and regulations.

WARNING



Provide acceptable grounding in order to reduce the risk of electric shock during operation of this pump. If the means of connection to the box connected to the power supply is other than a grounded metal conduit, ground the pump by connecting a copper conductor, at least the size of the circuit supplying the pump, to the grounding screw provided within the terminal box.

Make sure that the voltage, phase number and frequency of the power supply match those of the motor. Motor voltage, phase number, frequency and full-load current information can be found on the nameplate attached to the motor.

Motor electrical data can be found in section [10.6.1 Grundfos submersible motors, 60 Hz](#).

WARNING



If voltage variations are larger than $\pm 10\%$, do not operate the pump.

Direct-on-line starting is used due to the extremely short run-up time of the motor (maximum 0.1 second), and the low moment of inertia of the pump and motor. Direct-on-line starting current (locked rotor current) is between 4 and 6.5 times the full-load current.

If direct-on-line starting is not acceptable and reduced starting current is required, use an autotransformer or resistant starters for 5 to 30 hp motors, depending on the cable length. For motors over 30 hp, use autotransformer starters.

6.7.1 Engine-driven generators

If the submersible pump is going to be operated by an engine driven generator, we suggest that you contact the manufacturer of the generator to ensure the proper generator is selected and used. See section [10.2 Guide for engine-driven generators in submersible pump applications](#) for generator sizing guide.

If power is going to be supplied through transformers, section [10.3 Transformer capacity required for three-phase submersible motors](#) outlines the minimum KVA rating and capacity required for satisfactory pump operation.

6.7.2 Control box or panel wiring

Single-phase motors

Connect single-phase motors as indicated in the motor control box.

A typical single-phase wiring diagram using a Grundfos control box is shown in fig. 11.

CAUTION

Caution Motor burnout protection via CUE, CU331SP, or MP 204.

Use approved dry-run protection such as with MP 204.

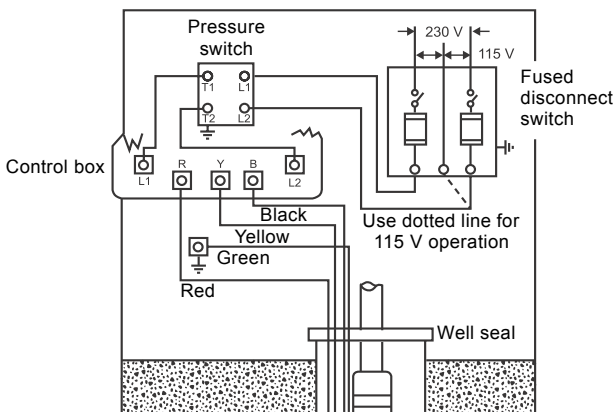

Fig. 11 Single-phase wiring diagram for Grundfos control boxes

Three-phase motors

Use three-phase motors with the proper size and type of motor starter to ensure the motor is protected against damage from low voltage, phase failure, current imbalance and overload current.

Use a properly sized starter with ambient-compensated, class 10, extra quick-trip overload relays or an MP204 to give the best possible motor winding protection.

Each of the three motor legs must be protected with overloads. The thermal overloads must trip in less than 10 seconds at locked rotor (starting) current. A three-phase motor wiring diagram is shown in fig. 12.

CAUTION

Caution

Ensure that the pump is totally submerged before you check the direction of rotation. Severe damage may be caused to the pump and motor if they are run dry.

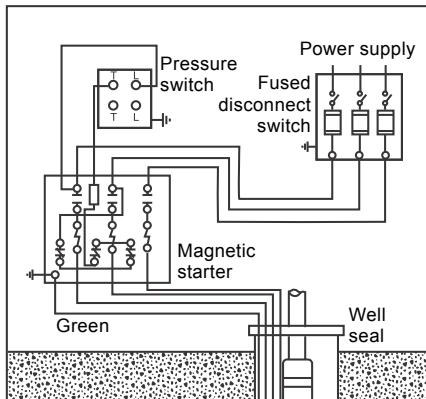

Fig. 12 Three-phase wiring diagram for Grundfos motors and other motor manufacturers

TM05 0038 2413

6.7.3 Variable-frequency drive operation

Grundfos motors

Three-phase Grundfos motors can be connected to a variable frequency drive (VFD).

If a Grundfos MS motor with temperature transmitter is connected to a variable frequency drive, a fuse incorporated in the transmitter will melt, and the transmitter will be inactive. The transmitter cannot be reactivated. This means that from that point on, the motor will operate like a motor without a temperature transmitter.

Note

If a new temperature transmitter is required, a Pt100/1000 sensor for fitting to the submersible motor can be ordered from Grundfos.

During variable-frequency drive operation, we recommend that you do not run the motor at a frequency higher than the nominal frequency (50 or 60 Hz) and not lower than 30 Hz. In connection with pump operation, it is important never to reduce the frequency (and consequently the speed) to such a low level that the necessary flow of cooling liquid past the motor is no longer ensured.

To avoid damage to the pump, make sure that the motor stops when the pump flow falls below 0.1 x rated flow.

Depending on the type of variable frequency drive, it may expose the motor to detrimental voltage peaks.

The variable frequency drive must have some kind of output sine-wave filter to limit voltage peaks (U_{peak}) and to reduce dU/dt (or dV/dt) which causes stress on the insulation of the submersible motor. For sine-wave filter location placement within the system, see fig. 13.

CAUTION

We recommend that you protect your motor from voltage peaks (U_{peak}) and excess dU/dt (or dV/dt) by using a sine-wave filter if one or more of the following conditions are present:

- The motor nameplate voltage is above 379 V.
- The variable frequency drive (VFD) uses pulse width modulation (PWM) and/or IGBT-BJT switches.
- The VFD voltage rise time is less than 2 msec (NEMA MG 1-2011).
- The power cable length from the VFD to the submersible motor terminals is 0 to 1500 ft (0 to 457 m).
- The power quality is not stable.
- Keep the motor peak voltage (U_{peak}) and dU/dt within the limits listed in the table below.

Caution

For recommended best practice, use a resistor-inductor-capacitor (RLC) type sine-wave filter. An equivalent type LC sine-wave filter is acceptable. Consult the VFD manufacturer for specific sine-wave filter recommendation.

Maximum peak voltage and dU/dt for Grundfos submersible motors

Motor series	Maximum U_{peak} voltage	Maximum dU/dt
MS 402	650 V phase-phase	2000 V/micro s.
MS 4000	850 V phase-phase	2000 V/micro s.
MS6 / MS 6000C	850 V phase-phase	2000 V/micro s.
MMS6 / MMS 6000	850 V phase-ground	500 V/micro s.
MMS 8000	850 V phase-ground	500 V/micro s.
MMS 10000	850 V phase-ground	500 V/micro s.

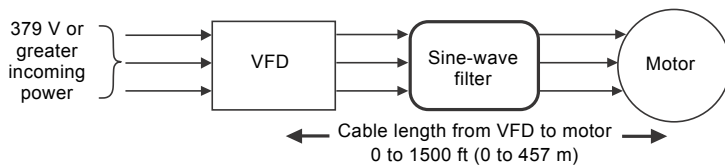

Fig. 13 Location of the sine-wave filter in the system

For further details, contact your VFD supplier or Grundfos.

TIM06 6056 0516

6.7.4 High-voltage surge arresters

Use a high-voltage surge arrester to protect the motor against lightning and switching surges.

Lightning voltage surges in power lines are caused when lightning strikes somewhere in the area.

Switching surges are caused by the opening and closing of switches on the main high-voltage distribution power lines.

Install the correct voltage-rated surge arrester on the supply side of the control box. See fig. 14 and fig. 15. The arrester must be grounded in accordance with the National Electrical Code and local codes and regulations.

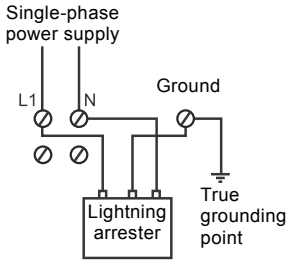

Fig. 14 Single-phase installation

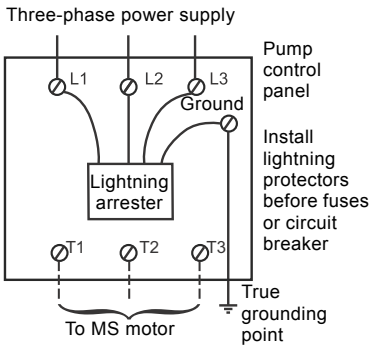

Fig. 15 Three-phase installation

The warranty on all three-phase submersible motors becomes void in these cases:

- The motor is operated with single-phase power through a phase converter.
- Three-leg ambient compensated, extra quick-trip overload protectors are not used.
- Three-phase current imbalance is not checked and recorded. See section 7. *Startup*.
- High-voltage surge arresters are not installed.

Note

6.7.5 Control box or panel grounding

WARNING



The control box or control panel must be permanently grounded in accordance with the National Electrical Code and local codes or regulations.

The ground wire must be a bare copper conductor at least the same size as the submersible drop cable wire size.

Run the ground wire as short a distance as possible and fasten it securely to a true grounding point.

TM05 0039 0611

TM05 0040 0611

True grounding points are considered to be one of the following:

- a grounding rod driven into the water strata
- a steel well casing submerged into the water lower than the pump installation depth
- steel outlet pipes without insulating couplings.

If plastic outlet pipe and well casing are used or if a grounding wire is required by local codes, connect a properly sized, bare copper wire to a stud on the motor and run to the control panel.

WARNING



Do not ground to a gas supply line. Connect the grounding wire to the ground point first and then to the terminal in the control box or control panel.

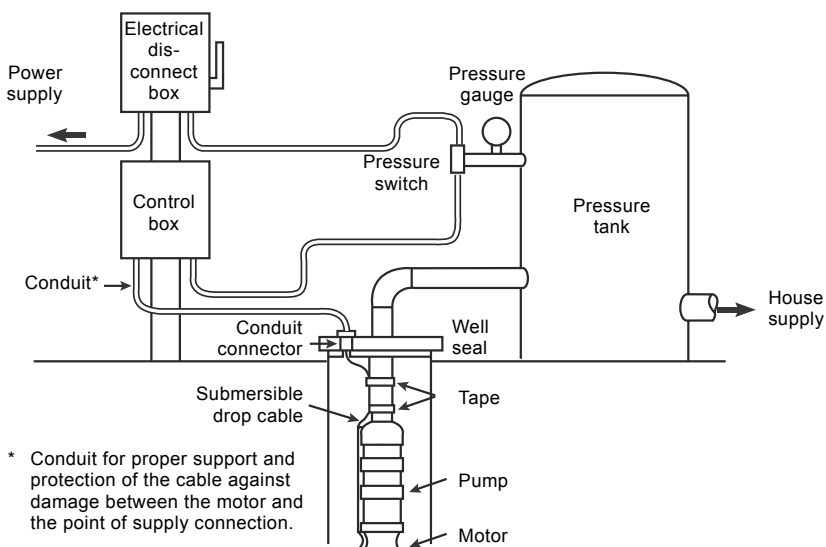

Fig. 16 Wiring and installation diagram

TM05 0041 0611

6.7.6 Wiring checks and installation

Before making the final surface wiring connection of the submersible drop cable to the control box or control panel, it is a good practice to check the insulation resistance to ensure that the cable and splice are good. Measurements for a new installation must be at least 200 megaohms. See the table in section

[6.7.7 Insulation resistance and ohm value chart](#).

If the insulation resistance of the cable and splice is measured at higher than 200 megaohms, run the submersible drop cable through the well seal by means of a conduit connector to prevent foreign matter from entering the well casing.

Always protect the submersible drop cable with conduit from the pump to the control box or control panel. See fig. 16.

Finish the wiring and verify that all electrical connections are made in accordance with the wiring diagram.

Check to ensure that the control box or control panel and high-voltage surge arrester have been grounded.

Route conductors properly such as in conduit where called for by Local Code to protect the conductors.

6.7.7 Insulation resistance and ohm value chart

Insulation resistance in a submersible pumping system is a measure of the ability of the motors and/or cables to withstand normal voltage and transient voltage without breakdown and failure. An "adequate" level of insulation resistance is not a constant value, but depends on the installation voltage and conditions, and whether the measured resistance is lowered by a specific weak point or by widely distributed conductance such as in cable insulation material itself. For this reason, values for acceptable resistance cannot be specific.

Insulation resistance measurements

Measure insulation resistance at the time of initial motor installation and periodically thereafter. In deep set submersible installations, take measurements throughout the installation process to detect potential cable insulation or connection damage before the unit is completely installed. The insulation resistance table in this section describes the condition of the insulation system for a submersible motor system of 600 V or less, based on megohmmeter readings.

Note Measure the insulation resistance in accordance with local codes and regulations.

The table below shows suggested values of insulation resistance and the test voltage in relation to the rated voltage of the motor.

Rated voltage	≤ 500 [V]	> 500 [V]
Condition of motor and cable	[MΩ]	[MΩ]
New motor without submersible drop cable	≥ 200	≥ 200
Used motor which can be re-installed in well	≥ 10	≥ 10
New motor in well	≥ 20	≥ 20
Motor in good condition in well	≥ 0.5	≥ 1
Damaged insulation	< 0.5	< 1

If the rated motor voltage is less than or equal to 500 V, the insulation resistance must be measured at a test voltage of 500 VDC.

If the rated motor voltage is greater than 500 V, the insulation resistance must be measured at a test voltage of 1000 VDC.

7. Startup

After the pump has been set into the well and the wiring connections have been made, go through the following procedures:

1. Attach a temporary horizontal length of pipe with installed gate valve to the riser pipe.
2. Adjust the gate valve one-third of the way open.
3. On three-phase units, check direction of rotation and current imbalance according to the instructions below. For single-phase units proceed directly to [7.1.3 Developing the well](#).
4. Do not operate the pump with the outlet valve closed. This can result in motor and pump damage due to overheating. Install a properly sized relief valve at the well head to prevent the pump from running against a closed valve.

7.1 Startup with three-phase motors

7.1.1 Check the direction of rotation

Three-phase motors can run in either direction depending on how they are connected to the power supply. When the three cable leads are first connected to the power supply, there is a 50 % chance that the motor will run in the proper direction. To make sure the motor is running in the proper direction, carefully follow these procedures:

1. Start the pump and check the water quantity and pressure developed.
2. Stop the pump and interchange any two leads.
3. Start the pump and again check the water quantity and pressure.
4. Compare the results observed. The wire connection which gave the highest pressure and largest water quantity is the correct connection.

7.1.2 Check for current imbalance

Current imbalance causes the motor to have reduced starting torque, overload tripping, excessive vibration and poor performance which can result in early motor failure. It is very important that current imbalance be checked in all three-phase systems.

Note

Make sure that the current imbalance between the phases do not exceed 5 % under normal operating conditions.

Determine if the supply power service is a two-transformer or three-transformer system. If two transformers are present, the system is an "open" delta or wye. If three transformers are present, the system is true three-phase.

Make sure the transformer ratings in kilovolt amps (KVA) is sufficient for the motor load. See section [10.3 Transformer capacity required for three-phase submersible motors](#).

The percentage of current imbalance can be calculated by means of the following formulas and procedures:

$$\text{Average current} = \frac{\text{Total of current values measured on each leg}}{3}$$

$$\% \text{ current imbalance} = \frac{\text{Greatest amp difference from the average}}{\text{Average current}} \times 100$$

To determine the percentage of current imbalance:

1. Measure and record current readings in amps for each leg (hookup 1). Disconnect power.
2. Shift or roll the motor leads from left to right so the submersible drop cable lead that was on terminal 1 is now on 2, lead on 2 is now on 3, and lead on 3 is now on 1 (hookup 2). Rolling the motor leads in this manner will not reverse the motor rotation. Start the pump, measure and record current reading on each leg. Disconnect power.
3. Again shift submersible drop cable leads from left to right so the lead on terminal 1 goes to 2, 2 to 3 and 3 to 1 (hookup 3). Start pump, measure and record current reading on each leg. Disconnect power.
4. Add the values for each hookup.
5. Divide the total by 3 to obtain the average.
6. Compare each single leg reading from the average to obtain the greatest amp difference from the average.
7. Divide this difference by the average to obtain the percentage of imbalance.

Use the wiring hookup which provides the lowest percentage of imbalance. See section [10.6.3 Correcting for three-phase current imbalance](#) for a specific example of correcting for three-phase current imbalance.

7.1.3 Developing the well

After proper rotation and current imbalance have been checked, start the pump and let it operate until the water runs clear of sand, silt and other impurities.

Slowly open the valve in small increments as the water clears until the desired flow rate is reached. Do not operate the pump beyond its maximum flow rating.

Note Do not stop the pump until the water runs clear.

If the water is clean and clear when the pump is first started, open the valve slowly until the desired flow rate is reached. As the valve is being opened, check the drawdown to ensure that the pump is always submerged.

Note Make sure that the dynamic water level is always more than 3 feet (0.9 m) above the suction interconnector of the pump.

Disconnect the temporary piping arrangements and complete the final piping connections.

CAUTION

Caution Do not operate the pump with the outlet valve closed. This can result in motor and pump damage due to overheating. Install a properly sized relief valve at the well head to prevent the pump from running against a closed valve.

Start the pump and test the system. Check and record the voltage and current draw on each motor lead.

8. Operation

Check the pump and system periodically for water quantity, pressure, drawdown, periods of cycling and operation of controls.

If the pump fails to operate, or there is a loss of performance, refer to section

[9. Troubleshooting](#).

8.1 Minimum flow rate

To ensure the necessary cooling of the motor, do not set the pump flow rate so low that the cooling requirements specified in section [6.2.2 Pumped liquids](#) cannot be met.

8.1.1 Frequency of starts and stops

Motor type		Number of starts
MS 402		<ul style="list-style-type: none"> • Minimum 1 per year is recommended. • Maximum 100 per hour. • Maximum 300 per day.
	MS 4000	<ul style="list-style-type: none"> • Minimum 1 per year is recommended. • Maximum 100 per hour. • Maximum 300 per day.
		<ul style="list-style-type: none"> • Minimum 1 per year is recommended. • Maximum 30 per hour. • Maximum 300 per day.
MMS6	PVC windings	<ul style="list-style-type: none"> • Minimum 1 per year is recommended. • Maximum 3 per hour. • Maximum 40 per day.
	PE/PA windings	<ul style="list-style-type: none"> • Minimum 1 per year is recommended. • Maximum 10 per hour. • Maximum 70 per day.
MMS 8000	PVC windings	<ul style="list-style-type: none"> • Minimum 1 per year is recommended. • Maximum 3 per hour. • Maximum 30 per day.
	PE/PA windings	<ul style="list-style-type: none"> • Minimum 1 per year is recommended. • Maximum 8 per hour. • Maximum 60 per day.
MMS 10000	PVC windings	<ul style="list-style-type: none"> • Minimum 1 per year is recommended. • Maximum 2 per hour. • Maximum 20 per day.
	PE/PA windings	<ul style="list-style-type: none"> • Minimum 1 per year is recommended. • Maximum 6 per hour. • Maximum 50 per day.

8.2 Soft starter

The starting voltage is minimum 55 % of the value stamped on the nameplate.

If a high locked-rotor torque is required or if the power supply is not optimal, the starting voltage must be higher.

Run-up time (until voltage stamped on nameplate is reached): Maximum 3 seconds.
Run-out time: Maximum 3 seconds.

If the above-mentioned run-up and run-out ramps are followed, unnecessary heating of the motor is avoided.

If the soft starter is fitted with bypass contacts, the soft starter will only be in operation during run-up and run-out.

Do not use the soft starter in connection with operation via a generator.

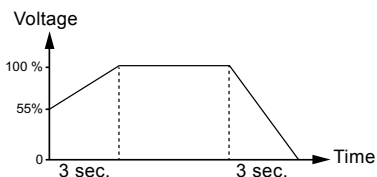

TM00 5172 2413

Fig. 17 Operation with a soft starter

8.3 Maintenance and service

All pumps are easy to service.

Service kits and service tools are available from Grundfos.

The pumps can be serviced at a Grundfos service center.



WARNING

If a pump has been used for a liquid which is injurious to health or toxic, the pump will be classified as contaminated.

If Grundfos is requested to service the pump, Grundfos must be contacted with details about the pumped liquid, etc. before the pump is returned for service. Otherwise Grundfos can refuse to accept the pump for service.

Possible costs of returning the pump are paid by the customer.

9. Troubleshooting

The majority of problems that develop with submersible pumps are electrical, and most of these problems can be corrected without pulling the pump from the well. The following chart covers most of the submersible service work. As with any troubleshooting procedure, start with the simplest solution first; always make all the above-ground checks before pulling the pump from the well.

Usually only two instruments are needed:

- a combination of voltmeter and ammeter
- an ohmmeter.

These are relatively inexpensive and can be obtained from most water systems suppliers.

WARNING



When working with electrical circuits, use caution to avoid electric shock.

We recommend that you use rubber gloves and boots and that you take care to have metal control boxes and motors grounded to power supply ground or steel drop pipe or casing extending into the well.



WARNING

Submersible motors are intended for operation in a well. When not operated in a well, failure to connect motor frame to power supply ground may result in serious electric shock.

9.1 Preliminary tests

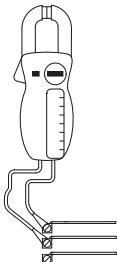
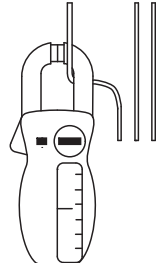
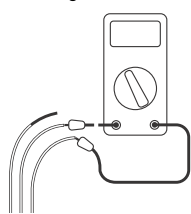
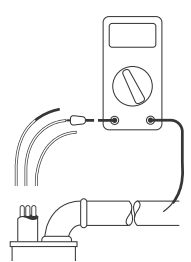
Test	How to measure	What it means
Supply voltage  TM00 1371 5092	<p>By means of a voltmeter set to the proper scale, measure the voltage at the control box or starter.</p> <ul style="list-style-type: none"> On single-phase units, measure between line and neutral. On three-phase units, measure between the legs (phases). 	<p>When the motor is under load, the voltage must be within $\pm 10\%$ of the nameplate voltage. Larger voltage variation may cause winding damage.</p> <p>Large variations in the voltage indicate a poor power supply and the pump must not be operated until these variations have been corrected. If the voltage constantly remains high or low, the motor must be changed to the correct supply voltage.</p>
Current  TM00 1372 5082	<ul style="list-style-type: none"> By means of an ammeter set to the proper scale, measure the current on each power lead at the control box or starter. See section 10.6 Electrical data for motor amp draw information. Current must be measured when the pump is operating at a constant outlet pressure with the motor fully loaded. 	<p>If the amp draw exceeds the listed service factor amps (SFA), or if the current imbalance is greater than 5% between each leg on three-phase units, check for the following:</p> <ul style="list-style-type: none"> Burnt contacts on motor-protective circuit breaker. Loose terminals in starter or control box or possible cable defect. Check winding and insulation resistances. Supply voltage too high or low. Motor windings are shortened. Pump is damaged, causing a motor overload.
Winding resistance  TM05 0028 0511	<ul style="list-style-type: none"> Turn off power and disconnect the submersible drop cable leads in the control box or starter. By means of an ohmmeter, set the scale selectors to Rx1 for values under 10 ohms and Rx10 for values over 10 ohms. Zero-adjust the ohmmeter and measure the resistance between leads. Record the values. Motor resistance values can be found in section 10.6 Electrical data. Cable resistance values are in section 6.7.7 Insulation resistance and ohm value chart. 	<p>If all the ohm values are normal, and the cable colors correct, the windings are not damaged.</p> <p>If any one ohm value is less than normal, the motors may be shorted. If any one ohm value is greater than normal, there is a poor cable connection or joint. The windings or cable may also be open.</p> <p>If some of the ohm values are greater than normal and some less, the submersible drop cable leads are mixed. To verify lead colors, see resistance values in section 10.6 Electrical data.</p>
Insulation resistance  TM05 0029 0511	<ul style="list-style-type: none"> Turn off power and disconnect the submersible drop cable leads in the control box or starter. By means of an ohmmeter or megohmmeter, set the scale selector to Rx 100K and zero adjust the meter. Measure the resistance between the lead and ground (discharge pipe or well casing, if steel). 	<p>For ohm values, refer to section 9.2 Checking pump performance. Motors of all hp, voltage, phase and cycle duties have the same value of insulation resistance.</p>

9.2 Checking pump performance

The troubleshooting chart on page 26 may require that you test the pump's performance against its curve. To do so, perform these steps:

1. Install pressure gauge.
2. Start pump.
3. Gradually close the outlet valve.
4. Read pressure at shut-off.
5. After taking reading, open valve to its previous position.
6. To calculate pump performance, first convert psi reading to feet.
For water: $\text{psi} \times 2.31 = \text{ ____ } \text{ feet.}$
7. Add this to the total vertical distance from the pressure gauge to the water level in the well while the pump is running.
8. Refer to the specific pump curve for the shut-off head (pressure) for that pump model. If the measured head is close to the curve, pump is probably OK.

9.3 Troubleshooting chart

Problem	Possible cause and/or how to check	Possible remedy
1. The pump does not run.	a) There is no power at the pump control panel. How to check: Check for voltage at the control panel.	If there is no voltage at the control panel, check the feeder panel for tripped circuits.
	b) The fuses are blown or the circuit breakers are tripped. How to check: Remove the fuses and check for continuity with the ohmmeter.	Replace blown fuses or reset the circuit breaker. If new fuses blow or the circuit breaker trips, the electrical installation and motor must be checked.
	c) The motor starter overloads are burnt or have tripped out (three-phase only). How to check: Check for voltage on the line or load side of the motor starter.	Replace burnt heaters or reset. Inspect the starter for other damage. If the heater trips again, check the supply voltage and the starter holding coil.
	d) The starter does not energize (three-phase only). How to check: Energize the control circuit and check for voltage at the holding coil.	If there is no voltage, check the control circuit. If there is voltage, check the holding coil for short circuits. Replace bad coil.
	e) The controls are defective. How to check: Check all safety and pressure switches for operation. Inspect contacts in control devices.	Replace worn or defective parts.
	f) The motor and/or cable are defective. How to check: Turn off the power. Disconnect the motor leads from the control box. Measure the lead-to-lead resistances with the ohmmeter (Rx1). Measure the lead-to-ground values with an ohmmeter (Rx100K). Record the measured values.	If an open motor winding or ground is found, pull the pump from the well and recheck values at the surface. Repair or replace the motor or cable.
	g) The capacitor is defective (single-phase only). How to check: Turn off the power, then the capacitor. Check with an ohmmeter (Rx100K). When the meter is connected, look for the needle to jump forward and slowly drift back.	If there is no ohmmeter needle movement, replace the capacitor.

Problem	Possible cause and/or how to check	Possible remedy
2. The pump runs but does not deliver water.	a) The groundwater level in the well is too low or the well is collapsed. How to check: Check the well drawdown. The water level must be at least three feet above the suction interconnector during operation.	If the water level is not at least three feet above the suction interconnector during operation, then lower the pump if possible, or throttle back the outlet valve and install a water level control.
	b) The integral pump check valve is blocked. How to check: Check the pump performance against the pump curve. See section 9.2 Checking pump performance .	If the pump is not operating close to the pump curve, pull the pump from the well and inspect the outlet section. Remove the blockage, repair the valve and valve seat, if necessary. Check for other damage. Rinse out the pump and re-install.
	c) The inlet strainer is clogged. How to check: Check the pump performance against the pump curve. See section 9.2 Checking pump performance .	If the pump is not operating close to the pump curve, pull the pump from the well and inspect. Clean the inlet strainer, inspect the integral check valve for blockage, rinse out the pump and re-install.
	d) The pump is damaged. How to check: Check the pump performance against the pump curve. See section 9.2 Checking pump performance .	If the pump is damaged, repair as necessary. Rinse out the pump and re-install.
3. The pump runs, but at reduced capacity.	a) The direction of rotation is wrong (three-phase only). How to check: Check for proper electrical connection in the control panel.	Correct the wiring and change the leads as required.
	b) The drawdown is larger than anticipated. Check the drawdown during pump operation.	Lower the pump, if possible. If not, throttle back the outlet valve and install a water level control.
	c) The outlet piping or valve are leaking. How to check: Examine the system for leaks.	Repair leaks.
	d) The pump inlet strainer or check valve are clogged. How to check: Check the pump performance against the pump curve. See section 9.2 Checking pump performance .	If the pump performance is not close to the pump curve, pull the pump from the well and inspect. Clean the strainer, inspect the integral check valve for blockage, rinse out the pump and re-install.
	e) The pump is worn. How to check: Check the pump performance against the pump curve. See section 9.2 Checking pump performance .	If the pump performance is not close to the pump curve, pull the pump from the well and inspect.

Problem	Possible cause and/or how to check	Possible remedy
4. The pump cycles too much.	a) The pressure switch is not properly adjusted or is defective. How to check: Check the pressure setting on switch and operation. Check the voltage across closed contacts.	Re-adjust the switch or replace it if it is defective.
	b) The level control is not properly set or is defective. How to check: Check the setting and operation.	Re-adjust the setting; refer to the manufacturer data. Replace the level control if it is defective.
	c) The pressure in the diaphragm tank is insufficient or the tank or piping is leaking. How to check: Pump air into the tank or diaphragm chamber. Check the diaphragm for leaks. Check the tank and piping for leaks with soap and water solution. Check the air to water volume.	Repair or replace any damaged components.
	d) The snifter valve or bleed orifice are plugged. How to check: Examine the valve and orifice for dirt or corrosion.	Clean and/or replace any defective snifter valve or bleed orifice.
	e) The tank is too small. How to check: Check the tank size. We recommend that the tank volume is approximately 10 gallons for each gpm or pump capacity.	If the tank is too small, replace it with a proper size tank.

Problem	Possible cause and/or how to check	Possible remedy
5. Fuses blow or circuit breakers trip.	a) The voltage is too high or low. How to check: Check the voltage at the pump control panel. If not within $\pm 10\%$, check the cable size and length of run to pump control panel.	If the cable size is correct, contact the power company. If not, correct and/or replace as necessary.
	b) The three-phase current imbalance is too high or low. How to check: Check the current draw on each lead. The imbalance must be within $\pm 5\%$.	If current imbalance is not within $\pm 5\%$, contact the power supply company.
	c) The control box wiring and components are incorrect or defective (single-phase only). How to check: Check that the control box parts match the parts list. Check to see that the wiring matches the wiring diagram. Check for loose or broken wires or terminals.	Correct as required.
	d) The capacitor is defective (single-phase only). How to check: Turn off the power, then the capacitor. Check by means of an ohmmeter (Rx100K). When the ohmmeter is connected, look for the needle to jump forward and slowly drift back.	If there is no ohmmeter needle movement, replace the capacitor.
	e) The starting relay is defective (certain types of single-phase only). How to check: Check the resistance of the relay coil by means of an ohmmeter (Rx1000K). Check the contacts for wear.	Replace any defective starting relay.

10. Technical data

10.1 Motor cooling requirements

10.1.1 Maximum water temperature - minimum velocity/flow past the motor

Maximum water temperature - minimum velocity/flow past the motor					
Motor type	Minimum well casing or sleeve diameter	Minimum velocity	Minimum flow	Maximum temperature of pumped liquid	
				Vertical installation	Horizontal installation
	[in. (mm)]	[ft/s (m/s)]	[gpm (m ³ /h)]	[°F (°C)]	[°F (°C)]
MS 402 / MS 4000	4 (102)	0.00 (0.00)	0.0 (0.0)	86 (30)	Flow sleeve recommended*
MS 402 / MS 4000	4 (102)	0.25 (0.08)	1.2 (0.27)	104 (40)	104 (40)
MS 6000C (T40)	6 (152)	0.50 (0.15)	9 (2)	104 (40)	104 (40)
MS 6000C (T60)	6 (152)	3.30 (1.00)	30 (6.8)	140 (60)	140 (60)
MMS 6 (T30)	6 (152)	0.15 (0.05)	13 (3)	86 (30)	86 (30)
MMS 6 (T50)	6 (152)	0.15 (0.05)	13 (3)	122 (50)	122 (50)
MMS 8000 (T30)	8 (203)	0.50 (0.15)	25 (5.7)	86 (30)	86 (30)
MMS 6 (T50)	8 (203)	0.50 (0.15)	25 (5.7)	122 (50)	122 (50)
MS 10000 (175, 200 hp)	10 (254)	0.50 (0.15)	55 (12.5)	86 (30)	86 (30)
MS 10000 (250 hp)	10 (254)	0.50 (0.15)	41 (9.3)	68 (20)	68 (20)

ft/s = feet per second

* A flow inducer or flow sleeve must be used if the water enters the well above the motor or if there is insufficient water flow past the motor.

Note: For MMS6, 50 hp and MMS 8000, 150 hp, the maximum liquid temperature is 9 °F (5 °C) lower than the values stated in the table. For MMS 10000, 250 hp, the temperature is 18 °F (10 °C) lower.

10.2 Guide for engine-driven generators in submersible pump applications

1- or 3-phase motor [Hp]	Generator [kW]	
	Externally regulated	Internally regulated
0.33	1.5	1.2
0.5	2.0	1.5
0.75	3.0	2.0
1	4.0	2.5
1.5	5.0	3.0
2	7.5	4.0
3	10.0	5.0
5.0	15.0	7.5
7.5	20.0	10.0
10.0	30.0	15.0
15.0	40.0	20.0
20.0	60.0	25.0
25.0	75.0	30.0
30.0	100.0	40.0
40.0	100.0	50.0
50.0	150.0	60.0
60.0	175.0	75.0
75.0	250.0	100.0
100.0	300.0	150.0
125.0	375.0	175.0
150.0	450.0	200.0
200.0	600.0	275.0

Note:

- The table is based on typical +176 °F (+80 °C) rise continuous duty generators with 35 % maximum voltage dip during startup of single-phase and three-phase motors.
- Contact the manufacturer of the generator to make sure the unit has adequate capacity to run the submersible motor.
- If the generator rating is in KVA instead of kilowatts, multiply the above ratings by 1.25 to obtain KVA.

10.3 Transformer capacity required for three-phase submersible motors

3-phase motor [Hp]	Minimum total KVA required*	Minimum KVA rating for each transformer	
		Two transformers Open Delta or Wye	Three transformers Delta or Wye
1.5	3	2	1
2	4	2	1.5
3	5	3	2
5	7.5	5	3
7.5	10	7.5	5
10	15	10	5
15	20	15	7.5
20	25	15	10
25	30	20	10
30	40	25	15
40	50	30	20
50	60	35	20
60	75	40	25
75	90	50	30
100	120	65	40
125	150	85	50
150	175	100	60
200	230	130	75

* Pump motor KVA requirements only, and does not include allowances for other loads.

10.4 Submersible drop cable selection charts (60 Hz)

The following tables list the recommended copper conductor sizes and various cable lengths for submersible motors.

These tables comply with the 1978 edition of the National Electric Table 310-16, Column 2 for +167 °F (+75 °C) wire. The ampacity (current carrying properties of a conductor) have been divided by 1.25 per the N.E.C., Article 430-22, for motor branch circuits based on motor amps at rated horsepower.

To ensure adequate starting torque, the maximum cable lengths are calculated to maintain 95 % of the service entrance voltage at the motor when the motor is running at maximum nameplate amps. Cable sizes larger than specified may always be used and will reduce power consumption.

CAUTION

Caution

The use of cables smaller than the recommended sizes will void the warranty. Smaller cable sizes will cause reduced starting torque and poor motor operation.

10.4.1 115 V and 230 V, 1-phase, 60 Hz

Maximum submersible power cable length (maximum cable length in feet, starter to motor)														
Motor rating [Hp]	AWG copper wire size [ft (m)]													
	14	12	10	8	6	4	3	2	1	0	00	000	0000	
115 V 1-ph 60 Hz	0.33	130 (40)	210 (64)	340 (104)	540 (165)	840 (256)	1300 (396)	1610 (491)	1960 (597)	2390 (728)	2910 (887)	3540 (1079)	4210 (1283)	5060 (1542)
	0.5	100 (30)	160 (49)	250 (76)	390 (119)	620 (189)	960 (293)	1190 (363)	1460 (445)	1780 (543)	2160 (658)	2630 (802)	3140 (957)	3770 (1149)
230 V 1-ph 60 Hz	0.33	550 (168)	880 (268)	1390 (424)	2190 (668)	3400 (1036)	5250 (1600)	6520 (1987)	7960 (2426)	9690 (2954)	11770 (3587)	14320 (4365)	17050 (5197)	20460 (6236)
	0.5	400 (122)	650 (198)	1020 (311)	1610 (491)	2510 (765)	3880 (1183)	4810 (1466)	5880 (1792)	7170 (2185)	8720 (2658)	10620 (3237)	12660 (3859)	15210 (4636)
	0.75	300 (91)	480 (146)	760 (232)	1200 (366)	1870 (570)	2890 (881)	3580 (1091)	4370 (1332)	5330 (1625)	6470 (1972)	7870 (2399)	9380 (2859)	11250 (3429)
	1	250 (76)	400 (122)	630 (192)	990 (302)	1540 (469)	2380 (725)	2960 (902)	3610 (1100)	4410 (1344)	5360 (1634)	6520 (1987)	7780 (2371)	9350 (2850)
	1.5	190 (58)	310 (94)	480 (146)	770 (235)	1200 (366)	1870 (570)	2320 (707)	2850 (869)	3500 (1067)	4280 (1305)	5240 (1597)	6300 (1920)	7620 (2323)
	2	150 (46)	250 (76)	390 (119)	620 (189)	970 (296)	1530 (466)	1910 (582)	2360 (719)	2930 (893)	3620 (1103)	4480 (1366)	5470 (1667)	6700 (2042)
	3	120 (37)	190 (58)	300 (91)	470 (143)	750 (229)	1190 (363)	1490 (454)	1850 (564)	2320 (707)	2890 (881)	3610 (1100)	4470 (1362)	5550 (1692)
	5	-	110* (34*)	180 (55)	280 (85)	450 (137)	710 (216)	890 (271)	1110 (338)	1390 (424)	1740 (530)	2170 (661)	2680 (817)	3330 (1015)
	7.5	-	-	120* (37*)	200 (61)	310 (94)	490 (149)	610 (186)	750 (229)	930 (283)	1140 (347)	1410 (430)	1720 (524)	2100 (640)
	10	-	-	-	160* (49*)	250 (76)	390 (119)	490 (149)	600 (183)	750 (229)	930 (283)	1160 (354)	1430 (436)	1760 (536)
15	-	-	-	-	170* (52*)	270 (82)	340 (104)	430 (131)	530 (162)	660 (201)	820 (250)	1020 (311)	1260 (384)	

Note:

* Indicates single conductor only (not jacketed).

No asterisk indicates both jacketed cable and single conductor cables.

- The table is based on copper wire. If aluminum wire is used, multiply lengths by 0.5. The maximum allowable length of aluminum is considerably shorter than copper wire of same size.
- Make sure that the portion of the total cable which is between the service entrance and a motor starter/controller does not exceed 25 % of the total maximum length to ensure reliable starter operation. Single-phase control boxes may be connected at any point of the total cable length.
- The table is based on maintaining motor terminal voltage at 95 % of the service entrance voltage, running at maximum nameplate amperes. In general, a voltage drop must be maintained at 3 V / 100 ft or less.
- 1 foot = 0.305 meter (1 meter = 3.28 feet).

10.4.2 200-208 V, 3-phase, 60 Hz

Maximum submersible power cable length (maximum cable length in feet, starter to motor)														
Motor rating [Hp]	AWG copper wire size [ft (m)]													
	14	12	10	8	6	4	3	2	1	0	00	000	0000	
200-208 V 3-ph 60 Hz	.5	710 (216)	1140 (347)	1800 (549)	2840 (866)	4420 (1347)	-	-	-	-	-	-	-	
	.75	510 (155)	810 (245)	1280 (390)	2030 (619)	3160 (963)	-	-	-	-	-	-	-	
	1	430 (131)	690 (210)	1080 (329)	1710 (521)	2670 (814)	4140 (1262)	5140 (1567)	-	-	-	-	-	
	1.5	310 (94)	500 (152)	790 (241)	1260 (384)	1960 (597)	3050 (930)	3780 (1152)	-	-	-	-	-	
	2	240 (73)	390 (119)	610 (186)	970 (296)	1520 (463)	2360 (719)	2940 (896)	3610 (1100)	4430 (1350)	5420 (1652)	-	-	
	3	180 (55)	290 (88)	470 (143)	740 (226)	1160 (354)	1810 (552)	2250 (686)	2760 (841)	3390 (1033)	4130 (1259)	-	-	
	5	110* (34*)	170 (52)	280 (85)	440 (134)	690 (210)	1080 (329)	1350 (411)	1660 (506)	2040 (622)	2490 (759)	3050 (930)	3670 (1119)	4440 (1353)
	7.5	-	-	200 (61)	310 (94)	490 (149)	770 (235)	960 (293)	1180 (360)	1450 (442)	1770 (539)	2170 (661)	2600 (792)	3150 (960)
	10	-	-	-	230* (70*)	370 (113)	570 (174)	720 (219)	880 (268)	1090 (332)	1330 (405)	1640 (500)	1970 (600)	2390 (728)
	15	-	-	-	160* (49*)	250* (76*)	390 (119)	490 (149)	600 (183)	740 (226)	910 (277)	1110 (338)	1340 (408)	1630 (497)
	20	-	-	-	-	190* (58*)	300* (91*)	380 (116)	460 (140)	570 (174)	700 (213)	860 (262)	1050 (320)	1270 (387)
	25	-	-	-	-	-	240* (73*)	300* (91*)	370* (113*)	460 (140)	570 (174)	700 (213)	840 (256)	1030 (314)
30	-	-	-	-	-	-	250* (76*)	310* (94*)	380* (116*)	470 (143)	580 (177)	700 (213)	850 (259)	

Note:

* Indicates single conductor only (not jacketed).

No asterisk indicates both jacketed cable and single conductor cables.

- The table is based on copper wire. If aluminum wire is used, multiply lengths by 0.5. The maximum allowable length of aluminum is considerably shorter than copper wire of same size.
- Make sure that the portion of the total cable which is between the service entrance and a motor starter/controller does not exceed 25 % of the total maximum length to ensure reliable starter operation. Single-phase control boxes may be connected at any point of the total cable length.
- The table is based on maintaining motor terminal voltage at 95 % of service entrance voltage, running at maximum nameplate amperes. In general, a voltage drop must be maintained at 3 V / 100 ft or less.
- 1 foot = 0.305 meter (1 meter = 3.28 feet).

10.4.3 230 V, 3-phase, 60 Hz

Maximum submersible power cable length (maximum cable length in feet, starter to motor)														
Motor rating [Hp]	AWG copper wire size [ft (m)]													
	14	12	10	8	6	4	3	2	1	0	00	000	0000	
230 V 3-ph 60 Hz	.5	930 (283)	1490 (454)	2350 (716)	3700 (1128)	5760 (1756)	8910 (2716)	-	-	-	-	-	-	
	.75	670 (204)	1080 (329)	1700 (518)	2580 (786)	4190 (1277)	6490 (1978)	8060 (2457)	9860 (3005)	-	-	-	-	
	1	560 (171)	910 (277)	1430 (436)	2260 (689)	3520 (1073)	5460 (1664)	6780 (2067)	8290 (2527)	-	-	-	-	
	1.5	420 (128)	670 (204)	1060 (323)	1670 (509)	2610 (796)	4050 (1234)	5030 (1533)	6160 (1878)	7530 (2295)	9170 (2795)	-	-	
	2	320 (98)	510 (155)	810 (247)	1280 (390)	2010 (613)	3130 (954)	3890 (1186)	4770 (1454)	5860 (1786)	7170 (2185)	8780 (2676)	-	-
	3	240 (73)	390 (119)	620 (189)	990 (302)	1540 (469)	2400 (732)	2980 (908)	3660 (1116)	4480 (1366)	5470 (1667)	6690 (2039)	8020 (2444)	9680 (2950)
	5	140* (43*)	230 (70)	370 (113)	590 (180)	920 (280)	1430 (436)	1790 (546)	2190 (668)	2690 (820)	3290 (1003)	4030 (1228)	4850 (1478)	5870 (1789)
	7.5	-	160* (49*)	260 (79)	420 (128)	650 (198)	1020 (311)	1270 (387)	1560 (475)	1920 (585)	2340 (713)	2870 (875)	3440 (1049)	4160 (1268)
	10	-	-	190* (58*)	310 (94)	490 (149)	760 (232)	950 (290)	1170 (357)	1440 (439)	1760 (536)	2160 (658)	2610 (796)	3160 (963)
	15	-	-	-	210* (64*)	330 (101)	520 (158)	650 (198)	800 (244)	980 (299)	1200 (366)	1470 (448)	1780 (543)	2150 (655)
	20	-	-	-	-	250* (76*)	400 (122)	500 (152)	610 (186)	760 (232)	930 (283)	1140 (347)	1380 (421)	1680 (512)
	25	-	-	-	-	-	320* (98*)	400 (122)	500 (152)	610 (186)	750 (229)	920 (280)	1120 (341)	1360 (415)
	30	-	-	-	-	-	260* (79*)	330* (101*)	410* (125*)	510 (155)	620 (189)	760 (232)	930 (283)	1130 (344)

Note:

* Indicates single conductor only (not jacketed).

No asterisk indicates both jacketed cable and single-conductor cables.

- The table is based on copper wire. If aluminum wire is used, multiply lengths by 0.5. The maximum permissible length of aluminum is considerably shorter than copper wire of same size.
- Make sure that the portion of the total cable which is between the service entrance and a motor starter/controller does not exceed 25 % of the total maximum length to ensure reliable starter operation. Single-phase control boxes may be connected at any point of the total cable length.
- The table is based on maintaining motor terminal voltage at 95 % of service entrance voltage, running at maximum nameplate amperes. In general, a voltage drop must be maintained at 3 V / 100 ft or less.
- 1 foot = 0.305 meter (1 meter = 3.28 feet).

10.4.4 460 V, 3-phase, 60 Hz

Maximum submersible power cable length (maximum cable length in feet, starter to motor)															
Motor rating [Hp]	AWG copper wire size [ft (m)]														
	14	12	10	8	6	4	3	2	1	0	00	000	0000		
460 V 3-ph 60 Hz	.5	3770 (1149)	6020 (1835)	9460 (2883)	-	-	-	-	-	-	-	-	-		
	.75	2730 (832)	4350 (1326)	6850 (2088)	-	-	-	-	-	-	-	-	-		
	1	2300 (701)	3670 (1119)	5770 (1759)	9070 (2765)	-	-	-	-	-	-	-	-		
	1.5	1700 (518)	2710 (826)	4270 (1301)	6730 (2051)	-	-	-	-	-	-	-	-		
	2	1300 (396)	2070 (631)	3270 (997)	5150 (1570)	8050 (2454)	-	-	-	-	-	-	-		
	3	1000 (305)	1600 (488)	2520 (768)	3970 (1210)	6200 (1890)	-	-	-	-	-	-	-		
	5	590 (180)	950 (290)	1500 (457)	2360 (719)	3700 (1128)	5750 (1753)	-	-	-	-	-	-		
	7.5	420 (128)	680 (207)	1070 (326)	1690 (515)	2640 (805)	4100 (1250)	5100 (1554)	6260 (1908)	7680 (2341)	-	-	-		
	10	310 (94)	500 (152)	790 (241)	1250 (381)	1960 (597)	3050 (930)	3800 (1158)	4680 (1426)	5750 (1753)	7050 (2149)	-	-		
	15	-	340* (104*)	540 (165)	850 (259)	1340 (408)	2090 (637)	2600 (792)	3200 (975)	3930 (1198)	4810 (1466)	5900 (1798)	7110 (2167)		
	20	-	-	410 (125)	650 (198)	1030 (314)	1610 (491)	2000 (610)	2470 (753)	3040 (927)	3730 (1137)	4580 (1396)	5530 (1686)		
	25	-	-	330* (101*)	530 (162)	830 (253)	1300 (396)	1620 (494)	1990 (607)	2450 (747)	3010 (917)	3700 (1128)	4470 (1362)	5430 (1655)	
	30	-	-	270* (82*)	430 (131)	680 (207)	1070 (326)	1330 (405)	1640 (500)	2030 (619)	2490 (759)	3060 (933)	3700 (1128)	4500 (1372)	
	40	-	-	-	320* (98*)	500* (152*)	790 (241)	980 (299)	1210 (369)	1490 (454)	1830 (558)	2250 (686)	2710 (826)	3290 (1003)	
	50	-	-	-	-	410* (125*)	640 (195)	800 (244)	980 (299)	1210 (369)	1480 (451)	1810 (552)	2190 (668)	2650 (808)	
	60	-	-	-	-	-	540* (165*)	670* (204*)	830 (253)	1020 (311)	1250 (381)	1540 (469)	1850 (564)	2240 (683)	
	75	-	-	-	-	-	-	440* (134*)	550* (168*)	680* (207*)	840 (256)	1030 (314)	1260 (384)	1520 (463)	1850 (564)
	100	-	-	-	-	-	-	-	500* (152*)	620 (189*)	760* (232*)	940 (287)	1130 (344)	1380 (421)	
	125	-	-	-	-	-	-	-	-	-	600* (183*)	740* (226*)	890* (271*)	1000 (305)	
	150	-	-	-	-	-	-	-	-	-	-	630* (192*)	760* (232*)	920* (280*)	
175	-	-	-	-	-	-	-	-	-	-	-	670* (204*)	810* (247*)		
200	-	-	-	-	-	-	-	-	-	-	-	590* (180*)	710* (216*)		

Note:

* Indicates single conductor only (not jacketed).

No asterisk indicates both jacketed cable and single-conductor cables.

- The table is based on copper wire. If aluminum wire is used, multiply lengths by 0.5.

The maximum permissible length of aluminum is considerably shorter than copper wire of same size.

- Make sure that the portion of the total cable which is between the service entrance and a motor starter/controller does not exceed 25 % of the total maximum length to ensure reliable starter operation. Single-phase control boxes may be connected at any point of the total cable length.
- The table is based on maintaining motor terminal voltage at 95 % of service entrance voltage, running at maximum nameplate amperes. In general, a voltage drop must be maintained at 3 V/100 ft or less.
- 1 foot = 0.305 meter (1 meter = 3.28 feet).

10.4.5 575 V, 3-phase, 60 Hz

		Maximum submersible power cable length (maximum cable length in feet, starter to motor)												
Motor rating [Hp]	AWG copper wire size [ft (m)]													
	14	12	10	8	6	4	3	2	1	0	00	000	0000	
575 V 3-ph 60 Hz	5	5900 (1798)	9410 (2868)	-	-	-	-	-	-	-	-	-	-	-
	.75	4270 (1301)	6810 (2076)	-	-	-	-	-	-	-	-	-	-	-
	1	3630 (1106)	5800 (1768)	9120 (2780)	-	-	-	-	-	-	-	-	-	-
	1.5	2620 (799)	4180 (1274)	6580 (2006)	-	-	-	-	-	-	-	-	-	-
	2	2030 (619)	3250 (991)	5110 (1558)	8060 (2457)	-	-	-	-	-	-	-	-	-
	3	1580 (482)	2530 (771)	3980 (1213)	6270 (1911)	-	-	-	-	-	-	-	-	-
	5	920 (280)	1480 (451)	2330 (710)	3680 (1122)	5750 (1753)	-	-	-	-	-	-	-	-
	7.5	660 (201)	1060 (323)	1680 (512)	2650 (808)	4150 (1265)	-	-	-	-	-	-	-	-
	10	490 (149)	780 (238)	1240 (378)	1950 (594)	3060 (933)	4770 (1454)	5940 (1811)	-	-	-	-	-	-
	15	330* (101*)	530 (162)	850 (259)	1340 (408)	2090 (637)	3260 (994)	4060 (1237)	-	-	-	-	-	-
	20	-	410* (125*)	650 (198)	1030 (314)	1610 (491)	2520 (768)	3140 (957)	3860 (1177)	4760 (1451)	5830 (1777)	-	-	-
	25	-	-	520 (158)	830 (253)	1300 (396)	2030 (619)	2530 (771)	3110 (948)	3840 (1170)	4710 (1436)	-	-	-
	30	-	-	430* (131*)	680 (207)	1070 (326)	1670 (509)	2080 (634)	2560 (780)	3160 (963)	3880 (1183)	4770 (1454)	5780 (1762)	7030 (2143)
	40	-	-	-	500* (152*)	790 (241)	1240 (378)	1540 (469)	1900 (579)	2330 (710)	2860 (872)	3510 (1070)	4230 (1289)	5140 (1567)
	50	-	-	-	410* (125*)	640* (195*)	1000 (305)	1250 (381)	1540 (469)	1890 (576)	2310 (704)	2840 (866)	3420 (1042)	4140 (1262)
	60	-	-	-	-	540* (165*)	850 (259)	1060 (323)	1300 (396)	1600 (488)	1960 (597)	2400 (732)	2890 (881)	3500 (1067)
	75	-	-	-	-	-	690* (210*)	860 (262)	1060 (323)	1310 (399)	1600 (488)	1970 (600)	2380 (725)	2890 (881)
	100	-	-	-	-	-	-	640* (195*)	790* (241*)	970 (296)	1190 (363)	1460 (445)	1770 (539)	2150 (655)
	125	-	-	-	-	-	-	-	630* (192*)	770* (235*)	950 (290)	1160 (354)	1400 (427)	1690 (515)
	150	-	-	-	-	-	-	-	-	660* (202*)	800* (244*)	990* (302*)	1190 (363)	1440 (439)
175	-	-	-	-	-	-	-	-	-	700* (214*)	870* (265*)	1050* (320*)	1270 (387)	
200	-	-	-	-	-	-	-	-	-	-	760* (232*)	920* (280*)	1110* (338*)	

Note:

* Indicates single conductor only (not jacketed).







No asterisk indicates both jacketed cable and single-conductor cables.

- The table is based on copper wire. If aluminum wire is used, multiply lengths by 0.5.

The maximum permissible length of aluminum is considerably shorter than copper wire of same size.

- Make sure that the portion of the total cable which is between the service entrance and a motor starter/controller does not exceed 25 % of the total maximum length to ensure reliable starter operation. Single-phase control boxes may be connected at any point of the total cable length.
- The table is based on maintaining motor terminal voltage at 95 % of service entrance voltage, running at maximum nameplate amperes. In general, a voltage drop must be maintained at 3 V/100 ft or less.
- 1 foot = 0.305 meter (1 meter = 3.28 feet).

10.5 Approvals

SP 4"			
SP 4" pump end (5S - 77S)	 WATER QUALITY Drinking Water System Component NSF/ANSI 61 MH26400 NSF/ANSI 372		
MS 6000C motor	 Submersible Motor NSF/ANSI 372 MH26400		
MS 4000 motor			IAPMO File 6591
MS 402 motor			0.25 % lead

The Grundfos SP pumps are certified when driven by a certified motor provided with suitable overheating protection.

10.6 Electrical data

10.6.1 Grundfos submersible motors, 60 Hz

Grundfos submersible motors, 60 Hz										
Hp	Ph	Volt [V]	SF	Circuit breaker or fuses		Amperage		Full load		Max. thrust [lbs]
				Std.	Delay	Start [A]	Max. [A]	Eff. [%]	Power factor	
4-inch, single-phase, 2-wire motors (control box not required)										
0.5	1	115	1.60	35	15	55.0	12.0	62	76	900
0.5	1	230	1.60	15	7	34.5	6.0	62	76	900
0.75	1	230	1.50	20	9	40.5	8.4	62	75	900
1	1	230	1.40	25	12	48.4	9.8	63	82	900
1.5	1	230	1.30	35	15	62.0	13.1	64	85	900
4-inch, single-phase, 3-wire motors										
0.5	1	115	1.60	35	15	42.5	12.0	61	76	900
0.5	1	230	1.60	15	7	21.5	6.0	62	76	900
0.75	1	230	1.50	20	9	31.4	8.4	62	75	900
1	1	230	1.40	25	12	37.0	9.8	63	82	900
1.5	1	230	1.30	35	15	45.9	11.6	69	89	900
2	1	230	1.25	35	20	57.0	13.2	72	86	1500
3	1	230	1.15	45	30	77.0	17.0	74	93	1500
5	1	230	1.15	70	45	110.0	27.5	77	92	1500
4-inch, three-phase, 3-wire motors										
1.5	3	230	1.30	15	8	40.3	7.3	75	72	900
1.5	3	460	1.30	10	4	20.1	3.7	75	72	900
1.5	3	575	1.30	10	4	16.1	2.9	75	72	900
2	3	230	1.25	20	10	48	8.7	76	75	900
2	3	460	1.25	10	5	24	4.4	76	75	900
2	3	575	1.25	10	4	19.2	3.5	76	75	900
3	3	230	1.15	30	15	56	12.2	77	75	1500
3	3	460	1.15	15	7	28	6.1	77	75	1500
3	3	575	1.15	15	6	22	4.8	77	75	1500
5	3	230	1.15	40	25	108	19.8	80	82	1500
5	3	460	1.15	20	12	54	9.9	80	82	1500
5	3	575	1.15	15	9	54	7.9	80	82	1500
7.5	3	230	1.15	60	30	130	25.0	81	82	1500
7.5	3	460	1.15	35	15	67	13.2	81	82	1500
7.5	3	575	1.15	30	15	67	10.6	81	82	1500
10	3	460	1.15	50	30	90	18	81	80	1500

CAUTION

Caution

Single-phase motors (thermally protected): Use with approved motor control that matches motor input in full load amperes.

CAUTION

Caution

Three-phase motors: Use with approved motor control that matches motor input in full load amperes with overload element(s) selected or adjusted in accordance with control instructions.

Grundfos submersible motors, 60 Hz

Hp	Ph	Volt [V]	SF	Circuit breaker or fuses		Amperage		Full load		Max. thrust [lbs]
				Std.	Delay	Start [A]	Max. [A]	Eff. [%]	Power factor	
6-inch, three-phase motors										
7.5	3	208-230	1.15	65	40	114-130	23.4 - 27.5	81	85-84	6070
7.5	3	460	1.15	30	17	68	13.2	81	85	6070
7.5	3	575	1.15	30	17	51	10.2	81	85	6070
10	3	208-230	1.15	90	50	126-142	30.0 - 37.5	82	86-84	6070
10	3	460	1.15	40	25	75	17.4	82	85	6070
10	3	575	1.15	40	25	56.5	13.4	82	85	6070
15	3	208-230	1.15	130	75	198-224	44.5 - 53.5	83	86-84	6070
15	3	460	1.15	60	35	112	25	83	84	6070
15	3	575	1.15	60	35	84	19.4	83	84	6070
20	3	208-230	1.15	175	100	310-350	57.5 - 71.5	84	86-84	6070
20	3	460	1.15	80	45	186	33.5	84	84	6070
20	3	575	1.15	80	45	144	26	84	84	6070
25	3	208-230	1.15	200	125	395-445	71-87	84	87-84	6070
25	3	460	1.15	100	60	236	41	84	84	6070
25	3	575	1.15	100	60	180	32	84	84	6070
30	3	208-230	1.15	250	150	445-500	81-104	84	87-84	6070
30	3	460	1.15	125	70	265	48	85	85	6070
30	3	575	1.15	125	70	194	37	85	85	6070
40	3	460	1.15	170	90	330	65	85	84	6070
40	3	575	1.15	170	90	250	49.5	85	84	6070
50	3	460	1.15	225	125	405	73.0	83	83	6182
8-inch, three-phase motors										
40	3	460	1.15	175	100	380	55.7	83	85	13000
50	3	460	1.15	225	125	550	67.8	84	85	13000
60	3	460	1.15	250	150	640	80.4	86	85	13000
75	3	460	1.15	300	175	580	97.4	86	86	13000
100	3	460	1.15	400	225	570	130.4	87	86	13000
125	3	460	1.15	500	300	600	160.0	87	87	13000
150	3	460	1.15	600	350	580	191.3	86	87	13000
10-inch, three-phase motors										
175	3	460	1.15	700	400	570	230.4	88	85	13000
200	3	460	1.15	800	500	620	265.2	87	82	13000
250	3	460	1.15	1100	600	610	352.2	87	79	13000

10.6.2 Other motor manufacturers

Refer to the other motor manufacturers' application maintenance manual.

10.6.3 Correcting for three-phase current imbalance

Example: Check for current imbalance for a 230 volt, three-phase, 60 Hz submersible motor, 18.6 full load amps.

Solution: Steps 1 to 3 measure and record amps on each submersible drop cable lead for hookups 1, 2 and 3.

Observe that hookup 3 must be used since it shows the least amount of current imbalance. Therefore, the motor will operate at maximum efficiency and reliability.

By comparing the current values recorded on each leg, you will note the highest value was always on the same leg, L₃. This indicates the imbalance is in the power source. If the high current values were on a different leg each time the leads were changed, the imbalance would be caused by the motor or a poor connection.

If the current imbalance is greater than 5 %, contact your power supply company for help.

For a detailed explanation of three-phase balance procedures, see section 7.1 Startup with three-phase motors.

	Step 1 (hookup 1)	Step 2 (hookup 2)	Step 3 (hookup 3)
(T ₁)	DL ₁ = 25.5 amps	DL ₃ = 25 amps	DL ₂ = 25.0 amps
(T ₂)	DL ₂ = 23.0 amps	DL ₁ = 24 amps	DL ₃ = 24.5 amps
(T ₃)	DL ₃ = 26.5 amps	DL ₂ = 26 amps	DL ₁ = 25.5 amps
Step 4	Total = 75 amps	Total = 75 amps	Total = 75 amps
Step 5	Average current = $\frac{\text{total current}}{3 \text{ readings}} = \frac{75}{3} = 25 \text{ amps}$		
Step 6	Greatest amp difference from the average:	(hookup 1) = 25 - 23 = 2 (hookup 2) = 26 - 25 = 1 (hookup 3) = 25.5 - 25 = 0.5	
Step 7	% imbalance	(hookup 1) = 2/25 x 100 = 8 (hookup 2) = 1/25 x 100 = 4 (hookup 3) = 0.5/25 x 100 = 2	

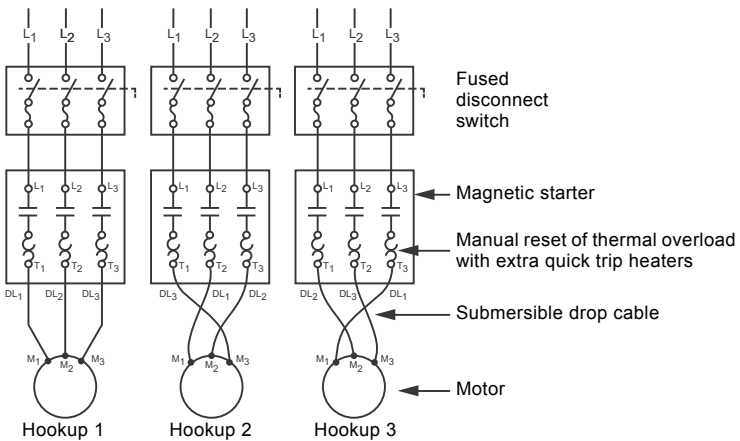

Fig. 18 Correcting for three-phase current imbalance

11. Disposal

This product or parts of it must be disposed of in an environmentally sound way:

1. Use the public or private waste collection service.
2. If this is not possible, contact the nearest Grundfos company or service workshop.

Removal and fitting of cable guard

Removing cable guard

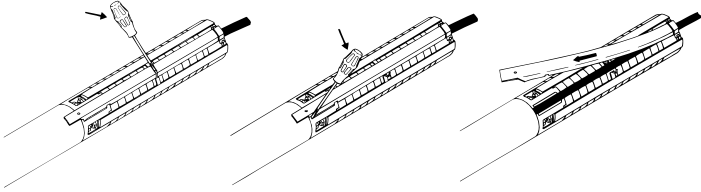

Fitting cable guard

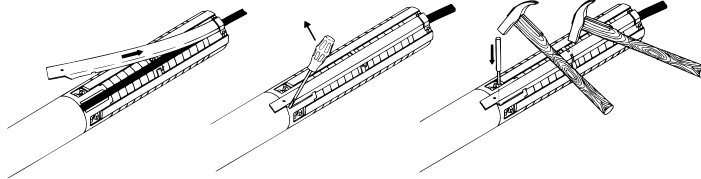
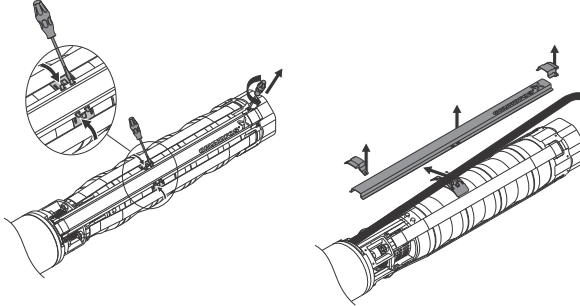

Fig. 1 Removal and fitting of cable guard for SP 5S, 7S, 10S, 16S, and 25S (smooth shaft)

Removing cable guard



Fitting cable guard

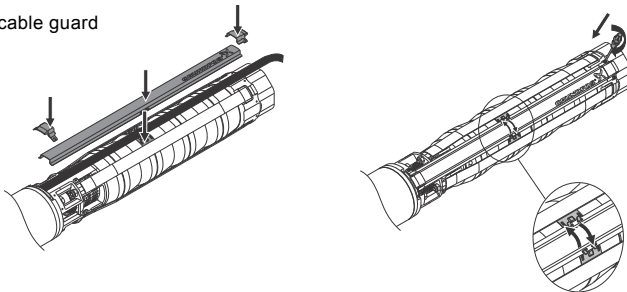
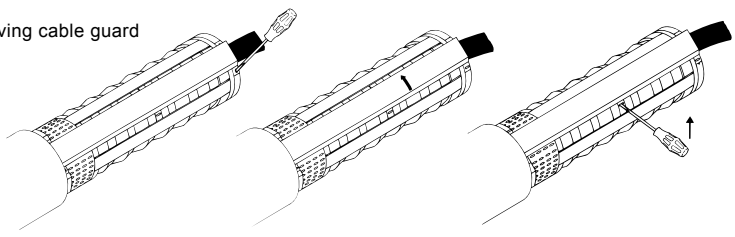

Fig. 2 Removal and fitting of cable guard for SP 35S, 45S, 62S, 77S, 150S, 230S, and 300S

TM00 1323 0603

TM06 0693 0814

Removing cable guard



Fitting cable guard

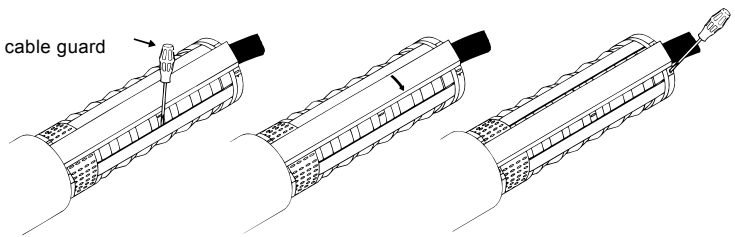
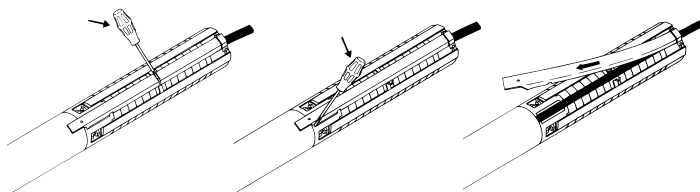

Fig. 3 Removal and fitting of cable guard for SP 385S, 475S, 625S, 800S, and 1100S

TM00 1326 0603

Dépose et fixation du protège-câble

Dépose du protège-câble



Fixation du protège-câble

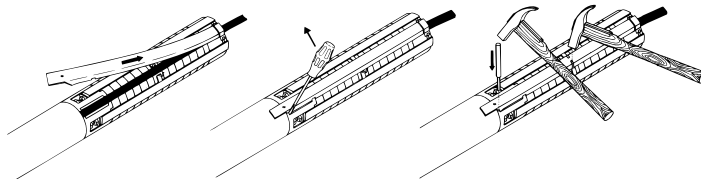
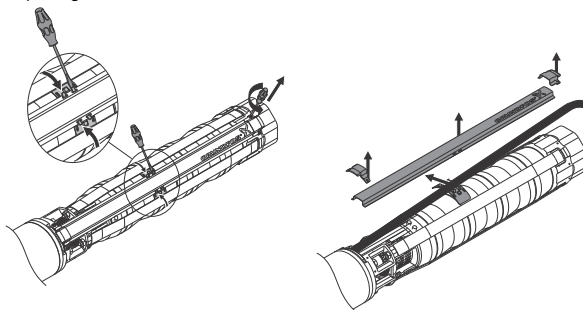

Fig. 1 Dépose et fixation du protège-câble pour SP 5S, 7S, 10S, 16S, et 25S (arbre lisse)

TM00 1323 0603

Dépose du protège-câble



Fixation du protège-câble

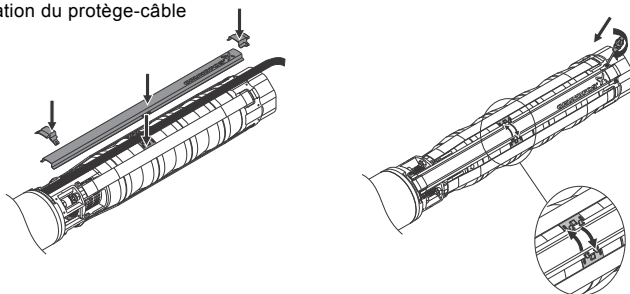
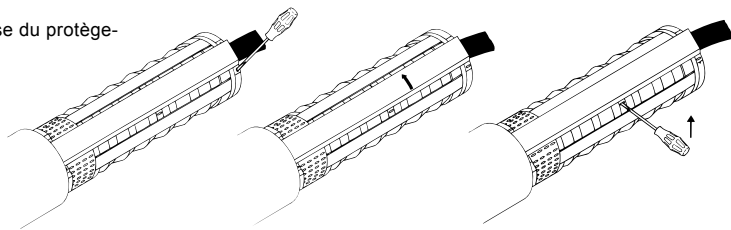

Fig. 2 Dépose et fixation du protège-câble pour SP 35S, 45S, 62S, 77S, 150S, 230S, et 300S

TM06 0693 0814

Dépose du protège-câble



Fixation du protège-câble

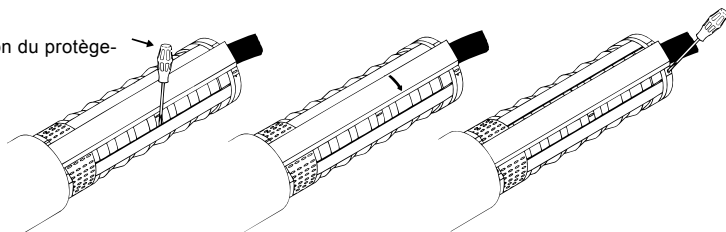
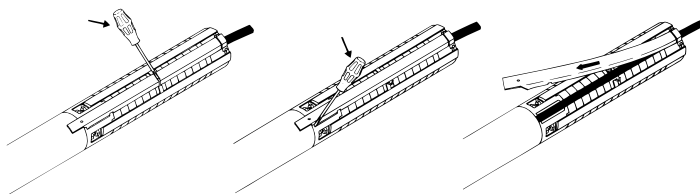

Fig. 3 Dépose et fixation du protège-câble pour SP 385S, 475S, 625S, 800S, et 1100S

TM00 1326 0603

Desmontaje e instalación de la cubierta del cable

Desmontaje de la cubierta del cable



Instalación de la cubierta del cable

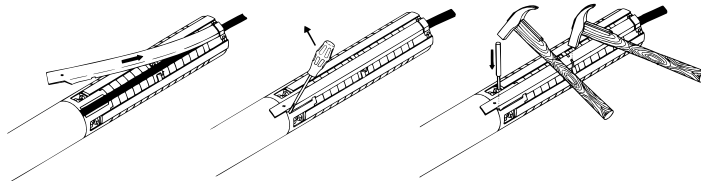
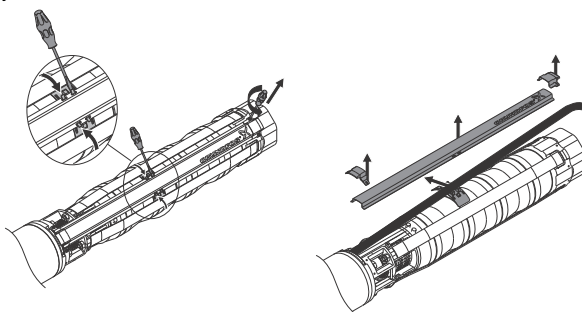

Fig. 1 Desmontaje e instalación de la cubierta del cable para bombas SP 5S, 7S, 10S, 16S y 25S (eje flexible)

TM00 1323 0603

Desmontaje de la cubierta del cable



Instalación de la cubierta del cable

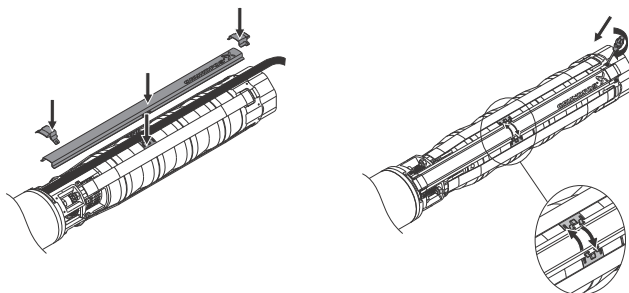
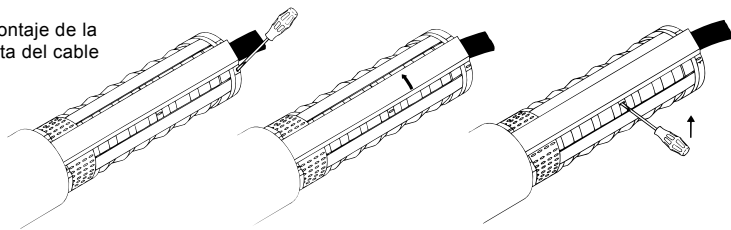

Fig. 2 Desmontaje e instalación de la cubierta del cable para bombas SP 35S, 45S, 62S, 77S, 150S, 230S, y 300S

TM06 0693 0814

Desmontaje de la
cubierta del cable



Instalación de la
cubierta del cable

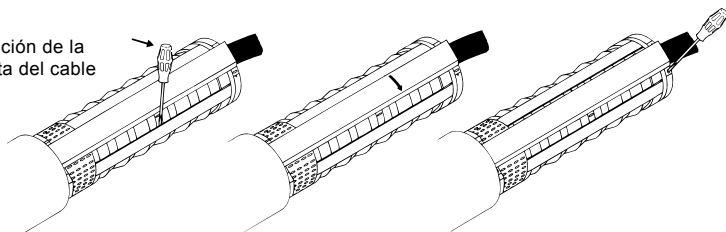

Fig. 3 Desmontaje e instalación de la cubierta del cable para bombas SP 385S, 475S, 625S, 800S y 1100S

TM00 1326 0603

Grundfos Kansas City

9300 Loiret Blvd.
Lenexa, Kansas 66219
Phone: +1-913-227-3400
Fax: +1-913-227-3500

www.grundfos.us

Grundfos Canada

2941 Brighton Road
Oakville, Ontario L6H 6C9 Canada
Phone: +1-905 829 9533
Fax: +1-905 829 9512

www.grundfos.ca

Grundfos México

Boulevard TLC No. 15
Parque Industrial Stiva Aeropuerto
C.P. 66600 Apodaca, N.L. Mexico
Phone: +011-52-81-8144 4000
Fax: +011-52-81-8144 4010

www.grundfos.mx

98559518 1118

ECM: 1248448

Trademarks displayed in this material, including but not limited to Grundfos, the Grundfos logo and "be think innovate" are registered trademarks owned by The Grundfos Group. All rights reserved. © 2018 Grundfos Holding A/S, all rights reserved.



2"-20"

MAIN LINE METERS

MODELS

ML03, ML07, ML11, ML15, ML19, ML21, MLT1

**OPERATION AND MAINTENANCE MANUAL
PARTS LIST**

FEATURING:

*STANDARD TOTALIZER ASSEMBLY

*CERAMIC BEARING CARTRIDGE PROPELLER

* ONE PIECE SEPARATOR/SPINDLE AND THREADED REVERSE THRUST BEARING CARTRIDGE



3255 WEST STETSON AVENUE
HEMET, CALIFORNIA 92545 U.S.A.

PHONE: 951-652-6811

FAX: 951-652-3078

VISIT OUR WEBSITE: www.mccrometer.com

WARRANTY

This Warranty shall apply to and be limited to the original purchaser consumer of any McCrometer product. Meters or instruments defective because of faulty material or workmanship will be repaired or replaced, at the option of Water Specialties, free of charge, FOB the factory in Hemet, California, within a period of one (1) year from the date of delivery.

Repairs or modifications by others than Water Specialties or their authorized representatives shall render this Warranty null and void in the event that factory examination reveals that such repair or modification was detrimental to the meter or instrument. Any deviations from the factory calibration require notification in writing to McCrometer of such recalibrations or this Warranty shall be voided.

In case of a claim under this Warranty, the claimant is instructed to contact McCrometer, 3255 W. Stetson Ave., Hemet, California 92545, and to provide an identification or description of the meter or instrument, the date of delivery, and the nature of the problem.

The Warranty provided above is the only Warranty made by McCrometer with respect to its products or any parts thereof and is made expressly in lieu of any other warranties, by course of dealing, usages of trade or otherwise, expressed or implied, including but not limited to any implied warranties of fitness for any particular purpose or of merchantability under the uniform commercial code. It is agreed this Warranty is in lieu of and buyer hereby waives all other warranties, guarantees or liabilities arising by law or otherwise. Seller shall not incur any other obligations or liabilities or be liable to buyer, or any customer of buyer for any anticipated or lost profits, incidental or consequential damages, or any other losses or expenses incurred by reason of the purchase, installation, repair, use or misuse by buyer or third parties of its products (including any parts repaired or replaced); and seller does not authorize any person to assume for seller any other liability in connection with the products or parts thereof. This Warranty cannot be extended, altered or varied except by a written instrument signed by seller and buyer.

This Warranty gives you specific legal rights, and you may also have other rights which vary from state to state.

McCrometer reserves the right to make improvements and repairs on product components which are beyond the Warranty period at the manufacturer's option and expense, without obligation to renew the expired Warranty on the components or on the entire unit. Due to the rapid advancement of meter design technology, McCrometer reserves the right to make improvements in design and material without prior notice to the trade.

All sales and all agreements in relation to sales shall be deemed made at the manufacturer's place of business in Hemet, California and any dispute arising from any sale or agreement shall be interpreted under the laws of the State of California.

MAIN LINE METER INDEX

I. UNCRATING

II. INSTALLATION

1. Flanged Tube Meters
2. Plain End Tube Meters
3. Welding Saddle Meters
 - A. Align
 - B. Scribe
 - C. Cut Out
 - D. Straightening Vanes
 - a.) Hold
 - b.) Mark
 - c.) Insert
 - E. Welding Saddle
 - F. Meter Assembly

III. METER SERVICE SCHEDULE

IV. METER HEAD ASSEMBLY

V. WORKING AREA

VI. TOTALIZER ASSEMBLY

1. Bonnet Mounting Screws
2. Totalizer
3. Totalizer Change Gears
4. Totalizer Drive Magnet

VII. GEARBOX

VIII. VERTICAL SHAFT ASSEMBLY

IX. MITER GEAR FRAME ASSEMBLY

1. Driven Miter Gear Assembly
2. Drive Miter Gear Assembly
3. Components

X. PROPELLER ASSEMBLY

1. Propeller Removal
2. Reverse Thrust Bearing Cartridge
3. Water Lubrication
4. Ceramic Bearing Cartridge
5. Spindle Ceramic Sleeve
6. Separator/Support Spindle Assembly
7. Propeller Installation
8. Thrust Bearing Cartridge Assembly
9. Propeller Bearing

XI. INSPECTION

XII. REASSEMBLY

1. Miter Gear Frame Assembly
2. Gearbox
3. Vertical Shaft Assembly
4. Totalizer Drive Magnet Assembly
5. Totalizer Base Cup
6. Bonnet Assembly
7. Propeller Assembly
8. Meter Head O-Ring

MAIN LINE METER INSTALLATION

I. UNCRATING. When uncrating the meter, any damage due to rough or improper handling should be reported to the transportation firm and McCrometer. If for any reason it is determined that the unit or parts of the unit should be returned to the factory, please contact McCrometer for clearance prior to shipment. Each unit must be properly crated to prevent any further damage. The factory assumes no responsibility for equipment damage in return shipment due to improper packaging. The shipping crate contains the following items:

Main Line Meter Assembly with

Standard Totalizer.....	1
Mounting Equipment as required.....	-
Operation and Maintenance Manual.....	1
Tool T-2402X-1.....	1

II. INSTALLATION of McCrometer Main Line Meters varies depending upon the type and model of meter selected for each application. The meter must have a full flow of liquid for proper accuracy. The meter installations fall into three basic categories:

1. FLANGED TUBE METERS can be installed exactly as you would install any short length of flanged pipe. Flanged ends are standard pattern and drilling for any meter size. Fully opened gate valves, fittings or other obstructions that tend to set up flow disturbances should be a minimum of five pipe diameters upstream and one pipe diameter downstream from the meter.

2. PLAIN END TUBE METERS can be installed similar to replacing a short length of plain end pipe in the line by either welding, or by using one of a variety of pipe couplings available. **Note:** Meter head assembly (#13) should be removed before welding (see step IV). Fully opened gate valves, fittings, or other obstructions that tend to set up flow disturbances should be a minimum of five pipe diameters upstream and one pipe diameter downstream from the meter.

3. WELDING SADDLE METERS can be installed on an existing pipeline by cutting a hole of proper size and welding a meter saddle (furnished with the meter) to the pipe. The installation steps outlined below should be followed carefully to achieve proper mounting of the meter:

A. ALIGN the cutout template in the desired position for the meter on the pipe. Make certain that the center line of the pipe and the center line marked on the template are parallel with each other. Some people prefer to use the saddle as the template.

B. SCRIBE the pipe along the line specified for your meter size cutout.

C. CUT OUT the section of pipe within the scribed line and remove all burrs, slag, and rough edges from the inside and outside of the cutout section.

D. STRAIGHTENING VANES are recommended when

there are less than ten pipe diameters of straight pipe (no fittings or obstructions) directly upstream from the meter location. Straightening vanes are available from the factory and, when required, should be installed in the following manner, prior to welding the saddle to the pipe:

- a.) **HOLD** the vanes on the outside of the pipe ten (10) inches upstream from the center of the cutout opening. The vanes must be parallel to the center line of the pipe and should be equally spaced radially 120 degrees apart.
- b.) **MARK** the pipe around the straightening vane bolts and drill holes for vane mounting (9/16" dia. hole for 4" through 12" meters or 11/16" dia. holes for 14" through 20" meters).
- c.) **INSERT** the vanes into the pipe through the cutout opening after installing the brass and stainless/rubber washers over the vane bolts. The brass washer should be installed against the vane bolt head with the stainless/rubber washer installed against the brass washer (rubber side away from vane). Position the vanes inside the pipe with the bolts protruding through the vane mounting bolt holes. Place stainless/rubber washers over each bolt, rubber against the pipe. The brass washer should be placed between the stainless/rubber washer and the vane mounting nut. Secure nuts to hold the vanes to the pipe (approx. 60 ft./lbs torque). The vanes can be welded to the pipe, if desired; however, the washers should not be used. **Note:** Meter head assembly (#13) should be removed before welding (see step IV).

E. WELDING SADDLE should be centered over the cutout section of the pipe. Make certain that no part of the pipe protrudes past the inside edge of the welding saddle. Tack weld the saddle to the pipe prior to welding a continuous bead around the saddle. **Note:** Meter head assembly (#13) should be removed before welding (see step IV).

F. METER ASSEMBLY should be placed in the line with the propeller nose facing the upstream flow in the pipe. Use care when installing the meter not to damage the propeller as it passes through the saddle opening. The meter head o-ring should be covered with a thin coat of grease before installing the meter. Tighten the meter head bolts securely.

MAIN LINE METER OPERATION AND MAINTENANCE MANUAL

III. MCCROMETER products have been carefully designed to be as maintenance free as possible. Periodic preventive maintenance, however, is highly recommended and should be practiced according to schedule to ensure continuous accuracy and trouble-free performance of your propeller meters. The maintenance and inspection procedure can also be used as a guide to locating a problem in the unit that may be the cause of abnormal meter operation.

Routine preventative maintenance should be performed on all meters, including cleaning and an inspection of the propeller and bearing. The interval between inspections depends on the water quality and the usage of the meter. The initial inspection should be performed after one to two years of service, to determine the period between future inspections. After five to ten years, the complete meter should be inspected to ensure years of dependable service.

IV. METER HEAD ASSEMBLY (#13) should be removed from the service line by removing the meter head bolts (#51) and lifting up the rear (downstream) portion of the meter head (#13) carefully pulling the assembly back (downstream) and up at the same time to allow the propeller (#38) to clear the inside of the meter saddle and be lifted free. Inspect the meter head o-ring (#50) for any sign of damage and replace if necessary. Replace the meter head assembly (#13) with a dummy cover plate if the service line is to remain in operation. **Note:** Due to the limited clearance on an 8 inch size meter a different removal procedure is used:

- a) Remove the meter head bolts (#51).
- b) Lift the meter assembly and tilt it forward.
- c) Slide the assembly back out of the saddle opening. The propeller may have to be rotated in order to fit through the saddle opening.

V. WORKING AREA chosen for disassembly and reassembly of the internal meter components should be clean to reduce the chance of dust or dirt particles being introduced into the meter mechanism.

VI. TOTALIZER ASSEMBLY (#4) service procedure should include cleaning and inspection of the unit noting any excessive wear on the change gears (#7 & #8) that may lead to operational problems in the unit.

1. BONNET MOUNTING SCREWS (#3) should be removed and the entire bonnet (#1) lifted off the meter.

2. TOTALIZER is contained within the totalizer bonnet (#1) and held in place by a base cup (#5). It should not be necessary to remove the totalizer (#4) during inspection; however, removal of the base cup (#5) is necessary for inspection of the totalizer change gears (#7 & #8). Removal of the base cup (#5) can be accomplished by inserting a small screwdriver into the two cutouts and prying upward under the edge.

3. TOTALIZER CHANGE GEARS (#7 & #8) should be inspected for any sign of wear. Both the A-(drive) gear and B-(driven) gear are attached to the lower portion of the totalizer assembly (#4). Spin the floating totalizer driven magnet in the center of the totalizer bottom (#4) to make certain it spins freely without bind or drag. The bottom of the totalizer has the letter "A" molded next to the A-drive gear shaft, and the letter "B" next to the B-driven gear shaft.

4. TOTALIZER DRIVE MAGNET ASSEMBLY (#12) located in the meter head (#13) at the top of the vertical shaft assembly (#14) should be checked and adjusted if necessary to position it 1/16 inch below the top surface of the meter head (#13). Adjustments can be made by loosening the socket head set screw in the side of the totalizer drive magnet assembly (#12), and sliding it up or down the vertical shaft (#14) as needed, using tool 1-2710. Always be sure the set screw is tightened into the flat on the vertical shaft (#14).

VII. GEARBOX (#17) on McCrometer meters is sealed and filled with gearbox oil to ensure the long life and proper operation of the parts contained in the miter gear frame assembly (#26). Before disassembling the lower meter assembly, the oil must be emptied out of the gearbox (#17). Vertical shaft assembly (#14) must be removed before the gearbox oil can be drained.

VIII. VERTICAL SHAFT ASSEMBLY (#14) is pulled directly out the top of the meter after removing two screws (#16) inside the meter head (#13). Spin the upper bearing assembly (#15) gently, checking for any sign of wear. Inspect the vertical shaft assembly (#14) to be sure it is not bent or damaged. To drain gearbox oil, turn meter over onto the meter head (#13) and drain oil into a container.

IX. MITER GEAR FRAME ASSEMBLY (#26) can be pulled out of the back of the gearbox (#17) after removing four screws (#36). Spin the driven magnet (#29) to make sure the unit runs freely and inspect the teeth on both the drive (#31) and the driven (#32) miter gear assemblies for any sign of excessive wear. If the assembly spins freely and the miter gears (#31 & #32) are not worn, there should be no further inspection or disassembly of the unit. Should this service procedure show that the unit does not spin freely or that the miter gears (#31 & #32) are worn, the miter gear frame assembly (#26) should be disassembled as the following steps indicate and all worn or damaged parts replaced.

1. DRIVEN MITER GEAR ASSEMBLY (#32) can be removed by loosening the allen head set screw, located on the side of the gear hub, and pushing the driven miter gear shaft (#34) out of the assembly. Note the location of the shim washer (#33), if any, to be sure it is repositioned properly when reassembling the miter gear frame assembly (#26). When reassembling be sure the set screws go into recess in the miter gear shafts (#29 & #34), or damage could result. Be sure clevis end of the driven miter gear shaft (#34) is at the same end as the miter gear is located or the meter will subtract from the totalizer.

2. DRIVE MITER GEAR ASSEMBLY (#31) can be removed by loosening the allen head set screw, located on the side of the gear hub, and pulling the driven magnet and shaft assembly (#29) out the front of the miter gear frame (#26). Note any shim washer (#33) that may be positioned behind the drive miter gear (#31) when removing the shaft (#29).

3. COMPONENTS of the miter gear frame (#26) as well as the gearbox (#17) should be completely inspected at this point of disassembly. Each part of the miter gear frame assembly (#26) should be carefully inspected to determine the origin of any operational problem and those parts that are damaged or worn should be replaced. Clean the parts of the unit and reassemble reversing steps (1) and (2) above.

X. PROPELLER ASSEMBLY (#37) inspection includes cleaning the ceramic sleeve bearing (#39), separator assembly (#18), drive magnet (#41), and the propeller assembly (#38).

1. PROPELLER REMOVAL Loosen the set screw (#47) in the side of the nose of the propeller. Remove the thrust bearing cartridge (#48) by turning it counterclockwise while holding the propeller in place.

2. REVERSE THRUST BEARING CARTRIDGE (#44) must now be removed. Turn the propeller (#37) so that the allen wrench clearance hole is lined up with the set screw in the side of the reverse thrust bearing cartridge (#44). The location of the set screw is marked by a small hole drilled in the face of the reverse thrust bearing cartridge. With a 5/64 inch allen wrench, loosen the set screw (#45) in the reverse thrust bearing cartridge (#44) two to three turns, which will allow the cartridge to be unscrewed without damaging the spindle thread. **Note:** If the bearing area appears to be clogged with dirt or sediment, making it difficult to locate the set screw (#45) or to allow the allen wrench to fit into the set screw socket, then the bearing area should be flushed out with water. Insert Tool T-2402X-1 into the propeller through the threaded nose. The tabs in the tool should engage in the screwdriver slot in the end of the reverse thrust bearing cartridge (#44). Remove the propeller assembly (#37) and reverse thrust bearing cartridge (#44) by turning Tool T-2402X-1 counterclockwise unscrewing the reverse thrust bearing cartridge (#44) from the spindle (#18). The propeller assembly with reverse flow cartridge will now slide off the spindle. **WARNING:** If the reverse thrust cartridge does not unscrew easily, it may be because the set screw was not unscrewed enough. If unscrewing the reverse flow cartridge is continued with the set screw binding on spindle thread, damage to thread could occur.

3. WATER LUBRICATION of the ceramic sleeve bearing (#39) is achieved by means of two openings in the end of the thrust bearing cartridge (#48) which allows air to be purged from the bearing area. These should be cleared of any foreign material by running a small wire through the holes on either side of the screwdriver slot.

4. CERAMIC BEARING CARTRIDGE (#39) and drive magnet (#41) should be cleaned of any foreign material and inspected for damage. Using a bottle brush, thoroughly clean the ceramic bearing surface (#39) and the magnet inside diameter (#41). After cleaning the propeller, flush the inside out with water. The outside surfaces of the propeller should also be cleaned to assure a smooth, unrestricted flow across the surface of the propeller.

Do not use an oil-based solvent in cleaning, as damage to the assembly could occur.

5. SPINDLE CERAMIC SLEEVE (#20) and the O.D. or surface of the separator (#18) should be cleaned and inspected for any substantial amount of wear. The thrust bearing (#48) should be checked for any damage. If it is determined that the spindle ceramic sleeve (#20) or separator (#18) are worn sufficiently, the separator/support spindle assembly (#18) should be replaced.

6. SEPARATOR/SUPPORT SPINDLE ASSEMBLY (#18) can be removed for replacement by removing the four mounting screws (#21) which thread into the gear box. Separator o-ring (#22) should be replaced and the new o-ring (#22) covered with a thin coat of silicone grease. The separator/support spindle assembly (#18) can then be replaced in the front of the gear box (#17) with a firm push, gently rotating the assembly at the same time. Replace and tighten the four mounting screws (#21).

7. PROPELLER INSTALLATION is accomplished by following these steps:

- a) The reverse thrust cartridge set screw (#45) should be protruding out of the reverse thrust bearing cartridge so it will not bind up on the spindle thread. **Note:** Look through the end of the propeller and hole in the reverse thrust cartridge to be sure the set screw is not showing.
- b) Slide the propeller assembly onto the support spindle (#18) until the reverse thrust bearing cartridge (#44) contacts the threads on the end of the spindle (#18). Using Tool T-2402X-1, thread the reverse thrust bearing cartridge onto the spindle. If you feel any resistance when threading the reverse thrust cartridge on, stop at once and check to be sure the set screw is not binding on the thread. Be careful not to cross-thread the reverse thrust bearing cartridge. Thread the reverse thrust bearing cartridge (#44) onto the spindle (#18) until the trailing edge of the propeller contacts the gear box (#17). Set the proper end play by inserting a 5/64" allen wrench into the reverse thrust bearing set screw (through the side of the propeller) and loosen the reverse thrust bearing cartridge (#44) 1/2 turn counterclockwise. Tighten the set screw in reverse thrust bearing cartridge. There should be approximately .020" clearance between the gear box (#17) and trailing edge of the propeller when the propeller is pulled forward (away from the gear box). The propeller must not contact the gear box.

8. THRUST BEARING CARTRIDGE ASSEMBLY (#48) should be inspected for damage and replaced in the nose of the propeller. The thrust bearing cartridge (#48) is used to adjust the amount of longitudinal end play of the propeller assembly on its spindle (#18), which should be about 1/64 inch. End play can be adjusted by turning the thrust bearing cartridge assembly (#48) clockwise until it tightens against the end of the support spindle (#18), then turning thrust bearing cartridge (#48) counterclockwise 1/8 of a turn. Tighten set screw (#47). Check the longitudinal end play of the propeller to ensure it's

not excessive and does not allow the propeller (#37) to contact the gear box (#17). Check the clearance between the propeller (#37) and gear box (#17). The clearance should be approximately .010" between the gear box (#17) and trailing edge of the propeller when the propeller is pushed back (toward the gear box). The propeller assembly (#37) must spin freely.

9. PROPELLER BEARING (#39) can be checked for excessive radial play by rocking the propeller (#37) gently from side to side on the spindle (#18). Some play is required for proper operation of the water lubricated ceramic sleeve bearing.

XI.INSPECTION of all internal meter parts that may be replaced in the field has been accomplished at this point. Should any of the meter parts, upon inspection, appear to be damaged or excessively worn, they must be replaced to ensure proper meter operation and prevent further damage.

XII.REASSEMBLY is necessary at this point. Before reassembling any parts, make certain that each is cleaned of any dust or dirt and properly lubricated. Costs for replacement parts not covered by warranty are available from the current parts and price list. If it is determined that the meter should be returned for repair, please notify McCrometer prior to shipment. Each meter must be properly packaged to prevent damage to the meter in shipment.

1. MITER GEAR FRAME ASSEMBLY (#26) can be replaced in the back of the gearbox (#17) with a firm push, gently rotating the assembly at the same time. Replace the miter gear frame o-ring (#35) and cover the new o-ring with a thin coat of silicone grease before replacing the assembly (#26). Make certain that the assembly is installed in a position such that the drive clevis portion of the driven miter gear shaft (#34) can accept the driven clevis portion of the vertical shaft assembly (#14). Secure with four mounting screws (#36).

2. GEARBOX (#17) must be filled with one ounce of 10w mineral oil. A small funnel or an oil can with a small nozzle will make filling the gearbox (#17) easier. Pour the oil through the opening in the top of the meter head (#13).

3. VERTICAL SHAFT ASSEMBLY (#14) should be inserted gently into the gearbox (#17) through the opening in the top of the meter head (#13). Rotate the shaft gently until it is engaged in the driven miter gear shaft (#34) of the miter gear frame assembly (#26). Replace and secure two screws (#16) that hold the upper bearing (#15) in place. Do not overtighten the screws (#16) as this could cock the bearing (#15) and bind the vertical shaft (#14). Turn the top of the vertical shaft (#14) to check for any bind or drag. Should any bind or drag be apparent, it can usually be corrected by adjusting the vertical shaft collar and bearing assembly (#15). Loosen the set screw (#16) in the side of the assembly (#15) and slide the shaft (#14) downward until it rests against the driven miter gear shaft (#34), then lift up about 1/64

inch. Tighten set screw (#16).

4. **TOTALIZER DRIVE MAGNET ASSEMBLY (#12)** should be checked again to make certain it is properly set to drive the totalizer (#4) (see step VI, 4).
5. **TOTALIZER BASE CUP (#5)** can be placed back in the totalizer bonnet (#1) on the totalizer assembly (#4) after the desiccant capsule and the base cup o-ring (#6) are replaced. Be sure o-ring (#6) is on base cup (#5) properly.
6. **BONNET ASSEMBLY (#1)** should be cleaned and replaced on the meter head (#13). Bonnet o-ring (#2) should be replaced and the new o-ring (#2) covered with a thin coat of silicone grease. Secure with four screws (#3).
7. **PROPELLER ASSEMBLY (#37)** should be dipped in water to lubricate the propeller ceramic sleeve bearing (#39). Spin the propeller (#38) gently to make certain the meter operates smoothly and no bind or drag is apparent.
8. **METER HEAD O-RING (#50)** should be inspected for any sign of damage and covered with a thin coat of silicone grease. The meter can now be installed in the service line. When replacing the meter on the line, make certain that the top of the welding saddle is smooth and free of any foreign material. Make certain that no foreign materials are attached to the inside of the service line pipe, as any flow disturbance or obstruction may affect the accuracy of the meter.

NOTES

2" - 20" MAIN LINE METERS

MODELS ML03, ML07, ML11, ML15, ML19, ML21, MLT1

PARTS LIST

NO.	QTY.	PART NUMBER	DESCRIPTION
	1	7-MLT1-*	MAIN LINE METER HEAD ASSEMBLY
	1	6-4260	TOTALIZER & BONNET COMPLETE (ITEMS 1 THRU 6)
	1	7-4260	TOTALIZER & BONNET COMPLETE (ITEMS 1 THRU 8)
1	1	5-4316	TOTALIZER BONNET ASSEMBLY
	1	1-4317-2	TOTALIZER BONNET LID (W/PIN)
2	1	1-1551-38	O-RING, TOTALIZER BONNET
3	4	1-1115-10-10	SCREW, BONNET MOUNTING (ea.)
4	1	5-4260	TOTALIZER ASSEMBLY (SPECIFY DIAL)
	1	1-2310-‡	DIAL (AS SPECIFIED)
	2	1-1118-3-3	SCREW, DIAL MOUNTING (ea.)
	1	1-4276	SWEEP HAND
5	1	1-4318	BASE CUP, TOTALIZER
6	1	1-1551-17	O-RING, BASE CUP
7	1	3-4045	A-GEAR ASSEMBLY (SPECIFY # OF TEETH)
8	1	3-4045	B-GEAR ASSEMBLY (SPECIFY # OF TEETH)
12	1	3-2324	DRIVE MAGNET ASSEMBLY, TOTALIZER
13	1	3-2101-‡‡	METER HEAD (SIZES 2" THRU 12")
	1	2-2101-14	METER HEAD (SIZES 14" THRU 20")
14	1	2-2520-*	VERTICAL SHAFT
15	1	3-2352	VERTICAL SHAFT COLLAR & BEARING ASSEMBLY
16	2	1-1113-6-4	SCREW, VERTICAL SHAFT COLLAR & BEARING MTG. (ea.)
17	1	3-2394-*.304	GEARBOX
18	1	4-2455-2	SEPARATOR/SUPPORT SPINDLE ASSEMBLY
20	1	1-1508-20	CERAMIC SLEEVE FOR SUPPORT SPINDLE
21	4	1-1103-8-7	SCREW, SEPARATOR/SPINDLE MOUNTING (ea.)
22	1	1-1551-24	O-RING, SEPARATOR/SPINDLE
23	1	10110-10	O-RING, GEARBOX
24	4	1-1251-5-12	BOLT, GEARBOX MOUNTING (ea.)
25	-	1-1806	VIBRA-TITE, GEARBOX MOUNTING BOLT
26	1	4-2347	MITER GEAR FRAME ASSEMBLY (ITEMS 27 THRU 35)
27	1	2-2347	MITER GEAR FRAME
28	4	1-1504-2	BEARING, MITER GEAR FRAME (ea.)
29	1	3-2348	DRIVEN MAGNET & SHAFT ASSEMBLY
30	1	1-2354-P	DRIVEN MAGNET SPACER
31	1	3-2349	DRIVE MITER GEAR ASSEMBLY
32	1	3-2137	DRIVEN MITER GEAR ASSEMBLY
33	2	2-2148-1	SHIM WASHER (ea.)
34	1	2-2138	DRIVEN MITER GEAR SHAFT
35	1	1-1551-2	O-RING MITER GEAR FRAME
36	4	1-1103-8-7	SCREW, MITER GEAR FRAME MOUNTING (ea.)
37	1	5-2425-‡-PT	PROPELLER ASSEMBLY (ITEMS 38 THRU 48)
38	1	3-2425-‡-P	PROPELLER
39	1	2-2426-P-1	CERAMIC BEARING CARTRIDGE ASSEMBLY
40	1	1-1116-8-6	SCREW, CERAMIC BEARING CARTRIDGE MTG.
41	1	2-1601-2	DRIVE MAGNET
42	1	1-2428-‡	DRIVE MAGNET RETAINING PLATE
43	2	1-1115-3-18	SCREW, DRIVE MAGNET RETAINING PLATE (ea.)
44	1	3-2402-2	REVERSE THRUST BEARING CARTRIDGE ASSEMBLY
45	1	1-1101-8-5	SET SCREW, REVERSE THRUST BEARING
46	2	1-1509-1	CERAMIC THRUST BEARING, 3/16" DIA (ea.)
47	1	1-1125-6	SET SCREW, NYLON POINT
48	1	3-2356	THRUST BEARING CARTRIDGE ASSEMBLY
49	2	1-1510-1	CERAMIC THRUST BEARING, 1/4" DIA. (ea.)
50	1	1-1552-‡‡‡	O-RING, METER HEAD
51	8	1-1251-8-24	BOLT, METER HEAD (ea.)
52	8	1-1301-14	WASHER, METER HEAD (ea.)
-	-	1-1804-2-16	GEARBOX OIL (16 OZ.)
-	1	1-1607-5	DESICCANT CAPSULE

* INSERT METER SIZE TO COMPLETE PART NUMBER

‡ CONSULT FACTORY TO COMPLETE PART NUMBER

‡‡ 2" - 8" INSERT -3 OR 10" - 12" INSERT -10

‡‡‡ 2" - 8" INSERT -1, 10" - 12" INSERT -2, 14" - 20" INSERT -3

CONSULT FACTORY FOR PRICES.**When ordering replacement parts, please specify:**

● Meter Size ● Meter Model Meter ● Serial Number

2" - 20" MAIN LINE METERS
MODELS ML03, ML07, ML11, ML15, ML19, ML21, MLT1

***STANDARD TOTALIZER ASSEMBLY**

***CERAMIC BEARING CARTRIDGE PROPELLER**

***ONE PIECE SEPARATOR/SPINDLE AND THREADED REVERSE THRUST BEARING CARTRIDGE**

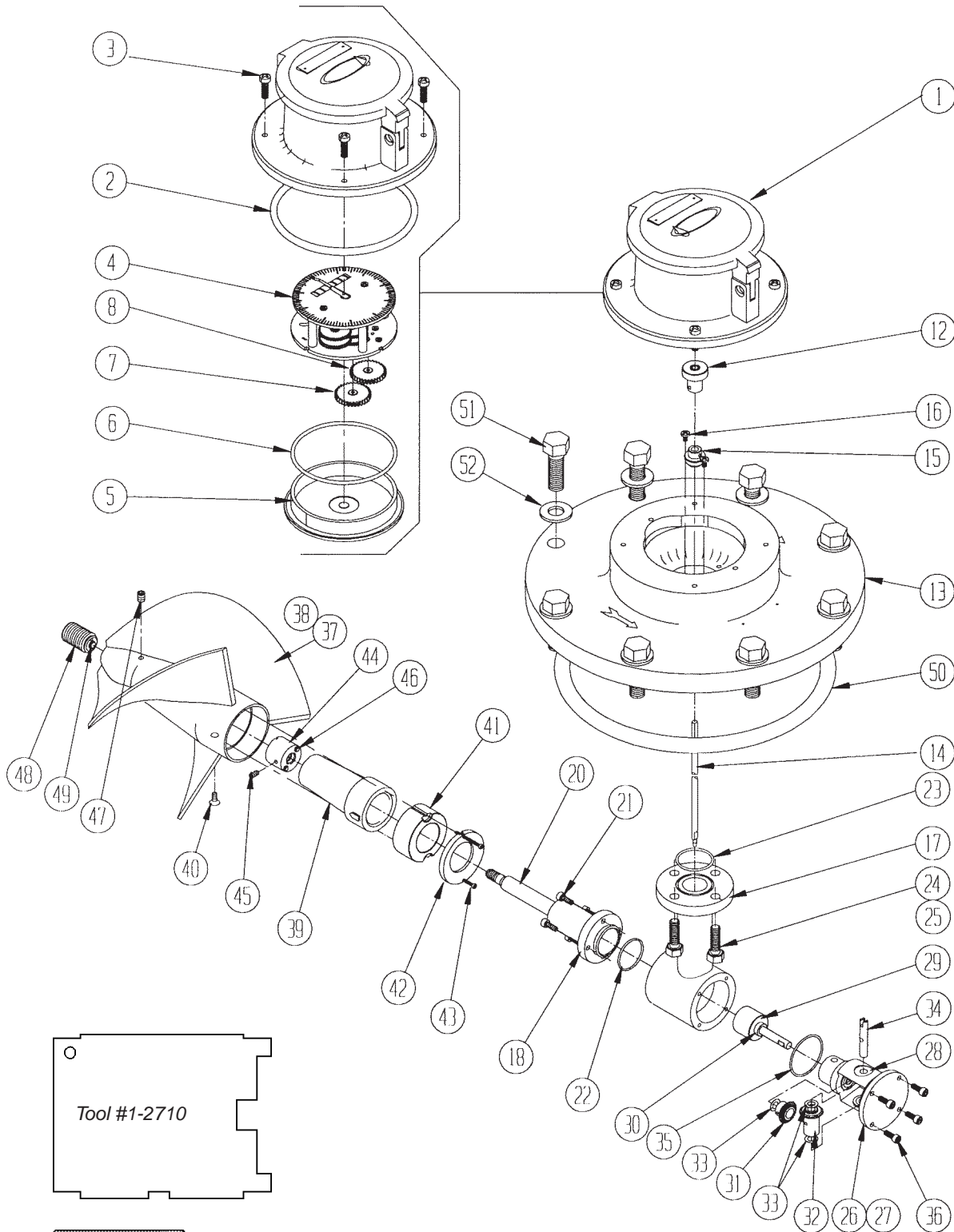

MAIN LINE METER INSTALLATION INSTRUCTIONS

1

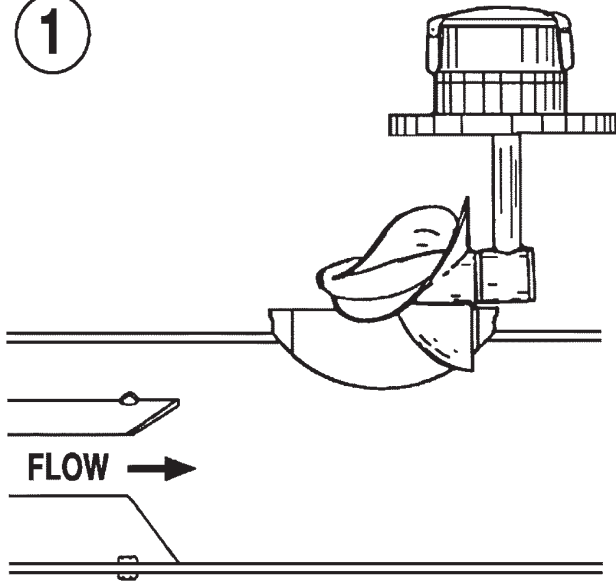

1. Set meter assembly on saddle as shown with one propeller blade pointing down. Propeller should point opposite the direction of flow.

2

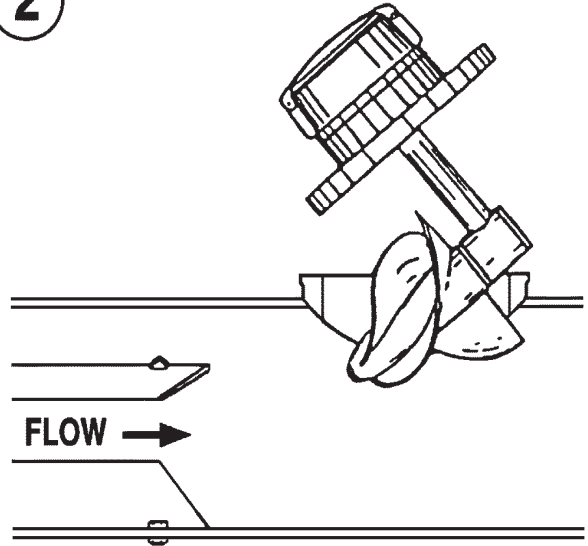

2. Tilt the meter head assembly forward allowing the propeller to move through the opening.

3

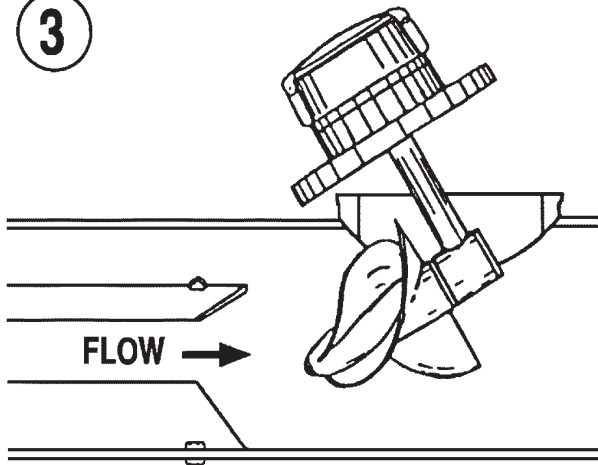

3. Slide the assembly forward and down. The propeller may have to be rotated in order to fit through the saddle opening.

4

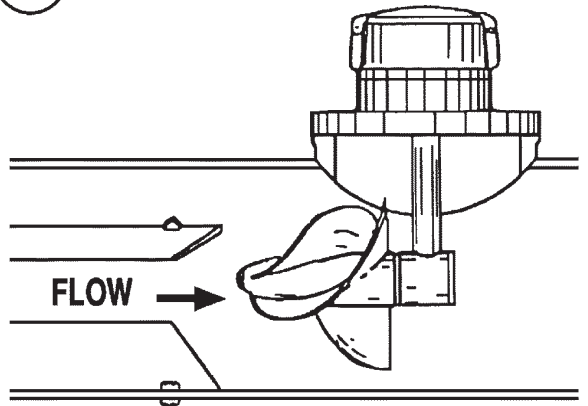

4. Allow the meter head assembly to come to rest on the saddle. Install bolts and tighten to proper torque.

WARNING:

BEFORE REMOVING THE METER HEAD FROM THE PIPELINE THE WATER MUST BE TURNED OFF AND PRESSURE MUST BE RELIEVED FROM THE LINE. SERIOUS INJURY CAN RESULT FROM REMOVING A METER HEAD UNDER PRESSURE.

METER SHOULD NOT BE TURNED UPSIDE DOWN AS OIL WILL DRAIN OUT OF THE GEARBOX AND NOT PROVIDE PROPER LUBRICATION TO THE MITER GEARS AND BEARINGS.