

Legend

(Note: All items may not appear on drawing)

- Keypad
- San. Sewer Manhole
- Water Manhole
- Storm Drain Manhole
- Electrical Manhole
- Catch Basins
- Exist. Fire Hydrant
- Fire Hydrant
- Exist. Water Valve
- Water Valve
- Sanitary Sewer
- Culinary Water
- Gas Line
- Irrigation Line
- Storm Drain
- Telephone Line
- Secondary Waterline
- Power Line
- Fire Line
- Land Drain
- Power pole
- Power pole w/guy
- Light Pole
- Fence
- Flowline of ditch
- Overhead Power line
- Corrugated Metal Pipe
- Concrete Pipe
- Reinforced Concrete Pipe
- Ductile Iron
- Polyvinyl Chloride
- Top of Asphalt
- Edge of Asphalt
- Centerline
- Flowline
- Finish Floor
- TC
- Top of Curb
- Top of Wall
- TK
- Top of Walk
- Top of Concrete
- TEN
- Natural Ground
- NG
- Finish Grade
- FG
- Fire Department Connection
- FDC
- Finish Contour
- 90
- Exist. Contour
- 95.3374
- Finish Grade
- 95.721A
- Exist. Grade
- R
- Ridge Line
- Direction of Flow
- Unused Space
- Existing Asphalt
- New Asphalt
- Heavy Duty Asphalt
- Concrete
- Spill
- Curb & Gutter
- Demo Tree

NO.	DESCRIPTION	DATE	REV

GREAT BASIN ENGINEERING

5746 SOUTH 1475 EAST OGDEN, UTAH 84403
 MAIN (801) 994-4515 S.L.C. (801) 521-0222 FAX (801) 399-7544
 WWW.GREATBASINENGINEERING.COM

Site Plan

Weber Storage Sheds

1957 N. Rulon White Blvd.
 Ogden City, Weber County, Utah
 A part of Section ??, T2N, R2W, SL&M, U.S. Survey

Jan, 2022

SHEET NO.

C1

21N713

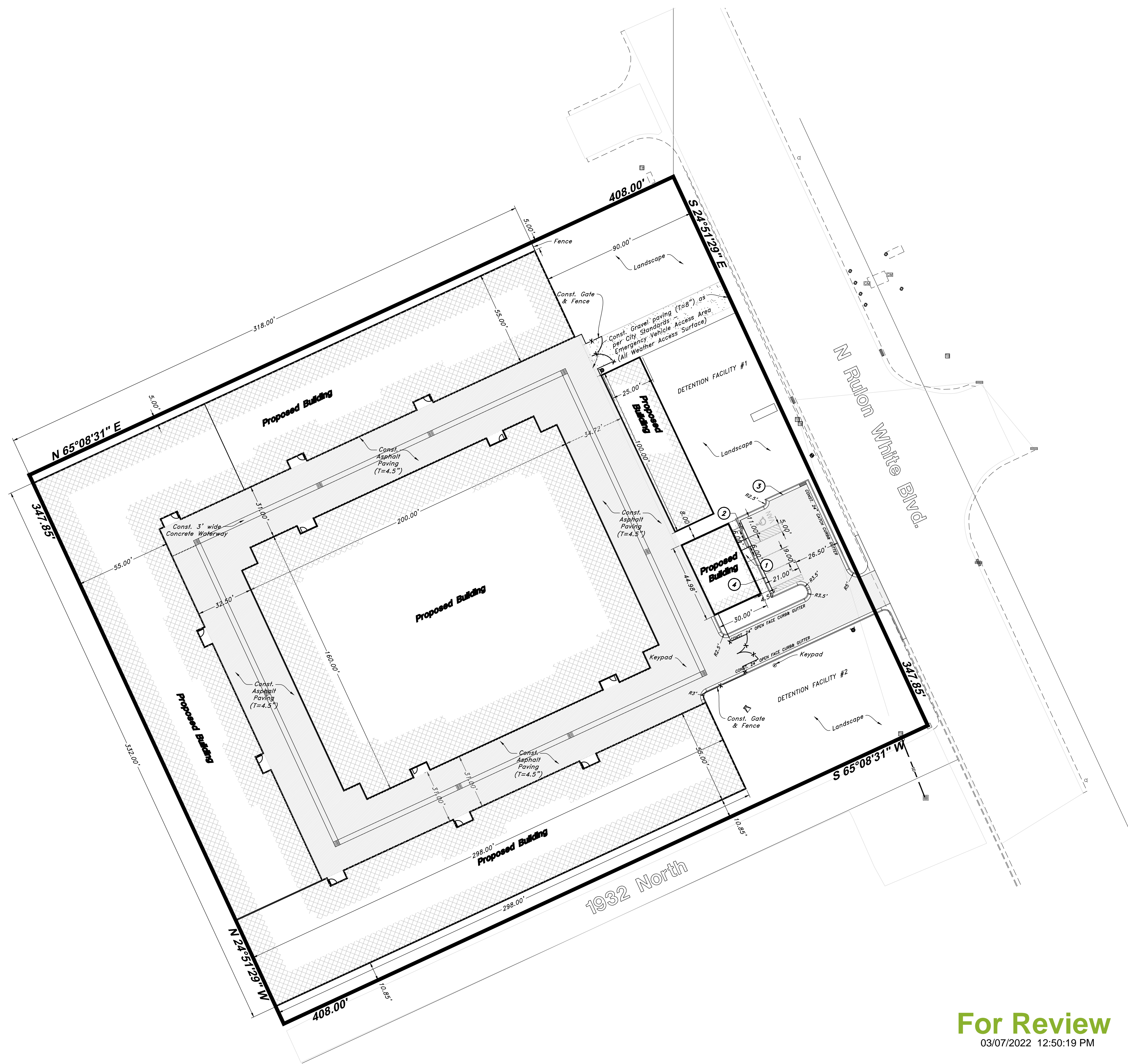

SITE KEY NOTES

- 1 - Const. Accessible ramp
- 2 - Const. Accessible parking sign
- 3 - Const. 24" Catch Curb & Gutter
- 4 - Const. 24" Open Face Curb & Gutter

GENERAL SITE NOTES:

1. Stalls designated as accessible will require a painted accessible symbol and sign. (See Details)
2. Fire lane markings and signs to be installed as directed by the Fire Marshall. Road widths equal to or less than 32 feet shall require red curbside painting and "No Parking" signs that are approved positioned along the fire apparatus access routes. (See detail on sheet CDS03).
3. Aisle markings, directional arrows and stop bars will be painted at each driveway as shown on the plans.
4. Building sidewalks, ramps, and bollards are building contractor responsible items. See architectural plans.
5. All dimensions are to back of curb unless otherwise noted.
6. Fire hydrants and access roads shall be installed prior to construction of any buildings. All fire hydrants shall be placed with the 4 1/2" connection facing the point of access for Fire Department Apparatus.
7. All fire apparatus access roads shall be a minimum all-weather, drivable and maintainable surface. There shall be a minimum clear and unobstructed width of not less than 26 feet and an unobstructed vertical clearance of not less than 13 feet 6 inches. Dead-end roads created in excess of 150 feet in length shall be provided with an approved turn-around.

PRIVATE ENGINEER'S NOTICE TO CONTRACTORS

The Contractor agrees that he shall assume sole and complete responsibility for job site conditions during the course of construction of this project, including safety of all persons and property; that this requirement shall apply continuously and not be limited to normal working hours; and that the contractor shall defend, indemnify, and hold the owner and the engineer harmless from any and all liability, real or alleged, in connection with the performance of work on this project, excepting for liability arising from the sole negligence of the owner or the engineer.

ALL CONSTRUCTION TO CONFORM TO WEBER COUNTY STANDARDS AND SPECIFICATIONS IN RIGHT OF WAY

SITE DATA

Parcel Area 141,923 sq.ft. or 3.258 Acres
 Impervious Surface Area 113,487 sq.ft. or 2.605 Acres
 Building Area 77,089 sq.ft. or 1.769 Acres
 Pervious Surface Area 28,435 sq.ft. (20%)
 Up to 50% of Pervious Surface will be irrigated the remaining area will be xeriscaped with rock and/or 0 Water Plantings

Parking

- 4 Standard Stalls
- 1 ADA Stall
- 5 Total Stalls

For Review
 03/07/2022 12:50:19 PM

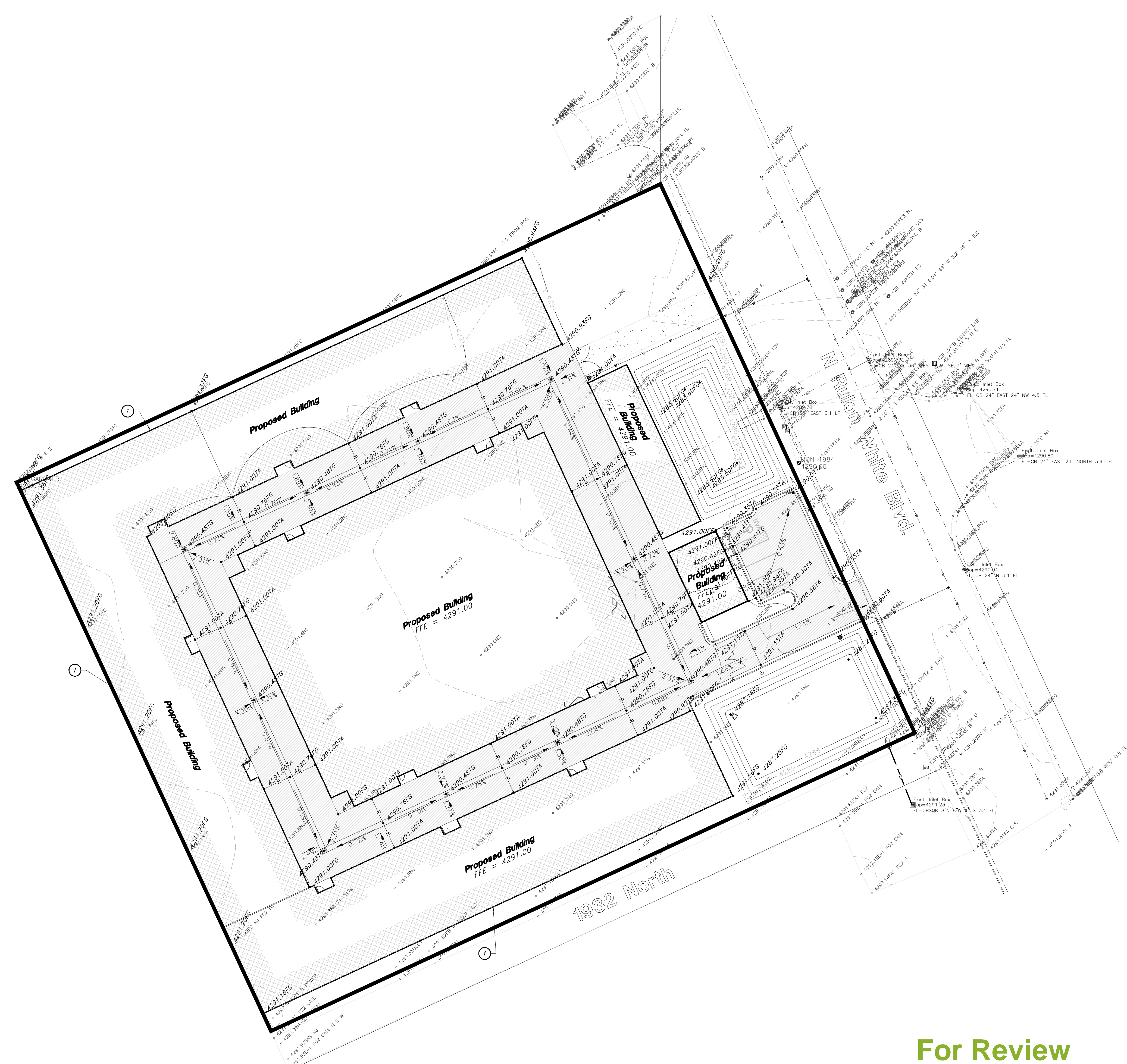

Legend
(Note: All items may not appear on drawing)

Keypad	(K)
San. Sewer Manhole	(S)
Water Manhole	(W)
Storm Drain Manhole	(SD)
Electrical Manhole	(E)
Catch Basins	(CB)
Exist. Fire Hydrant	(FH)
Fire Hydrant	(F)
Exist. Water Valve	(WV)
Water Valve	(V)
Sanitary Sewer	(SS)
Gravity Water	(GW)
Gas Line	(G)
Irrigation Line	(IR)
Storm Drain	(SD)
Telephone Line	(TL)
Secondary Waterline	(SW)
Power Line	(P)
Fire Line	(FL)
Land Drain	(LD)
Power pole w/guy	(PP)
Light Pole	(LP)
Fence	(F)
Flowline of ditch	(FD)
Overhead Power line	(OP)
Corrugated Metal Pipe	(CMP)
Concrete Pipe	(CP)
Reinforced Concrete Pipe	(RCP)
Ductile Iron	(DI)
Polyvinyl Chloride	(PVC)
Top of Asphalt	(TA)
Edge of Asphalt	(EA)
Centerline	(CL)
Flowline	(FL)
Finish Floor	(FF)
Top of Curb	(TC)
Top of Wall	(TW)
Top of Walk	(TW)
Top of Concrete	(TCM)
Natural Ground	(NG)
Finish Grade	(FG)
Fire Department Connection	(FDC)
Finish Contour	(FC)
Exist. Contour	(EC)
Finish Grade	(FG)
Exist. Grade	(EG)
Ridge Line	(RL)
Direction of Flow	(DF)
Unused Space	(US)

Existing Asphalt
New Asphalt
Heavy Duty Asphalt
Concrete
Spill
Curb & Gutter
Demo Tree

- GENERAL GRADING NOTES:**
- All work shall be in accordance with the City Public Works Standard.
 - Cut slopes shall be no steeper than 2 horizontal to 1 vertical.
 - Fill slopes shall be no steeper than 2 horizontal to 1 vertical.
 - Fills shall be compacted per the recommendations of the geotechnical report prepared for the project and shall be certified by the geotechnical engineer.
 - Areas to receive fill shall be properly prepared and approved by the City inspector and geotechnical Engineer prior to placing fill.
 - Fills shall be benched into competent material as per specifications and geotechnical report.
 - All trench backfill shall be tested and certified by the site geotechnical engineer per the grading code.
 - A geotechnical engineer shall perform periodic inspections and submit a complete report and map upon completion of the rough grading.
 - The final compaction report and certification from the geotechnical engineer shall contain the type of field testing performed. Each test shall be identified with the method of obtaining the in-place density, whether sand cone or drive ring and shall be so noted for each test. Sufficient maximum density determinations shall be performed to verify the accuracy of the maximum density curves used by the field technician.
 - Dust shall be controlled by watering.
 - The location and protection of all utilities is the responsibility of the permittee.
 - Approved protective measures and temporary drainage provisions must be used to protect adjoining properties during the grading project.
 - All public roadways must be cleared daily of all dirt, mud and debris deposited on them as a result of the grading operation. Cleaning is to be done to the satisfaction of the city engineer.
 - The site shall be cleared and grubbed of all vegetation and deleterious matter prior to grading.
 - The contractor shall provide shoring in accordance with OSHA requirements for trench walls.
 - Aggregate base shall be compacted per the geotechnical report prepared for the project.
 - Elevations shown on this plan are finish grades. Rough grades are the subgrades of the improvements shown hereon.
 - The recommendations in the following Geotechnical Engineering Report by xxxx are included in the requirements of grading and site preparation.
The report is titled "GEOTECHNICAL INVESTIGATION"
Job No.: _____ Address _____
 - As part of the construction documents, owner has provided contractor with a topographic survey performed by manual or aerial means. Such survey was prepared for project design purposes and is provided to the contractor as a courtesy. It is expressly understood that such survey may not accurately reflect existing topographic conditions.
 - Erosion Control: Protect all inlet boxes, catch basins, etc. with straw bales or other approved method to strain the storm water during construction. Protect surrounding properties and streets from site runoff with sandbags and earth berms.

- CURB AND GUTTER CONSTRUCTION NOTES:**
- Open face gutter shall be constructed where drainage is directed away from curb.
 - Open face gutter locations are indicated by shading and notes on site and grading plan.
 - It is the responsibility of the surveyor to adjust top of curb grades at the time construction staking.
 - Refer to the typical details for a standard and open face curb and gutter for dimensions.
 - Transitions between open face and standard curb and gutter are to be smooth. Hand form these areas if necessary.
- ADA NOTES:**
- Contractor must maintain a running slope on Accessible routes no steeper than 5.0% (1:20). The cross slope for Accessible routes must be no steeper than 2.0% (1:50). All Accessible routes must have a minimum clear width of 36". If grades on plans do not meet this requirement notify Consultants immediately.
- The Client, Contractor, and Subcontractor should immediately notify the Consultant of any conditions of the project that they believe do not comply with the current state of the ADA and/or FHAA.

PRIVATE ENGINEER'S NOTICE TO CONTRACTORS

The Contractor agrees that he shall assume sole and complete responsibility for job site conditions during the course of construction of this project, including safety of all persons and property; that this requirement shall apply continuously and not be limited to normal working hours; and that the contractor shall defend, indemnify, and hold the owner and the engineer harmless from any and all liability, real or alleged, in connection with the performance of work on this project, excepting for liability arising from the sole negligence of the owner or the engineer.

ALL CONSTRUCTION TO CONFORM TO WEBER COUNTY STANDARDS AND SPECIFICATIONS IN RIGHT OF WAY

For Review
03/07/2022 12:50:21 PM

Key notes:

- Construct heightened stem wall at the rear face of building.
Finished grade meets building above finished floor.

GREAT BASIN ENGINEERING

574 SOUTH 1475 EAST, OGDEN, UTAH 84403
MAIN (801)394-4515, SUC (801)321-0222, FAX (801)392-7544
WWW.GREATBASINENGINEERING.COM

Grading Plan

Weber Storage Sheds

1957 N. Rulon White Blvd.
Ogden City, Weber County, Utah
A part of Section ??, T2N, R2W, SLB&M, ULS. Survey

Jan, 2022

SHEET NO.

C2

21N713

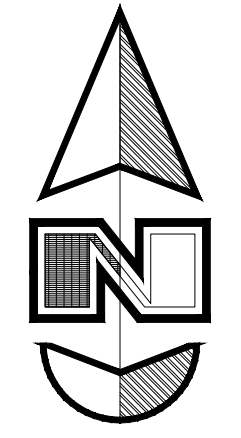

Scale: 1" = 30'

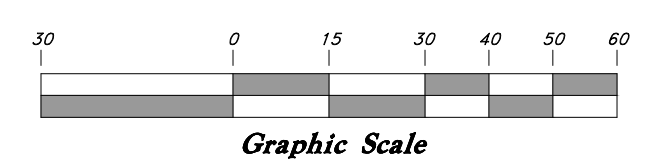

Legend

(Note: All items may not appear on drawing)

Keypad	(K)
San. Sewer Manhole	(S)
Water Manhole	(W)
Storm Drain Manhole	(SD)
Electrical Manhole	(E)
Catch Basins	(CB)
Exist. Fire Hydrant	(FH)
Fire Hydrant	(F)
Exist. Water Valve	(WV)
Water Valve	(V)
Sanitary Sewer	(SS)
Culinary Water	(CW)
Gas Line	(G)
Irrigation Line	(I)
Storm Drain	(SD)
Telephone Line	(TL)
Secondary Waterline	(SW)
Power Line	(P)
Fire Line	(FL)
Land Drain	(LD)
Power pole w/guy	(PP)
Light Pole	(LP)
Fence	(FENCE)
Flowline of ditch	(DHP)
Overhead Power line	(CMP)
Corrugated Metal Pipe	(CP)
Concrete Pipe	(CCP)
Reinforced Concrete Pipe	(RCP)
Ductile Iron	(DI)
Polyvinyl Chloride	(PVC)
Top of Asphalt	(TA)
Edge of Asphalt	(EA)
Centerline	(CL)
Flowline	(FL)
Finish Floor	(FF)
Top of Wall	(TW)
Top of Curb	(TCW)
Top of Walk	(TWK)
Top of Concrete	(TCN)
Natural Ground	(NG)
Finish Grade	(FG)
Fire Department Connection	(FDC)
Finish Contour	(FC)
Exist. Contour	(EC)
Finish Grade	(FG)
Exist. Grade	(EG)
Ridge Line	(RL)
Direction of Flow	(DF)
Unused Space	(US)
Existing Asphalt	(EA)
New Asphalt	(NA)
Heavy Duty Asphalt	(HDA)
Concrete	(C)
Spill	(S)
Curb & Gutter	(CG)
Demo Tree	(DT)

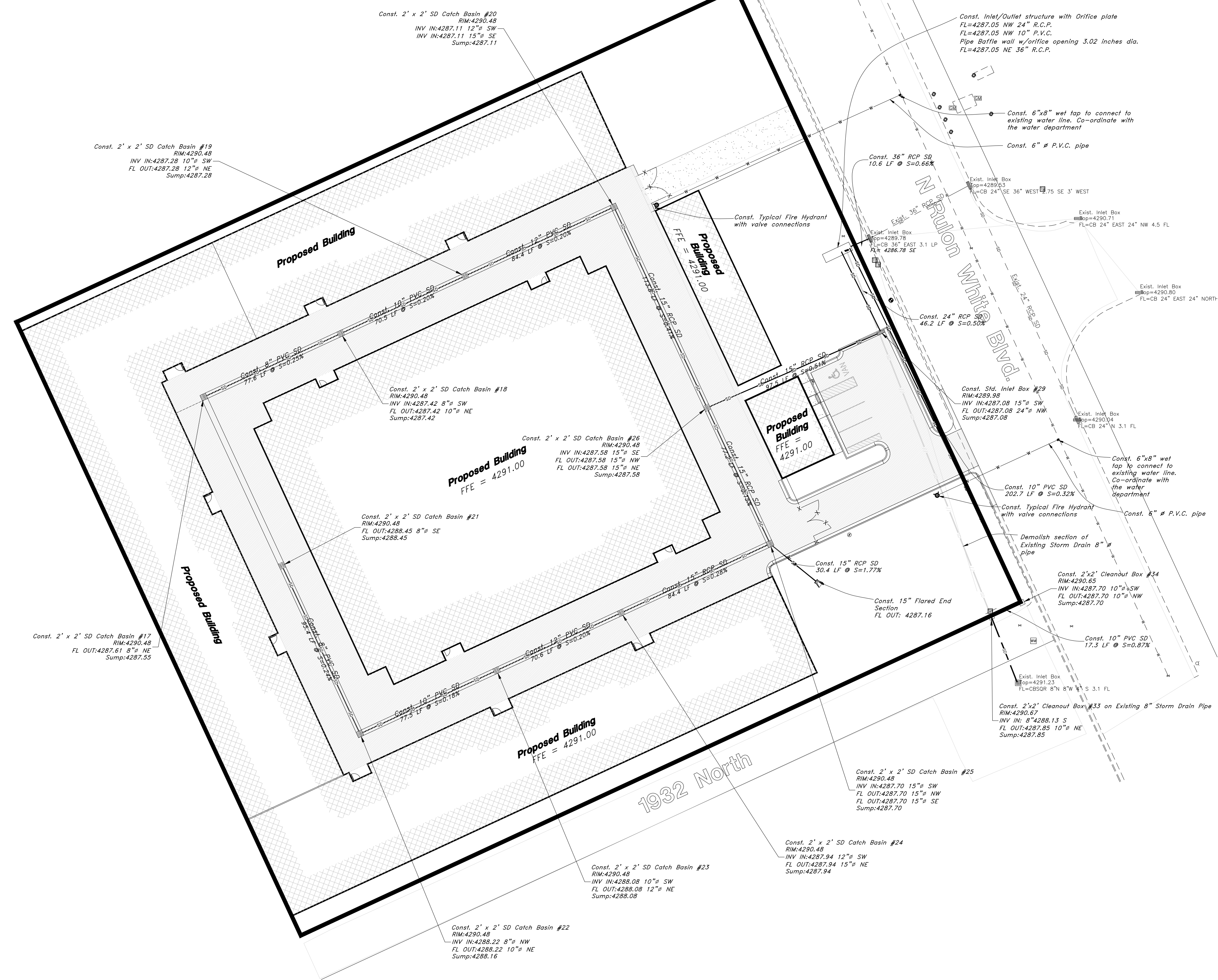

- GENERAL UTILITY NOTES:
- Coordinate all utility connections to building with plumbing plans and building contractor.
 - Verify depth and location of all existing utilities prior to constructing any new utility lines.
 - Notify Civil Engineer of any discrepancies or conflicts prior to any connections being made.
 - All catch basin and inlet box grates are to be bicycle proof.
 - All inlet boxes located in curb and gutter are to be placed parallel to the curb and gutter and set under the frame and grate. Improperly placed boxes will be removed and replaced at no additional cost to the owner. Precast or cast in place boxes are acceptable.
 - Refer to the site electrical plan for details and locations of electrical lines, transformers and light poles.
 - Gas lines, telephone lines, and cable TV lines are not a part of these plans unless otherwise noted.
 - Water meters are to be installed per city standards and specifications. It will be the contractor's responsibility to install all items required.
 - Water lines, valves, fire hydrants, fittings etc. are to be constructed as shown. Contractor is responsible to construct any vertical adjustments necessary to clear sewer, storm drain or other utilities as necessary including valve boxes and hydrant spools to proper grade.
 - Field verify all existing and/or proposed Roof Drain/Roof Drain down spout connections to Storm Water System with Civil, Plumbing & Architectural plans. Notify Engineer of any discrepancies.
 - All gravity flow utility lines shall be installed prior to any pressurized utilities unless written permission is obtained from the engineer of record before construction begins.
 - Contractor to verify existing water & sewer lateral & water meter meet Layton City Standards prior to construction.
 - Fire hydrants and access roads shall be installed prior to construction of any buildings. All hydrants shall be with the 4.5" connection facing the point of access fore Fire Department Apparatus. Provide written assurance that this will be met.
 - The private fire hydrants shall be annually maintained and a 5-year flow test shall be performed in accordance with NFPA 24 and 25. All records shall be provided and submitted through The Compliance Engine found at <http://www.thecomplianceengine.com>
 - Prior to beginning construction of any buildings, a fire flow test of the new hydrants shall be conducted to verify the actual fire flow available for this project. The Fire Prevention Division of this department shall witness this test and shall be notified a minimum of 48 hours prior to the test.
- UTILITY PIPING MATERIALS:
- All pipe to be installed per manufacturers recommendations. Refer to project specifications for more detailed information regarding materials, installation, etc.
- CULINARY SERVICE LATERALS
- 3/4" to 2" diameter pipe - copper tube ASTM B, Type K, Soft Temper or HDPE CTS-OD SDR-9 Poly.
 - Over 2" diameter pipe - Class 51 ductile iron pipe or C-900 DR-14 PVC pipe.
- WATER MAIN LINES AND FIRE LINES
- Pipe material as shown on utility plan view or to meet city standards.
- SANITARY SEWER LINES
- All sewer piping to be Polyvinyl Chloride (PVC) sewer pipe, ASTM D 3034, Type PSM, SDR 35
- STORM DRAIN LINES
- 12" pipes or smaller - Polyvinyl Chloride (PVC) sewer pipe, ASTM D3034, Type PSM, SDR 35
 - 12" or larger - Reinforced Concrete Pipe, ASTM C76, Class III up to 13' of cover, Class IV for 13' to 21' of cover, Class V for 21' to 32' of cover, and Special Design for cover greater than 32 feet.
- NATURAL GAS SERVICE LATERALS (QUESTAR)
- PLASTIC PIPING MATERIAL: Plastic polyethylene pipe materials and compression couplings must be approved for natural gas applications and must be installed underground. All plastic pipe and fittings must conform to ASTM D2513 (60 psi and above high density pipe approved 3408).
 - Plastic pipe must be joined by individuals qualified in the heat fusion method of connecting pipe and fittings or approved mechanical fittings. A minimum number 18 insulated yellow copper tracer wire shall be installed with underground nonmetallic gas piping and shall terminate above grade at each end. Tracer wire shall not come in contact with plastic piping.
 - Risers and prefabricated risers inserted with plastic pipe shall conform to ASTM D2513, shall be metallic, have a space of 10 inches from the bottom of the service valve and grade, and shall be wrapped or coated to a point at least 6 inches above grade or protected in an approved manner. When a riser connects underground to plastic pipe, the underground horizontal metallic portion of the riser shall extend at least 12 inches before connecting to the plastic pipe by means of an approved transition fitting, adapter or heat fusion.
 - Plastic pipe used underground for customer fuel lines must be approved polyethylene material and be buried a minimum of 12 inches. It shall not be used inside buildings or above ground. PVC (Polyvinyl Chloride) is not approved for piping systems in Questar Gas's service area. Individual gas lines (metallic or plastic) to single outside appliance (outside lights, grilles, etc.) shall be installed a minimum of 8 inches below grade, provided such installation is approved and installed in locations not susceptible to physical damage.

CAUTION NOTICE TO CONTRACTOR

The contractor is specifically cautioned that the location and/or elevation of existing utilities as shown on these plans are based on records of the various utility companies and, where possible, measurements taken in the field. The information is not to be relied on as being exact or complete. The contractor must call the appropriate utility company at least 48 hours before any excavation to request exact field location of utilities. It shall be the responsibility of the contractor to relocate all existing utilities which conflict with the propose improvements shown on the plans.

ALL CONSTRUCTION TO CONFORM TO WEBER COUNTY STANDARDS AND SPECIFICATIONS IN RIGHT OF WAY

PRIVATE ENGINEER'S NOTICE TO CONTRACTORS

The Contractor agrees that he shall assume sole and complete responsibility for job site conditions during the course of construction of this project, including safety of all persons and property; that this requirement shall apply continuously and not be limited to normal working hours; and that the contractor shall defend, indemnify, and hold the owner and the engineer harmless from any and all liability, real or alleged, in connection with the performance of work on this project, excepting for liability arising from the sole negligence of the owner or the engineer.

For Review
03/07/2022 12:50:23 PM

GREAT BASIN ENGINEERING

5746 SOUTH 1475 EAST OGDEN, UTAH 84403
MAIN (801)594-4515 S.L.C (801)521-0222 FAX (801)392-7544
WWW.GREATBASINENGINEERING.COM

Utility Plan

Weber Storage Sheds
1957 N. Rulon White Blvd.
Ogden City, Weber County, Utah
A part of Section 22, T2N, R2W, S1E&M, U.S. Survey

Jan, 2022

SHEET NO. **C3**

21N713

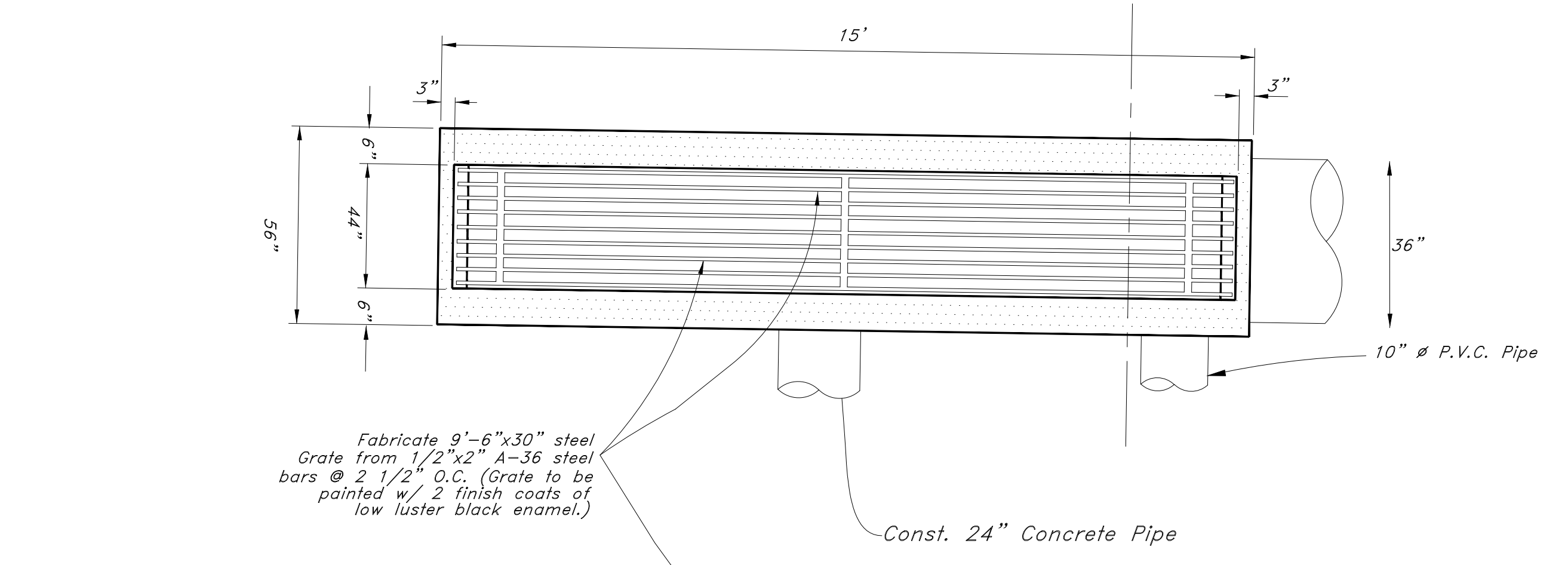

Note: Inlet/Outlet Structure is to be Cast in Place.

Note: Reinforce Walls and Floor with #4 bars @ 12" O.C. (Both Directions).

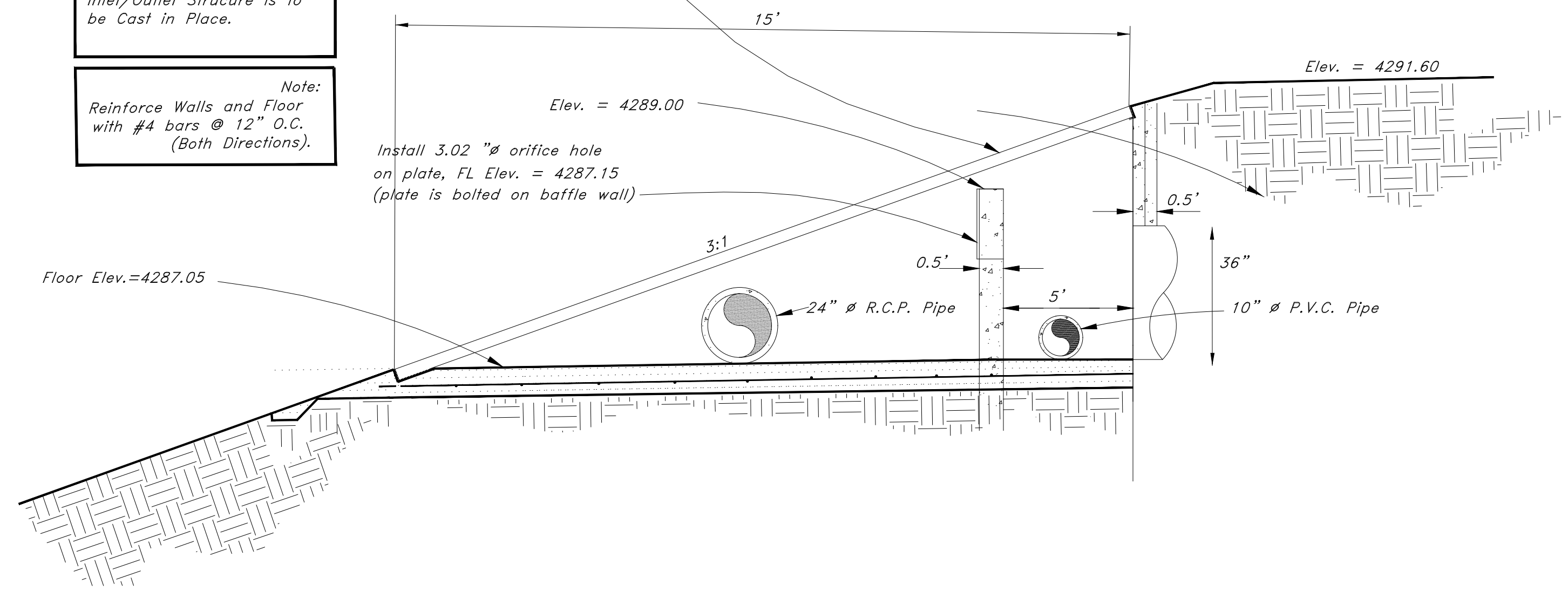

Detail of Inlet / Outlet Structure

Not to Scale

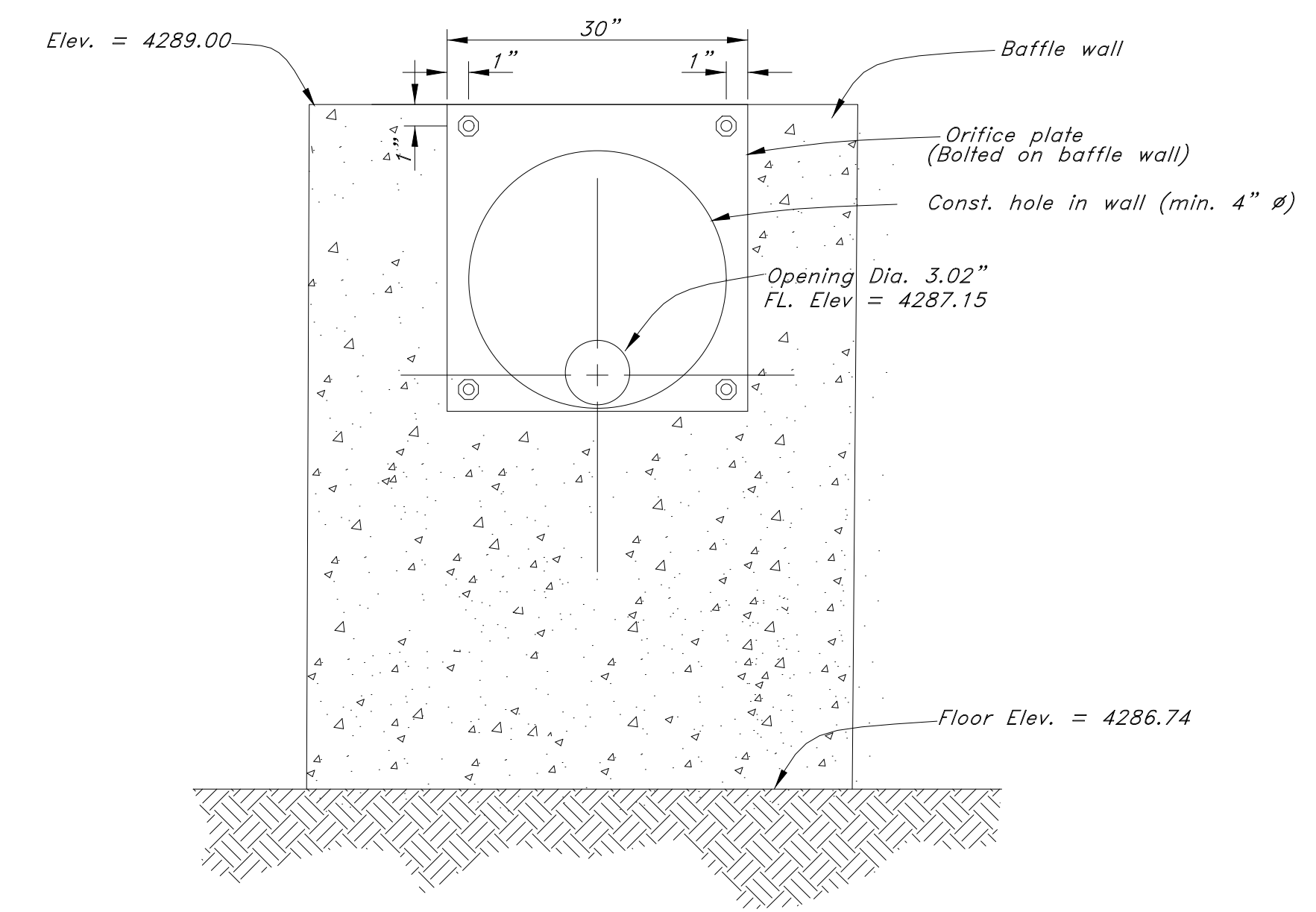
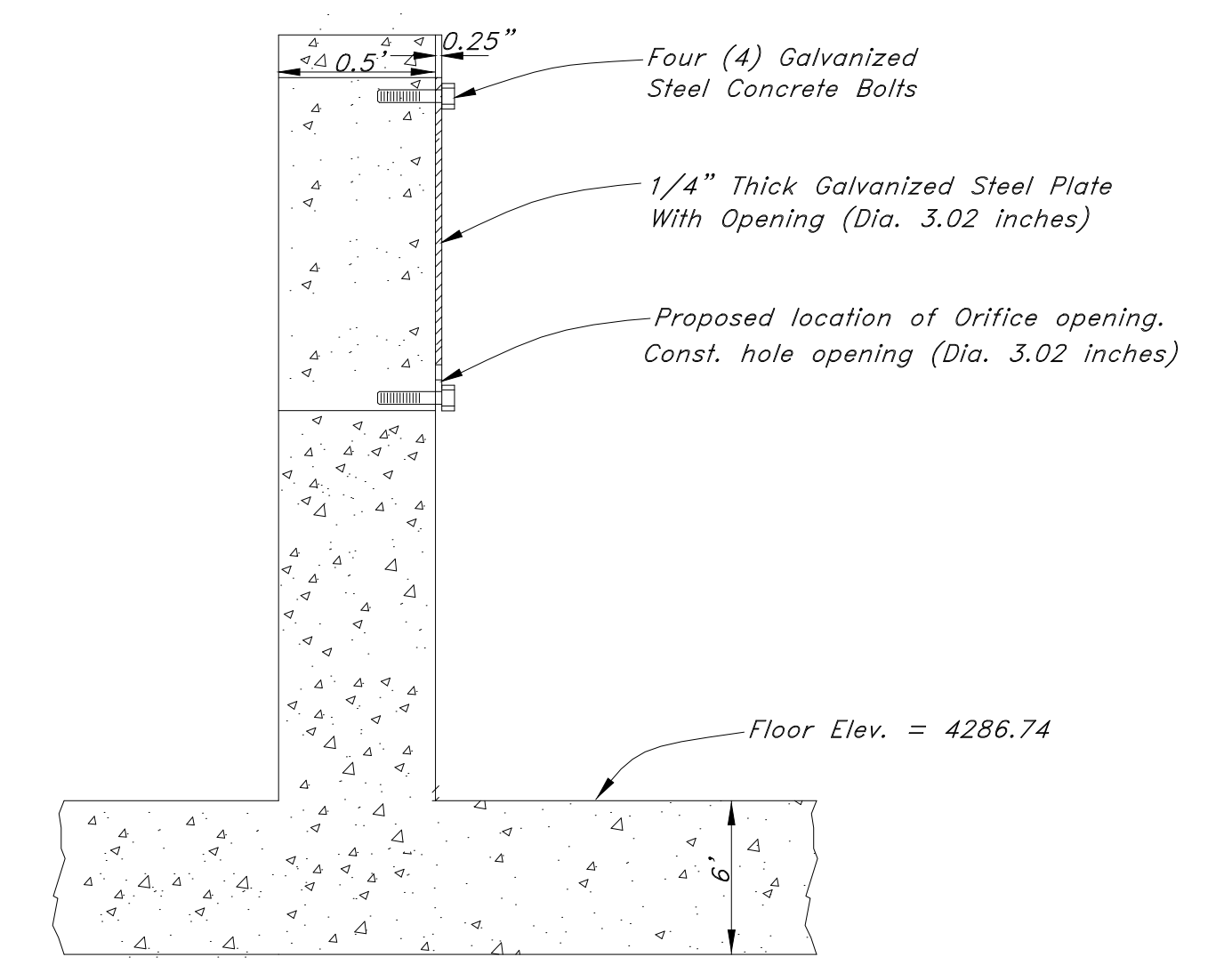

Orifice Plate Detail

Not to Scale

For Review

03/07/2022 12:50:26 PM

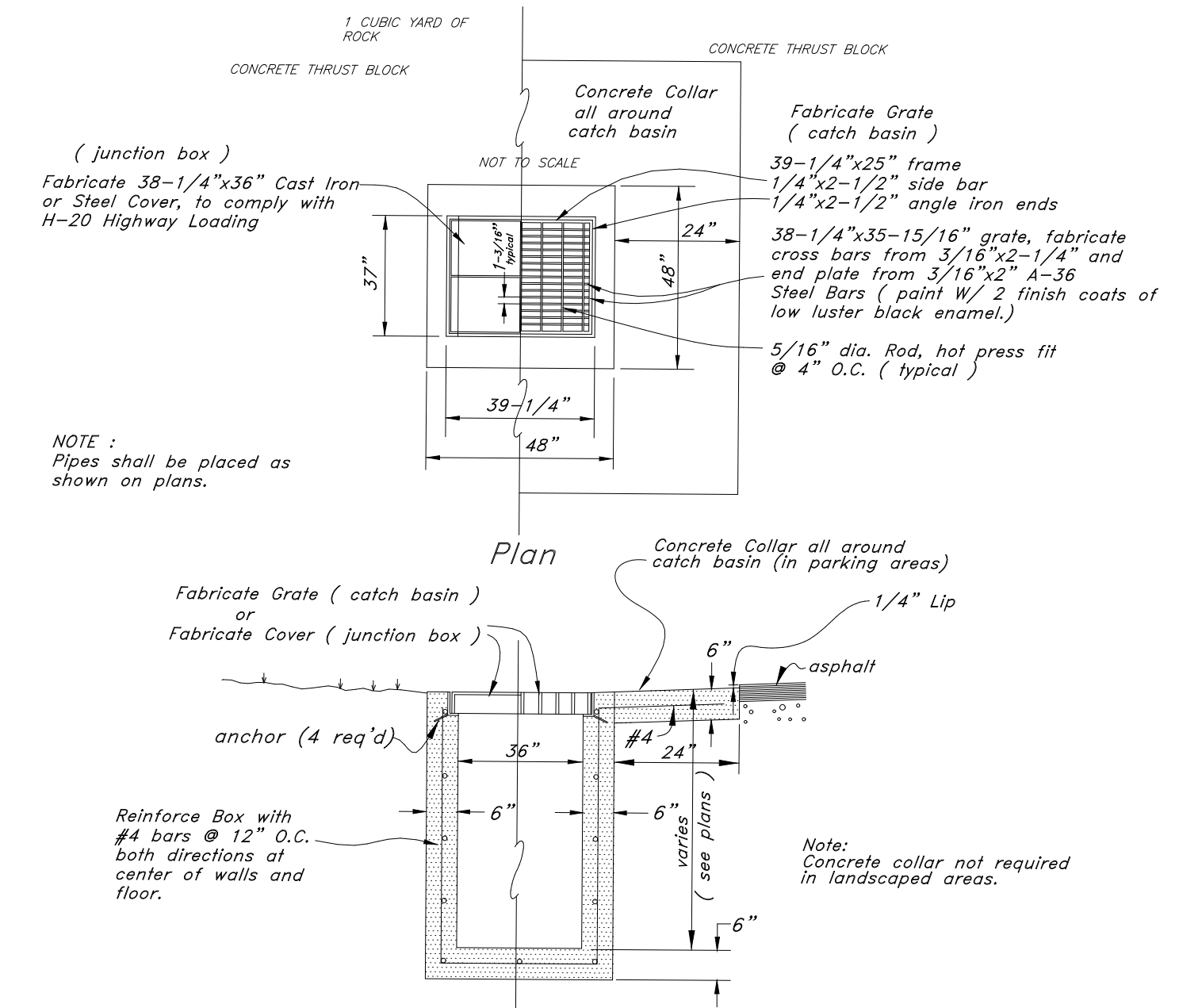

TYPICAL 4' x 4' CATCH BASIN JUNCTION BOX

NOT TO SCALE

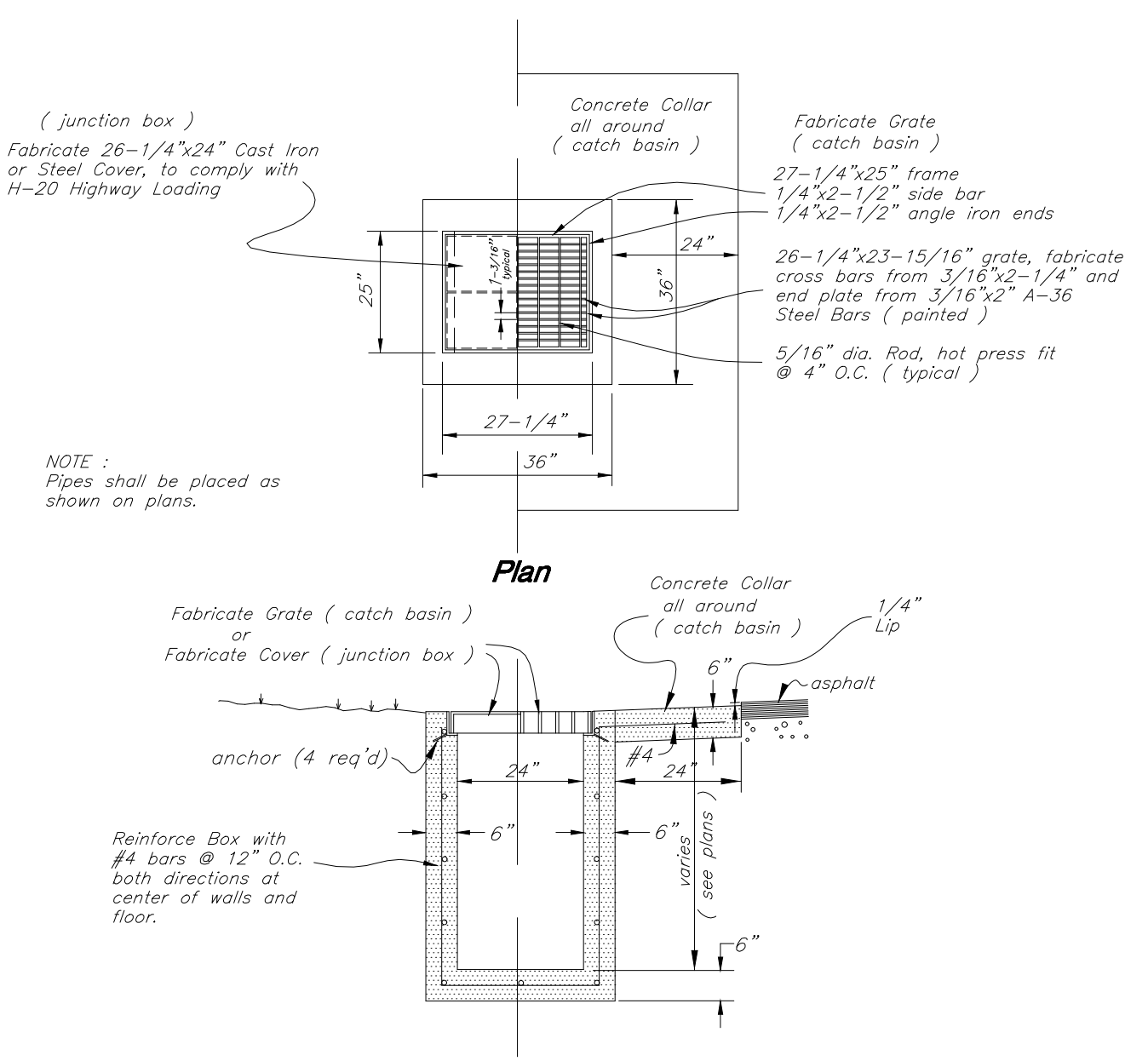

TYPICAL 2' x 2' CATCH BASIN JUNCTION BOX

NOT TO SCALE

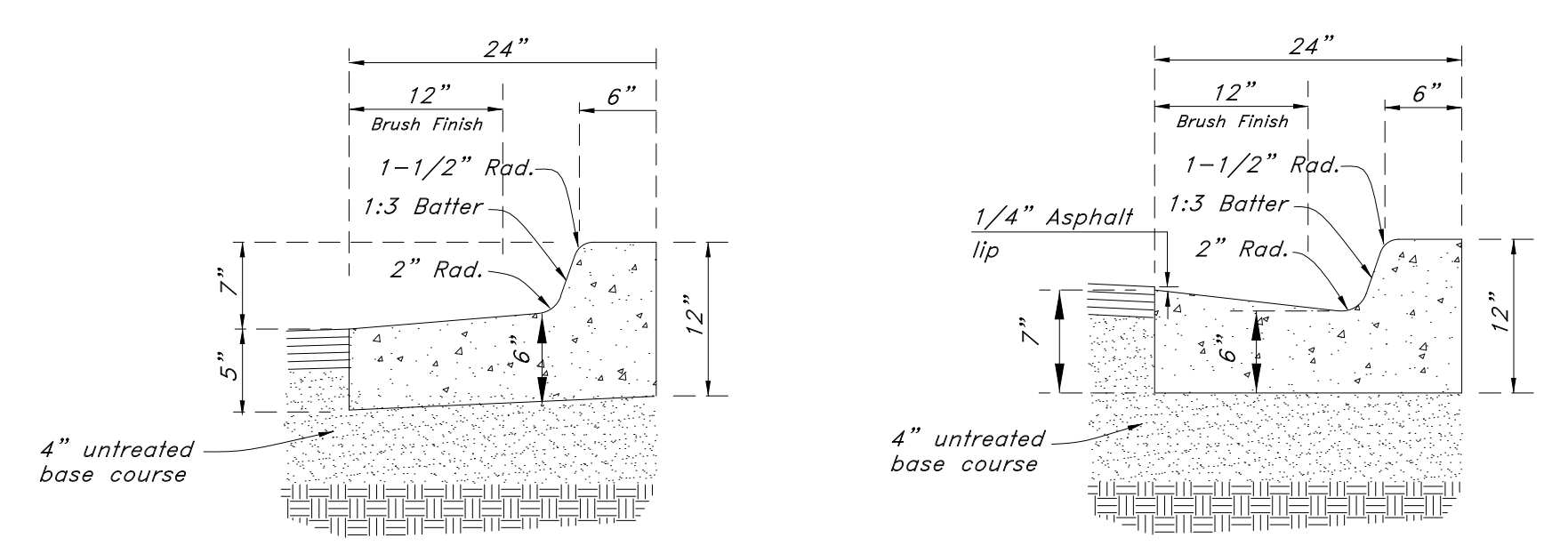

Typical Section - 24" Curb & Gutter

Not to Scale

GREAT BASIN ENGINEERING

5746 SOUTH 1475 EAST OGDEN, UTAH 84403
 MAIN (801)994-4515 S.L.C (801)521-0222 FAX (801)392-7544
 WWW.GREATBASINENGINEERING.COM

Details Sheets

Weber Storage Sheds

1957 N. Rulon White Blvd
 Ogden City, Weber County, Utah

A part of Section ??, TPN, RPW, SL&M, U.S. Survey

Jan, 2022

SHEET NO.

C4.1

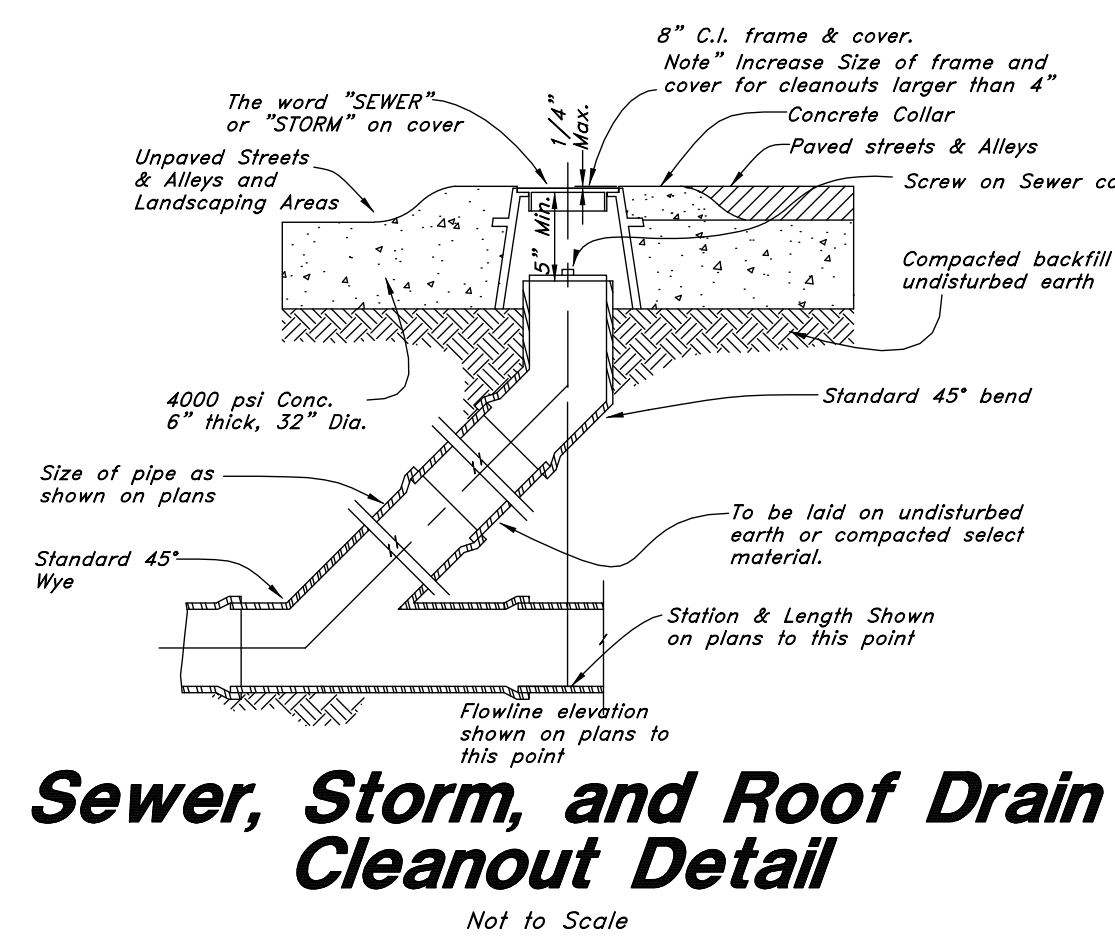

Sewer, Storm, and Roof Drain Cleanout Detail
Not to Scale

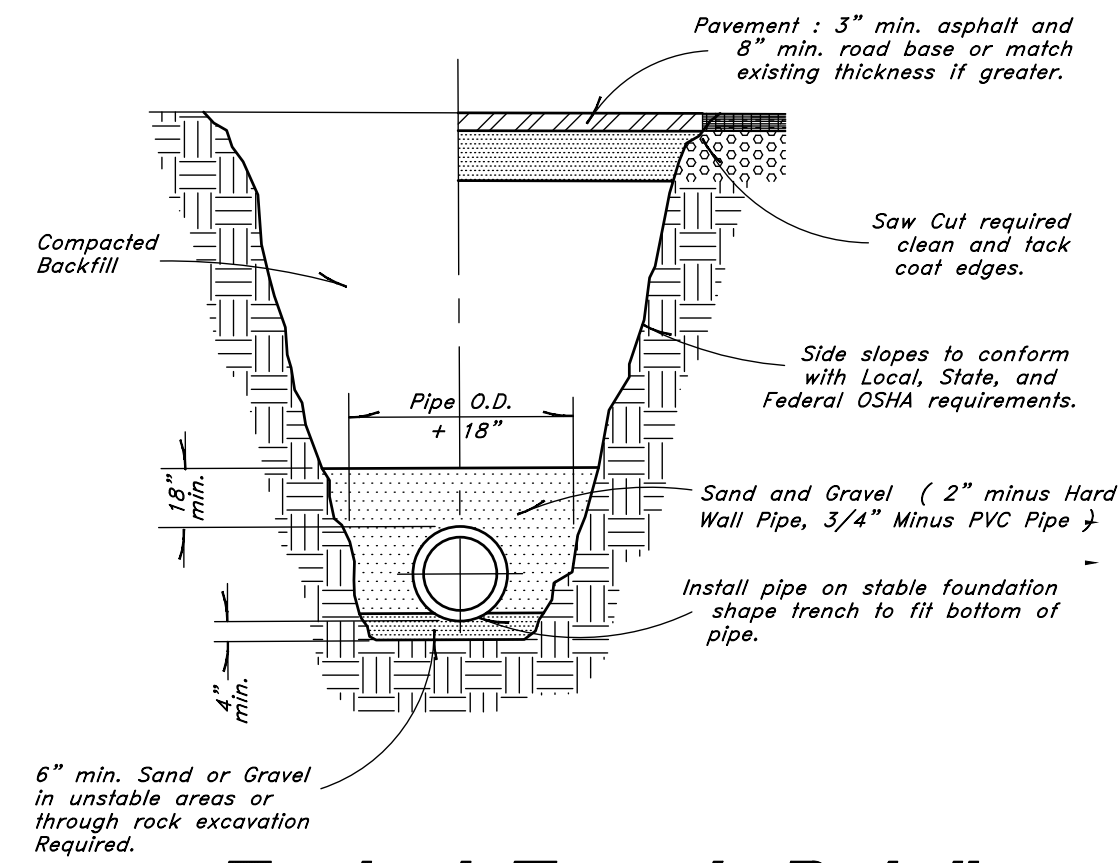

Typical Trench Detail
Not to Scale

Typical Bituminous Pavement Section
Not to Scale

Typical Waterway Detail
Not to Scale

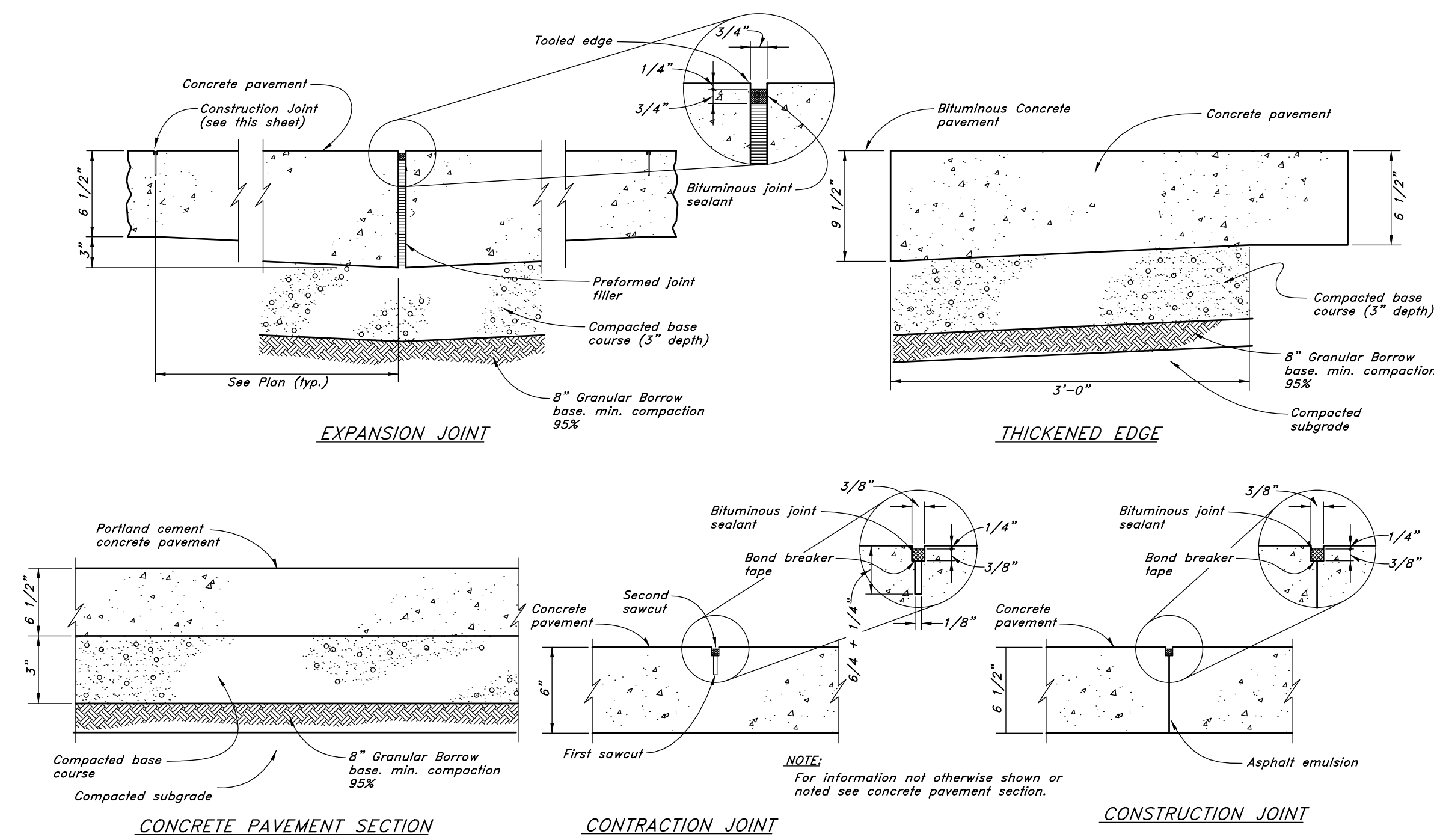
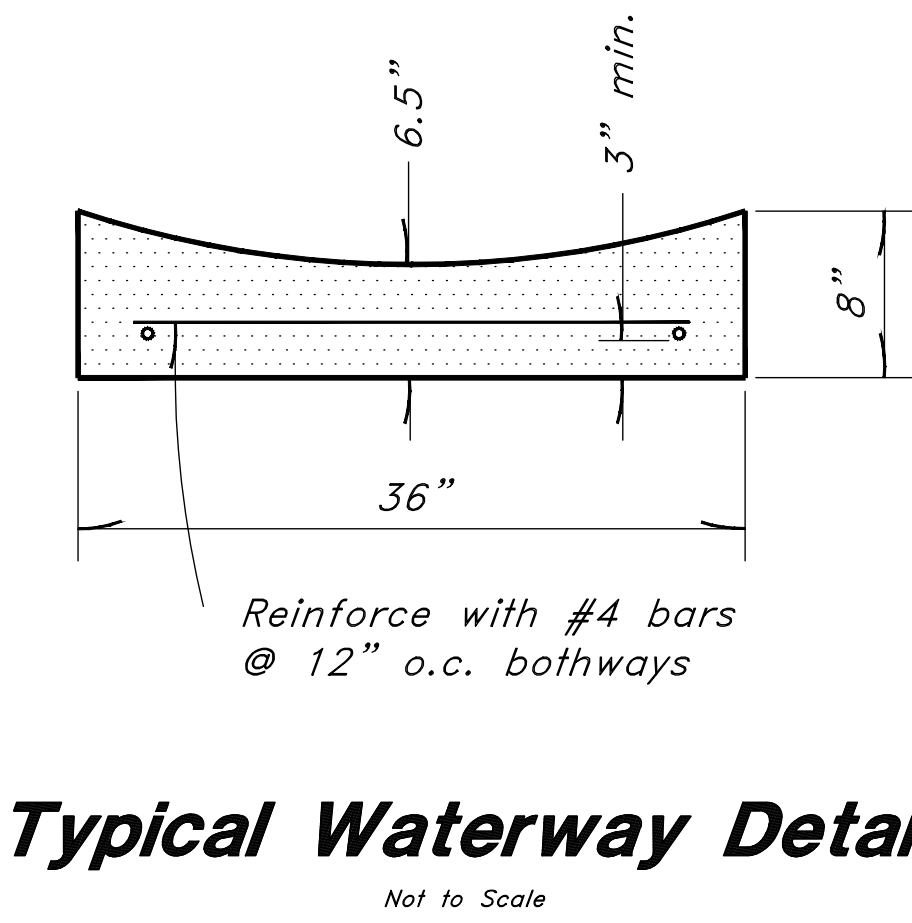
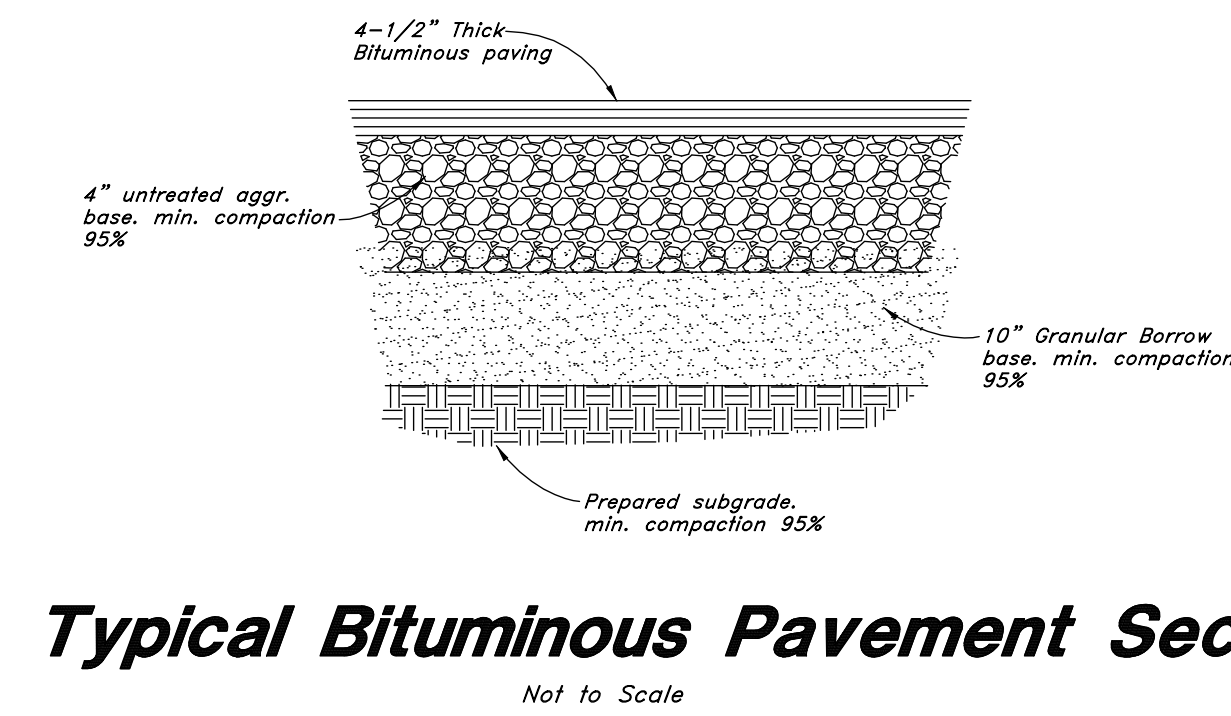

Portland Cement Concrete Pavement
Not to Scale

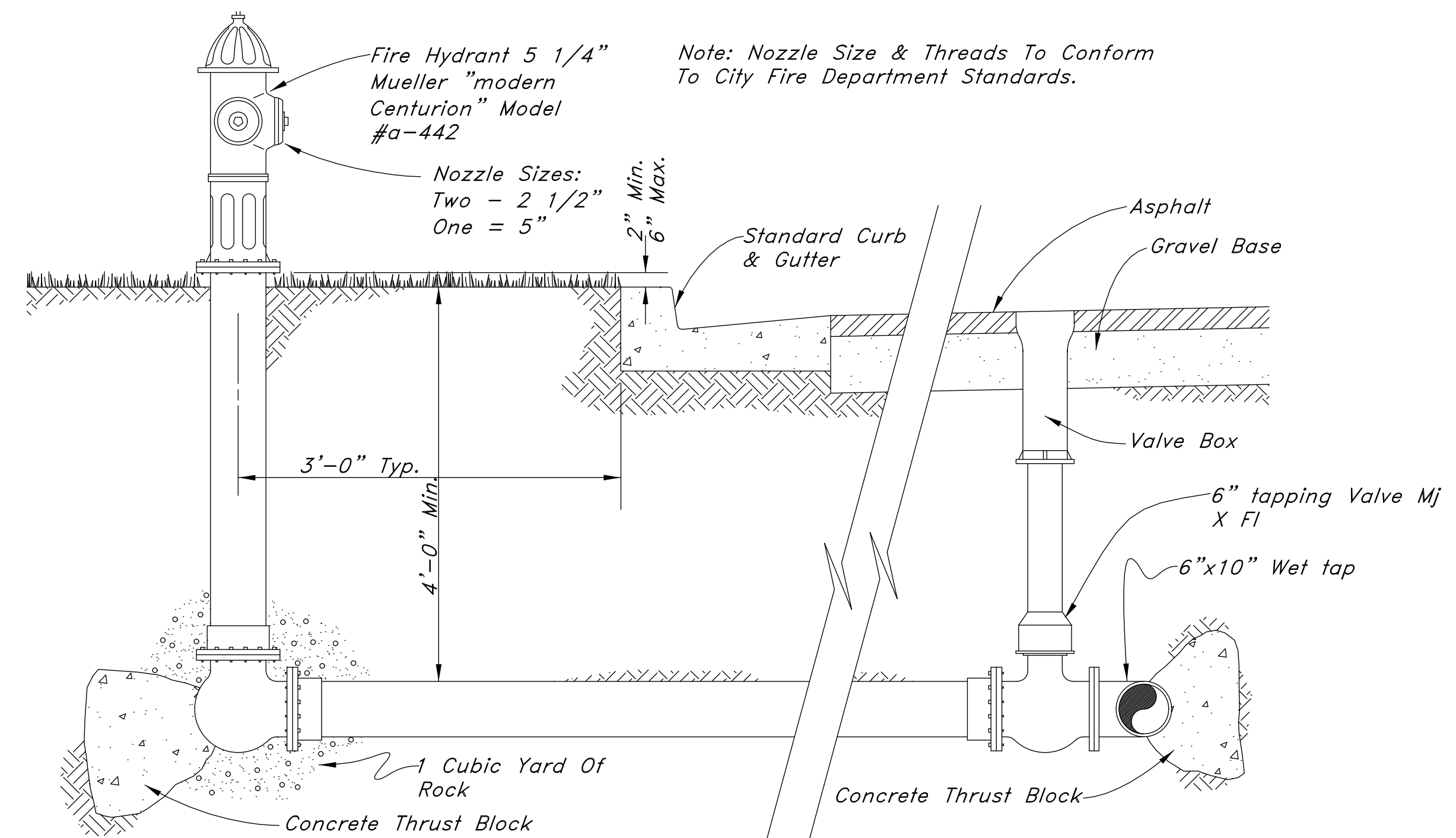

Typical Fire Hydrant & Valve Connection
Not to Scale

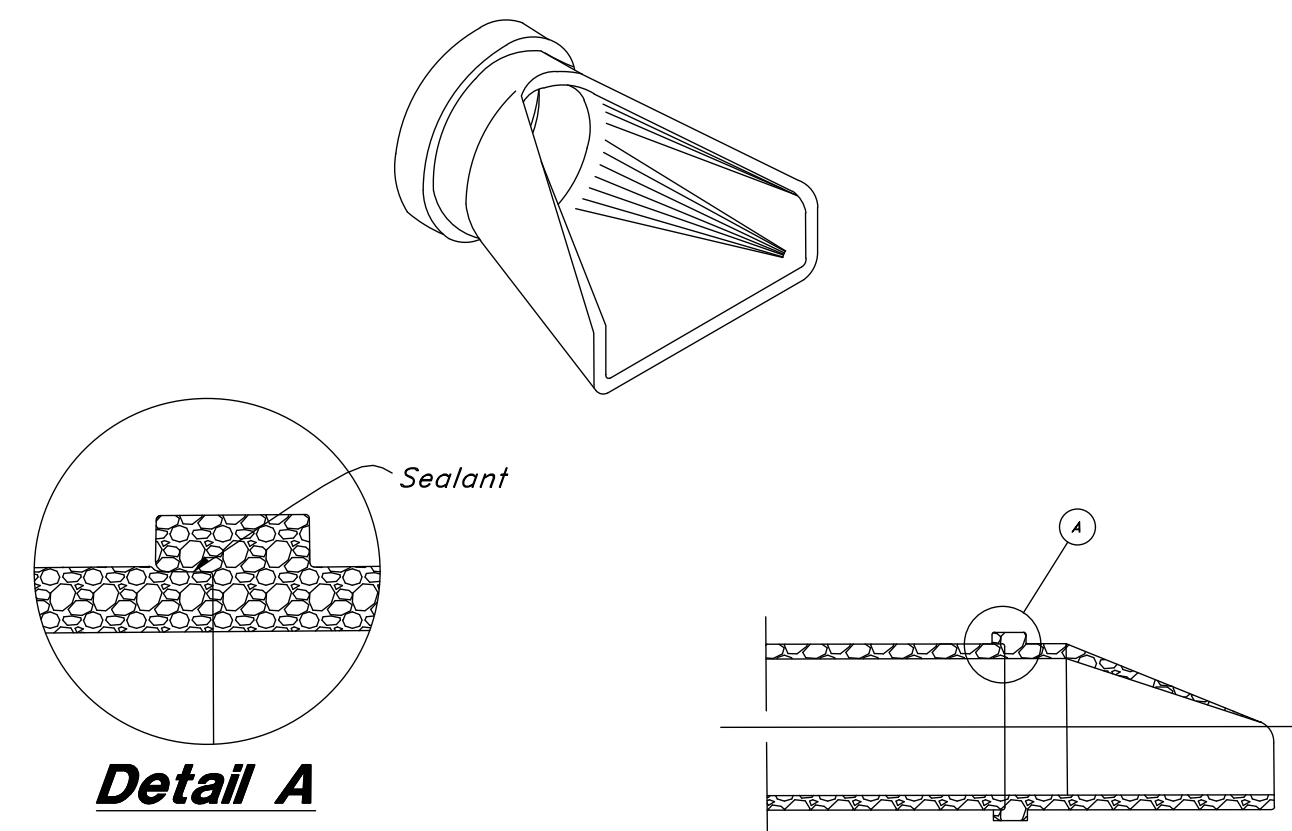

Detail A
Sealant Detail Check CP110 and CP120
For Specific Joint Details

Flared End Section
Not to Scale

For Review
03/07/2022 12:50:29 PM

GREAT BASIN ENGINEERING
5746 SOUTH 1475 EAST OGDEN, UTAH 84403
MAIN (801)394-4515 SLLC (801)521-0222 FAX (801)392-7544
WWW.GREATBASINENGINEERING.COM

Webster Storage Sheds
1957 N. Rulon White Blvd.
Ogden City, Weber County, Utah
A part of Section ??, TPN, RPW, SLB&M, U.S. Survey

Jan, 2022

SHEET NO.

C4.2

21N713