

STAGECOACH ESTATES IMPROVEMENT DRAWINGS

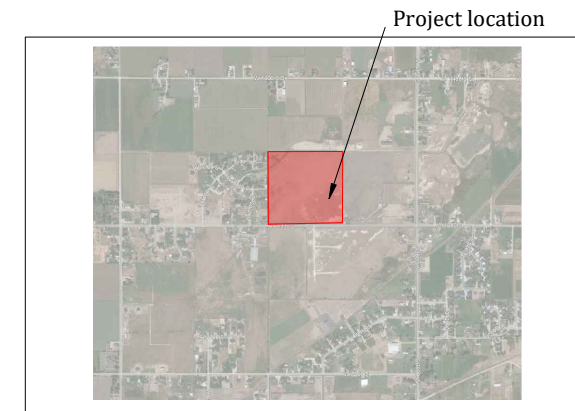

VICINITY MAP

No Scale

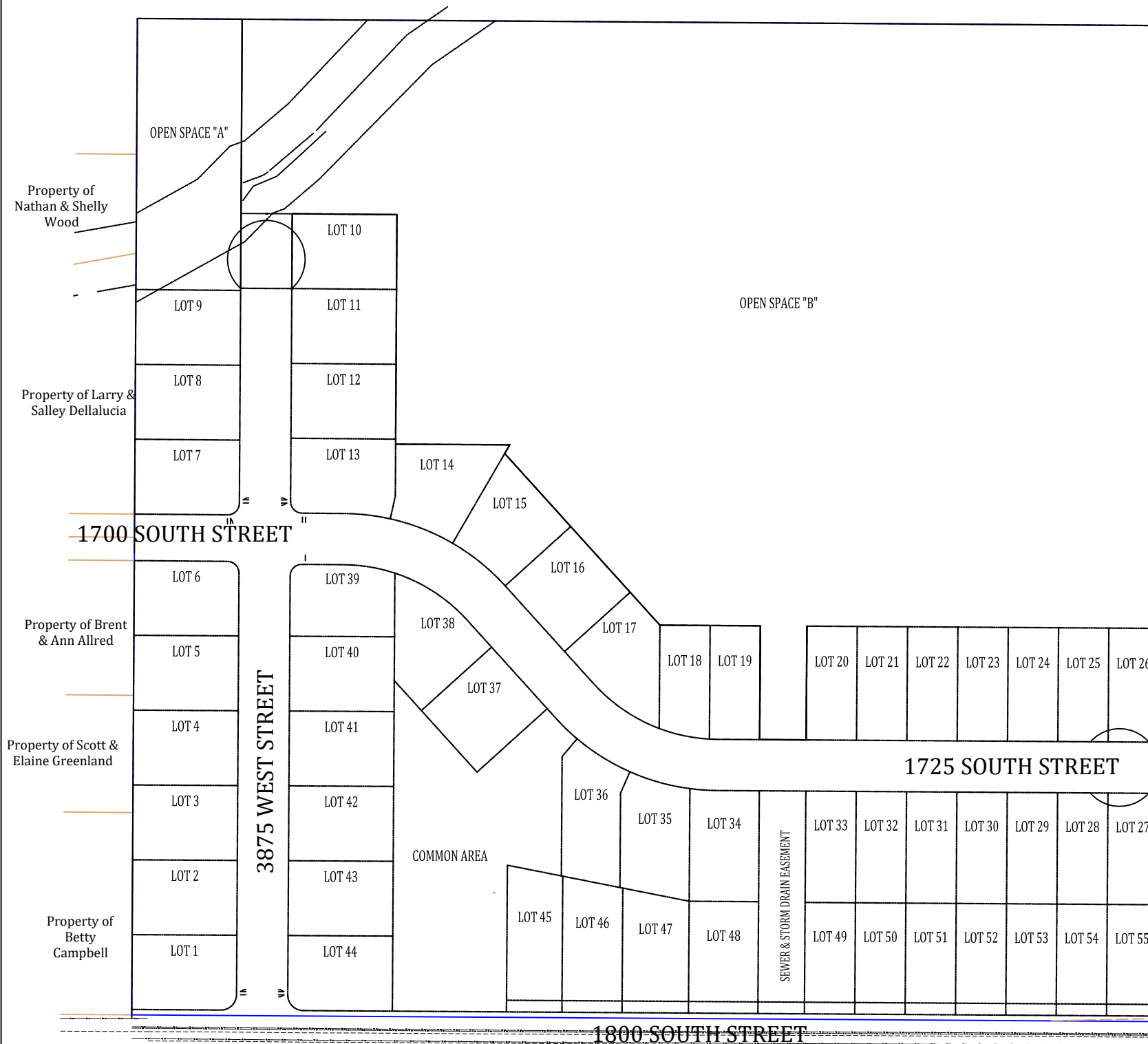

Winston Park Subdivision

SHEET INDEX	
1 of 37	COVER SHEET
2 of 37	NOTES
3 of 37	SITE PLAN
4 of 37	SANITARY SEWER IMPROVEMENTS
5 of 37	STORM DRAIN IMPROVEMENTS
6 of 37	LAND DRAIN IMPROVEMENTS
7 of 37	CULINARY WATER IMPROVEMENTS
8 of 37	SECONDARY WATER IMPROVEMENTS
9 of 37	GRADING PLAN
10 of 37	3875 WEST STREET PLAN & PROFILE: STA 0+00 - 3+50
11 of 37	3875 WEST STREET PLAN & PROFILE: STA 3+50 - 7+50
12 of 37	3875 WEST STREET PLAN & PROFILE: STA 7+50 - 11+25
13 of 37	DETENTION POND #1 PLAN & PROFILE: STA 500+00 - 502+00
14 of 37	1700/1725 SOUTH STREET PLAN & PROFILE: STA 100+00 - 103+50
15 of 37	1725 SOUTH STREET PLAN & PROFILE: STA 103+50 - 107+00
16 of 37	1725 SOUTH STREET PLAN & PROFILE: STA 107+00 - 110+50
17 of 37	1725 SOUTH STREET PLAN & PROFILE: STA 110+50 - 114+23
18 of 37	DETENTION POND #2 PLAN & PROFILE: STA 200+00 - 204+26
19 of 37	DETENTION POND #3 PLAN & PROFILE: STA 400+00 - 403+75
20 of 37	1800 SOUTH STREET PLAN & PROFILE: STA 300+00 - 303+50
21 of 37	1800 SOUTH STREET PLAN & PROFILE: STA 303+50 - 307+00
22 of 37	1800 SOUTH STREET PLAN & PROFILE: STA 307+00 - 310+50
23 of 37	1800 SOUTH STREET PLAN & PROFILE: STA 310+50 - 314+00
24 of 37	DETAILS: ROADS
25 of 37	DETAILS: ROADS
26 of 37	DETAILS: ROAD
27 of 37	DETAILS: TRENCHING
28 of 37	DETAILS: CULINARY WATER
29 of 37	DETAILS: CULINARY WATER
30 of 37	DETAILS: CULINARY WATER & STORM DRAIN
31 of 37	DETAILS: STORM DRAIN
32 of 37	DETAILS: DETENTION POND #1 INLET/OUTLET STRUCTURE
33 of 37	DETAILS: DETENTION POND #2 INLET/OUTLET STRUCTURE
34 of 37	DETAILS: STORM DRAIN VAULT
35 of 37	DETAILS: STORM DRAIN VAULT
36 of 37	DETAILS: STORM DRAIN VAULT
37 of 37	DETAILS: STORM DRAIN VAULT

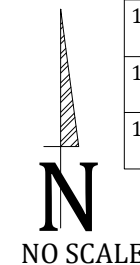

Developer:
Pat Burns
Lync Construction
801-710-2234

Approved for Construction

Weber County Engineer
Date: _____

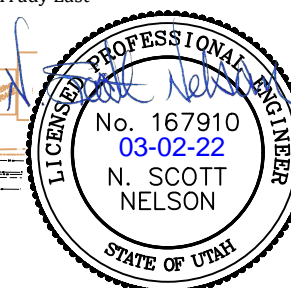

Project: **IMPROVEMENTS
STAGECOACH ESTATES
WEBER COUNTY, UTAH**

Title: **COVER SHEET**

Date: 2 MARCH 2022

Sheet 1 of 37

Prepared By:
Summers Engineering Collective
- Jen Summers -
Summers.eng.collective@gmail.com

#	Date:	Revision:

ABBREVIATIONS USED IN DRAWINGS

adj	adjust	dwg	drawing	hp	high point	pr	proposed	tbc	top back of curb
arv	air release valve	elec	electrical	in	inch	prc	point of reverse curve	tele	telephone
bw	back of walk	eg	existing grade	inv	invert	prv	pressure reducing valve	toa	top of asphalt
bvce	beginning vertical curve elev.	elev	elevation	irr	irrigation	pt	point of tangency	toe	toe of slope
bvcs	beginning vertical curve station	eoc	edge of concrete	lf	linear foot	pue	public utility easement	top	top of slope
bw	both ways	ep	edge of pavement	lip	lip of curb	pvc	polyvinyl chloride pipe	tow	top of wall
cb	catch basin	evce	end vertical curve elev.	lt	left	r	radius	tow	top of walk
chord	chord bearing	evcs	end vertical curve station	max	maximum	rc	rebar & cap	typ	typical
cl	centerline	ew	each way	mh	manhole	row	right of way	w	water
cmp	corrugated metal pipe	exist	existing	min	minimum	rt	right	wm	water meter
co	clean out	ff	finished floor elevation	mon	monument	sd	storm drain	wmh	water manhole
conc	concrete	fg	finished grade	nts	not to scale	sec cor	section corner	wv	water valve
conc	concrete	fh	fire hydrant	oc	on center	ser	south end radius		
cw	culinary water	fl	flow line	ohp	over head power	ss	sanitary sewer		
da	delta angle	fo	fiber optic	pc	point of curvature	ssmh	sanitary sewer manhole		
det	detail	ft	foot	pi	point of intersection	sta	station		
dia	diameter	gb	grade break	pl	property line	std	standard		
dip	ductile iron pipe	hdpe	high density poly ethylene	pp	power pole	sw	secondary water		

GENERAL CONSTRUCTION NOTES

- The utilities shown on the drawings are for informational purposes only. The contractor shall locate all underground utilities, contact blue stakes and other applicable utilities prior to laying pipe within 200 feet of said utilities which may be exposed, damaged or crossed as shown on the drawings or as "blue staked". The contractor shall coordinate with the utility company to move the utility if necessary. The contractor shall not modify grade of project lines in order to go over and around existing utilities. The contractor shall pothole for the location of utilities prior to excavation.
- The contractor shall review and verify all dimensions shown on the drawings.
- The contractor shall be responsible to provide appropriate signing and barricading. All flagging, signage and barricades and all traffic control required shall be in compliance with the current "manual on uniform traffic control devices".
- All public and private roadways must be cleaned daily, or as often as required, of all loose dirt, mud, gravel and all debris as a result of the construction work. This requirement shall apply continuously throughout the duration of the project and shall not be limited to normal construction working hours.

- All dust on project site shall be controlled by sweeping and watering the construction area.
- The contractor shall be completely responsible for the job site conditions during the course of construction, including safety of all persons and adjoining property. This requirement shall apply continuously throughout the duration of the project and not be limited to normal construction working hours.
- Verify depth and location of all existing utilities prior to constructing any new utility lines. Notify project engineer of any discrepancies or conflicts prior to any connections being made.
- The contractor shall be responsible for meeting all of the requirements established for safe trenching. (See OSHA and UOSHA requirements, latest editions).
- Specific information provided in the contract documents shall supersede items covered in these drawings.
- The contractor shall contact and coordinate all utility connections with the utility owner.
- All construction to comply with specifications contained herein and with local City, County and State standards and specifications.

LEGEND AND SYMBOLS

Centerline of road	Culinary water manhole & pipe	Fire hydrant
Contour line	Fiber optic box & line	Storm drain catch basin
Curb & gutter	Gas manhole & line	Street sign
Easement line	Irrigation manhole and pipe	Street light
Fence	Land drain manhole & pipe	Water meter
Lot line	Power pole and line	Water valve
Phase/boundary line	Sanitary sewer manhole & pipe	*Note: All existing features will be in a shaded line
Right of way line	Storm drain manhole & pipe	
Section corner & line	Telephone pedestal & line	

UTILITY CONTACTS

TAYLOR WEST WEBER WATER IMPROVEMENT DISTRICT
 2815 WEST 3300 SOUTH
 WEST HAVEN, UT 84401
 (801) 731-1668
 RYAN ROGERS, GENERAL MANAGER

WEBER COUNTY FIRE DISTRICT
 2023 WEST 1300 NORTH
 FARR WEST, UT 84404
 (801) 782-3580
 BRANDON J. THUESON, FIRE MARSHAL

HOOPER IRRIGATION COMPANY
 5375 SOUTH 5500 WEST
 HOOPER, UT 84315
 (801) 388-3956
 DENNIS FLINDERS, SECONDARY WATER MANAGER

UTAH DIVISION OF ENVIRONMENTAL QUALITY
 195 NORTH 1950 WEST
 SALT LAKE CITY, UT 84116
 (801) 536-4123

CENTRAL WEBER SEWER DISTRICT
 2618 WEST PIONEER ROAD
 OGDEN, UT 84404
 (801) 731-3011

UTAH DIVISION OF DRINKING WATER
 195 NORTH 1950 WEST
 SALT LAKE CITY, UT 84116
 (801) 536-4400

WEBER COUNTY ENGINEERING DEPARTMENT
 2380 WASHINGTON BLVD
 SUITE 240
 OGDEN, UT 84401
 (801) 399-8374

ROCKY MOUNTAIN POWER
 1438 WEST 2550 SOUTH
 OGDEN, UT 84401
 (866) 221-7070

CAUTION NOTICE TO CONTRACTOR

The contractor is herewith instructed that the location and/or elevation of existing utilities as shown on these plans are based on records of the various utility companies and, where possible, measurements taken in the field. The information shown is not to be relied on as being exact or complete. The contractor is required to call the appropriate utility company as least 48 hours before any excavation to request exact field location of utilities. Is the sole responsibility of the contractor to relocate all existing utilities which conflict with the proposed improvements shown on the drawings.

The contractor shall assume sole and complete responsibility for job site conditions during the course of construction of this project, including safety of all persons and property. This requirement shall apply continuously and not be limited to the normal working hours; and the contractor shall defend, indemnify, and hold the owner and the engineer harmless from any and all liability, real or alleged, in connection with the performance of work on this project, excepting for liability arising from sole negligence of the owner or the engineer.

CALL BEFORE YOU DIG.

IT'S FREE & IT'S THE LAW.

(TOLL FREE) **1-800-662-4111**

BLUE STAKES OF UTAH
 UTILITY NOTIFICATION CENTER, INC.
www.bluestakes.org

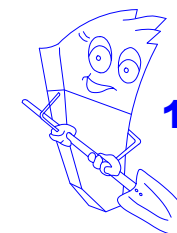

Developer:
 Pat Burns
 Lync Construction
 801-710-2234

Approved for Construction

 Weber County Engineer
 Date: _____

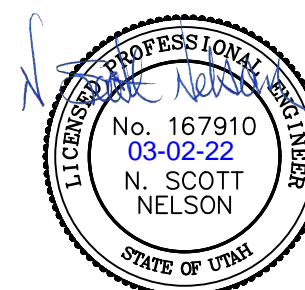

Project: **IMPROVEMENTS STAGECOACH ESTATES WEBER COUNTY, UTAH**

Prepared By:
Summers Engineering Collective
 - Jen Summers -
 Summers.eng.collective@gmail.com

Title: **NOTES**
 Date: 2 MARCH 2022 | Sheet 2 of 37

#	Date:	Revision:

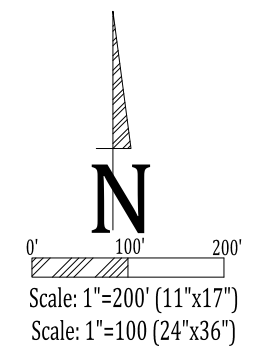
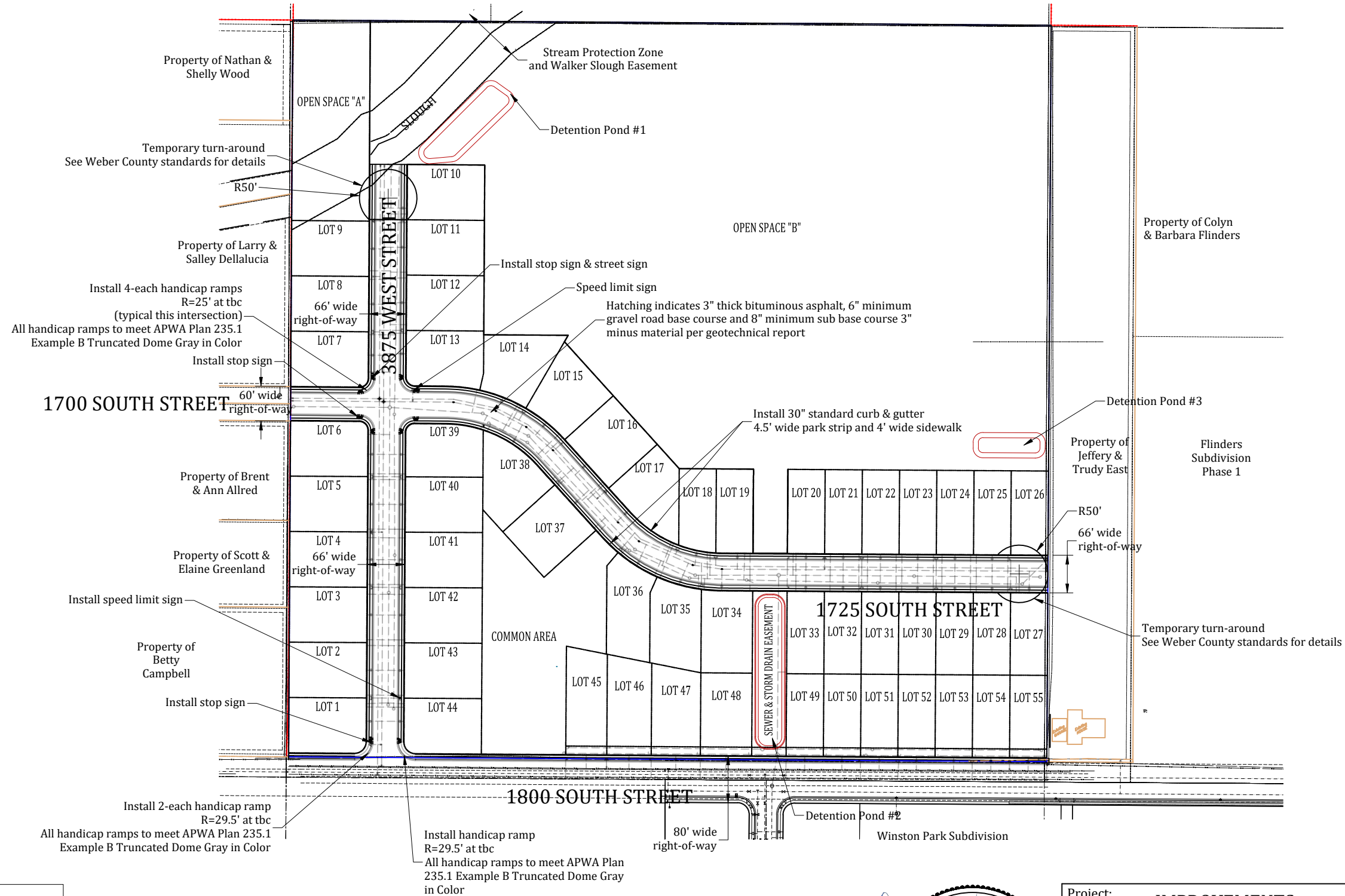

Developer:
Pat Burns
Lync Construction
801-710-2234

Approved for Construction
Weber County Engineer
Date: _____

The Geotechnical Report provided by: CMT Engineering Laboratories (Project No. 10878, Dated March 7, 2018) has critical information in regards to this project and must be followed.

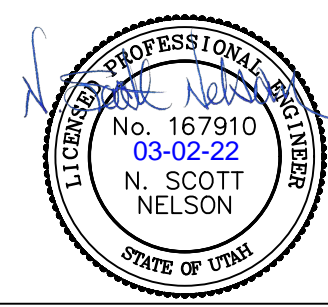

Project: IMPROVEMENTS STAGECOACH ESTATES WEBER COUNTY, UTAH
Title: SITE PLAN
Date: 2 MARCH 2022 | Sheet 3 of 37

Prepared By: Summers Engineering Collective - Jen Summers - Summers.eng.collective@gmail.com

#	Date	Revision

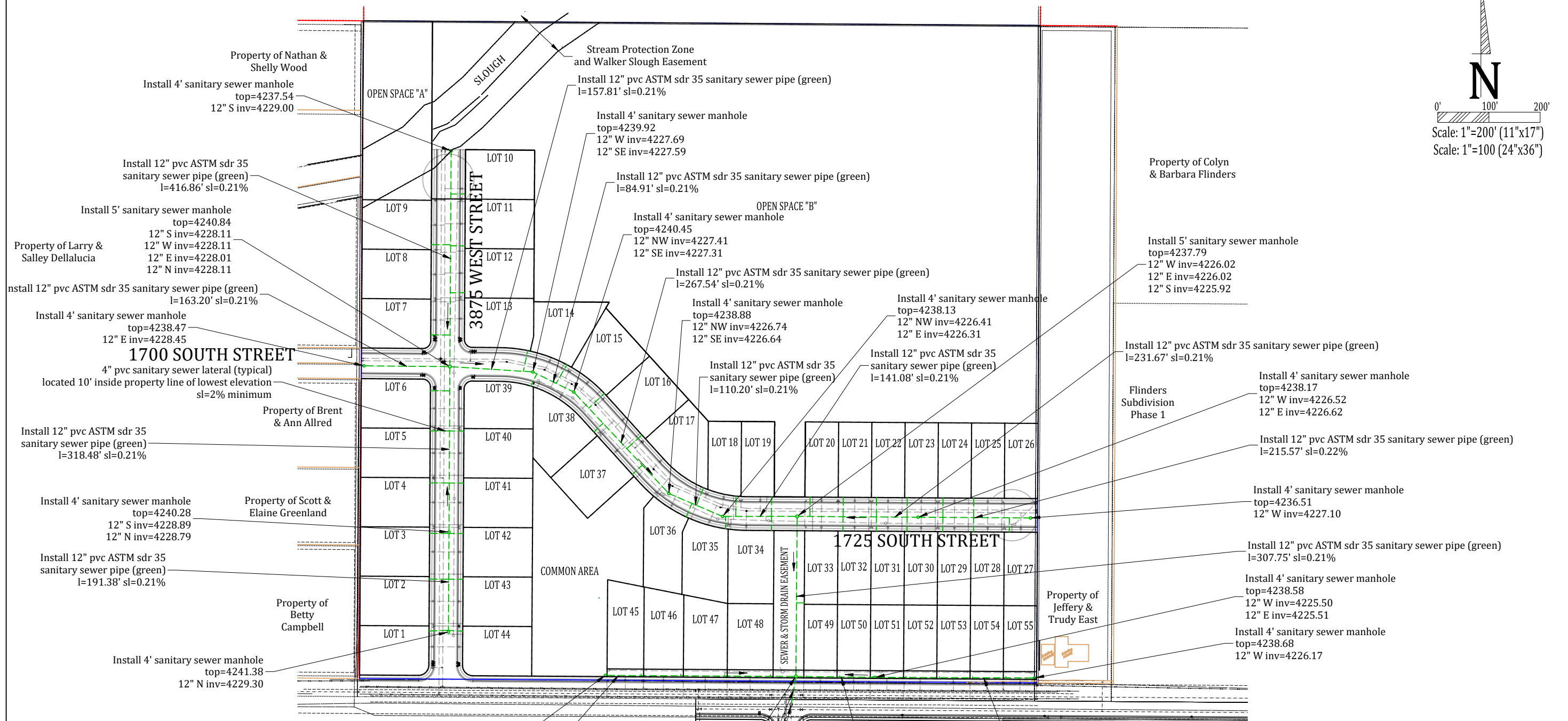
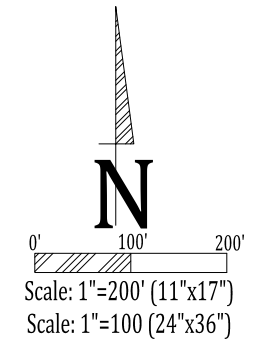

Developer:
Pat Burns
Lync Construction
801-710-2234

Approved for Construction
Weber County Engineer
Date: _____

The Geotechnical Report provided by: CMT Engineering Laboratories (Project No. 10878, Dated March 7, 2018) has critical information in regards to this project and must be followed.

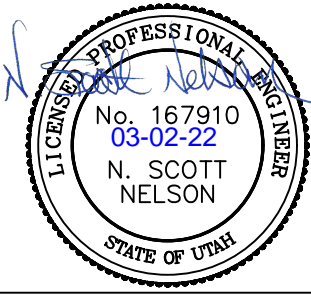

Project: **IMPROVEMENTS STAGECOACH ESTATES WEBER COUNTY, UTAH**

Title: **SANITARY SEWER IMPROVEMENTS**

Date: 2 MARCH 2022

Sheet 4 of 37

Prepared By: **Summers Engineering Collective**
- Jen Summers -
Summers.eng.collective@gmail.com

#	Date:	Revision:

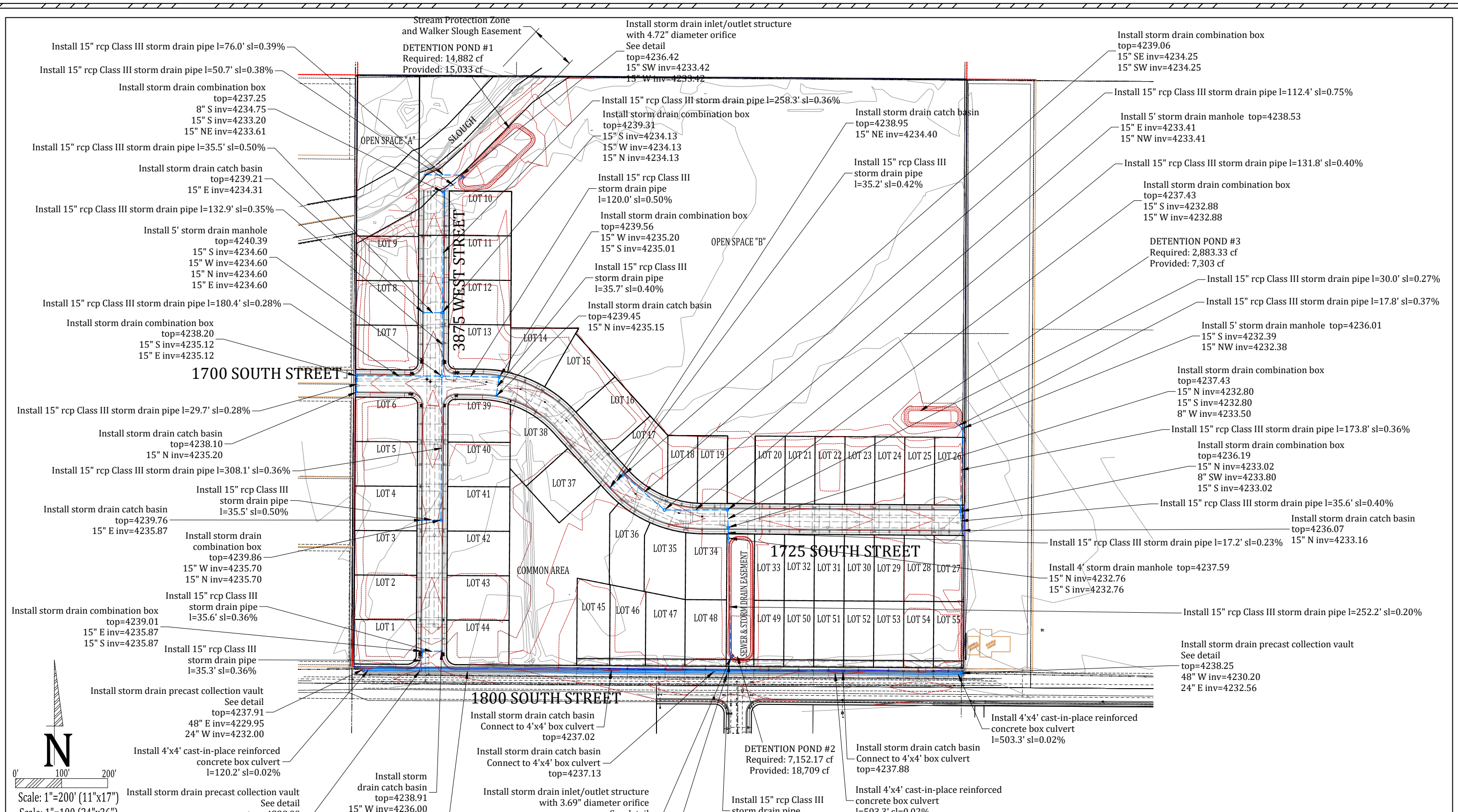

Developer:
 Pat Burns
 Lync Construction
 801-710-2234

Approved for Construction
 Weber County Engineer
 Date: _____

The Geotechnical Report provided by: CMT Engineering Laboratories (Project No. 10878, Dated March 7, 2018) has critical information in regards to this project and must be followed.

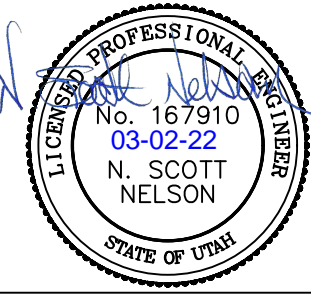

Project: **IMPROVEMENTS STAGECOACH ESTATES WEBER COUNTY, UTAH**

Title: **STORM DRAIN IMPROVEMENTS**

Date: 2 MARCH 2022

Sheet 5 of 37

Prepared By: **Summers Engineering Collective**
 - Jen Summers -
 Summers.eng.collective@gmail.com

#	Date:	Revision:

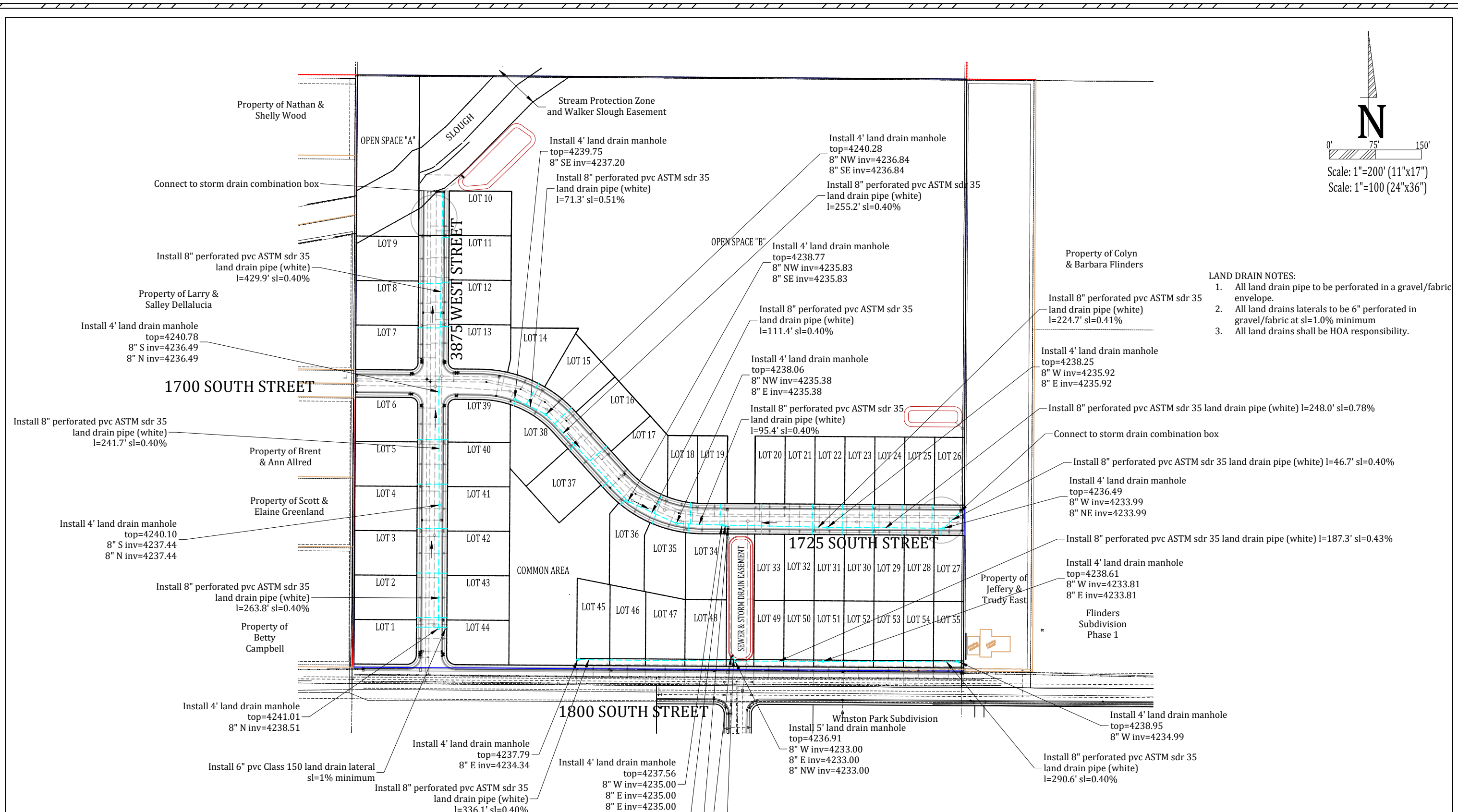
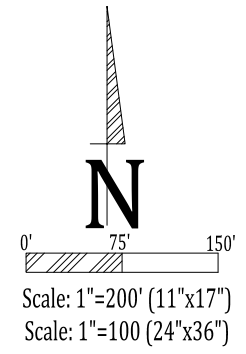

- LAND DRAIN NOTES:**
1. All land drain pipe to be perforated in a gravel/fabric envelope.
 2. All land drains laterals to be 6" perforated in gravel/fabric at sl=1.0% minimum
 3. All land drains shall be HOA responsibility.

Developer:
 Pat Burns
 Lync Construction
 801-710-2234

Approved for Construction

Weber County Engineer
 Date: _____

The Geotechnical Report provided by: CMT Engineering Laboratories (Project No. 10878, Dated March 7, 2018) has critical information in regards to this project and must be followed.

Install 8" perforated pvc ASTM sdr 35 land drain pipe (white) l=10.1' sl=14.82%

Connect to storm drain combination box

Connect to storm drain inlet/outlet box

Install 8" perforated pvc ASTM sdr 35 land drain pipe (white) l=7.6' sl=11.59%

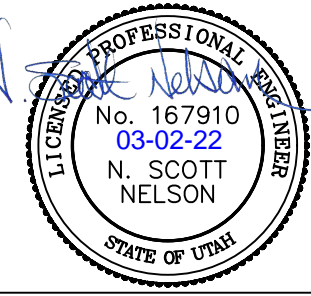

Project: **IMPROVEMENTS STAGECOACH ESTATES WEBER COUNTY, UTAH**

Title: **LAND DRAIN IMPROVEMENTS**

Date: 2 MARCH 2022

Sheet 6 of 37

Prepared By: **Summers Engineering Collective**
 - Jen Summers -
 Summers.eng.collective@gmail.com

#	Date:	Revision:

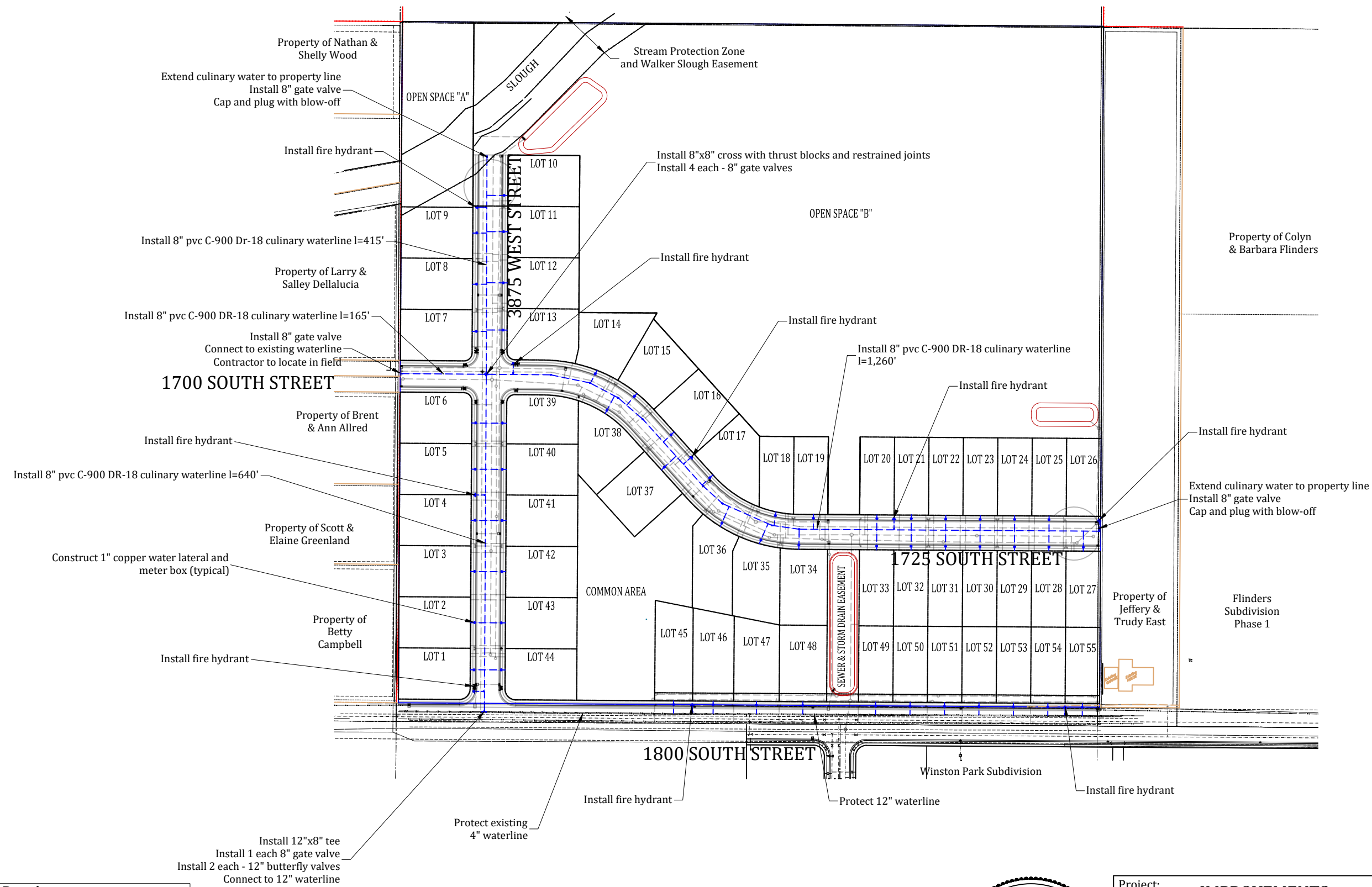
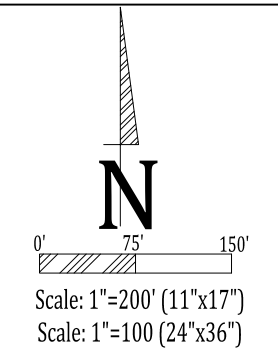

- CULINARY WATER NOTES:**
1. Contractor to loop waterlines as required
 2. All fire hydrants shall meet Water District Standards.

Developer:
Pat Burns
Lync Construction
801-710-2234

Approved for Construction
Weber County Engineer
Date: _____

The Geotechnical Report provided by: CMT Engineering Laboratories (Project No. 10878, Dated March 7, 2018) has critical information in regards to this project and must be followed.

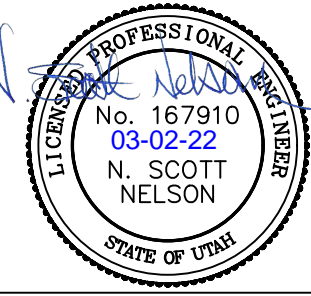

Project: **IMPROVEMENTS STAGECOACH ESTATES WEBER COUNTY, UTAH**

Title: **CULINARY WATER IMPROVEMENTS**

Date: 2 MARCH 2022

Sheet 7 of 37

Prepared By: **Summers Engineering Collective**
- Jen Summers -
Summers.eng.collective@gmail.com

#	Date:	Revision:

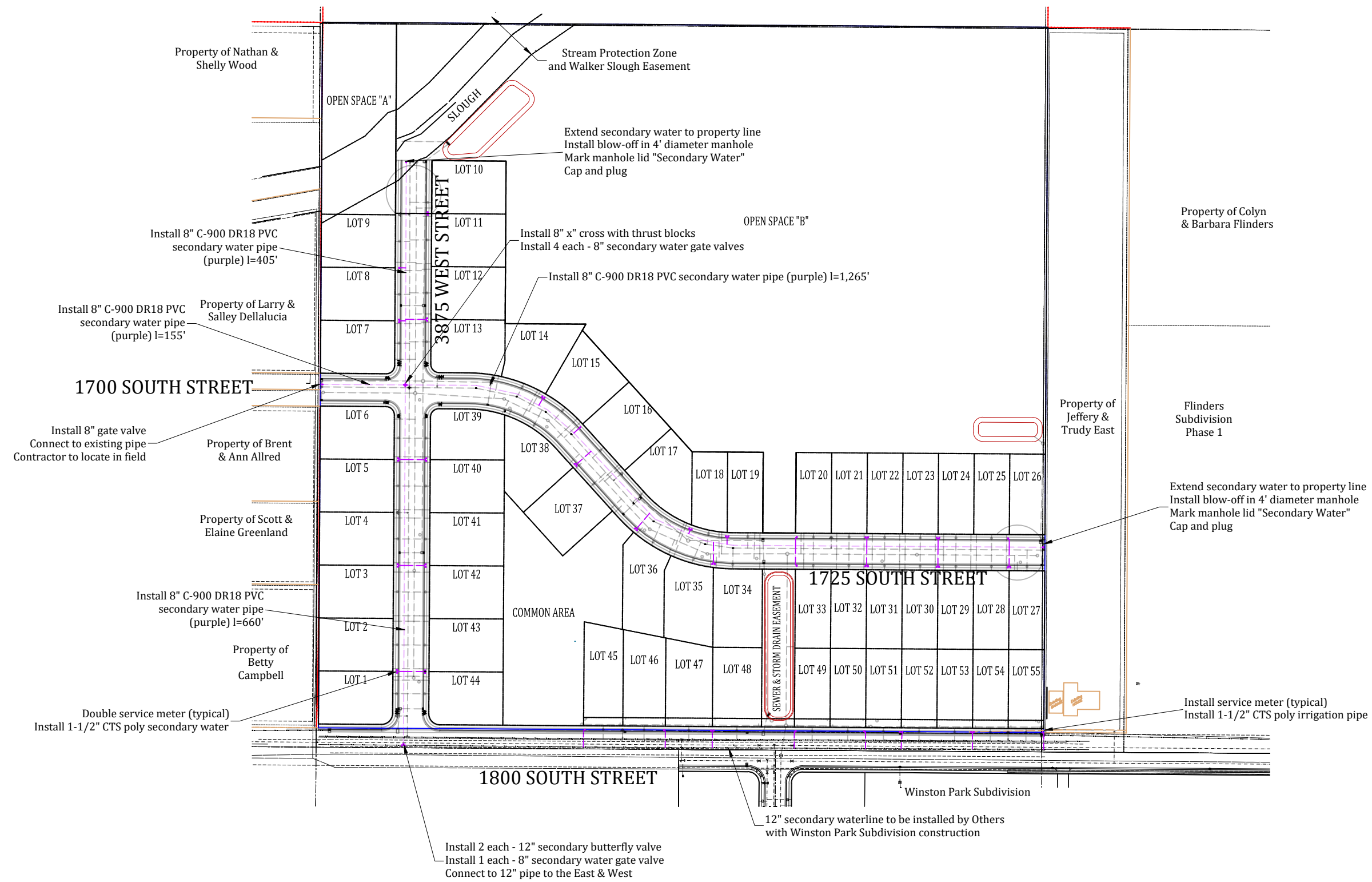
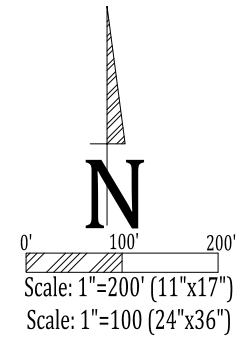

Developer:
Pat Burns
Lync Construction
801-710-2234

Approved for Construction
Weber County Engineer
Date: _____

The Geotechnical Report provided by: CMT Engineering Laboratories (Project No. 10878, Dated March 7, 2018) has critical information in regards to this project and must be followed.

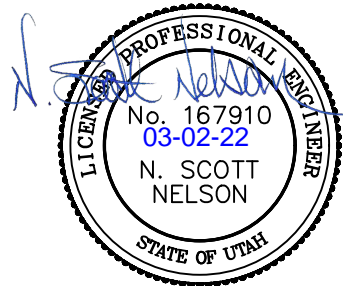

Project: IMPROVEMENTS
STAGECOACH ESTATES
WEBER COUNTY, UTAH

Title: SECONDARY WATER
IMPROVEMENTS

Date: 2 MARCH 2022

Sheet 8 of 37

Prepared By:
Summers Engineering Collective
- Jen Summers -
Summers.eng.collective@gmail.com

#	Date:	Revision:

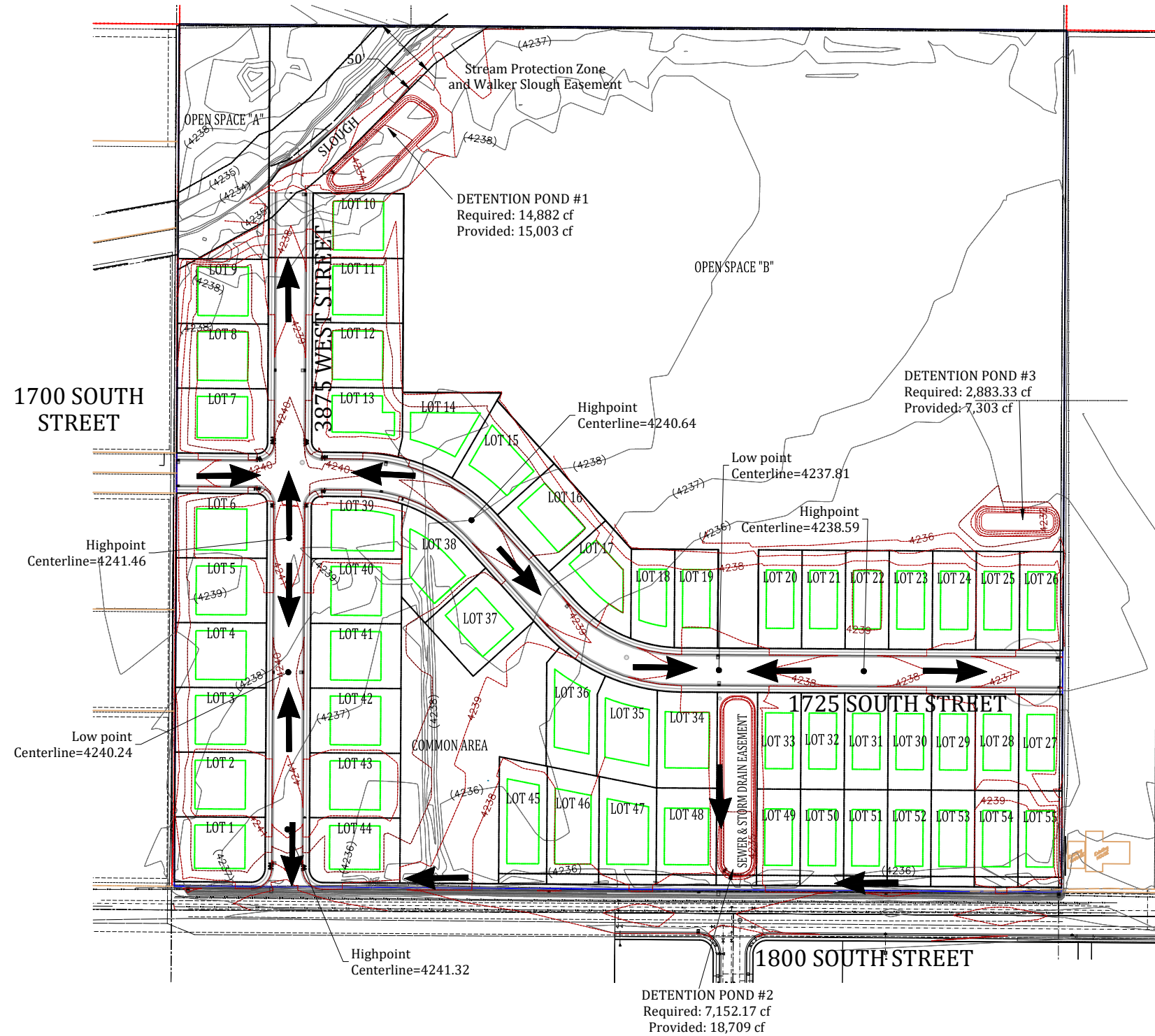

LOT INFORMATION		
LOT #	FINISH FLOOR ELEV	BUILDABLE AREA
1	4240.25	4843 sf
2	4241.5	5435 sf
3	4240.75	5435 sf
4	4240.5	5435 sf
5	4240.75	5435 sf
6	4241.25	4582 sf
7	4241.25	5440 sf
8	4241	5440 sf
9	4240.25	5437 sf
10	4238	5437 sf
11	4240.25	5437 sf
12	4241	5438 sf
13	4241.25	4711 sf
14	4240.5	4640 sf
15	4240.25	4877 sf
16	4240	4870 sf
17	4239	4547 sf
18	4238.25	3315 sf
19	4238	3536 sf
20	4238.5	3548 sf
21	4238.5	3546 sf
22	4239	3546 sf
23	4238.5	3546 sf
24	4238.5	3546 sf
25	4237.5	3546 sf
26	4237.5	3545 sf
27	4237.25	3412 sf
28	4237.5	3417 sf
29	4238.5	3414 sf
30	4238.5	3412 sf
31	4238.75	3409 sf
32	4238.25	3407 sf
33	4238.25	3404 sf
34	4238	5446 sf
35	4238	5551 sf
36	4238.5	5378 sf
37	4239.25	5146 sf
38	4240.25	5063 sf
39	4241.75	5480 sf
40	4240.75	5440 sf
41	4240.5	5440 sf
42	4240.75	5440 sf
43	4241.5	5436 sf
44	4240.25	4863 sf
45	4237.75	5378 sf
46	4238	5783 sf
47	4238.25	5750 sf
48	4238.25	5663 sf
49	4238.25	3438 sf
50	4238.25	3436 sf
51	4238.75	3433 sf
52	4238.5	3430 sf
53	4238.5	3427 sf
54	4239.5	3425 sf
55	4239.25	3415 sf

The Geotechnical Report provided by: CMT Engineering Laboratories (Project No. 10878, Dated March 7, 2018) has critical information in regards to this project and must be followed.

Developer:
Pat Burns
Lync Construction
801-710-2234

Approved for Construction
Weber County Engineer
Date: _____

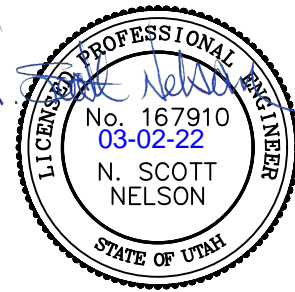
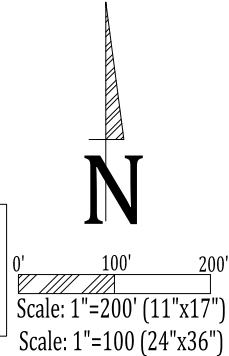

Project: **IMPROVEMENTS STAGECOACH ESTATES WEBER COUNTY, UTAH**

Title: **GRADING PLAN**

Date: 2 MARCH 2022

Sheet 9 of 37

Prepared By: **Summers Engineering Collective**
- Jen Summers -
Summers.eng.collective@gmail.com

#	Date:	Revision:

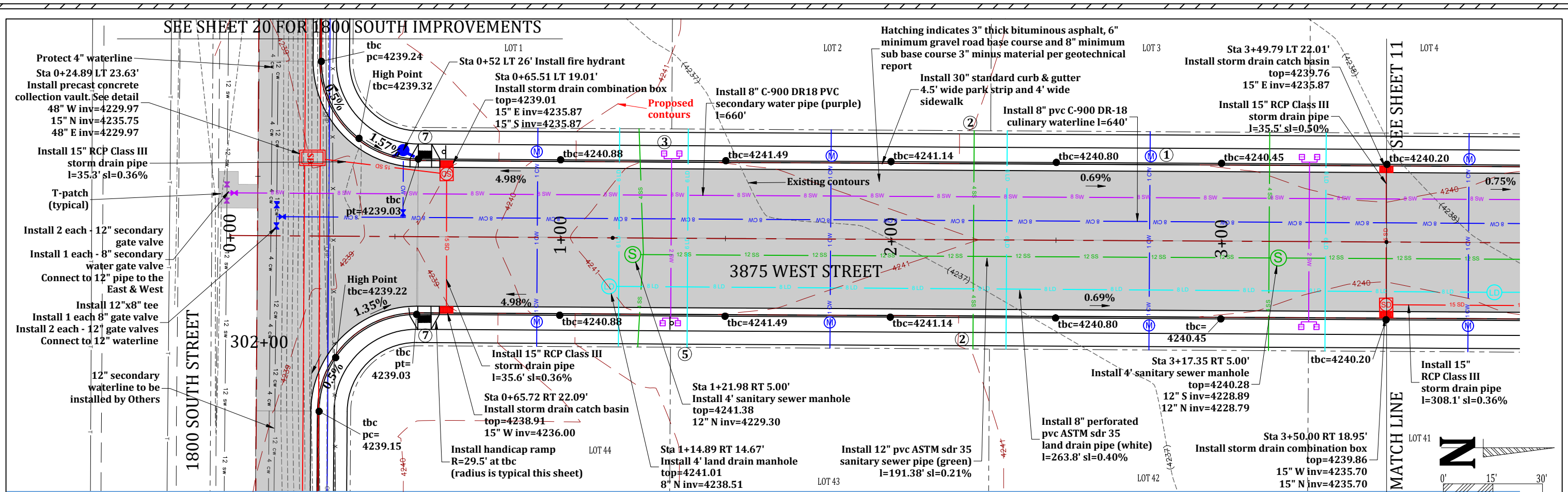

SEE SHEET 20 FOR 1800 SOUTH IMPROVEMENTS

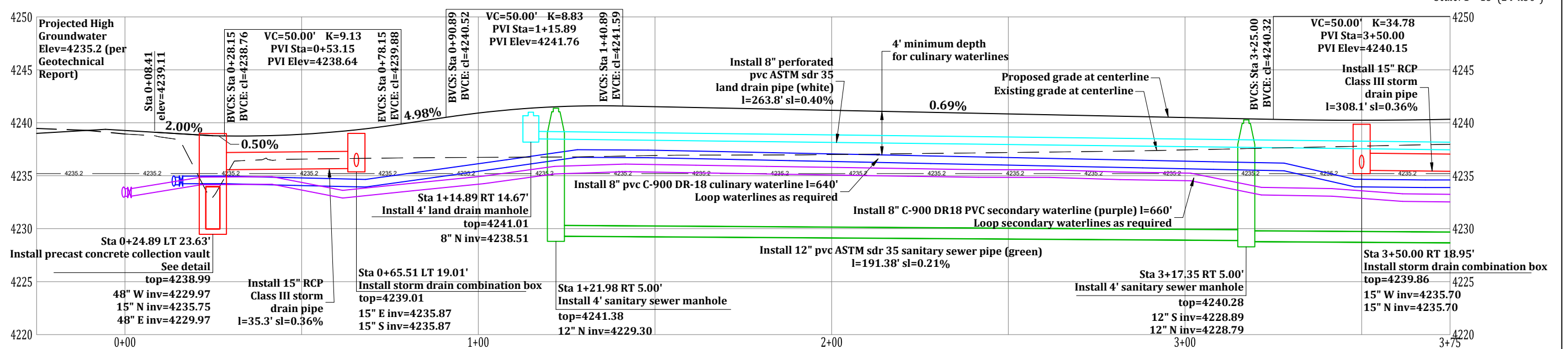
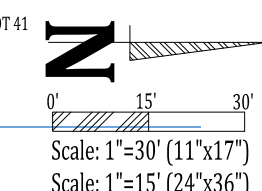

CONSTRUCTION NOTES:

1. Construct 1" copper water lateral and meter box (typical).
2. Install 4" pvc sanitary sewer lateral (typical) sl=2% minimum.
3. Install double service meter (typical). Install 1-1/2" CTS poly secondary water lateral.
4. Install service meter (typical). Install 1-1/2" CTS poly secondary water lateral.
5. Install 6" pvc Class 150 land drain lateral sl=1% minimum.
6. The land drain pipe must be perforated pvc wrapped with 1" clean gravel and fabric liner on all 4 sides of gravel (includes all 6" laterals).
7. All handicap ramps to meet APWA Plan 235.1 Example B Truncated Dome Gray in Color.
8. All fire hydrants shall meet Water District Standards.

Approved for Construction
Weber County Engineer
Date: _____

Developer:
Pat Burns
Lync Construction
801-710-2234

The Geotechnical Report provided by: CMT Engineering Laboratories (Project No. 10878, Dated March 7, 2018) has critical information in regards to this project and must be followed.

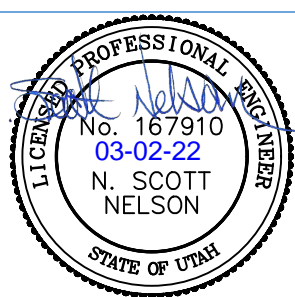

Project: **IMPROVEMENTS STAGECOACH ESTATES WEBER COUNTY, UTAH**

Title: **3875 WEST STREET PLAN & PROFILE: STA 0+00 - 3+50**

Date: 2 MARCH 2022

Prepared By: **Summers Engineering Collective**
- Jen Summers -
Summers.eng.collective@gmail.com

#	Date:	Revision:

Sheet 10 of 37

SEE SHEET 14 FOR 1700 SOUTH IMPROVEMENTS

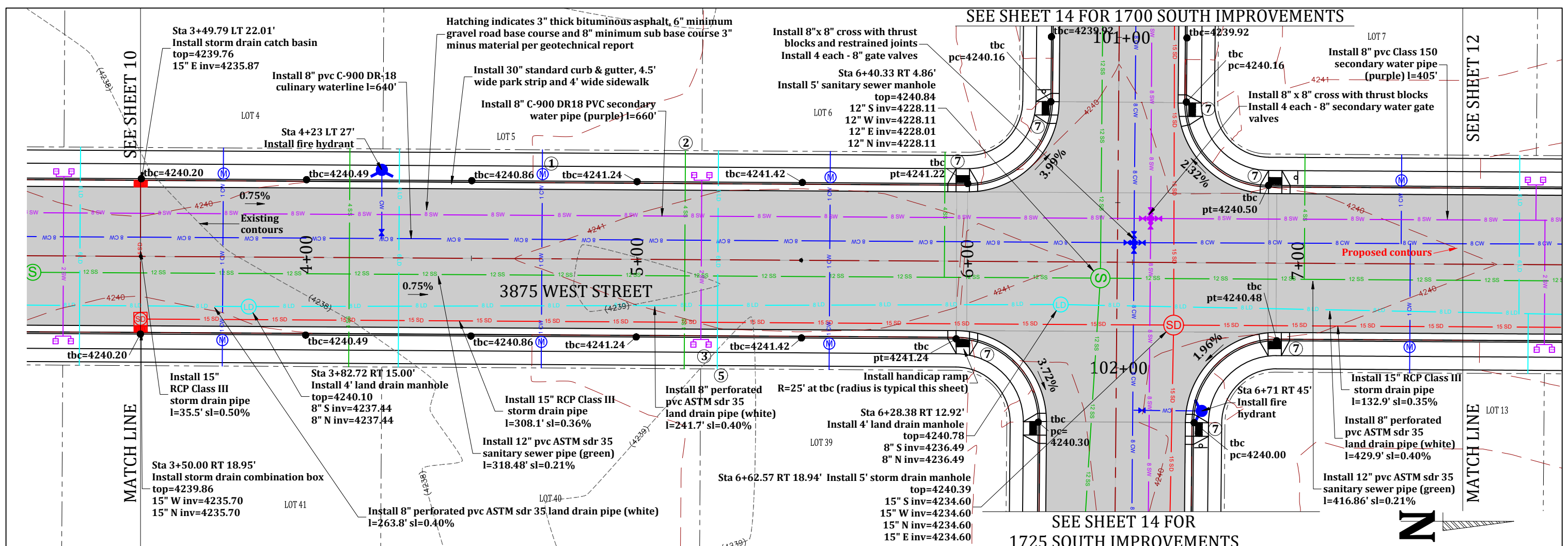

SEE SHEET 14 FOR 1725 SOUTH IMPROVEMENTS

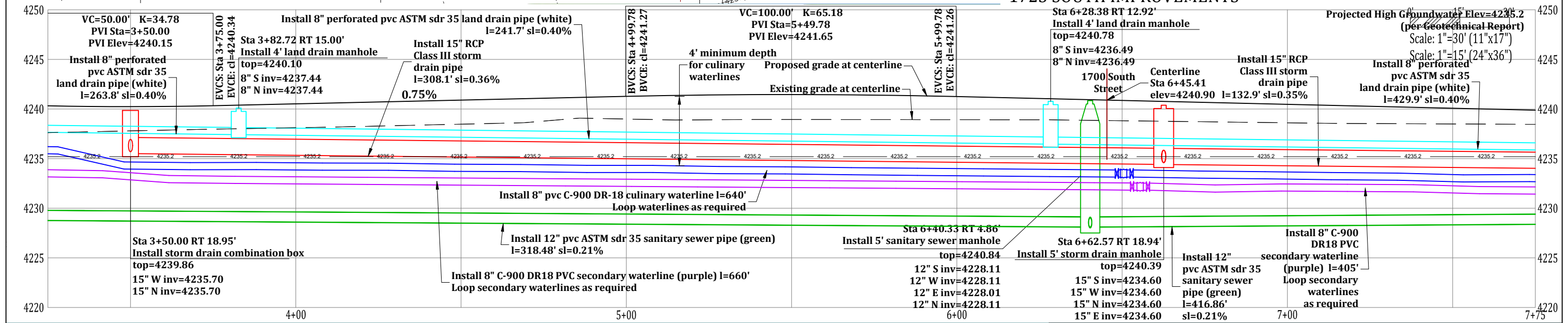

- CONSTRUCTION NOTES:**
1. Construct 1" copper water lateral and meter box (typical).
 2. Install 4" pvc sanitary sewer lateral (typical) sl=2% minimum.

3. Install double service meter (typical). Install 1-1/2" CTS poly secondary water lateral.
4. Install service meter (typical). Install 1-1/2" CTS poly secondary water lateral.

5. Install 6" pvc Class 150 land drain lateral sl=1% minimum.
6. The land drain pipe must be perforated pvc wrapped with 1" clean gravel and fabric liner on all 4 sides of gravel (includes all 6" laterals).

7. All handicap ramps to meet APWA Plan 235.1 Example B Truncated Dome Gray in Color.
8. All fire hydrants shall meet Water District Standards.

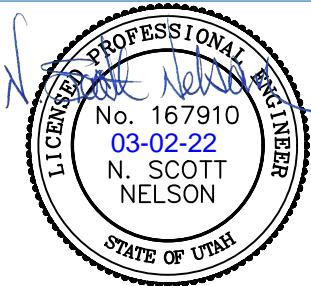

Approved for Construction
Weber County Engineer
Date: _____

Developer:
Pat Burns
Lync Construction
801-710-2234

The Geotechnical Report provided by: CMT Engineering Laboratories (Project No. 10878, Dated March 7, 2018) has critical information in regards to this project and must be followed.

Project: IMPROVEMENTS
STAGECOACH ESTATES
WEBER COUNTY, UTAH

Title: 3875 WEST STREET
PLAN & PROFILE: STA 3+50 - 7+50
Date: 2 MARCH 2022

Prepared By:
Summers Engineering Collective
- Jen Summers -
Summers.eng.collective@gmail.com

#	Date	Revision

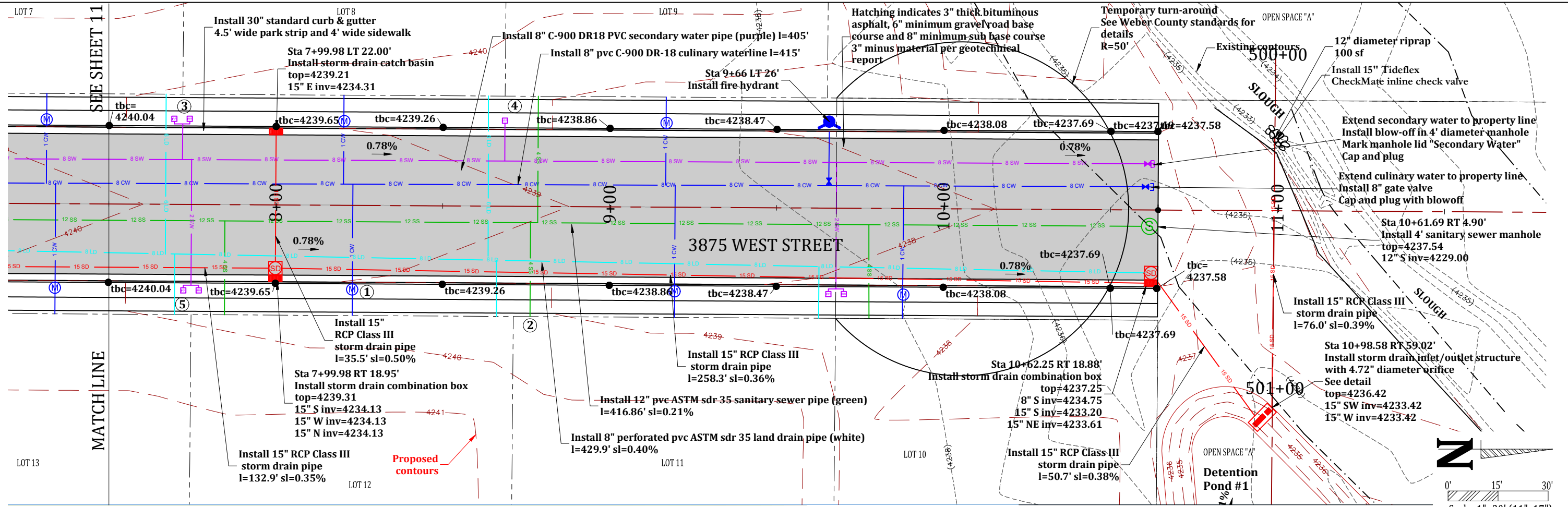

SEE SHEET 13 FOR DETENTION POND #1

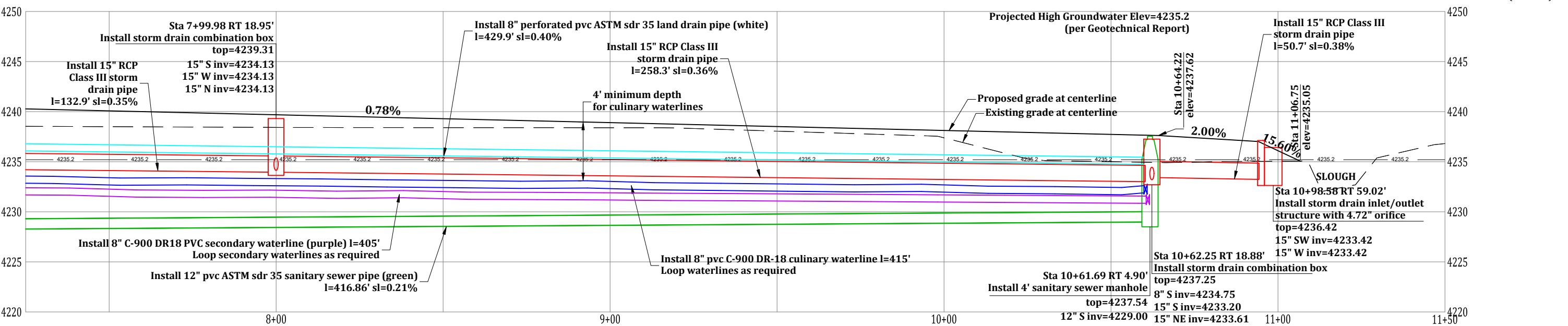

CONSTRUCTION NOTES:

1. Construct 1" copper water lateral and meter box (typical).
2. Install 4" pvc sanitary sewer lateral (typical) sl=2% minimum.
3. Install double service meter (typical). Install 1-1/2" CTS poly secondary water lateral.
4. Install service meter (typical). Install 1-1/2" CTS poly secondary water lateral.
5. Install 6" pvc Class 150 land drain lateral sl=1% minimum.
6. The land drain pipe must be perforated pvc wrapped with 1" clean gravel and fabric liner on all 4 sides of gravel (includes all 6" laterals).
7. All handicap ramps to meet APWA Plan 235.1 Example B Truncated Dome Gray in Color.
8. All fire hydrants shall meet Water District Standards.

Approved for Construction
Weber County Engineer
Date: _____

Developer:
Pat Burns
Lync Construction
801-710-2234

The Geotechnical Report provided by: CMT Engineering Laboratories (Project No. 10878, Dated March 7, 2018) has critical information in regards to this project and must be followed.

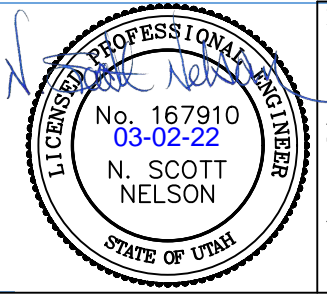

Project: **IMPROVEMENTS STAGECOACH ESTATES WEBER COUNTY, UTAH**

Title: **3875 WEST STREET PLAN & PROFILE: STA 7+50 - 11+25**

Date: 2 MARCH 2022

Sheet 12 of 37

Prepared By: **Summers Engineering Collective**
- Jen Summers -
Summers.eng.collective@gmail.com

#	Date:	Revision:

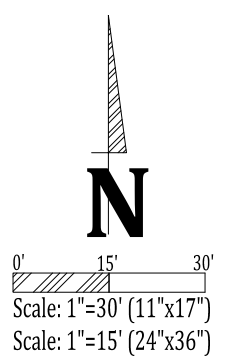
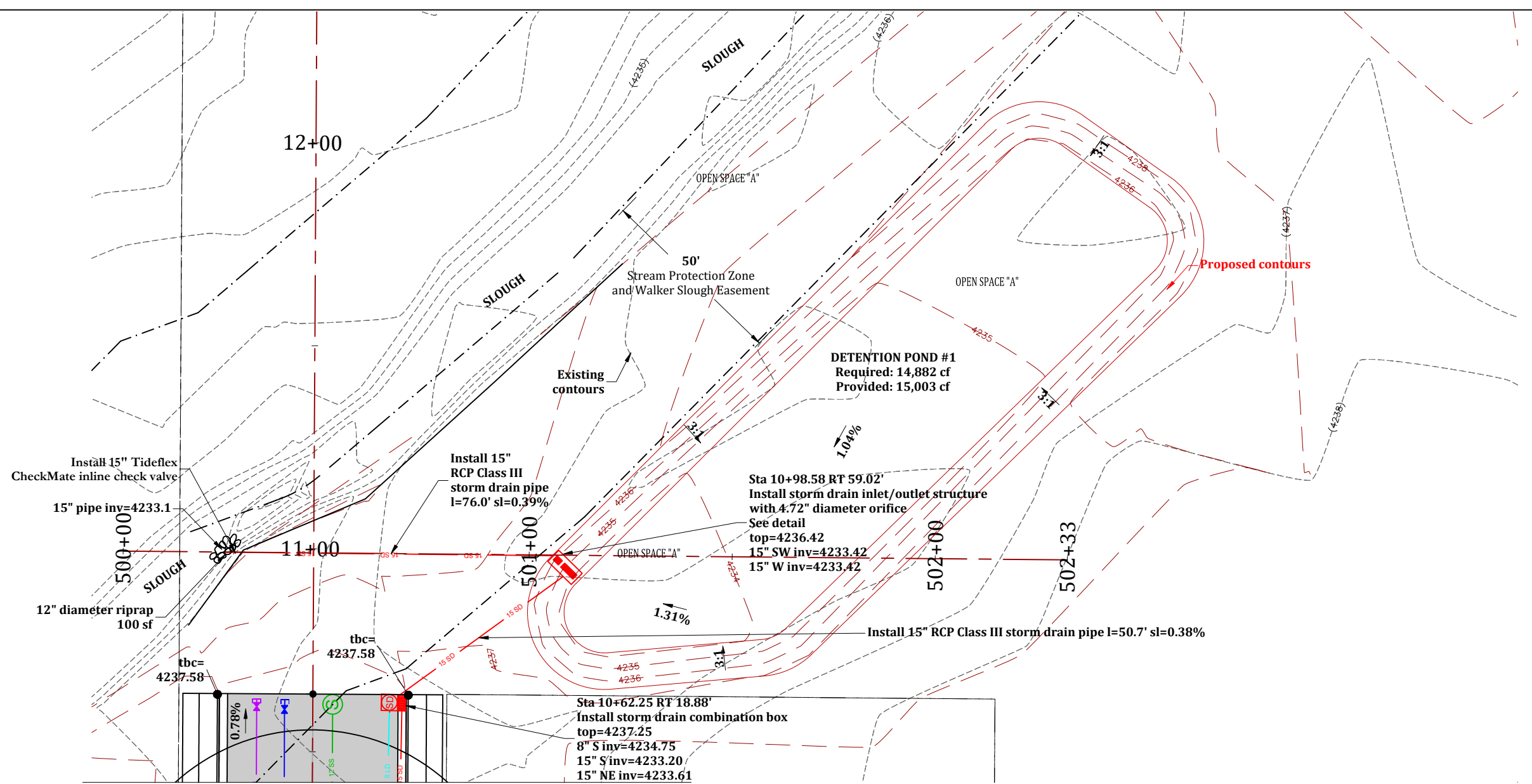

SEE SHEET 12 FOR 1375 WEST STREET

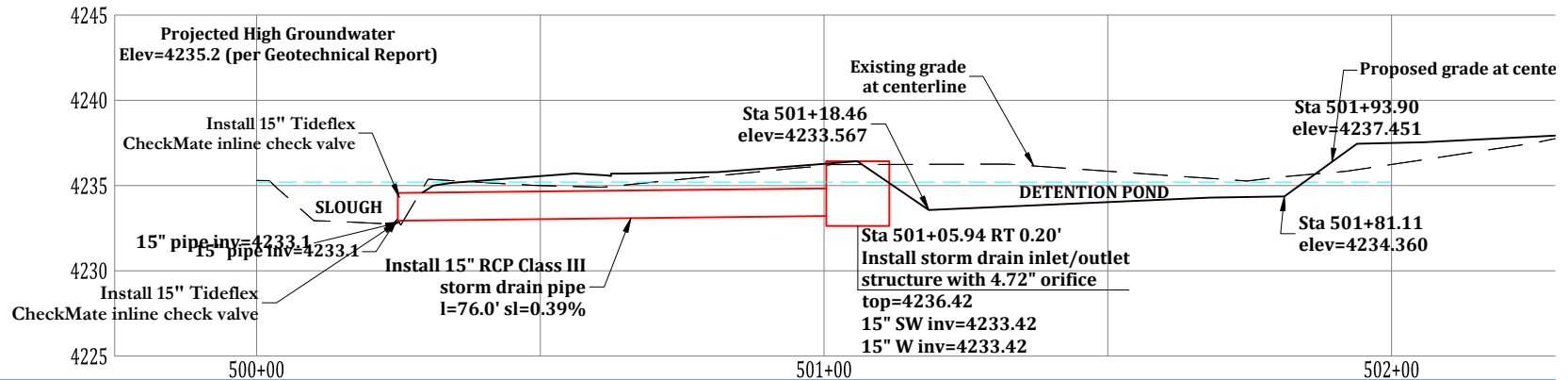

CONSTRUCTION NOTES:
 1. Construct 1" copper water lateral and meter box (typical).
 2. Install 4" pvc sanitary sewer lateral (typical) sl=2% minimum.

3. Install double service meter (typical). Install 1-1/2" CTS poly secondary water lateral.
 4. Install service meter (typical). Install 1-1/2" CTS poly secondary water lateral.

5. Install 6" pvc Class 150 land drain lateral sl=1% minimum.
 6. The land drain pipe must be perforated pvc wrapped with 1" clean gravel and fabric liner on all 4 sides of gravel (includes all 6" laterals).

7. All handicap ramps to meet APWA Plan 235.1 Example B Truncated Dome Gray in Color.
 8. All fire hydrants shall meet Water District Standards.

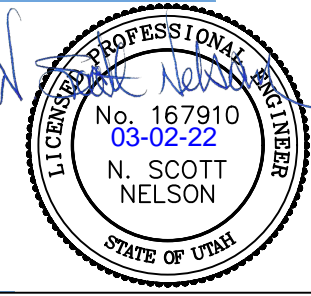

Approved for Construction
 Weber County Engineer
 Date: _____

Developer:
 Pat Burns
 Lync Construction
 801-710-2234

The Geotechnical Report provided by: CMT Engineering Laboratories (Project No. 10878, Dated March 7, 2018) has critical information in regards to this project and must be followed.

Project: **IMPROVEMENTS STAGECOACH ESTATES WEBER COUNTY, UTAH**
 Title: **DETENTION POND #1 PLAN & PROFILE: STA 10+50 - 11+00**
 Date: 2 MARCH 2022

Prepared By: **Summers Engineering Collective**
 - Jen Summers -
 Summers.eng.collective@gmail.com

#	Date	Revision

Sheet 13 of 37

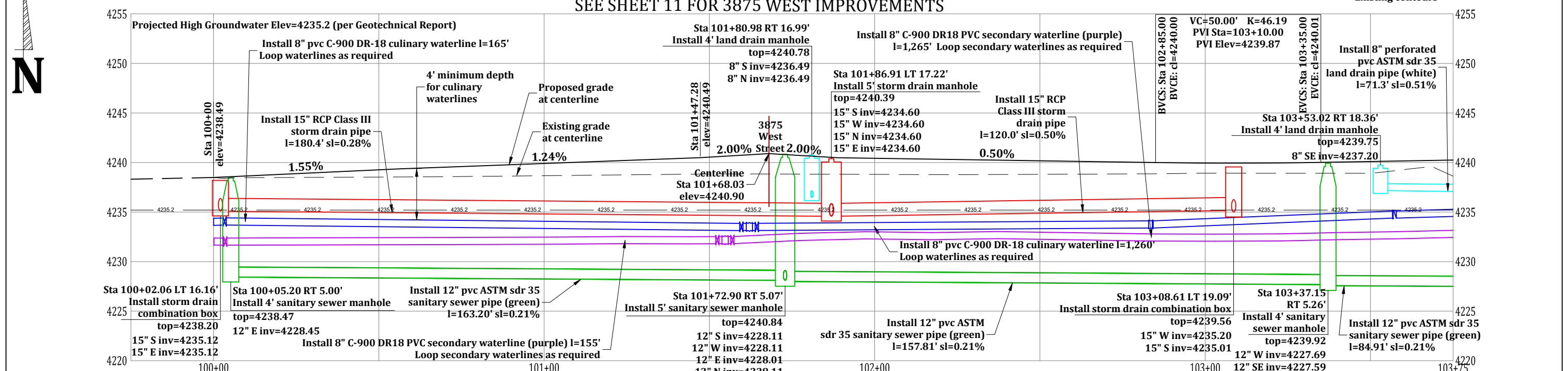
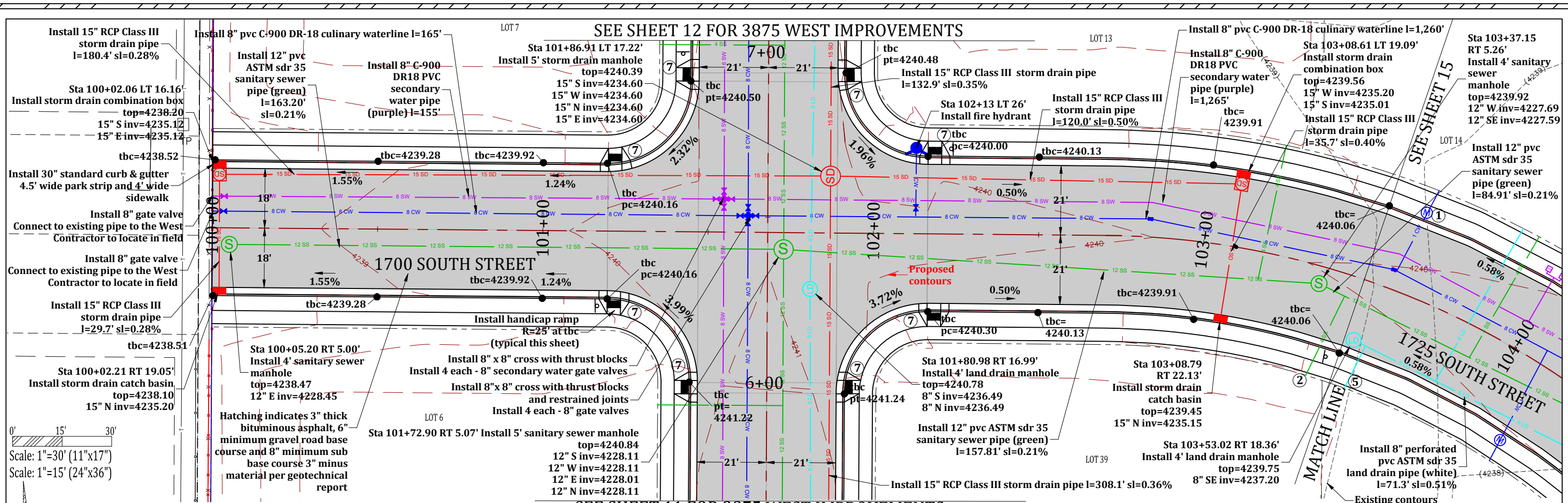

CONSTRUCTION NOTES:

- Construct 1" copper water lateral and meter box (typical).
- Install 4" pvc sanitary sewer lateral (typical) sl=2% minimum.
- Install double service meter (typical). Install 1-1/2" CTS poly secondary water lateral.
- Install service meter (typical). Install 1-1/2" CTS poly secondary water lateral.
- Install 6" pvc Class 150 land drain lateral sl=1% minimum.
- The land drain pipe must be perforated pvc wrapped with 1" clean gravel and fabric liner on all 4 sides of gravel (includes all 6" laterals).
- All handicap ramps to meet APWA Plan 235.1 Example B Truncated Dome Gray in Color.
- All fire hydrants shall meet Water District Standards.

Approved for Construction
Weber County Engineer
Date: _____

Developer:
Pat Burns
Lync Construction
801-710-2234

The Geotechnical Report provided by: CMT Engineering Laboratories (Project No. 10878, Dated March 7, 2018) has critical information in regards to this project and must be followed.

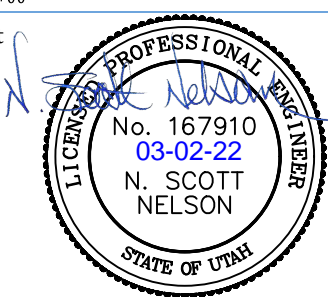

Project: **IMPROVEMENTS STAGECOACH ESTATES WEBER COUNTY, UTAH**

Title: **1700/1725 SOUTH STREET PLAN & PROFILE: STA 100+00 - 103+50**

Date: 2 MARCH 2022

Prepared By: **Summers Engineering Collective**
- Jen Summers -
Summers.eng.collective@gmail.com

#	Date	Revision

Sheet 14 of 37

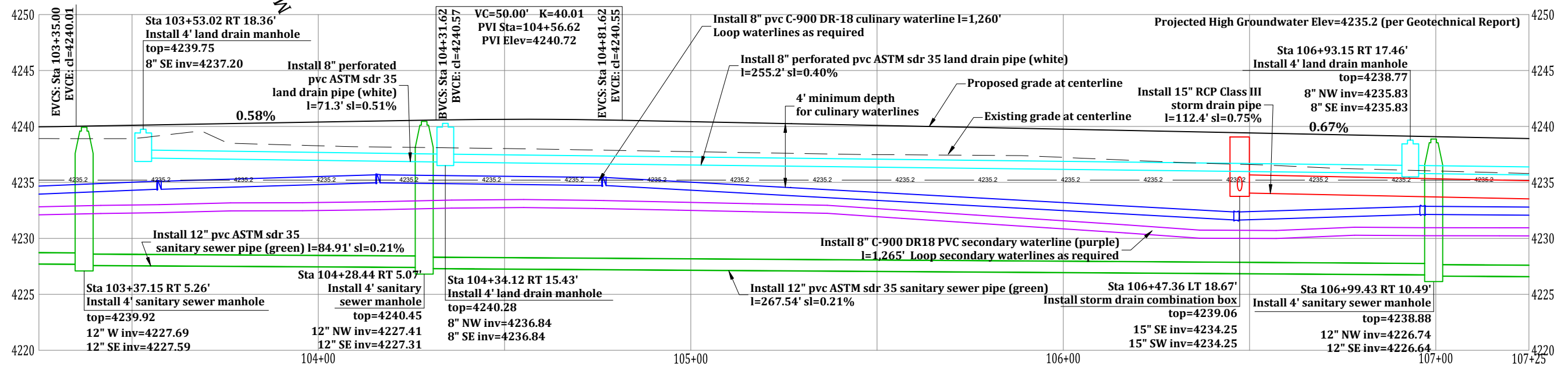
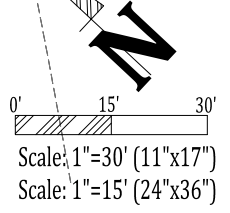
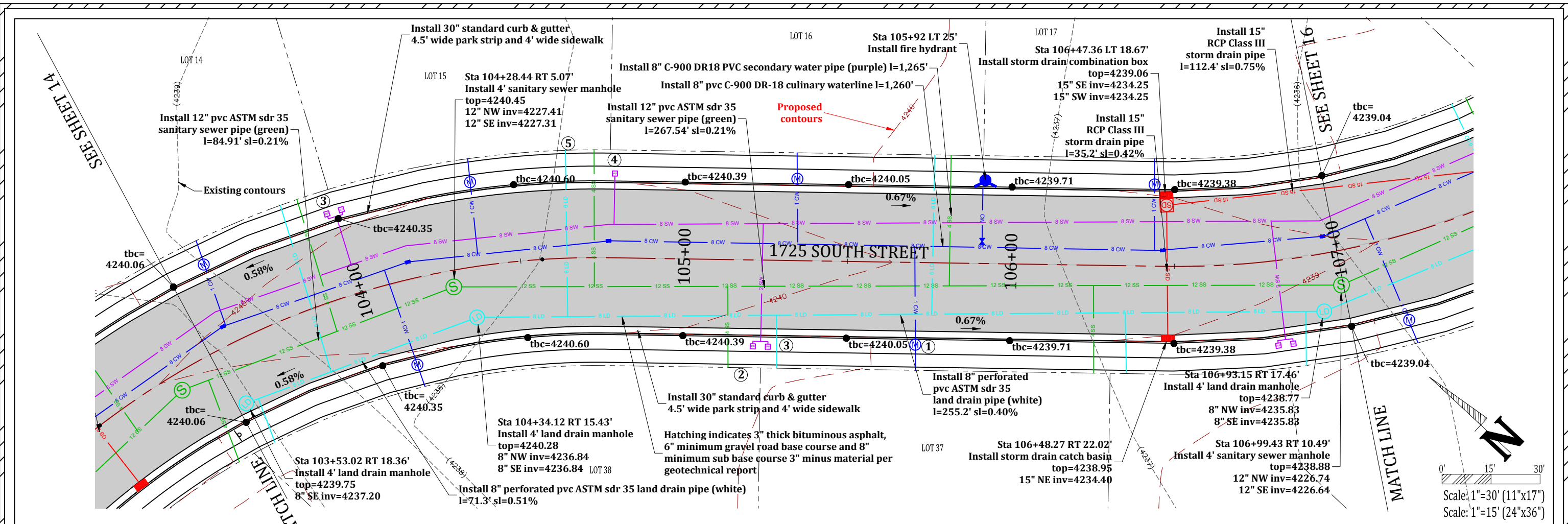

CONSTRUCTION NOTES:

1. Construct 1" copper water lateral and meter box (typical).
2. Install 4" pvc sanitary sewer lateral (typical) sl=2% minimum.
3. Install double service meter (typical). Install 1-1/2" CTS poly secondary water lateral.
4. Install service meter (typical). Install 1-1/2" CTS poly secondary water lateral.
5. Install 6" pvc Class 150 land drain lateral sl=1% minimum.
6. The land drain pipe must be perforated pvc wrapped with 1" clean gravel and fabric liner on all 4 sides of gravel (includes all 6" laterals).
7. All handicap ramps to meet APWA Plan 235.1 Example B Truncated Dome Gray in Color.
8. All fire hydrants shall meet Water District Standards.

Approved for Construction
Weber County Engineer
Date: _____

Developer:
Pat Burns
Lync Construction
801-710-2234

The Geotechnical Report provided by: CMT Engineering Laboratories (Project No. 10878, Dated March 7, 2018) has critical information in regards to this project and must be followed.

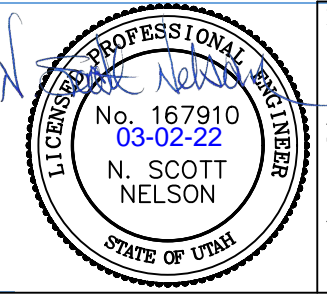

Project: **IMPROVEMENTS STAGECOACH ESTATES WEBER COUNTY, UTAH**

Title: **1725 SOUTH STREET PLAN & PROFILE: STA 103+50 - 107+00**

Date: 2 MARCH 2022

Sheet 15 of 37

Prepared By: **Summers Engineering Collective**
- Jen Summers -
Summers.eng.collective@gmail.com

#	Date:	Revision:

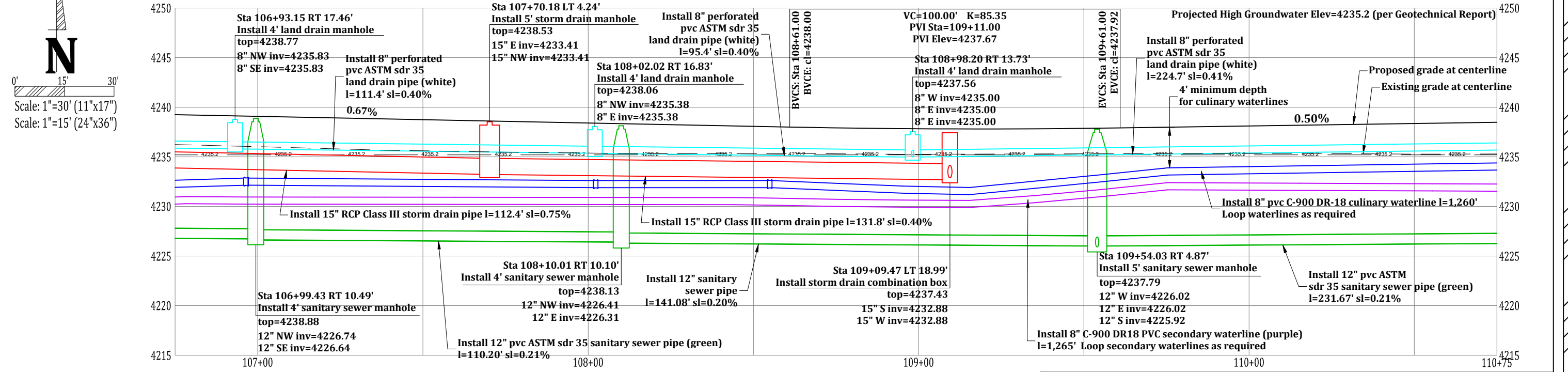
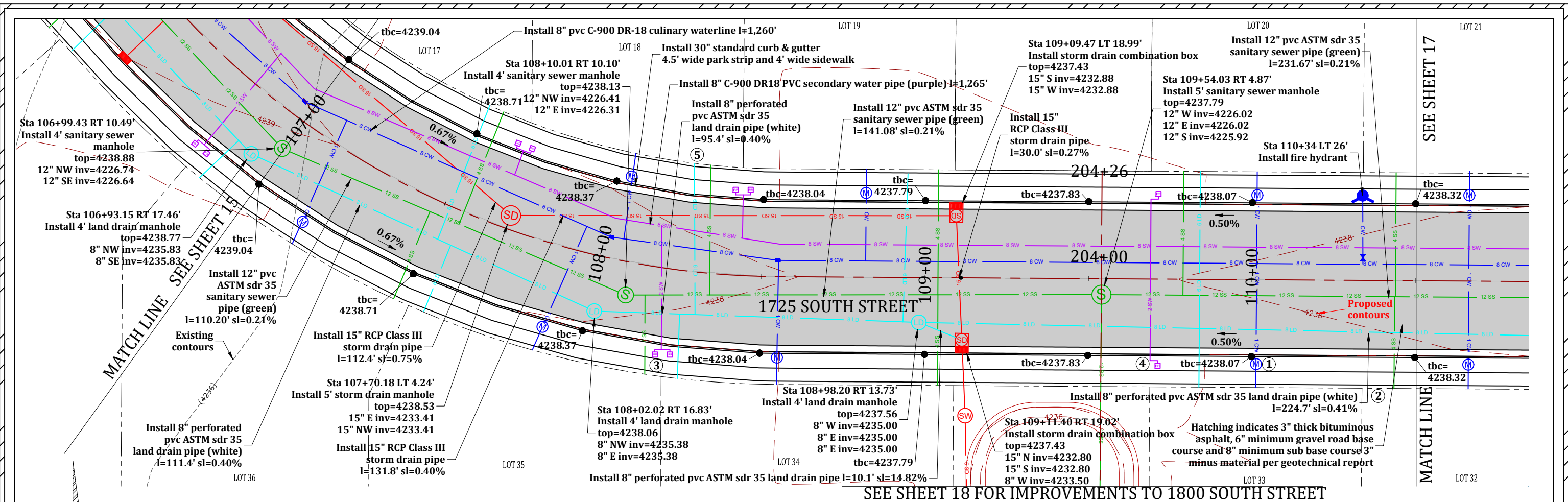

CONSTRUCTION NOTES:
 1. Construct 1" copper water lateral and meter box (typical).
 2. Install 4" pvc sanitary sewer lateral (typical) sl=2% minimum.

3. Install double service meter (typical). Install 1-1/2" CTS poly secondary water lateral.
 4. Install service meter (typical). Install 1-1/2" CTS poly secondary water lateral.

5. Install 6" pvc Class 150 land drain lateral sl=1% minimum.
 6. The land drain pipe must be perforated pvc wrapped with 1" clean gravel and fabric liner on all 4 sides of gravel (includes all 6" laterals).

7. All handicap ramps to meet APWA Plan 235.1 Example B Truncated Dome Gray in Color.
 8. All fire hydrants shall meet Water District Standards.

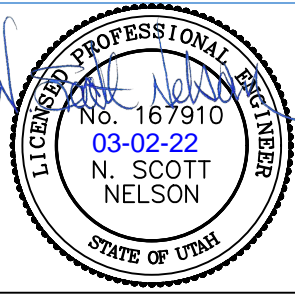

Approved for Construction
 Weber County Engineer
 Date: _____

Developer:
 Pat Burns
 Lync Construction
 801-710-2234

The Geotechnical Report provided by: CMT Engineering Laboratories (Project No. 10878, Dated March 7, 2018) has critical information in regards to this project and must be followed.

Project: **IMPROVEMENTS STAGECOACH ESTATES WEBER COUNTY, UTAH**
 Title: **1725 SOUTH STREET PLAN & PROFILE: STA 107+00 - 110+50**
 Date: 2 MARCH 2022

Prepared By: **Summers Engineering Collective**
 - Jen Summers -
 Summers.eng.collective@gmail.com

#	Date:	Revision:

Sheet 16 of 37

SEE SHEET 19 FOR IMPROVEMENTS TO DETENTION POND #3

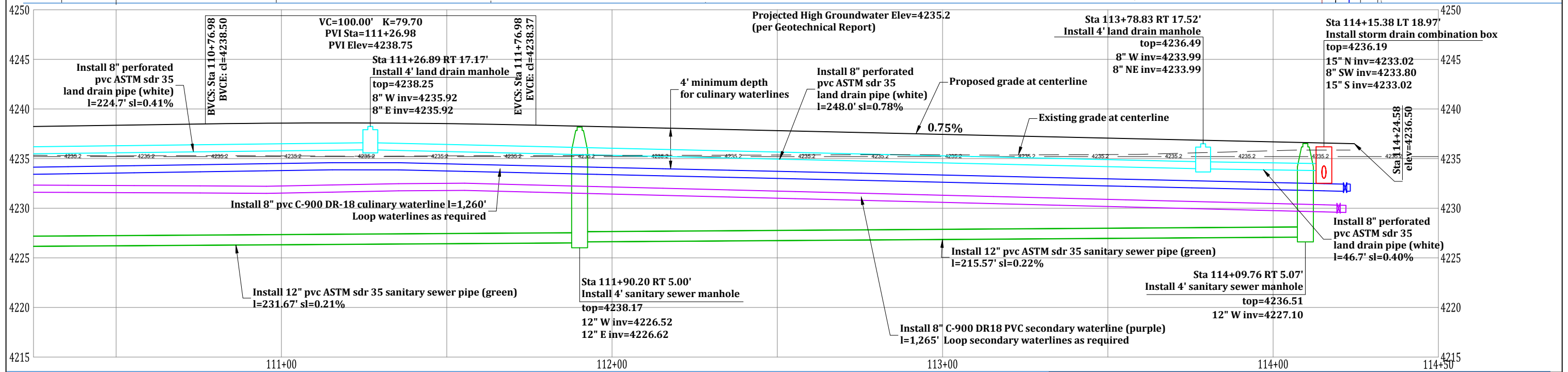
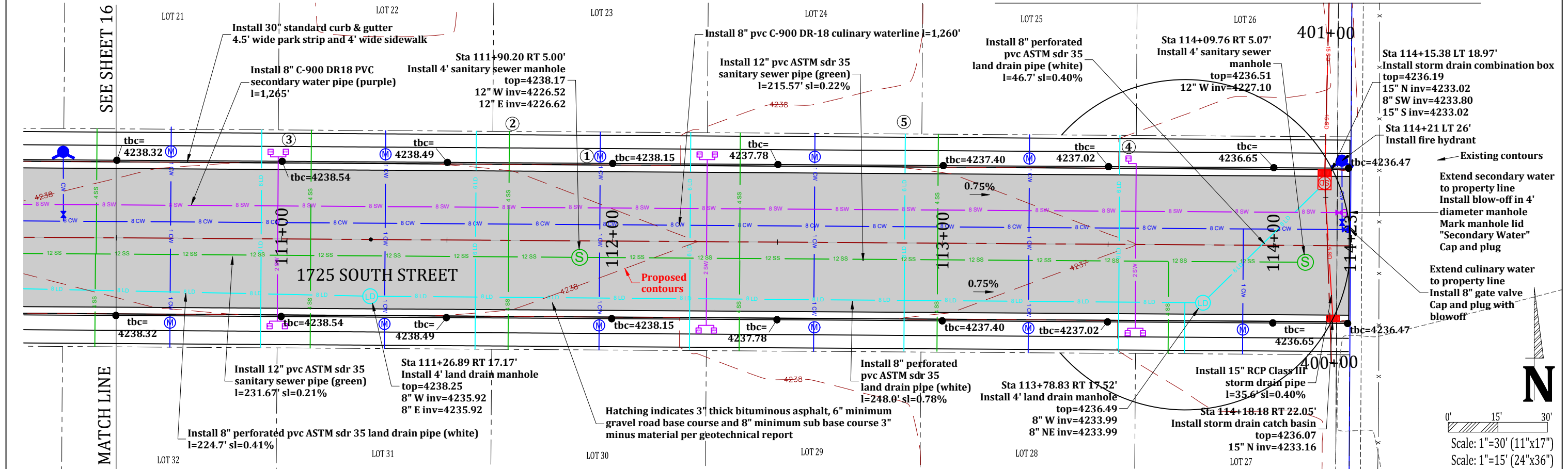

- CONSTRUCTION NOTES:**
1. Construct 1" copper water lateral and meter box (typical).
 2. Install 4" pvc sanitary sewer lateral (typical) sl=2% minimum.
 3. Install double service meter (typical). Install 1-1/2" CTS poly secondary water lateral.
 4. Install service meter (typical). Install 1-1/2" CTS poly secondary water lateral.
 5. Install 6" pvc Class 150 land drain lateral sl=1% minimum.
 6. The land drain pipe must be perforated pvc wrapped with 1" clean gravel and fabric liner on all 4 sides of gravel (includes all 6" laterals).
 7. All handicap ramps to meet APWA Plan 235.1 Example B Truncated Dome Gray in Color.
 8. All fire hydrants shall meet Water District Standards.

Developer:
Pat Burns
Lync Construction
801-710-2234

The Geotechnical Report provided by: CMT Engineering Laboratories (Project No. 10878, Dated March 7, 2018) has critical information in regards to this project and must be followed.

Approved for Construction
Weber County Engineer
Date: _____

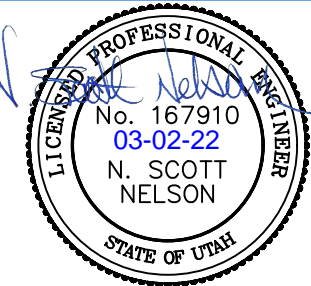

Project: **IMPROVEMENTS STAGECOACH ESTATES WEBER COUNTY, UTAH**

Title: **1725 SOUTH STREET PLAN & PROFILE: STA 110+50 - 114+23**

Date: 2 MARCH 2022

Prepared By: **Summers Engineering Collective**
- Jen Summers -
Summers.eng.collective@gmail.com

#	Date	Revision

SEE SHEET 22 FOR 1800 SOUTH IMPROVEMENTS

SEE SHEET 16 FOR 1725 WEST STREET IMPROVEMENTS

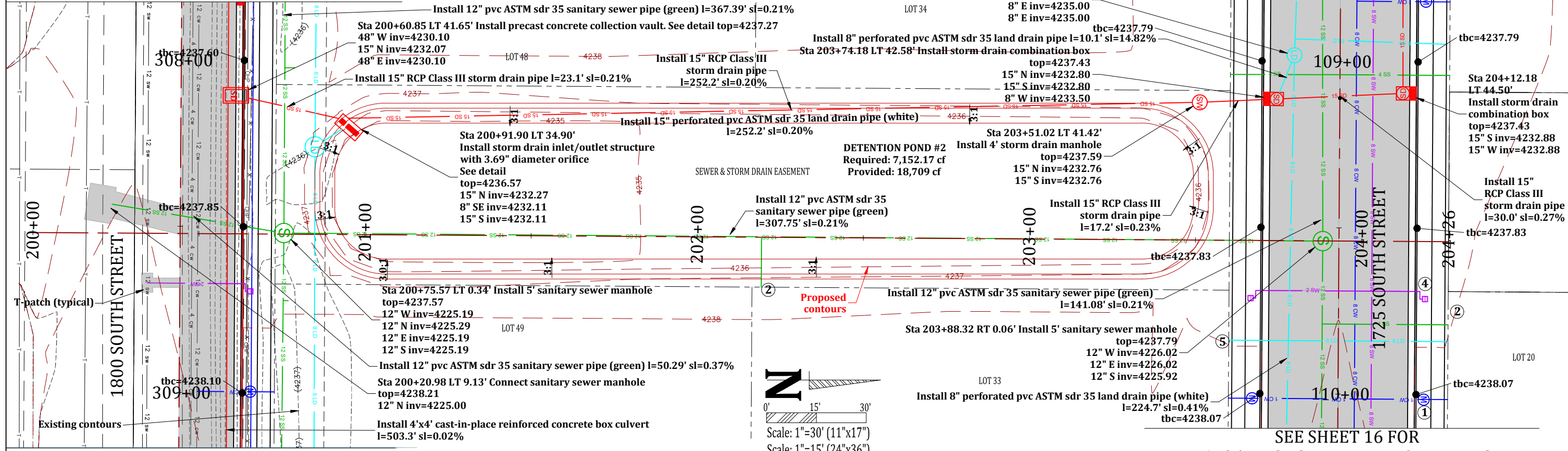

SEE SHEET 22 FOR 1800 SOUTH IMPROVEMENTS

SEE SHEET 16 FOR 1725 WEST STREET IMPROVEMENTS

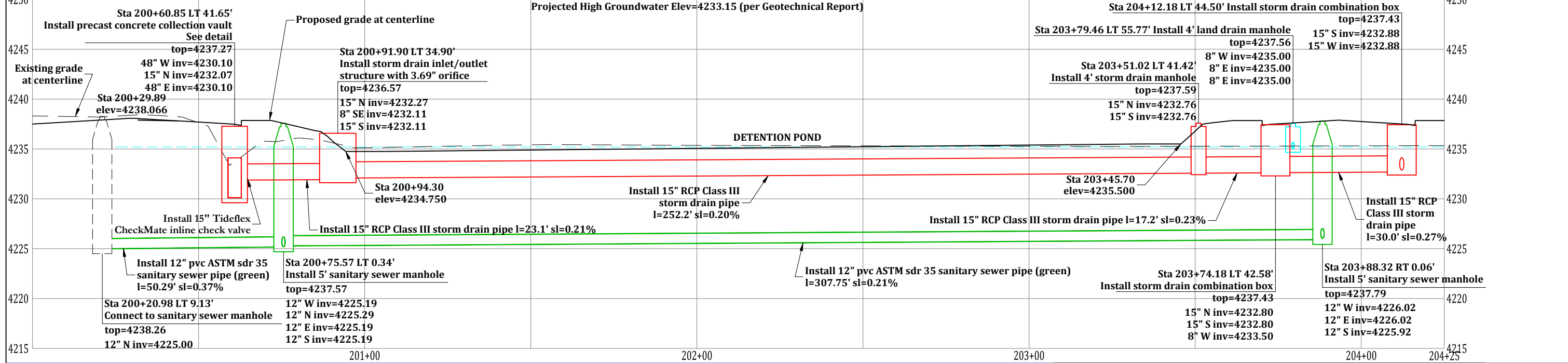

- Construct 1" copper water lateral and meter box (typical).
- Install 4" pvc sanitary sewer lateral (typical) sl=2% minimum.
- Install double service meter (typical). Install 1-1/2" CTS poly secondary water lateral.
- Install service meter (typical). Install 1-1/2" CTS poly secondary water lateral.
- Install 6" pvc Class 150 land drain lateral sl=1% minimum.
- The land drain pipe must be perforated pvc wrapped with 1" clean gravel and fabric liner on all 4 sides of gravel (includes all 6" laterals).
- All handicap ramps to meet APWA Plan 235.1 Example B Truncated Dome Gray in Color.
- All fire hydrants shall meet Water District Standards.

Approved for Construction
Weber County Engineer
Date: _____

Developer:
Pat Burns
Lync Construction
801-710-2234

The Geotechnical Report provided by: CMT Engineering Laboratories (Project No. 10878, Dated March 7, 2018) has critical information in regards to this project and must be followed.

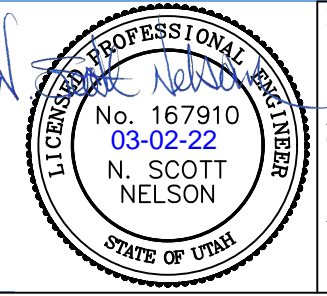

Project: **IMPROVEMENTS STAGECOACH ESTATES WEBER COUNTY, UTAH**

Title: **DETENTION POND #2 PLAN & PROFILE: STA 200+00 - 204+26**

Date: 2 MARCH 2022

Sheet 18 of 37

Prepared By: **Summers Engineering Collective**
- Jen Summers -
Summers.eng.collective@gmail.com

#	Date:	Revision:

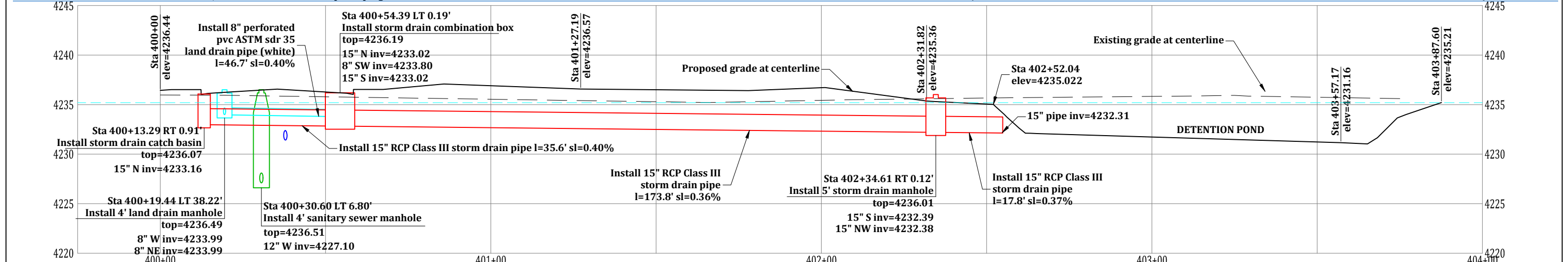
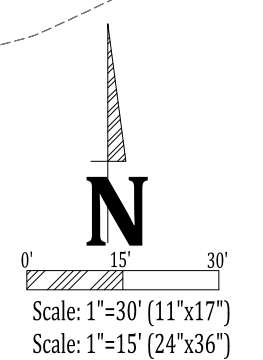
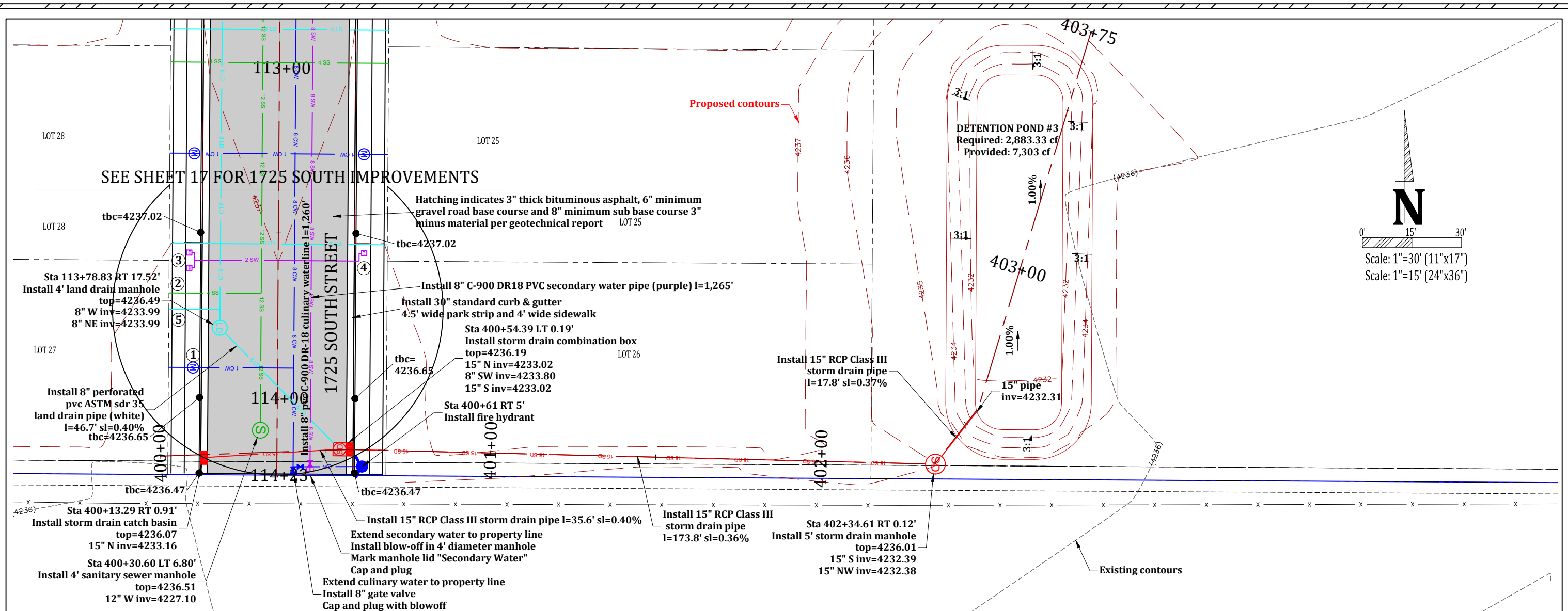

- CONSTRUCTION NOTES:**
1. Construct 1" copper water lateral and meter box (typical).
 2. Install 4" pvc sanitary sewer lateral (typical) sl=2% minimum.
 3. Install double service meter (typical). Install 1-1/2" CTS poly secondary water lateral.
 4. Install service meter (typical). Install 1-1/2" CTS poly secondary water lateral.
 5. Install 6" pvc Class 150 land drain lateral sl=1% minimum.
 6. The land drain pipe must be perforated pvc wrapped with 1" clean gravel and fabric liner on all 4 sides of gravel (includes all 6" laterals).
 7. All handicap ramps to meet APWA Plan 235.1 Example B Truncated Dome Gray in Color.
 8. All fire hydrants shall meet Water District Standards.

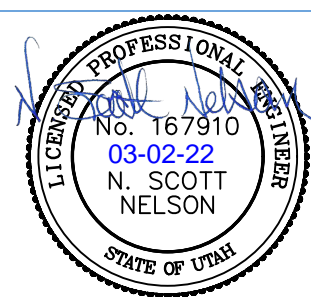

Project: **IMPROVEMENTS
STAGECOACH ESTATES
WEBER COUNTY, UTAH**

Title: **DETENTION POND #3
PLAN & PROFILE: STA 400+00 - 403+75**

Date: 2 MARCH 2022

Prepared By: **Summers Engineering Collective**
- Jen Summers -
Summers.eng.collective@gmail.com

#	Date:	Revision:

Sheet 19 of 37

The Geotechnical Report provided by: CMT Engineering Laboratories (Project No. 10878, Dated March 7, 2018) has critical information in regards to this project and must be followed.

Approved for Construction
Weber County Engineer
Date: _____

Developer:
Pat Burns
Lync Construction
801-710-2234

SEE SHEET 10 FOR 3875 WEST STREET IMPROVEMENTS

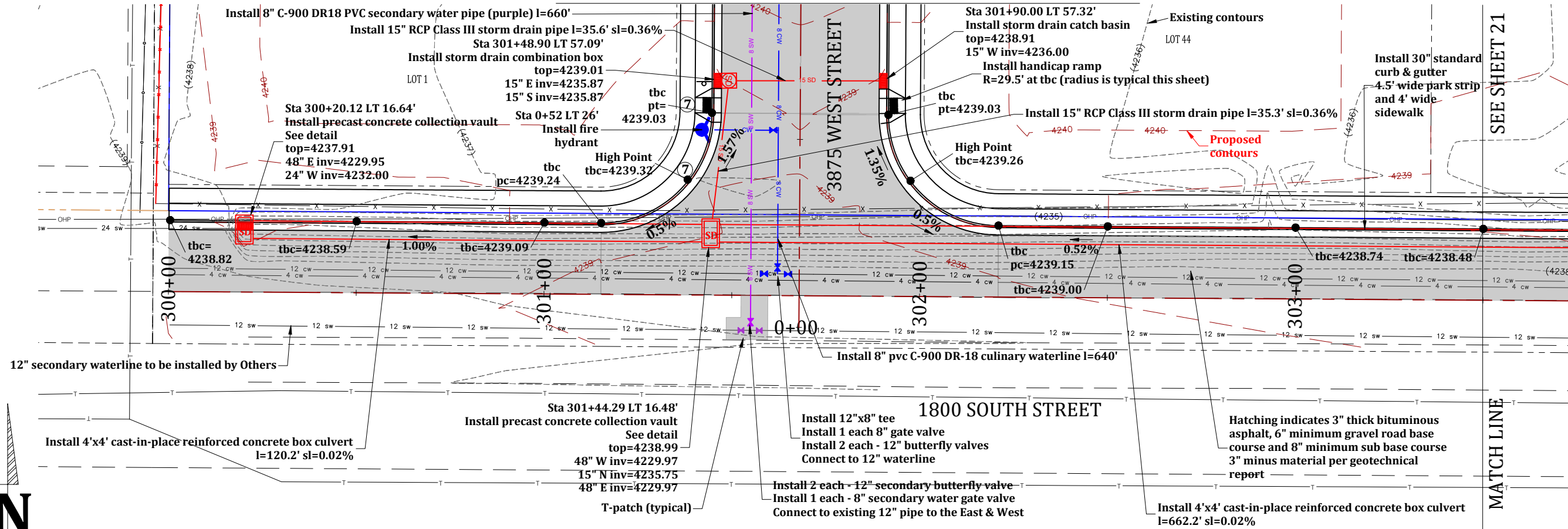

Scale: 1"=30' (11"x17")
Scale: 1"=15' (24"x36")

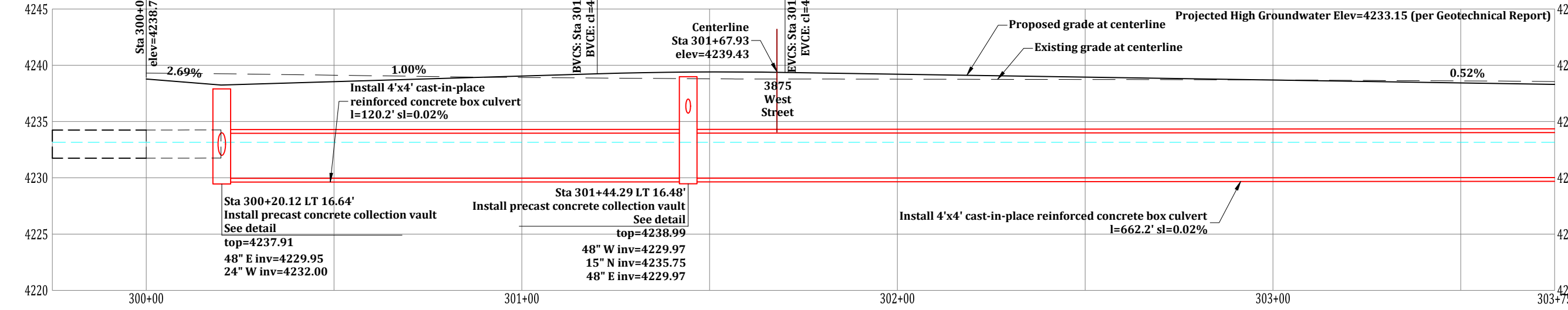

CONSTRUCTION NOTES:

- Construct 1" copper water lateral and meter box (typical).
- Install 4" pvc sanitary sewer lateral (typical) sl=2% minimum.
- Install double service meter (typical). Install 1-1/2" CTS poly secondary water lateral.
- Install service meter (typical). Install 1-1/2" CTS poly secondary water lateral.
- Install 6" pvc Class 150 land drain lateral sl=1% minimum.
- The land drain pipe must be perforated pvc wrapped with 1" clean gravel and fabric liner on all 4 sides of gravel (includes all 6" laterals).
- All handicap ramps to meet APWA Plan 235.1 Example B Truncated Dome Gray in Color.
- All fire hydrants shall meet Water District Standards.

Approved for Construction
Weber County Engineer
Date: _____

Developer:
Pat Burns
Lync Construction
801-710-2234

The Geotechnical Report provided by: CMT Engineering Laboratories (Project No. 10878, Dated March 7, 2018) has critical information in regards to this project and must be followed.

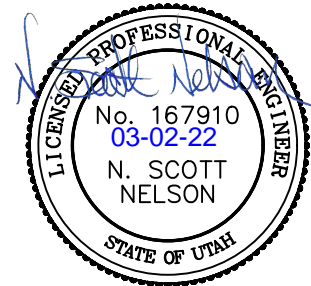

Project: IMPROVEMENTS STAGECOACH ESTATES WEBER COUNTY, UTAH
Title: 1800 SOUTH STREET PLAN & PROFILE: STA 300+00 - 303+50
Date: 2 MARCH 2022 | Sheet 20 of 37

Prepared By: Summers Engineering Collective - Jen Summers - Summers.eng.collective@gmail.com

#	Date:	Revision:

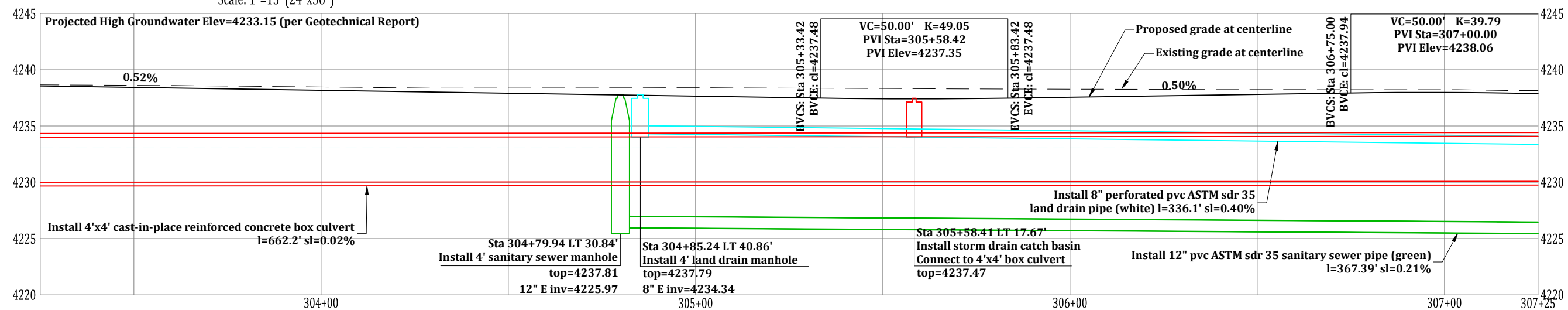
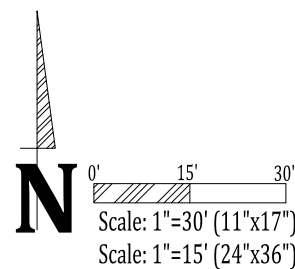
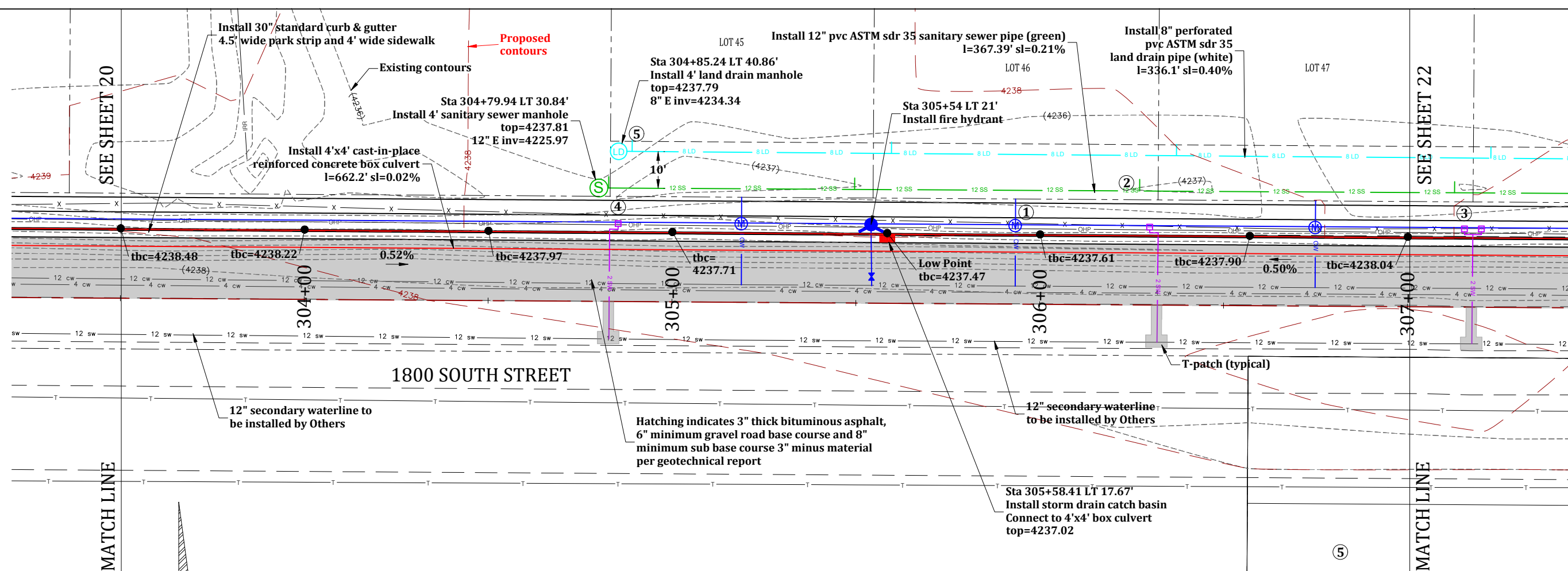

CONSTRUCTION NOTES:

1. Construct 1" copper water lateral and meter box (typical).
2. Install 4" pvc sanitary sewer lateral (typical) sl=2% minimum.
3. Install double service meter (typical). Install 1-1/2" CTS poly secondary water lateral.
4. Install service meter (typical). Install 1-1/2" CTS poly secondary water lateral.
5. Install 6" pvc Class 150 land drain lateral sl=1% minimum.
6. The land drain pipe must be perforated pvc wrapped with 1" clean gravel and fabric liner on all 4 sides of gravel (includes all 6" laterals).
7. All handicap ramps to meet APWA Plan 235.1 Example B Truncated Dome Gray in Color.
8. All fire hydrants shall meet Water District Standards.

Approved for Construction
Weber County Engineer
Date: _____

Developer:
Pat Burns
Lync Construction
801-710-2234

The Geotechnical Report provided by: CMT Engineering Laboratories (Project No. 10878, Dated March 7, 2018) has critical information in regards to this project and must be followed.

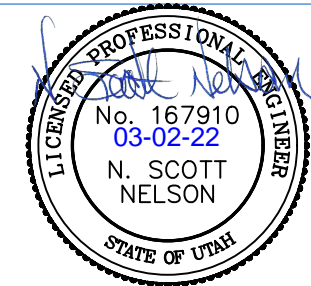

Project: **IMPROVEMENTS STAGECOACH ESTATES WEBER COUNTY, UTAH**

Title: **1800 SOUTH STREET PLAN & PROFILE: STA 303+50 - 307+00**

Date: 2 MARCH 2022

Prepared By: **Summers Engineering Collective**
- Jen Summers -
Summers.eng.collective@gmail.com

#	Date:	Revision:

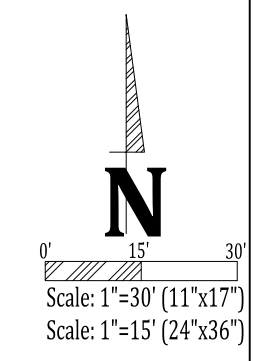
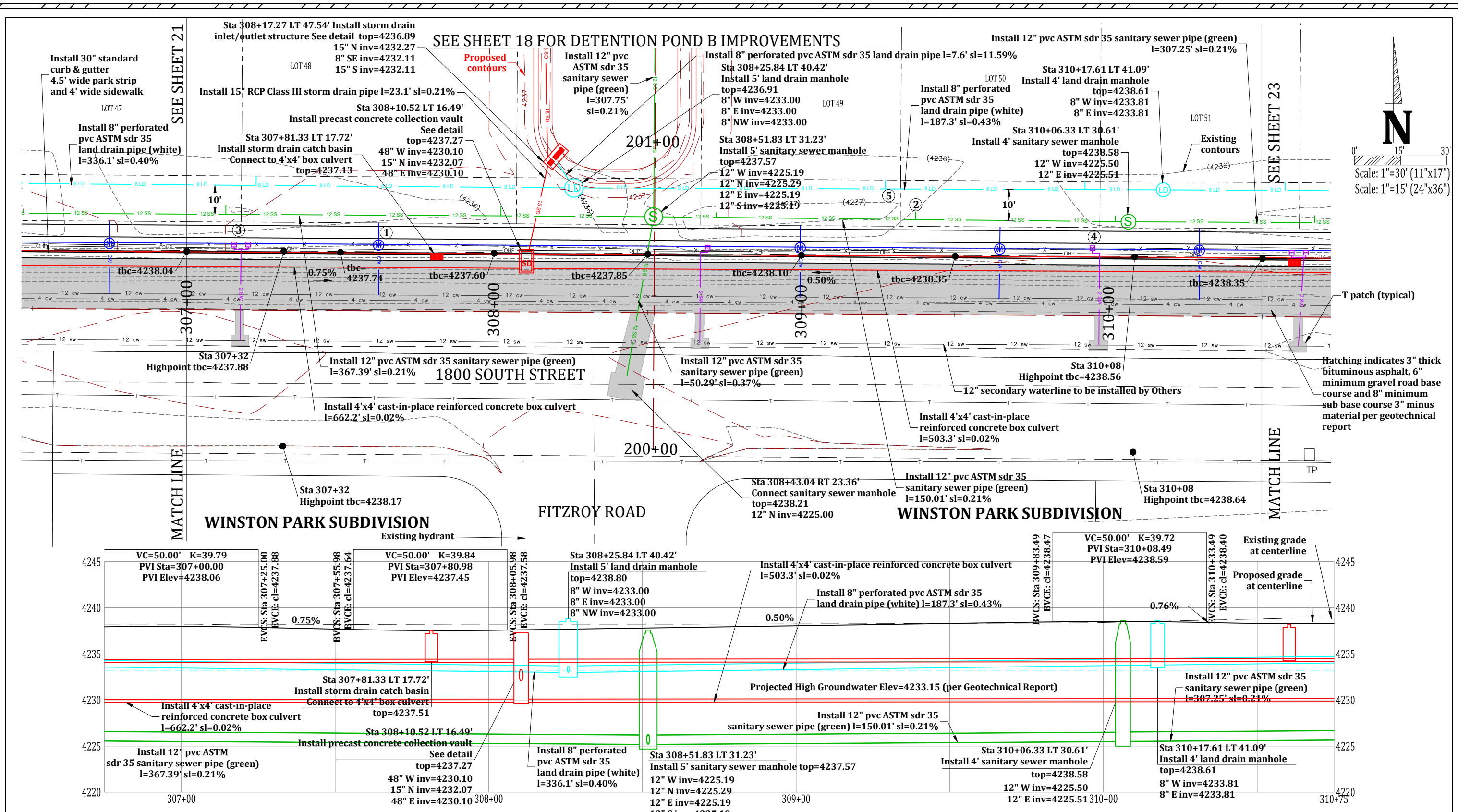

- CONSTRUCTION NOTES:**
1. Construct 1" copper water lateral and meter box (typical).
 2. Install 4" pvc sanitary sewer lateral (typical) sl=2% minimum.

3. Install double service meter (typical). Install 1-1/2" CTS poly secondary water lateral.
4. Install service meter (typical). Install 1-1/2" CTS poly secondary water lateral.

5. Install 6" pvc Class 150 land drain lateral sl=1% minimum.
6. The land drain pipe must be perforated pvc wrapped with 1" clean gravel and fabric liner on all 4 sides of gravel (includes all 6" laterals).

7. All handicap ramps to meet APWA Plan 235.1 Example B Truncated Dome Gray in Color.
8. All fire hydrants shall meet Water District Standards.

Approved for Construction
Weber County Engineer
Date: _____

Developer:
Pat Burns
Lync Construction
801-710-2234

The Geotechnical Report provided by: CMT Engineering Laboratories (Project No. 10878, Dated March 7, 2018) has critical information in regards to this project and must be followed.

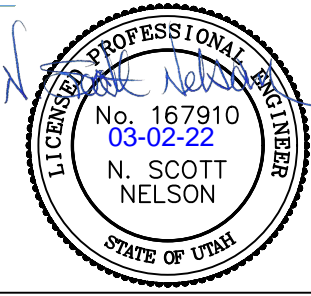

Project: **IMPROVEMENTS STAGECOACH ESTATES WEBER COUNTY, UTAH**

Title: **1800 SOUTH STREET PLAN & PROFILE: STA 307+00 - 310+50**

Date: 2 MARCH 2022

Sheet 22 of 37

Prepared By: **Summers Engineering Collective**
- Jen Summers -
Summers.eng.collective@gmail.com

#	Date:	Revision:

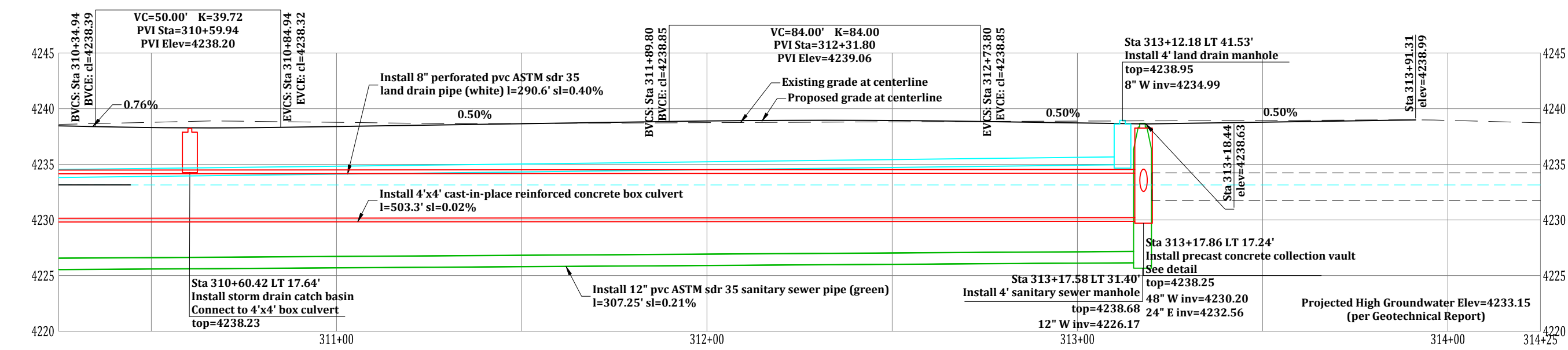
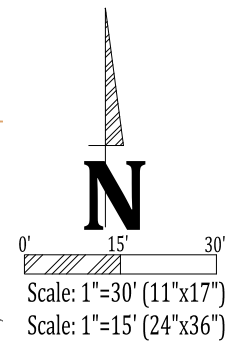
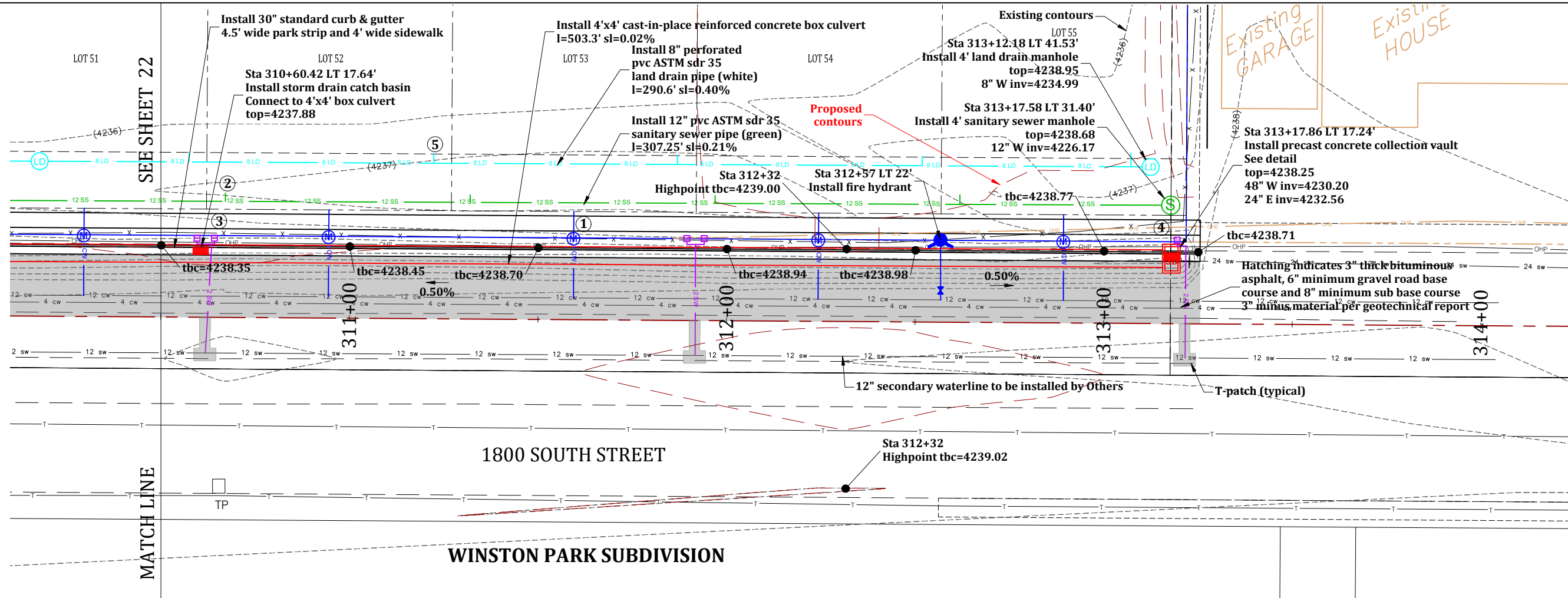

CONSTRUCTION NOTES:

- Construct 1" copper water lateral and meter box (typical).
- Install 4" pvc sanitary sewer lateral (typical) sl=2% minimum.
- Install double service meter (typical). Install 1-1/2" CTS poly secondary water lateral.
- Install service meter (typical). Install 1-1/2" CTS poly secondary water lateral.
- Install 6" pvc Class 150 land drain lateral sl=1% minimum.
- The land drain pipe must be perforated pvc wrapped with 1" clean gravel and fabric liner on all 4 sides of gravel (includes all 6" laterals).
- All handicap ramps to meet APWA Plan 235.1 Example B Truncated Dome Gray in Color.
- All fire hydrants shall meet Water District Standards.

Approved for Construction
Weber County Engineer
Date: _____

Developer:
Pat Burns
Lync Construction
801-710-2234

The Geotechnical Report provided by: CMT Engineering Laboratories (Project No. 10878, Dated March 7, 2018) has critical information in regards to this project and must be followed.

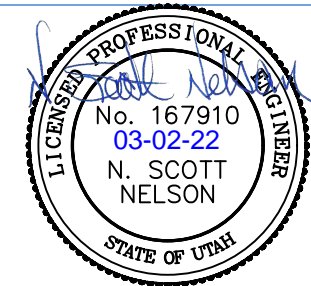

Project: **IMPROVEMENTS STAGECOACH ESTATES WEBER COUNTY, UTAH**

Title: **1800 SOUTH STREET PLAN & PROFILE: STA 310+50 - 314+00**

Date: 2 MARCH 2022

Prepared By: **Summers Engineering Collective**
- Jen Summers -
Summers.eng.collective@gmail.com

#	Date:	Revision:

Sheet 23 of 37

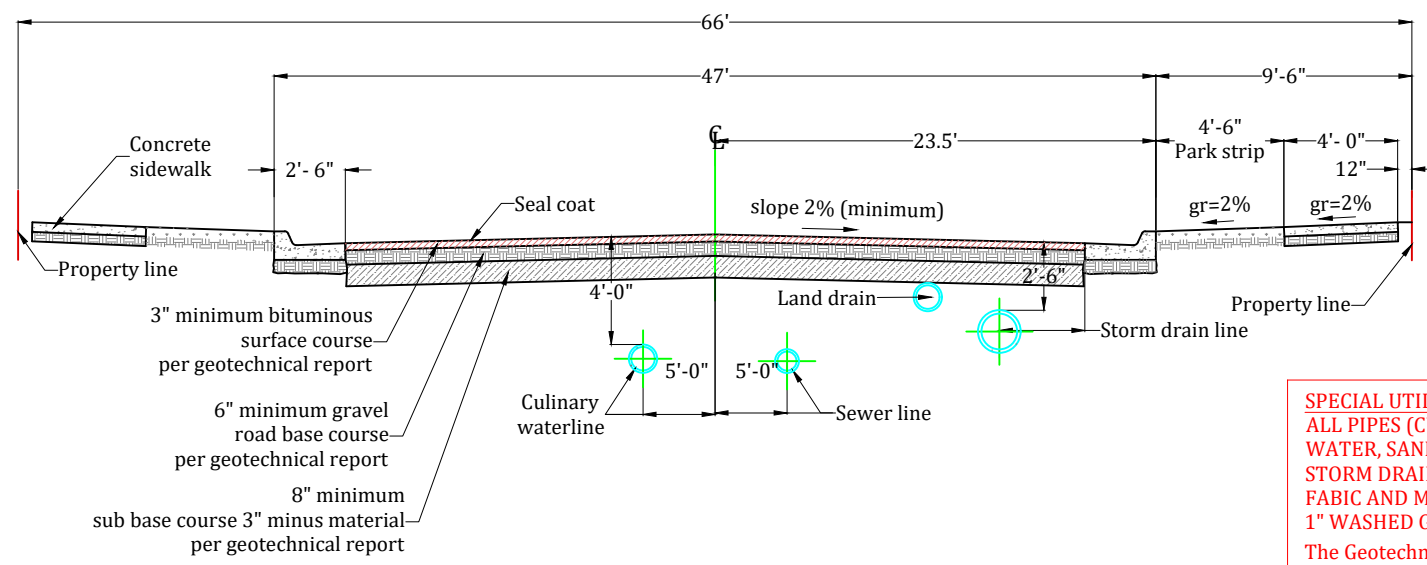

**3875 WEST STREET
ROADWAY SECTION**
SCALE: NONE

SPECIAL UTILITY NOTE:
ALL PIPES (CULINARY WATER, SECONDARY WATER, SANITARY SEWER, LAND DRAIN AND STORM DRAIN) MUST BE WRAPPED IN MIRAFI FABRIC AND MUST HAVE ALL SIDES 6" THICK OF 1" WASHED GRAVEL

The Geotechnical Report provided by: CMT Engineering Laboratories (Project No. 10878, Dated March 7, 2018) has critical information in regards to this project and must be followed.

- NOTES:**
1. Maximum difference in elevation between curb on opposite side of street shall not exceed 1'-0".
 2. Pavement thickness shall be considered as minimum and may be increased by the Engineer or the geotechnical report when the subgrade c.b.r. is less than 10 or when a greater depth is necessary to provide sufficient stability.
 3. Minor and major arterial streets shall be constructed with a 12" untreated base course and 3" bituminous surface course as required per geotechnical report.
 4. Minimum storm drain line size is 15" diameter.
 5. Minimum water line size is 8" diameter.
 6. Minimum sanitary sewer line size is 8" diameter.
 7. Contractor shall not install contaminated /recycled roadbase.

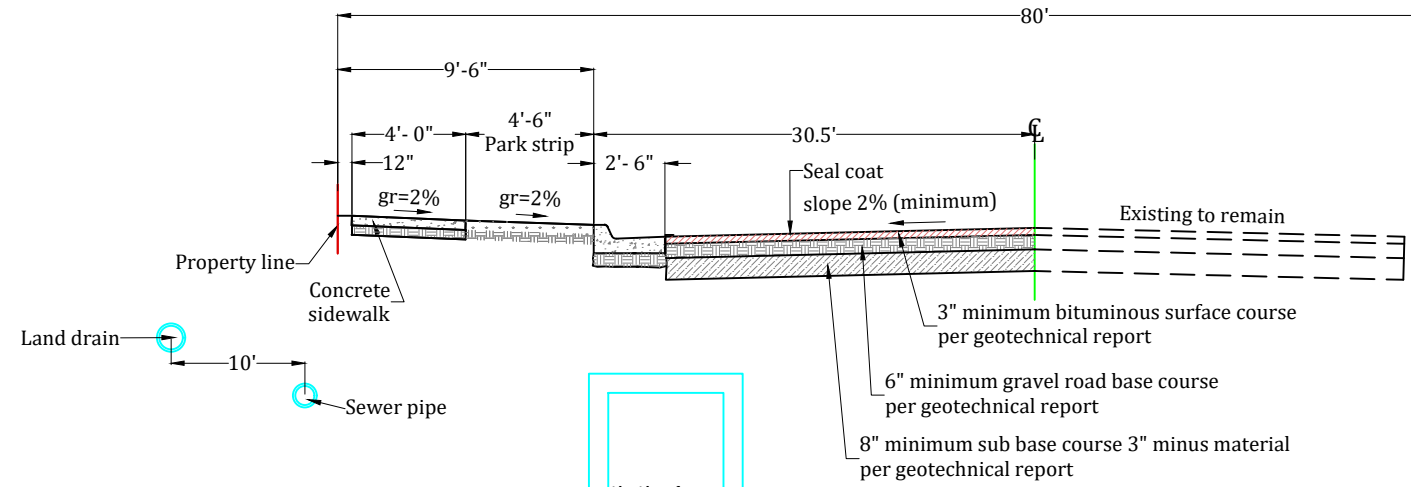

**1800 SOUTH STREET
ROADWAY SECTION**
SCALE: NONE

SPECIAL UTILITY NOTE:
ALL PIPES (CULINARY WATER, SECONDARY WATER, SANITARY SEWER, LAND DRAIN AND STORM DRAIN) MUST BE WRAPPED IN MIRAFI FABRIC AND MUST HAVE ALL SIDES 6" THICK OF 1" WASHED GRAVEL

The Geotechnical Report provided by: CMT Engineering Laboratories (Project No. 10878, Dated March 7, 2018) has critical information in regards to this project and must be followed.

- NOTES:**
1. Maximum difference in elevation between curb on opposite side of street shall not exceed 1'-0".
 2. Pavement thickness shall be considered as minimum and may be increased by the Engineer or the geotechnical report when the subgrade c.b.r. is less than 10 or when a greater depth is necessary to provide sufficient stability.
 3. Minor and major arterial streets shall be constructed with a 12" untreated base course and 3" bituminous surface course as required per geotechnical report.
 4. Minimum storm drain line size is 15" diameter.
 5. Minimum water line size is 8" diameter.
 6. Minimum sanitary sewer line size is 8" diameter.
 7. Contractor shall not install contaminated /recycled roadbase.

Developer:
Pat Burns
Lync Construction
801-710-2234

Approved for Construction

Weber County Engineer
Date: _____

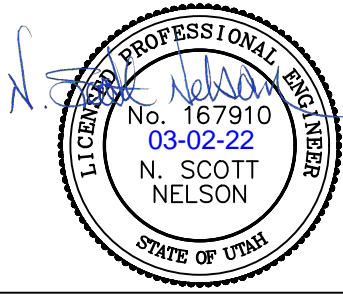

Project: **IMPROVEMENTS
STAGECOACH ESTATES
WEBER COUNTY, UTAH**

Title: **DETAILS: ROADS**

Date: **2 MARCH 2022**

Prepared By:
Summers Engineering Collective
- Jen Summers -
Summers.eng.collective@gmail.com

#	Date:	Revision:

Sheet 24 of 37

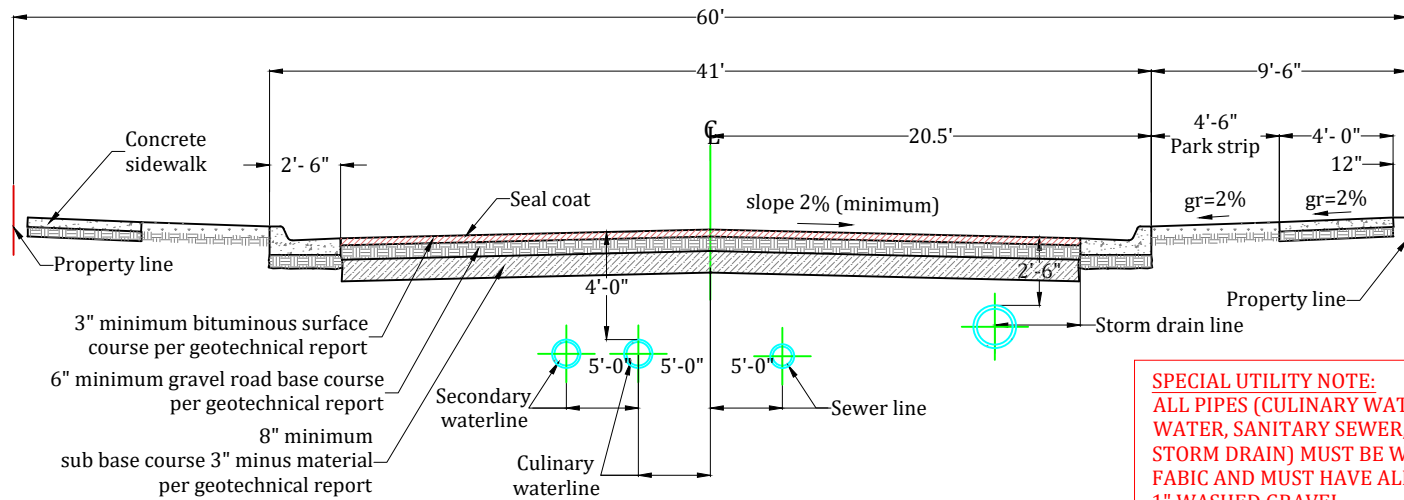

**1700 SOUTH STREET
(STA 100+00 - 102+14)
ROADWAY SECTION**
SCALE: NONE

SPECIAL UTILITY NOTE:
ALL PIPES (CULINARY WATER, SECONDARY WATER, SANITARY SEWER, LAND DRAIN AND STORM DRAIN) MUST BE WRAPPED IN MIRAFI FABRIC AND MUST HAVE ALL SIDES 6" THICK OF 1" WASHED GRAVEL
The Geotechnical Report provided by: CMT Engineering Laboratories (Project No. 10878, Dated March 7, 2018) has critical information in regards to this project and must be followed.

NOTES:

1. Maximum difference in elevation between curb on opposite side of street shall not exceed 1'-0".
2. Pavement thickness shall be considered as minimum and may be increased by the Engineer or the geotechnical report when the subgrade c.b.r. is less than 10 or when a greater depth is necessary to provide sufficient stability.
3. Minor and major arterial streets shall be constructed with a 12" untreated base course and 3" bituminous surface course as required per geotechnical report.
4. Minimum storm drain line size is 15" diameter.
5. Minimum water line size is 8" diameter.
6. Minimum sanitary sewer line size is 8" diameter.
7. Contractor shall not install contaminated /recycled roadbase.

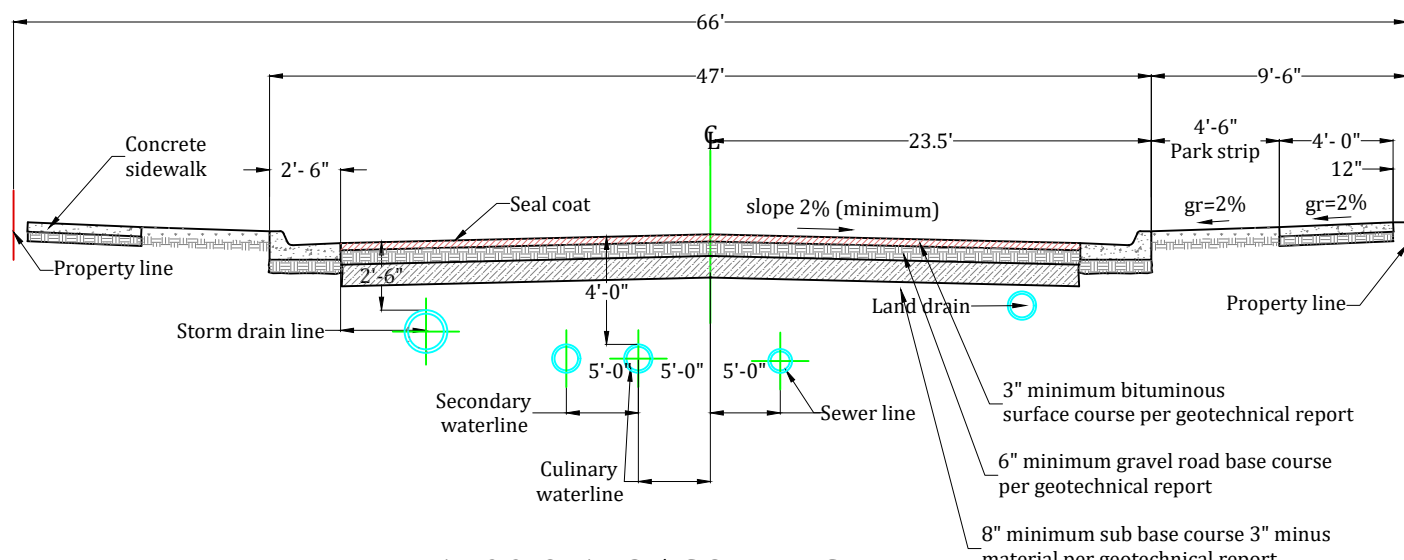

**1700 & 1725 SOUTH STREET
(STA 102+14 - 114+23)
ROADWAY SECTION**
SCALE: NONE

NOTES:

1. Maximum difference in elevation between curb on opposite side of street shall not exceed 1'-0".
2. Pavement thickness shall be considered as minimum and may be increased by the Engineer or the geotechnical report when the subgrade c.b.r. is less than 10 or when a greater depth is necessary to provide sufficient stability.
3. Minor and major arterial streets shall be constructed with a 12" untreated base course and 3" bituminous surface course as required per geotechnical report.
4. Minimum storm drain line size is 15" diameter.
5. Minimum water line size is 8" diameter.
6. Minimum sanitary sewer line size is 8" diameter.
7. Contractor shall not install contaminated /recycled roadbase.

SPECIAL UTILITY NOTE:
ALL PIPES (CULINARY WATER, SECONDARY WATER, SANITARY SEWER, LAND DRAIN AND STORM DRAIN) MUST BE WRAPPED IN MIRAFI FABRIC AND MUST HAVE ALL SIDES 6" THICK OF 1" WASHED GRAVEL
The Geotechnical Report provided by: CMT Engineering Laboratories (Project No. 10878, Dated March 7, 2018) has critical information in regards to this project and must be followed.

Developer:
Pat Burns
Lync Construction
801-710-2234

Approved for Construction
Weber County Engineer
Date: _____

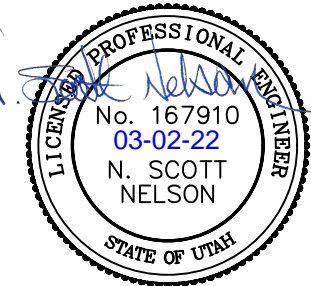

Project: **IMPROVEMENTS
STAGECOACH ESTATES
WEBER COUNTY, UTAH**

Title: **DETAILS: ROADS**

Date: 2 MARCH 2022

Prepared By:
Summers Engineering Collective
- Jen Summers -
Summers.eng.collective@gmail.com

#	Date	Revision

Sheet 25 of 37

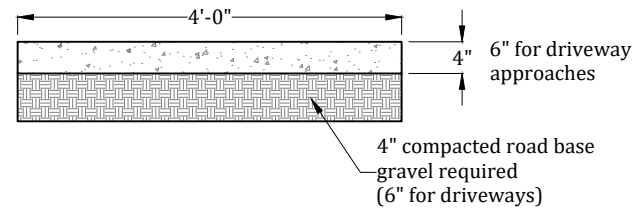

SIDEWALK SECTION

SCALE: NONE

1
-

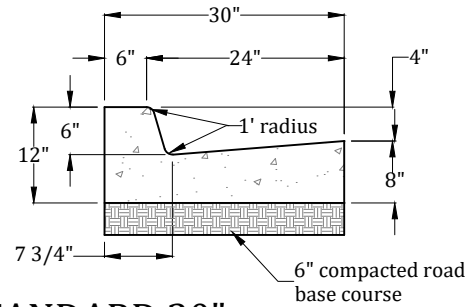

STANDARD 30" CURB & GUTTER

SCALE: NONE

2
-

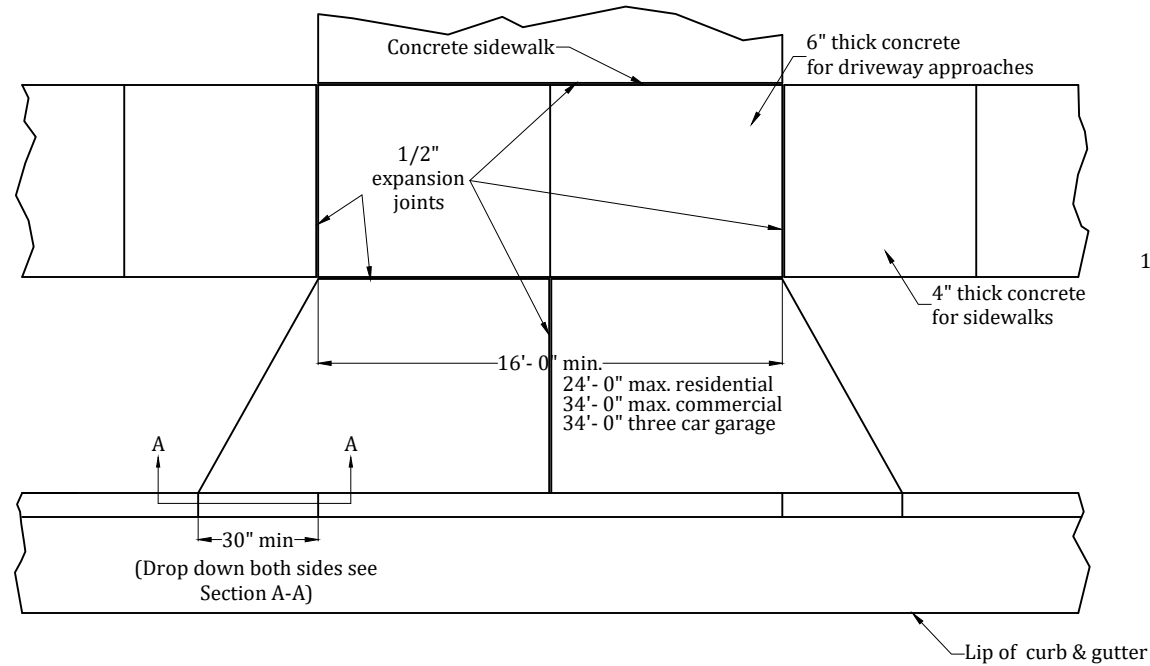

DRIVEWAY APPROACH

SCALE: NONE

3
-

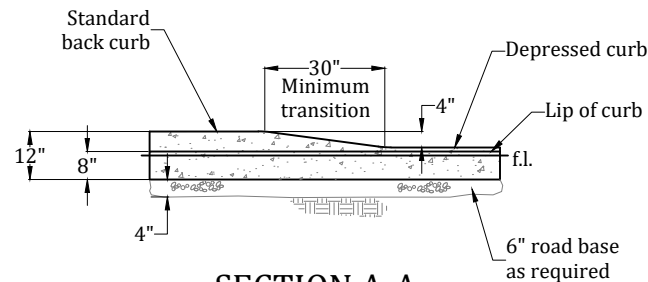

SECTION A-A

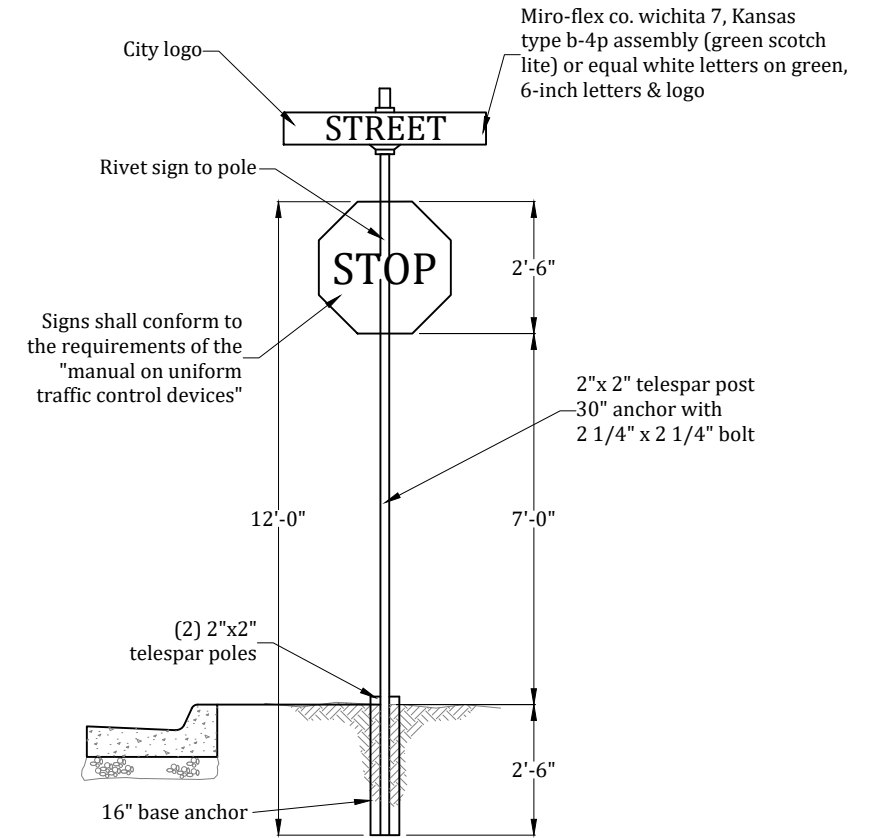

TYPICAL REGULATORY SIGN W/ STREET NUMBER SIGN

SCALE: NONE

4
-

Developer:
Pat Burns
Lync Construction
801-710-2234

Approved for Construction
Weber County Engineer
Date: _____

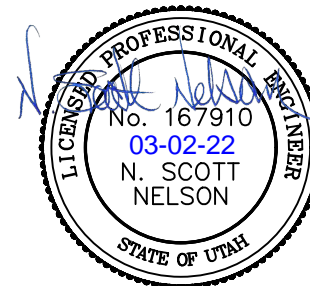

Project: **IMPROVEMENTS
STAGECOACH ESTATES
WEBER COUNTY, UTAH**

Prepared By:
Summers Engineering Collective
- Jen Summers -
Summers.eng.collective@gmail.com

Title: **DETAILS: ROADS**

#	Date:	Revision:

Date:
2 MARCH 2022

Sheet 26 of 37

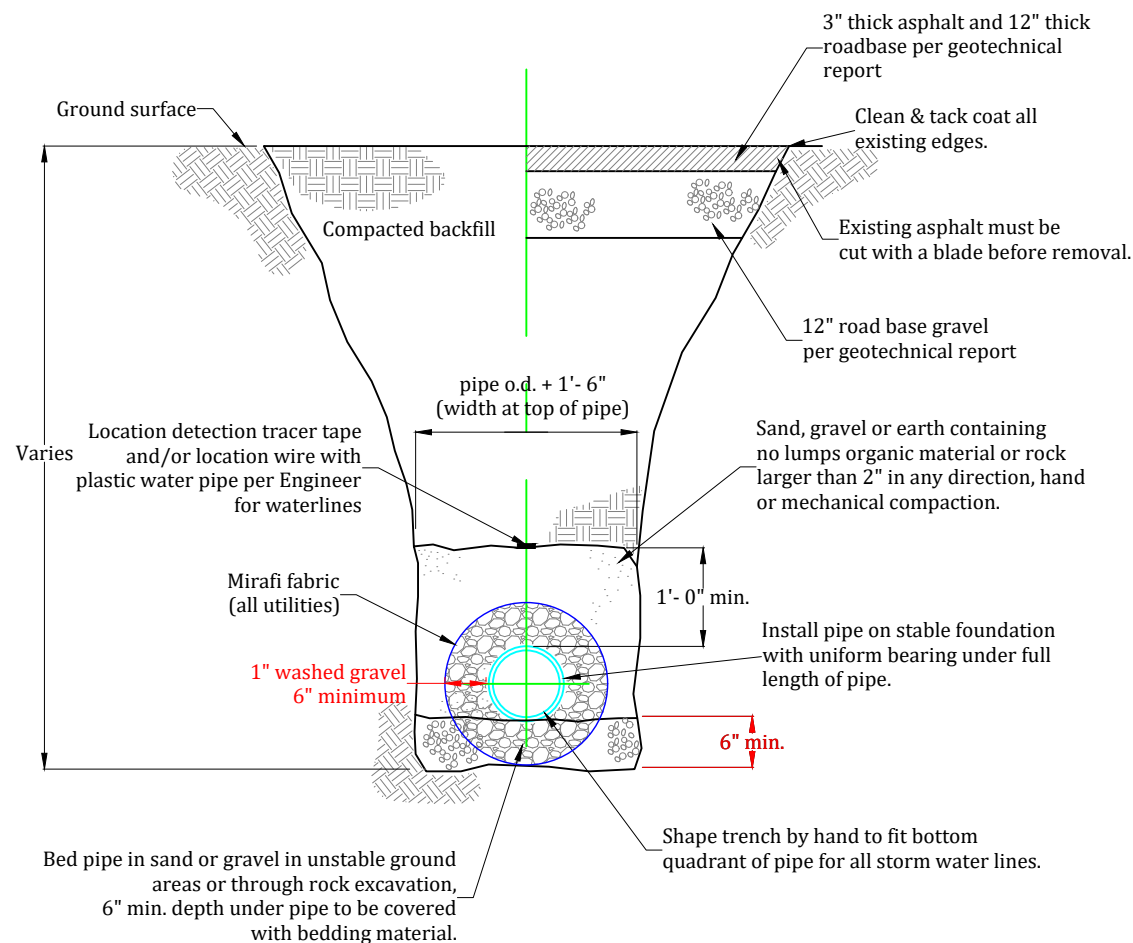

STANDARD TRENCH CROSS-SECTION

SCALE: NONE

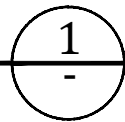

All utility trenching within road right-of-ways which are 66' wide or wider shall have backfill material per geotechnical report.

Safe bearing loads	
Soil type	Safe bearing load (lb/ft ²)
Sand	1000
Sand & gravel	1500
Sand & gravel cemented with clay	2000
Shale	5000

Thrust block area against trench wall (square feet) = Thrust on / fitting / Safe bearing load of soil

SPECIAL UTILITY NOTE:
 ALL PIPES (CULINARY WATER, SECONDARY WATER, SANITARY SEWER, LAND DRAIN AND STORM DRAIN) MUST BE WRAPPED IN MIRAFI FABRIC AND MUST HAVE ALL SIDES 6" THICK OF 1" WASHED GRAVEL
 The Geotechnical Report provided by: CMT Engineering Laboratories (Project No. 10878, Dated March 7, 2018) has critical information in regards to this project and must be followed.

SANITARY SEWER TRENCH NOTES:

- The Contractor shall be responsible for meeting all current OSHA and UOSH requirements for trench safety.
- Contractor shall locate all underground utilities before laying pipe within 200' of said utilities which may be exposed, damaged or crossed as shown on the drawings or as "blue staked" the Contractor will make arrangements with the utility company to move the utility if necessary or obtain permission from the project engineer to modify grade of pipeline in order to go around utilities.
- The Contractor shall determine the actual location of existing service connections and utilities and take the necessary steps to avoid them. The Contractor is responsible for any damage occurring during construction.
- Testing: All new sanitary sewers to be cleaned, "videotaped", and necessary repairs made before acceptance. All lines shall be pressure tested to 3.5 psi min. for 5 minutes. A mandrel or ball can be used to verify deformation of a pipe as determined from the videotape unless specified otherwise.
- All measurements are in English units.
- All sewer lines to be installed in roadway.
- All sewer lines to be installed at a minimum 10' distance from any water lines.
- All sewer lines to be installed with a minimum of 4' cover to the top of the pipe.

STORM DRAIN TRENCH NOTES:

- The Contractor shall be responsible for meeting all current OSHA and UOSH requirements for trench safety.
- Contractor shall locate all underground utilities before laying pipe within 50' of said utilities which may be exposed, damaged or crossed as shown on the drawings or as "blue staked" the contractor will make arrangements with the utility company to move the utility if necessary or obtain permission from the Project Engineer to modify grade of pipeline in order to go around utilities.
- Testing: All new storm drain systems to be cleaned, "videotaped", and necessary repairs made before acceptance. All lines shall be pressure tested to 3.5 psi (min.) for 5 minutes. A mandrel or ball can be used to verify deformation of a pipe as determined from the videotape.
- All storm drain lines to be installed in roadway or under curb and gutter with approval by Weber County engineer.
- Minimum pipe size for storm drain pipe is 15" diameter and must be concrete.

CULINARY WATER TRENCH NOTES:

- Waterlines 12 inches and larger shall be ductile iron Class-51. Waterlines 10-inches and smaller shall be PVC C-900 DR-18 or ductile iron Class-51.
- All waterlines shall be 8" minimum.
- Valves larger than 12 inches shall be butterfly valves with boxes.
- Ductile iron pipe and fittings shall be wrapped with polyethylene and have cathodic protection where required.
- Whenever possible "hot tap" connections required. Hot tap valve to be supported during connection. Contractor to notify City 24 hours in advance of making connection.
- Contractor shall contact property owners 24 hours in advance with written notice for shutting off water.
- Pipe zone shall be backfilled with sand or material as approved by Weber County Engineer.
- Concrete collars shall be placed around all valves.
- The following tests must be passed before the waterline is connected for service:
 - Pressure Test - Must keep a minimum of 200 PSI for 2 hours
 - Chlorination Test - Must keep a minimum of 30 PPM for 24 hours.
 - Clear Water Test
 - Bacteria Test - A minimum of 2 tests are required.
- All mechanical joint restraint (e.g. megalug) connections, flange fittings and all other fittings using connection bolts must be furnished and installed with bluebolts.
- All sewer lines to be installed with a minimum of 4' cover to the top of the pipe.

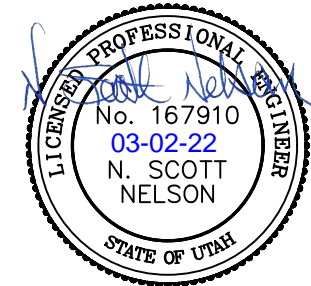

Project:	IMPROVEMENTS STAGECOACH ESTATES WEBER COUNTY, UTAH	Prepared By:	Summers Engineering Collective - Jen Summers - Summers.eng.collective@gmail.com
Title:	DETAILS: TRENCHING	#	Date: Revision:
Date:	2 MARCH 2022		
	Sheet 27 of 37		

Developer:
 Pat Burns
 Lync Construction
 801-710-2234

Approved for Construction

 Weber County Engineer
 Date: _____

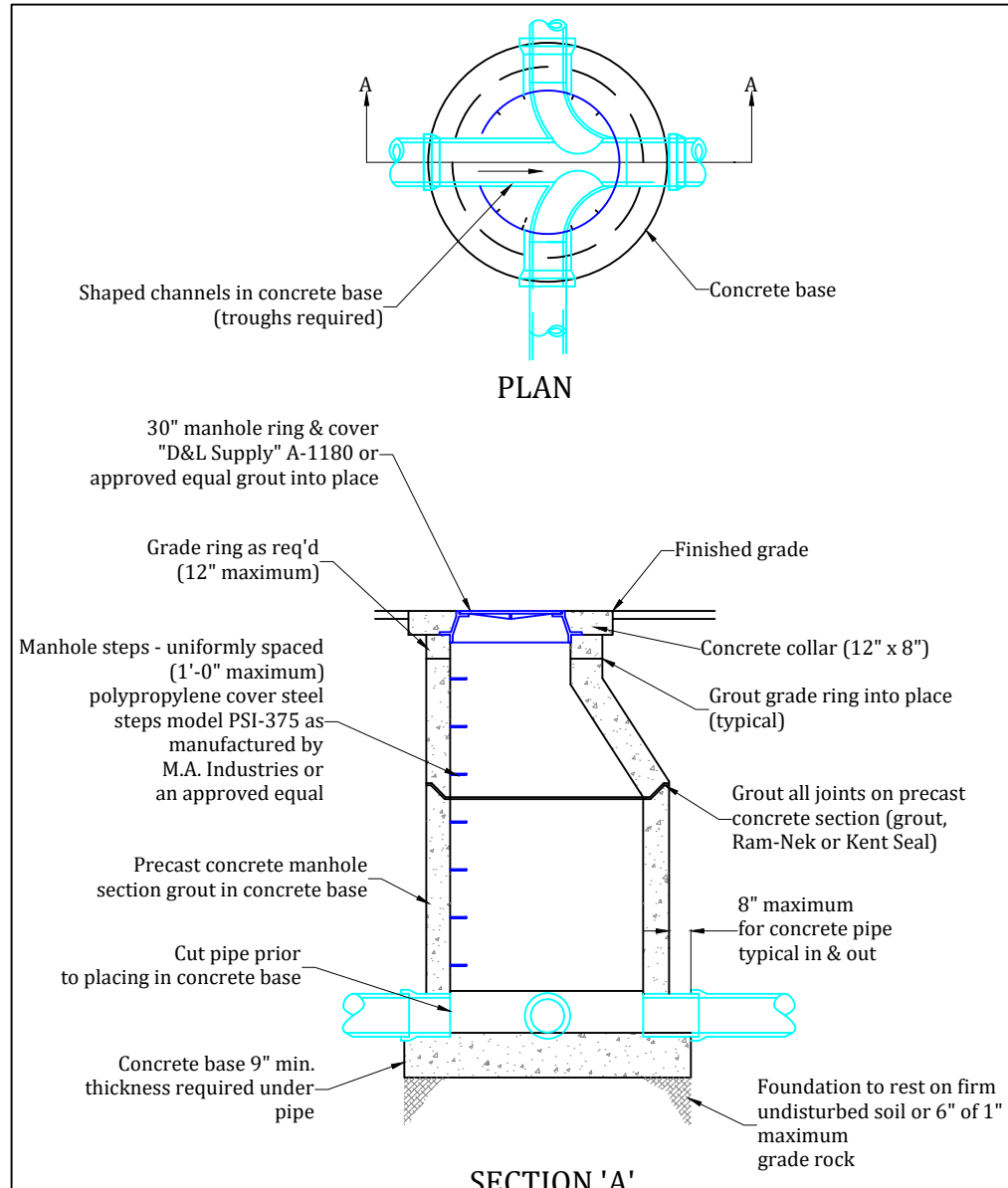

NOTES:

1. Cast in place manhole shown. A precast reinforced manhole is acceptable.
2. Expansion water tight boot to be installed for pipe connections with all precast reinforced manholes.

STANDARD SANITARY SEWER MANHOLE
SCALE: NONE

Developer:
Pat Burns
Lync Construction
801-710-2234

Approved for Construction
Weber County Engineer
Date: _____

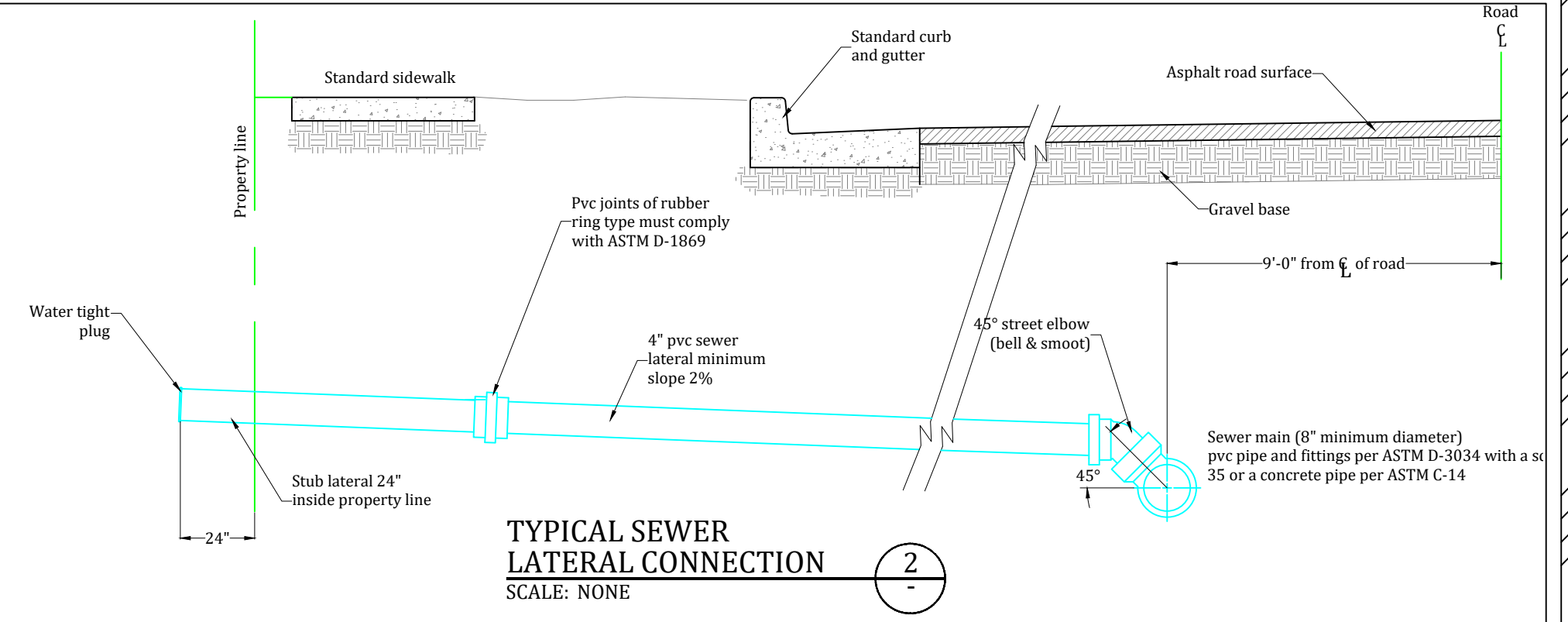

TYPICAL SEWER LATERAL CONNECTION
SCALE: NONE

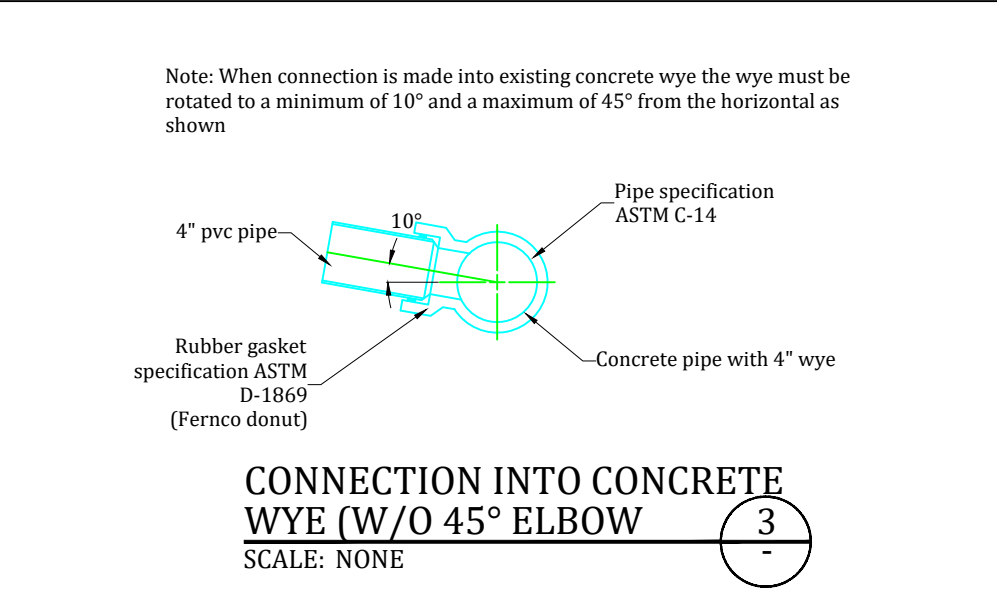

CONNECTION INTO CONCRETE WYE (W/O 45° ELBOW)
SCALE: NONE

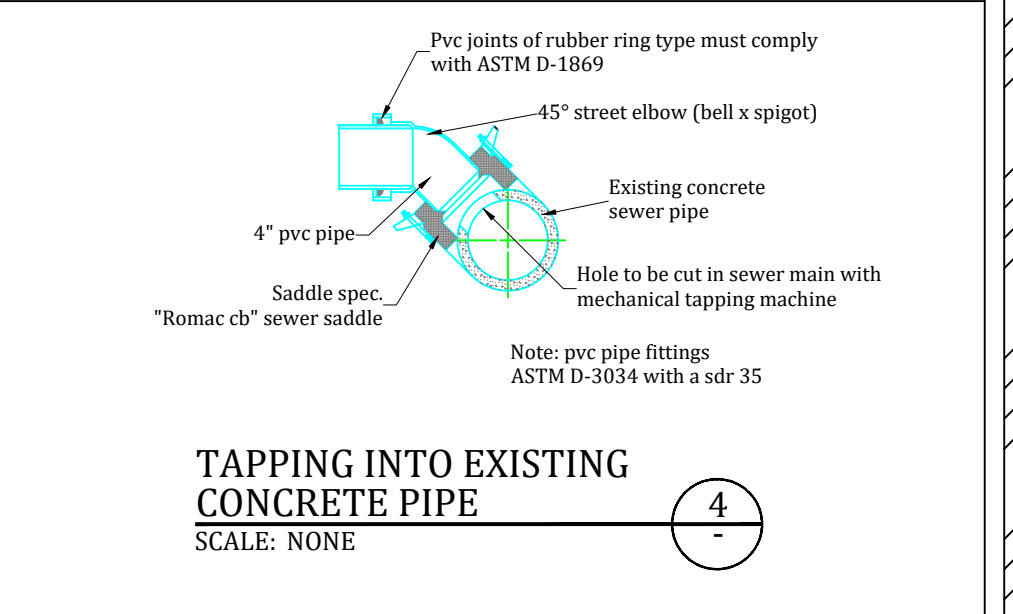

TAPPING INTO EXISTING CONCRETE PIPE
SCALE: NONE

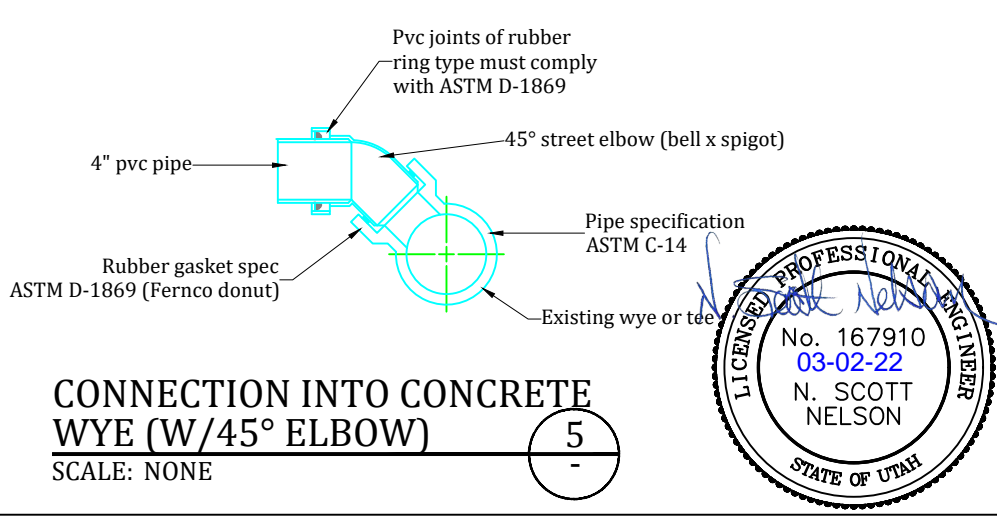

CONNECTION INTO CONCRETE WYE (W/45° ELBOW)
SCALE: NONE

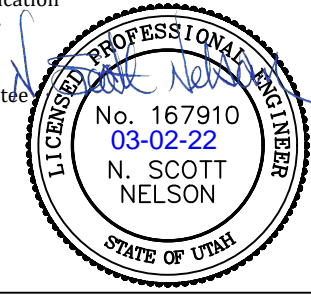

Project: **IMPROVEMENTS STAGECOACH ESTATES WEBER COUNTY, UTAH**

Title: **DETAILS: CULINARY WATER**

Date: 2 MARCH 2022

Prepared By: **Summers Engineering Collective**
- Jen Summers -
Summers.eng.collective@gmail.com

#	Date:	Revision:

Sheet 28 of 37

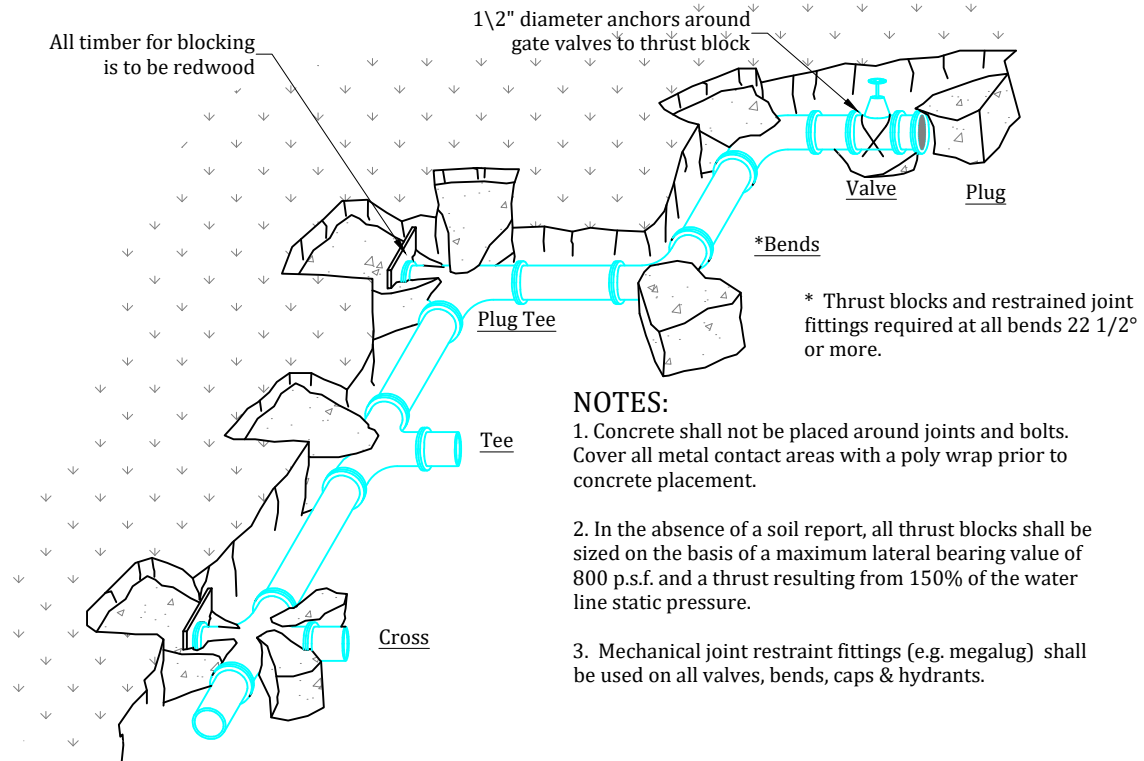

NOTES:

1. Concrete shall not be placed around joints and bolts. Cover all metal contact areas with a poly wrap prior to concrete placement.
2. In the absence of a soil report, all thrust blocks shall be sized on the basis of a maximum lateral bearing value of 800 p.s.f. and a thrust resulting from 150% of the water line static pressure.
3. Mechanical joint restraint fittings (e.g. megalug) shall be used on all valves, bends, caps & hydrants.

CONCRETE THRUST BLOCK DETAILS
SCALE: NONE

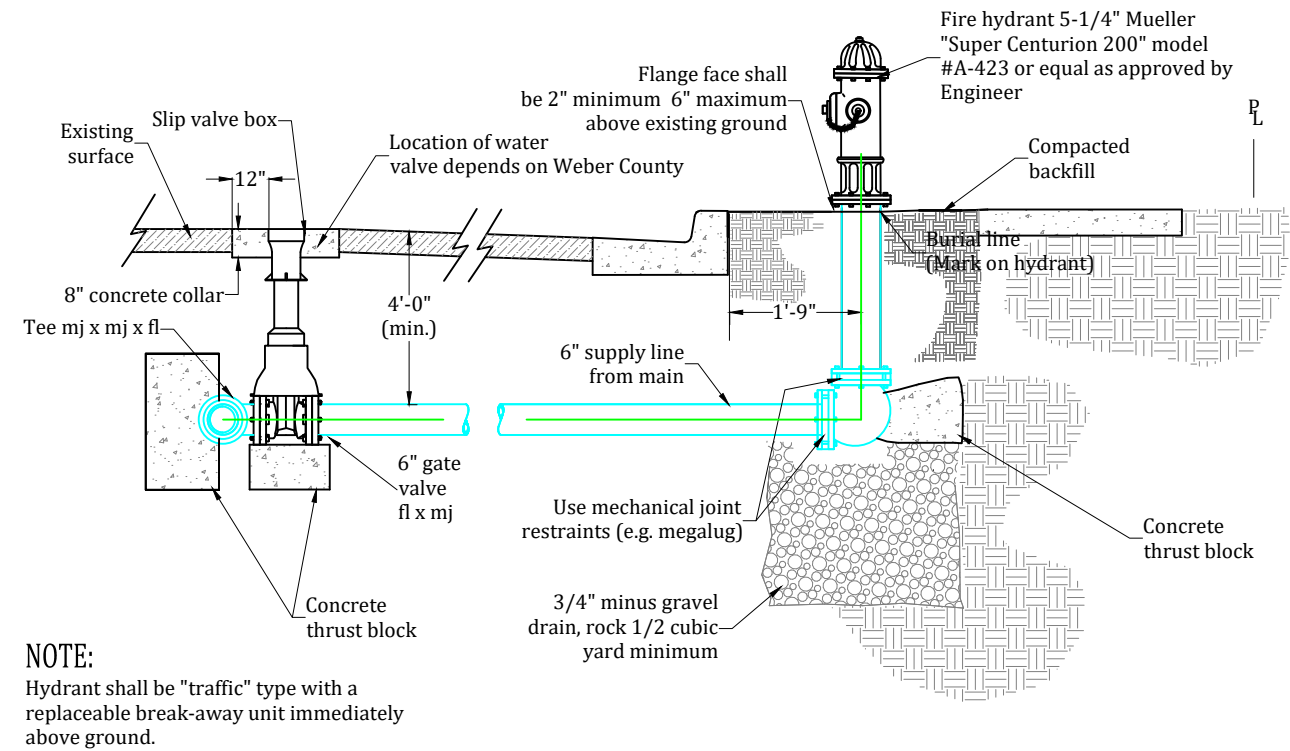

TYPICAL FIRE HYDRANT CONNECTION
SCALE: NONE

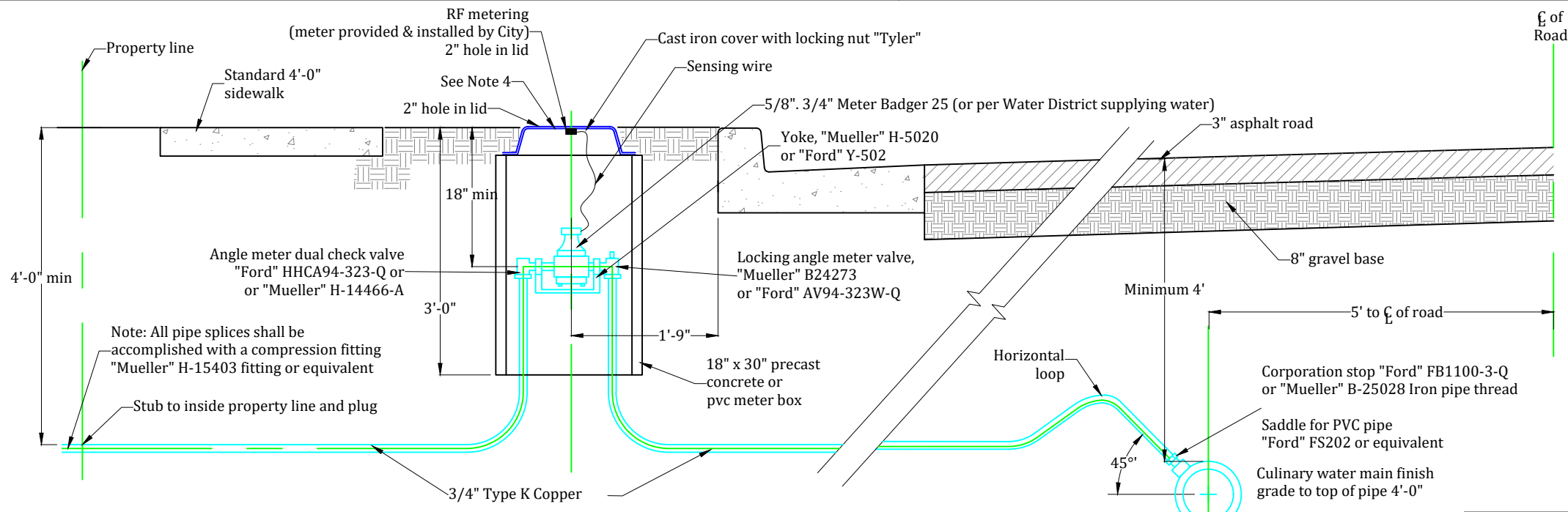

NOTES:

1. ALL MATERIALS SHALL CONFORM TO WATER DISTRICT SUPPLYING CULINARY WATER.
2. Water service pipes to be compacted per compaction trenches standards.
3. All expansion connections to be "Mueller" H-14234 or "Ford" EC-23.
4. This detail shows a typical water connection for a 3/4" meter.
5. Lid to match grade and slope of park strip where possible. If park strip has varying contours, match existing ground from sidewalk to curb & gutter as directed by the County Engineer.

TYPICAL WATER CONNECTION
SCALE: NONE



Developer:
Pat Burns
Lync Construction
801-710-2234

Approved for Construction
Weber County Engineer
Date: _____

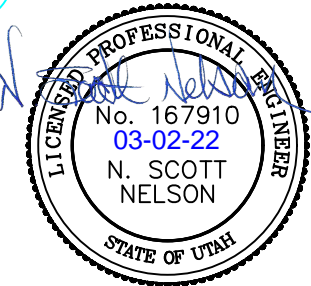

Project: **IMPROVEMENTS STAGECOACH ESTATES WEBER COUNTY, UTAH**

Title: **DETAILS: CULINARY WATER**

Date: 2 MARCH 2022

Sheet 29 of 37

Prepared By: Summers Engineering Collective - Jen Summers - Summers.eng.collective@gmail.com		
#	Date:	Revision:

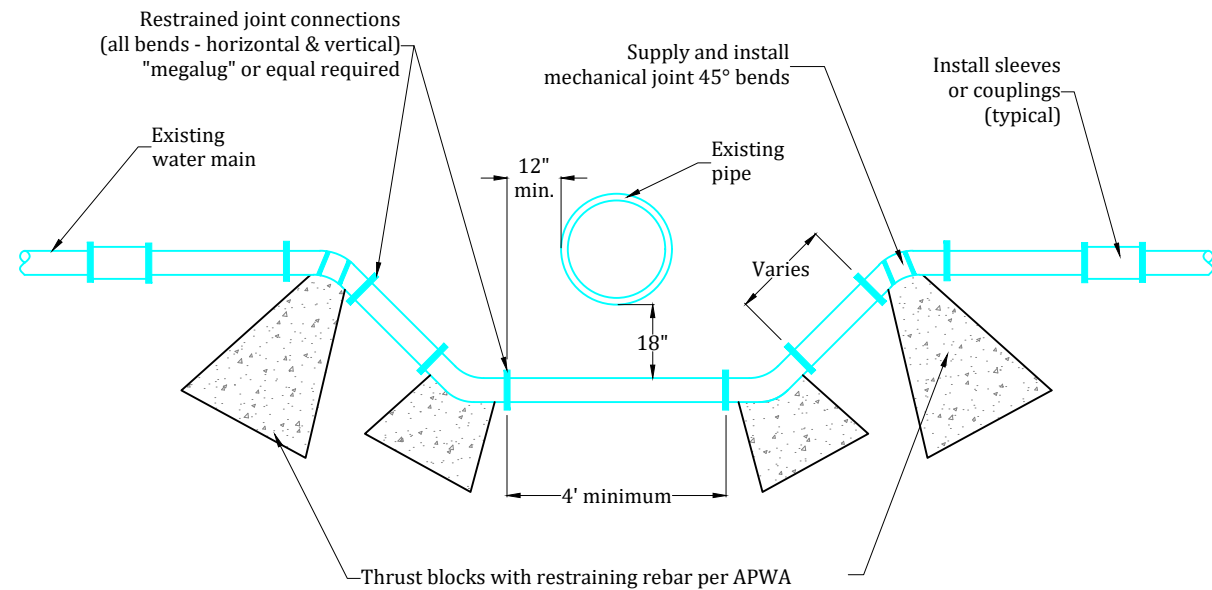

NOTE:
All County residents or commercial water users to be given 24 hour written notice before looping or shutting down any waterline.

**TYPICAL
WATER LOOP**
SCALE: NONE

1

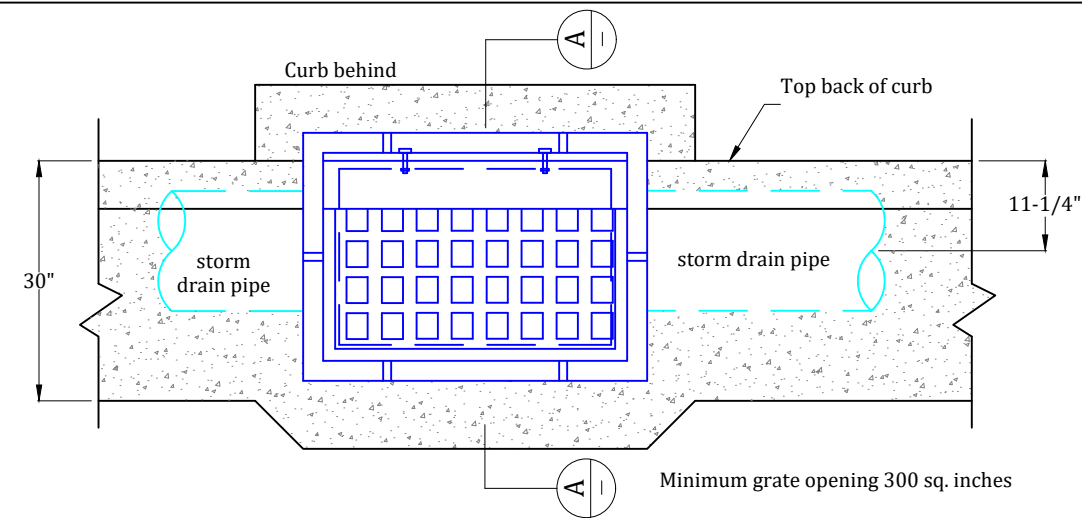

- NOTES:**
1. All reinforcement shall be #4 deformed steel, grade 60.
 2. All reinforcement shall be placed at 9" o.c. each way in the floor and the walls.
 3. The adjustable curb box inlet grate shall be bicycle safe. D&L Supply I-3517 or acceptable equal.
 4. All pipes in the box shall be cut with the interior of the box and grouted smooth.
 5. Rebar shall have 2" clear on earth side of structure.

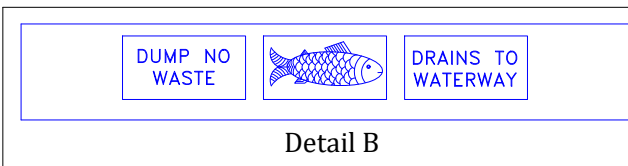
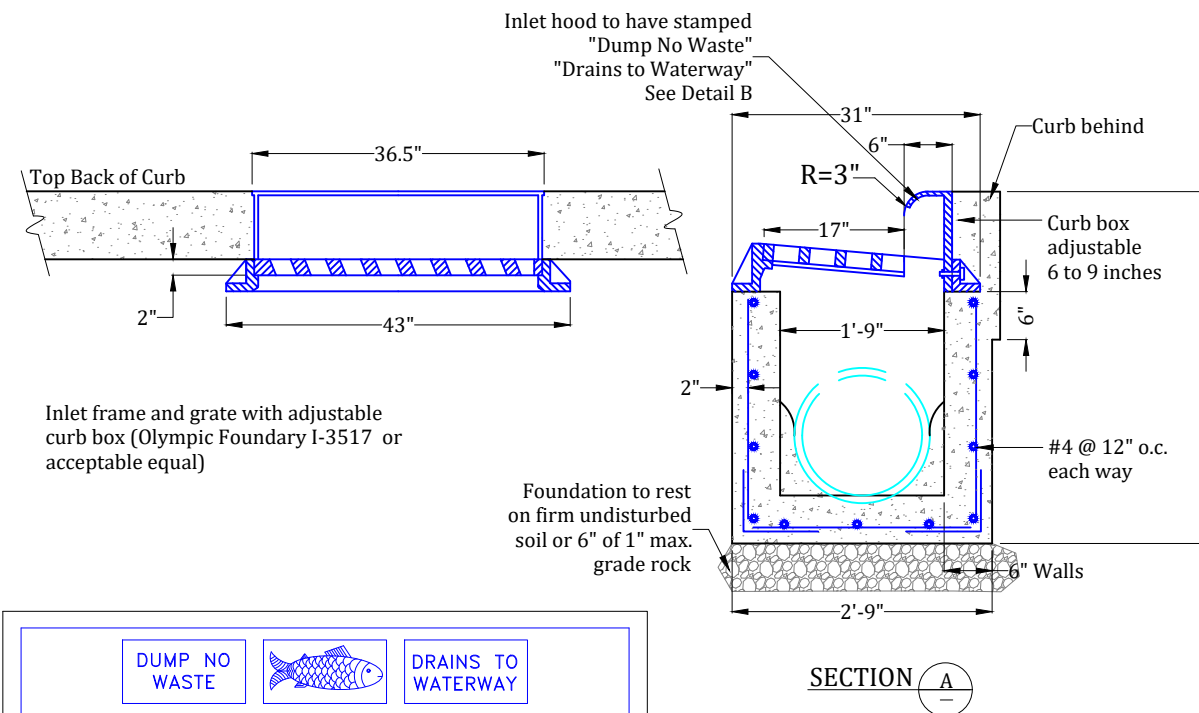

**STANDARD STORM DRAIN
HOODED CATCH BASIN**
SCALE: NONE

2

Developer:
Pat Burns
Lync Construction
801-710-2234

Approved for Construction
Weber County Engineer
Date: _____

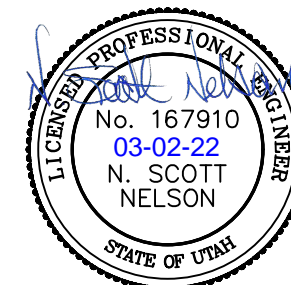

Project: **IMPROVEMENTS
STAGECOACH ESTATES
WEBER COUNTY, UTAH**

Title: **DETAILS:
CULINARY WATER & STORM DRAIN**

Date: 2 MARCH 2022

Sheet 30 of 37

Prepared By:
Summers Engineering Collective
- Jen Summers -
Summers.eng.collective@gmail.com

#	Date:	Revision:

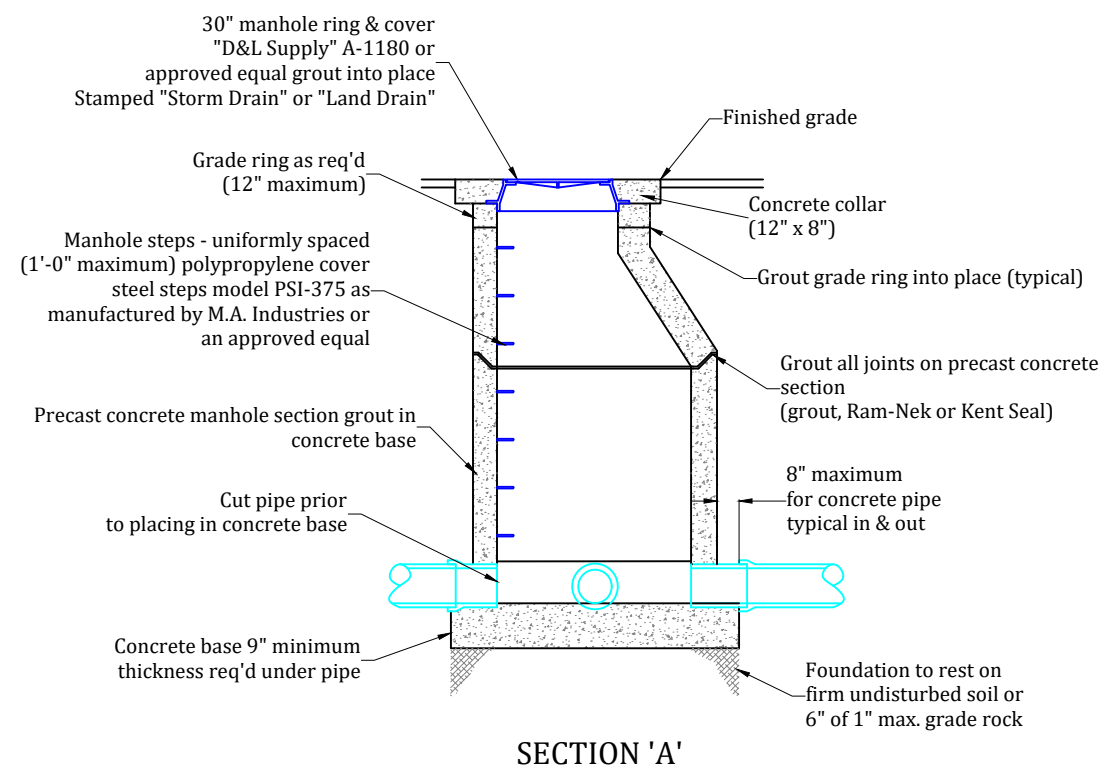
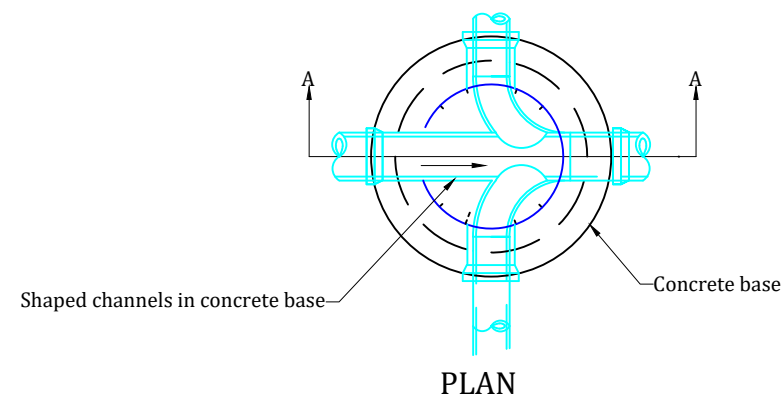

NOTE:
Cast in place manhole shown precast reinforced manhole acceptable.

STANDARD STORM & LAND DRAIN MANHOLE

SCALE: NONE

1

Developer:
Pat Burns
Lync Construction
801-710-2234

Approved for Construction
Weber County Engineer
Date: _____

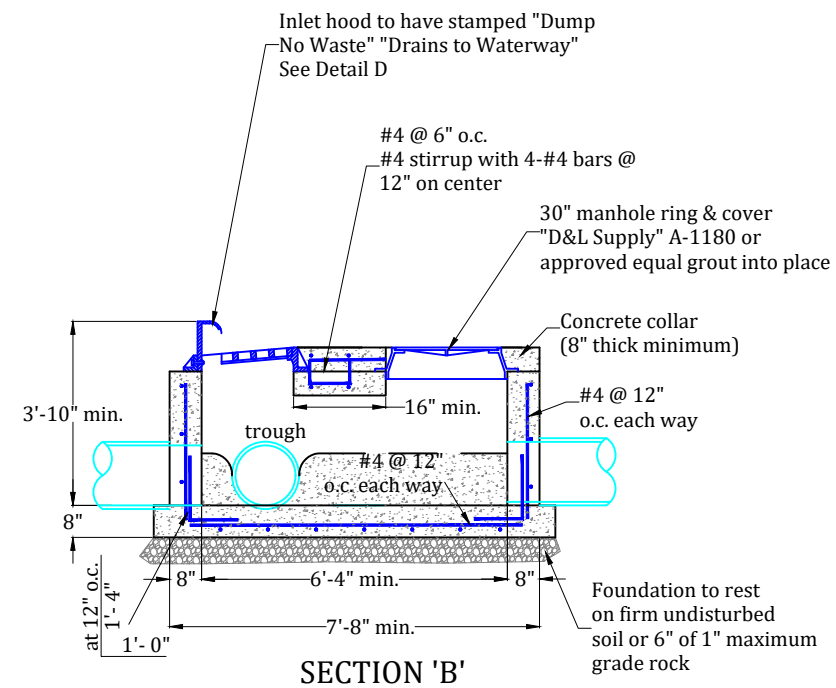

NOTE:
Details here are for "cast-in-place" box.

STANDARD STORM DRAIN COMBINATION BOX

SCALE: NONE

2

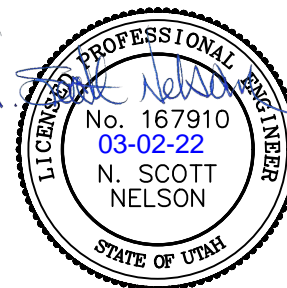
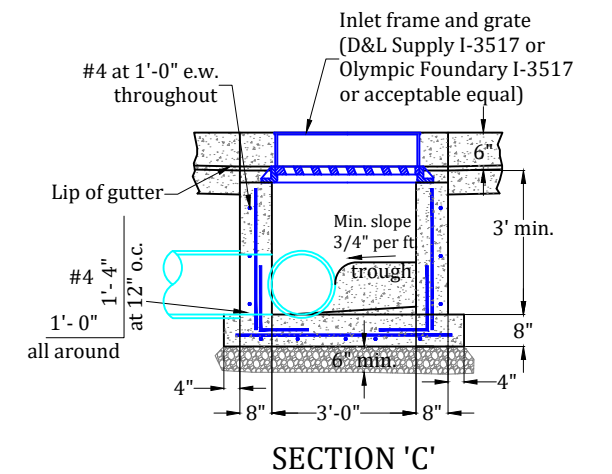
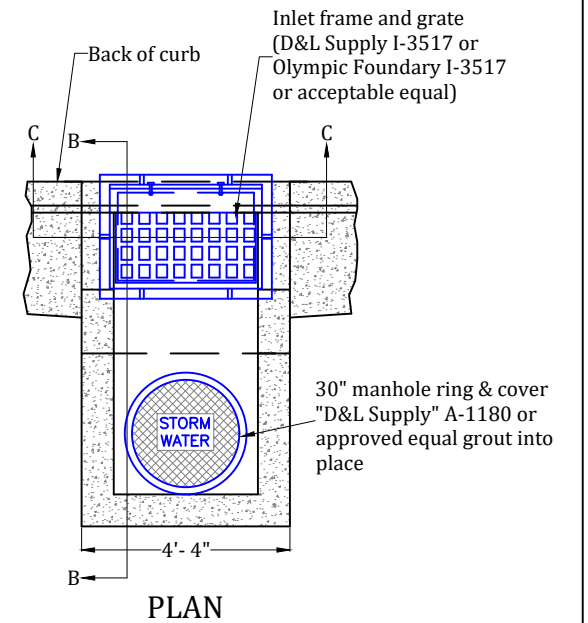

Project: **IMPROVEMENTS STAGECOACH ESTATES WEBER COUNTY, UTAH**

Title: **DETAILS: STORM DRAIN**

Date: 2 MARCH 2022

Sheet 31 of 37

Prepared By: **Summers Engineering Collective**
- Jen Summers -
Summers.eng.collective@gmail.com

#	Date:	Revision:

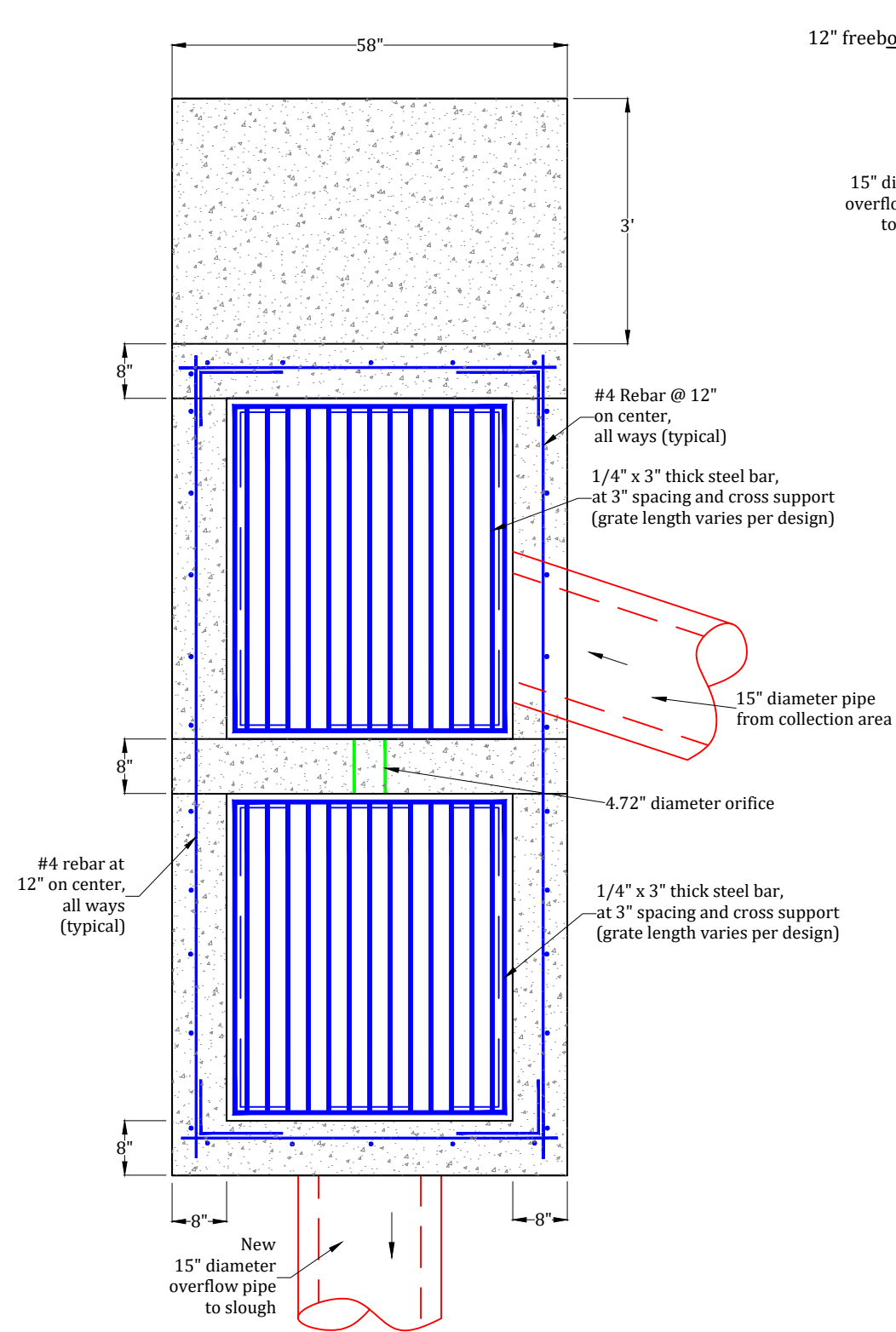

PLAN VIEW

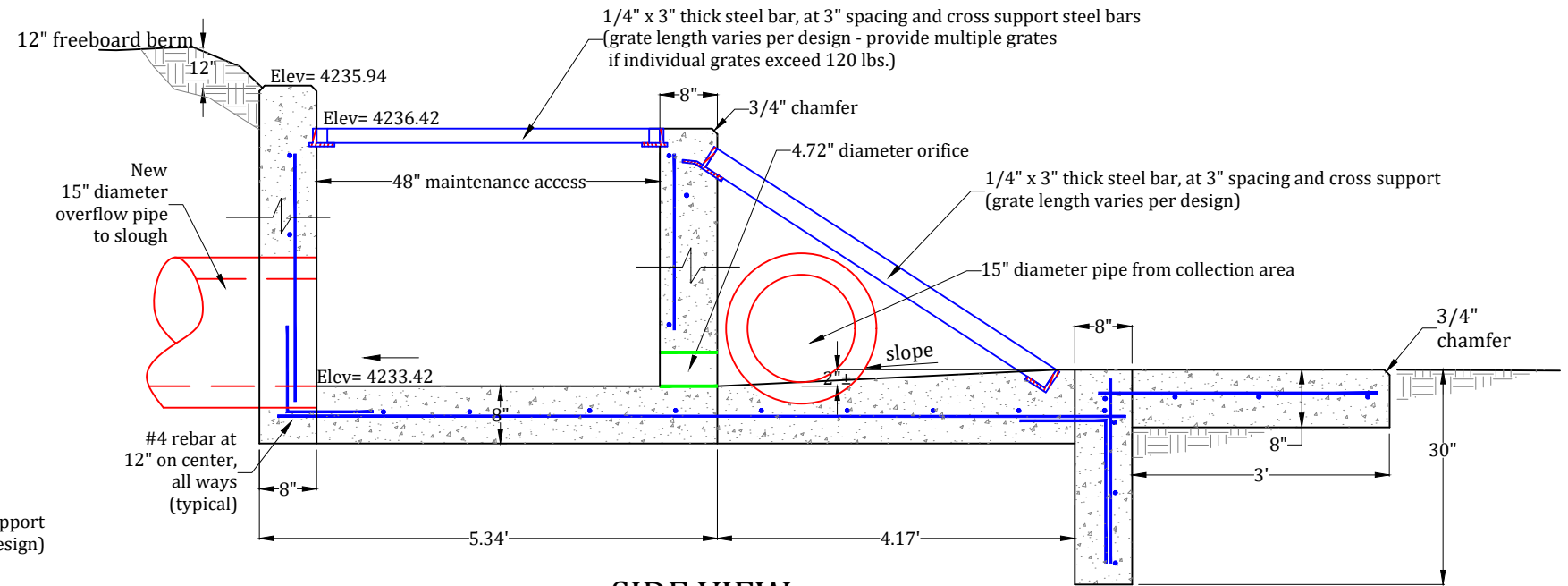

SIDE VIEW

NOTE:
All exposed concrete corners to have a 3/4" chamfered corner

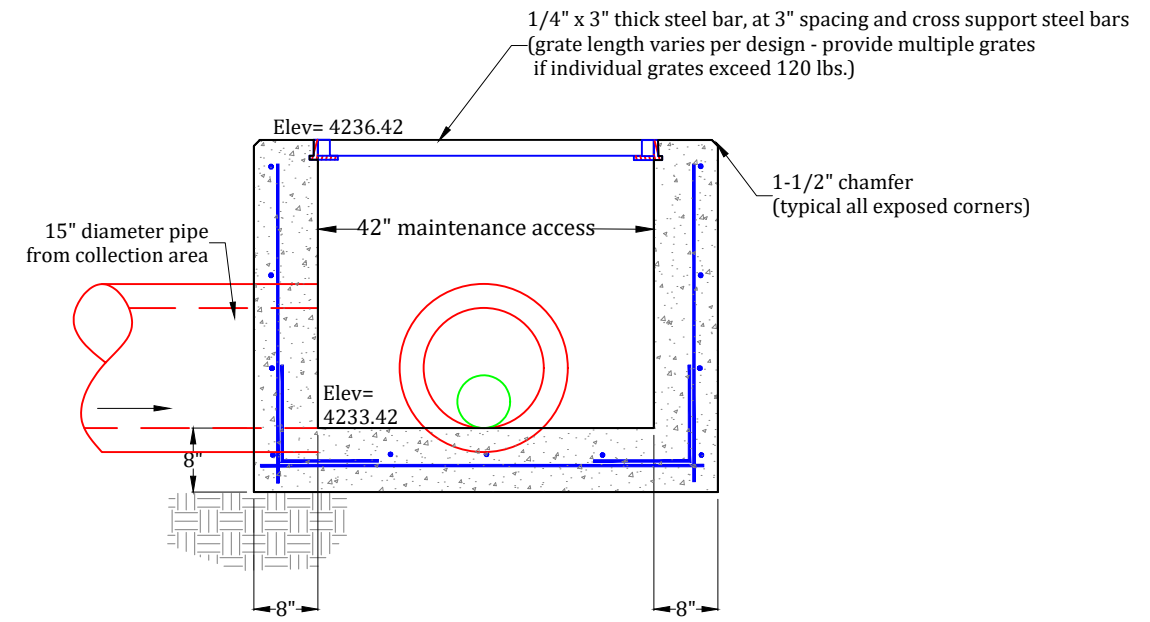

SECTION VIEW

Developer:
Pat Burns
Lync Construction
801-710-2234

Approved for Construction
Weber County Engineer
Date: _____

DETENTION POND #1
INLET/OUTLET STRUCTURE
SCALE: NONE

1



Project: IMPROVEMENTS
STAGECOACH ESTATES
WEBER COUNTY, UTAH
Title: DETAILS: DETENTION POND #1
INLET/OUTLET STRUCTURE
Date: 2 MARCH 2022
Sheet 32 of 37

Prepared By:
Summers Engineering Collective
- Jen Summers -
Summers.eng.collective@gmail.com

#	Date	Revision

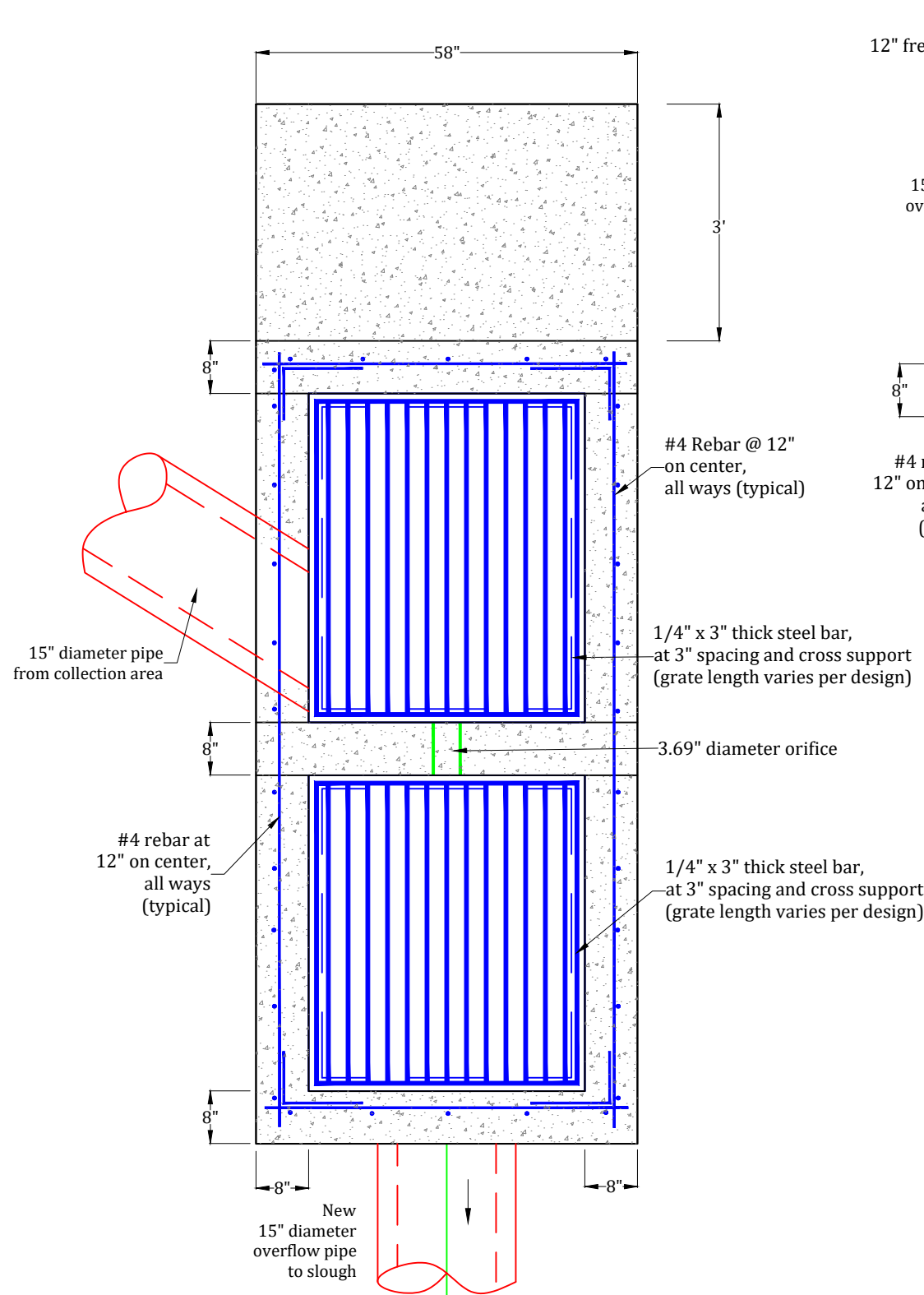

PLAN VIEW

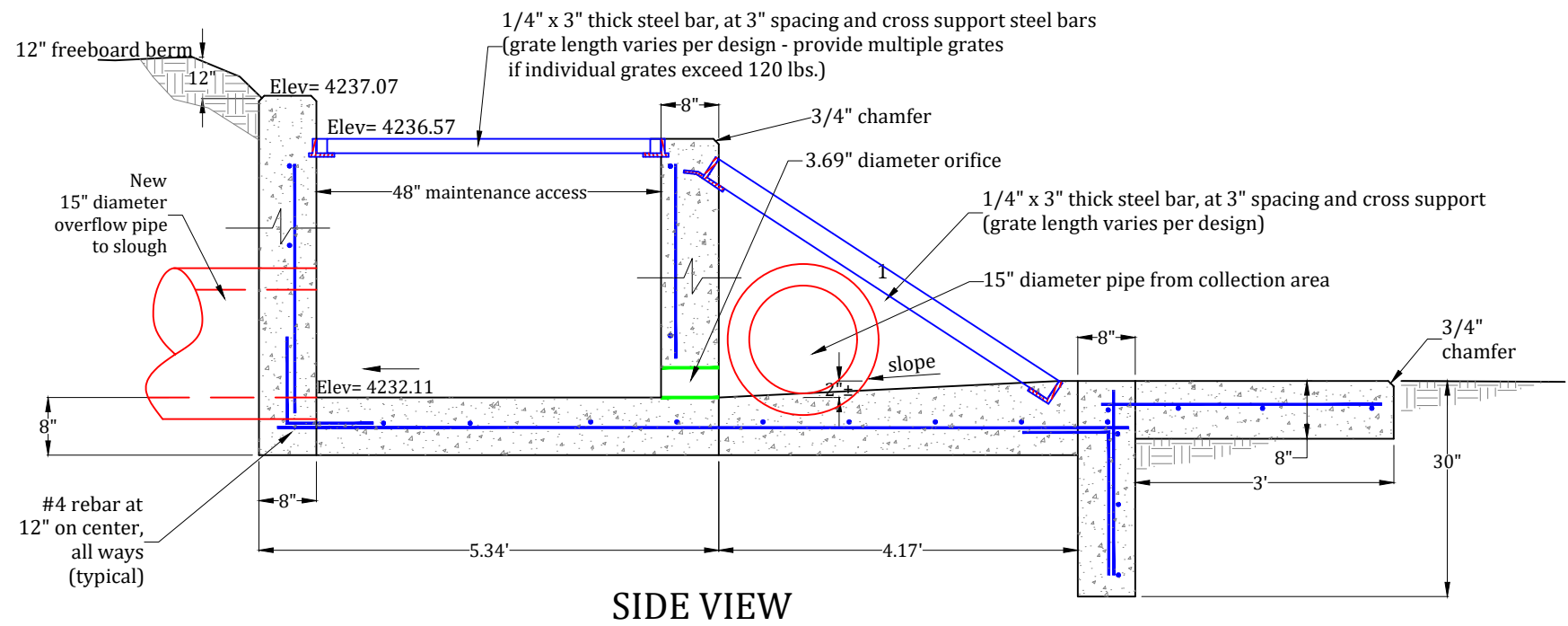

SIDE VIEW

NOTE:
All exposed concrete corners to have a 3/4" chamfered corner

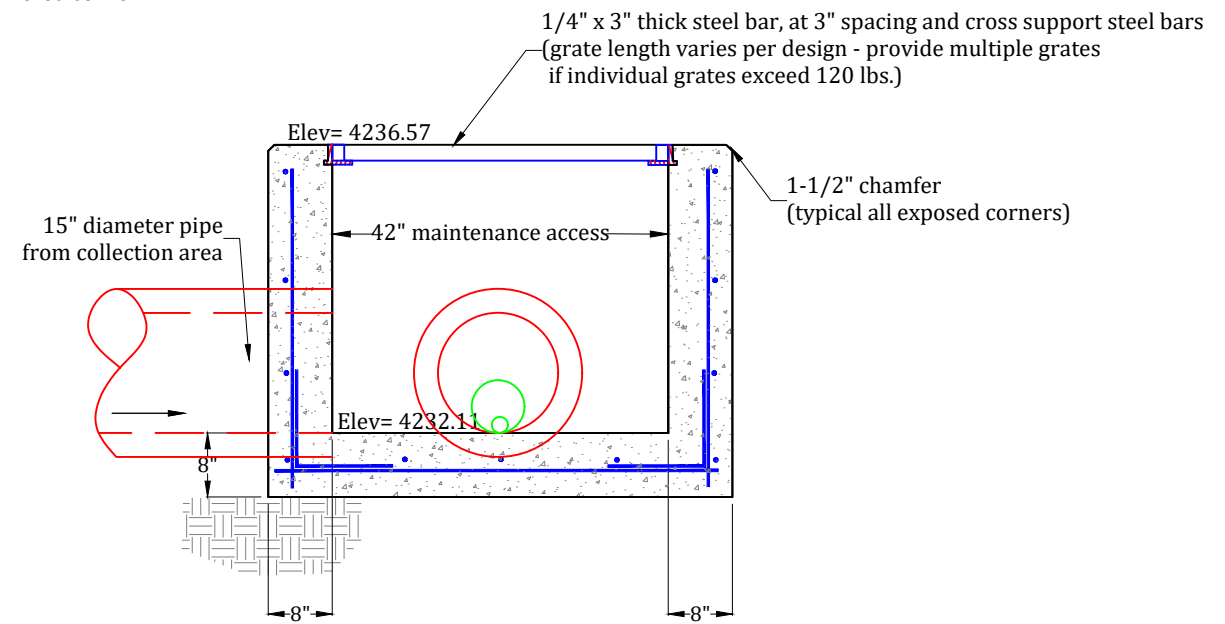

SECTION VIEW

Developer:
Pat Burns
Lync Construction
801-710-2234

Approved for Construction
Weber County Engineer
Date: _____

DETENTION POND #2
INLET/OUTLET STRUCTURE
SCALE: NONE

1

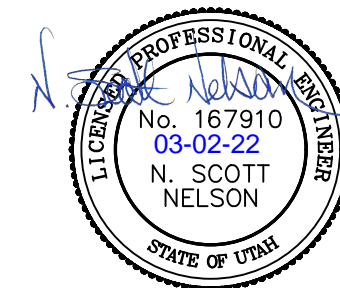

Project: IMPROVEMENTS
STAGECOACH ESTATES
WEBER COUNTY, UTAH
Title: DETAILS: DETENTION POND #2
INLET/OUTLET STRUCTURE
Date: 2 MARCH 2022

Prepared By:
Summers Engineering Collective
- Jen Summers -
Summers.eng.collective@gmail.com
| Date: | Revision:

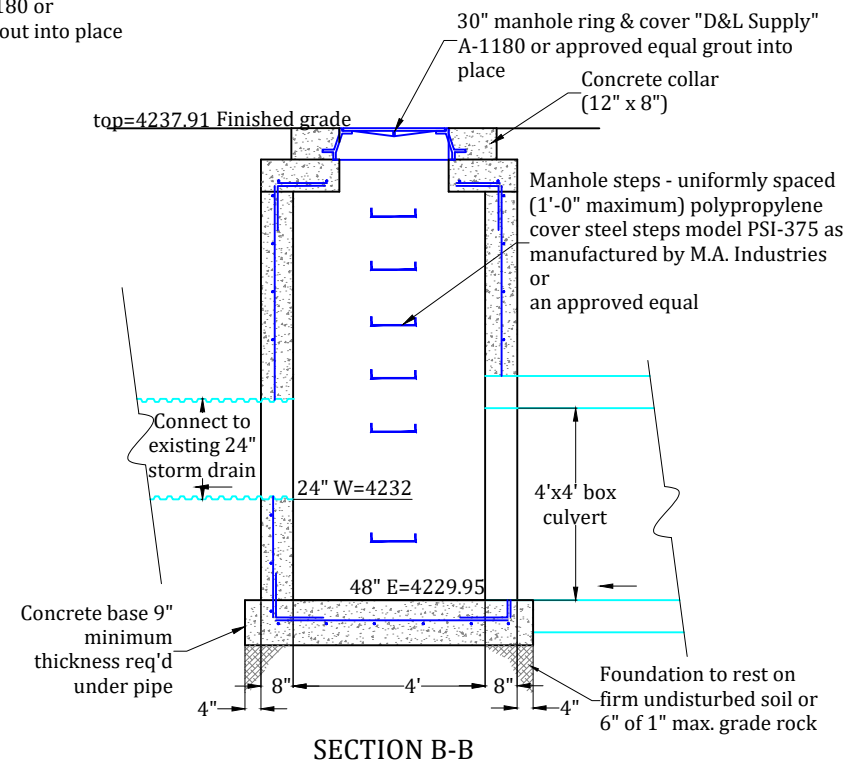
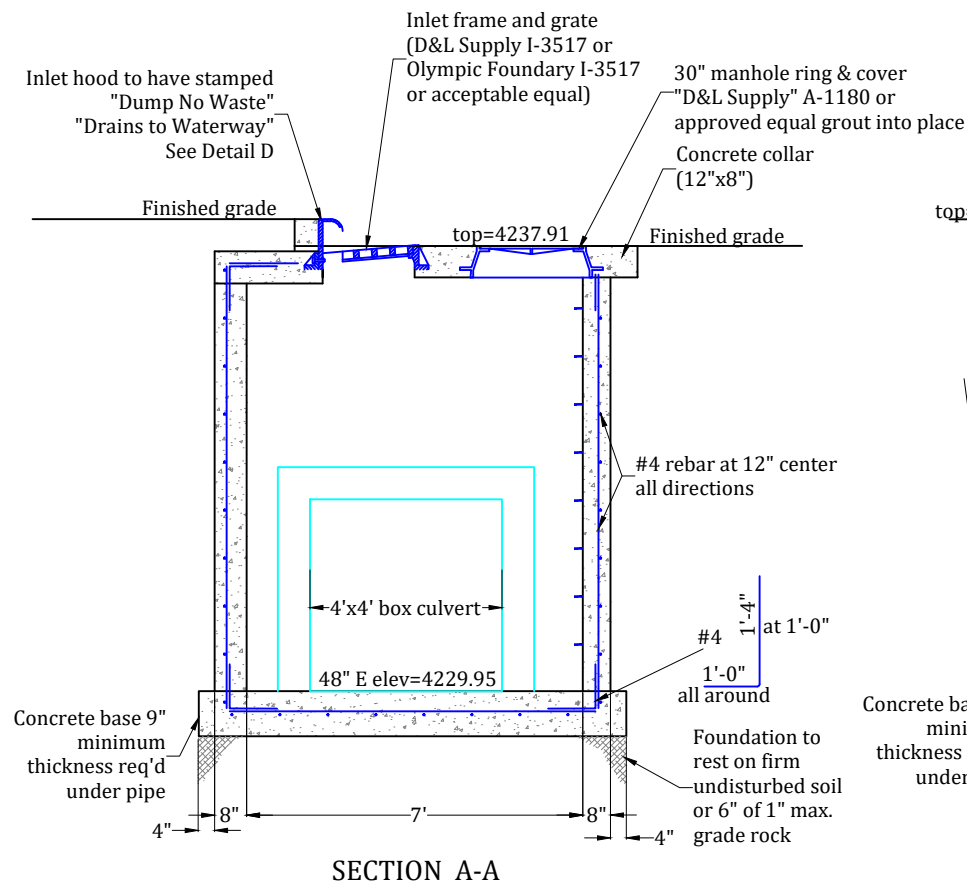
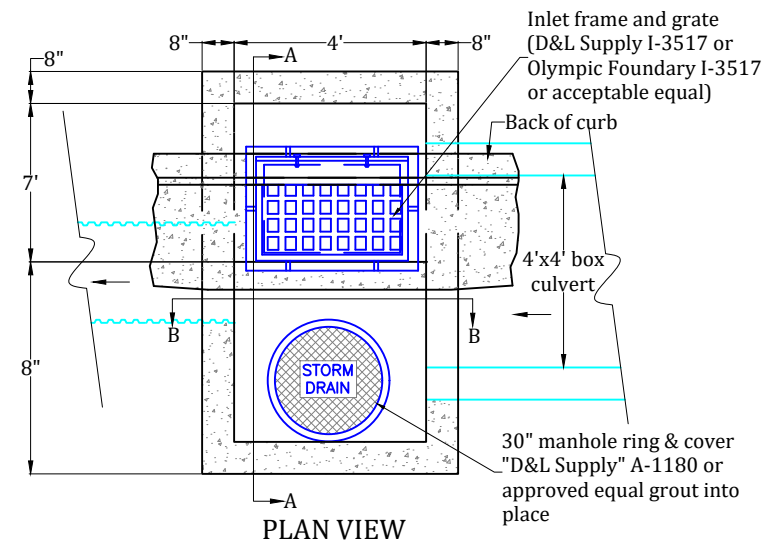

**STA 300+20
STORM DRAIN VAULT**
SCALE: NONE

1

Developer:
Pat Burns
Lync Construction
801-710-2234

Approved for Construction
Weber County Engineer
Date: _____

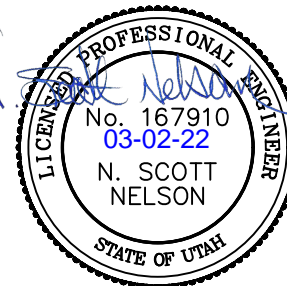

Project: **IMPROVEMENTS
STAGECOACH ESTATES
WEBER COUNTY, UTAH**

Title: **DETAILS: STORM DRAIN VAULT**

Date: 2 MARCH 2022

Prepared By:
Summers Engineering Collective
- Jen Summers -
Summers.eng.collective@gmail.com

#	Date:	Revision:

Sheet 34 of 37

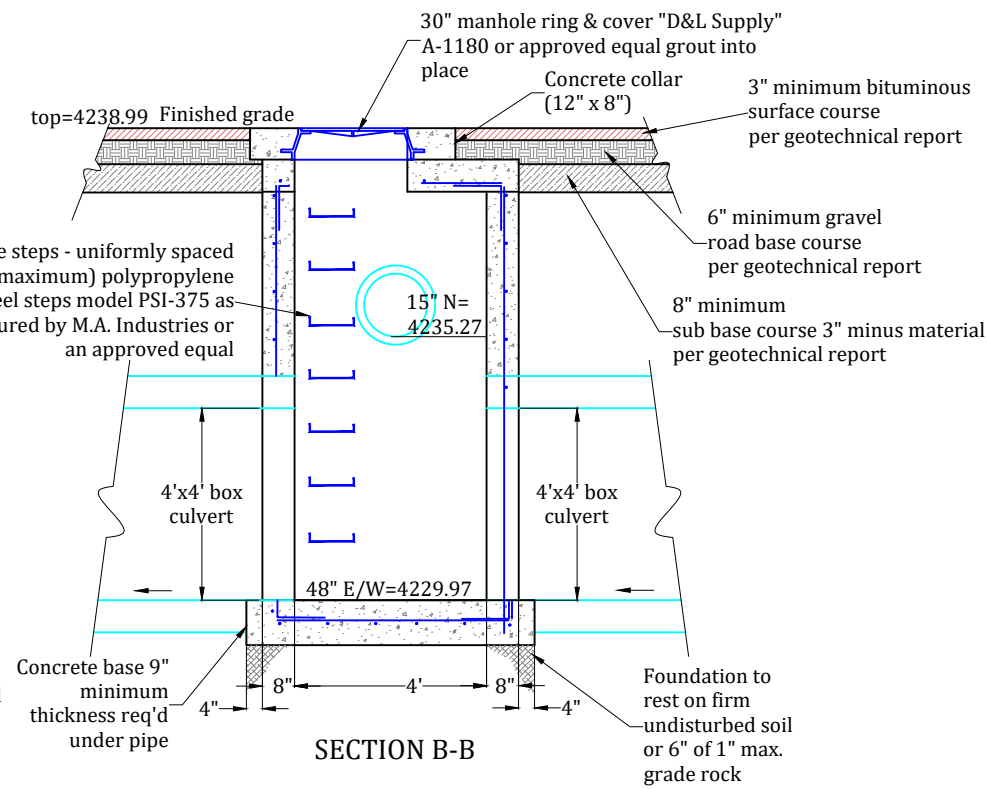
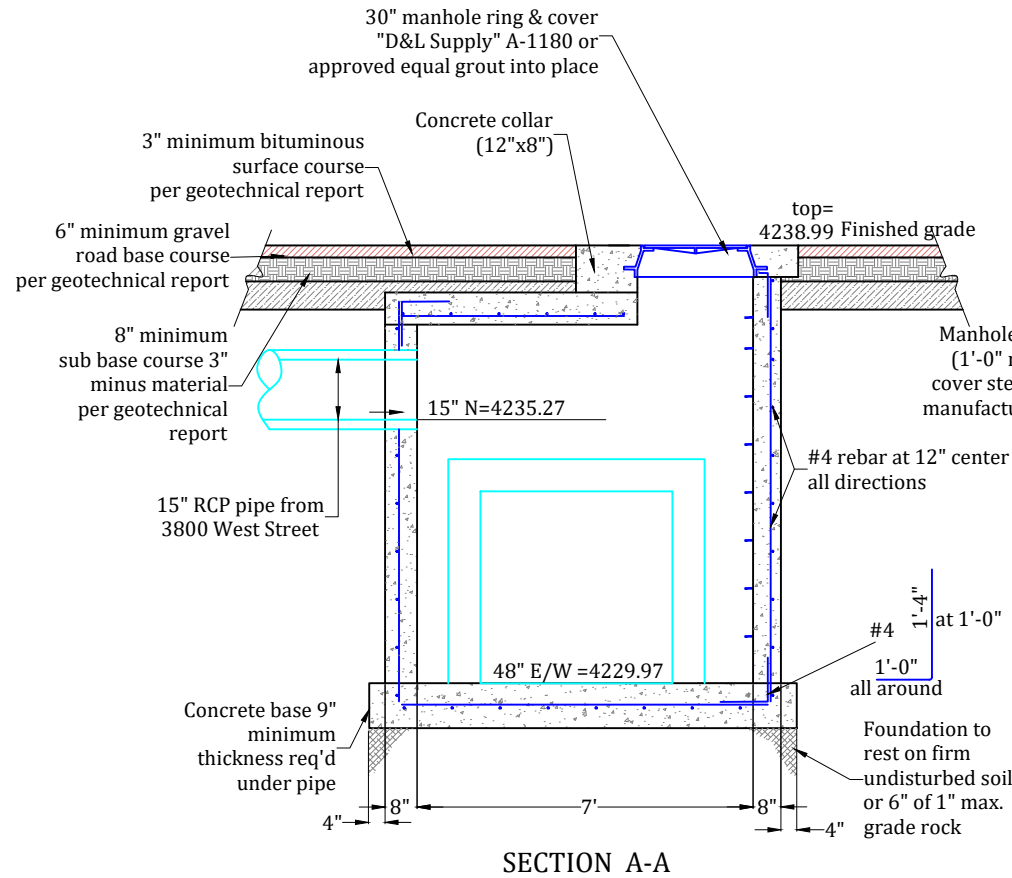
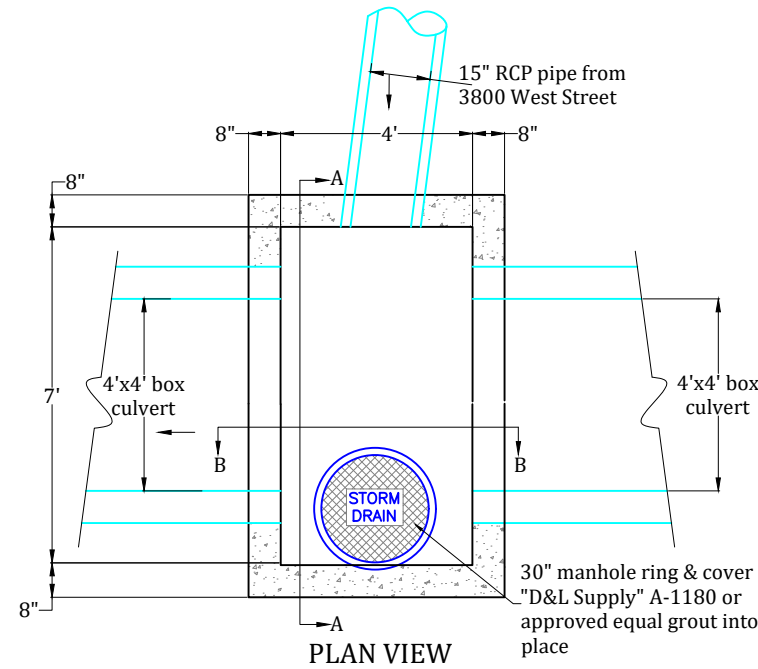

STA 301+44
STORM DRAIN VAULT
 SCALE: NONE

1

Developer:
 Pat Burns
 Lync Construction
 801-710-2234

Approved for Construction

 Weber County Engineer
 Date: _____



Project: **IMPROVEMENTS
 STAGECOACH ESTATES
 WEBER COUNTY, UTAH**

Title: **DETAILS: STORM DRAIN VAULT**

Date: **2 MARCH 2022**

Sheet **35 of 37**

Prepared By:
Summers Engineering Collective
 - Jen Summers -
 Summers.eng.collective@gmail.com

#	Date:	Revision:

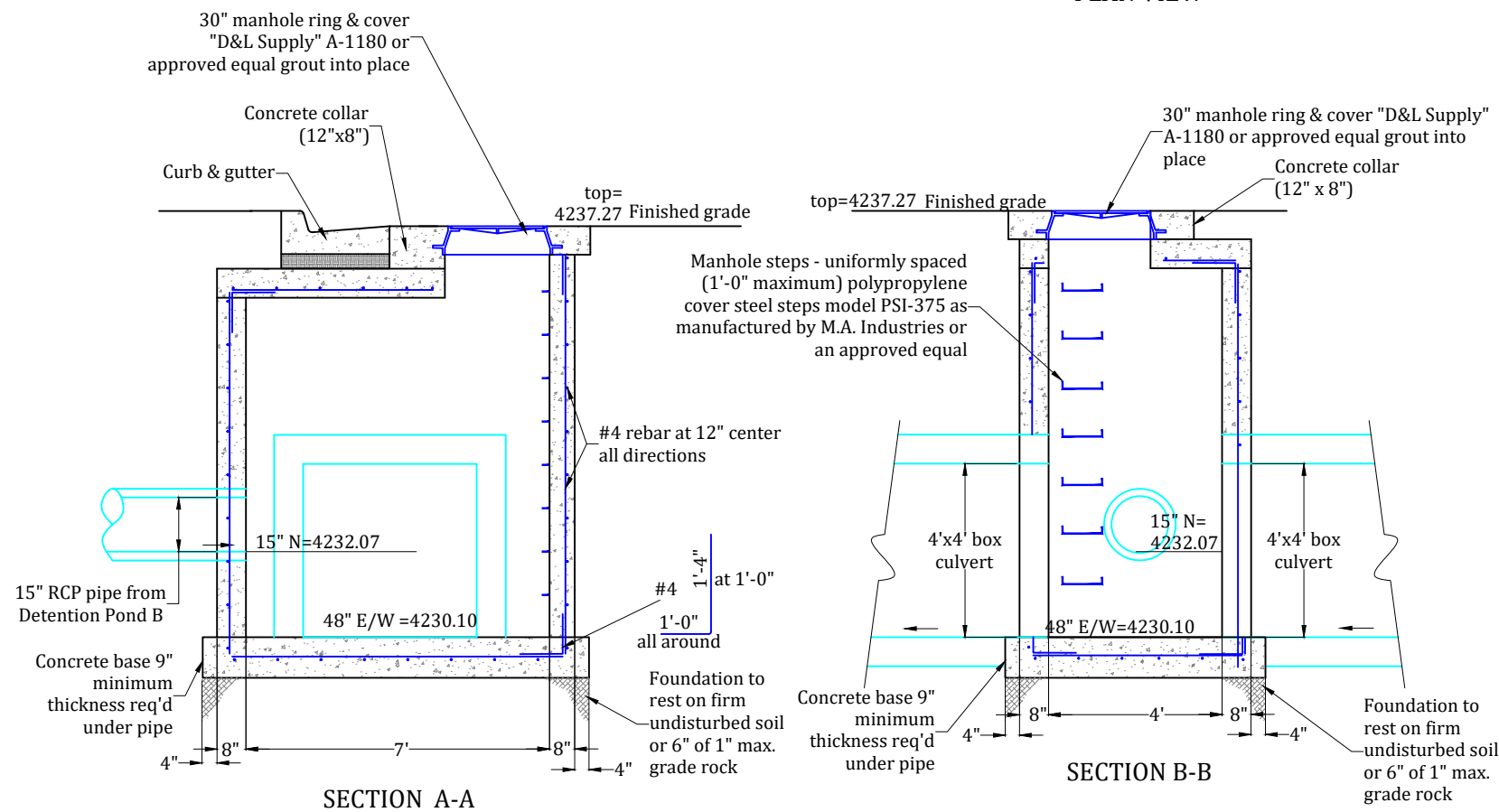
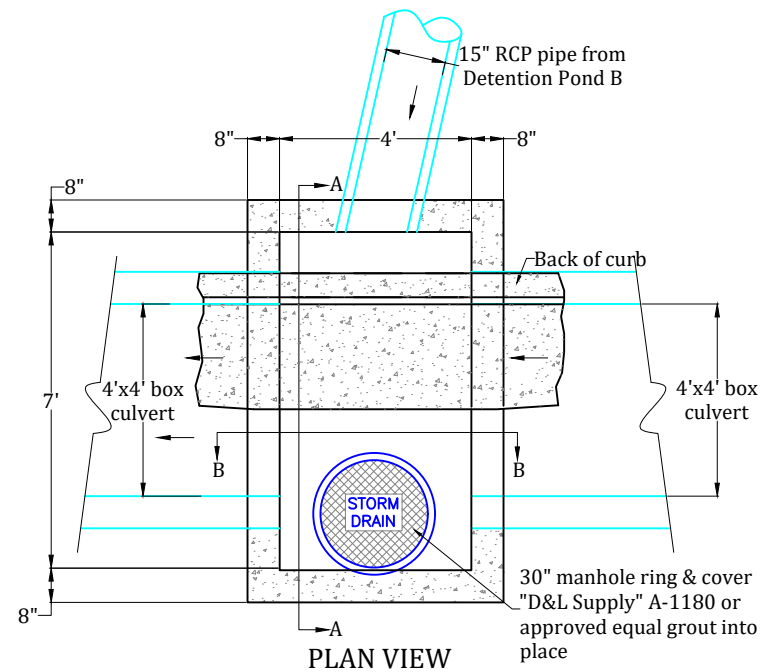

**STA 308+10
STORM DRAIN VAULT**
SCALE: NONE

1

Developer:
Pat Burns
Lync Construction
801-710-2234

Approved for Construction
Weber County Engineer
Date: _____

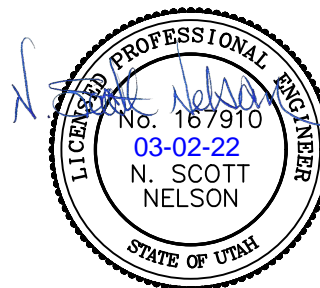

Project: IMPROVEMENTS STAGECOACH ESTATES WEBER COUNTY, UTAH		Prepared By: Summers Engineering Collective - Jen Summers - Summers.eng.collective@gmail.com	
Title: DETAILS: STORM DRAIN VAULT		#	Date: / /
Date: 2 MARCH 2022	Sheet 36 of 37	Revision:	

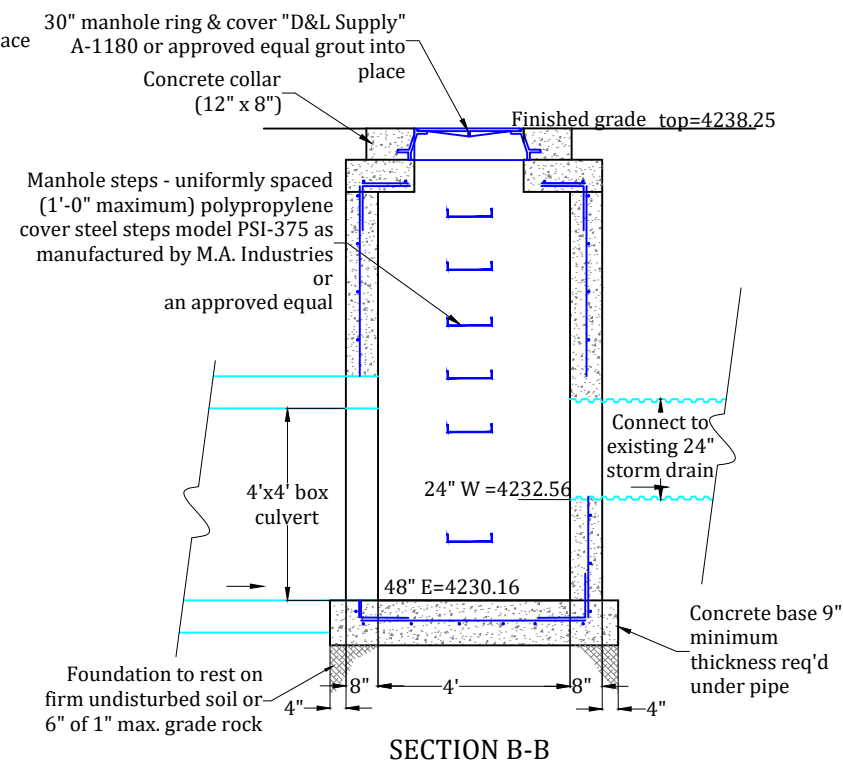
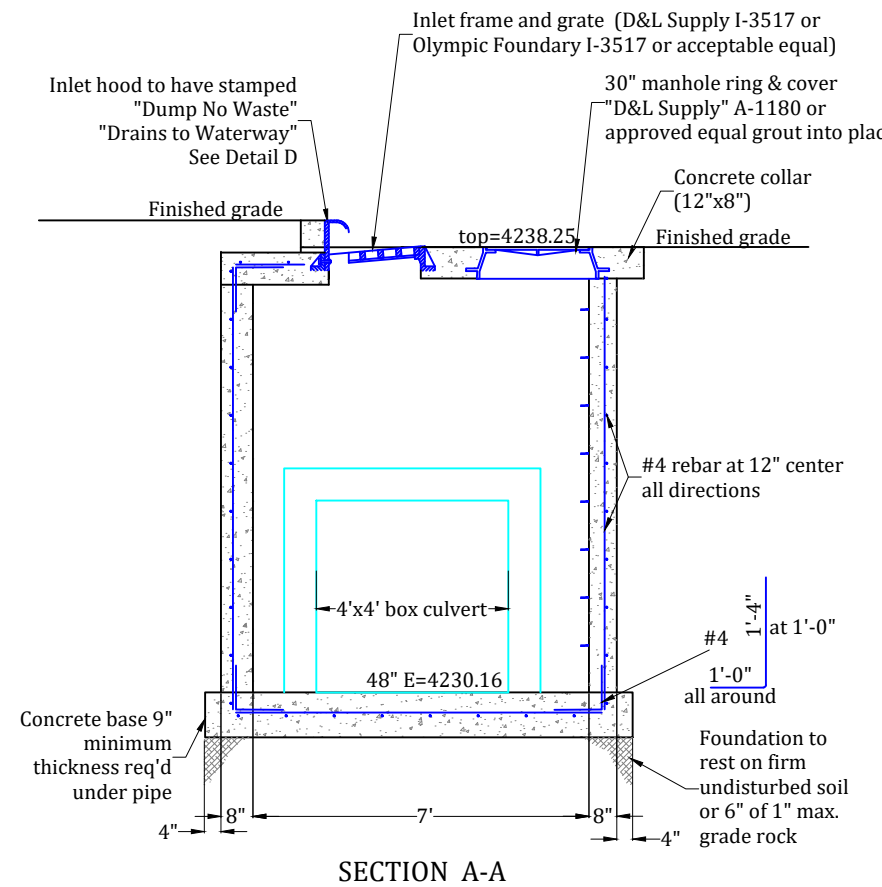
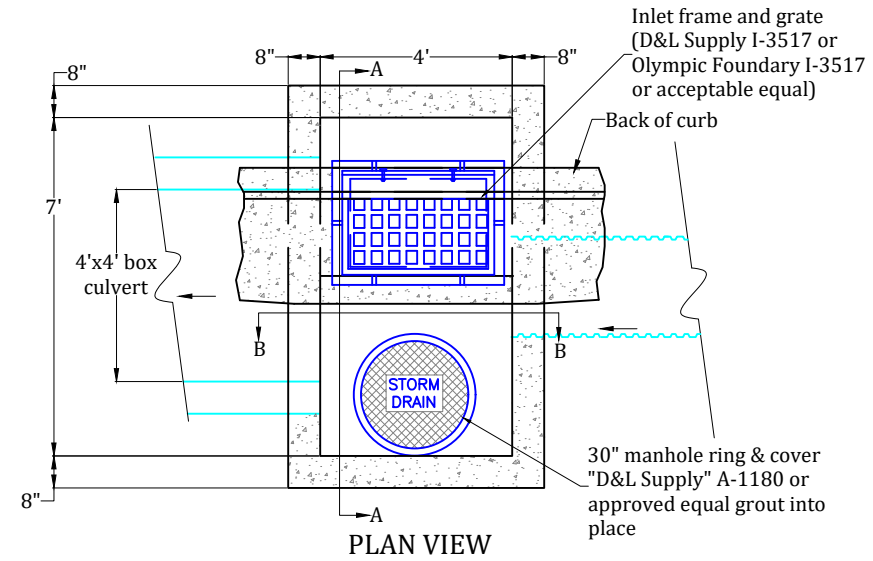

STA 313+17
STORM DRAIN VAULT
 SCALE: NONE

1
-

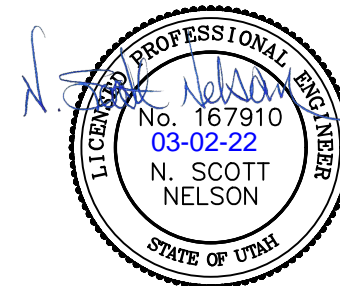

Developer:
 Pat Burns
 Lync Construction
 801-710-2234

Approved for Construction

 Weber County Engineer
 Date: _____

Project: IMPROVEMENTS STAGECOACH ESTATES WEBER COUNTY, UTAH		Prepared By: Summers Engineering Collective - Jen Summers - Summers.eng.collective@gmail.com	
Title: DETAILS: STORM DRAIN VAULT		#	Date: Revision:
Date: 2 MARCH 2022	Sheet 37 of 37		