



Land Use Permit

Weber County Planning Commission

2380 Washington Blvd. STE 240

Ogden, UT 84401

Phone: (801) 399-8791 FAX: (801) 399-8862

webercountyutah.gov/planning

Permit Number: LUP21-2022

Permit Type: Structure

Permit Date: 01/27/2022

Applicant

Name: Caden Davis

Business:

Address: 6321 W 1900 N
Warren, UT 84404

Phone:

Owner

Name: Same as Applicant

Business:

Address:
, UT

Phone:

Parcel

Parcel: 100280020

Zoning: A-2 **Area:** 10 **Sq Ft:**
Address: 6321 W 1900 N Warren, UT 84404

Lot(s): **Subdivision:**
T - R - S - QS: 6N - 3W - 01 - NE

Proposal

Proposed Structure: Pole Barn

Proposed Structure Height: 29

of Dwelling Units: 0

Off Street Parking Reqd:

Building Footprint: 8000

Max Structure Height in Zone: 35

of Accessory Bldgs: 1

***Is Structure > 1,000 Sq. Ft?** Yes

*If True Need Certif. Statement

Permit Checklist

Access Type: Front Lot Line

Greater than 4218 ft above sea level? No

Additional Setback Reqd. ? No

> 200 ft from paved Road? N/A

Culinary Water District: West Warren - Warren

Alternative Access File #

Wetlands/Flood Zone? Yes

Meet Zone Area Frontage? Yes

Hillside Review Reqd? N/A

Waste Water System: Septic

Comments

The West Davis corridor runs through the middle of this parcel. Staff has notified the applicant. The lower part of this parcel is in Zone A flood zone and is below 4218 in elevation. The elevations 4215. Engineering Department has determined that since it is for a Pole Barn and not for human occupancy and the Pole Barn will not be located on the portion of parcel within the flood zone they have no concerns.

Land Use Permit

Structure Setback Graphic: Barn, Corral, or Stable

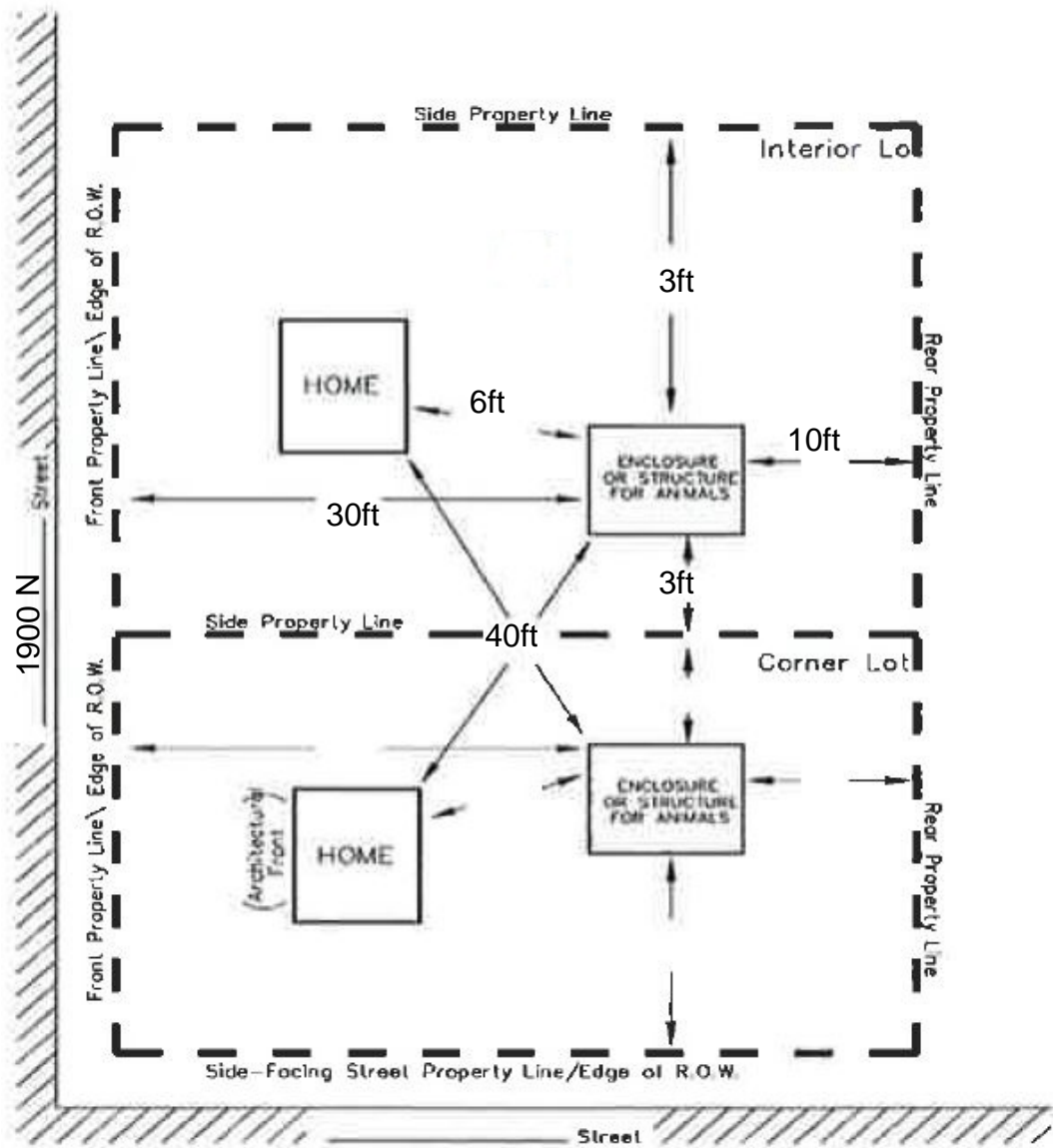

MINIMUM YARD SETBACKS Barn, Corral, or Stable

NOTICE FOR APPLICANT (Please Read Before Signing)

Proposals for the installation of an individual water supply and for a sanitary waste disposal system (septic tank) for any structure designed for human occupation must be approved by Weber County Health Department prior to installation.

Marta Borchert

01/27/2022

Planning Dept. Signature of Approval

Date

I hereby certify that I have read and examined this application and know the same to be true and correct. All provisions of laws and ordinances governing this land use will be complied with whether specified herein or not. I make this statement under penalty of perjury.

Contractor/Owner Signature of Approval

Date