

# DOUG HARBERTSON SUBDIVISION

LOCATED IN THE SOUTHWEST QUARTER OF SECTION 36,  
TOWNSHIP 7 NORTH, RANGE 3 WEST, SALT LAKE BASE AND MERIDIAN,  
WEBER COUNTY, UTAH  
SEPTEMBER 2021

## BOUNDARY DESCRIPTION

PARTS OF LOT 4 "PLAT OF SECTION 36" LOCATED IN THE WEST HALF OF SECTION 36, TOWNSHIP 7 NORTH, RANGE 3 WEST, SALT LAKE BASE AND MERIDIAN, MORE PARTICULARLY DESCRIBED AS FOLLOWS:

BEGINNING AT THE WEST QUARTER CORNER OF SAID SECTION, RUNNING THENCE ALONG THE WEST LINE OF THE NORTHWEST QUARTER OF SAID SECTION NORTH 0°11'22" EAST 119.51 FEET; THENCE SOUTH 89°48'33" EAST 307.00 FEET; THENCE SOUTH 0°11'27" WEST 150.00 FEET; THENCE NORTH 89°48'33" WEST 307.00 FEET TO THE WEST LINE OF THE SOUTHWEST QUARTER OF SAID SECTION; THENCE ALONG THE WEST LINE OF SAID SOUTHWEST QUARTER NORTH 0°11'27" EAST 30.49 FEET TO THE POINT OF BEGINNING. CONTAINING 46,095 SQUARE FEET OR 1.06 ACRES MORE OR LESS.

## SURVEYOR'S CERTIFICATE

I, KLINT H. WHITNEY, DO HEREBY CERTIFY THAT I AM A LICENSED PROFESSIONAL LAND SURVEYOR IN THE STATE OF UTAH AND THAT I HOLD CERTIFICATE NO. 8227228 IN ACCORDANCE WITH TITLE 58, CHAPTER 22, OF THE PROFESSIONAL ENGINEERS AND LAND SURVEYORS ACT. I FURTHER CERTIFY THAT BY AUTHORITY OF THE OWNERS I HAVE COMPLETED A SURVEY OF THE PROPERTY AS SHOWN AND DESCRIBED ON THIS PLAT, AND HAVE SUBDIVIDED SAID PROPERTY INTO LOTS AND STREETS, TOGETHER WITH EASEMENTS, HEREAFTER TO BE KNOWN AS DOUG HARBERTSON SUBDIVISION IN ACCORDANCE WITH SECTION 17-23-17 AND HAVE VERIFIED ALL MEASUREMENTS; THAT THE REFERENCE MONUMENTS SHOWN HEREON ARE LOCATED AS INDICATED AND ARE SUFFICIENT TO RETRACE OR REESTABLISH THIS SURVEY; THAT ALL LOTS MEET THE REQUIREMENTS OF THE LAND USE CODE; AND THAT THE INFORMATION SHOWN HEREIN IS SUFFICIENT TO ACCURATELY ESTABLISH THE LATERAL BOUNDARIES OF THE HEREIN DESCRIBED TRACT OF REAL PROPERTY.

SIGNED THIS \_\_\_\_\_ DAY OF \_\_\_\_\_, 2021.



KLINT H. WHITNEY, PLS NO. 8227228

## OWNER'S DEDICATION

I THE UNDERSIGNED OWNER OF THE HEREON DESCRIBED TRACT OF LAND, HEREBY SET APART AND SUBDIVIDE THE SAME INTO LOTS, PARCELS AND STREETS AS SHOWN ON THIS PLAT AND NAME SAID TRACT:

## DOUG HARBERTSON SUBDIVISION

AND HEREBY DEDICATE, GRANT AND CONVEY TO WEBER COUNTY, UTAH ALL THOSE PARTS OR PORTIONS OF SAID TRACT OF LAND DESIGNATED AS ROADWAY DEDICATION, THE SAME TO BE USED AS PUBLIC THOROUGHFARES FOREVER, AND ALSO GRANT AND DEDICATE A PERPETUAL EASEMENT OVER, UPON AND UNDER THE LANDS DESIGNATED ON THE PLAT AS PUBLIC UTILITY, THE SAME TO BE USED FOR THE INSTALLATION, MAINTENANCE AND OPERATION OF PUBLIC UTILITY SERVICE LINES, STORM DRAINAGE FACILITIES OR FOR THE PERPETUAL PRESERVATION OF WATER DRAINAGE CHANNELS IN THEIR NATURAL STATE WHICHEVER IS APPLICABLE AS MAY BE AUTHORIZED BY WEBER COUNTY, UTAH, AND ALSO DEDICATE TO WEBER COUNTY A SLOUGH EASEMENT FOR DRAINAGE AND RUNOFF, WITH NO BUILDINGS OR STRUCTURES BEING ERECTED WITHIN SUCH EASEMENTS AND FOR THE PERPETUAL PRESERVATION OF DRAINAGE IN ITS NATURAL STATE OR AS AUTHORIZED BY WEBER COUNTY.

SIGNATURE \_\_\_\_\_ DATE: \_\_\_\_\_  
EDWARD H. HARBERTSON, JR. AS TO AN UNDIVIDED 3/6THS INTEREST

SIGNATURE \_\_\_\_\_ DATE: \_\_\_\_\_  
STACEY LEE ADAMS AS TO AN UNDIVIDED 1/6TH INTEREST

SIGNATURE \_\_\_\_\_ DATE: \_\_\_\_\_  
DOUGLAS JAMES HARBERTSON AS TO AN UNDIVIDED 1/6TH INTEREST

SIGNATURE \_\_\_\_\_ DATE: \_\_\_\_\_  
GUY PAUL HARBERTSON AS TO AN UNDIVIDED 1/6TH INTEREST

## ACKNOWLEDGEMENT

STATE OF UTAH )  
COUNTY OF WEBER )

On this \_\_\_\_\_ day of \_\_\_\_\_, 2021, before me \_\_\_\_\_, A Notary Public, personally appeared  
**EDWARD H. HARBERTSON, JR.**, Proved on the basis of satisfactory evidence to be the person(s) whose name(s) (is/are) subscribed to this instrument, and acknowledged (he/she/they) executed the same. Witness my hand and official seal.

## ACKNOWLEDGEMENT

STATE OF UTAH )  
COUNTY OF WEBER )

On this \_\_\_\_\_ day of \_\_\_\_\_, 2021, before me \_\_\_\_\_, A Notary Public, personally appeared  
**STACEY LEE ADAMS**, Proved on the basis of satisfactory evidence to be the person(s) whose name(s) (is/are) subscribed to this instrument, and acknowledged (he/she/they) executed the same. Witness my hand and official seal.

STAMP \_\_\_\_\_ NOTARY PUBLIC

STAMP \_\_\_\_\_ NOTARY PUBLIC

## ACKNOWLEDGEMENT

STATE OF UTAH )  
COUNTY OF WEBER )

On this \_\_\_\_\_ day of \_\_\_\_\_, 2021, before me \_\_\_\_\_, A Notary Public, personally appeared  
**DOUGLAS JAMES HARBERTSON**, Proved on the basis of satisfactory evidence to be the person(s) whose name(s) (is/are) subscribed to this instrument, and acknowledged (he/she/they) executed the same. Witness my hand and official seal.

## ACKNOWLEDGEMENT

STATE OF UTAH )  
COUNTY OF WEBER )

On this \_\_\_\_\_ day of \_\_\_\_\_, 2021, before me \_\_\_\_\_, A Notary Public, personally appeared  
**GUY PAUL HARBERTSON**, Proved on the basis of satisfactory evidence to be the person(s) whose name(s) (is/are) subscribed to this instrument, and acknowledged (he/she/they) executed the same. Witness my hand and official seal.

STAMP \_\_\_\_\_ NOTARY PUBLIC

STAMP \_\_\_\_\_ NOTARY PUBLIC

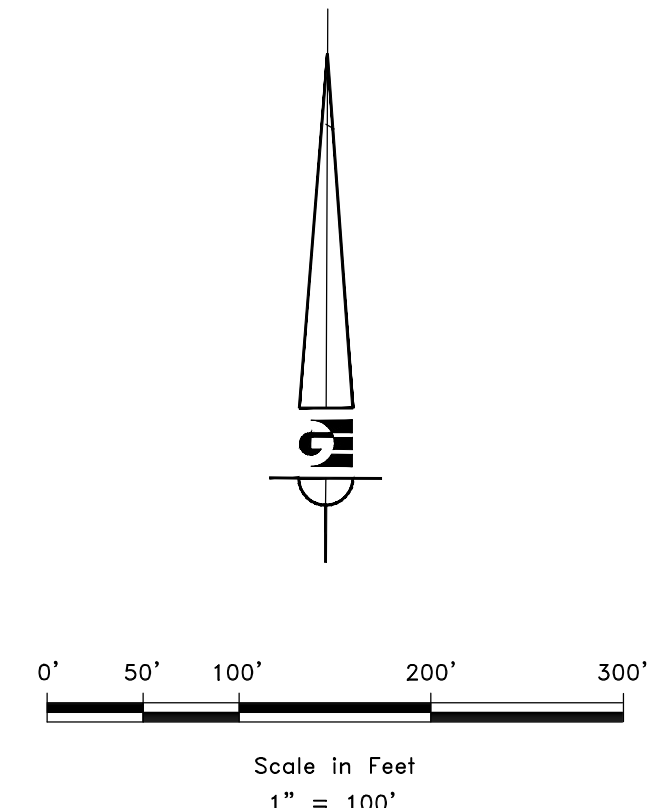
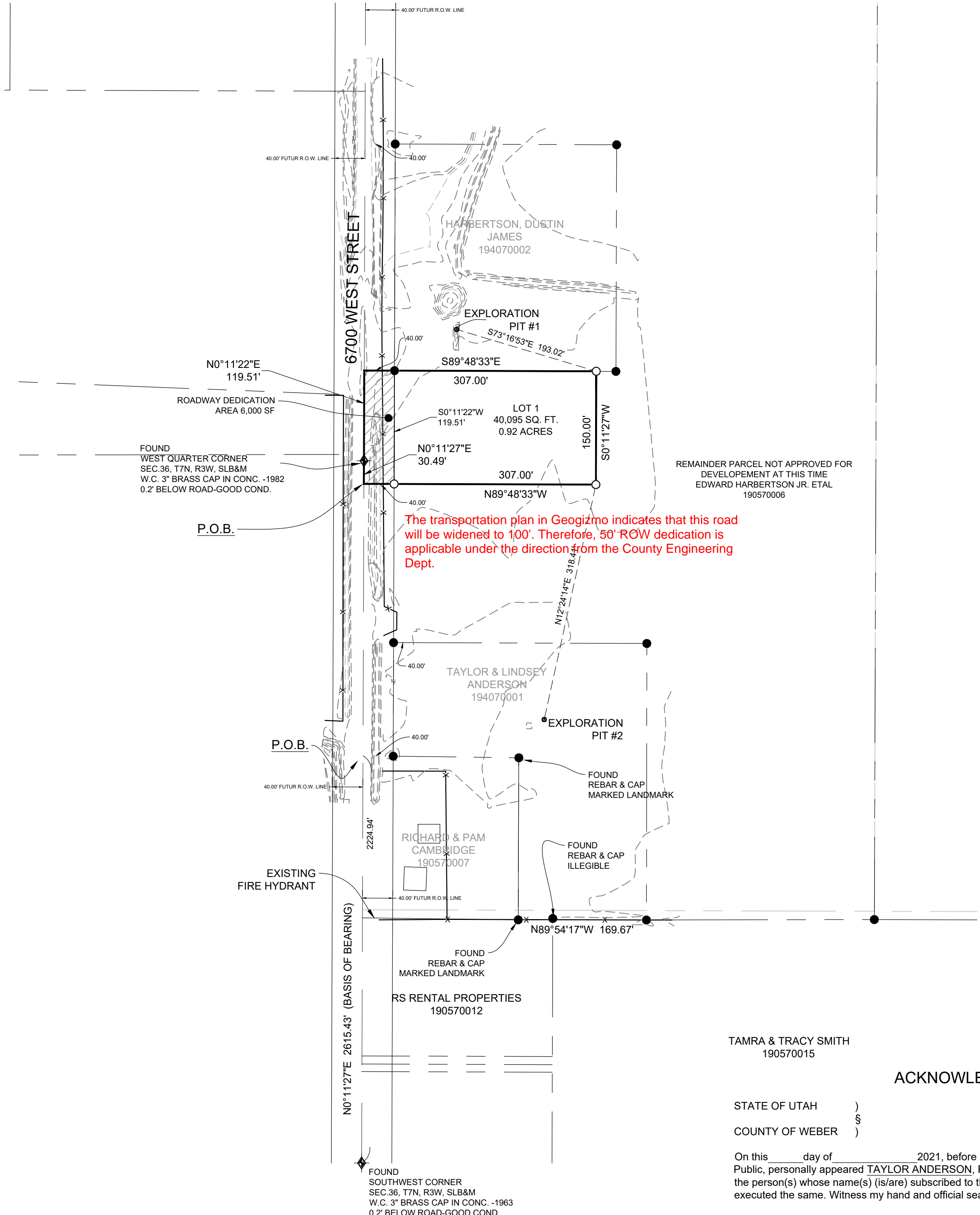

### LEGEND

- ◆ WEBER COUNTY MONUMENT AS NOTED
- SET 24" REBAR AND CAP MARKED GARDNER ENGINEERING
- FOUND REBAR AND CAP MARKED GARDNER ENGINEERING (UNLESS OTHERWISE NOTED)
- SUBDIVISION BOUNDARY
- LOT LINE
- - - ADJACENT PARCEL
- SECTION LINE
- - - EASEMENT
- X — EXISTING FENCE LINE

### VICINITY MAP

NOT TO SCALE

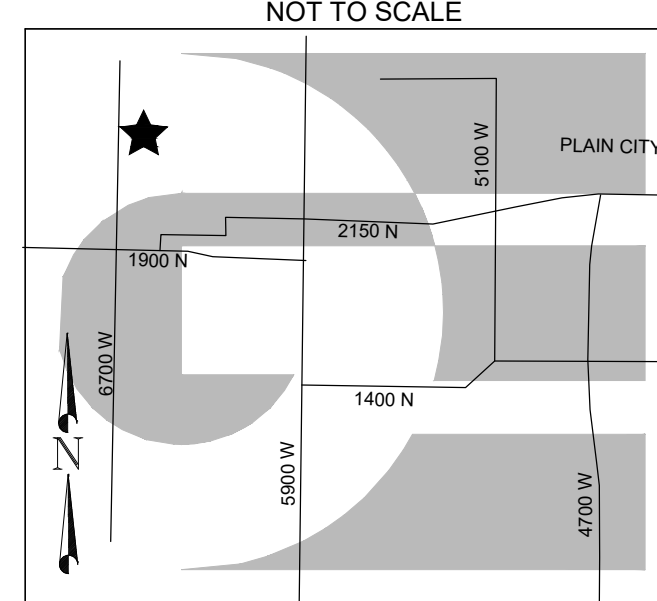

### SOIL NOTES

EXPLORATION PIT #1 EVALUATION #14817  
0-16" LOAM, GRANULAR STRUCTURE  
16-36" LOAMY FINE SAND, SINGLE GRAIN  
36-77" SILTY CLAY LOAM, MASSIVE STRUCTURE  
OBSERVED GROUNDWATER TABLE 77"  
DOCUMENTED GROUNDWATER TABLE 12"

EXPLORATION PIT #2 (WASTE WATER SITE AND SOILS EVALUATION #14818)  
0-15" Loam, GRANULAR STRUCTURE  
15-40" SILTY CLAY LOAM, BLOCKY STRUCTURE  
40-62" SILT LOAM, BLOCKY STRUCTURE  
OBSERVED GROUNDWATER TABLE 62"  
DOCUMENTED GROUNDWATER TABLE 12"

### NOTES

1. ZONE (A-2) CURRENT YARD SETBACKS: FRONT-30' // SIDE-10' TOTAL WIDTH OF 2 SIDE YARDS NOT LESS THAN 24' // REAR-30'
2. SUBJECT PROPERTY FALLS WITHIN FEMA FLOOD ZONE "X" - AREAS DETERMINED TO BE OUTSIDE THE 0.2% ANNUAL CHANCE FLOODPLAIN. PER FEMA MAP NO. 49057C0175E WITH AN EFFECTIVE DATE OF DECEMBER 16, 2005.
3. DUE TO THE TOPOGRAPHY AND THE LOCATION OF THIS SUBDIVISION ALL OWNERS WILL ACCEPT RESPONSIBILITY FOR ANY STORM WATER RUNOFF FROM THE ROAD ADJACENT TO THIS PROPERTY UNTIL CURB AND GUTTER IS INSTALLED.
4. THE REMAINDER AGRICULTURAL PARCEL IS NOT APPROVED FOR DEVELOPMENT.

AGRICULTURAL NOTE:  
AGRICULTURE IS THE PREFERRED USE IN THE AGRICULTURE ZONES. AGRICULTURE OPERATIONS AS SPECIFIED IN THE ZONING ORDINANCE FOR A PARTICULAR ZONE ARE PERMITTED AT ANY TIME INCLUDING THE OPERATION OF FARM MACHINERY AND NO ALLOWED AGRICULTURE USE SHALL BE SUBJECT TO RESTRICTION ON THAT IT INTERFERES WITH ACTIVITIES OF FUTURE RESIDENTS OF THIS SUBDIVISION.

## ACKNOWLEDGEMENT

TAMRA & TRACY SMITH  
190570015

STATE OF UTAH )  
COUNTY OF WEBER )

On this \_\_\_\_\_ day of \_\_\_\_\_, 2021, before me \_\_\_\_\_, A Notary Public, personally appeared **TAYLOR ANDERSON**, Proved on the basis of satisfactory evidence to be the person(s) whose name(s) (is/are) subscribed to this instrument, and acknowledged (he/she/they) executed the same. Witness my hand and official seal.

STAMP \_\_\_\_\_ NOTARY PUBLIC

### WEBER COUNTY SURVEYOR

I HEREBY CERTIFY THAT THE WEBER COUNTY SURVEYOR'S OFFICE HAS REVIEWED THIS PLAT AND ALL CONDITIONS FOR APPROVAL BY THIS OFFICE HAVE BEEN SATISFIED. THE APPROVAL OF THIS PLAT BY THE WEBER COUNTY SURVEYOR DOES NOT RELIEVE THE LICENSED LAND SURVEYOR WHO EXECUTED THIS PLAT FROM THE RESPONSIBILITIES AND/OR LIABILITIES ASSOCIATED THEREWITH.

SIGNED THIS \_\_\_\_\_ DAY OF \_\_\_\_\_, 2021.

\_\_\_\_\_  
COUNTY SURVEYOR

### WEBER COUNTY ATTORNEY

I HAVE EXAMINED THE FINANCIAL GUARANTEE AND OTHER DOCUMENTS ASSOCIATED WITH THIS SUBDIVISION PLAT AND IN MY OPINION THEY CONFORM WITH THE COUNTY ORDINANCE APPLICABLE THERETO AND NOW IN FORCE AND EFFECT.

SIGNED THIS \_\_\_\_\_ DAY OF \_\_\_\_\_, 2021.

\_\_\_\_\_  
COUNTY ATTORNEY

### WEBER COUNTY ENGINEER

I HEREBY CERTIFY THAT THE REQUIRED PUBLIC IMPROVEMENT STANDARDS AND DRAWINGS FOR THIS SUBDIVISION CONFORM WITH COUNTY STANDARDS AND THE AMOUNT OF THE FINANCIAL GUARANTEE IS SUFFICIENT FOR THE INSTALLATION OF THESE IMPROVEMENTS.

SIGNED THIS \_\_\_\_\_ DAY OF \_\_\_\_\_, 2021.

\_\_\_\_\_  
COUNTY ENGINEER

### WEBER COUNTY COMMISSION ACCEPTANCE

THIS IS TO CERTIFY THAT THIS SUBDIVISION PLAT, THE DEDICATION OF STREETS AND OTHER PUBLIC WAYS AND FINANCIAL GUARANTEE OF PUBLIC IMPROVEMENTS ASSOCIATED WITH THIS SUBDIVISION THEREON ARE HEREBY APPROVED AND ACCEPTED BY THE COMMISSIONERS OF WEBER COUNTY, UTAH.

SIGNED THIS \_\_\_\_\_ DAY OF \_\_\_\_\_, 2021.

\_\_\_\_\_  
CHAIRMAN, WEBER COUNTY COMMISSION

ATTEST: \_\_\_\_\_  
NAME/TITLE

### WEBER COUNTY PLANNING COMMISSION APPROVAL

THIS IS TO CERTIFY THAT THIS SUBDIVISION WAS DULY APPROVED BY THE WEBER COUNTY PLANNING COMMISSION.

SIGNED THIS \_\_\_\_\_ DAY OF \_\_\_\_\_, 2021.

\_\_\_\_\_  
CHAIRMAN, WEBER COUNTY PLANNING COMMISSION

### WEBER - MORGAN HEALTH DEPARTMENT

I DO HEREBY CERTIFY THAT THE SOILS, PERCOLATION RATES, AND SITE CONDITION FOR THIS SUBDIVISION HAVE BEEN INVESTIGATED BY THIS OFFICE AND ARE APPROVED FOR ON-SITE WASTEWATER DISPOSAL SYSTEMS.

SIGNED THIS \_\_\_\_\_ DAY OF \_\_\_\_\_, 2021.

\_\_\_\_\_  
DIRECTOR WEBER-MORGAN HEALTH DEPT.

### NARRATIVE

THE PURPOSE OF THIS SURVEY WAS TO CREATE A 1 LOT SUBDIVISION WITH REMAINDER PARCEL AS SHOWN AND NOTED HEREON. SEE RECORD OF SURVEY #6129. SURVEY WAS ORDERED BY DOUG HARBERTSON. THE BASIS OF BEARING IS THE WEST LINE OF THE SOUTHWEST QUARTER OF SECTION 36, TOWNSHIP 7 NORTH, RANGE 3 WEST, OF THE SALT LAKE BASE AND MERIDIAN WHICH BEARS NORTH 00°11'27" EAST WEBER COUNTY, UTAH NORTH, NAD 83 STATE PLANE GRID BEARING. WARRANTY DEED RECORDED AS ENTRY NUMBER 2915375, DEEDS OF ADJOINING PROPERTIES, THE PLAT OF SECTION 36 BOOK 6 PAGE 71 AND EXISTING FENCE LINES WERE USED TO DETERMINE BOUNDARY LOCATION.

DEVELOPER: TRIPLE H EXCAVATION 1666 S 1900 W WEST HAVEN, UT 84401 801-436-3779	<b>S1</b> <hr/> <b>1</b>	COUNTY RECORDER ENTRY NO. _____ FEE PAID _____ FILED FOR AND RECORDED _____ AT _____ IN BOOK _____ OF OFFICIAL _____ RECORDS, PAGE _____ RECORDED _____ FOR _____ COUNTY RECORDER BY: _____
<b>GARDNER ENGINEERING</b> CIVIL • LAND PLANNING MUNICIPAL • LAND SURVEYING 5150 SOUTH 875 EAST OGDEN, UT OFFICE: 801.476.0202 FAX: 801.476.0066		