

SUNCREST MEADOWS SUBDIVISION - PH3

LOCATED IN THE NORTHWEST QUARTER OF SECTION 32,
TOWNSHIP 6 NORTH, RANGE 2 WEST, SALT LAKE BASE AND MERIDIAN,
WEBER COUNTY, UTAH
APRIL 2021

NORTHEAST COR SECTION 32,
T6N, R2W, S16B.M. (FOUND WEBER
COUNTY 3" BRASS CAP MONUMENT
6" BELOW GROUND, IN GOOD
CONDITION, DATED 2003)

NORTH QUARTER COR SECTION 32,
T6N, R2W, S16B.M. (FOUND WEBER
COUNTY 3" BRASS CAP MONUMENT
4" BELOW ASPHALT, IN FAIR
CONDITION, DATED 1963.)

VICINITY MAP

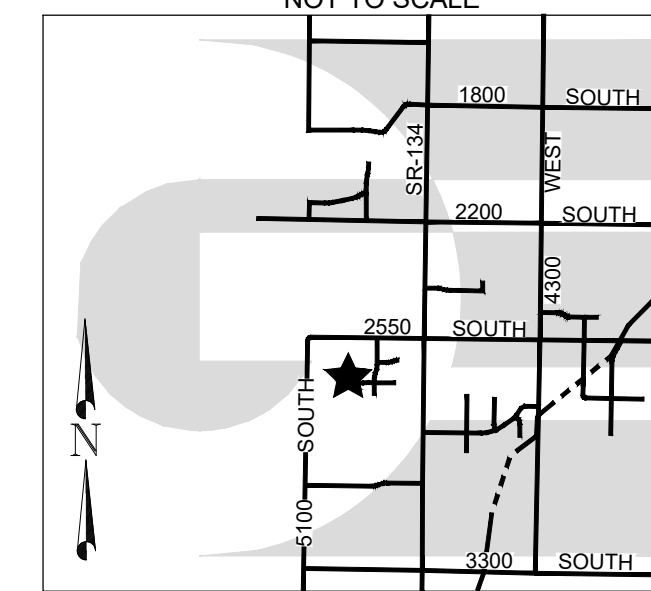

BOUNDARY DESCRIPTION

A PART OF THE NORTHWEST QUARTER OF SECTION 32, TOWNSHIP 6 NORTH, RANGE 2 WEST OF THE SALT LAKE BASE AND MERIDIAN, MORE PARTICULARLY DESCRIBED AS FOLLOWS:
BEGINNING AT POINT BEING LOCATED NORTH 89°06'33" WEST 1362.64 FEET ALONG THE NORTH SECTION LINE OF SAID SECTION 32 AND SOUTH 00°41'00" WEST 523.02 FEET ALONG THE WEST BOUNDARY LINE OF SUNCREST MEADOWS SUBDIVISION PHASE 1 FROM THE NORTH QUARTER CORNER OF SAID SECTION 32; RUNNING THENCE ALONG THE SAID WEST BOUNDARY LINE OF SUNCREST MEADOWS SUBDIVISION PHASE 1 THE FOLLOWING TWO (2) COURSES: (1) SOUTH 00°41'00" WEST 120.69 FEET; (2) SOUTH 09°58'17" WEST 149.64 FEET TO THE NORTH BOUNDARY LINE OF SUNCREST MEADOWS SUBDIVISION PHASE 2; THENCE ALONG SAID NORTH BOUNDARY LINE NORTH 89°19'00" WEST 127.98 FEET TO THE WEST BOUNDARY LINE OF SAID SUNCREST MEADOWS SUBDIVISION PHASE 2; THENCE ALONG SAID WEST BOUNDARY LINE OF SAID SUNCREST MEADOWS SUBDIVISION PHASE 2 SOUTH 01°07'57" WEST 288.76 FEET TO THE SOUTH RIGHT-OF-WAY LINE OF 2700 SOUTH STREET; THENCE ALONG SAID SOUTH RIGHT-OF-WAY LINE ALONG THE ARC OF A 1030.00 FOOT RADIUS CURVE TO THE LEFT 50.41 FEET, HAVING A CENTRAL ANGLE OF 02°48'14" CHORD BEARS NORTH 85°57'46" EAST 50.41 FEET; THENCE ALONG SAID WEST BOUNDARY LINE OF SUNCREST MEADOWS SUBDIVISION PHASE 2 SOUTH 00°39'30" WEST 246.83 FEET; THENCE NORTH 89°07'34" WEST 517.87 FEET; THENCE NORTH 00°43'56" EAST 818.73 FEET; THENCE SOUTH 89°06'44" EAST 282.77 FEET; THENCE SOUTH 71°53'53" EAST 62.31 FEET; THENCE SOUTH 89°06'44" EAST 279.01 FEET TO THE POINT OF BEGINNING. CONTAINING 9.915 ACRES.

REMAINDER PARCEL NOT APPROVED
FOR DEVELOPMENT AT THIS TIME

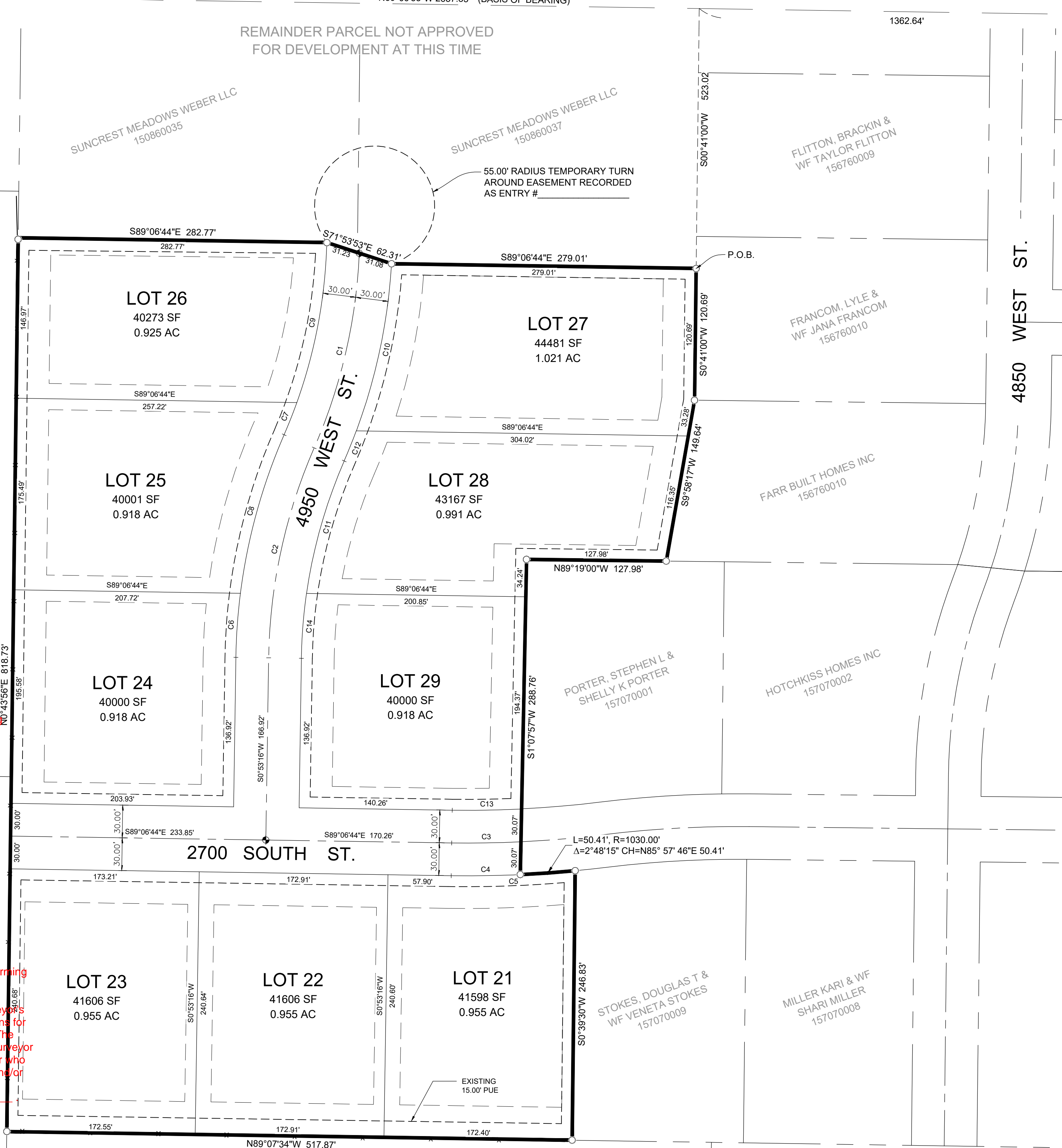

A house number indicating the street address for each lot within the subdivision shall be assigned by the county surveyor. WCO 106-1-8(c)(1)j
Addresses need to be shown for each lot. Addresses were provided on the address review submitted on 8/11/2021.

Permanent street monuments shall be accurately set at points necessary to establish all lines of the street. Centerline monuments shall be noted on the final plat. WCO 106-4-2(g) & WCO 106-1-8(c)(1)j
MIA needs to be signed and notarized along with the payment before the Weber County Surveyors Office will sign the plat.

"When street monuments are required, send 'Subdivision Monumentation Letter' to developer of Subdivision to notify of the MIA and its associated costs.

A signature block for County Surveyor conforming to state code and county ordinance. Weber County Surveyors Office has reviewed this plat and all conditions for approval by this office have been satisfied. The approval of this plat by the Weber County Surveyor does not relieve the Licensed Land Surveyor who executed this plat from the responsibilities and/or liabilities associated therewith. Signed this _____ day of _____, 2021.

Weber County Surveyor
Record of Survey #
WCO 106-1-8(c)(1)h,10; WCO 45-4-2(c)

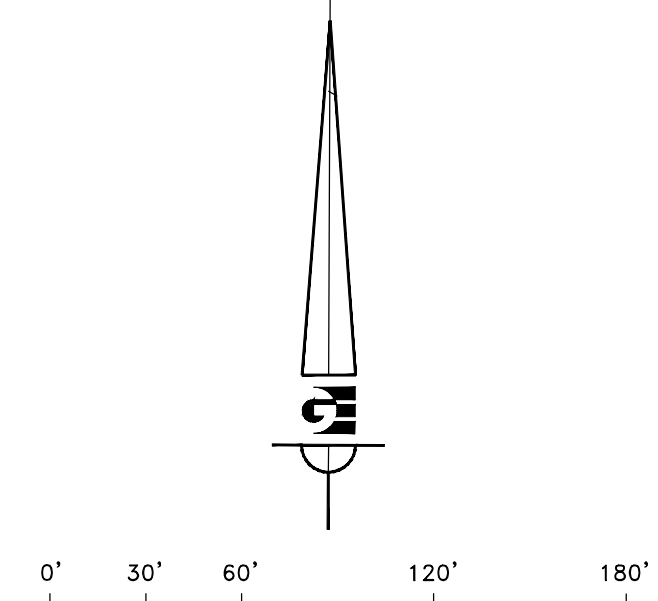

Scale in Feet
1" = 60'
LEGEND

- ◆ WEBER COUNTY MONUMENT AS NOTED
- SET 24" REBAR AND CAP MARKED GARDNER ENGINEERING
- ◆ STREET MONUMENT TO BE SET
- SUBDIVISION BOUNDARY
- LOT LINE
- ADJACENT PARCEL
- SECTION LINE
- - - BUILDING SETBACK LINE
- - - EASEMENT
- - - EXISTING FENCE

CURVE #	LENGTH	RADIUS	DELTA	CHORD BEARING	CHORD LENGTH
C1	184.07	500.00	21.09	S13° 02' 25" W	183.04
C2	198.09	500.00	22.70	S12° 14' 15" W	196.79
C3	63.46	1000.00	3.64	N89° 04' 11" E	63.45
C4	63.33	1030.00	3.52	N89° 07' 35" E	63.32
C6	58.78	530.00	6.35	N4° 03' 54" E	58.75
C7	31.69	470.00	3.86	N21° 39' 19" E	31.69
C8	151.19	530.00	16.34	N15° 24' 53" E	150.68
C9	149.74	470.00	18.25	N10° 35' 47" E	149.10
C10	157.00	530.00	16.97	N11° 53' 02" E	156.42
C11	126.51	470.00	15.42	N15° 52' 34" E	126.13
C12	29.76	530.00	3.22	N21° 58' 43" E	29.75
C13	63.59	970.00	3.76	S89° 00' 35" W	63.58
C14	59.70	470.00	7.28	N4° 31' 35" E	59.66

NOTES

- SUBJECT PROPERTY FALLS WITHIN FEMA FLOOD ZONE "X" - AREAS DETERMINED TO BE OUTSIDE THE 0.2% ANNUAL CHANCE FLOODPLAIN. PER MAP NO. 49057C0401E WITH EFFECTIVE DATE OF DECEMBER 16, 2005.
- ZONE RE-20 YARD SETBACKS: 30' FRONT // 30' REAR // 10' SIDE WITH 24' COMBINED SIDEYARD
- HOMEOWNERS ARE REFERRED TO THE GEOTECHNICAL STUDY PREPARED FOR THE SUNCREST MEADOWS SUBDIVISION BY CMT ENGINEERING LABORATORIES DATED MARCH 27, 2018 CMT PROJECT NO. 10830. SUBDIVISION IMPROVEMENTS AND HOMEOWNERS ARE REQUIRED TO COMPLY WITH SAID STUDY. ACCORDING TO THE GEOTECHNICAL REPORT, ANY NON-ENGINEERED FILL NEEDS TO BE REMOVED UNDERNEATH ANY BUILDING STRUCTURE. IT IS RECOMMENDED THAT THE GEOTECHNICAL ENGINEER OBSERVE THE EXCAVATION FOR THE HOMES IN ORDER TO VERIFY THAT THE NON-ENGINEERED FILL HAS BEEN REMOVED.
- 10' WIDE PUBLIC UTILITY AND DRAINAGE EASEMENTS EACH SIDE OF PROPERTY LINES AS INDICATED BY DASHED LINES UNLESS NOTED OTHERWISE. AGRICULTURE IS THE PREFERRED USE IN THE AGRICULTURE ZONES. AGRICULTURE OPERATIONS AS SPECIFIED IN THE ZONING ORDINANCE FOR A PARTICULAR ZONE ARE PERMITTED AT ANY TIME INCLUDING THE OPERATION OF FARM MACHINERY AND NO ALLOWED AGRICULTURE USE SHALL BE SUBJECT TO RESTRICTION ON THAT IT INTERFERES WITH ACTIVITIES OF FUTURE RESIDENTS OF THIS SUBDIVISION.

NARRATIVE

THE PURPOSE OF THIS SURVEY WAS TO CREATE A NINE LOT SUBDIVISION ON THE PROPERTY AS SHOWN AND DESCRIBED HEREON. THE SURVEY WAS ORDERED BY BLACKBURN JONES. THE CONTROL USED TO ESTABLISH THE BOUNDARY WAS THE EXISTING WEBER COUNTY SURVEY MONUMENTATION AS SHOWN AND NOTED HEREON. THE BASIS OF BEARING IS THE NORTH LINE OF THE NORTHEAST QUARTER OF SECTION 16, TOWNSHIP 6 NORTH, RANGE 2 WEST, OF THE SALT LAKE BASE AND MERIDIAN WHICH BEARS NORTH 89°26'19" WEST WEBER COUNTY, UTAH NORTH, NAD 83 STATE PLANE GRID BEARING. WARRANTY DEEDS RECORDED AS ENTRY NUMBERS 2936519, 2936521 AND DEEDS A ADJOINING PROPERTIES. THE DEDICATED PLATS OF SUNCREST MEADOWS SUBDIVISION PHASE 1 AND 2 WERE ALSO USED TO DETERMINE THE BOUNDARY.

SURVEYOR'S CERTIFICATE

I, KLINT H. WHITNEY, DO HEREBY CERTIFY THAT I AM A LICENSED PROFESSIONAL LAND SURVEYOR IN THE STATE OF UTAH AND THAT I HOLD CERTIFICATE NO. 8227228 IN ACCORDANCE WITH TITLE 58, CHAPTER 22, OF THE PROFESSIONAL ENGINEERS AND LAND SURVEYORS ACT; I FURTHER CERTIFY THAT BY AUTHORITY OF THE OWNERS I HAVE COMPLETED A SURVEY OF THE PROPERTY AS SHOWN AND DESCRIBED ON THIS PLAT, AND HAVE SUBDIVIDED SAID PROPERTY INTO LOTS AND STREETS, TOGETHER WITH EASEMENTS, HEREAFTER TO BE KNOWN AS SUNCREST MEADOWS SUBDIVISION - PH3 IN ACCORDANCE WITH SECTION 17-23-17 AND HAVE VERIFIED ALL MEASUREMENTS; THAT THE REFERENCE MONUMENTS SHOWN HEREON ARE LOCATED AS INDICATED AND ARE SUFFICIENT TO RETRACE OR REESTABLISH THIS SURVEY; THAT ALL LOTS MEET THE REQUIREMENTS OF THE LAND USE CODE; AND THAT THE INFORMATION SHOWN HEREIN IS SUFFICIENT TO ACCURATELY ESTABLISH THE LATERAL BOUNDARIES OF THE HEREIN DESCRIBED TRACT OF REAL PROPERTY.

SIGNED THIS _____ DAY OF _____, 2021.



OWNER'S DEDICATION

I THE UNDERSIGNED OWNER OF THE HEREON DESCRIBED TRACT OF LAND, HEREBY SET APART AND SUBDIVIDE THE SAME INTO LOTS, PARCELS AND STREETS AS SHOWN ON THIS PLAT AND NAME SAID TRACT:

SUNCREST MEADOWS SUBDIVISION PHASE 3

AND HEREBY DEDICATE, GRANT AND CONVEY TO WEBER COUNTY, UTAH ALL THOSE PARTS OR PORTIONS OF SAID TRACT OF LAND DESIGNATED AS STREETS, THE SAME TO BE USED AS PUBLIC THOROUGHFARES FOREVER, AND ALSO GRANT AND DEDICATE A PERPETUAL EASEMENT OVER, UPON AND UNDER THE LANDS DESIGNATED ON THE PLAT AS PUBLIC UTILITY, THE SAME TO BE USED FOR THE INSTALLATION, MAINTENANCE AND OPERATION OF PUBLIC UTILITY SERVICE LINES, STORM DRAINAGE FACILITIES OR FOR THE PERPETUAL PRESERVATION OF WATER DRAINAGE CHANNELS IN THEIR NATURAL STATE WHICHEVER IS APPLICABLE AS MAY BE AUTHORIZED BY WEBER COUNTY, UTAH, WITH NO BUILDINGS OR STRUCTURES BEING ERIGED WITHIN SUCH EASEMENTS.

SIGNED THIS _____ DAY OF _____, 2021

SUNCREST MEADOWS - WEBER, LLC BY:
BLACKBURN JONES REAL ESTATE INCORPORATED, MANAGER OF SUNCREST MEADOWS - WEBER, LLC

CARSON E. JONES, DIRECTOR OF BLACKBURN JONES REAL ESTATE INCORPORATED

ACKNOWLEDGEMENT

STATE OF UTAH)
COUNTY OF WEBER)

On this _____ day of _____, 2021, personally appeared before me CARSON E. JONES, whose identity is personally known to me (or proven on the basis of satisfactory evidence) and who by me duly sworn/affirmed, did say that he/she is the DIRECTOR OF BLACKBURN JONES REAL ESTATE INCORPORATED, MANAGER OF SUNCREST MEADOWS - WEBER, LLC, and that said document was signed by him/her in behalf of said Corporation by Authority of its Bylaws, or (Resolution of its Board of Directors), and said CARSON E. JONES acknowledged to me that said Corporation executed the same.

STAMP _____ NOTARY PUBLIC _____

<p>WEBER COUNTY SURVEYOR</p> <p>I HEREBY CERTIFY THAT THE WEBER COUNTY SURVEYOR'S OFFICE HAS REVIEWED THIS PLAT FOR MATHEMATICAL CORRECTNESS, SECTION CORNER DATA, AND FOR HARMONY WITH LINES AND MONUMENTS ON RECORD IN COUNTY OFFICES. THE APPROVAL OF THIS PLAT BY THE WEBER COUNTY SURVEYOR DOES NOT RELIEVE THE LICENSED LAND SURVEYOR WHO EXECUTED THIS PLAT FROM THE RESPONSIBILITIES AND/OR LIABILITIES ASSOCIATED THEREWITH.</p> <p>SIGNED THIS _____ DAY OF _____, 2021.</p> <p>_____ COUNTY SURVEYOR</p>	<p>WEBER COUNTY ATTORNEY</p> <p>I HAVE EXAMINED THE FINANCIAL GUARANTEE AND OTHER DOCUMENTS ASSOCIATED WITH THIS SUBDIVISION PLAT AND IN MY OPINION THEY CONFORM WITH THE COUNTY ORDINANCE APPLICABLE THERETO AND NOW IN FORCE AND EFFECT.</p> <p>SIGNED THIS _____ DAY OF _____, 2021.</p> <p>_____ COUNTY ATTORNEY</p>	<p>WEBER COUNTY ENGINEER</p> <p>I HEREBY CERTIFY THAT THE REQUIRED PUBLIC IMPROVEMENT STANDARDS AND DRAWINGS FOR THIS SUBDIVISION CONFORM WITH COUNTY STANDARDS AND THE AMOUNT OF THE FINANCIAL GUARANTEE IS SUFFICIENT FOR THE INSTALLATION OF THESE IMPROVEMENTS.</p> <p>SIGNED THIS _____ DAY OF _____, 2021.</p> <p>_____ COUNTY ENGINEER</p>	<p>WEBER COUNTY COMMISSION ACCEPTANCE</p> <p>THIS IS TO CERTIFY THAT THIS SUBDIVISION PLAT, THE DEDICATION OF STREETS AND OTHER PUBLIC WAYS AND FINANCIAL GUARANTEE OF PUBLIC IMPROVEMENTS ASSOCIATED WITH THIS SUBDIVISION THEREON ARE HEREBY APPROVED AND ACCEPTED BY THE COMMISSIONERS OF WEBER COUNTY, UTAH.</p> <p>SIGNED THIS _____ DAY OF _____, 2021.</p> <p>_____ CHAIRMAN, WEBER COUNTY COMMISSION</p>	<p>WEBER COUNTY PLANNING COMMISSION APPROVAL</p> <p>THIS IS TO CERTIFY THAT THIS SUBDIVISION WAS DULY APPROVED BY THE WEBER COUNTY PLANNING COMMISSION.</p> <p>SIGNED THIS _____ DAY OF _____, 2021.</p> <p>_____ CHAIRMAN, WEBER COUNTY PLANNING COMMISSION</p>	<p>WEBER - MORGAN HEALTH DEPARTMENT</p> <p>I DO HEREBY CERTIFY THAT THE SOILS, PERCOLATION RATES, AND SITE CONDITION FOR THIS SUBDIVISION HAVE BEEN INVESTIGATED BY THIS OFFICE AND ARE APPROVED FOR ON-SITE WASTEWATER DISPOSAL SYSTEMS.</p> <p>SIGNED THIS _____ DAY OF _____, 2021.</p> <p>_____ DIRECTOR WEBER-MORGAN HEALTH DEPT.</p>
--	---	--	---	---	---

<p>DEVELOPER: BLACKBURN JONES CARSON JONES 905 24TH STREET OGDEN, UTAH 84404 (801) 778-0088</p>	<p>S1 1</p>	<p>COUNTY RECORDER</p> <p>ENTRY NO. _____ FEE PAID _____</p> <p>FILED FOR AND RECORDED _____</p> <p>AT _____ IN BOOK _____ OF OFFICIAL _____</p> <p>RECORDS, PAGE _____, RECORDED _____</p> <p>FOR _____</p> <p>COUNTY RECORDER _____</p> <p>BY: _____</p>
<p>GARDNER ENGINEERING</p> <p>CIVIL - LAND PLANNING MUNICIPAL - LAND SURVEYING</p> <p>5150 SOUTH 375 EAST OGDEN, UT OFFICE: 801.476.0202 FAX: 801.476.0066</p>		