



Land Use Permit

Weber County Planning Commission

2380 Washington Blvd. STE 240

Ogden, UT 84401

Phone: (801) 399-8791 FAX: (801) 399-8862

webercountyutah.gov/planning

Permit Number: LUP278-2021

Permit Type: Structure

Permit Date: 08/11/2021

Applicant

Name: Derrick Oman
Business:
Address: 525 N 5500 W
Ogden, UT 84404
Phone: 801-430-1263

Owner

Name: Same as applicant
Business:
Address: , UT
Phone:

Parcel

Parcel: 150240004

Zoning: A-2 **Area:** 11.2 **Sq Ft:**

Address: , UT

Lot(s):

Subdivision:

T - R - S - QS: 6N - 2W - 07 -

Proposal

Proposed Structure: Ag exempt no animals

Proposed Structure Height: 26

of Dwelling Units: 0

Off Street Parking Req'd: 0

Building Footprint: 3840

Max Structure Height in Zone: 35

of Accessory Bldgs: 0

***Is Structure > 1,000 Sq. Ft?** N/A

*If True Need Certif. Statement

Permit Checklist

Access Type: Across front lot line

Greater than 4218 ft above sea level? N/A

Additional Setback Req'd. ? N/A

> 200 ft from paved Road? N/A

Culinary Water District: N/A

Alternative Access File #

Wetlands/Flood Zone? N/A

Meet Zone Area Frontage? N/A

Hillside Review Req'd? N/A

Waste Water System: N/A

Comments

The project will need to be no closer than 100 feet to the high water mark of the Weber River.

Land Use Permit

Structure Setback Graphic: Barn, Corral, or Stable

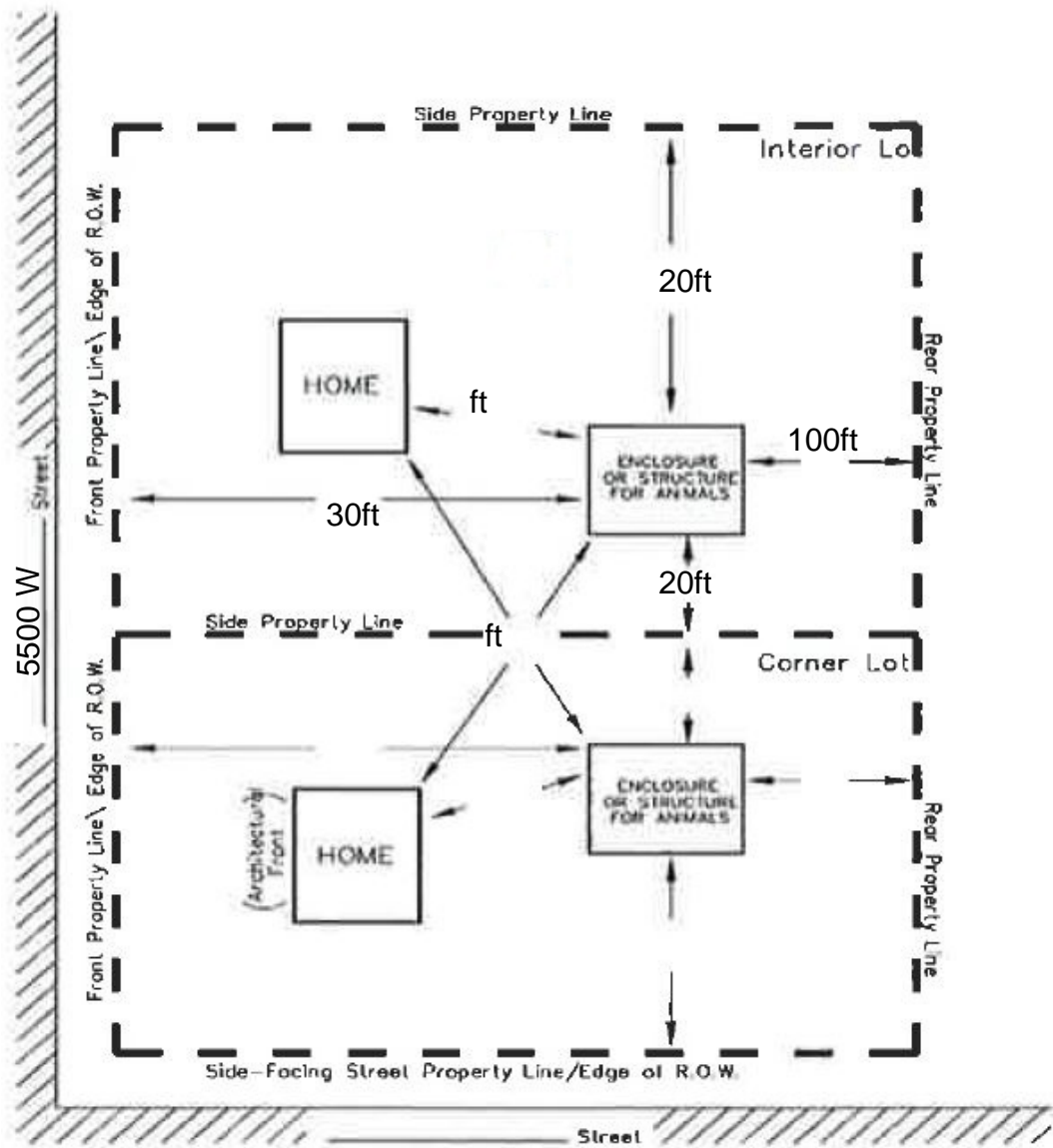

MINIMUM YARD SETBACKS Barn, Corral, or Stable

NOTICE FOR APPLICANT (Please Read Before Signing)

Proposals for the installation of an individual water supply and for a sanitary waste disposal system (septic tank) for any structure designed for human occupation must be approved by Weber County Health Department prior to installation.

Steven Burton

08/11/2021

Planning Dept. Signature of Approval

Date

I hereby certify that I have read and examined this application and know the same to be true and correct. All provisions of laws and ordinances governing this land use will be complied with whether specified herein or not. I make this statement under penalty of perjury.

Contractor/Owner Signature of Approval

Date