



Land Use Permit

Weber County Planning Commission

2380 Washington Blvd. STE 240

Ogden, UT 84401

Phone: (801) 399-8791 FAX: (801) 399-8862

webercountyutah.gov/planning

Permit Number: LUP95-2021

Permit Type: Structure

Permit Date: 03/26/2021

Applicant

Name: Casey Gauchat

Business:

Address:

, UT

Phone: 8017919413

Owner

Name: Paul Gauchat

Business:

Address: 815 S 8600 E

Eden, UT 84310

Phone:

Parcel

Parcel: 210260062

Zoning: FV-3 **Area:** 2.45 **Sq Ft:**

Lot(s):

Subdivision:

Address: 815 S 8600 E HUNTSVILLE, UT 84317

T - R - S - QS: 6N - 2E - 17 - SE

Proposal

Proposed Structure: Ag Bldg

Building Footprint: 3456

Proposed Structure Height: 22

Max Structure Height in Zone: 25

of Dwelling Units: 1

of Accessory Bldgs: 2

Off Street Parking Reqd:

***Is Structure > 1,000 Sq. Ft?** Yes

*If True Need Certif. Statement

Permit Checklist

Access Type: Public Own Front

Alternative Access File #

Greater than 4218 ft above sea level? Yes

Wetlands/Flood Zone? No

Additional Setback Reqd. ? No

Meet Zone Area Frontage? Yes

> 200 ft from paved Road? No

Hillside Review Reqd? No

Culinary Water District:

Waste Water System:

Comments

Land use requirements are met for an agricultural exempt structure to be built in place of one that was destroyed in a fire.

Land Use Permit

Structure Setback Graphic: Barn, Corral, or Stable

****See additional notes in the comments section****

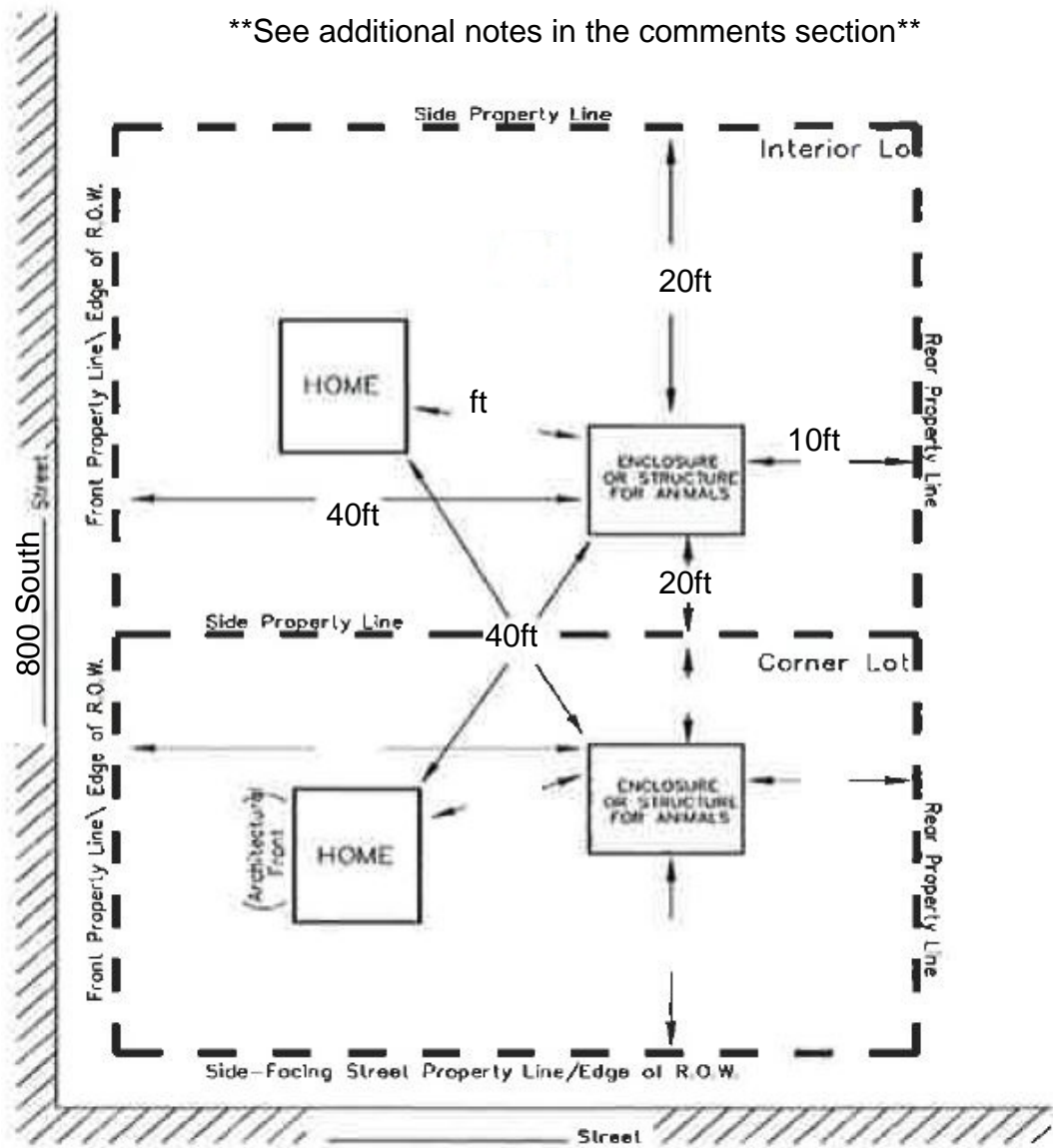

MINIMUM YARD SETBACKS Barn, Corral, or Stable

NOTICE FOR APPLICANT (Please Read Before Signing)

Proposals for the installation of an individual water supply and for a sanitary waste disposal system (septic tank) for any structure designed for human occupation must be approved by Weber County Health Department prior to installation.

Felix Lleverino

03/26/2021

Planning Dept. Signature of Approval

Date

I hereby certify that I have read and examined this application and know the same to be true and correct. All provisions of laws and ordinances governing this land use will be complied with whether specified herein or not. I make this statement under penalty of perjury.

Contractor/Owner Signature of Approval

Date