

### PROJECT DATA TABLE

PARCEL ID #: 10-037-0044

<b>OVERALL PROJECT AREA</b>	<b>83,663 S.F.</b>
<b>BUILDING FOOTPRINT</b>	<b>19,721 S.F.</b>
<b>CONCRETE</b>	<b>1,775 S.F.</b>
<b>ASPHALT PAVEMENT</b>	<b>13,229 S.F.</b>
<b>COMPACTED ROAD BASE</b>	<b>35,939 S.F.</b>
<b>LANDSCAPING</b>	<b>12,998 S.F.</b>

<b>PARKING REQUIRED</b>	
<b>EMPLOYEES</b>	<b>16</b>
<b>VISITORS</b>	<b>2</b>
<b>TOTAL STALLS REQUIRED</b>	<b>18</b>

<b>PARKING PROVIDED</b>	
<b>ADA ACCESSIBLE STALLS</b>	<b>1</b>
<b>STANDARD PARKING STALLS</b>	<b>20</b>
<b>TOTAL STALLS PROVIDED</b>	<b>21</b>

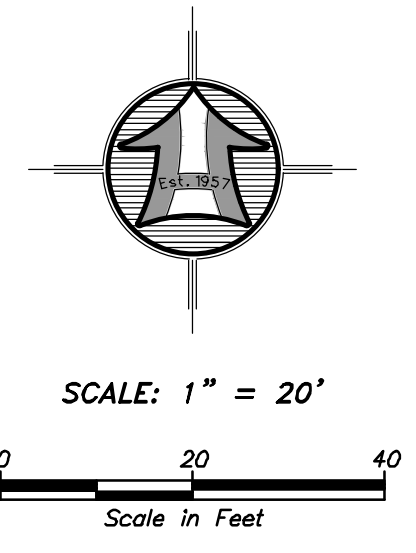

### Legend

	Subject Property Line		Proposed Asphalt Pavement
	Secondary Property Line		Proposed Concrete
	Centerline		Proposed Landscape
	Easement/Right-of-Way Line		Proposed Road Base Surface
	Section Line		Edge of Asphalt
	Existing 5.0' Contour		Edge of Gravel/Road Base
	Existing 1.0' Contour		Proposed Septic Field
	Existing Edge of Asphalt		Sewer Manhole
	Water Line Existing		Power Pole
	Sewer Line Existing		Telephone Pedestal
	Power Line Existing		
	Telephone Line Existing		
	Gas Line Existing		
	Fiber Optic Line Existing		
	Fire Hydrant		
	Water Meter		
	Water Valve		

<b>HANSEN &amp; ASSOCIATES, INC.</b> Consulting Engineers and Land Surveyors 538 North Main Street, Brigham, Utah 84302 Visit us at <a href="http://www.hansen.net">www.hansen.net</a> Ogden, Utah (435) 752-4272 (801) 399-4491 Celebrating over 60 Years of Business	<b>HW</b> HANSEN & ASSOCIATES, INC. Consulting Engineers and Land Surveyors 538 North Main Street, Brigham, Utah 84302 Visit us at <a href="http://www.hansen.net">www.hansen.net</a> Ogden, Utah (435) 752-4272 (801) 399-4491 Celebrating over 60 Years of Business
Drawn By: BTC Designed By: Checked By: Approved By: Scale: 1" = 40' Drawing File: 20-5-48 sp 100920 JOB NUMBER: 20-5-48	Date: 12/04/20 No. _____ Date _____ By _____ Revision _____
<b>SITE PLAN FOR</b> <b>BOWEN FABRICATION</b> 900 SOUTH 7900 WEST WEBER COUNTY, UT	
Sheet <b>1</b> of <b>1</b> Sheets	