

SYMMETRY IGD SPECIFICATIONS

GENERAL:

- PIT DEPTH: 8"
- TRAVEL: 144" (MINIMUM 12" BETWEEN STOPS)
- OVERHEAD: 96"
- 40 FPM
- CAPACITY: 1000#
- CAR/FRAME WEIGHT: 895#
- STOPS: 2
- 90° CONFIGURATION
- HOISTWAY SWING DOORS BY OTHERS

CAR FEATURES:

- 40" X 54" CAR SIZE
- 7' - 0" INTERIOR CAR HEIGHT
- UNFINISHED BIRCH FLAT PANEL INTERIOR WALLS WITH FLAT PANEL CEILING
- (1) FLAT MATCHING WOOD HANDRAIL
- MATCHING WOOD CAR SILLS
- UNFINISHED 3/4" PLWOOD FLOOR SET FOR 3/4" FLOORING (BY OTHERS)
- (2) ENERGY SAVING RECESSED LED LIGHTS WITH BLACK TRIM RINGS
- (1) 7' - 0", 33" CLEAR, BLACK SYMMETRY SAFETY 3 PANEL CAR DOORS WITH 3 VISION PANELS, RIGHT HAND
- (1) 7' - 0", 33" CLEAR, BLACK SYMMETRY SAFETY 3 PANEL CAR DOORS WITH 3 VISION PANELS, LEFT HAND

FIXTURES:

- BRUSHED STAINLESS CAR OPERATING PANEL (COP) WITH LED FLOOR POSITION INDICATOR
- BRUSHED STAINLESS RECESSED PHONE BOX (PHONE JACK INCLUDED)
- (2) BRUSHED STAINLESS HALL STATIONS WITH CALL BUTTON AND POSITION INDICATOR

MECHANICAL EQUIPMENT:

- COUNTERWEIGHTED CHAIN DRIVE
- MODULAR 6 1/4" T-RAIL STRUCTURE
- UNDERSLUNG CAR FRAME ASSEMBLY
- ADJUSTABLE RAIL BRACKETS
- 208/230 VAC, 60HZ, 20 AMP SINGLE PHASE POWER SUPPLY FOR MOTOR CONTROLLER
- 120 VAC, 60HZ, 15 AMP SINGLE PHASE POWER SUPPLY FOR CAR LIGHTING
- (2) #60 ROLLER CHAINS (9,920# AVERAGE BREAKING STRENGTH EACH)
- CODE COMPLIANT ELECTRICAL DISCONNECTS
- SYMMETRY ELEVATING SOLUTIONS INVERTER CONTROLLED VARIABLE SPEED 2HP IN-LINE GEARED DRIVE ASSEMBLY

SAFETY DEVICES: (2013 & PRIOR)

- SLACK CHAIN SAFETY DEVICE - TYPE "A" INSTANTANEOUS (SYMMETRY ELEVATING SOLUTIONS MODEL SSD-01)
- INTEGRAL MOTOR CONTROLLER SUPPLY DISCONNECT
- INTEGRAL CAR LIGHT SUPPLY DISCONNECT
- (2) UPPER AND (1) LOWER FINAL LIMITS
- MACHINE STOP SWITCH
- PIT STOP SWITCH
- CARTOP STOP SWITCH
- IN-CAR EMERGENCY STOP SWITCH AND ALARM
- SAFETY SWITCH FOR CAR GATE/DOOR(S)
- BATTERY BACKUP EMERGENCY CAR LIGHT AND ALARM
- (1) RH AND (1) LH ELECTROMECHANICAL HOISTWAY DOOR LOCKING DEVICES DOORS BY OTHERS)

CONTROLS: REMOTE CONTROLLER

- PROGRAMMABLE LOGIC CONTROLLER (PLC)
- NON-SELECTIVE COLLECTIVE AUTOMATIC OPERATION
- SELF DIAGNOSTIC SYSTEM WITH DIGITAL DISPLAY
- AUTOMATIC CAR LIGHTING
- SINGLE FLOOR DESIGNATED CAR HOMING
- UNINTERRUPTIBLE POWER SUPPLY (UPS) FOR CAR LOWERING AND AUTOMATIC GATE OPERATION (IF PROVIDED) IN THE EVENT OF POWER FAILURE
- MANUAL LOWERING DEVICE

OPTIONAL INCLUDED FEATURES:

- TRIMLESS CAB PACKAGE

THIS UNIT IS DESIGNED AND MANUFACTURED TO MEET THE APPLICABLE REQUIREMENTS OF ASME A17.1 WHEN PROPERLY EQUIPPED AND INSTALLED.

ABLE ACCESS ELEVATOR AND LIFT

890 W CENTER ST., STE. 3 NORTH SALT LAKE, UT 84054 801-363-7960

REV	DATE	BY	NOTES
R0	07/24/20	GLA	NEW DRAWING
	/ /		
	/ /		
	/ /		
	/ /		

SPECIFICATION SHEET			SCALE N/A
DRAWN BY GLA	DATE 07/24/20	DRAWING NO. 072420-02	REV. R0
JOB INFORMATION			
ORCHARD CABIN - 5550 Hwy 39 HUNTSVILLE, UT 84317			

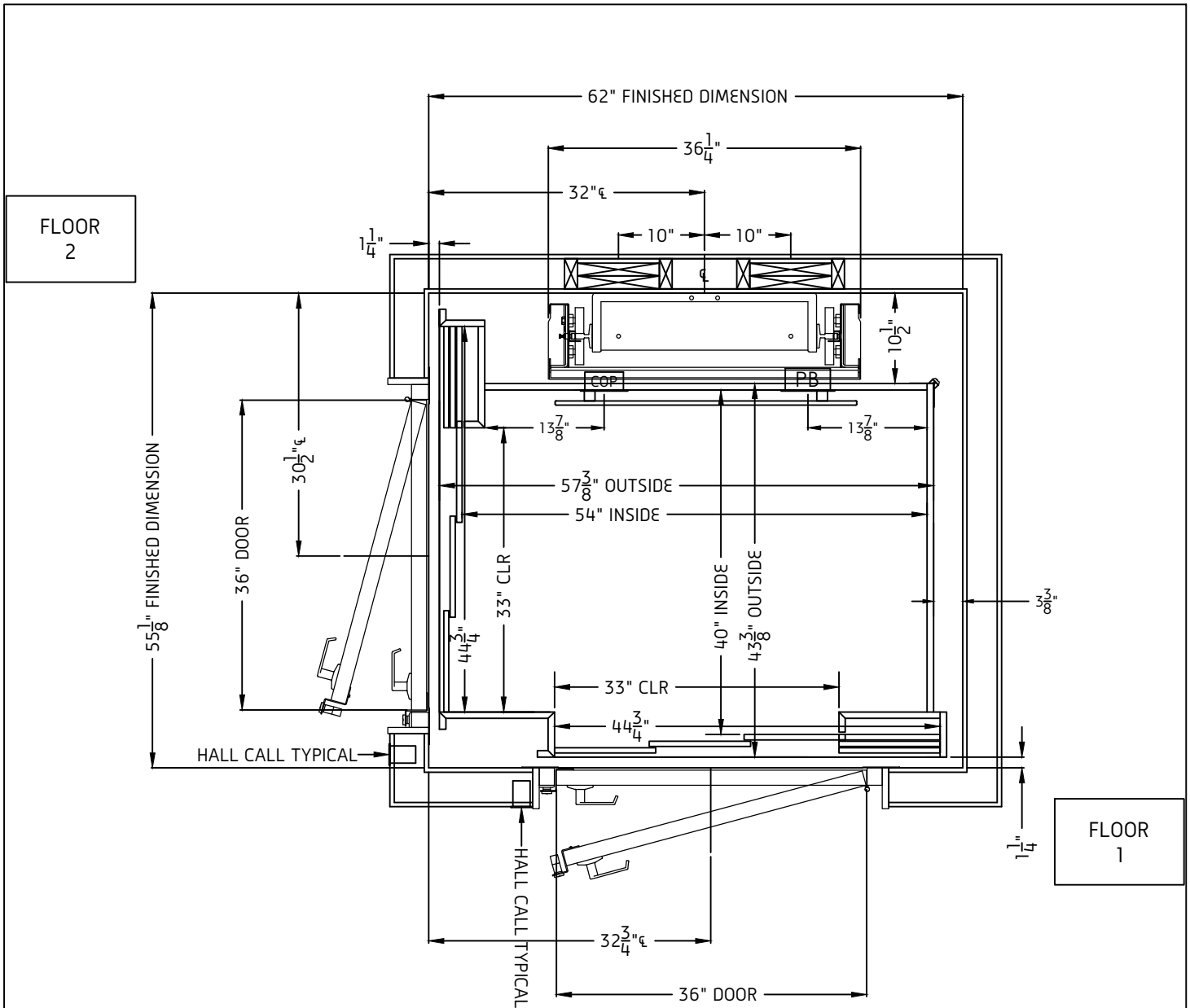

NOTES:
 CAR FLOORING AND FINISHINGS MUST NOT EXCEED 25 LBS

TYPICAL DOOR LOCATION DETAIL
 SYMMETRY SAFETY 3 PANEL CAR DOORS

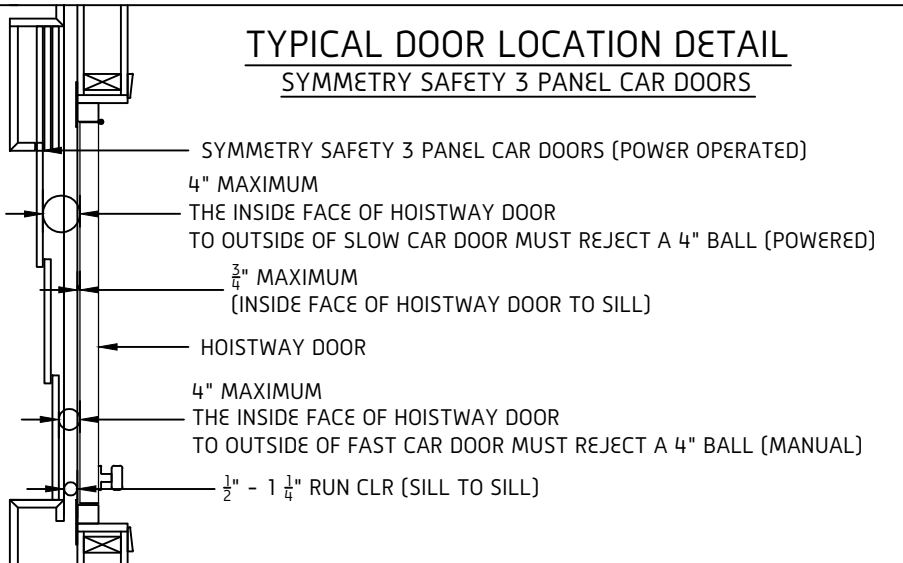

ABLE ACCESS ELEVATOR			
890 W CENTER ST #3 NORTH SALT LAKE, UT 84054 901-363-7960			
TITLE 40 X 54 90° OPENINGS RL RH LH		SCALE NONE	
DRAWN BY GLA	DATE 07/24/20	DRAWING NO. 072420-02	REV RO
JOB INFORMATION ORCHARD CABIN 5550 HWY 39 HUNTSVILLE, UT 84317			

NOTES:

- 1) CONSULT LOCAL AUTHORITY TO ENSURE COMPLIANCE WITH STATE AND LOCAL CODES.
- 2) THE HOISTWAY IS REQUIRED TO BE FREE OF ALL PIPES, WIRING, AND OBSTRUCTIONS NOT RELATED TO THE OPERATION OF THE ELEVATOR.

Travel (ft)	0'0"-15'0"	15'1"-30'0"	30'1"-50'0"
Hydro Static Load (lbs)	2552	2942	3399
Hydro Impact Load (lbs)	5277	5667	6124
Travel (ft)	0'0"-15'0"	15'1"-30'0"	30'1"-50'0"
IGD Static Load (lbs)	3082	3374	3764
IGD Impact Load (lbs)	5807	6099	6489
Travel (ft)	0'0"-15'0"	15'1"-30'0"	30'1"-50'0"
Drum Static Load (lbs)	2552	2942	3399
Drum Impact Load (lbs)	5277	5667	6124

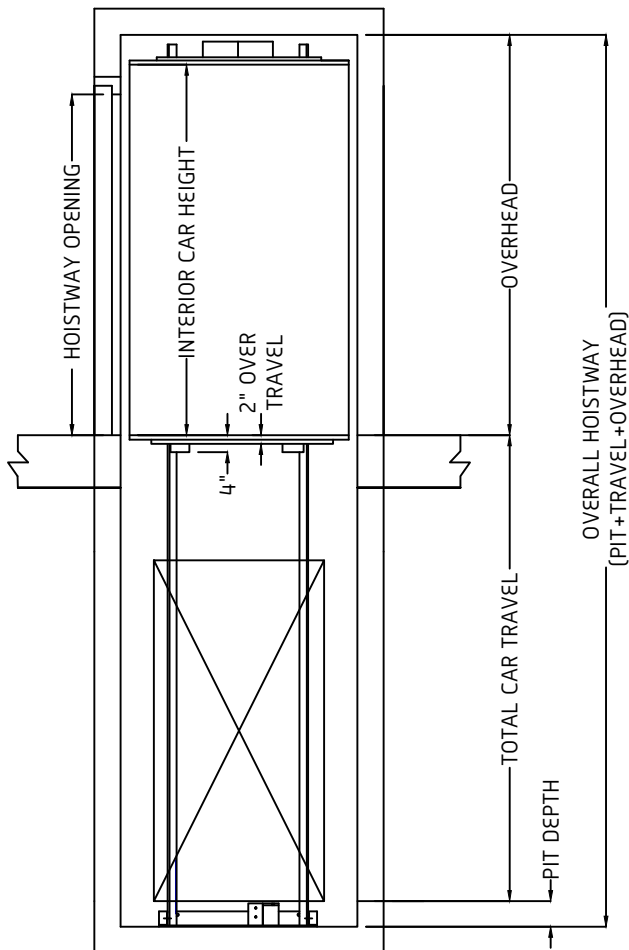

JOB SPECIFIC INFORMATION:

248"	OVERALL HOISTWAY
96"	OVERHEAD
144"	FLOOR TO FLOOR TRAVEL
8"	PIT DEPTH

ABLE ACCESS ELEVATOR			
890 W CENTER ST #3 NORTH SALT LAKE, UT 84054 901-363-7960			
TITLE 2 STOP ELEVATION		SCALE NONE	
DRAWN BY GLA	DATE 07/24/20	DRAWING NO. 072420-02	REV RO
JOB INFORMATION ORCHARD CABIN 5550 HWY 39 HUNTSVILLE, UT 84317			

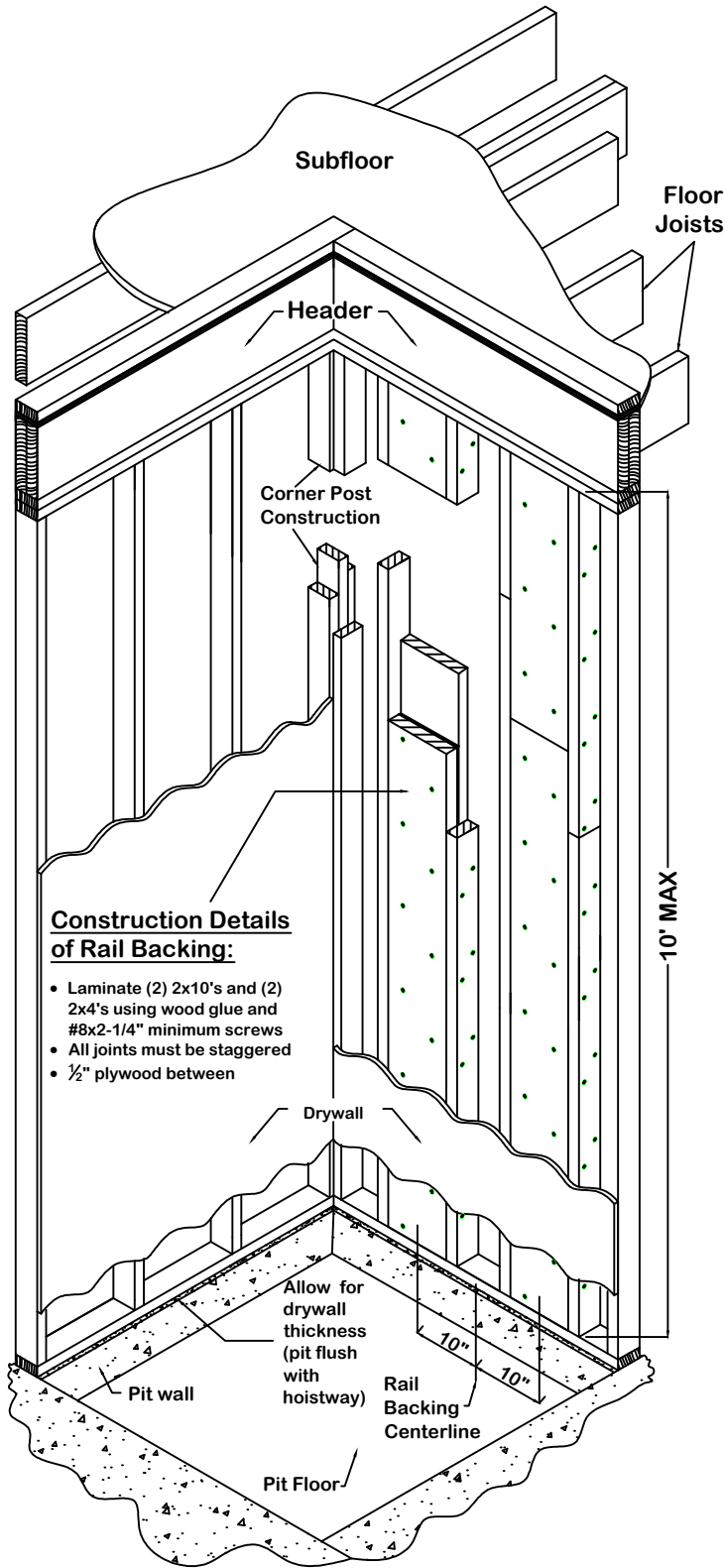

Construction Details of Rail Backing:

- Laminate (2) 2x10's and (2) 2x4's using wood glue and #8x2-1/4" minimum screws
- All joints must be staggered
- 1/2" plywood between

Typical Rail Backing Construction

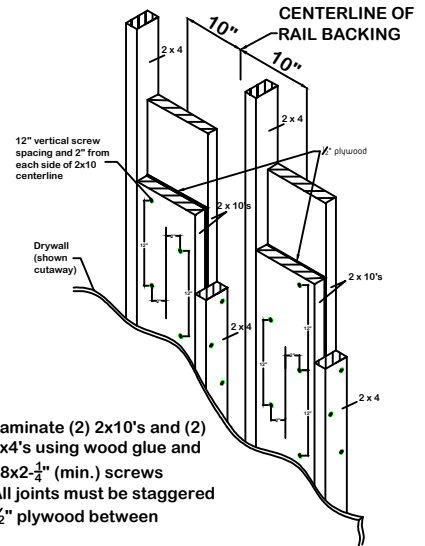

- Laminate (2) 2x10's and (2) 2x4's using wood glue and #8x2-1/4" (min.) screws
- All joints must be staggered
- 1/2" plywood between

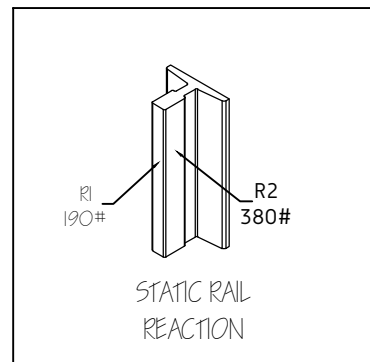

Typical Hoistway Construction Details

ABLE ACCESS ELEVATOR			
890 W CENTER ST #3 NORTH SALT LAKE, UT 84054 901-363-7960			
TITLE TYPICAL HOISTWAY CONSTRUCTION			SCALE NONE
DRAWN BY GLA	DATE 07/24/20	DRAWING NO. 072420-02	REV R0
JOB INFORMATION ORCHARD CABIN 5550 HWY 39 HUNTSVILLE, UT 84317			

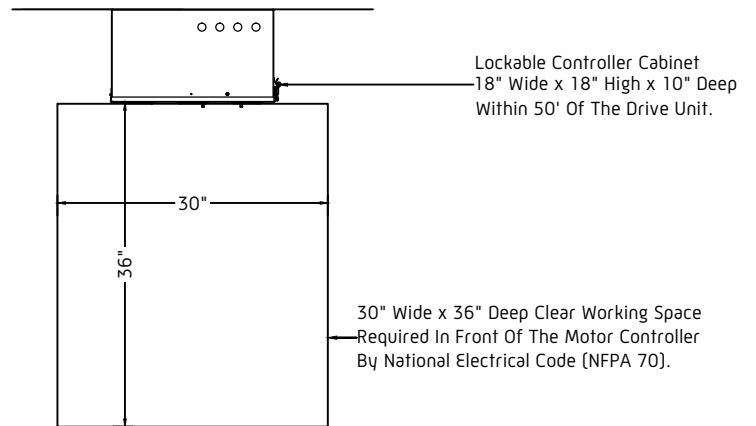
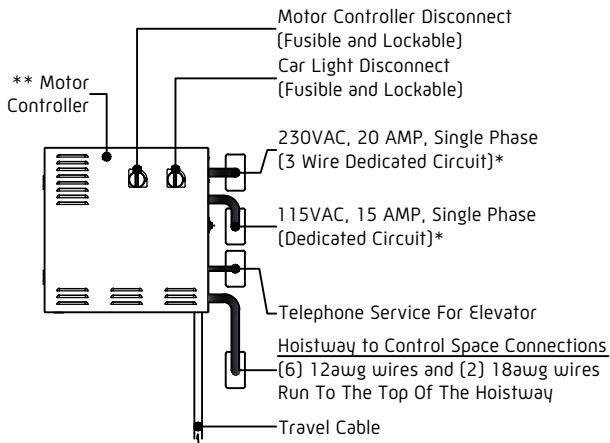
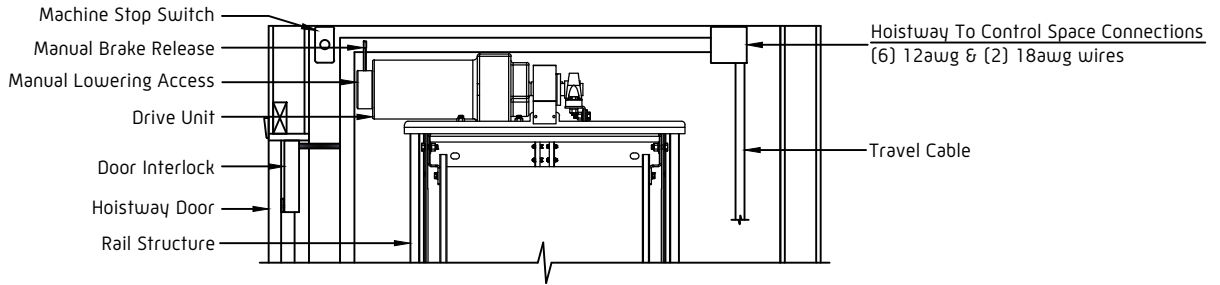
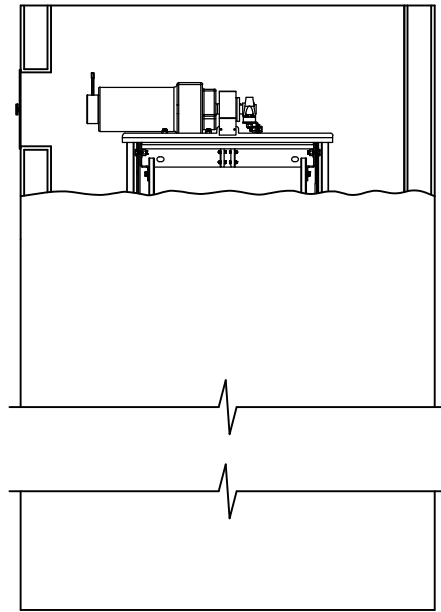
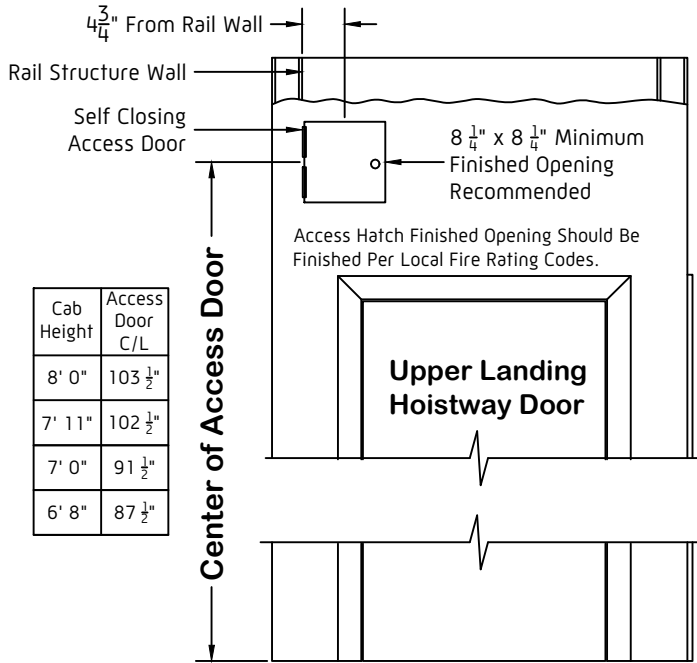

*Feeding breaker must not be a G.F.C.I.

** The control space must be maintained between 32° to 80° F.

ABLE ACCESS ELEVATOR			
890 W CENTER ST #3 NORTH SALT LAKE, UT 84054 901-363-7960			
TITLE	REMOTE CONTROL SPACE - LH MOTOR - RL		SCALE NONE
DRAWN BY	DATE	DRAWING NO.	REV
GLA	07/24/20	072420-02	RO
JOB INFORMATION			
ORCHARD CABIN			
5550 HWY 39			
HUNTSVILLE, UT 84317			

Notes

- 1) All bracket elevations are reference from the pit floor to the center of the bracket.
- 2) Each rail section shall have a minimum of one bracket.
- 3) The maximum rail section length is 10'-0"
- 4) The maximum space between brackets is 6'-0".

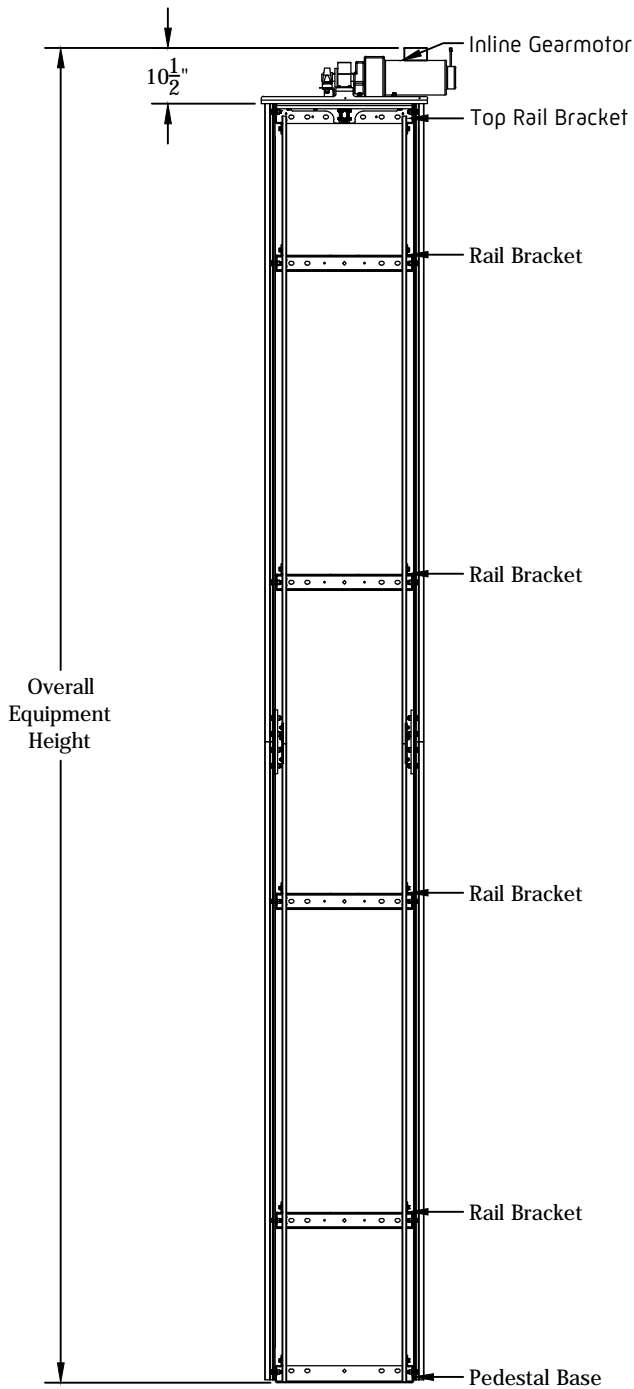

Please note that this is a typical drawing.
There may be more or less brackets than shown in this view.

Hoistway Information	
Pit Depth	8"
Floor To Floor Travel	144"
Overhead	96"
Overall Hoistway	248"

Equipment Information	
Overall Equipment Height	247-1/4"
Total Rail Height	236"

Bracket Elevations			
Top 115-1/2"	#5	Rail Bracket	226-1/2"
	#4	Rail Bracket	210-1/2"
	#3	Rail Bracket	150-1/2"
Base 120"	#2	Rail Bracket	90-1/2"
	#1	Rail Bracket	30-1/2"

Preliminary Rail Bracket Elevations Are Subject To Change If The Hoistway Information Above Changes.

ABLE ACCESS ELEVATOR			
890 W CENTER ST #3 NORTH SALT LAKE, UT 84054 901-363-7960			
TITLE RAIL BRACKET ELEVATION DRAWING			SCALE NONE
DRAWN BY GLA	DATE 07/24/20	DRAWING NO. 072420-02	REV RO
JOB INFORMATION ORCHARD CABIN 5550 HWY 39 HUNTSVILLE, UT 84317			