

DESIGN ACCORDING TO THE 2018 IBC.
FOR SPECIFICATIONS NOT SHOWN REFER TO THE 2018 IBC.

DESIGN CATEGORY:
RISK CATEGORY I – LOW RISK

SEISMIC CRITERIA:
DESIGN CATEGORY D
SOIL SITE CLASS D (ASSUMED)
R = 2.5 (LIGHT-FRAME WALLS WITH SHEAR PANELS OF ALL OTHER MATERIALS)
SS= 0.0g, S1= 0.0g; SDS= 0.0g, SD1= 0.0g
ANALYSIS PROCEDURE: EQUIVALENT LATERAL FORCE
BASE SHEAR= 000 LBS

WIND LOAD:
ULTIMATE WIND DESIGN SPEED: 105 MPH 3 SEC. GUST
(RISK CATEGORY I, 2018 IBC FIGURE 1609.3(4))
TERRAIN EXPOSURE C

SNOW LOAD:
SITE ELEVATION: 5090 FT
GROUND SNOW LOAD: 43 PSF
ROOF DESIGN SNOW LOAD: 30 PSF

DEAD LOADS:
ROOF STRUCTURE 4 PSF
WALLS 4 PSF

ROOF LIVE LOAD: 20 PSF
FROST DEPTH: 40 IN

- CONCRETE FOUNDATION NOTES:
- 28 DAY STRENGTH (F'C) W/ NORMAL 145 PCF DENSITY: FOOTINGS: 3000 PSI
 - SLABS ON GRADE: 3000 PSI REQUIRED, 3500 PSI RECOMMEND
 - ALL SLABS: PROVIDE A MIN. THICKNESS OF 4" W/ 4" DEEP MIN. CRUSHED GRAVEL BASE.
 - CONTRACTION/CONTROL JOINTS SHALL BE INSTALLED IN SLABS ON GRADE SO THE LENGTH TO WIDTH RATIO OF THE SLAB IS NO MORE THAN 1.5:1. CONTROL JOINT SPACING SHALL NOT EXCEED 30 TIMES THE SLAB THICKNESS IN ANY DIRECTION, UNLESS OTHERWISE NOTED.
 - CONTROL JOINTS SHALL BE COMPLETED WITHIN 6-18 HOURS OF CONCRETE PLACEMENT.
 - CONTROL JOINTS SHALL BE TOOLED OR SAWED TO THE GREATER DEPTH OF 1" DEEP OR 1/4 THICKNESS OF CONCRETE SLAB.

- SOILS AND EXCAVATION:
- NO SOILS REPORT PROVIDED – STABLE SOIL CHARACTERISTICS ASSUMED. ALL DESIGN WAS BASED ON STABLE SOIL CHARACTERISTICS. GEOTECHNICAL HAZARDS FOUND ON OR AROUND THE SITE, INCLUDING EXPANSIVE CLAYS, OR SOILS FOUND AT THE SITE WHILE EXCAVATION OCCURS WHICH DIFFERS FROM THOSE ASSUMED SHOULD BE BROUGHT TO THE ATTENTION OF THE BUILDING OFFICIAL AND ENGINEER.
 - ALLOWABLE BEARING PRESSURE: 1500 PSF
 - NATIVE MATERIAL SURROUNDING FOOTING TO BE DISTURBED MINIMALLY DURING EXCAVATION.
 - FOOTINGS SHALL BE PLACED ENTIRELY IN UNDISTURBED NATIVE SOILS OR STRUCTURAL FILL WHICH IS BEARING ON UNDISTURBED NATIVE SOILS AND IS COMPACTED TO 95% OF THE MODIFIED PROCTOR DENSITY.

GENERAL
11. PLEASE REFER TO THE STRUCTURAL CALCULATIONS FOR ALL SPECIFICATIONS AND DESIGN CRITERIA NOT LISTED HERE. WHERE DETAILS ARE NOT SPECIFIED, TYPICAL DETAILS AS SPECIFIED ON PLANS AND ON THE STRUCTURAL DETAILS SHEET SHALL APPLY.

BEEHIVE BUILDINGS

MIKE ROUNDY BUILDING

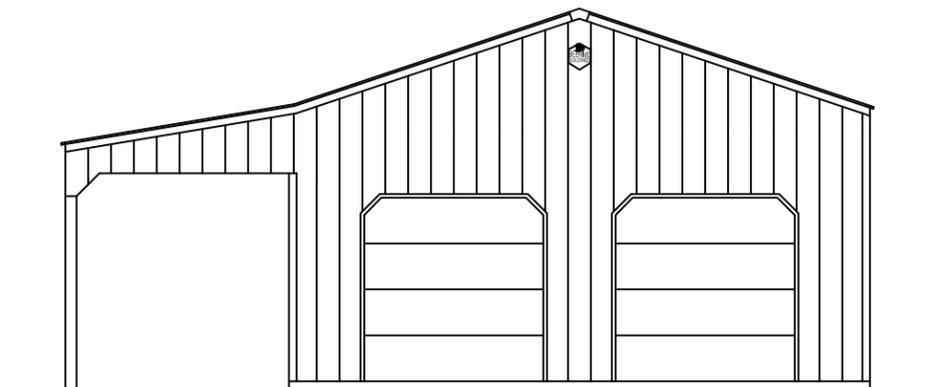

BUILDING INFORMATION

SITE INFORMATION:

ADDRESS:
559 N 5150 E
EDEN, UTAH

BUILDING INFORMATION:

DIMENSIONS: 25' x 40'
TOTAL SQUARE FOOTAGE: 1400 S.F.
MAIN BUILDING: 1000 S.F.
LEANS: 400 S.F.

CONTACTS

CONTRACTOR:

BEEHIVE BUILDINGS
CONTACT: GARRETT NICHOLS
PHONE: 801-529-4222

DRAFTING AND ENGINEERING:



CONTACT: DEREK LLOYD
DEREK@MOUNTAINPOINTENGINEERING.COM
PHONE: 801-450-5332

DRAWING INDEX

| SHEET | DESCRIPTION |
|-------|-----------------|
| 00 | COVER SHEET |
| 01 | FOUNDATION PLAN |
| 02 | FLOOR PLAN |
| 03 | ROOF PLAN |
| 04 | GIRT PLAN |
| 05 | ELEVATIONS |
| 06 | PANEL LAYOUT |
| 07 | DETAIL SHEET |
| 08 | DETAIL SHEET |
| 09 | DETAIL SHEET |

**PRELIMINARY
NOT FOR PERMIT**

ENGINEER STAMP

DATE

01/21/2020

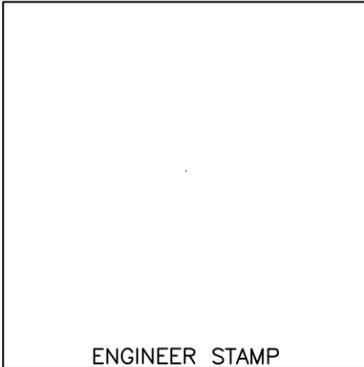

FOUNDATION PLAN

MIKE ROUNDY BUILDING
EDEN, UTAH

PROJECT
B104

SCALE
1/8" = 1'-0"

DATE
01/21/2020

SHEET
01

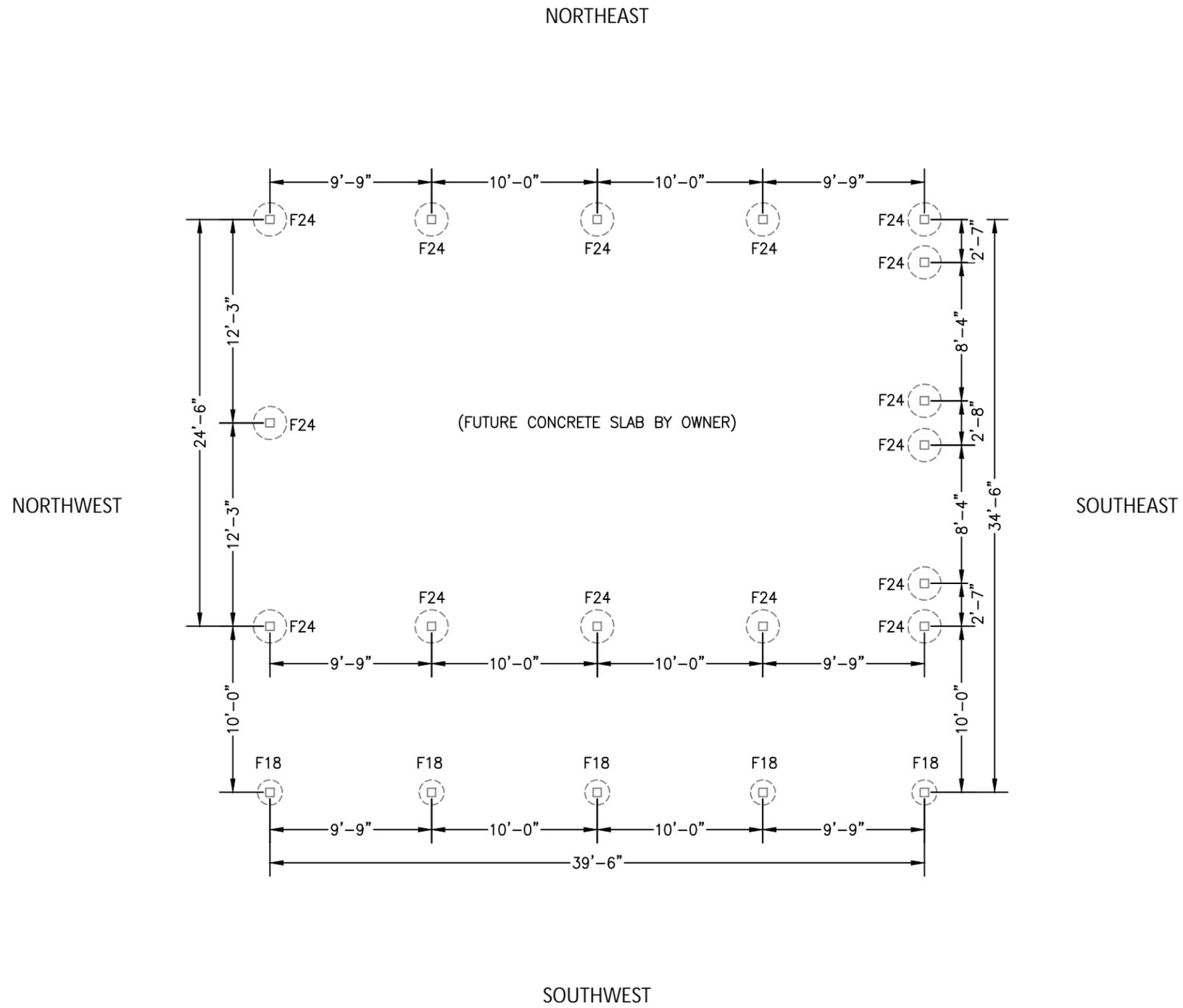

- PIERS:
1. F18: 18" DIA X 40" DEEP CONCRETE PIER
 - 1.1. 24" DIA OK
 2. F24: 24" DIA x 40" DEEP CONCRETE PIER

ENGINEER STAMP



FLOOR PLAN

MIKE ROUNDY BUILDING
EDEN, UTAH

PROJECT
B104

SCALE
1/8" = 1'-0"

DATE
01/21/2020

SHEET
02

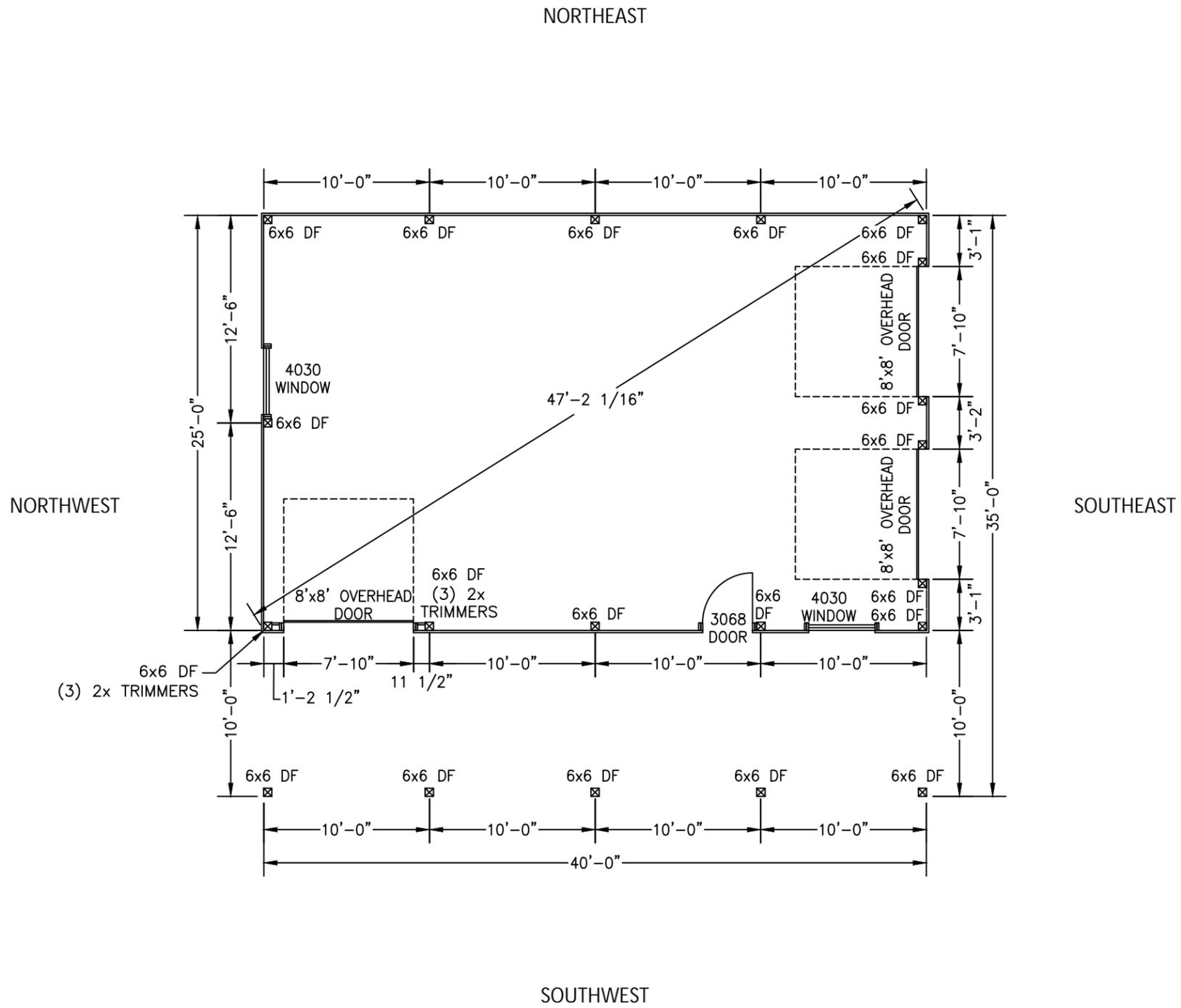

- NOTES:
1. 6x6 DF: 6x6 DF-L #2 TREATED POST.
 2. EMBED POST INTO CONCRETE PIER. SEE DETAIL ON SHEET 8.
 3. ROOF: 29 GA STEEL PANEL
 4. WALLS: STANDARD GIRTS, 29 GA STEEL PANEL

NORTHWEST

NORTHEAST

SOUTHEAST

SOUTHWEST

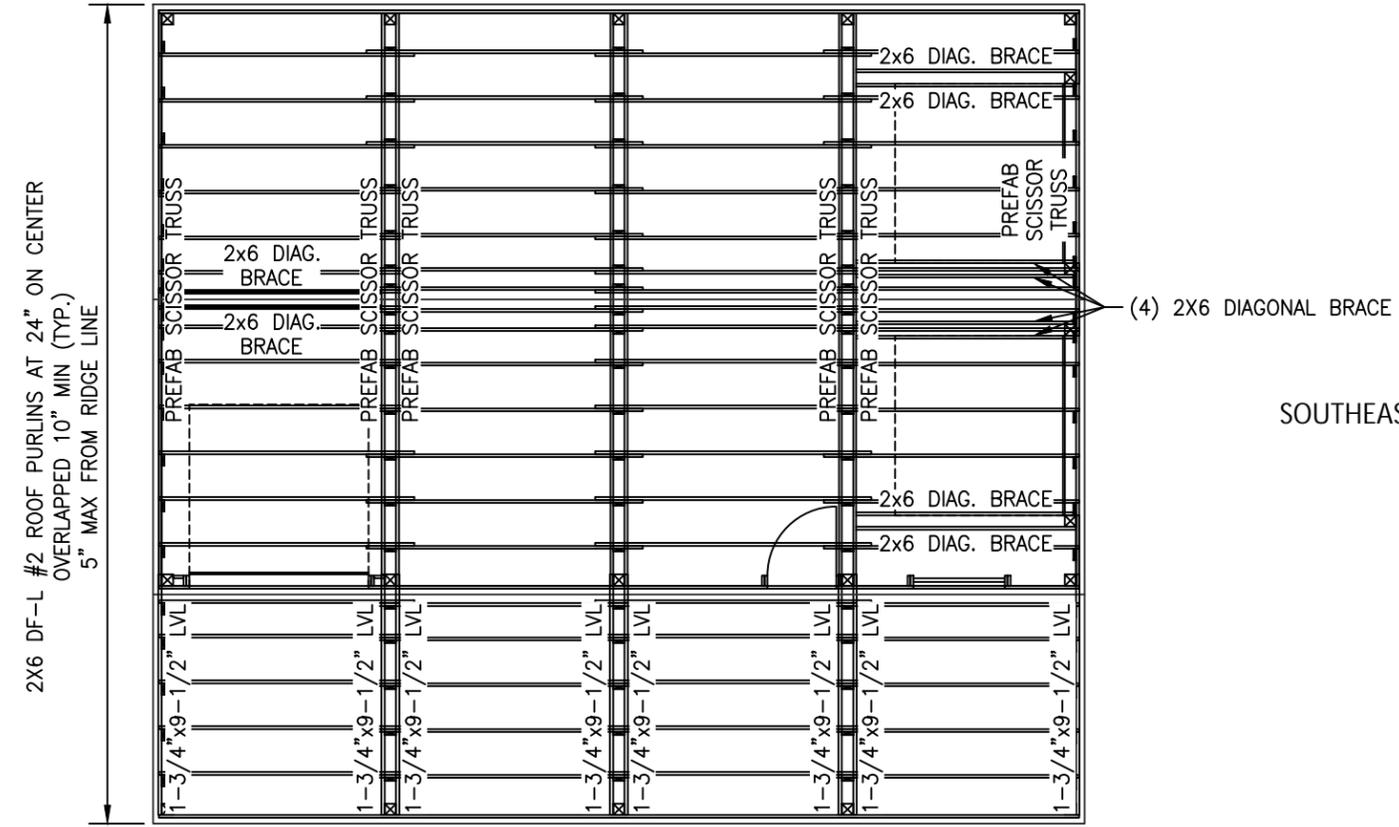

ENGINEER STAMP



ROOF FRAMING PLAN

MIKE ROUNDY BUILDING
EDEN, UTAH

- NOTES:
1. TRUSSES WILL BE DEFERRED PER IBC 107.3.4.1 AND WILL BE DESIGNED BY A LICENSED ENGINEER IN THE STATE OF UTAH.
 2. PROVIDE TRUSS BOTTOM CHORD BRACING PER TRUSS MANUFACTURER'S SPECIFICATIONS.

PROJECT
B104

SCALE
1/8" = 1'-0"

DATE
01/21/2020

SHEET
03

ENGINEER STAMP

GIRT PLAN

MIKE ROUNDY BUILDING
EDEN, UTAH

PROJECT
B104

SCALE
1/8" = 1'-0"

DATE
01/21/2020

SHEET
04

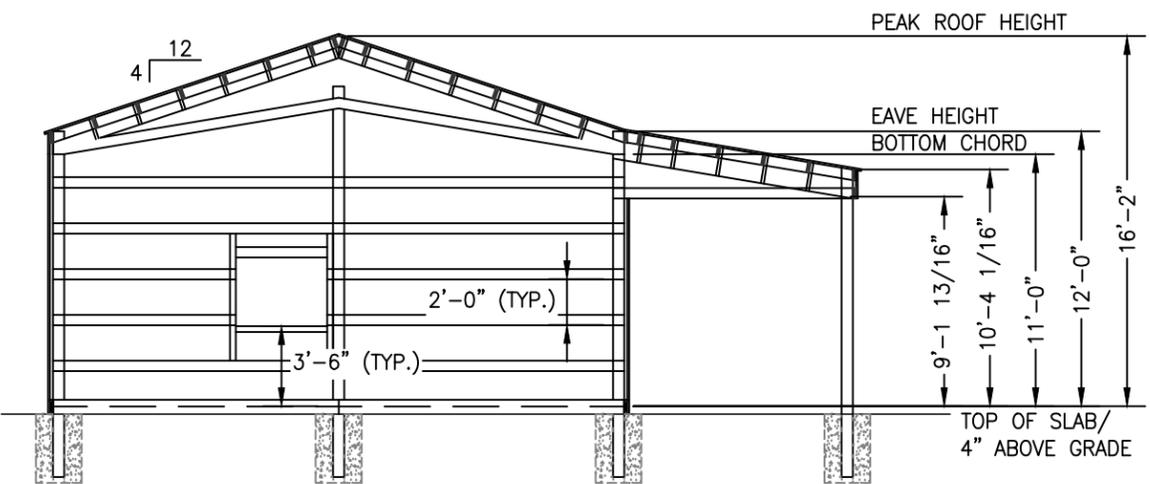

GABLE END GIRT WALL - NORTHWEST

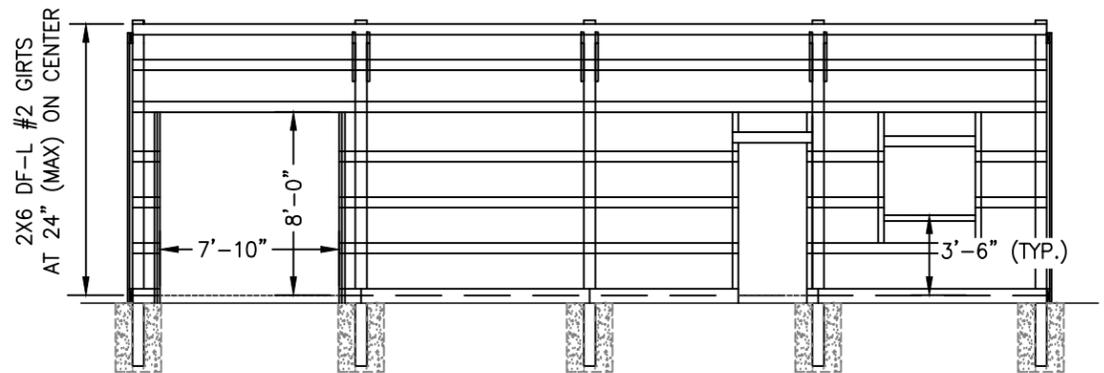

SIDE GIRT WALL - SOUTHWEST

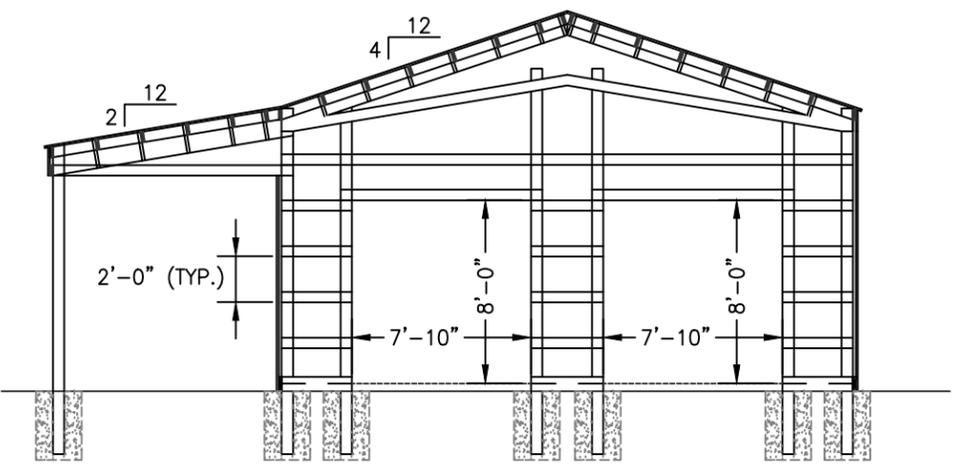

GABLE END GIRT WALL - SOUTHEAST

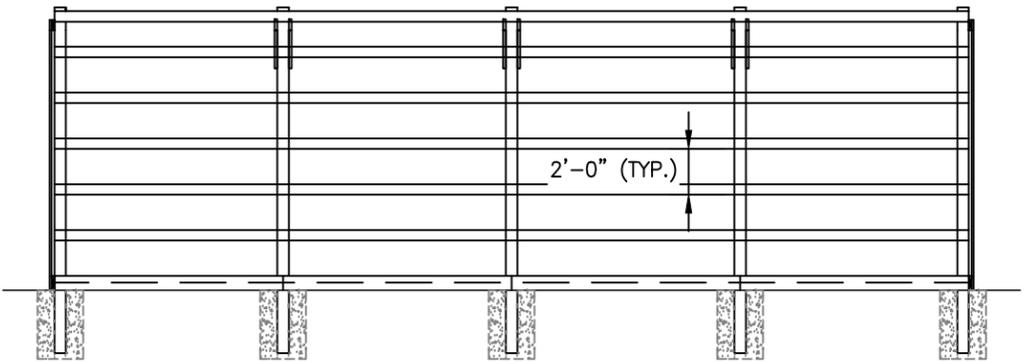

SIDE GIRT WALL - NORTHEAST

ENGINEER STAMP



ELEVATIONS

MIKE ROUNDY BUILDING
EDEN, UTAH

PROJECT
B104

SCALE
1/8" = 1'-0"

DATE
01/21/2020

SHEET
05

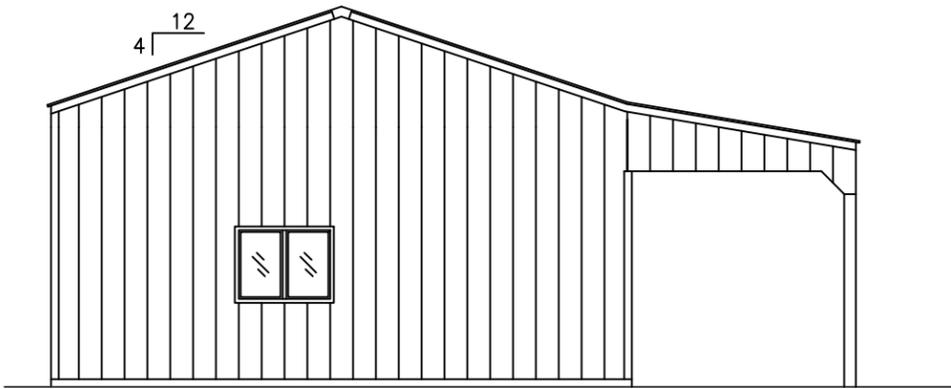

GABLE END ELEVATION - NORTHWEST

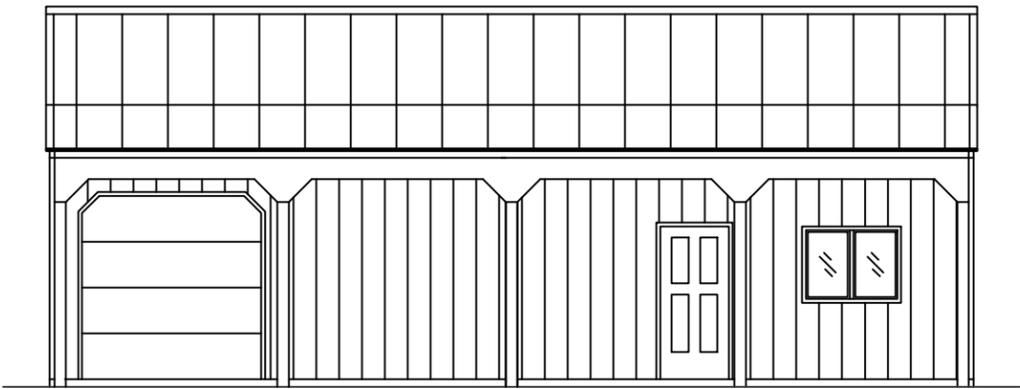

SIDE ELEVATION - SOUTHWEST

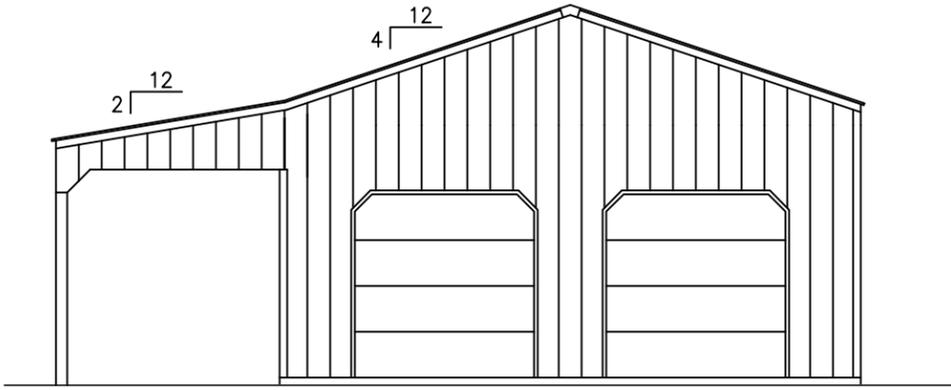

GABLE END ELEVATION - SOUTHEAST

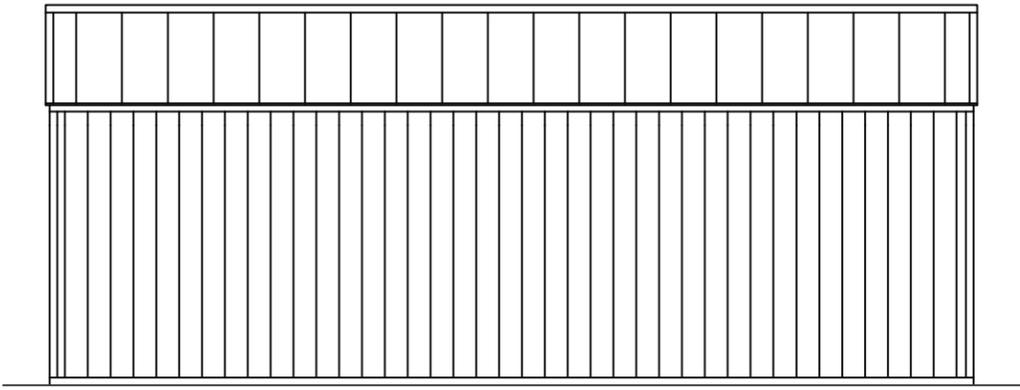

SIDE ELEVATION - NORTHEAST

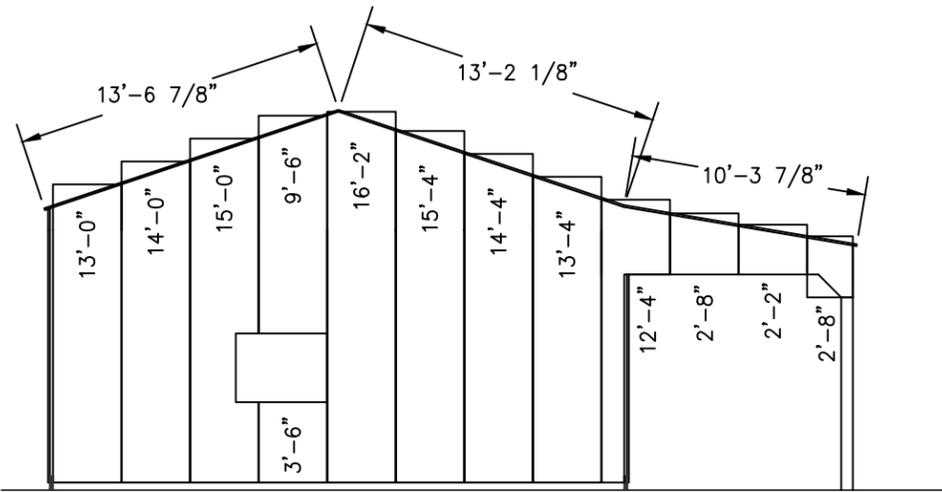

END PANEL LAYOUT - NORTHWEST

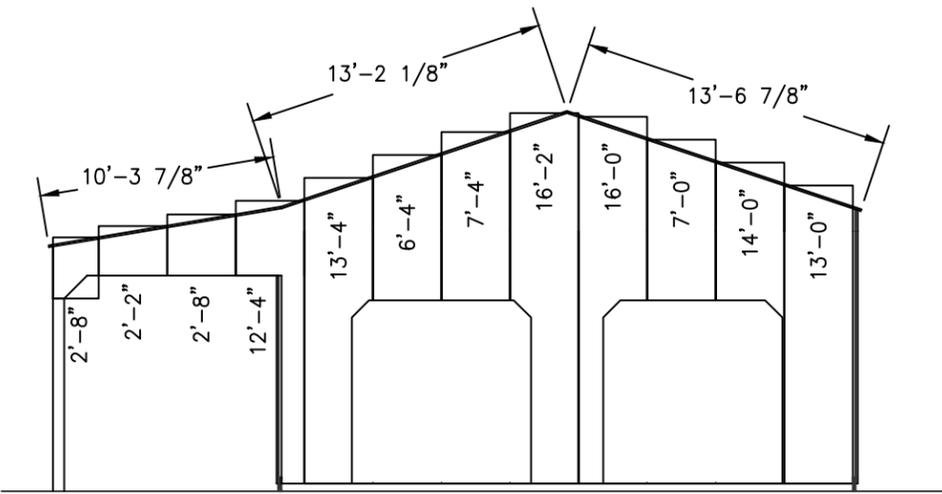

END PANEL LAYOUT - SOUTHEAST

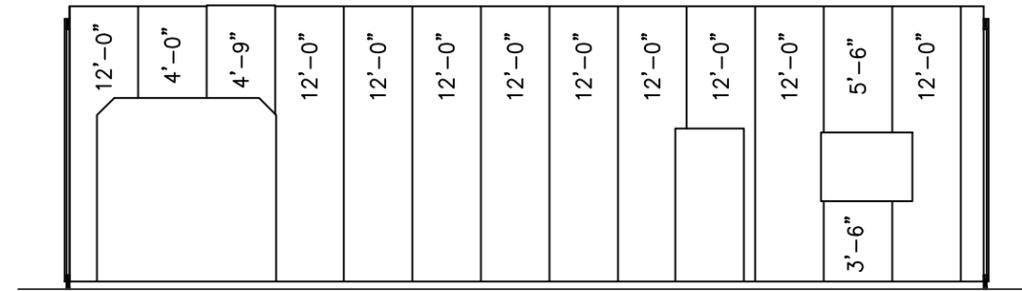

SIDE PANEL LAYOUT - SOUTHWEST

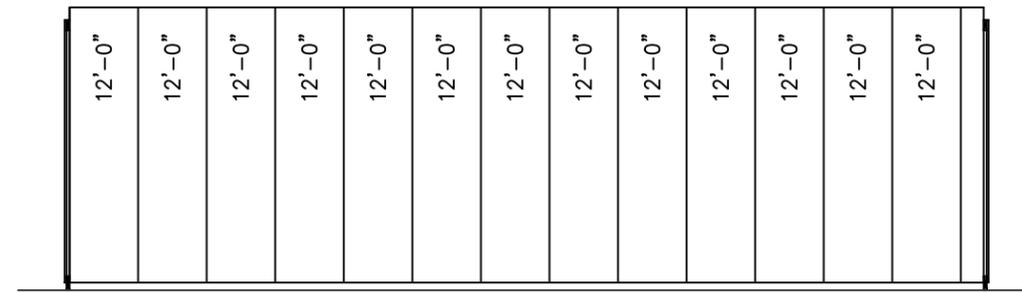

SIDE PANEL LAYOUT - NORTHEAST

ENGINEER STAMP



PANEL LAYOUT

MIKE ROUNDY BUILDING
EDEN, UTAH

PROJECT
B104

SCALE
1/8" = 1'-0"

DATE
01/21/2020

SHEET
06

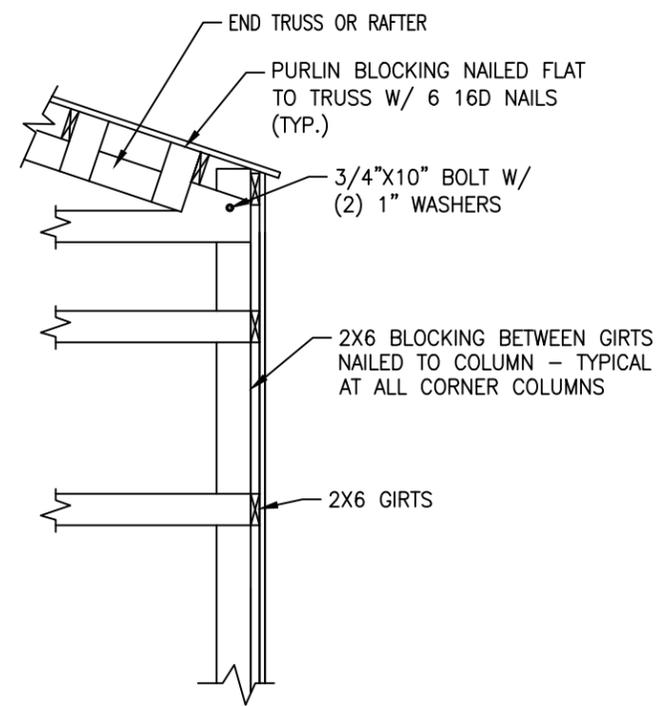
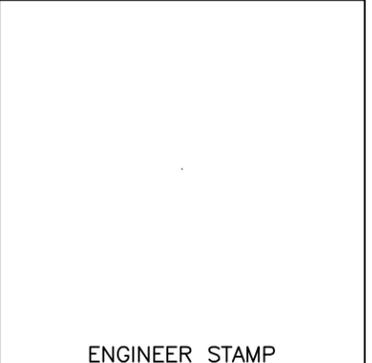

CORNER BLOCKING
NOT TO SCALE

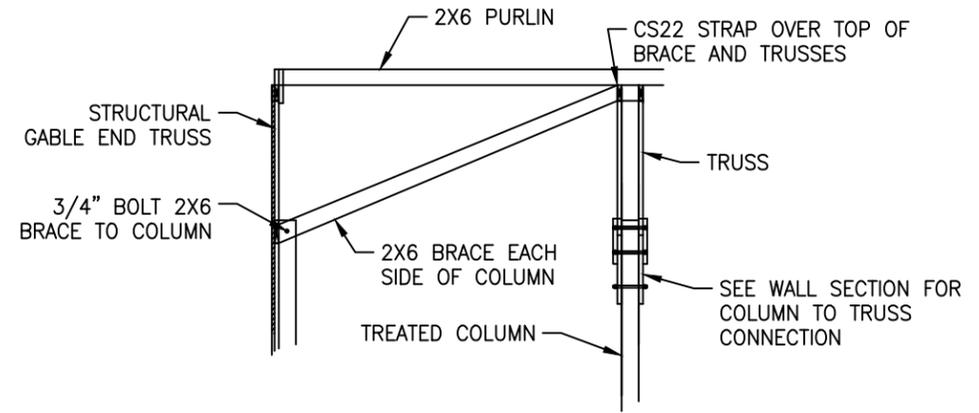

COLUMN TO TRUSS BRACE
NOT TO SCALE

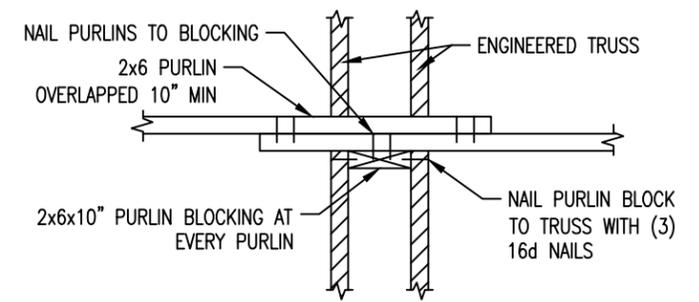

PURLIN CONNECTION
NOT TO SCALE

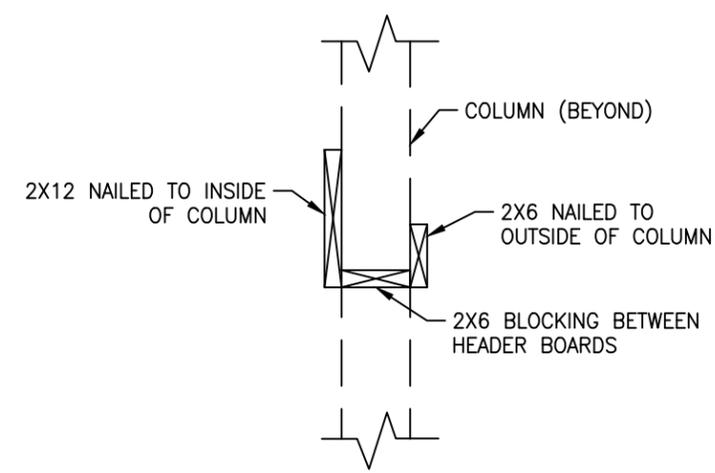

OVERHEAD DOOR HEADER
NOT TO SCALE

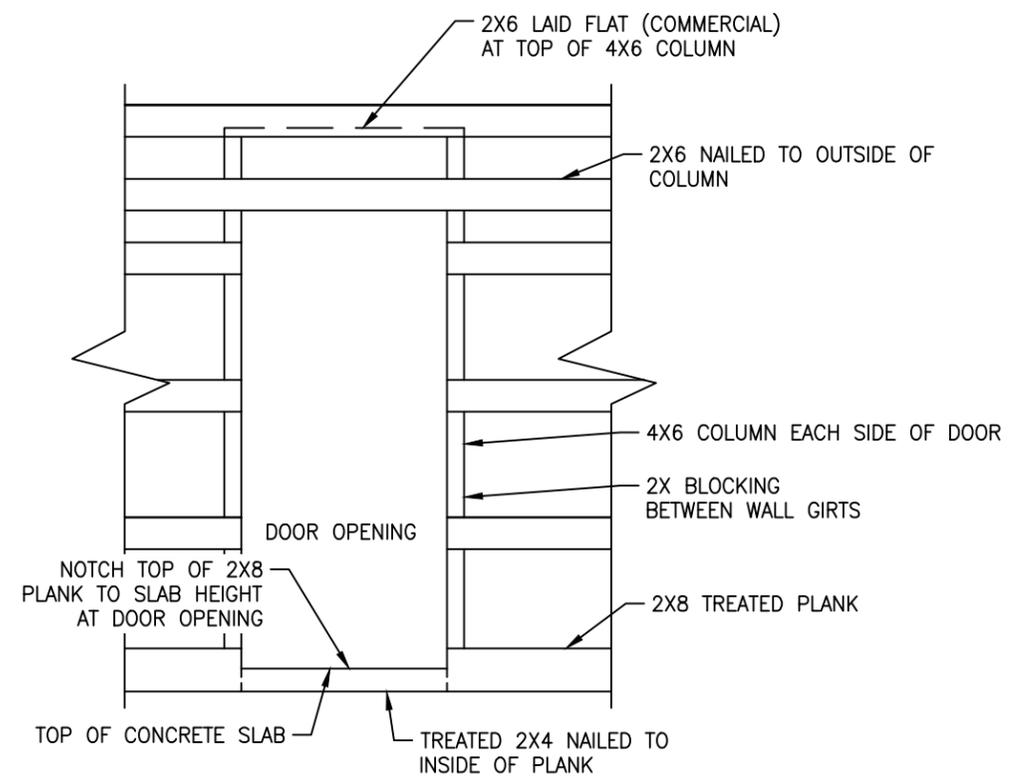

MAN DOOR OPENING
NOT TO SCALE

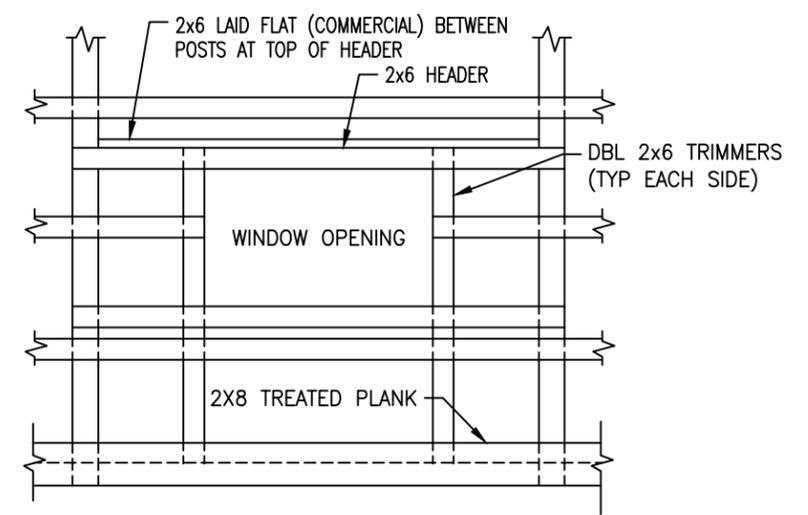

WINDOW OPENING
NOT TO SCALE

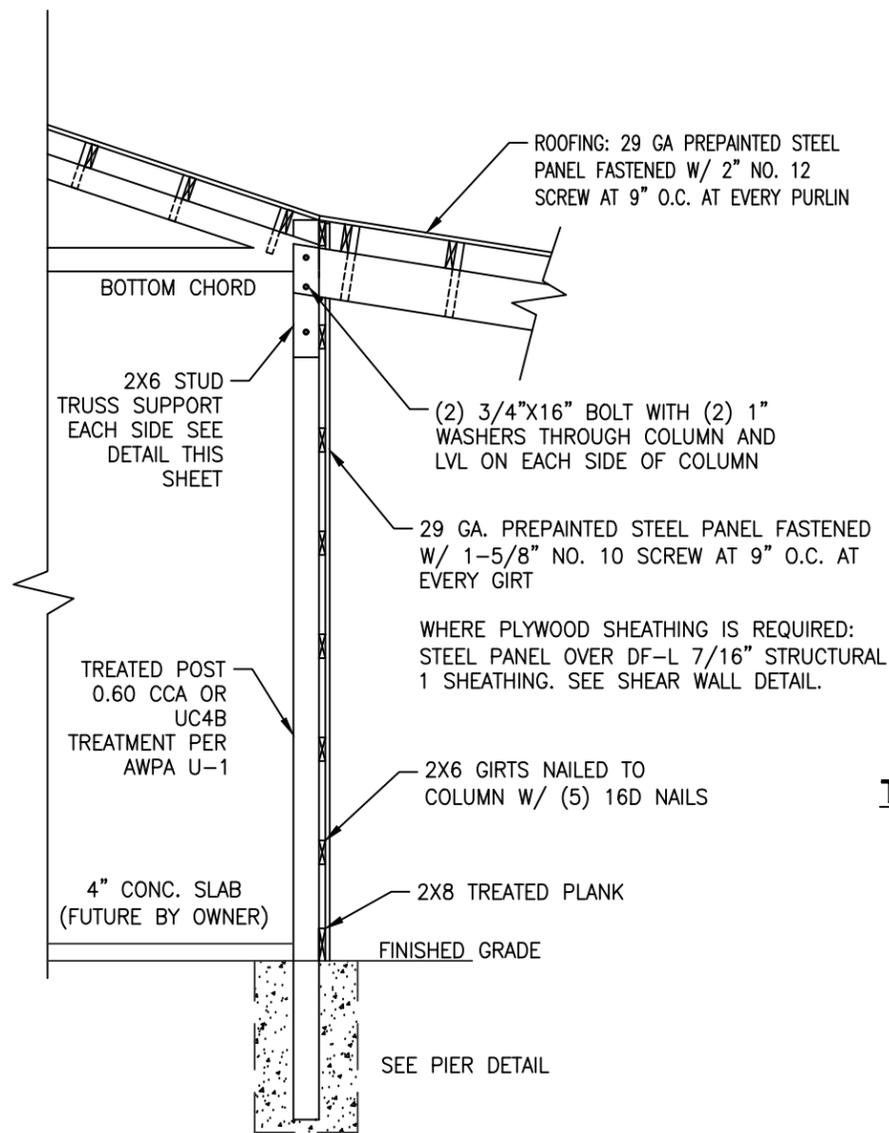

TYPICAL WALL SECTION

NOT TO SCALE

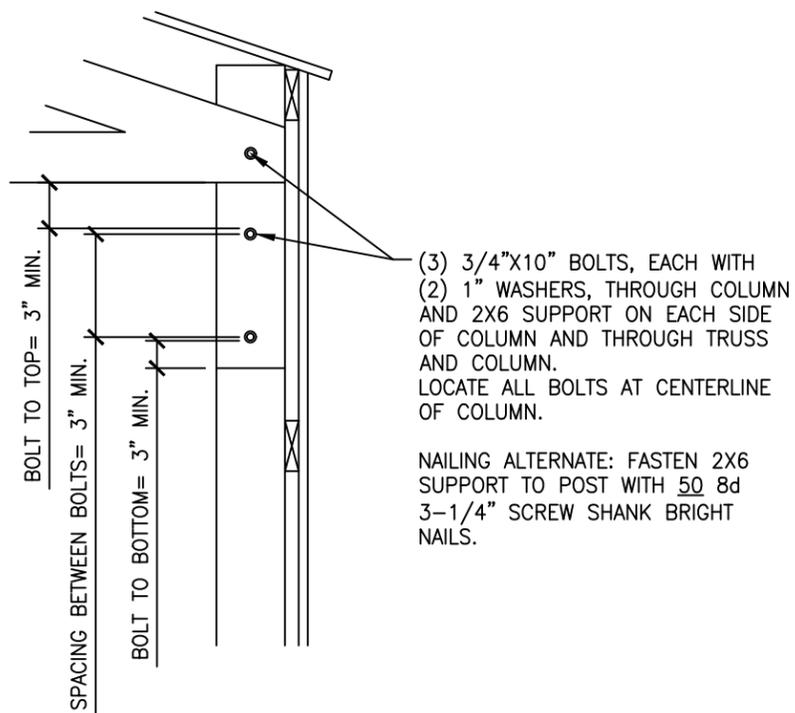

TRUSS SUPPORT TO POST CONNECTION DETAIL

NOT TO SCALE

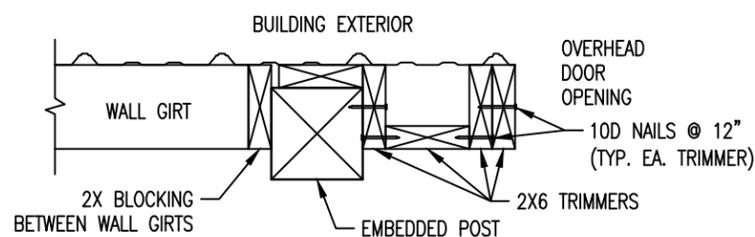

TRIMMER DETAIL

1"=1'

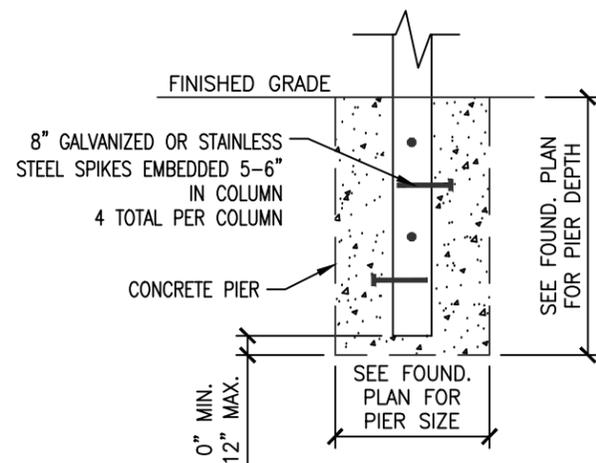

PIER DETAIL

NOT TO SCALE

ENGINEER STAMP



DETAIL SHEET

MIKE ROUNDY BUILDING
EDEN, UTAH

PROJECT
B104

SCALE
AS NOTED

DATE
01/21/2020

SHEET
08

ENGINEER STAMP

DETAIL SHEET

MIKE ROUNDY BUILDING
EDEN, UTAH

PROJECT
B104
SCALE
AS NOTED
DATE
01/21/2020
SHEET
09

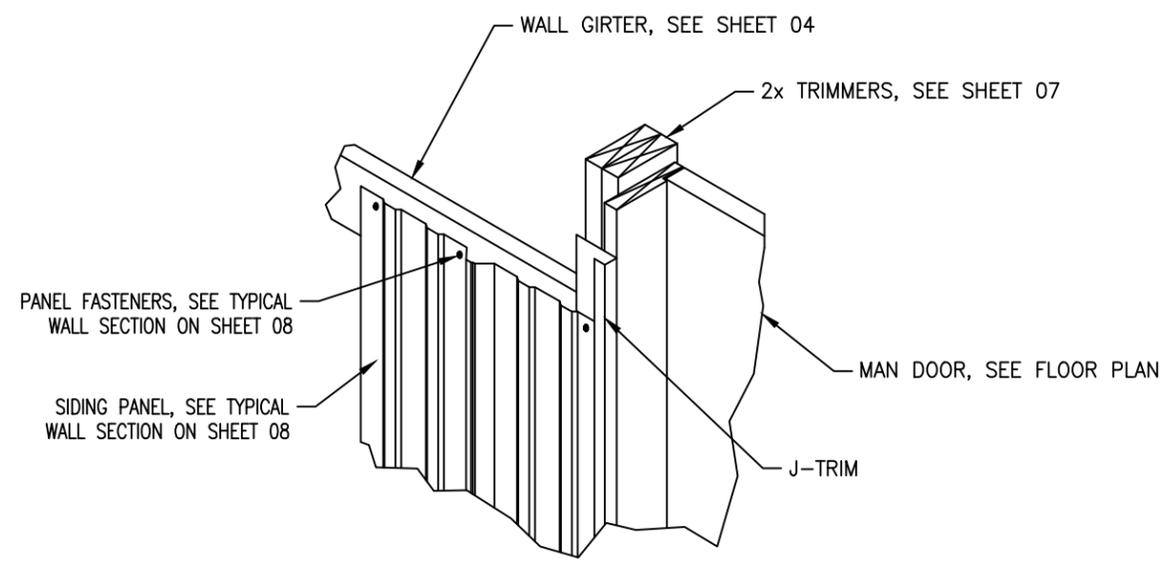

DOOR JAMB FLASHING
NOT TO SCALE

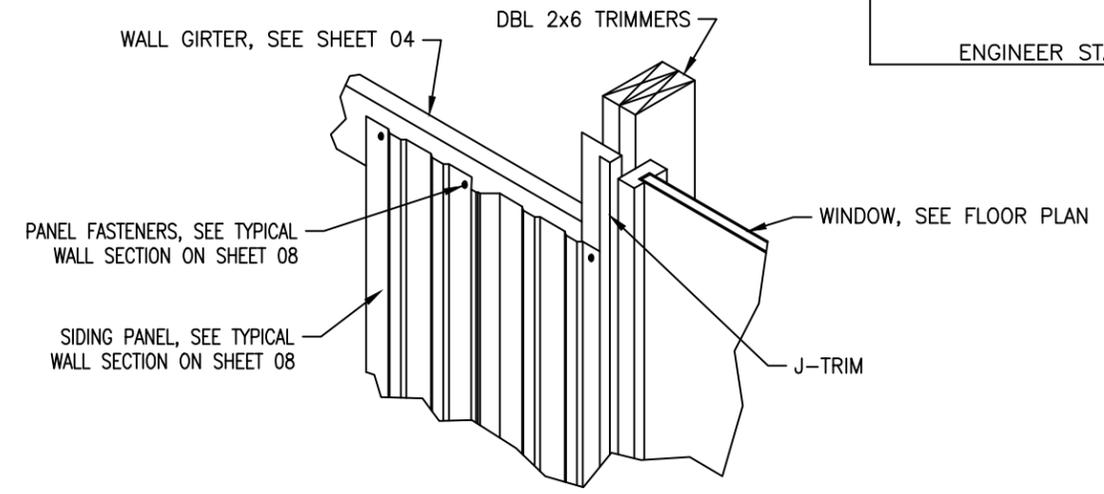

WINDOW JAMB FLASHING
NOT TO SCALE

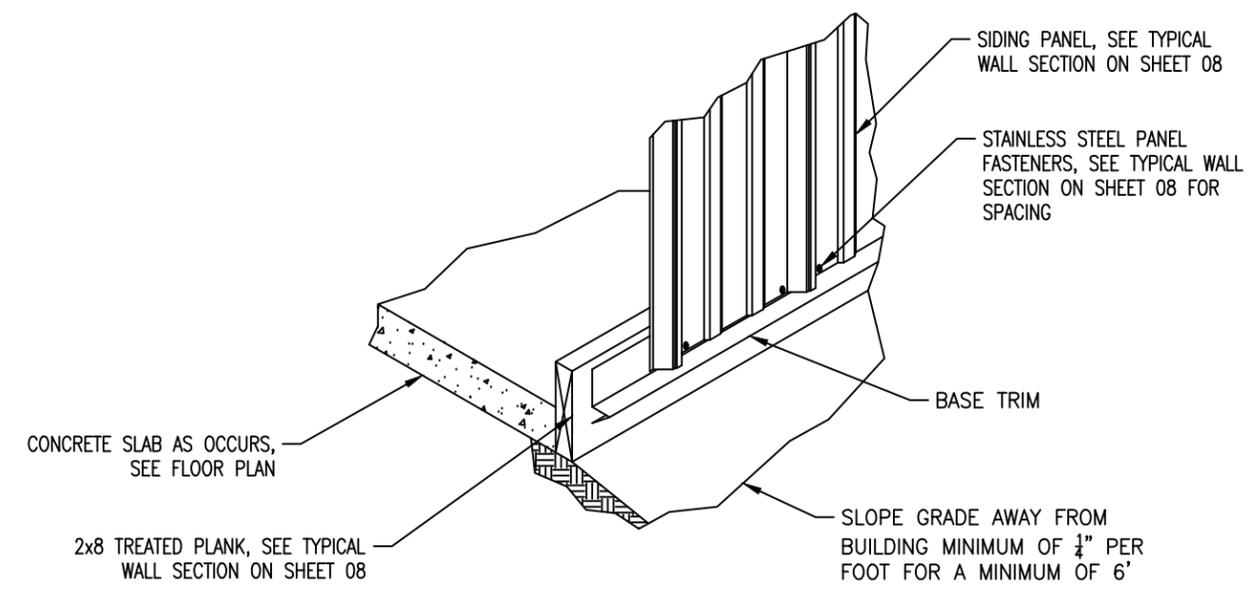

BASE GUARD FLASHING
NOT TO SCALE

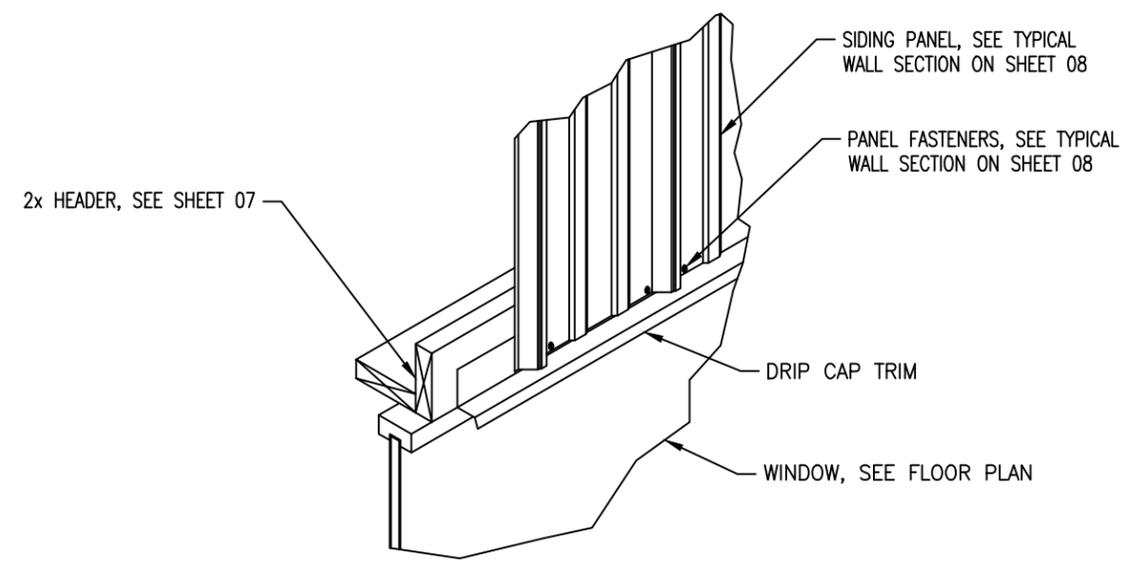

WINDOW / DOOR HEADER FLASHING
NOT TO SCALE