

**Project Narrative/Notes/Revisions**

- 1) 3/18/13 CA - DESIGN CHANGES.
- 2) 6/24/13 CA - COUNTY ENGINEERS/ROAD WAY CHANGES.
- 3) 7/3/13 RH - COUNTY ENGINEERS/ROAD WAY CHANGES.
- 4) 8/16/13 RH - COUNTY ENGINEERS COMMENTS.
- 5) 9/19/13 RH - COUNTY ENGINEERS COMMENTS.
- 6) 10/21/13 RH - SEWER SYSTEM REVISIONS.

# EDGEWATER ESTATES

## Phase-1 Improvement Plans

WEBER COUNTY, UTAH  
AUGUST 2013

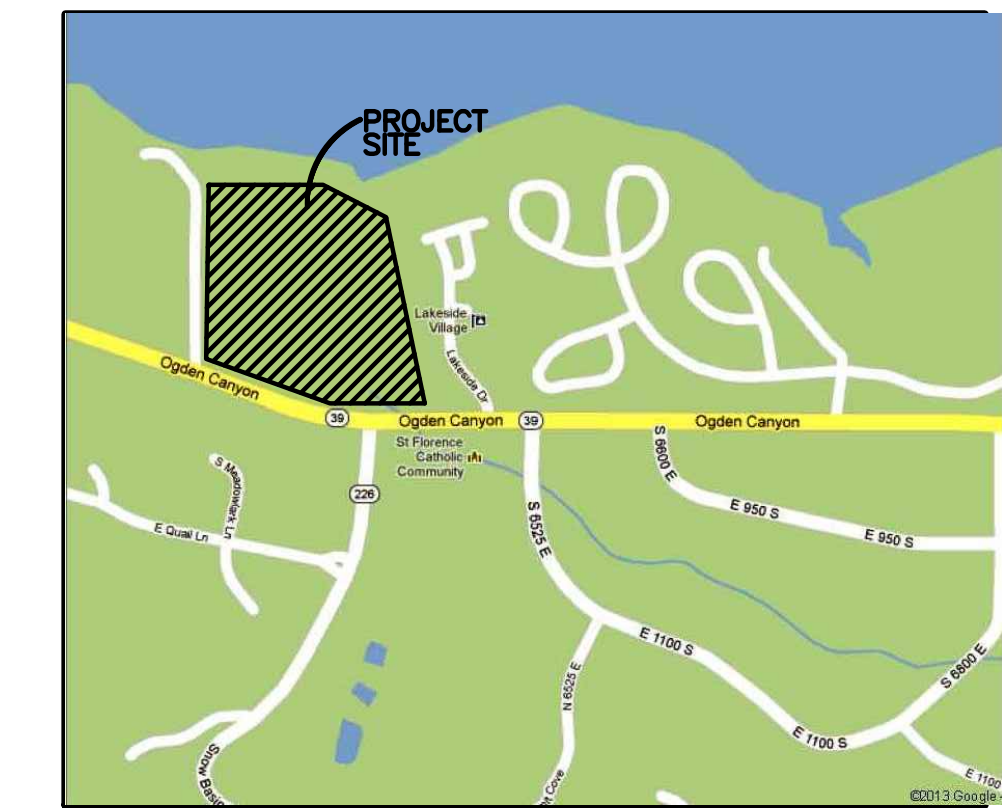

**Vicinity Map**  
NOT TO SCALE

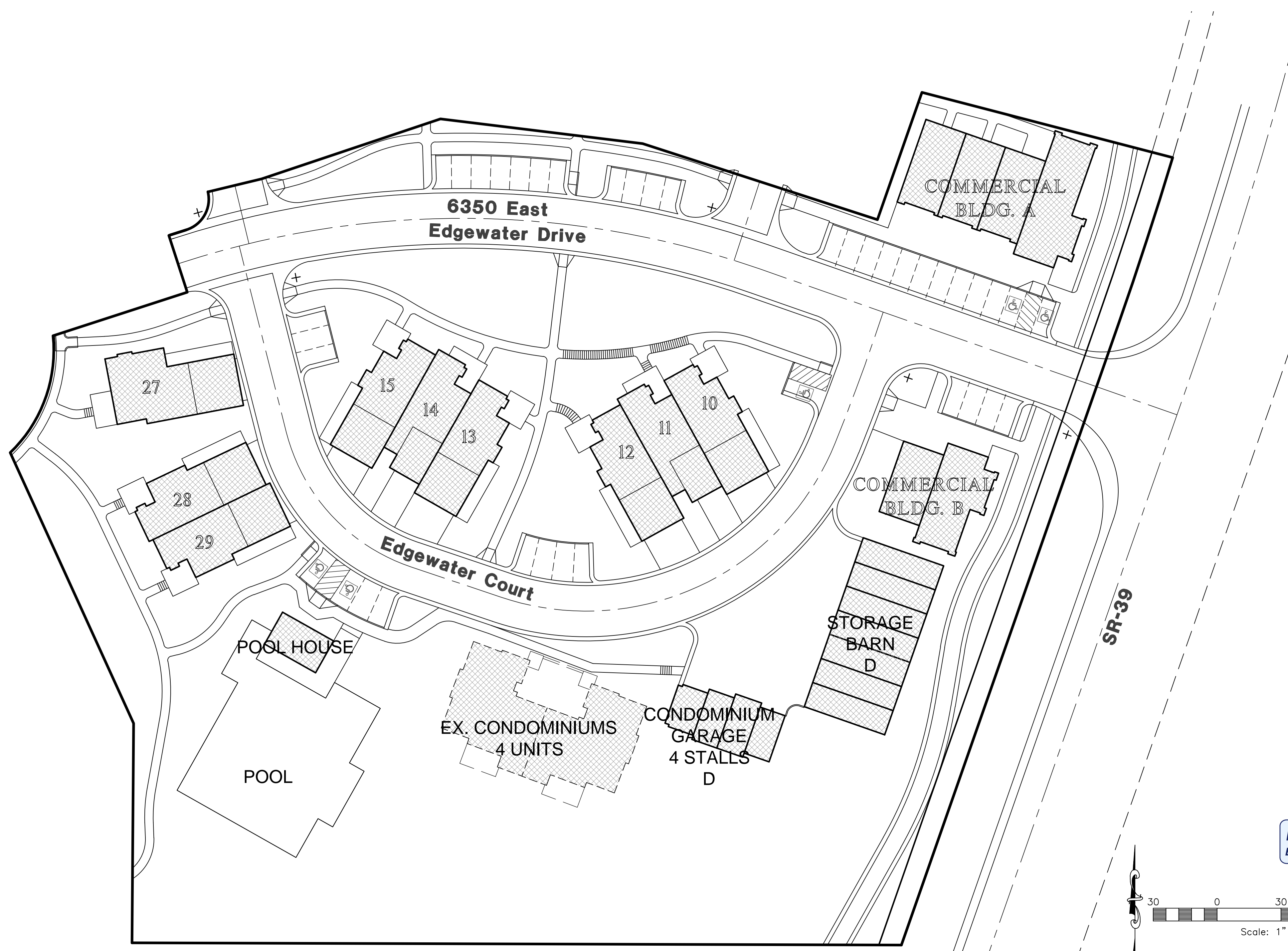

**Sheet Index**

- Sheet 1 - Cover/Index Sheet
- Sheet 2 - Demolition Plan
- Sheet 3 - Edgewater Drive 20+00.00 - 24+49.74
- Sheet 4 - Edgewater Drive 24+49.74 - 29+50.00
- Sheet 5 - Edgewater Court 15+00.00 - 21+00.00
- Sheet 6 - Drainage & Grading Plan
- Sheet 7 - Utility Plan
- Sheet 8 - SD Calculations
- Sheet 9 - Details
- Sheet 10 - Rock Wall Details
- Sheet 11 - SWPPP
- Sheet 12 - SWPPP Details

**General Notes**

1. CONSTRUCTION STAKING TO BE PROVIDED BY REEVE & ASSOCIATES, INC.
2. ANY MODIFICATION TO THIS CONSTRUCTION PACKAGE OR TO THE CONSTRUCTION SCHEDULE SHALL BE APPROVED BY THE ENGINEER PRIOR TO SAID APPROVAL, ALL IMPROVEMENT DRAWINGS SHALL BE RESUBMITTED AND APPROVED BY THE ARCHITECT.
3. THE CONTRACTOR SHALL LOCATE, RETAIN AND PROTECT ALL EXISTING UTILITIES UNLESS OTHERWISE DIRECTED BY THE OWNER OR OWNER'S REPRESENTATIVE.
4. THE CONTRACTOR SHALL MAINTAIN 10 FOOT HORIZONTAL AND 18 INCH VERTICAL SEPARATION, CULINARY WATER LINES, SANITARY SEWER, AND STORM DRAIN LINES.
5. THE CONTRACTOR SHALL INSTALL ALL SANITARY SEWER MAINS, SERVICE LINES AND STORM DRAIN LINES PRIOR TO INSTALLING ANY WATER SYSTEM IMPROVEMENTS. ADJUST WATER MAIN DEPTH PER JURISDICTION AS REQUIRED TO AVOID SANITARY SEWER SERVICE LINES.
6. CONTRACTOR SHALL NOTIFY ARCHITECT OF ALL UTILITY CONFLICTS UPON DISCOVERY.
7. CONTRACTOR SHALL COORDINATE CONSTRUCTION AND INSTALLATION OF ELECTRICAL, TELEPHONE, NATURAL GAS AND CABLE TV SERVICES WITH THE RESPECTIVE UTILITY COMPANY. OWNER SHALL PAY ALL ASSOCIATED UTILITY COMPANY FEES.
8. CONTRACTOR SHALL BE RESPONSIBLE FOR PROPER SLOPE AND CONSTRUCTION OF CONNECTING SEWER PIPING.
9. CONTRACTOR SHALL BE RESPONSIBLE OF PROPER BACKFILLING, COMPACTING, AND PAVEMENT RESTORATION.
10. CONTRACTOR TO OBTAIN ALL NECESSARY PERMIT(S) AND COMPLY WITH ALL PERMITTING REQUIREMENTS.
11. ALL THRUST BLOCKS SHALL BE POURED IN PLACE AGAINST UNDISTURBED SOIL. ALL VALVES, FITTINGS, AND APPURTENANCES TO BE BLOCKED.
12. ALL EXPOSED NUTS AND BOLTS WILL BE COATED WITH A NON-OXIDE WASH AND WRAPPED IN 8-MIL POLYETHYLENE AS DIRECTED BY GEOTECHNICAL STUDY.
13. CONTRACTOR SHALL BE RESPONSIBLE FOR DUST CONTROL ACCORDING TO GOVERNING AGENCIES STANDARDS. WET DOWN DRY MATERIALS AND RUBBISH TO PREVENT BLOWING.
14. CONTRACTOR SHALL BE RESPONSIBLE FOR ANY DAMAGE TO ADJACENT SURFACE IMPROVEMENTS DURING CONSTRUCTION.
15. CONTRACTOR SHALL BE RESPONSIBLE FOR CORRECTING ANY SETTLEMENT OF OR DAMAGE TO EXISTING UTILITIES FOR WARRANTY PERIOD.
16. ALL EXISTING ASPHALT SHALL BE SAW CUT IN NEAT STRAIGHT LINES BY THE CONTRACTOR PRIOR TO EXCAVATION.
17. CONTRACTOR TO INSTALL MAGNETIC LOCATING TAPE CONTINUOUSLY OVER ALL PVC PIPING.
18. THE CONTRACTOR IS RESPONSIBLE TO FURNISH ALL MATERIALS TO COMPLETE PROJECT.
19. TRAFFIC CONTROL IS TO CONFORM TO THE CURRENT CITY AND/OR STATE TRANSPORTATION ENGINEERS' MANUAL.
20. A UPDES GENERAL CONSTRUCTION STORM WATER PERMIT MUST BE OBTAINED BY THE GENERAL CONTRACTOR PRIOR TO COMMENCING CONSTRUCTION.
21. ALL WORK SHALL CONFORM TO WEBER COUNTY STANDARD SPECIFICATIONS AND DRAWINGS.

**RECEIVED**  
By Michael Tuttle at 8:32 am, Oct 23, 2013

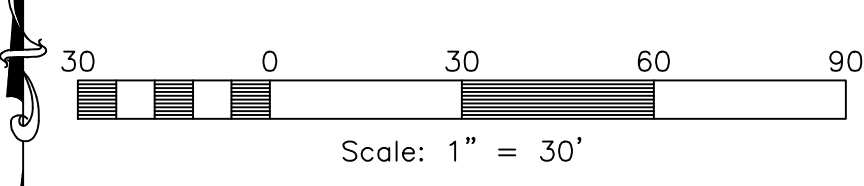

**Elevation Datum**  
SITE BENCHMARK:  
BENCH MARK MONUMENT NO. 3-JRH  
ELEVATION 4969.025

**Engineer's Notice To Contractors**  
THE EXISTENCE AND LOCATION OF ANY UNDERGROUND UTILITY PIPES OR STRUCTURES SHOWN ON THESE PLANS WERE OBTAINED FROM AVAILABLE INFORMATION PROVIDED BY OTHERS. THE LOCATIONS SHOWN ARE APPROXIMATE AND SHALL BE CONFIRMED IN THE FIELD BY THE CONTRACTOR, SO THAT ANY NECESSARY ADJUSTMENT CAN BE MADE IN ALIGNMENT AND/OR GRADE OF THE PROPOSED IMPROVEMENT. THE CONTRACTOR IS REQUIRED TO CONTACT THE UTILITY COMPANIES AND TAKE DUE PRECAUTIONARY MEASURE TO PROTECT ANY UTILITY LINES SHOWN, AND ANY OTHER LINES OBTAINED BY THE CONTRACTOR'S RESEARCH, AND OTHERS NOT OF RECORD OR NOT SHOWN ON THESE PLANS.

**Contact:**  
REESE HOWELL, JR.  
CELTIC BANK 268 S. STATE  
STREET, UT. 84111  
PH: (801) 363-6500

Blue Stakes Location Center  
**Call: Toll Free**  
**1-800-662-4111**  
Two Working Days Before You Dig

**Reeve & Associates, Inc.**  
920 CHAMBERS STREET, SUITE 14, OGDEN, UTAH 84403  
TEL: (801) 621-2100 FAX: (801) 621-2666 www.reeve-assoc.com  
LAND PLANNERS • CIVIL ENGINEERS • LAND SURVEYORS  
TRA ARCHITECTS  
TRA ARCHITECTS

REVISIONS	DATE	DESCRIPTION
7-31-12	RH	Design Complete
3-14-13	CA	Design Complete
6-21-13	RH	Co. Eng. Review
7-3-13	RH	Co. Eng. Review
8-16-13	RH	Co. Eng. Review
9-19-13	RH	Co. Eng. Review
10-21-13	RH	Sewer Revisions

**Edgewater Beach Resort**  
**Phase-1**  
WEBER COUNTY, UTAH  
**Cover/Index Sheet**

Revised 10-21-13



**Project Info.**  
Engineer:  
J. NATE REEVE, P.E.  
Drafted:  
R. HANSEN  
Begin Date:  
JULY 09, 2012  
Name:  
EDGEWATER BEACH  
RESORT  
PHASE-1  
Number: 5917-15

Sheet **12**  
**1** Sheets



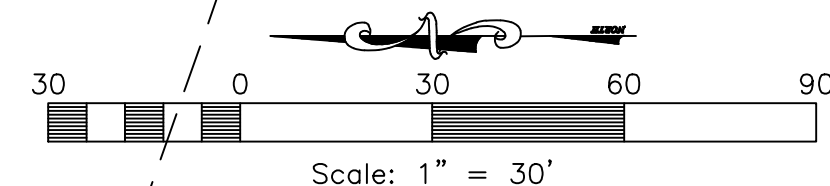
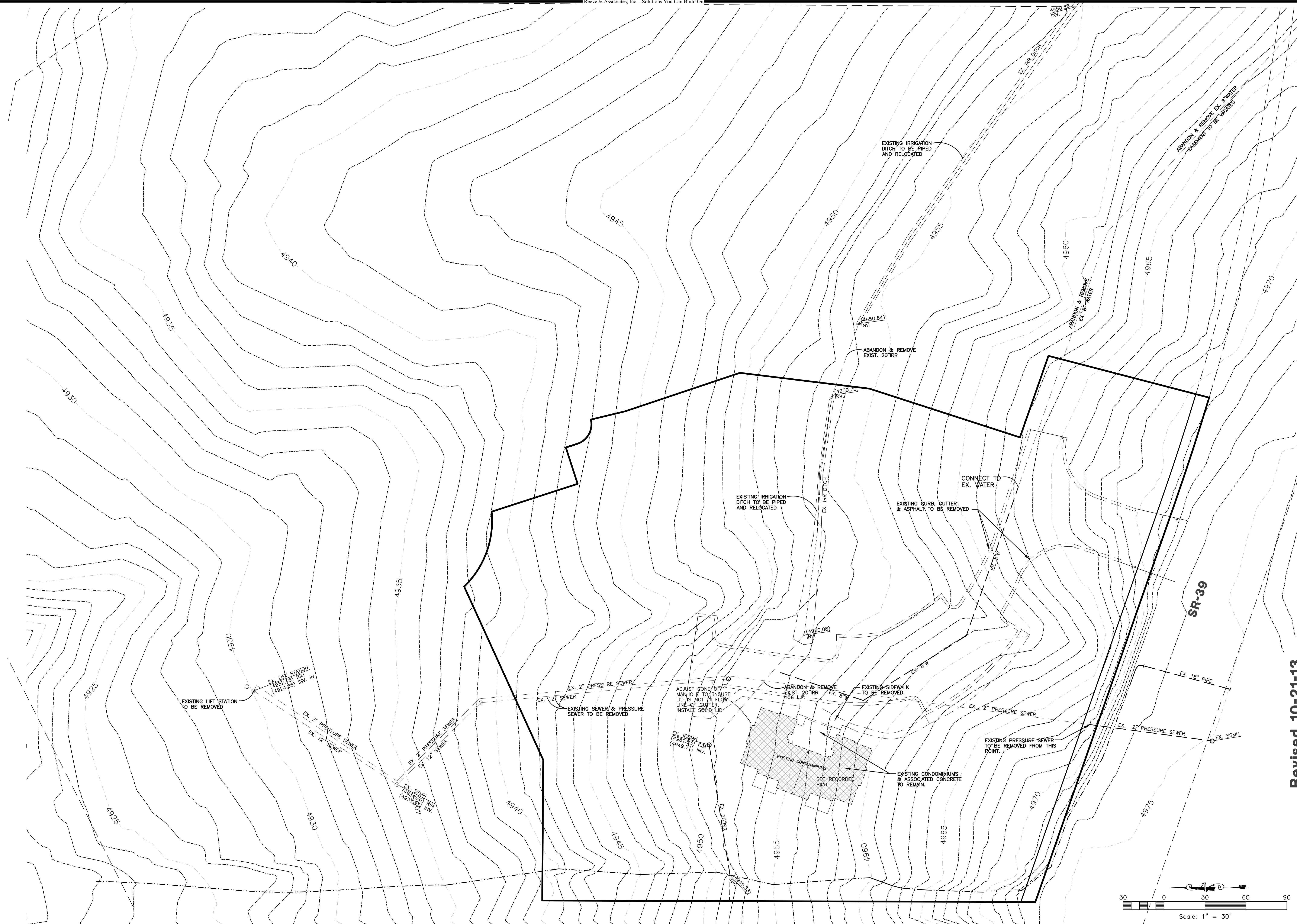

**Reeve & Associates, Inc.**  
**IRA**  
 920 CHAMBERS STREET, SUITE #14, OGDEN, UTAH 84403  
 TEL: (801) 921-2100 FAX: (801) 621-2666 www.reeve-assoc.com  
 LAND PLANNERS • CIVIL ENGINEERS • LAND SURVEYORS  
 PUBLIC ENGINEERS • STRUCTURAL ENGINEERS • LANDSCAPE ARCHITECTS

DATE	DESCRIPTION
7-31-12	RH Design Complete
3-14-13	CA Design Complete
6-21-13	RH Co. Eng. Review
7-3-13	RH Co. Eng. Review
8-16-13	RH Co. Eng. Review
9-19-13	RH Co. Eng. Review
10-21-13	RH Sewer Revisions

**Edgewater Beach Resort  
 Phase-1**  
 WEBER COUNTY, UTAH  
**Demolition Plan**

**Revised 10-21-13**

**Project Info.**

Engineer:	J. NATE REEVE, P.E.
Drafter:	R. HANSEN
Begin Date:	JULY 09, 2012
Name:	EDGEWATER BEACH RESORT PHASE-1
Number:	5917-15



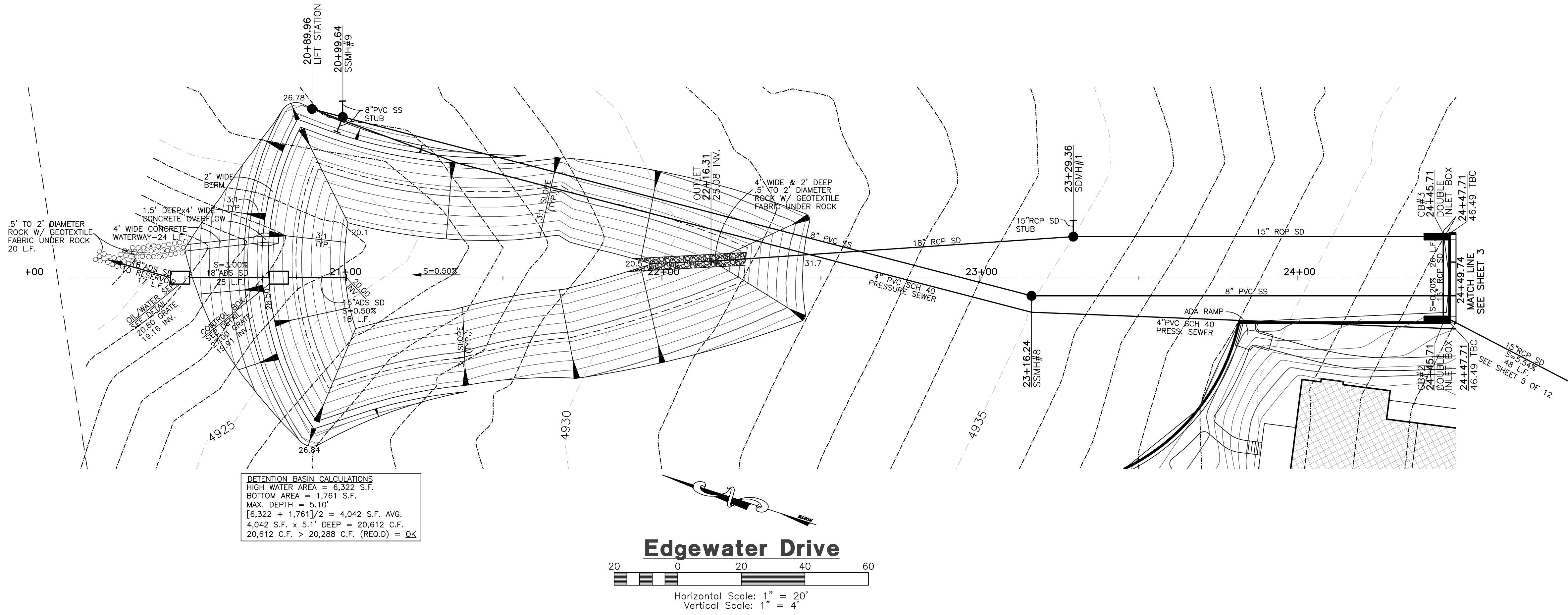

**DETENTION BASIN CALCULATIONS**  
 HIGH WATER AREA = 6,322 S.F.  
 BOTTOM AREA = 1,761 S.F.  
 MAX. DEPTH = 5.10'  
 $(6,322 + 1,761) / 2 = 4,042$  S.F. AVG.  
 $4,042$  S.F. x 5.1' DEEP = 20,612 C.F.  
 $20,612$  C.F. > 20,288 C.F. (REQ'D) = OK

**Edgewater Drive**

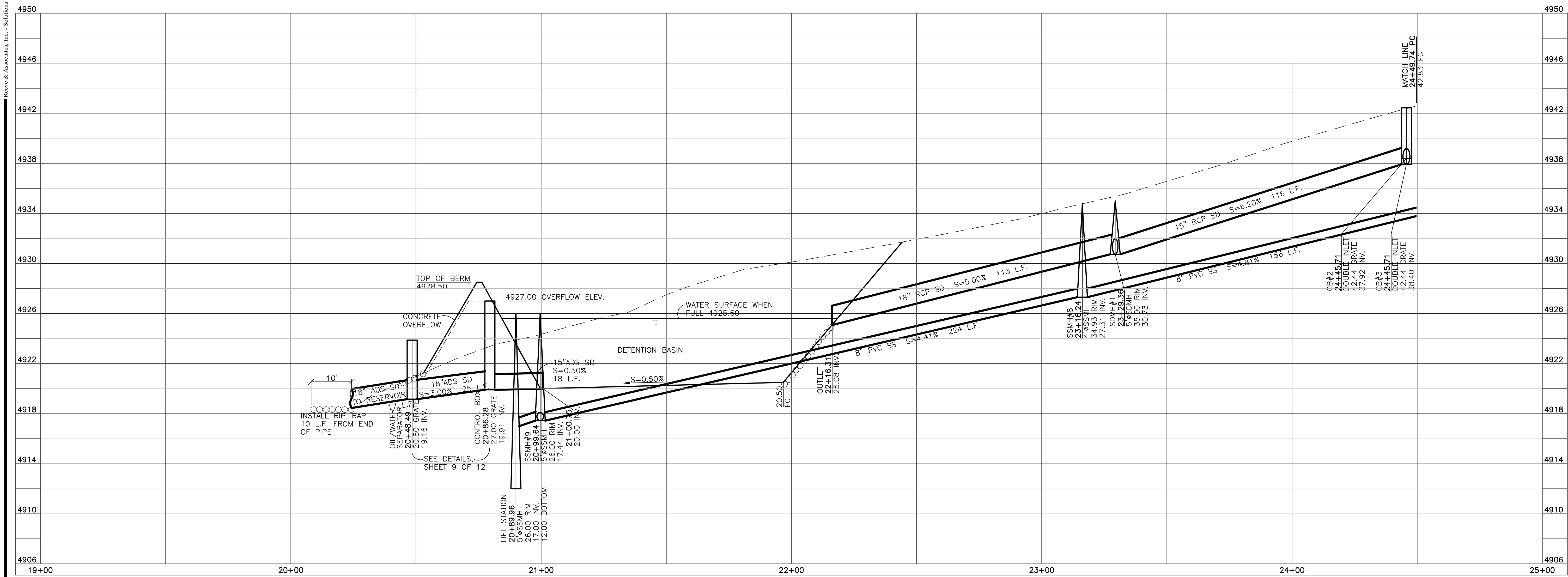
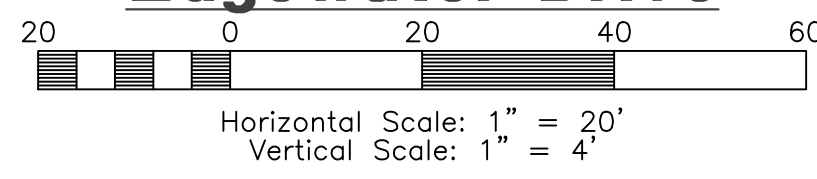

**Reeve & Associates, Inc.**  
**IRA**  
 920 CHAMBERS STREET, SUITE #14, OGDEN, UTAH 84403  
 TEL: (801) 621-2100 FAX: (801) 621-2666 WWW.REEVE-ASSOC.COM  
 LAND PLANNERS • CIVIL ENGINEERS • LAND SURVEYORS  
 PUBLIC ENGINEERS • STRUCTURAL ENGINEERS • LANDSCAPE ARCHITECTS

DATE	REVISIONS	DESCRIPTION
7-31-12	RH	Design Complete
3-14-13	CA	Design Complete
6-21-13	RH	Co. Eng. Review
7-3-13	RH	Co. Eng. Review
8-16-13	RH	Co. Eng. Review
9-19-13	RH	Co. Eng. Review
10-21-13	RH	Sewer Revisions

**Edgewater Beach Resort**  
**Phase-1**  
 WEBER COUNTY, UTAH  
**Edgewater Drive**  
**20+00.00 - 24+49.74**

Revised 10-21-13

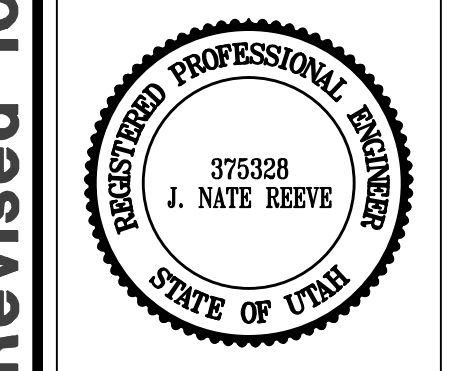

**Project Info.**

Engineer:	J. NATE REEVE, P.E.
Drafter:	R. HANSEN
Begin Date:	JULY 09, 2012
Name:	EDGEWATER BEACH RESORT PHASE-1
Number:	5917-15



DATE	DESCRIPTION
7-31-12	RH Design Complete
3-18-13	CA Design Complete
6-21-13	RH Co. Eng. Review
7-3-13	RH Co. Eng. Review
8-16-13	RH Co. Eng. Review
9-19-13	RH Co. Eng. Review
10-21-13	RH Sewer Revisions

**Edgewater Beach Resort Phase-1**  
 WEBER COUNTY, UTAH  
**Edgewater Drive**  
 24+49.74 - 30+00.00

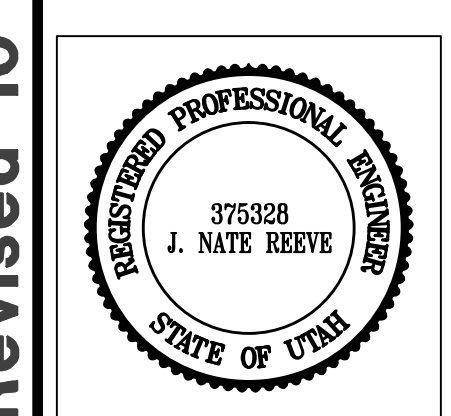

**Project Info.**  
 Engineer: J. NATE REEVE, P.E.  
 Drafter: R. HANSEN  
 Begin Date: JULY 09, 2012  
 Name: EDGEWATER BEACH RESORT  
 PHASE-1  
 Number: 5917-15

Reeve & Associates, Inc. - Solutions You Can Build On

Revised 10-21-13

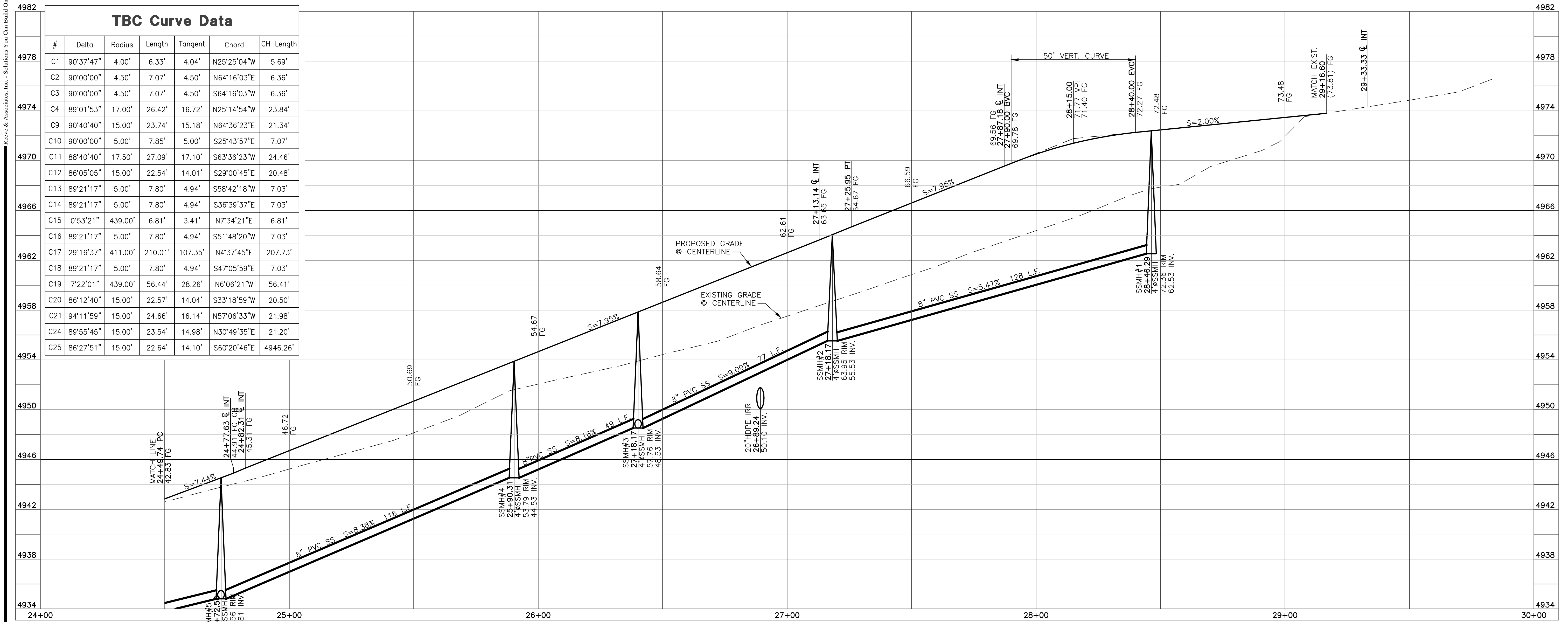

**TBC Curve Data**

#	Delta	Radius	Length	Tangent	Chord	CH Length
C1	90°37'47"	4.00'	6.33'	4.04'	N25°25'04"W	5.69'
C2	90°00'00"	4.50'	7.07'	4.50'	N64°16'03"E	6.36'
C3	90°00'00"	4.50'	7.07'	4.50'	S64°16'03"W	6.36'
C4	89°01'53"	17.00'	26.42'	16.72'	N25°14'54"W	23.84'
C9	90°40'40"	15.00'	23.74'	15.18'	N64°36'23"E	21.34'
C10	90°00'00"	5.00'	7.85'	5.00'	S25°43'57"E	7.07'
C11	88°40'40"	17.50'	27.09'	17.10'	S63°36'23"W	24.46'
C12	86°05'05"	15.00'	22.54'	14.01'	S29°00'45"E	20.48'
C13	89°21'17"	5.00'	7.80'	4.94'	S58°42'18"W	7.03'
C14	89°21'17"	5.00'	7.80'	4.94'	S36°39'37"E	7.03'
C15	0°53'21"	439.00'	6.81'	3.41'	N7°34'21"E	6.81'
C16	89°21'17"	5.00'	7.80'	4.94'	S51°48'20"W	7.03'
C17	29°16'37"	411.00'	210.01'	107.35'	N4°37'45"E	207.73'
C18	89°21'17"	5.00'	7.80'	4.94'	S47°05'59"E	7.03'
C19	7°22'01"	439.00'	56.44'	28.26'	N6°06'21"W	56.41'
C20	86°12'40"	15.00'	22.57'	14.04'	S33°18'59"W	20.50'
C21	94°11'59"	15.00'	24.66'	16.14'	N57°06'33"W	21.98'
C24	89°55'45"	15.00'	23.54'	14.98'	N30°49'35"E	21.20'
C25	86°27'51"	15.00'	22.64'	14.10'	S60°20'46"E	4946.26'



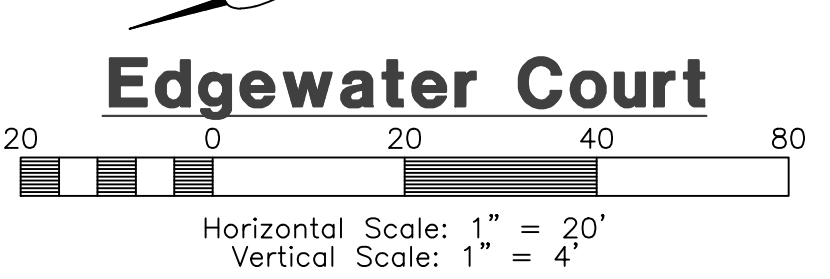
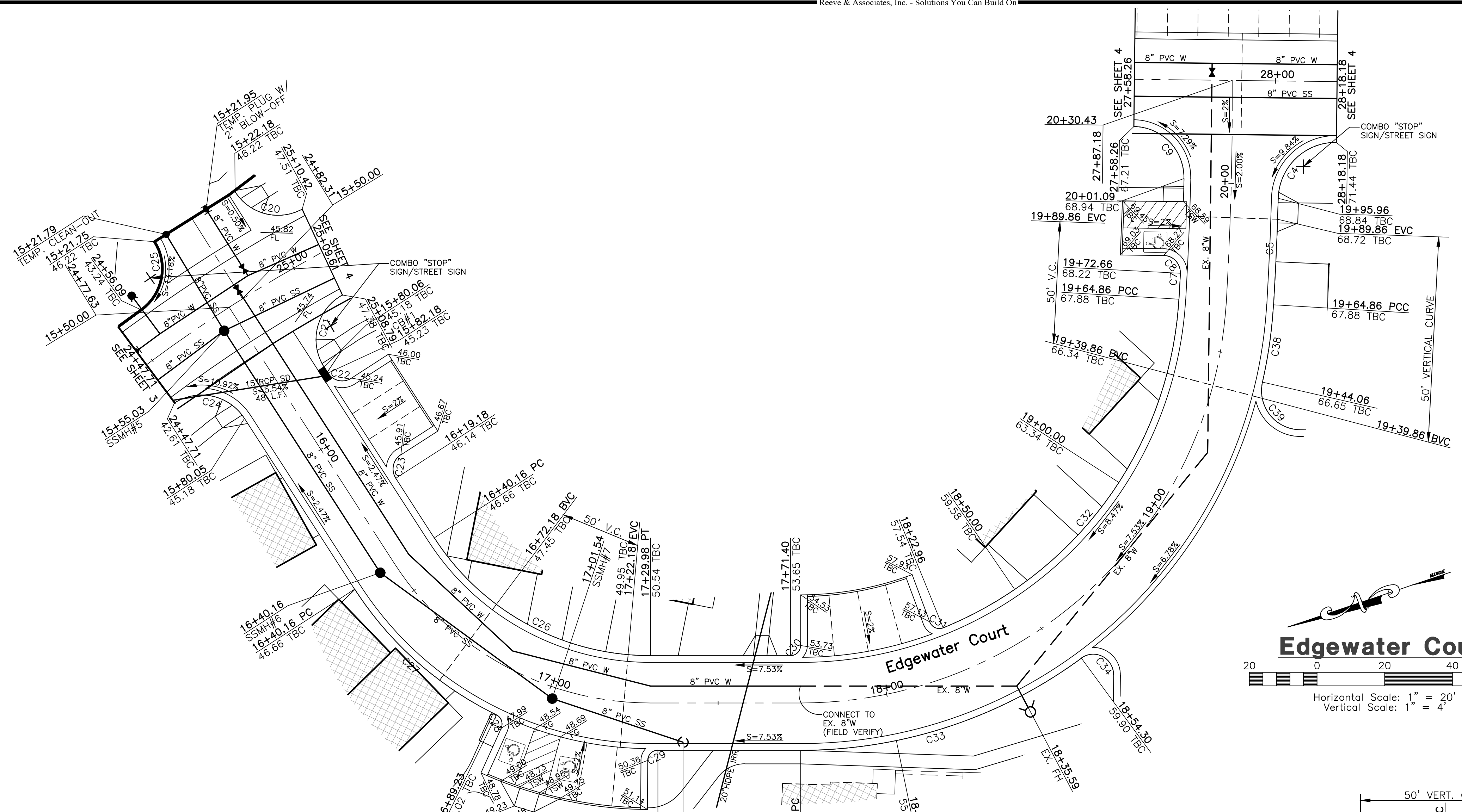

TBC Curve Data						
#	Delta	Radius	Length	Tangent	Chord	CH Length
C4	89°01'53"	17.00'	26.42'	16.72'	N25°14'54"W	23.84'
C5	1°45'41"	1025.50'	31.52'	15.76'	S68°53'00"E	31.52'
C7	0°26'31"	997.50'	7.69'	3.85'	S68°13'25"E	7.69'
C8	92°17'17"	5.00'	8.05'	5.20'	N65°24'41"E	7.21'
C9	90°40'40"	15.00'	23.74'	15.18'	N64°36'23"E	21.34'
C20	86°12'40"	15.00'	22.57'	14.04'	S33°18'59"W	20.50'
C21	94°11'59"	15.00'	24.66'	16.14'	N57°06'33"W	21.98'
C22	90°00'00"	5.00'	7.85'	5.00'	S30°47'27"W	7.07'
C23	90°00'00"	5.00'	7.85'	5.00'	N59°12'33"W	7.07'
C24	89°55'45"	15.00'	23.54'	14.98'	N30°49'35"E	21.20'
C25	86°27'51"	15.00'	22.64'	14.10'	S60°20'46"E	4946.26'
C26	57°11'04"	76.00'	75.85'	41.42'	S47°11'55"W	72.74'
C27	31°14'27"	104.00'	56.71'	29.08'	S60°10'14"W	56.01'
C28	88°23'36"	3.00'	4.63'	2.92'	N88°44'49"E	4.18'
C29	89°34'57"	3.00'	4.69'	2.98'	N26°11'05"W	4.23'
C30	90°00'00"	3.00'	4.71'	3.00'	S26°23'37"E	4.24'
C31	91°34'38"	3.00'	4.79'	3.08'	S42°18'43"W	4.30'
C32	64°31'34"	112.00'	126.13'	70.70'	S35°44'22"E	119.57'
C33	36°20'01"	140.00'	88.78'	45.94'	S0°26'23"W	87.30'
C34	126°59'59"	6.00'	13.30'	12.03'	N45°46'21"E	10.74'
C38	9°27'36"	140.00'	23.12'	11.58'	S63°16'21"E	23.09'
C39	102°11'03"	11.50'	20.51'	14.25'	S70°21'55"W	17.90'

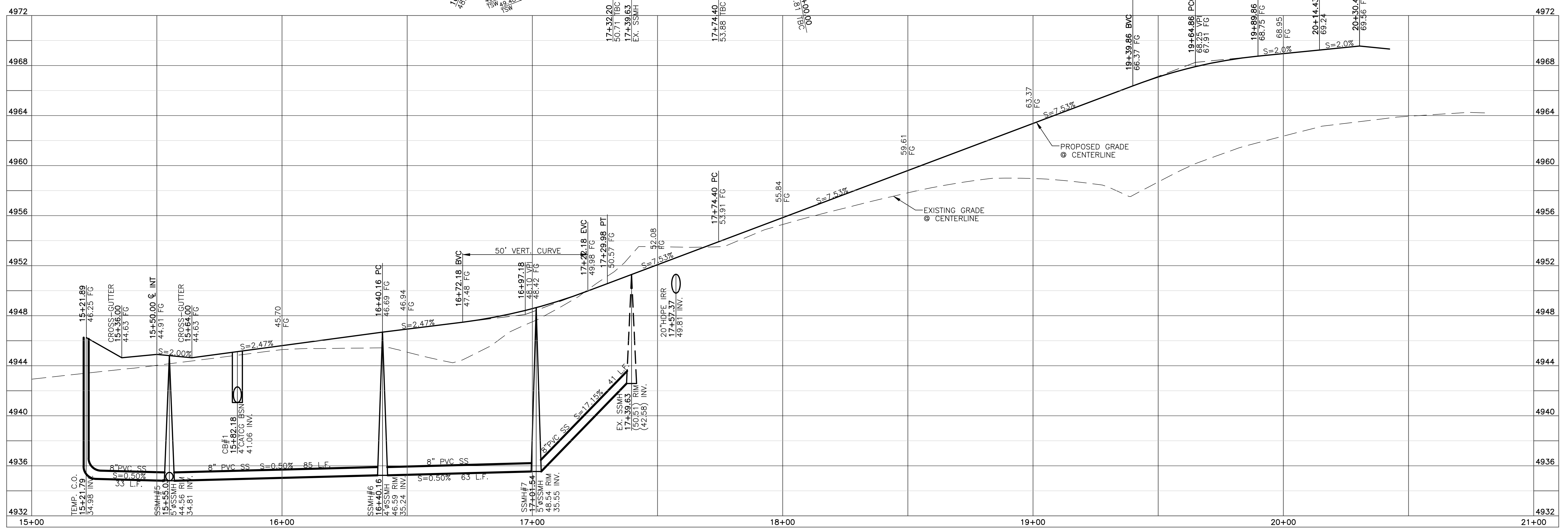

Reeve & Associates, Inc. - Solutions You Can Build On

Revised 10-21-13

Reeve & Associates, Inc. - Solutions You Can Build On

**Edgewater Beach Resort**  
**Phase-1**  
 WEBER COUNTY, UTAH  
**Edgewater Court**  
**15+00.00 - 21+00.00**

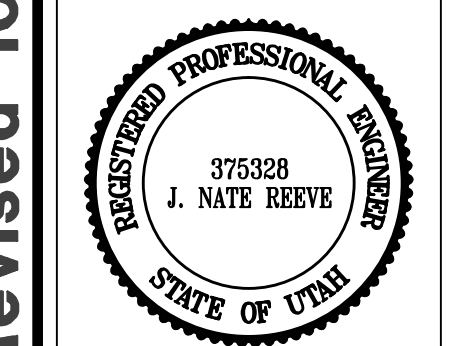

**Project Info.**  
 Engineer: J. NATE REEVE, P.E.  
 Drafter: R. HANSEN  
 Begin Date: JULY 09, 2012  
 Name: EDGEWATER BEACH RESORT PHASE-1  
 Number: 5917-15

Sheet **12**  
 5 Sheets

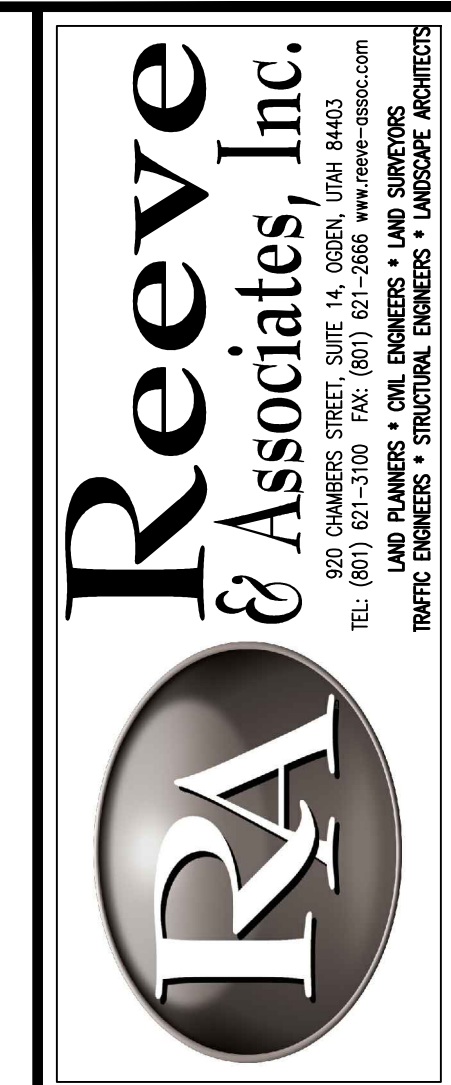

**REVISIONS**

DATE	DESCRIPTION
7-31-12	RH Design Complete
3-18-13	CA Design Complete
6-21-13	RH Co. Eng. Review
7-3-13	RH Co. Eng. Review
8-16-13	RH Co. Eng. Review
9-19-13	RH Co. Eng. Review
10-21-13	RH Sewer Revisions



Table with 2 columns: DATE, DESCRIPTION. Lists revision dates and descriptions for the project.

Edgewater Beach Resort Phase-1 Grading Plan

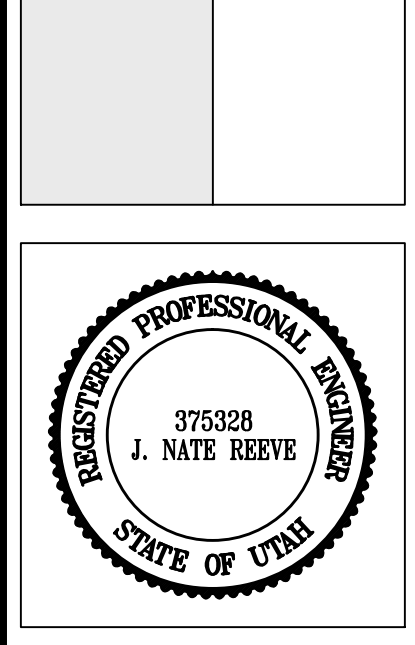

Project Info.
Engineer: J. NATE REEVE, P.E.
Drafted: R. HANSEN
Begin Date: JULY 09, 2012
Name: EDGEWATER BEACH RESORT PHASE-1
Number: 5917-15



Note:
1) ALL RESIDENTIAL UNITS EXCEPT EXISTING CONDOMINIUMS HAVE A BASEMENT
2) ALL SIDEWALKS ARE 4' WIDE UNLESS OTHERWISE NOTED.
3) CONTRACTOR TO SLOPE GROUND AWAY FROM ALL BUILDINGS AT A MINIMUM SLOPE OF 2% FOR 10 FEET.

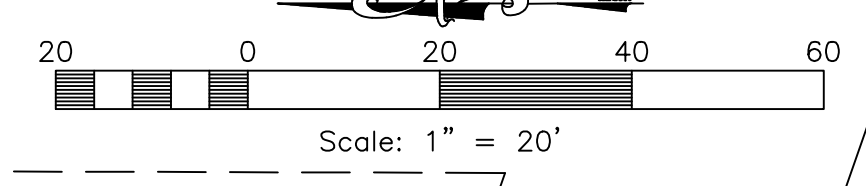
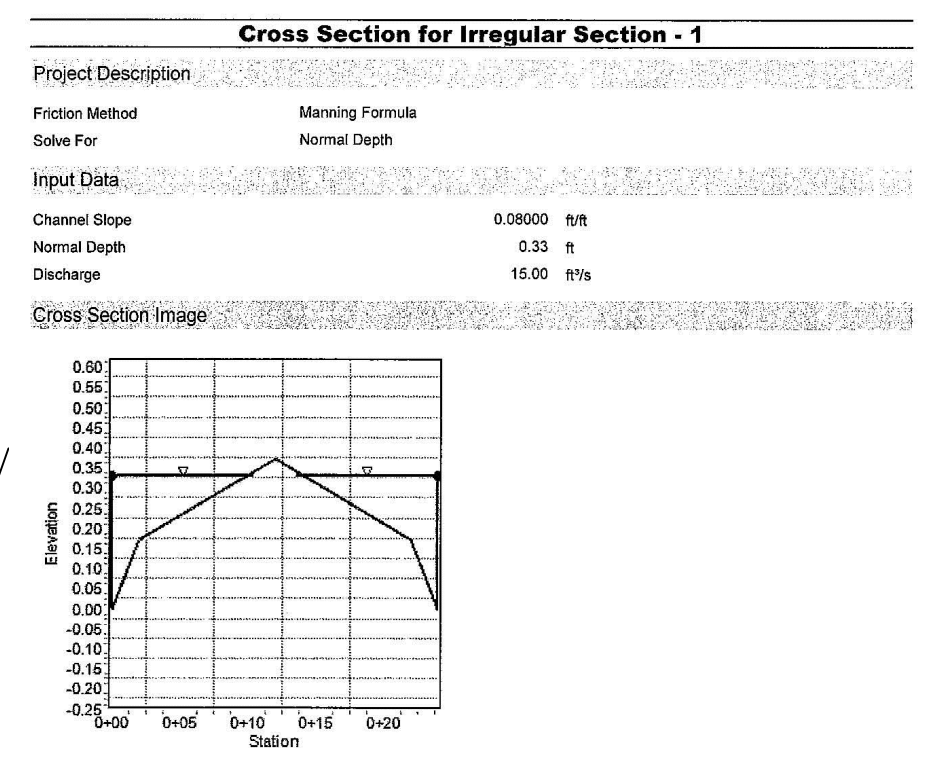



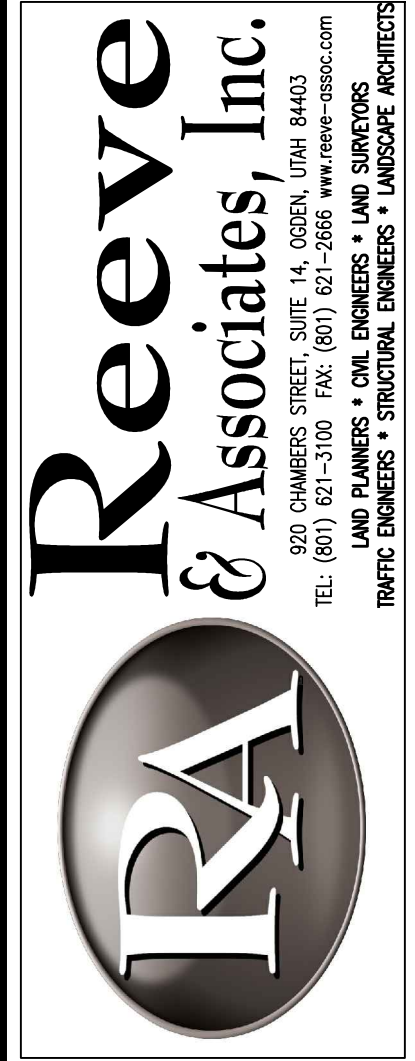
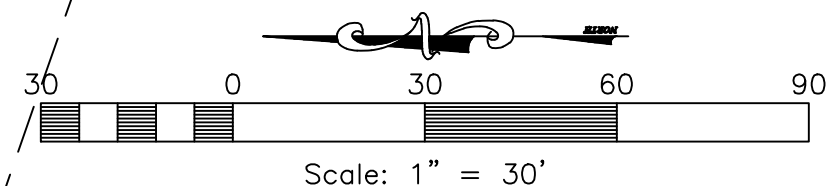
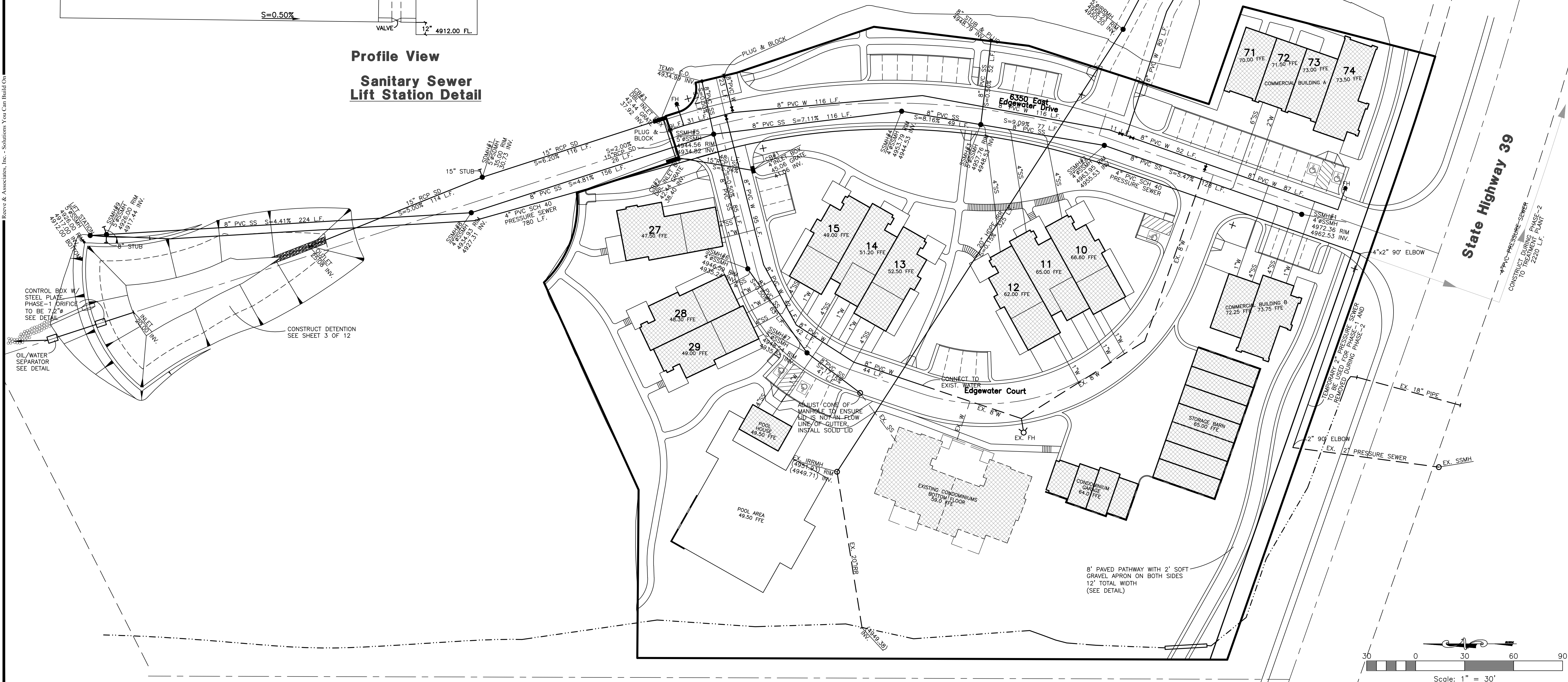
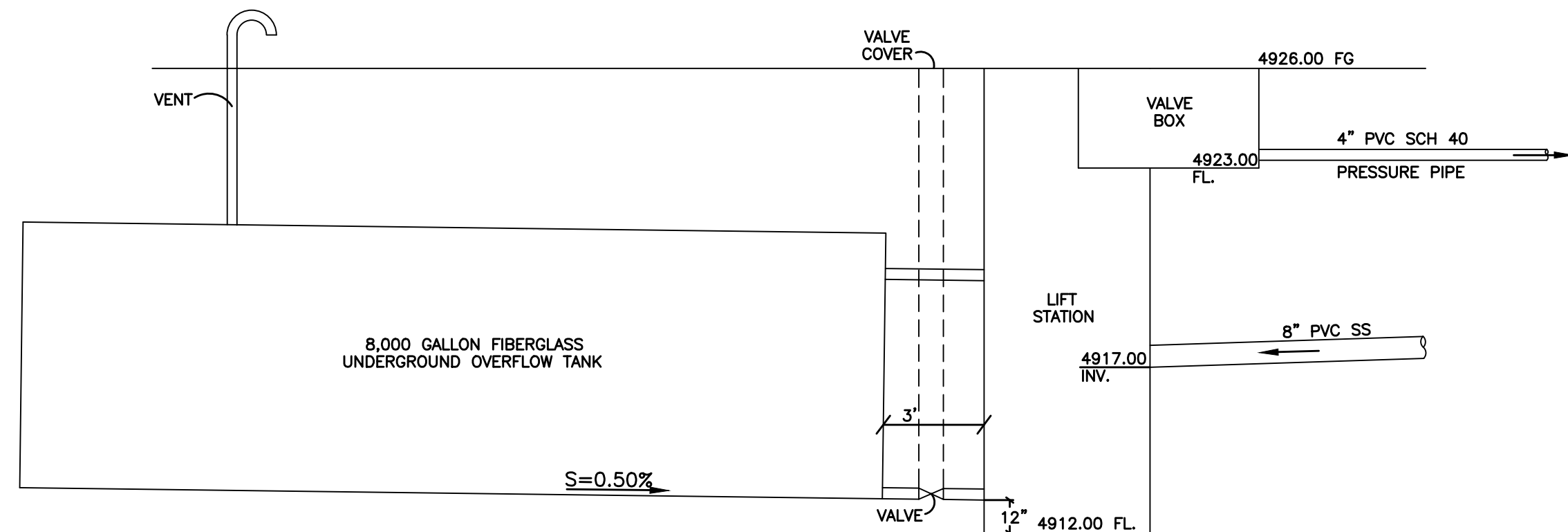
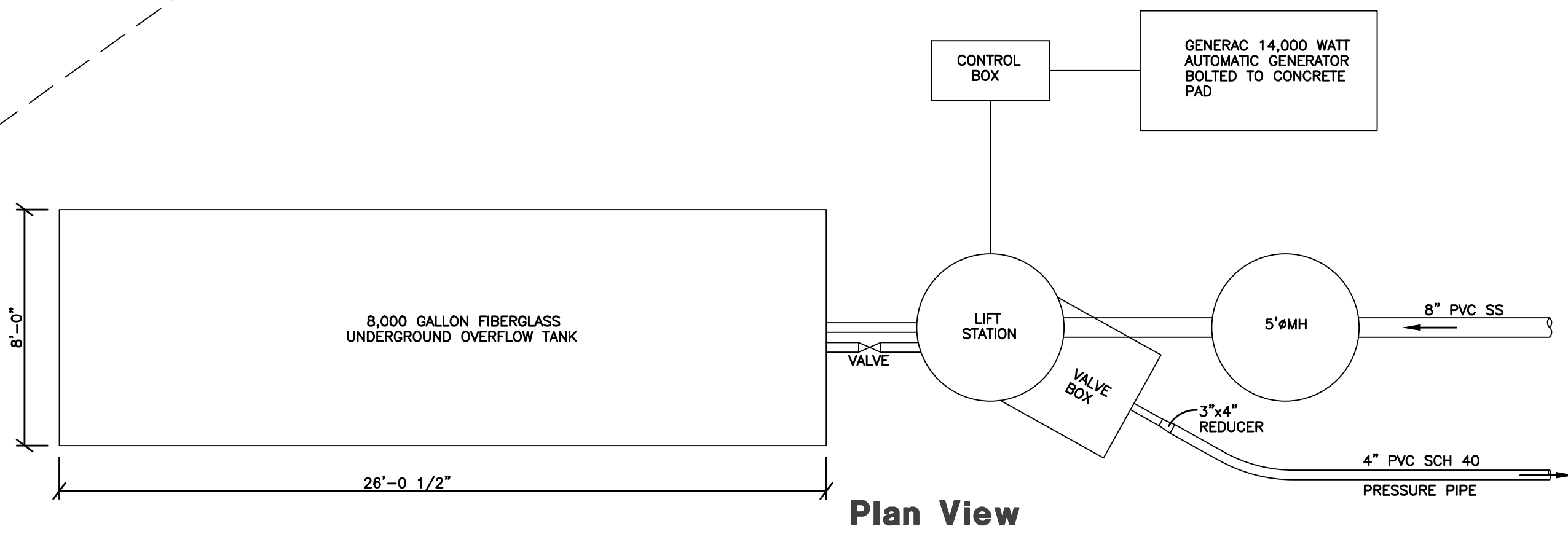

REVISIONS	DATE	DESCRIPTION
7-31-12	RH	Design Complete
3-14-13	CA	Design Complete
6-21-13	RH	Co. Eng. Review
7-3-13	RH	Co. Eng. Review
8-16-13	RH	Co. Eng. Review
9-19-13	RH	Co. Eng. Review
10-21-13	RH	Sewer Revisions

**Edgewater Beach Resort  
Phase-1  
Webster County, Utah**

**Utility Plan**

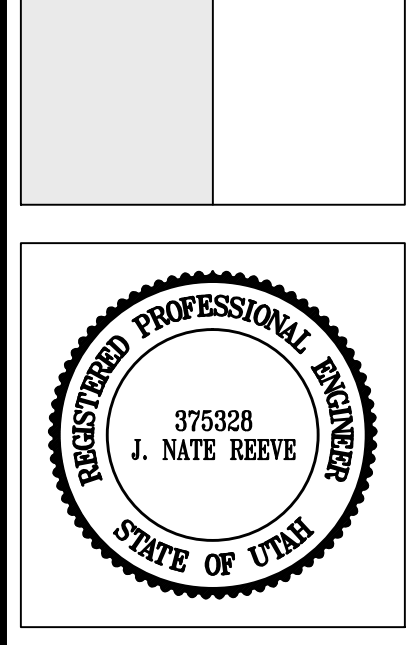

**Project Info.**  
 Engineer: J. NATE REEVE, P.E.  
 Drafter: R. HANSEN  
 Begin Date: JULY 09, 2012  
 Name: EDGEWATER BEACH RESORT PHASE-1  
 Number: 5917-15

Sheet **7** of **12** Sheets



### Storm Runoff Calculations

#### Edgewater Estates-Phase 1

7/31/2012  
The following runoff calculations are based on the Rainfall - Intensity - Duration Frequency Curve for the Huntsville, UT area taken from data compiled by NOAA Atlas14, using a 100 year storm.

Runoff storm water has been calculated for two different sets of conditions, one being the existing undeveloped land and the other with land fully improved. The difference between the two quantities will be detained in a holding pond. All water that runs off and over the property at present will be diverted into the holding pond and released at a reduced rate into the existing drainage system.

The calculations are as follows:

1. Runoff from the undeveloped existing land.			
Runoff Coefficient	C =	0.2	
Rainfall Intensity	i =	3.20 IN./HR.	
Runoff Quantity	Q =	CIA	
Acres	A =	3.80 ACRES	
Q(out) = C*I*A =		2.43 CFS	

2. Runoff from developed land			
Runoff Coefficients			
Paved Area	39,774	C = 0.9	
Landscaped Area	97,776	C = 0.2	
Roof	28,173	C = 0.8	
Weighted Runoff Coefficient		C = 0.47	
Rainfall Intensity	i =	varies with time	
Runoff Quantity	Q =	CIA	

3. Detention Basin		
Volume in	Q * t	
Volume out	2.43 * t	

The capacity of the detention basin is calculated as the maximum difference between the volume flowing in and the volume flowing out.

The outflow from the detention basin is limited to outflow if undeveloped.  
Use 2.43 cfs for Q outflow

The required volume of the detention basin is 5,917 cubic feet

USE A 7.2 INCH DIAMETER ORIFICE AT OUTLET

#### DETENTION BASIN

Cumulative Volume For Detention Pond	
Edgewater Estates-Phase 1	
C =	0.47
A =	3.80
Q(out) =	2.43

time (min)	time (sec)	i (in./hr.)	Q (cfs)	Vol. in (cf)	Vol. out (cf)	Difference (cf)
0	0	0.00	0.00	0.00	0.00	0.00
5	300	7.55	13.50	4050.08	730.46	3319.62
10	600	5.75	10.28	6168.99	1460.92	4708.07
15	900	4.75	8.49	7844.18	2191.38	5452.80
30	1800	3.20	5.72	10299.53	4382.76	5916.77
60	3600	1.98	3.54	12745.67	8765.51	3980.16
120	7200	1.14	2.04	14876.93	17531.03	-2854.20
180	10800	0.79	1.41	15198.24	26296.54	-11098.30
360	21600	0.44	0.79	17110.10	52593.08	-35482.99
1440	86400	0.16	0.29	24718.87	210372.34	-185653.46

Huntsville, UT  
NOAA Atlas 14

### Storm Runoff Calculations

#### Edgewater Estates-Full

7/31/2012  
The following runoff calculations are based on the Rainfall - Intensity - Duration Frequency Curve for the Huntsville, UT area taken from data compiled by NOAA Atlas14, using a 100 year storm.

Runoff storm water has been calculated for two different sets of conditions, one being the existing undeveloped land and the other with land fully improved. The difference between the two quantities will be detained in a holding pond. All water that runs off and over the property at present will be diverted into the holding pond and released at a reduced rate into the existing drainage system.

The calculations are as follows:

1. Runoff from the undeveloped existing land.			
Runoff Coefficient	C =	0.2	
Rainfall Intensity	i =	3.20 IN./HR.	
Runoff Quantity	Q =	CIA	
Acres	A =	13.02 ACRES	
Q(out) = C*I*A =		8.34 CFS	

2. Runoff from developed land			
Runoff Coefficients			
Paved Area	135,807	C = 0.9	
Landscaped Area	334,282	C = 0.2	
Roof	97,276	C = 0.8	
Weighted Runoff Coefficient		C = 0.47	
Rainfall Intensity	i =	varies with time	
Runoff Quantity	Q =	CIA	

3. Detention Basin		
Volume in	Q * t	
Volume out	8.34 * t	

The capacity of the detention basin is calculated as the maximum difference between the volume flowing in and the volume flowing out.

The outflow from the detention basin is limited to outflow if undeveloped.  
Use 8.34 cfs for Q outflow

The required volume of the detention basin is 20,288 cubic feet

USE A 13.3 INCH DIAMETER ORIFICE AT OUTLET

#### DETENTION BASIN

Cumulative Volume For Detention Pond	
Edgewater Estates-Full	
C =	0.47
A =	13.02
Q(out) =	8.34

time (min)	time (sec)	i (in./hr.)	Q (cfs)	Vol. in (cf)	Vol. out (cf)	Difference (cf)
0	0	0.00	0.00	0.00	0.00	0.00
5	300	7.55	46.26	13878.25	2500.78	11377.46
10	600	5.75	35.23	21139.05	5001.56	16137.49
15	900	4.75	29.10	26194.04	7502.35	18691.69
30	1800	3.20	19.61	35293.02	15004.69	20288.33
60	3600	1.98	12.13	43675.12	30009.39	13665.73
120	7200	1.14	6.99	50292.56	60018.78	-9726.22
180	10800	0.79	4.82	52079.27	90028.17	-37948.90
360	21600	0.44	2.71	58630.54	180056.33	-121425.79
1440	86400	0.16	0.98	84703.26	720225.32	-635522.06

Huntsville, UT  
NOAA Atlas 14

#### Worksheet for Irregular Section - 1

Project Description  
Friction Method Manning Formula  
Solve For Normal Depth

Input Data  
Channel Slope 0.0500 ft/ft  
Discharge 5.72 ft<sup>3</sup>/s  
Section Definitions  
Station (ft) Elevation (ft)

0+00	0.00
0+01	0.50
0+01	0.00
0+13	0.24

Roughness Segment Definitions  
Start Station Ending Station Roughness Coefficient

(0+00, 0.00)	(0+13, 0.24)	0.016
--------------	--------------	-------

Options  
Current roughness vvegnac Pavlovski's Method  
Open Channel Weighting Method Pavlovski's Method  
Closed Channel Weighting Method Pavlovski's Method

Normal Depth	0.22 ft
Elevation Range	0.00 to 0.50 ft
Flow Area	1.23 ft <sup>2</sup>
Wetted Perimeter	11.73 ft
Hydraulic Radius	0.11 ft
Top Width	11.33 ft
Normal Depth	0.22 ft
Critical Depth	0.31 ft
Critical Slope	0.00998 ft/ft

#### Worksheet for Irregular Section - 1

Results  
Velocity 4.64 ft/s  
Velocity Head 0.33 ft  
Specific Energy 0.55 ft  
Froude Number 2.48  
Flow Type Supercritical

GVF Input Data  
Downstream Depth 0.00 ft  
Length 0.00 ft  
Number Of Steps 0

GVF Output Data  
Upstream Depth 0.00 ft  
Profile Description  
Profile Headloss 0.00 ft  
Downstream Velocity Infinity ft/s  
Upstream Velocity Infinity ft/s  
Normal Depth 0.22 ft  
Critical Depth 0.31 ft  
Channel Slope 0.05000 ft/ft  
Critical Slope 0.00998 ft/ft

#### Cross Section for Irregular Section - 1

Project Description  
Friction Method Manning Formula  
Solve For Normal Depth

Input Data  
Channel Slope 0.05000 ft/ft  
Normal Depth 0.22 ft  
Discharge 5.72 ft<sup>3</sup>/s

Cross Section Image

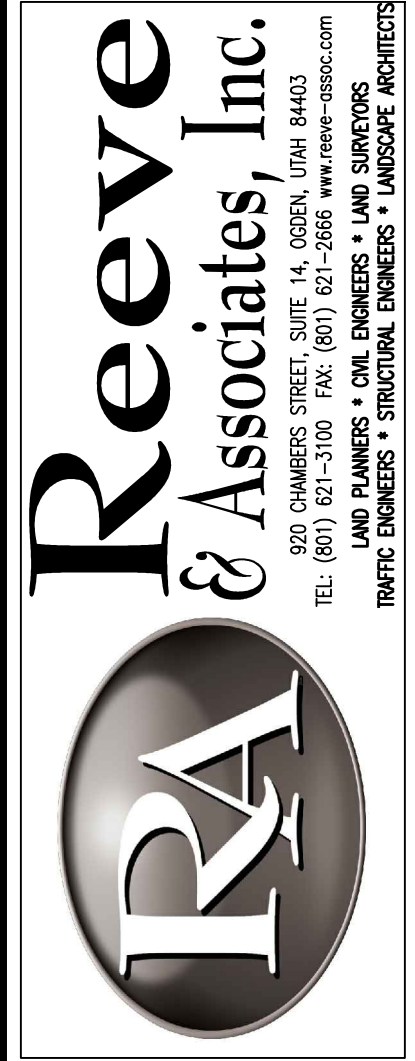
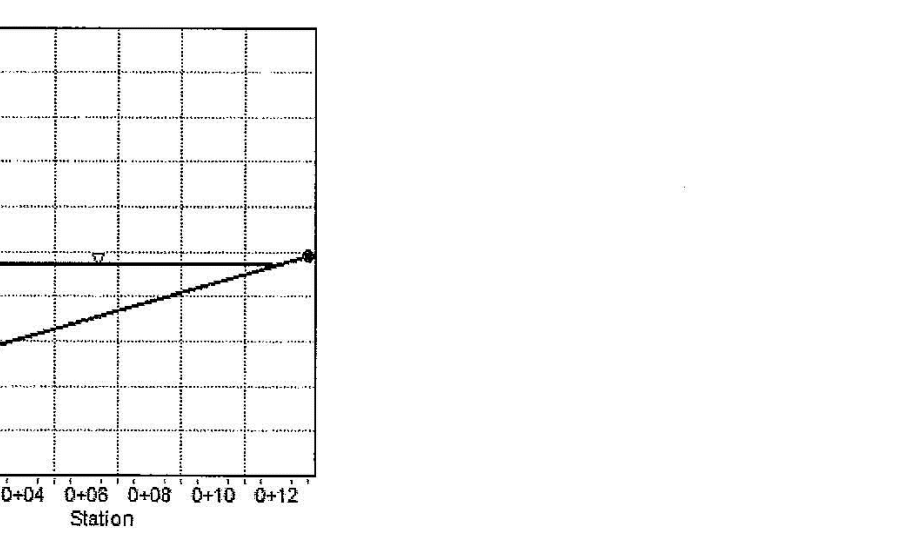

REVISIONS	DATE	DESCRIPTION
7-31-12	RH	Design Complete
8-14-13	CA	Design Complete
6-21-13	RH	Co. Eng. Review
7-3-13	RH	Co. Eng. Review
8-16-13	RH	Co. Eng. Review
9-19-13	RH	Co. Eng. Review
10-21-13	RH	Sewer Revisions

Edgewater Beach Resort  
Phase-1  
WEBER COUNTY, UTAH  
SD Calculations

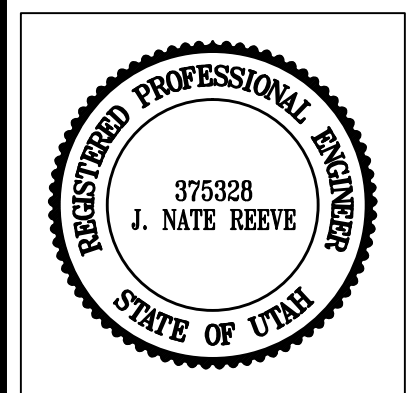

Project Info.  
Engineer: J. NATE REEVE, P.E.  
Drafter: R. HANSEN  
Begin Date: JULY 09, 2012  
Name: EDGEWATER BEACH RESORT PHASE-1  
Number: 5917-15

Revised 10-21-13



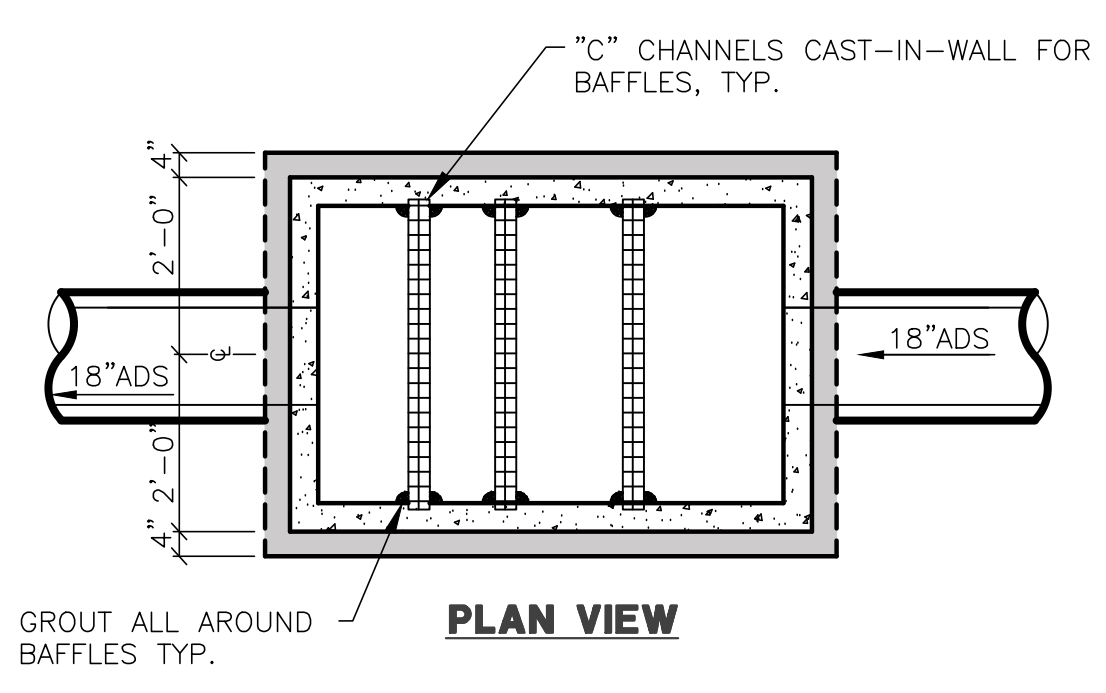

**PLAN VIEW**  
SCALE: NONE

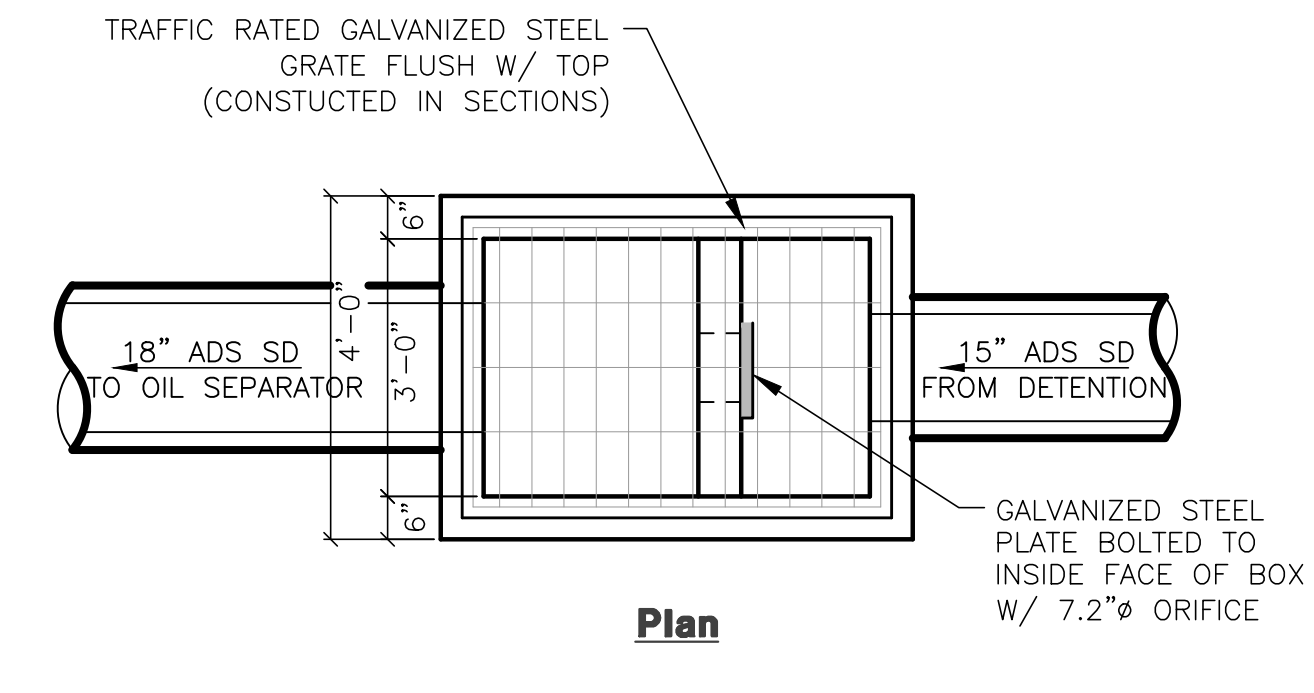

**Plan**  
SCALE: NONE

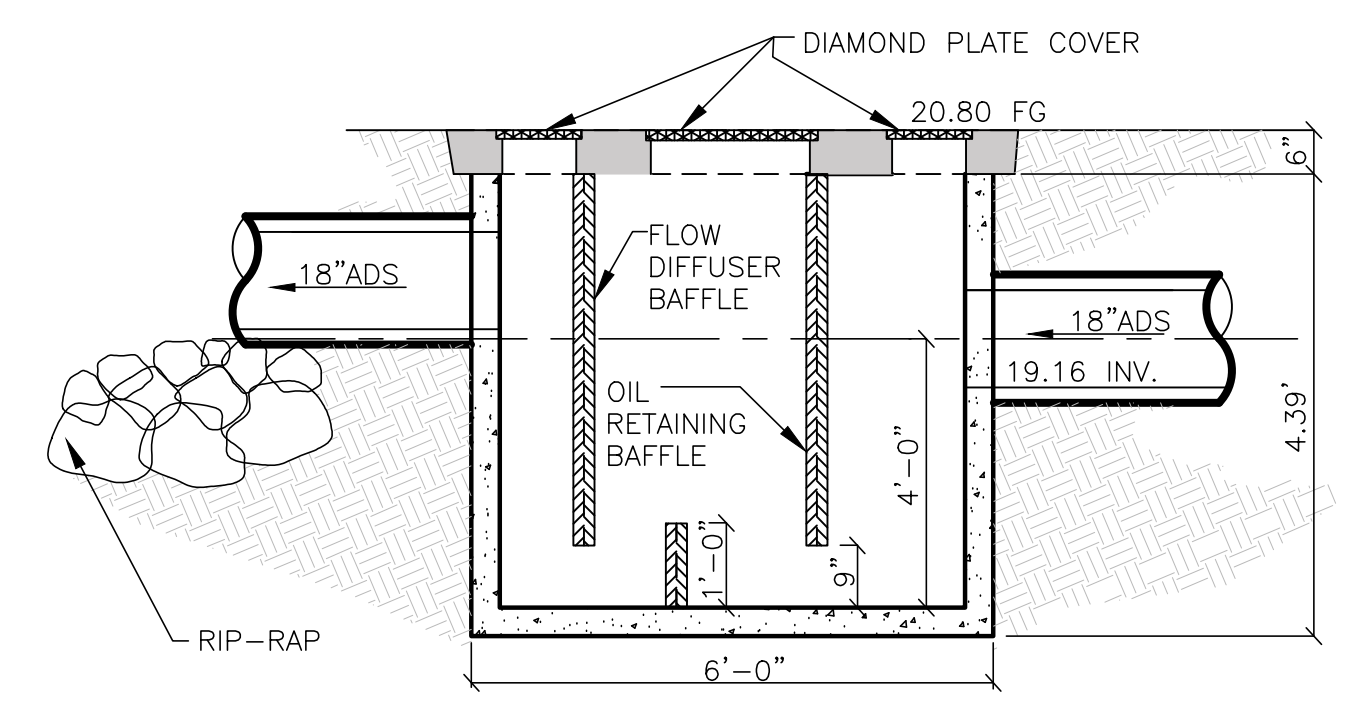

**Oil Separator**  
SCALE: NONE

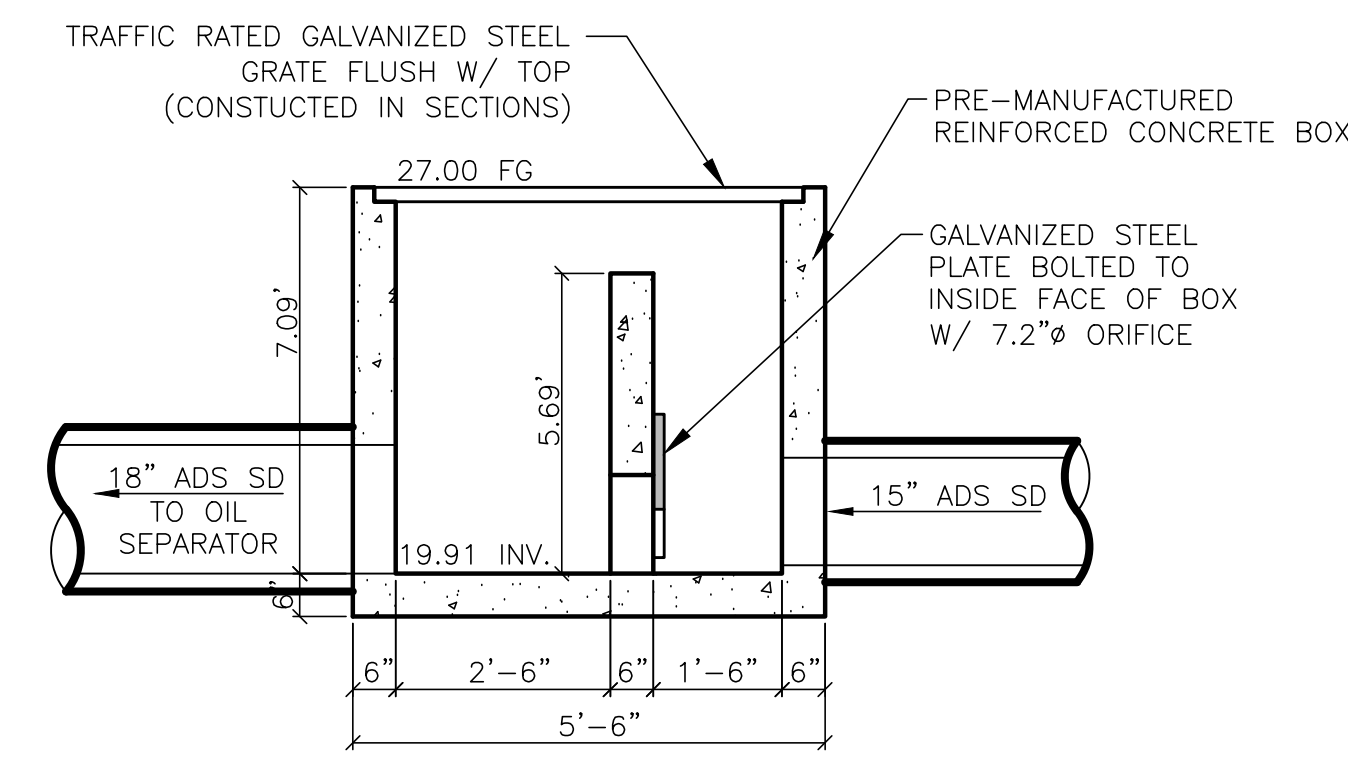

**Section**  
**Detention Basin Control Box**  
SCALE: NONE

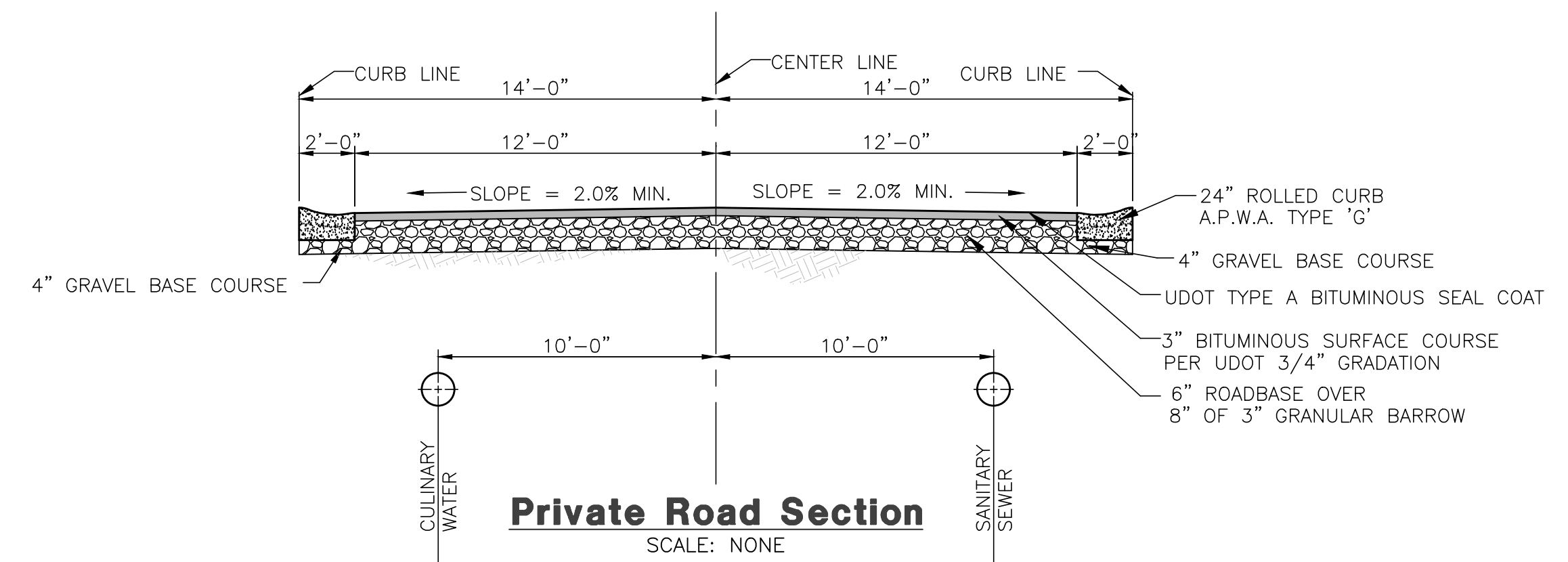

**Private Road Section**  
SCALE: NONE

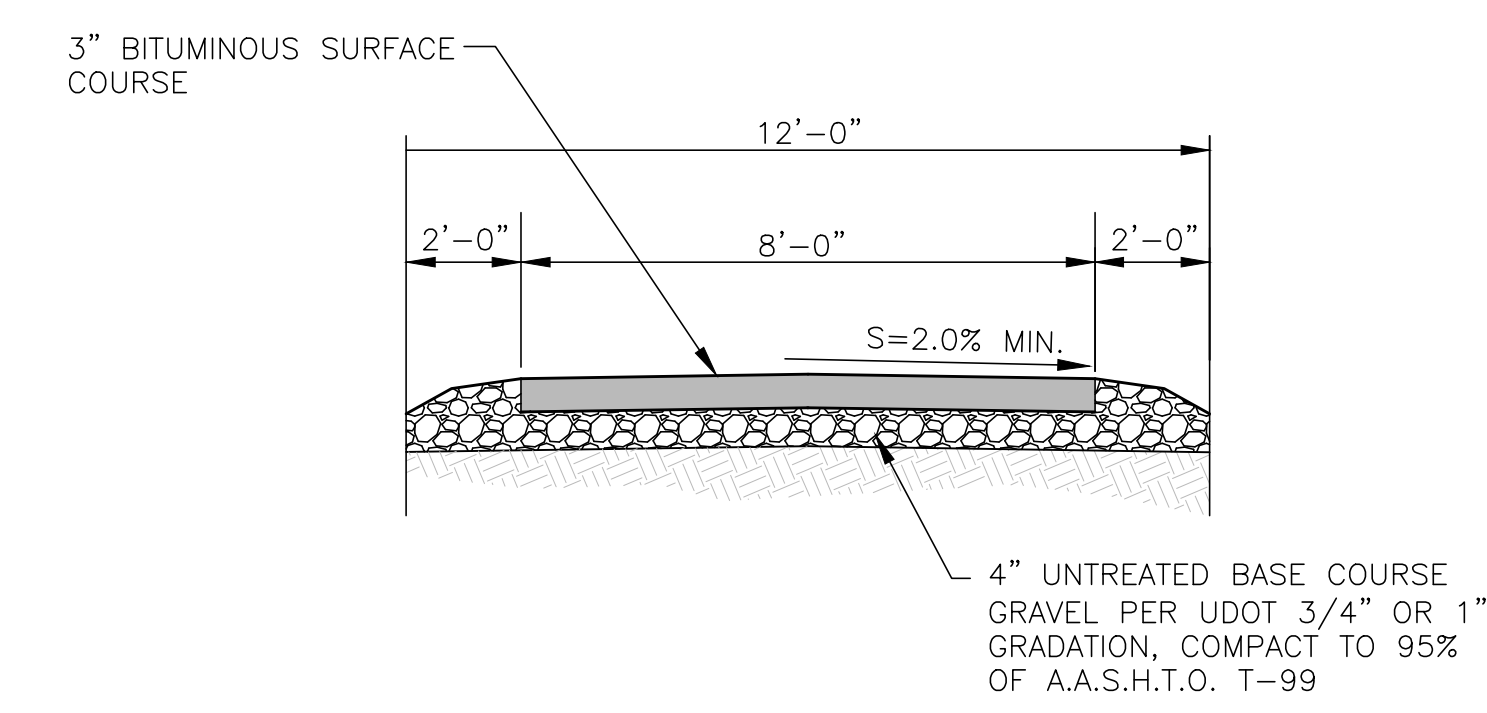

**Pathway Detail**  
SCALE: NONE

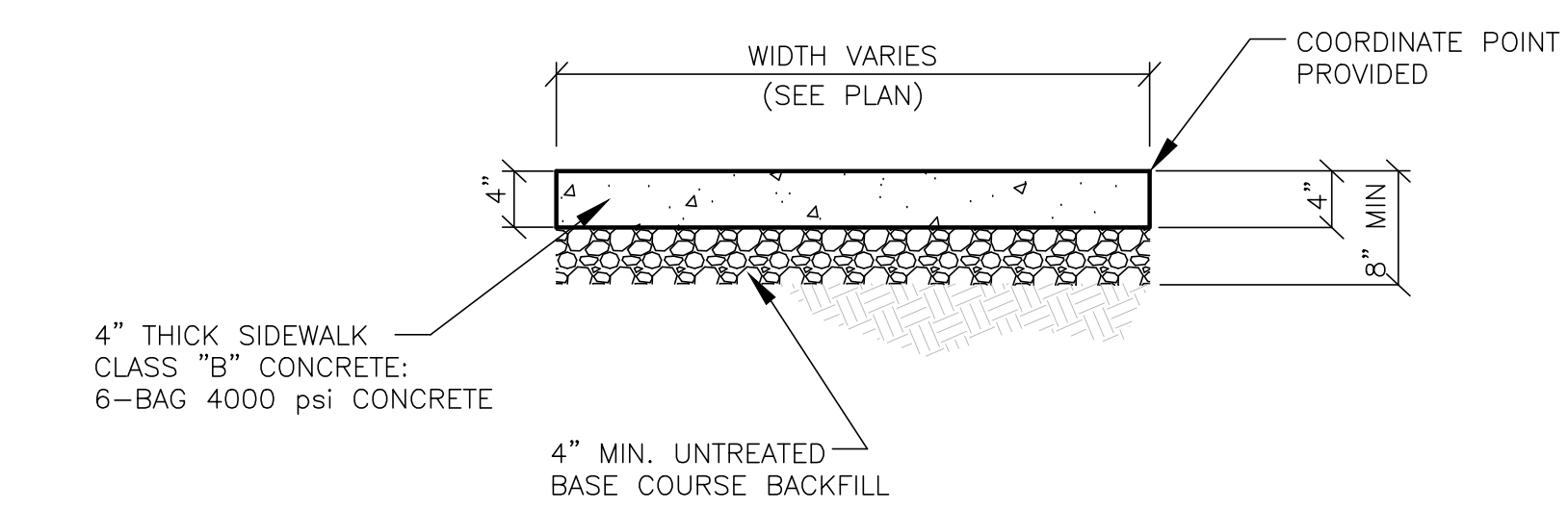

**Walkway Detail**  
SCALE: NONE  
(REFER TO SITE SPECIFIC GEOTECHNICAL REPORT)

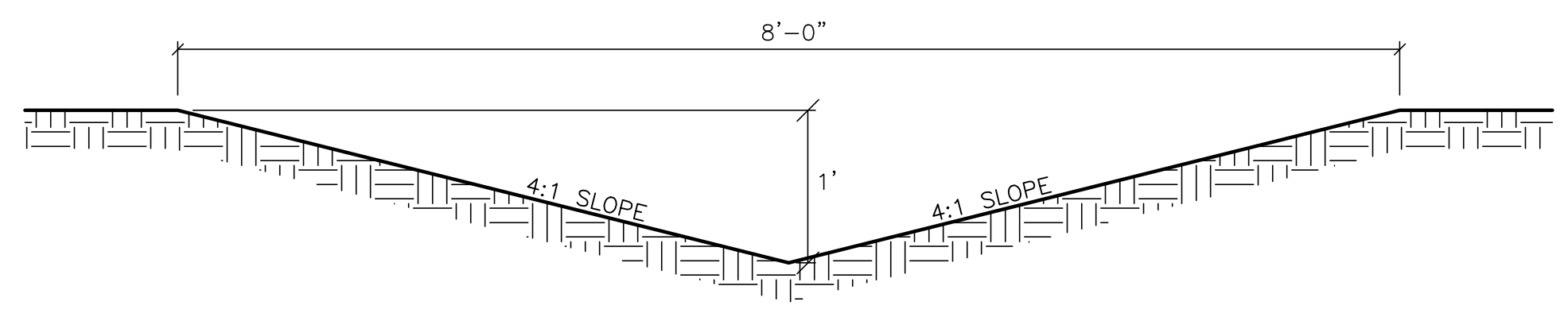

**Swale Detail**  
SCALE: NONE

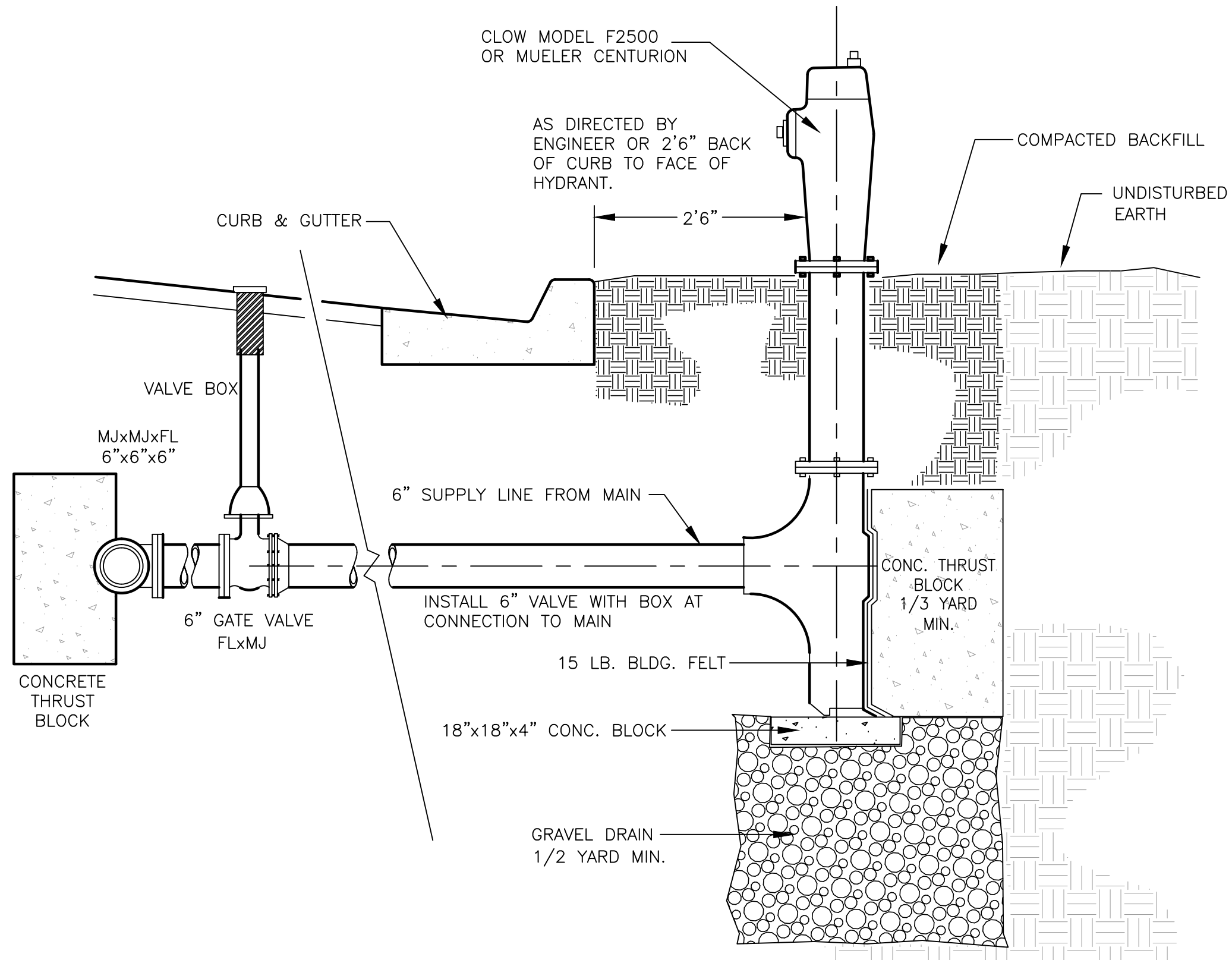

**Fire Hydrant Detail**  
SCALE: NONE

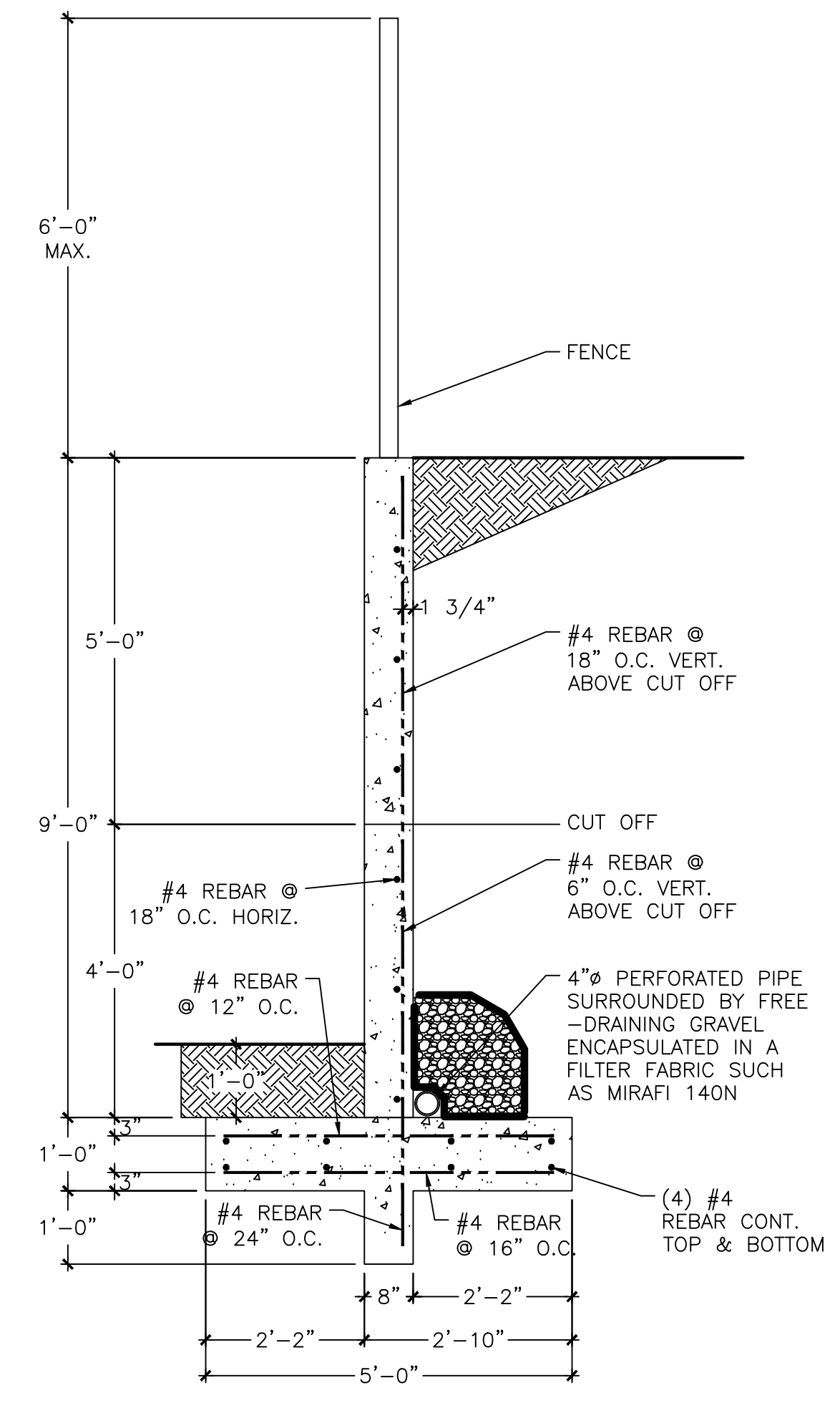

**6' to 8' Concrete Retaining Wall**  
SCALE: NONE

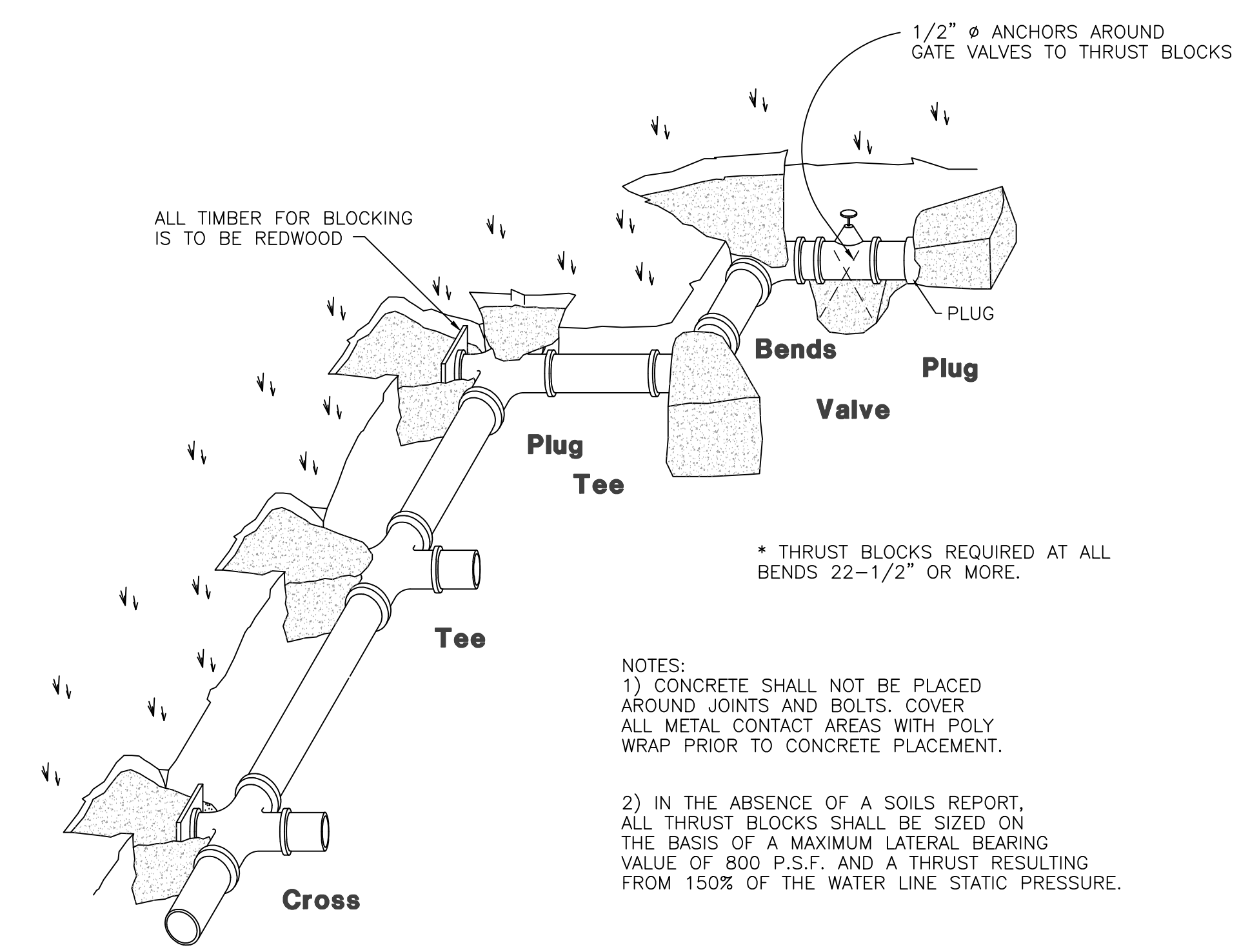

**Thrust Block Detail**  
SCALE: NONE

NOTES:  
1) CONCRETE SHALL NOT BE PLACED AROUND JOINTS AND BOLTS. COVER ALL METAL CONTACT AREAS WITH POLY WRAP PRIOR TO CONCRETE PLACEMENT.  
2) IN THE ABSENCE OF A SOILS REPORT, ALL THRUST BLOCKS SHALL BE SIZED ON THE BASIS OF A MAXIMUM LATERAL BEARING VALUE OF 800 P.S.F. AND A THRUST RESULTING FROM 150% OF THE WATER LINE STATIC PRESSURE.

**Reeve & Associates, Inc.**  
920 CHAMBERS STREET, SUITE #14, OGDEN, UTAH 84403  
TEL: (801) 921-3100 FAX: (801) 621-8666 www.reeve-assoc.com  
LAND PLANNERS • CIVIL ENGINEERS • LAND SURVEYORS  
TRAFFIC ENGINEERS • STRUCTURAL ENGINEERS • LANDSCAPE ARCHITECTS

REVISIONS	DATE	DESCRIPTION
7-31-12	RH	Design Complete
3-14-13	CA	Design Complete
6-21-13	RH	Co. Eng. Review
7-3-13	RH	Co. Eng. Review
8-16-13	RH	Co. Eng. Review
9-19-13	RH	Co. Eng. Review
10-21-13	RH	Sewer Revisions

**Edgewater Beach Resort Phase-1**  
WEBER COUNTY, UTAH  
**Civil Details**

Revised 10-21-13

**Project Info.**

Engineer:	J. NATE REEVE, P.E.
Drafter:	R. HANSEN
Begin Date:	JULY 09, 2012
Name:	EDGEWATER BEACH RESORT PHASE-1
Number:	5917-15

Sheet	12
9	Sheets



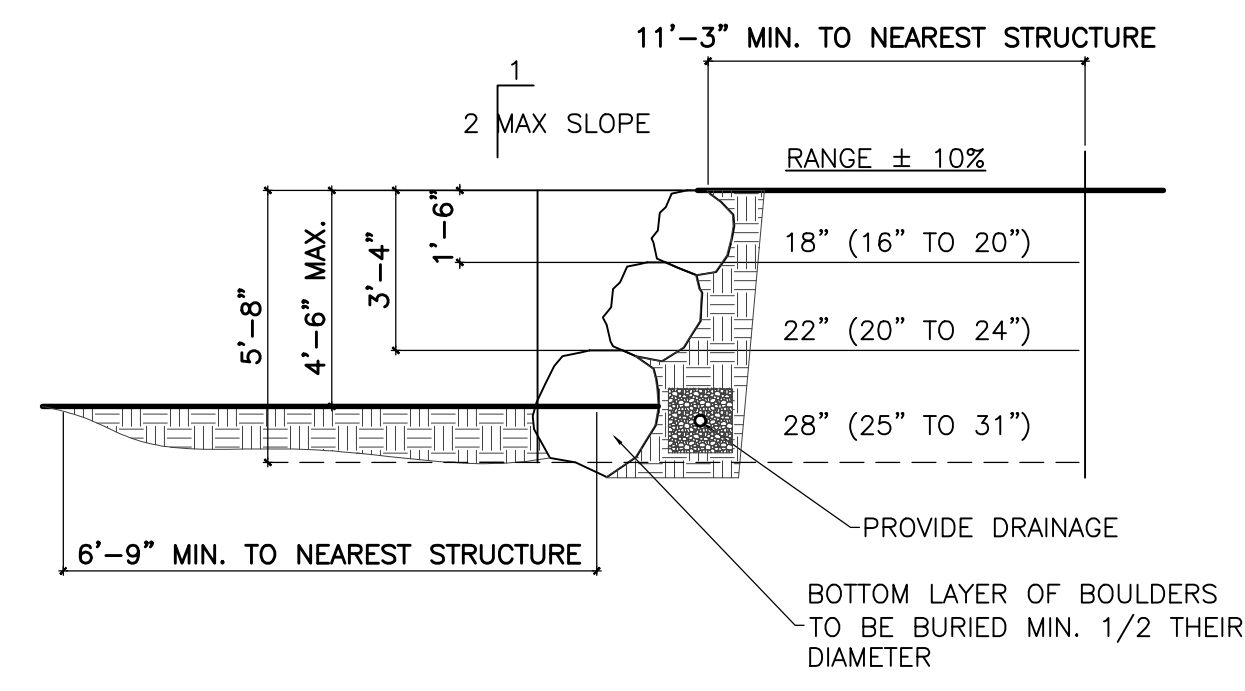

**4'-6" WALL CROSS SECTION**  
SCALE: NONE

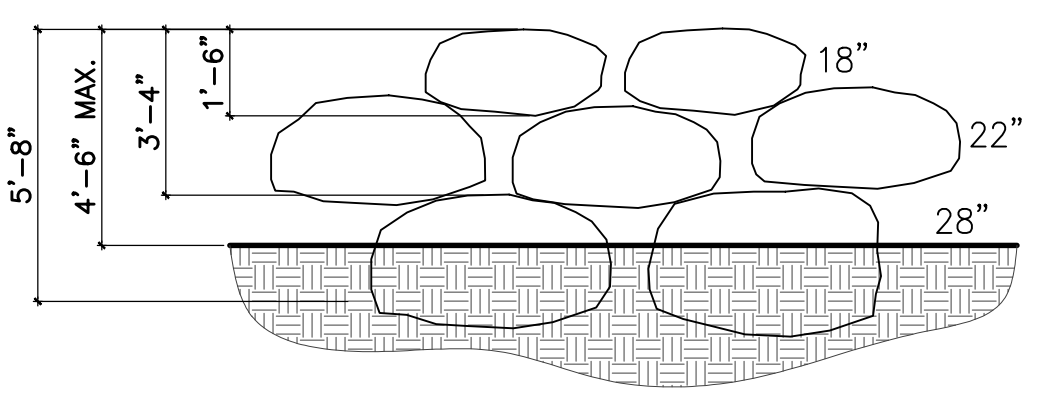

**4'-6" WALL FRONT ELEVATION**  
SCALE: NONE

**NOTE:**  
BOULDERS MUST BE KEYPED TOGETHER AND INTERLOCKED WITH ALL ADJOINING ROCKS

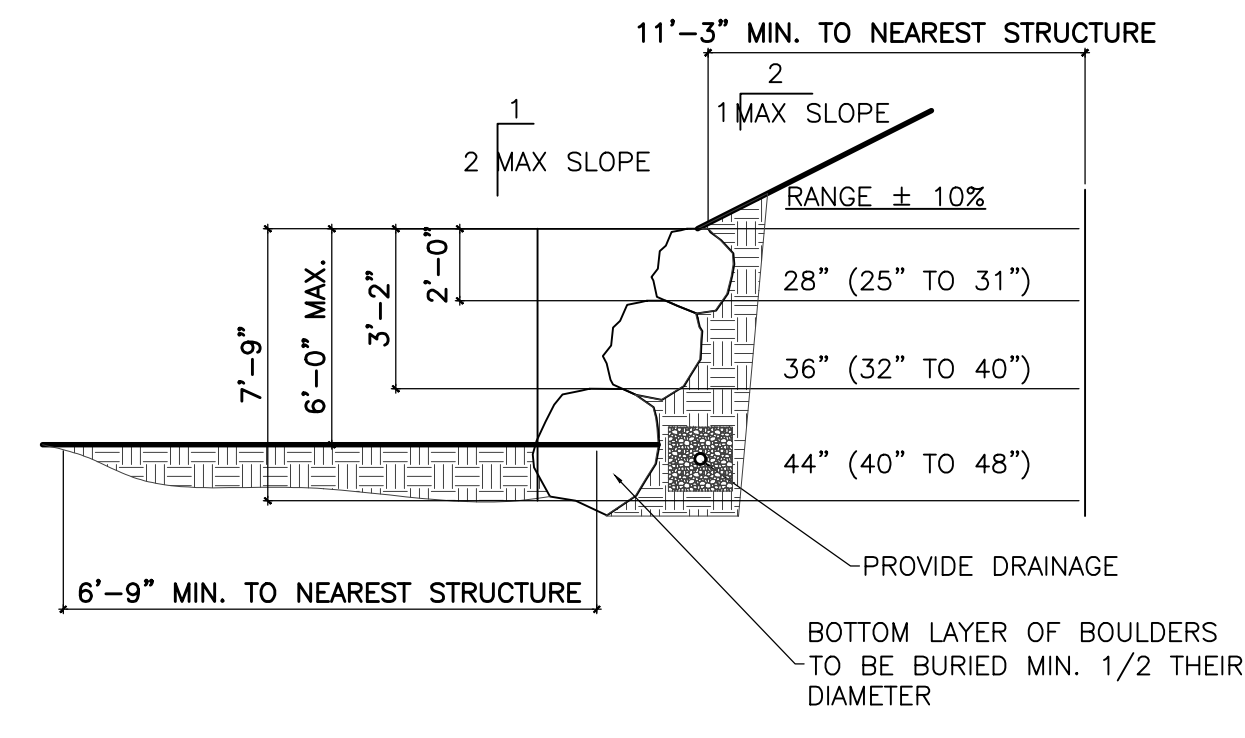

**6'-0" WALL CROSS SECTION**  
SCALE: NONE

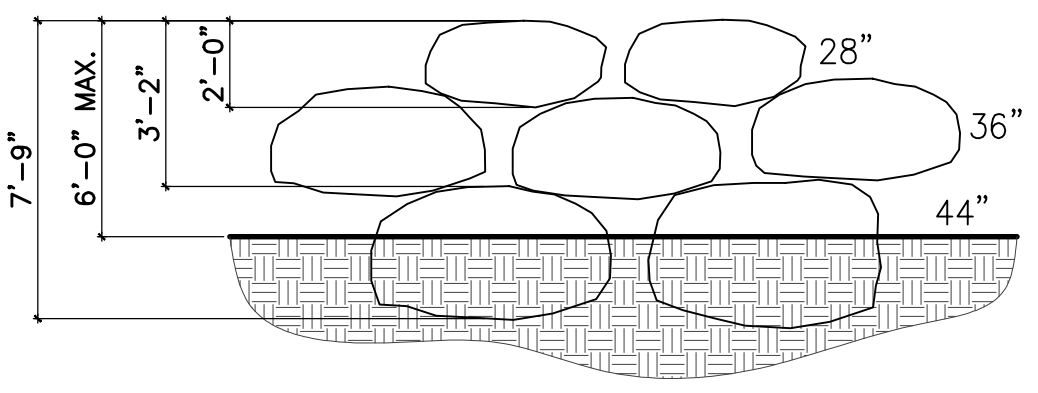

**6'-0" WALL FRONT ELEVATION**  
SCALE: NONE

**NOTE:**  
BOULDERS MUST BE KEYPED TOGETHER AND INTERLOCKED WITH ALL ADJOINING ROCKS

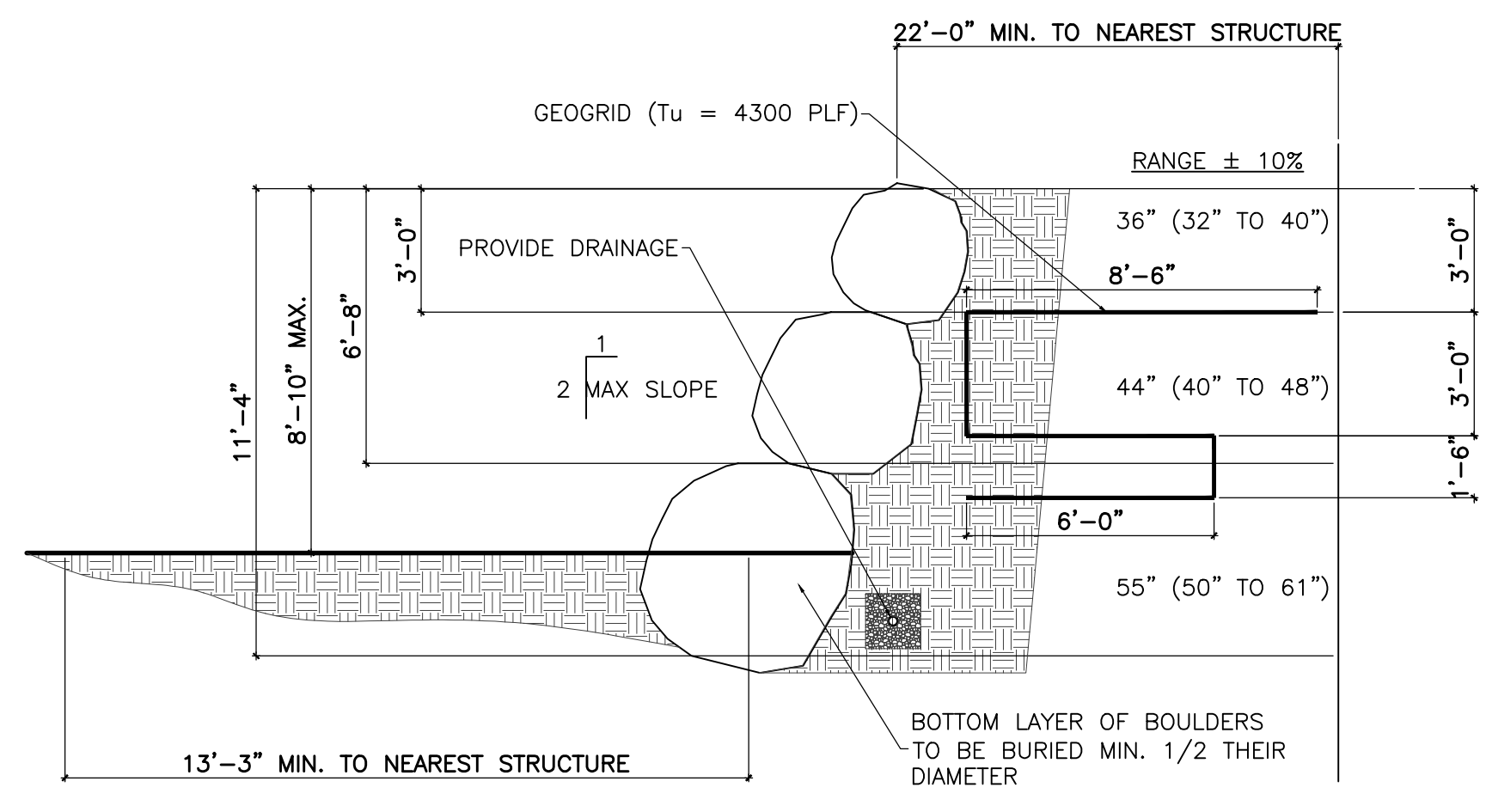

**8'-10" WALL CROSS SECTION**  
SCALE: NONE

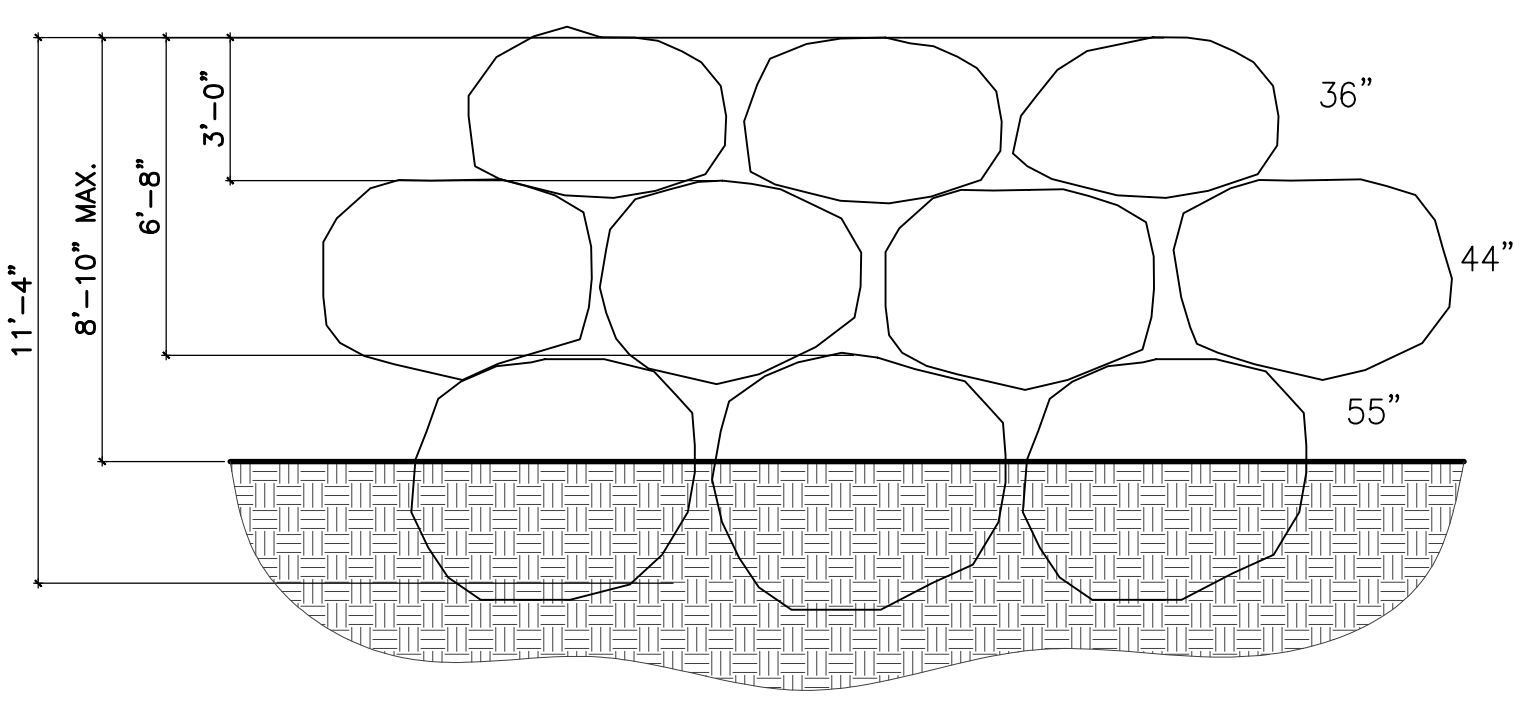

**8'-10" WALL FRONT ELEVATION**  
SCALE: NONE

**NOTE:**  
BOULDERS MUST BE KEYPED TOGETHER AND INTERLOCKED WITH ALL ADJOINING ROCKS

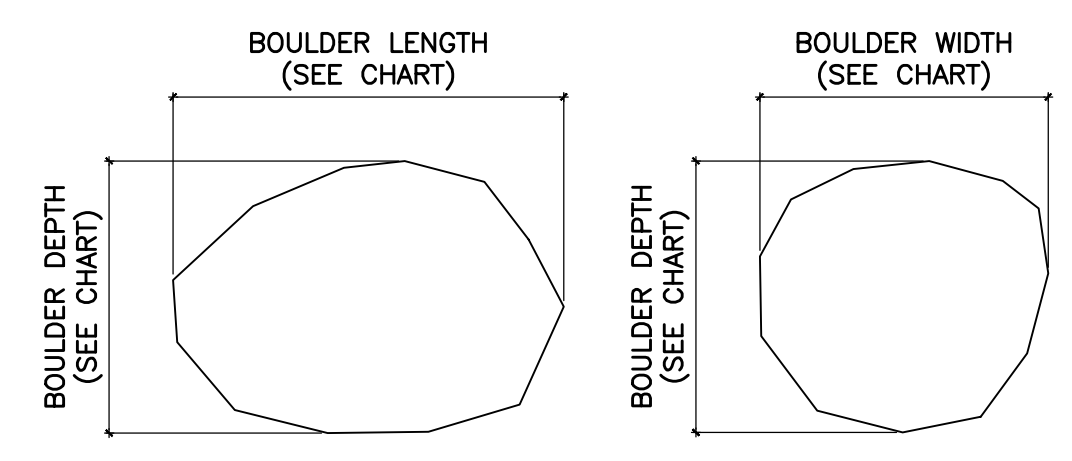

**BOULDER DIMENSION CHART**

BOULDER DEPTH	ALLOWABLE BOULDER LENGTH		ALLOWABLE BOULDER WIDTH	
	MINIMUM	MAXIMUM	MINIMUM	MAXIMUM
18"	12"	27"	12"	27"
22"	15"	33"	15"	33"
28"	19"	42"	19"	42"
36"	24"	54"	24"	54"
44"	29"	67"	29"	67"
55"	37"	83"	37"	83"

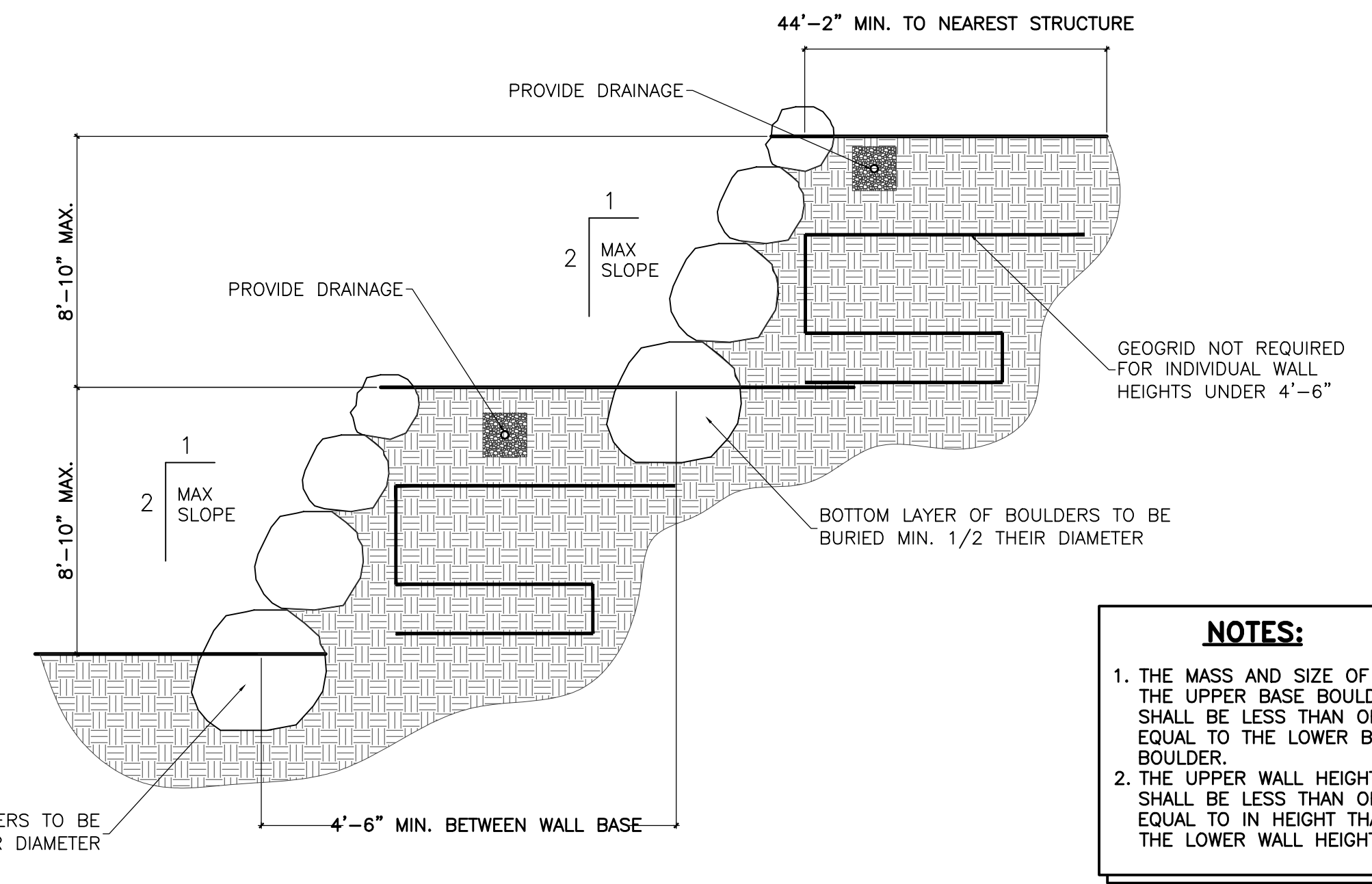

**CROSS SECTION OF MULTIPLIER WALL**  
SCALE: NONE

**NOTES:**  
1. THE MASS AND SIZE OF THE UPPER BASE BOULDER SHALL BE LESS THAN OR EQUAL TO THE LOWER BASE BOULDER.  
2. THE UPPER WALL HEIGHT SHALL BE LESS THAN OR EQUAL TO IN HEIGHT THAN THE LOWER WALL HEIGHT.

**INHERENT CHARACTERISTICS OF LARGE BOULDER RETAINING WALLS:**

1. LARGE BOULDER RETAINING WALLS **DO NOT** HAVE THE CAPACITY TO WITHSTAND SEISMIC EVENTS.
2. LARGE BOULDER RETAINING WALLS **DO NOT** HAVE THE CAPACITY TO WITHSTAND SATURATED SOILS.
3. THE RETAINED HEIGHT OF LARGE BOULDER RETAINING WALLS IS DIRECTLY RELATED TO THE AVAILABILITY AND WORKING CAPACITY OF THE BOULDERS TO BE USED IN THE WALL.
4. LARGE BOULDER RETAINING WALLS ARE NOT HOMOGENEOUS STRUCTURAL SYSTEMS. THEREFORE THEIR RETAINING CAPABILITY IS LIMITED AND UNPREDICTABLE.
5. THE STABILITY, STRUCTURAL INTEGRITY, AND LONGEVITY OF LARGE BOULDER RETAINING WALLS DEPENDS LARGELY ON HOW WELL THE WALL HAS BEEN CONSTRUCTED.
6. THE LARGE BOULDER RETAINING WALL DESIGN SHOWN IS LIMITED TO A MAXIMUM HEIGHT OF 8'-10".

**LARGE BOULDER RETAINING WALL NOTES:**

1. SUPPORT BOULDERS ARE TO BE 1.25x LARGER, BY MASS AS WELL AS BY SIZE, THAN THOSE POSITIONED IMMEDIATELY ABOVE.
2. BOULDER SIZES MAY NOT VARY MORE THAN PLUS OR MINUS 10% OF REQUIRED SIZES.
3. BOULDERS ARE TO MAKE CONTACT WITH ALL ADJOINING BOULDERS. THEY MUST BE KEYPED TOGETHER AND INTERLOCKED.
4. THE MAXIMUM SLOPE OF THE LARGE BOULDER RETAINING WALL SHALL NOT EXCEED A 1 TO 2 PITCH (1 HORIZONTAL UNIT PER 2 VERTICAL UNITS). SLOPE SHALL BE MEASURED FROM CENTER OF MASS OF EACH BOULDER.
5. THE BOTTOM COURSE OF BOULDERS ARE TO BE BURIED A MINIMUM DEPTH OF NOT LESS THAN 1/2 OF THEIR DIAMETER.
6. BOULDERS ARE TO BE PLACED SUCH THAT NO TWO ADJACENT JOINTS LINE UP WITH ONE ANOTHER IN THE VERTICAL DIRECTION.
7. BASE SOILS SHALL BE THOROUGHLY COMPACTED (90% PROCTOR) BEFORE BOULDERS ARE PLACED.
8. PROVIDE PROPER DRAINAGE AT EVERY THIRD BOULDER LAYER.
9. SOILS ARE ASSUMED TO HAVE AN ACTIVE PRESSURE NOT TO EXCEED 37 PSF.
10. PROVIDE MEANS TO MAINTAIN RANGE OF OPTIMUM MOISTURE CONTENT FOR EXISTING SOIL CONDITIONS.

REVISIONS	DATE	DESCRIPTION
7-31-12	RH	Design Complete
3-14-13	CA	Design Complete
6-21-13	RH	Co. Eng. Review
7-3-13	RH	Co. Eng. Review
8-16-13	RH	Co. Eng. Review
9-19-13	RH	Co. Eng. Review
10-21-13	RH	Sewer Revisions

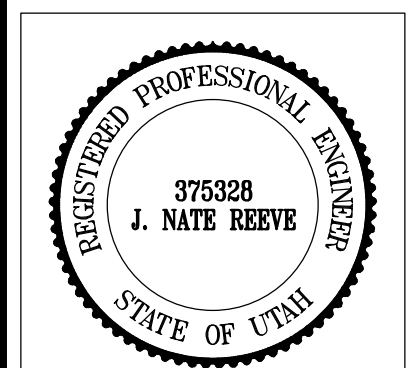

**Project Info.**

Engineer:	J. NATE REEVE, P.E.
Drafter:	R. HANSEN
Begin Date:	JULY 09, 2012
Name:	EDGEWATER BEACH RESORT PHASE-1
Number:	5917-15



# EDGEWATER ESTATES Phase-1 Storm Water Pollution Prevention Plan Exhibit

WEBER COUNTY, UTAH  
AUGUST 2013

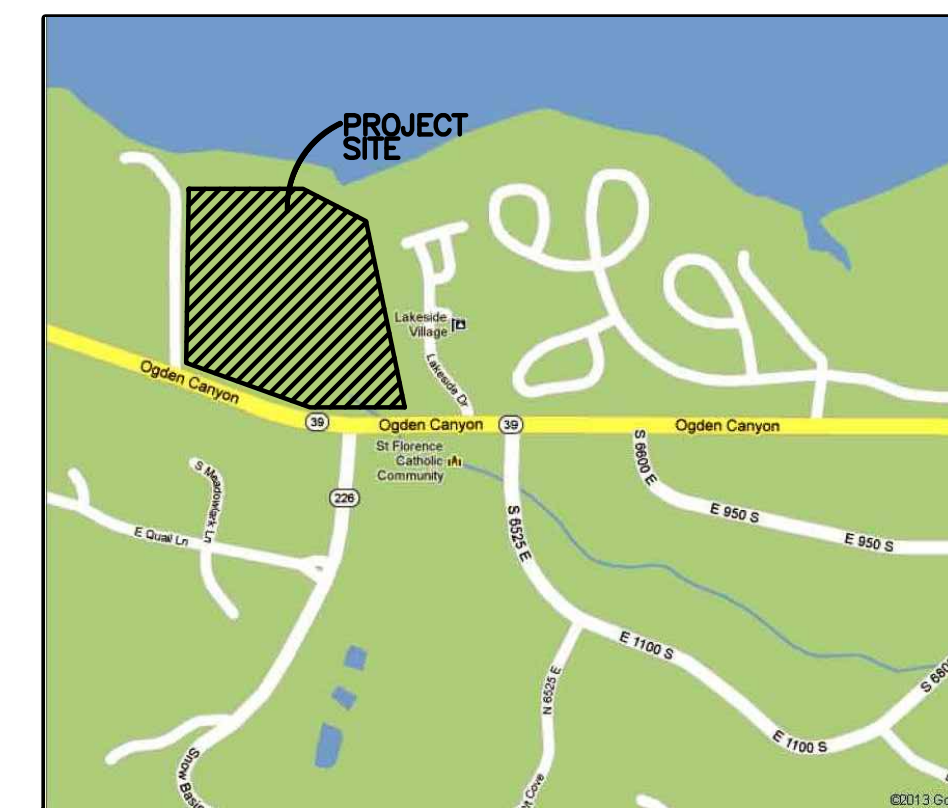

Vicinity Map  
NOT TO SCALE

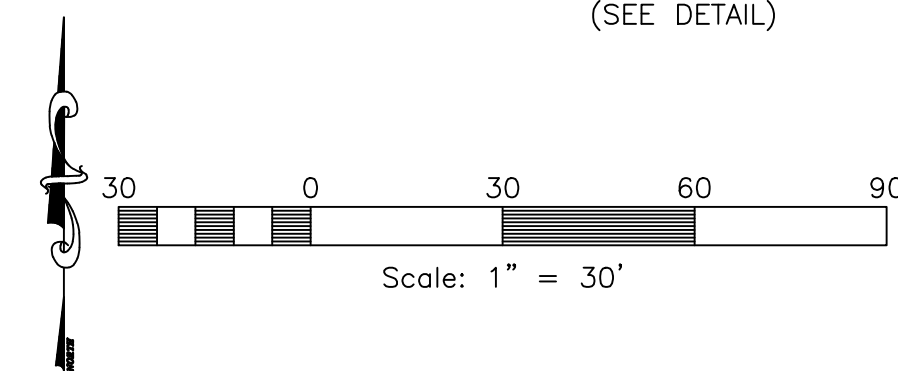
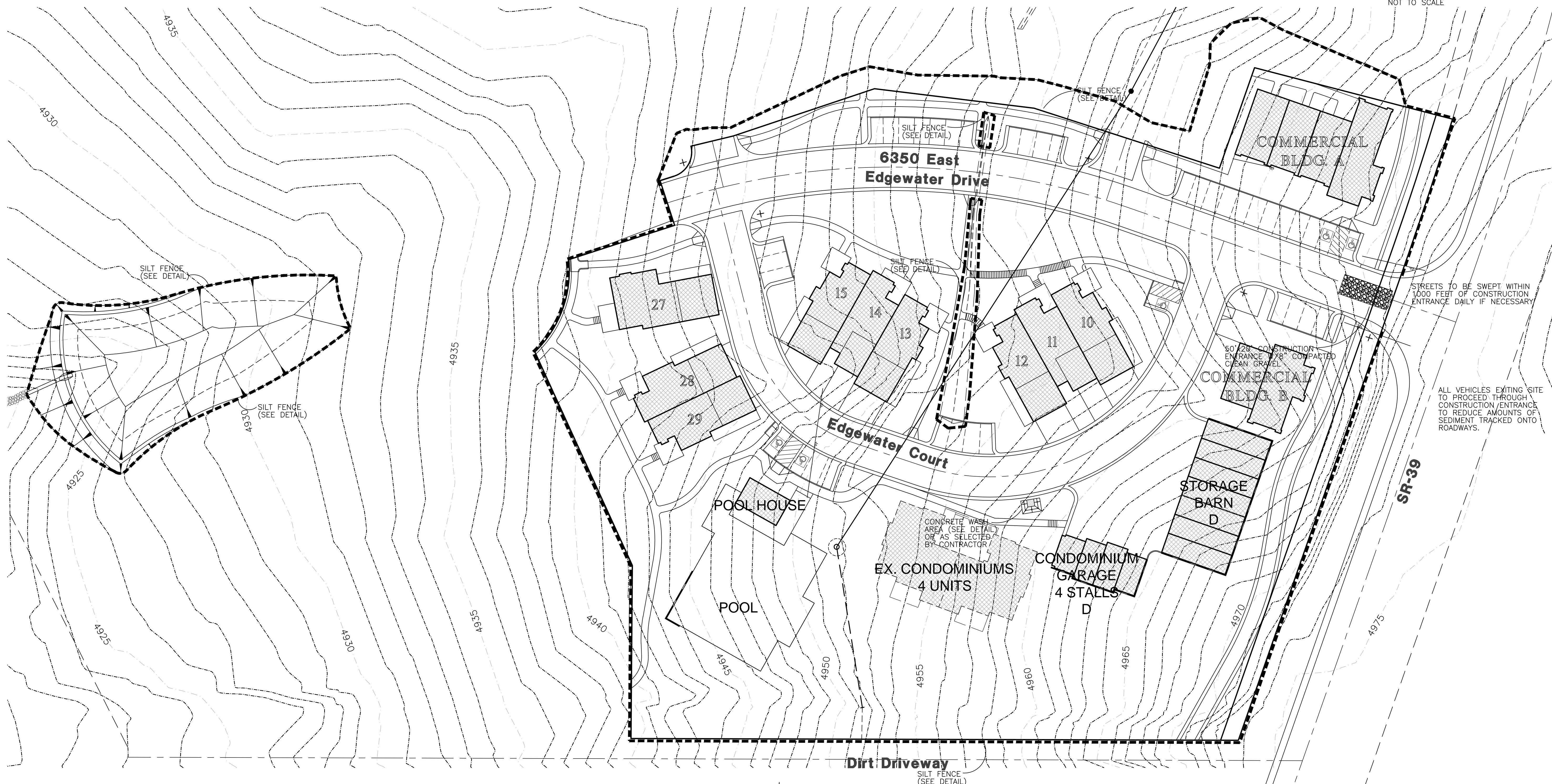

Construction Activity Schedule	
- PROJECT LOCATION	WEBER COUNTY, UTAH
- PROJECT BEGINNING DATE	AUGUST 2013
- BMP'S DEPLOYMENT DATE	AUGUST 2013
- STORM WATER MANAGEMENT CONTACT / INSPECTOR	REESE HOWELL, JR. (801) 363-6500
- SPECIFIC CONSTRUCTION SCHEDULE INCLUDING BMP CONSTRUCTION SCHEDULE TO BE INCLUDED WITH SWPPP BY OWNER/DEVELOPER	

**Reeve & Associates, Inc.**  
920 CHAMBERS STREET, SUITE #14, OGDEN, UTAH 84403  
TEL: (801) 921-2100 FAX: (801) 621-2666 www.reeve-assoc.com  
LAND PLANNERS • CIVIL ENGINEERS • LAND SURVEYORS  
TRA PROFESSIONAL ARCHITECTS

DATE	DESCRIPTION
7-31-12	RH Design Complete
8-14-13	CA Design Complete
8-21-13	RH Co. Eng. Review
7-3-13	RH Co. Eng. Review
8-16-13	RH Co. Eng. Review
9-19-13	RH Co. Eng. Review
10-21-13	RH Sewer Revisions

**Edgewater Beach Resort  
Phase-1  
Storm Water Pollution  
Prevention Plan Exhibit**  
WEBER COUNTY, UTAH

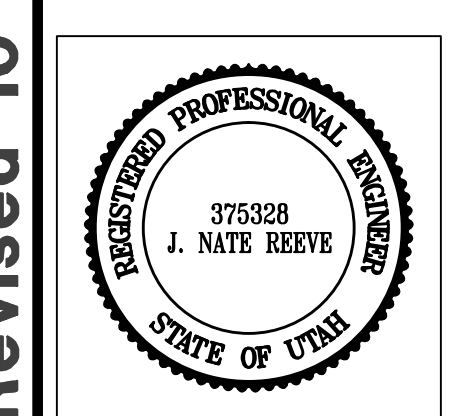

<b>Project Info.</b>	
Engineer:	J. NATE REEVE, P.E.
Drafter:	R. HANSEN
Begin Date:	JULY 09, 2012
Name:	EDGEWATER BEACH RESORT PHASE-1
Number:	5917-15

Sheet	<b>12</b>
<b>11</b>	Sheets



**Notes:**

- Describe all BMP's to protect storm water inlets:  
All storm water inlets to be protected by straw wattle barriers, or gravel bags (see detail).
- Describe BMP's to eliminate/reduce contamination of storm water from:
  - Equipment / building / concrete wash areas:  
To be performed in designated areas only and surrounded with silt fence barriers.
  - Soil contaminated by soil amendments:  
If any contaminants are found or generated, contact environmental engineer and contacts listed.
  - Areas of contaminated soil:  
If any contaminants are found or generated, contact environmental engineer and contacts listed.
  - Fueling area:  
To be performed in designated areas only and surrounded with silt fence.
  - Vehicle maintenance areas:  
To be performed in designated areas only and surrounded with silt fence.
  - Vehicle parking areas:  
To be performed in designated areas only and surrounded with silt fence.
  - Equipment storage areas:  
To be performed in designated areas only and surrounded with silt fence.
  - Materials storage areas:  
To be performed in designated areas only and surrounded with silt fence.
  - Waste containment areas:  
To be performed in designated areas only and surrounded with silt fence.
  - Service areas:  
To be performed in designated areas only and surrounded with silt fence.
- BMP's for wind erosion:  
Stockpiles and site as needed to be watered regularly to eliminate / control wind erosion
- Construction Vehicles and Equipment:
  - Maintenance
    - Maintain all construction equipment to prevent oil or other fluid leaks.
    - Keep vehicles and equipment clean, prevent excessive build-up of oil and grease.
    - Regularly inspect on-site vehicles and equipment for leaks, and repair immediately.
    - Check incoming vehicles and equipment (including delivery trucks, and employee and subcontractor vehicles) for leaking oil and fluids. Do not allow leaking vehicles or equipment on-site.
    - Segregate and recycle wastes, such as greases, used oil or oil filters, antifreeze, cleaning solutions, automotive batteries, hydraulic, and transmission fluids.
  - Fueling
    - If fueling must occur on-site, use designated areas away from drainage.
    - Locate on-site fuel storage tanks within a bermed area designed to hold the tank volume.
    - Cover retention area with an impervious material and install in a manner to ensure that any spills will be contained in the retention area. To catch spills or leaks when removing or changing fluids.
    - Use drip pans for any oil or fluid changes.
  - Washing
    - Use as little water as possible to avoid installing erosion and sediment controls for the wash area.
    - If washing must occur on-site, use designated, bermed wash areas to prevent waste water discharge into storm water, creeks, rivers, and other water bodies.
    - Use phosphate-free, biodegradable soaps.
    - Do not permit steam cleaning on-site.
- Spill Prevention and Control
  - Minor Spills:  
Minor spills are those which are likely to be controlled by on-site personnel. After contacting local emergency response agencies, the following actions should occur upon discovery of a minor spill:
    - Contain the spread of the spill.
    - If the spill occurs on paved or impermeable surfaces, clean up using "dry" methods (i.e. absorbent materials, cat litter, and / or rags).
    - If the spill occurs in dirt areas, immediately contain the spill by constructing an earth dike. Dig up properly dispose of contaminated soil.
    - If the spill occurs during rain, cover the impacted area to avoid runoff.
    - Record all steps taken to report and contain spill.
  - Major Spills:  
On-site personnel should not attempt to control major spills until the appropriate and qualified emergency response staff have arrived at the site. For spills of federal reportable quantities, also notify the National Response Center at (800) 424-8802. A written report should be sent to all notified authorities. Failure to report major spills can result in significant fines and penalties.
- Post Roadway / Utility Construction
  - Maintain good housekeeping practices.
  - Enclose or cover building material storage areas.
  - Properly store materials such as paints and solvents.
  - Store dry and wet materials under cover, away from drainage areas.
  - Avoid mixing excess amounts of fresh concrete or cement on-site.
  - Perform washout of concrete trucks offsite or in designated areas only.
  - Do not wash out concrete trucks into storm drains, open ditches, streets or streams.
  - Do not place material or debris into streams, gutters or catch basins that stop or reduce the flow of runoff water.
  - All public streets and storm drain facilities shall be maintained free of building materials, mud and debris caused by grading or construction operations. Roads will be swept within 1000' of construction entrance daily, if necessary.
  - Install straw wattle around all inlets contained within the development and all others that receive runoff from the development.
- Erosion Control Plan Notes
  - The contractor will designate an emergency contact that can be reached 24 hours a day 7 days a week.
  - A stand-by crew for emergency work shall be available at all times during potential rain or snow runoff events. Necessary materials shall be available on site and stockpiled at convenient locations to facilitate rapid construction of emergency devices when rain or runoff is eminent.
  - Erosion control devices shown on the plans and approved for the project may not be removed without approval of the engineer of record. If devices are removed, no work may continue that have the potential of erosion without consulting the engineer of record. If deemed necessary erosion control should be reestablished before this work begins.
  - Graded areas adjacent to fill slopes located at the site perimeter must drain away from the top of the slope at the conclusion of each working day. This should be confirmed by survey or other means acceptable to the engineer of record.
  - All silt and debris shall be removed from all devices within 24 hours after each rain or runoff event.
  - Except as otherwise approved by the inspector, all removable protective devices shown shall be in place at the end of each working day and through weekends until removal of the system is approved.
  - All loose soil and debris, which may create a potential hazard to offsite property, shall be removed from the site as directed by the Engineer of record of the governing agency.
  - The placement of additional devices to reduce erosion damage within the site is left to the discretion of the Engineer of record.
  - Desilting basins may not be removed or made inoperable without the approval of the engineer of record and the governing agency.
  - Erosion control devices will be modified as need as the project progresses, and plans of these changes submitted for approval by the engineer of record and the governing agency.
- Conduct a minimum of one inspection of the erosion and sediment controls every two weeks. Maintain documentation on site.
  - Part III.D.4 of general permit UTR300000 identifies the minimum inspection requirements.
  - Part III.D.4.C identifies the minimum inspection report requirements.
  - Failure to complete and/or document storm water inspections is a violation of part III.D.4 of Utah General Permit UTR 300000.

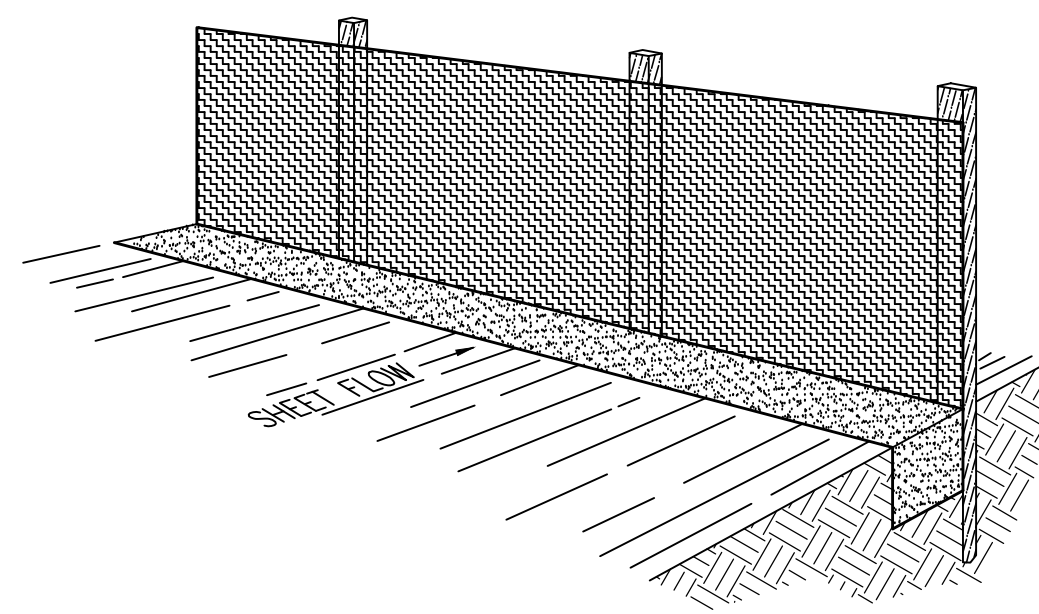

**Perspective View**

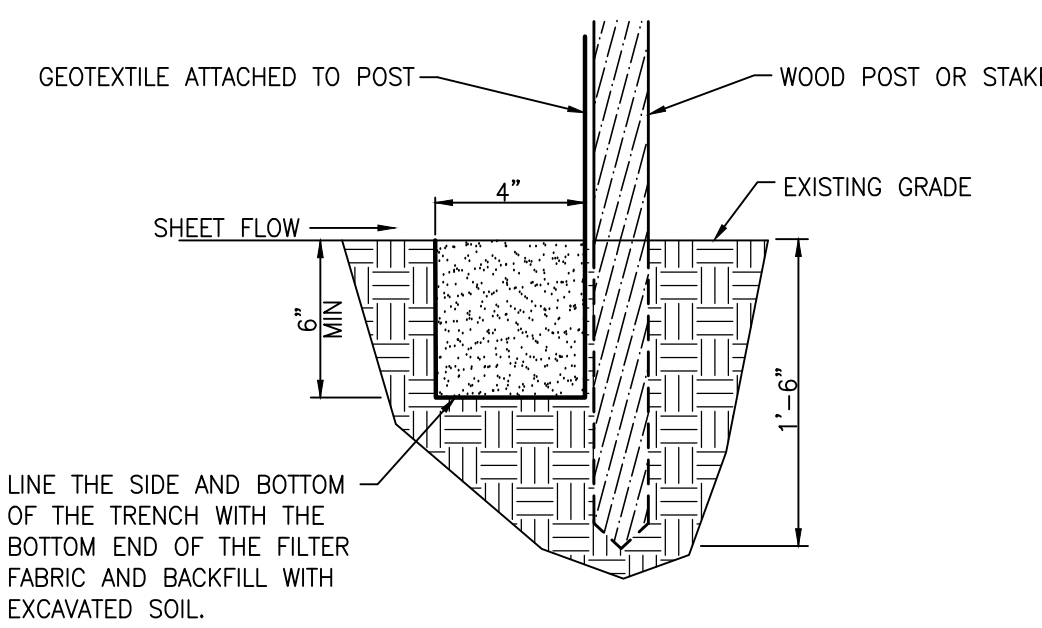

**Section**

**INSTALLATION**

The silt fence should be installed prior to major soil disturbances in the drainage area. The fence should be placed across the slope along a line of uniform elevation wherever flow of sediment is anticipated. Table 1 shows generally-recommended maximum slope lengths (slope spacing between fences) at various site grades for most silt fence applications.

TABLE 1: Recommended Maximum Slope Lengths for Silt Fence (Richardson & Middlebrooks, 1991)	
Slope Steepness (%)	Max. Slope Length m (ft)
<2%	30.5m (100ft)
2-5%	22.9m (75ft)
5-10%	15.2m (50ft)
10-20%	7.6m (25ft)
>20%	4.5m (15ft)

**PREFABRICATED SILT FENCE ROLLS**

- Excavate a minimum 15.2cm x 15.2cm (6"x6") trench at the desired location.
- Unroll the silt fence, positioning the post against the downstream wall of the trench.
- Adjacent rolls of silt fence should be joined by nesting the end post of one fence into the other. Before nesting the end posts, rotate each post until the geotextile is wrapped completely around the post, then abut the end posts to create a tight seal as shown in Figure 1.
- Drive posts into the ground until the required fence height and/or anchorage depth is obtained.
- Bury the loose geotextile at the bottom of the fence in the upstream trench and backfill with natural soil, tamping the backfill to provide good compaction and anchorage. Figure 2 illustrates a typical silt fence installation and anchor trench placement.

should generally be less than three (3) times the height of the fence.

- If a steel or plastic mesh is required to reinforce the geotextile, it shall have a minimum mesh opening of 15.2cm (6").
- Fasten the mesh to the upslope side of the posts using heavy duty wire staples, tie wires or hog strings. Extend the mesh into the bottom of the trench.
- The geotextile shall then be stapled or wired to the posts. An extra 20-50cm (8-20") of geotextile shall extend into the trench.

**INSPECTION**

- Inspect the silt fence daily during periods of rainfall, immediately after significant rainfall event and weekly during periods of no rainfall. Make any repairs immediately.
- When sediment deposits behind the silt fence are one-third of the fence height, remove and properly dispose of the silt accumulations. Avoid damage to the fabric during cleanout.

**REMOVAL**

- Silt fence should not be removed until construction ceases and the upslope area has been properly stabilized and/or revegetated.

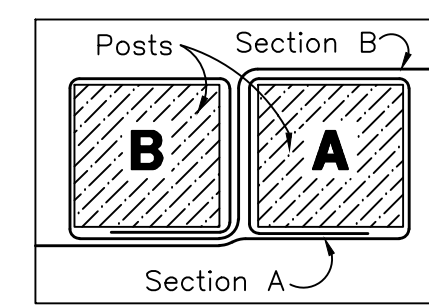
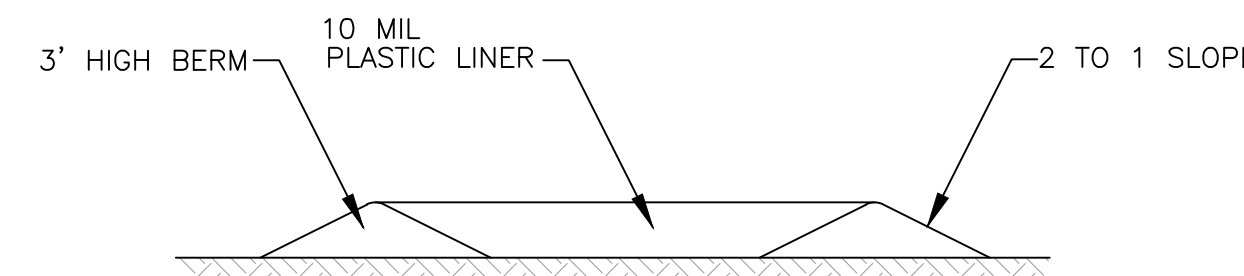
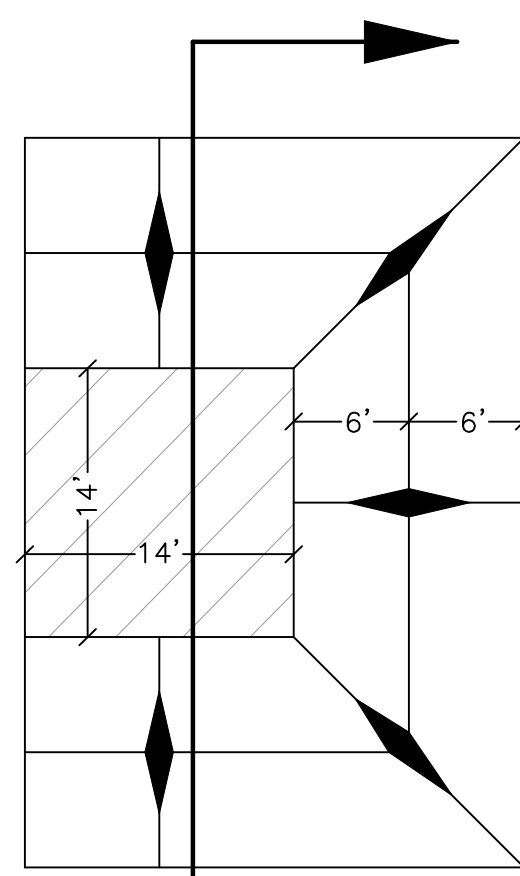

Figure 1:  
Top View of  
Roll-to-Roll Connection

**Silt Fence Detail**

SCALE: NONE



**Concrete Washout Area  
w/ 10 mil Plastic Liner**

SCALE: NONE

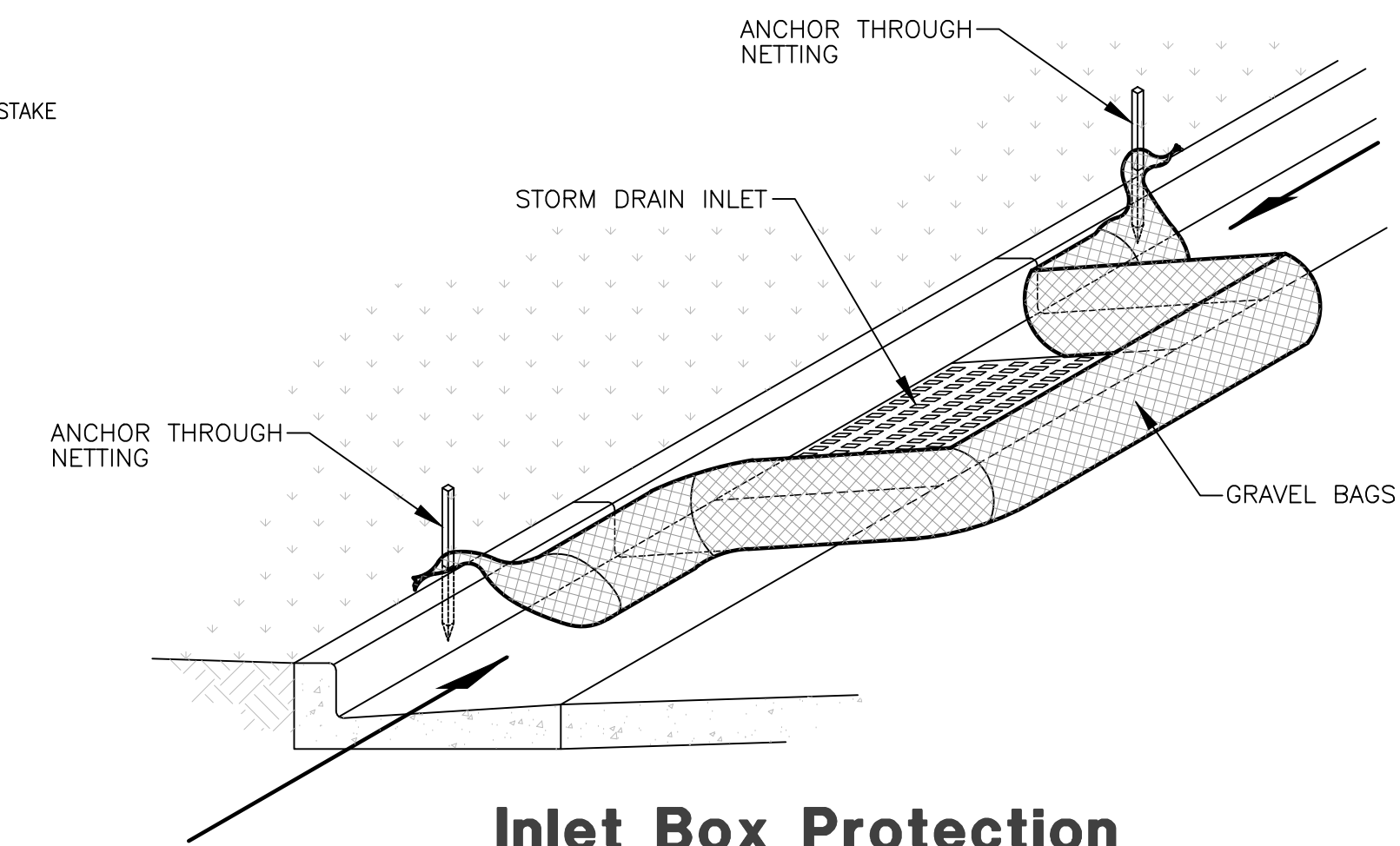

**Inlet Box Protection**

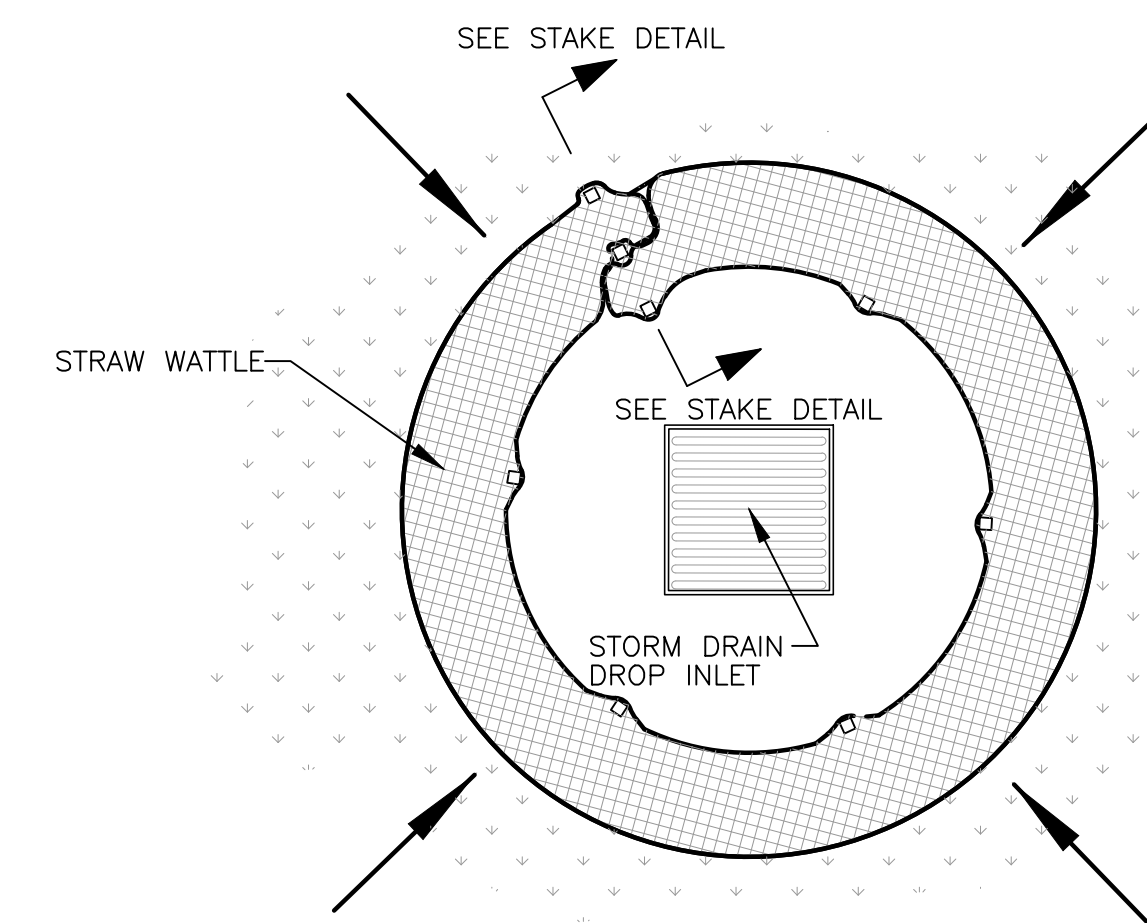

**Plan View**

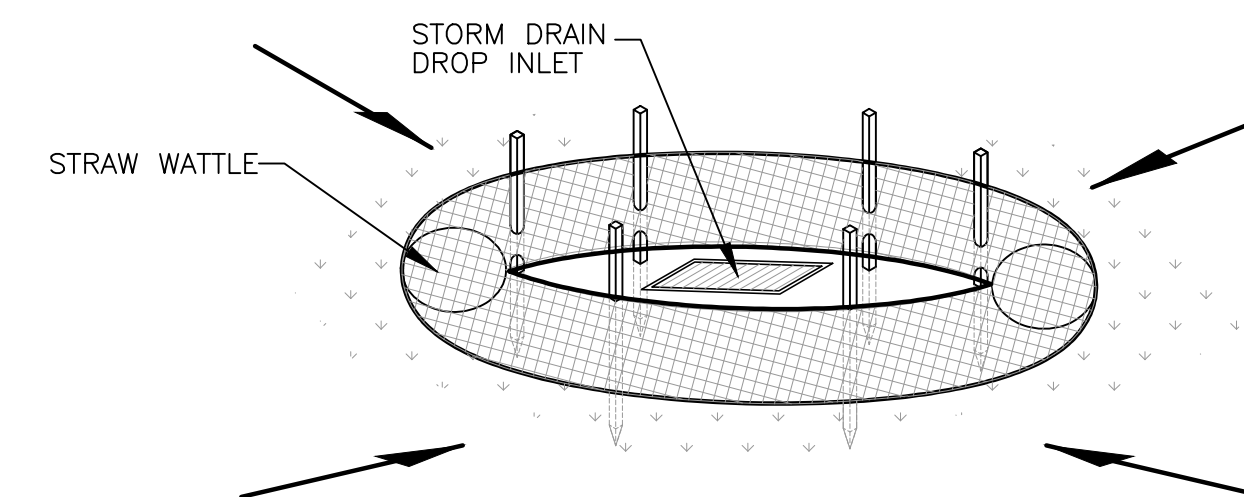

**Drop Inlet Protection**

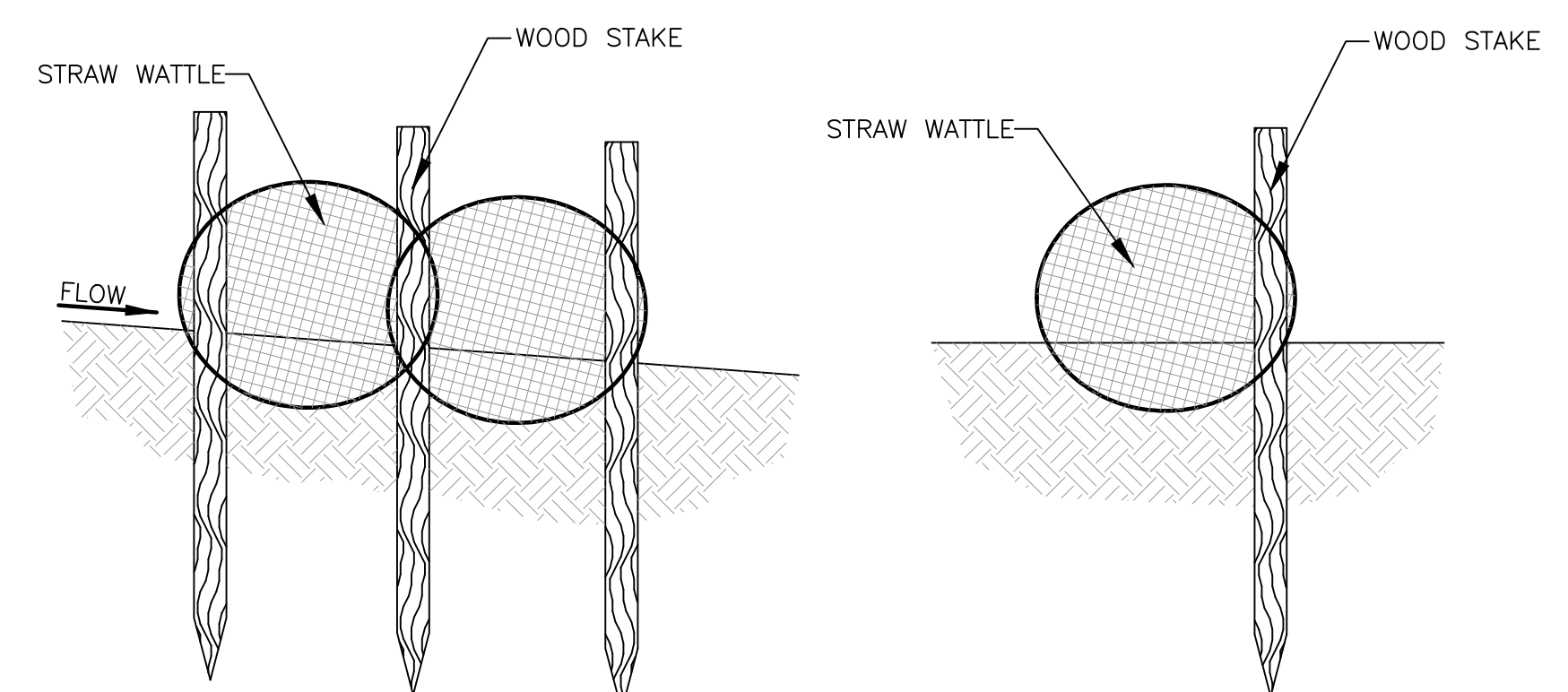

**Stake Detail**

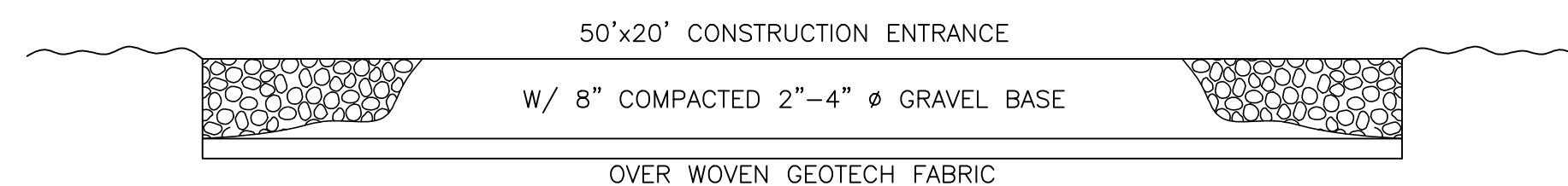

**Cross Section 50' x 20' Construction Entrance**

**Reeve & Associates, Inc.**  
**IRA**  
 920 CHAMBERS STREET, SUITE #14, OGDEN, UTAH 84403  
 TEL: (801) 621-2100 FAX: (801) 621-2666 www.reeve-assoc.com  
 LAND PLANNERS • CIVIL ENGINEERS • LAND SURVEYORS  
 PUBLIC ENGINEERS • LANDSCAPE ARCHITECTS

REVISIONS	DATE	DESCRIPTION
	7-31-12	RH Design Complete
	3-14-13	CA Design Complete
	6-21-13	RH Co. Eng. Review
	7-3-13	RH Co. Eng. Review
	8-16-13	RH Co. Eng. Review
	9-19-13	RH Co. Eng. Review
	10-21-13	RH Sewer Revisions

**Edgewater Beach Resort  
Phase-1**  
 WEBER COUNTY, UTAH  
**Storm Water Pollution  
Prevention Plan Details**

**Revised 10-21-13**

REGISTERED PROFESSIONAL ENGINEER  
 375328  
 J. NATE REEVE  
 STATE OF UTAH

**Project Info.**  
 Engineer: J. NATE REEVE, P.E.  
 Drafter: R. HANSEN  
 Begin Date: JULY 09, 2012  
 Name: EDGEWATER BEACH RESORT PHASE-1  
 Number: 5917-15

Sheet **12**  
 12 Sheets