

Salt Creek Estates Subdivision

Weber County, Utah
A Part of the Southwest Quarter of Section 36,
Township 7 North, Range 3 West, Salt Lake Base & Meridian

SURVEYOR'S CERTIFICATE

I, Clinton G. Hansen, do hereby certify that I am a Registered Professional Land Surveyor in the State of Utah in accordance with Title 58, Chapter 22, Professional Engineers and Land Surveyors Act; and I have completed a Survey of the Property Described on this Plat in accordance with Section 17-23-17 and have verified all measurements, and have placed monuments as represented on this Plat, and have hereby subdivided said tract into two (2) lots, know hereafter as Salt Creek Estates Subdivision in Weber County, Utah, and has been correctly drawn to the designated scale and is true and correct representation of the herein described lands included in said subdivision, based upon data compiled from records in the Weber County Recorder's Office and from said survey made by me on the ground, I further hereby certify that the requirements of all applicable statutes and ordinances of Weber County concerning zoning requirements regarding lot measurements have been complied with.

Signed this _____ day of _____, 20____

Clinton G. Hansen P.L.S.
Utah Land Surveyor License No. 7881387

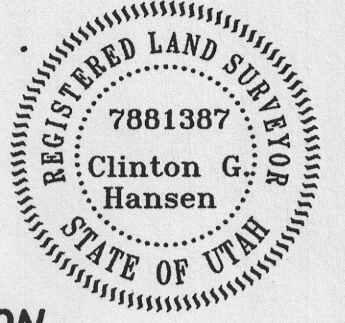

BOUNDARY DESCRIPTION

A Part of the Southwest Quarter of Section 36, Township 7 North, Range 3 West, Salt Lake Base and Meridian

Beginning at the Northwest Corner of Carver Estates Subdivision at a Point Located South 89°56'15" East 337.17 Feet Along the South Line of said Southwest Quarter and North 01°05'56" East 422.84 Feet and North 89°02'56" East 959.85 Feet from the South Corner of said Southwest Quarter and Running Thence South 00°57'04" West 237.10 Feet Along the West Line of said Carver Estates Subdivision to the North Line of the Warren Irrigation Co. Canal Property; Thence along said Warren Canal Property the following Eight (8) courses: (1) North 76°37'26" West 56.22 Feet; (2) North 79°58'09" West 613.04 Feet; (3) to the Right along the arc of a 20.50 foot radius curve a distance of 28.95 feet, having a central angle of 80°55'14", chord bears North 39°30'33" West 26.61 feet; (4) North 00°57'09" East 108.00 Feet to the south line of 1950 North Street; (5) North 89°02'56" West 79.50 Feet Along the South Line of said 1950 North Street; (6) South 00°57'04" West 108.00 Feet; (7) to the Left along the arc of a 100.00 foot radius curve a distance of 141.23 feet, having a central angle of 80°55'14", chord bears South 39°30'32" East 129.78 feet; (8) South 79°58'09" East 310.78 Feet to the West Line of Vienna Site Subdivision and its projection; Thence South 01°06'56" West 164.43 Feet Along said West Line to the South Line of said Southwest Quarter; Thence North 88°56'04" West 410.76 Feet Along the South Line of said Southwest Quarter to the East Line of 6500 West Street; Thence North 01°06'56" East 419.40 Feet Along said East Line to the South Line of 1950 North Street; Thence South 89°02'56" East 775.96 Feet Along said South Line to the Point of Beginning, Containing 4.769 Acres and Three Lots.

OWNER'S DEDICATION AND CERTIFICATION

Know all men by these presents that we, the undersigned Owners of the above described tract of land having caused the same to be subdivided into lots and streets, as shown on this plat and name said tract Salt Creek Estates Subdivision and hereby dedicate, grant and convey, in perpetuity, pursuant to the provisions of 10-9a-607, Utah code, without condition, restriction or reservation to Weber County, Utah, all those parts or portions of said tract of land designated as streets the same to be used as public thoroughfares forever, and also dedicate to Weber County those certain strips as easements for public utility and drainage purposes as shown hereon. The same to be used for the installation, maintenance and operation of public utility service lines and drainage as may be authorized by Weber County in witness we have here unto set our signature this _____ day of _____, 2012.

Gary Hales _____ Carolyn T. Hales _____

ACKNOWLEDGMENT

State of Utah
County of Weber

On this _____ day of _____, 2012, Gary Hales and Carolyn T. Hales, Husband and Wife as Joint Tenants, Personally Appeared before me, the Undersigned Notary Public in and for said County of Box Elder, in the State of Utah, the Signers of the Attached Owners Dedication, two in Numbers, who duly Acknowledged to me they Signed it Freely and Voluntarily and for the Purpose Therein Mentioned.

Notary Public

12-3-69 V12.DWG 12-3-69 CGH 5/24/12

WEBER COUNTY RECORDER

ENTRY NO. _____ FEE PAID _____
FILED FOR RECORD AND

RECORDED _____
IN BOOK _____ OF OFFICIAL

RECORDS, PAGE _____ RECORDED
FOR _____

COUNTY RECORDER

BY: _____ DEPUTY

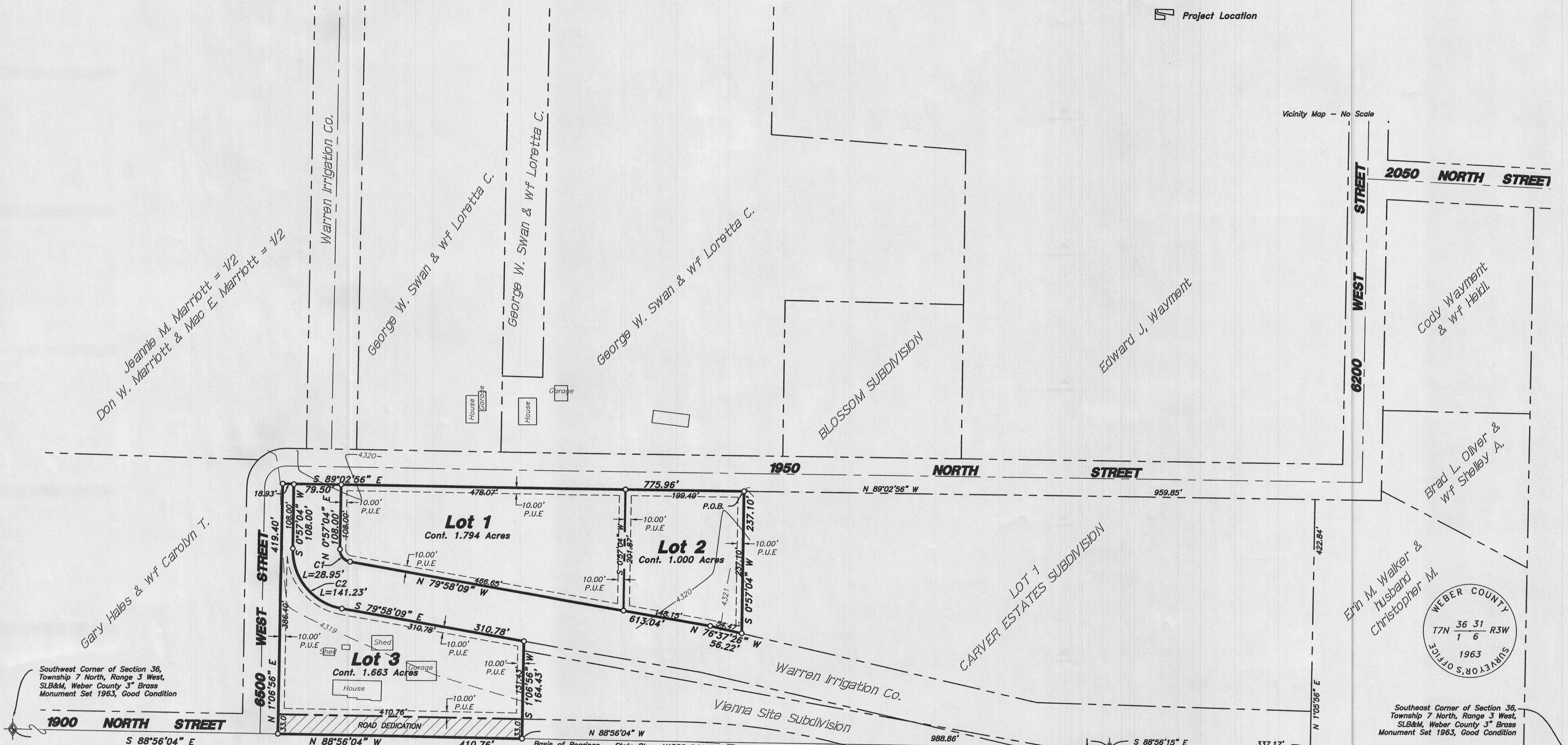

<p>WEBER COUNTY SURVEYOR'S OFFICE 36 31 R3W 1 6 1963</p>	<p>C1 Δ = 80°55'14" R = 20.50' L = 28.95' T = 17.48' LC = N 39°30'33" W 26.61'</p>	<p>C2 Δ = 80°55'14" R = 100.00' L = 141.23' T = 85.29' LC = S 39°30'32" E 129.78'</p>
--	--	---

NARRATIVE

The Purpose of this Survey was to Establish and set the Property Corners of the Two Lot Subdivision as Shown and Described Hereon. This Survey was Ordered by Jeff Hales. The Control used to Establish the Property Corners was the Existing Weber County Surveyor Monumentation Surrounding Section 36, Township 7 North, Range 3 West, S.L.B.&M. The basis of bearing is the South line of the Southwest Quarter of said Section which bears North 88°56'04" West, Utah North, State Plane, Calculated N.A.D.83 Bearing.

Developer:
Jeff Hales
5262 West 2150 North
Plain City, Utah 84404
(801) 540-9947

HANSEN & ASSOCIATES, INC.
Consulting Engineers and Land Surveyors
538 North Main Street, Brigham, Utah 84302
Visit us at www.hales.net
Brigham City Ogdan Logan
(435) 723-3491 (801) 399-4905 (435) 752-8272

WEBER COUNTY PLANNING COMMISSION APPROVAL

This is to Certify that this Subdivision Plat was Duly Approved by the Weber County Planning Commission. Signed this _____ Day of _____, 2012

Chairman, Weber County Planning Commission

WEBER COUNTY ENGINEER

I hereby Certify that the Required Public Improvement Standards and Drawings for this Subdivision Conform with the County Standards and the Amount of the Financial Guarantee is Sufficient for the Installation of these Improvements. Signed this _____ Day of _____, 2012

Weber County Engineer

WEBER COUNTY COMMISSION ACCEPTANCE

This is to Certify that this Subdivision Plat, the Dedication of Streets and other Public Ways and Financial Guarantee of Public Improvements Associated with this Subdivision, Thereon are Hereby Approved and Accepted by the Commissioners of Weber County Utah Signed this _____ Day of _____, 2012

Chairman, Weber County Commission

Attest

WEBER COUNTY SURVEYOR

I hereby Certify that the Weber County Surveyor's Office has Reviewed this Plat for Mathematical Correctness, Section Corner Data, and for Harmony with the Lines and Monuments on Record in County Offices. The Approval of this Plat by the Weber County Surveyor does not Relieve the Licensed Land Surveyor who Executed this Plat from the Responsibilities and/or Liabilities Associated Therewith. Signed this _____ Day of _____, 2012

Weber County Surveyor

WEBER COUNTY ATTORNEY

I have Examined the Financial Guarantee and Other Documents Associated with this Subdivision Plat, and in my Opinion they Conform with the County Ordinance Applicable Thereon and now in Force and Effect Signed this _____ Day of _____, 2012

Weber County Attorney

WEBER-MORGAN HEALTH DEPARTMENT

I hereby Certify that the Soils, Percolation Rates, and Site Conditions for this Subdivision have been Investigated by this Office and are Approved for On-Site Wastewater Disposal Systems. Signed this _____ Day of _____, 2012

Weber-Morgan Health Department

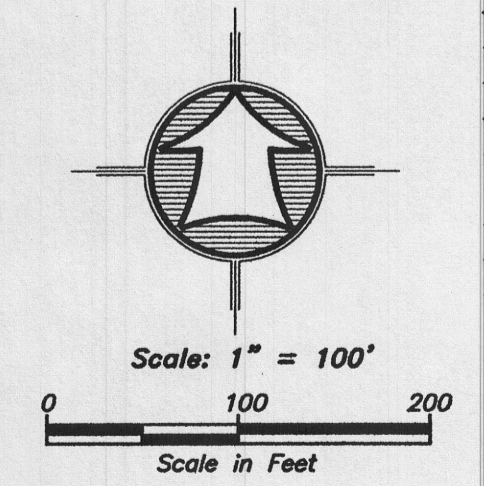

LEGEND

	Subdivision Boundary Line
	Lot Line
	Adjoining property Line
	Public Utility Easement (P.U.E.)
	Easement
	Fence Line
	Existing Storm Drain
	Existing Ditch Flowline
	Existing Edge of Gravel
	Existing Sewer Line
	Existing Water Line
	Section Corner
	Found Survey Point
	Set 5/8" Rebar With Cap