

FOUND
NORTH QUARTER CORNER
SEC. 20, T7N, R1E, SLB&M
WC BRASS CAP

FOUND
NORTHEAST CORNER SEC. 20,
NORTHWEST CORNER SEC. 21,
T7N, R1E, SLB&M
WC BRASS CAP

N89°39'58"W 2678.61' (BASIS OF BEARING)
453.67'

**RECORD PARCEL 220100021
BOUNDARY DESCRIPTION**

PART OF THE NORTHEAST QUARTER OF SECTION 20, TOWNSHIP 7 NORTH, RANGE 1 EAST, SALT LAKE MERIDIAN, U.S. SURVEY; BEGINNING AT A POINT NORTH 89D56' WEST 579.75 FEET AND SOUTH 7D16' EAST 995.19 FEET FROM THE NORTHEAST CORNER OF SAID SECTION 20; RUNNING THENCE SOUTH 7D16' EAST 150.00 FEET; THENCE SOUTH 89D53' EAST 221.82 FEET, MORE OR LESS; THENCE NORTH 4D02' WEST 60 FEET; THENCE SOUTH 89D53' EAST 70 FEET, MORE OR LESS; THENCE NORTH 7D16' WEST 85 FEET, MORE OR LESS; THENCE NORTH 89D53' WEST 292.82 FEET TO BEGINNING.

**RECORD PARCEL 220100023
BOUNDARY DESCRIPTION**

PART OF THE NORTHEAST QUARTER OF SECTION 20, AND PART OF THE NORTHWEST QUARTER OF SECTION 21, TOWNSHIP 7 NORTH, RANGE 1 EAST, BEGINNING AT A POINT NORTH 89D56' WEST 579.75 FEET AND SOUTH 7D16' EAST 1145.19 FEET AND SOUTH 89D53' EAST 221.82 FEET, MORE OR LESS, AND NORTH 4D02' WEST 60 FEET; AND SOUTH 89D53' EAST 70 FEET, MORE OR LESS, FROM THE NORTHEAST CORNER OF SAID SECTION 20; RUNNING THENCE NORTH 7D16' WEST 85 FEET, MORE OR LESS, THENCE NORTH 89D53' WEST 292.82 FEET; THEN E NORTH 7D16' WEST 68 FEET; THENCE SOUTH 89D53' EAST 290.4 FEET; THENCE NORTH 7D16' WEST 150 FEET; THENCE SOUTH 89D53' EAST 558.30 FEET; THENCE SOUTH 13D36' EAST 110.51 FEET; THENCE SOUTH 6D22' WEST 122.13 FEET; THENCE SOUTH 89D53' WEST 340.00 FEET; THENCE SOUTH 0D07' WEST 71.00 FEET, THENCE NORTH 89D53' WEST 190.00 FEET TO THE POINT OF BEGINNING.

**COMBINED MCFARLAND PROPERTY
BOUNDARY DESCRIPTION**

A PART OF THE NORTHEAST QUARTER OF SECTION 20, AND THE NORTHWEST QUARTER OF SECTION 21, TOWNSHIP 7 NORTH, RANGE 1 EAST OF THE SALT LAKE BASE AND MERIDIAN, MORE PARTICULARLY DESCRIBED AS FOLLOWS:
BEGINNING AT A POINT ON AN EXISTING FENCE LINE, SAID POINT ALSO BEING ON THE EASTERLY RIGHT-OF-WAY LINE OF 3800 EAST STREET BEING LOCATED NORTH 89°39'58" WEST 453.67 FEET ALONG THE NORTH LINE OF SAID NORTHEAST QUARTER OF SAID SECTION 20, AND SOUTH 0°00'00" EAST 923.27 FEET FROM THE NORTHEAST CORNER OF SAID SECTION 20; RUNNING THENCE ALONG SAID EXISTING FENCE LINE THE FOLLOWING (2) TWO COURSES: (1) NORTH 86°17'04" EAST 310.01 FEET; (2) NORTH 8°54'58" WEST 133.82 FEET; THENCE SOUTH 89°39'58" EAST 556.35 FEET TO THE WESTERLY LINE OF THE STONE CREEK ESTATES SUBDIVISION; THENCE ALONG SAID WESTERLY LINE THE FOLLOWING (3) THREE COURSES: (1) SOUTH 7°37'13" EAST 111.29 FEET; (2) SOUTH 8°05'11" EAST 142.10 FEET; (3) SOUTH 22°18'43" WEST 14.13 FEET; THENCE SOUTH 89°38'51" WEST 371.81 FEET; THENCE SOUTH 0°21'05" EAST 37.86 FEET TO A SURVEYED LINE RECORDED ON APRIL 25, 2006 AS SURVEY NO. 3608; THENCE ALONG SAID SURVEYED LINE THE FOLLOWING (3) THREE COURSES: (1) SOUTH 89°45'33" WEST 256.23 FEET; (2) SOUTH 4°30'40" EAST 60.17 FEET; (3) SOUTH 89°56'31" WEST 221.91 FEET TO THE EASTERLY RIGHT-OF-WAY LINE OF SAID 3800 EAST STREET; THENCE ALONG SAID LINE NORTH 7°44'40" WEST 218.18 FEET TO THE POINT OF BEGINNING, CONTAINING 219,838 SQ. FT. OR 5.05 AC, MORE OR LESS.



COMBINED PARCELS
CONTAINING:
219,838 SQ.FT.
OR 5.05 ACRES

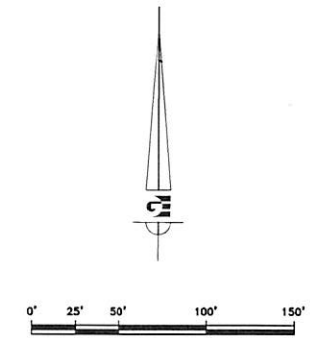

- LEGEND**
- WEBER COUNTY MONUMENT AS NOTED
 - SET 24" REBAR AND CAP MARKED GARDNER ENGINEERING
 - PROPERTY LINE
 - ADJACENT PARCEL
 - SECTION LINE
 - EXISTING FENCE
 - ORIGINAL DEED LINE
 - EXISTING RIGHT-OF-WAY LINE

SURVEYOR'S CERTIFICATE

I, KLINT H. WHITNEY, DO HEREBY CERTIFY THAT I AM A LICENSED PROFESSIONAL LAND SURVEYOR IN THE STATE OF UTAH AND THAT I HOLD CERTIFICATE NO. 8227228 IN ACCORDANCE WITH TITLE 69, CHAPTER 22, OF THE PROFESSIONAL ENGINEERS AND LAND SURVEYORS ACT; I FURTHER CERTIFY THAT BY AUTHORITY OF THE OWNERS I HAVE COMPLETED A SURVEY OF THE PROPERTY DESCRIBED ON THIS RECORD OF SURVEY PLAT IN ACCORDANCE WITH SECTION 17-23-20 AND HAVE VERIFIED ALL MEASUREMENTS; THAT THE REFERENCE MONUMENTS SHOWN ON THIS RECORD OF SURVEY PLAT ARE LOCATED AS INDICATED AND ARE SUFFICIENT TO RETRACE OR REESTABLISH THIS SURVEY; AND THAT THE INFORMATION SHOWN HEREIN IS SUFFICIENT TO ACCURATELY ESTABLISH THE LATERAL BOUNDARIES OF THE HEREIN DESCRIBED TRACT OF REAL PROPERTY.

SIGNED THIS _____ DAY OF _____, 2018.



NARRATIVE:

THE PURPOSE OF THE SURVEY WAS TO DETERMINE AND COMBINE THE BOUNDARIES OF PARCELS NO. 220100023 AND NO. 220100021 AS SHOWN AND DESCRIBED HEREON. THE SURVEY WAS ORDERED BY BRET MCFARLAND. THE CONTROL USED TO ESTABLISH THE BOUNDARY WAS THE EXISTING WEBER COUNTY SURVEY MONUMENTATION AS SHOWN AND NOTED HEREON. THE EASTERLY PROPERTY LINE WERE ESTABLISHED BY HONORING THE STONE CREEK ESTATES SUBDIVISION. THE RIGHT-OF-WAY LINE OF 3800 EAST STREET WAS ESTABLISHED BY HONORING THE PROJECTED RIGHT-OF-WAY LINE AS SHOWN ON RECORD OF SURVEY NO. 3608. THE BASIS OF BEARING IS THE NORTH LINE OF THE NORTHEAST QUARTER OF SECTION 20, TOWNSHIP 7 NORTH, RANGE 1 EAST, OF THE SALT LAKE BASE AND MERIDIAN WHICH BEARS NORTH 89°39'58" WEST WEBER COUNTY, UTAH NORTH, NAD 83 STATE PLANE GRID BEARING.

FOUND
EAST QUARTER CORNER SEC. 21,
T7N, R1E, SLB&M
WC BRASS CAP

SCALE: 1"=50'	DATE: 12/20/18	DESIGN: _____	DRAWN: SGP	CHECKED: KHW
REVISIONS	DESCRIPTION			
DATE				

PROPERTY SURVEY/PARCEL COMBINATION FOR
MCFARLAND FAMILY 3800 NORTH 3900 EAST, LIBERTY, UTAH
LOCATED IN THE NORTHEAST QUARTER OF SECTION 20, AND
THE NORTHWEST QUARTER OF SEC. 21, T7N, R1E, S.L.B.&M.

GARDNER ENGINEERING
CIVIL - LAND PLANNING
MUNICIPAL - LAND SURVEYING
5150 SOUTH 411 375 EAST OGDEN, UT
OFFICE: 801.476.0202 FAX: 801.476.0066

S1
1