

Bailey's Back Five First Amendment Amending Lot 1

Weber County, Utah
A Part of the Northwest Quarter of Section 17,
Township 6 North, Range 2 East, Salt Lake Base & Meridian
February 2019

SURVEYOR'S CERTIFICATE

I, K. Greg Hansen, do hereby certify that I am a Registered Professional Land Surveyor in the State of Utah in accordance with Title 58, Chapter 22, Professional Engineers and Professional Land Surveyors Act; and I have completed a Survey of the property described on this plat in accordance with Section 17-23-17 and have verified all measurements, and have placed monuments as represented on this plat, and have hereby Amended and Subdivided said tract into one (1) lot, known hereafter as Bailey's Back Five First Amendment in Weber County, Utah, and has been correctly drawn to the designated scale and is true and correct representation of the herein described lands included in said Subdivision, based upon data compiled from records in the Weber County Recorder's Office and from said survey made by me or under my supervision on the ground, I further hereby certify that the requirements of all applicable statutes and ordinances of Weber County concerning Zoning Requirements regarding lot measurements have been complied with.

Signed this _____ day of _____, 2019.

K. Greg Hansen P.L.S.
Utah Land Surveyor License No. 167819



SUBDIVISION BOUNDARY DESCRIPTION

A PART OF THE NORTHWEST QUARTER OF SECTION 17, TOWNSHIP 6 NORTH, RANGE 2 EAST OF THE SALT LAKE BASE AND MERIDIAN.

BEGINNING AT THE NORTHWEST CORNER OF LOT 1, BAILEY'S BACK FIVE RECORDED AS ENTRY NO. 1970319 IN THE WEBER COUNTY RECORDERS OFFICE LOCATED 781.03 FEET SOUTH 00°22'13" WEST ALONG THE WEST LINE OF SAID SECTION AND 901.48 FEET SOUTH 88°43'35" EAST FROM THE NORTHWEST CORNER OF SAID SECTION 17;

RUNNING THENCE ALONG THE BOUNDARY OF SAID BAILEY'S BACK FIVE THE FOLLOWING SEVEN (7) COURSES: (1) SOUTH 88°43'35" EAST 20.00 FEET; (2) SOUTH 00°28'26" WEST 635.44 FEET; (3) SOUTH 00°34'46" EAST 111.25 FEET; (4) SOUTH 89°40'18" EAST 130.02 FEET; (5) SOUTH 00°34'46" EAST 443.87 FEET; (6) NORTH 89°37'52" EAST 193.04 FEET; AND (7) SOUTH 00°17'28" EAST 440.86 FEET TO THE SOUTHEAST CORNER OF SAID BAILEY'S BACK FIVE; THENCE NORTH 88°52'28" WEST 116.19 FEET ALONG THE SOUTH LINE OF SAID BAILEY'S BACK FIVE; THENCE SOUTH 00°12'01" WEST 388.31 FEET; THENCE NORTH 88°40'17" WEST 219.71 FEET TO THE SOUTHERLY PROJECTION OF THE WEST LINE OF SAID BAILEY'S BACK FIVE; THENCE NORTH 00°34'46" WEST 1372.18 FEET ALONG SAID SOUTHERLY PROJECTION AND THEN ALONG SAID WEST LINE TO AN ANGLE POINT; THENCE NORTH 00°28'25" EAST 636.09 FEET ALONG SAID WEST LINE TO THE POINT OF BEGINNING. CONTAINING 7.254 ACRES.

SUBJECT TO A 20.00 FOOT WIDE ACCESS EASEMENT AS DESCRIBED IN ENTRY NO. 1890830.

OWNER'S DEDICATION

Know all men by these presents that we, the undersigned owners of the above described tract of land having caused the same to be amended and subdivided into a lot as shown on this plat and name said tract Bailey's Back Five First Amendment and hereby dedicate, grant and convey to Weber County, Utah, all those parts or portions of said tract of land designated as easements for public utility and drainage purposes as shown hereon. The same to be used for the installation, maintenance and operation of public utility service lines and drainage as may be authorized by Weber County.

This _____ day of _____, 2019.

Lonny Bailey Nancy Bailey

Sheryll Land Vanderhooff, Member of
ESPL Investments, LLC, Partner to ESPL Investments Limited Partnership

ACKNOWLEDGMENT

State of Utah
County of _____

On this _____ day of _____, 2019, Lonny Bailey and Nancy Bailey, Husband and Wife as Joint Tenants, personally appeared before me, the undersigned Notary Public in and for said County of _____, in the State of Utah, the signers of the attached Owners Dedication, two in numbers, who duly acknowledged to me they signed it freely and voluntarily and for the purpose therein mentioned.

Notary Public

CORPORATE ACKNOWLEDGMENT

State of Utah
County of Weber

On the _____ day of _____, 2019, Sheryll Land Vanderhooff personally appeared before me, the undersigned notary public in and for said state and county, being duly sworn, acknowledged to me that she is the member of ESPL Investments, LLC, Partner to ESPL Investments Limited Partnership and that she signed the above owner's dedication, who duly acknowledged to me that she signed it freely and voluntarily and for the uses and purposes therein mentioned.

Notary public

WEBER COUNTY RECORDER

ENTRY NO. _____ FEE PAID _____
FILED FOR RECORD AND

RECORDED _____
IN BOOK _____ OF OFFICIAL

RECORDS, PAGE _____ RECORDED FOR _____

COUNTY RECORDER

BY: _____
DEPUTY

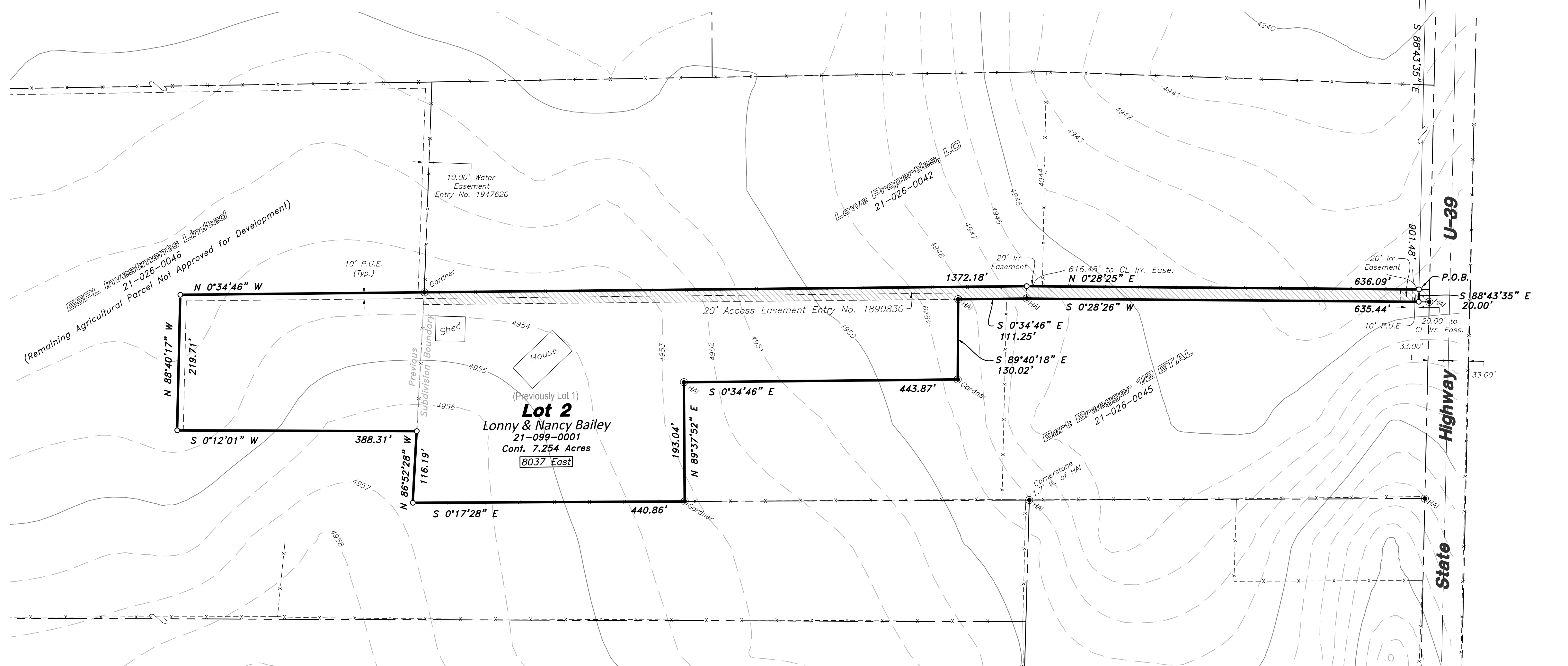

NOTE:
1 - All public utility easements (P.U.E.) are 10.0 foot wide unless otherwise noted.
2 - Rebar and cap set on all lot corners as shown hereon.

Developer:
Sheryll Vanderhooff
2844 S. Chadwick St.
SLC, UT 84106
(801) 272-6276

- LEGEND**
- Subject Property Line
 - Adjoining Property Line
 - Previous Property Line
 - Centerline
 - Public Utility Easement (PUE)
 - Existing 5.0' Contour
 - Existing 1.0' Contour
 - Fence Line (Wire)
 - Access Easement
 - Street Monument
 - Found rebar set by others
 - Set 5/8"x24" Rebar With Cap
 - Section Corner

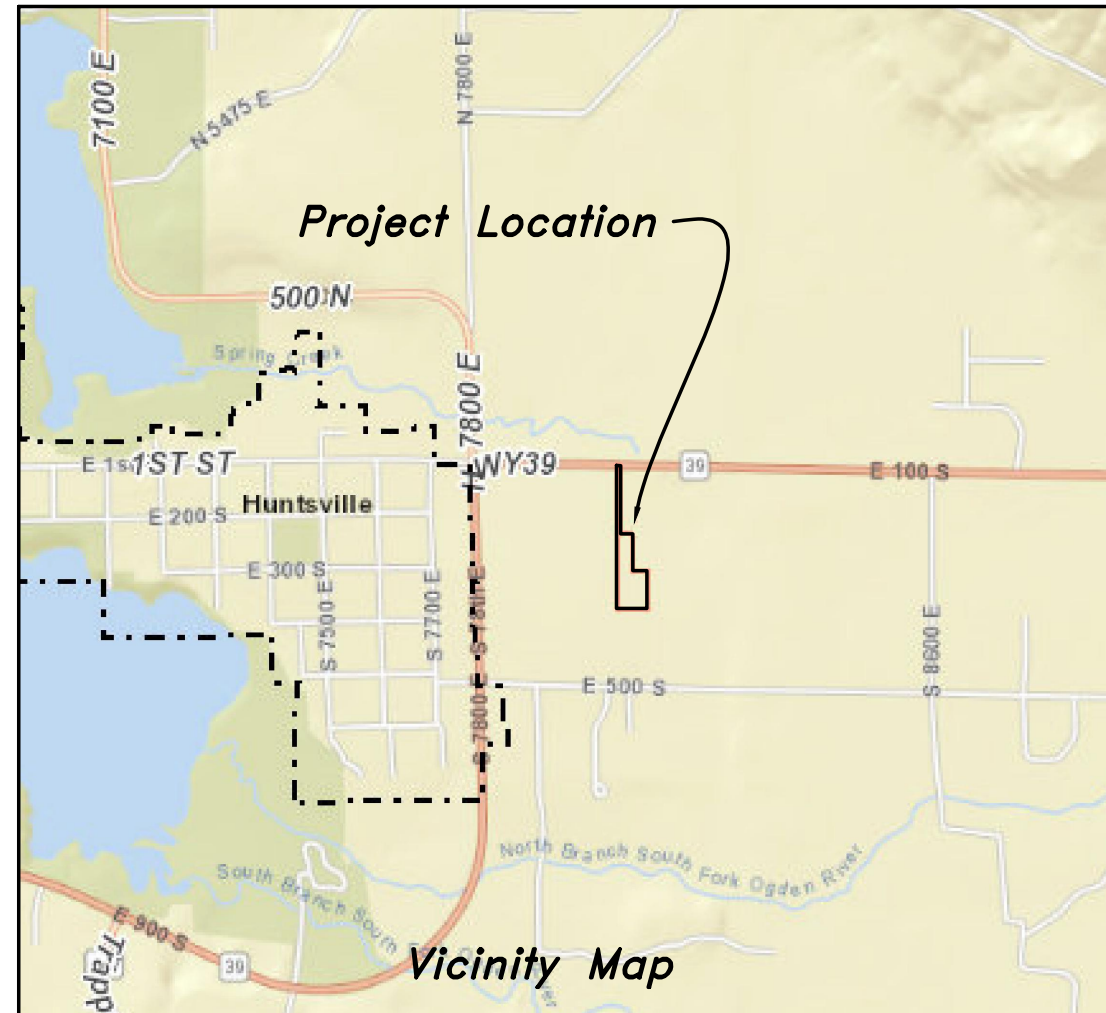
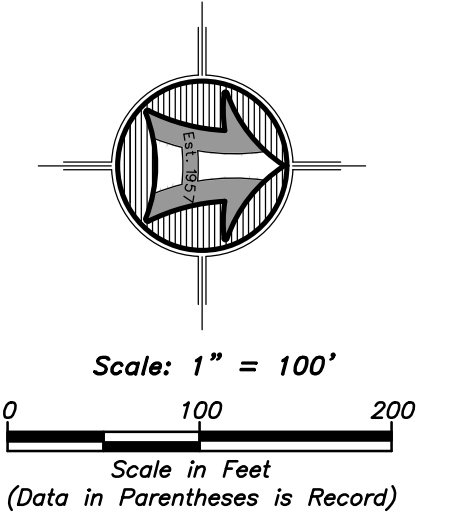

WEBER COUNTY PLANNING COMMISSION APPROVAL

This is to Certify that this Subdivision Plat was Duly Approved by the Weber County Planning Commission.
Signed this _____ Day of _____, 2019.

Chairman, Weber County Planning Commission

WEBER COUNTY ENGINEER

I Hereby Certify that the Required Public Improvement Standards and Drawings for this Subdivision Conform with the County Standards and the Amount of the Financial Guarantee is Sufficient for the Installation of these Improvements.
Signed this _____ Day of _____, 2019.

Weber County Engineer

WEBER COUNTY SURVEYOR

I Hereby Certify that the Weber County Surveyor's Office has Reviewed this Plat and all conditions for approval by this office have been satisfied. The approval of this Plat by the Weber County Surveyor does not relieve the Licensed Land Surveyor who executed this plat from the responsibilities and/or liabilities associated therewith.
Signed this _____ Day of _____, 2019.

Weber County Surveyor

WEBER COUNTY COMMISSION ACCEPTANCE

This is to Certify that this Subdivision Plat, the Dedication of Streets and other Public Ways and Financial Guarantee of Public Improvements Associated with this Subdivision, Thereon are Hereby Approved and Accepted by the Commissioners of Weber County Utah
Signed this _____ Day of _____, 2019.

Chairman, Weber County Commission

AGRICULTURAL NOTE

Agriculture is the preferred use in the Agriculture Zones. Agriculture operations as specified in the zoning ordinance for a particular zone are permitted at any time including the operation of farm machinery and no allowed agriculture use shall be subject to restriction on that it interferes with activities of future residents of this subdivision

NARRATIVE

The purpose of this survey was to amend the boundary of the One Lot Subdivision as shown and described hereon. This survey was ordered by Sheryll Vanderhooff. The control used to establish the property corners was the official plat of Bailey's Back Five recorded as Entry No. 1970319 in the Weber County Recorder's Office along with existing Weber County Surveyor Monumentation surrounding Section 17, Township 6 North, Range 2 East, S.L.B.&M. The basis of bearing is the West line of said Section which bears South 0°22'13" West, Utah North, State Plane, Calculated N.A.D.83 Bearing.

WEBER COUNTY ATTORNEY

I Have Examined the Financial Guarantee and Other Documents Associated with this Subdivision Plat, and in my Opinion they Conform with the County Ordinance Applicable Thereto and now in Force and Affect
Signed this _____ Day of _____, 2019.

Weber County Attorney

WEBER-MORGAN HEALTH DEPARTMENT

I Hereby Certify that the Soils, Percolation Rates, and Site Conditions for this Subdivision have been Investigated by this Office and are Approved for On-Site Wastewater Disposal Systems.
Signed this _____ Day of _____, 2019.

Weber-Morgan Health Department