

## Notes:

1. Describe all BMP's to protect storm water inlets. All storm water inlets to be protected by straw wattle barriers, or gravel bags (see detail).
2. Describe BMP's to eliminate/reduce contamination of storm water from:
  - a. Equipment building/concrete wash areas.
  - b. Equipment stored on-site only and surrounded with silt fence barriers.
  - c. Soil contaminated by soil amendments.
  - d. Areas of contaminated soil.
  - e. Areas of contaminated soil: If any contaminated areas are found or generated, contact environmental engineer and contacts listed.
  - f. Fueling area: To be performed in designated areas only and surrounded with silt fence.
  - g. Vehicle maintenance areas: To be performed in designated areas only and surrounded with silt fence.
  - h. Vehicle repair areas: To be performed in designated areas only and surrounded with silt fence.
  - i. Equipment storage areas: To be performed in designated areas only and surrounded with silt fence.
  - j. Materials storage areas: To be performed in designated areas only and surrounded with silt fence.
  - k. Waste containment areas: To be performed in designated areas only and surrounded with silt fence.
  - l. Service areas: To be performed in designated areas only and surrounded with silt fence.
3. BMP's for wind erosion: Stockpiles and site as needed to be watered regularly to eliminate / control wind erosion
4. Construction Vehicles and Equipment:
  - a. Maintenance
    - Maintain all construction equipment to prevent oil or other fluid leaks.
    - Keep vehicles and equipment clean, prevent excessive build-up of oil and grease.
    - Regularly inspect on-site vehicles and equipment for leaks, and repair immediately.
    - Check incoming vehicles and equipment (including delivery trucks, and employee and subcontractor vehicles)
    - Wash all equipment and vehicles before entering site. Washers should be equipped with silt fence barriers and recycle wash water.
    - Segregate and recycle wastes, such as greases, used oil or oil filters, antifreeze, cleaning solutions, automotive batteries, hydraulic and transmission fluids.
  - b. Fueling
    - Fueling must occur on-site, use designated areas away from drainage.
    - Locate on-site fuel storage tanks within a bermed area designed to hold the tank volume.
    - Cover retention area with an impervious material and install in a manner to ensure that any spills will be contained in the retention area. To catch spills or leaks when removing or changing fluids.
    - Use drip pans for any oil or fluid changes.
  - c. Washing
    - Use as little water as possible to avoid instilling erosion and sediment controls for the wash area.
    - If washing must occur on-site, use designated, bermed wash areas to prevent waste water discharge into storm water, creeks, rivers, and other water bodies.
    - Use phosphate-free, biodegradable soaps.
    - Do not permit steam cleaning on-site.
5. Spill Prevention and Control
  - a. Minor Spills: are those which are likely to be controlled by on-site personnel. After contacting local emergency response agencies, the following actions should occur upon discovery of a minor spill:
    - Contain the spread of the spill.
    - If the spill occurs on paved or impermeable surfaces, clean up using "dry" methods (i.e. absorbent materials, cat litter, and / or rags).
    - If the spill occurs in dirt areas, immediately contain the spill by constructing an earth dike. Dig up properly dispose of contaminated soil.
    - If the spill occurs during rain, cover the impacted area to avoid runoff.
  - b. Major Spills: On-site personnel should not attempt to control major spills until the appropriate and qualified emergency response contractor is notified. On-site personnel should report the spill to the National Response Center (800) 424-9802. A spill response plan should be sent to all notified authorities. Failure to report major spills can result in significant fines and penalties.
6. Post Roadway / Utility Construction
  - a. Maintain good housekeeping practices.
  - b. Enclose or cover building material storage areas.
  - c. Properly store materials such as paints and solvents.
  - d. Store dry and wet materials under cover, away from drainage areas.
  - e. Avoid mixing excess amounts of fresh concrete or cement on-site.
  - f. Perform washout of concrete trucks off-site or in designated areas only.
  - g. Do not place concrete washout water on-site.
  - h. Do not place material or debris into streams, gutters or catch basins that slope or reduce the flow of runoff water.
  - i. All public streets and storm drain facilities shall be maintained free of building materials, mud and debris caused by grading or construction operations. Roads will be swept within 1000' of construction entrance daily, if necessary.
  - j. Install straw wattle around all inlets contained within the development and all others that receive runoff from the development.
7. Erosion Control Plan Notes
  - a. The contractor will designate an emergency contact that can be reached 24 hours a day 7 days a week.
  - b. The contractor will designate an emergency contact that can be reached 24 hours a day 7 days a week.
  - c. Necessary materials shall be available on site and stockpiled at convenient locations to facilitate rapid construction of emergency devices when rain or runoff is eminent.
  - d. Erosion control devices shown on the plans and approved for the project may not be removed without approval of the engineer of record. If devices are removed, no work may continue that have the potential of erosion without consulting the engineer of record. If deemed necessary erosion control should be reestablished before this work begins.
  - e. Graded areas adjacent to fill slopes located at the site perimeter must drain away from the top of the slope at the conclusion of each working day. This should be confirmed by survey or other means acceptable to the engineer of record.
  - f. All soil and debris shall be removed from all devices within 24 hours after each rain or runoff event.
  - g. Except as otherwise approved by the inspector, all removable protective devices shown shall be in place at the end of each working day and through weekends until removal of the system is approved.
  - h. All loose soil and debris, which may create a potential hazard to offsite property, shall be removed from the site as directed by the Engineer of record of the governing agency.
  - i. The placement of additional devices to reduce erosion damage within the site is left to the discretion of the Engineer of record.
  - j. Desilting basins may not be removed or made inoperable without the approval of the engineer of record and the governing agency. Devices will be modified as needed as the project progresses, and plans of these changes submitted for approval by the engineer of record and the governing agency.
8. Conduct a minimum of one inspection of the erosion and sediment controls every two weeks. Maintain documentation on site.
  - a. Part III.D.4 of general permit UTR300000 identifies the minimum inspection requirements.
  - b. Part III.D.4.C identifies the minimum inspection report requirements.
  - c. Failure to complete and/or document storm water inspections is a violation of part III.D.4 of Utah General Permit UTR 300000.

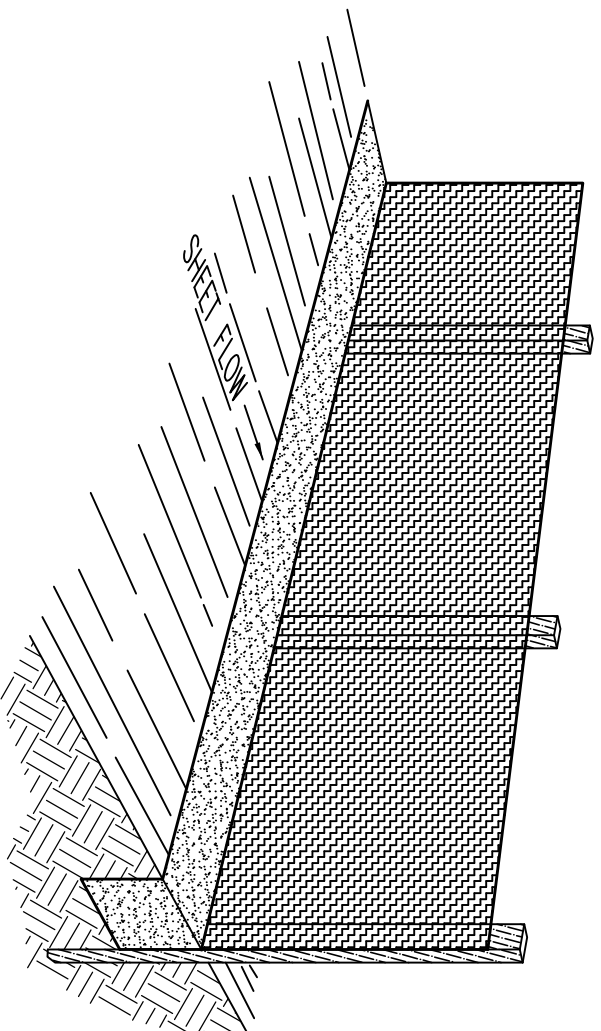

## Perspective View

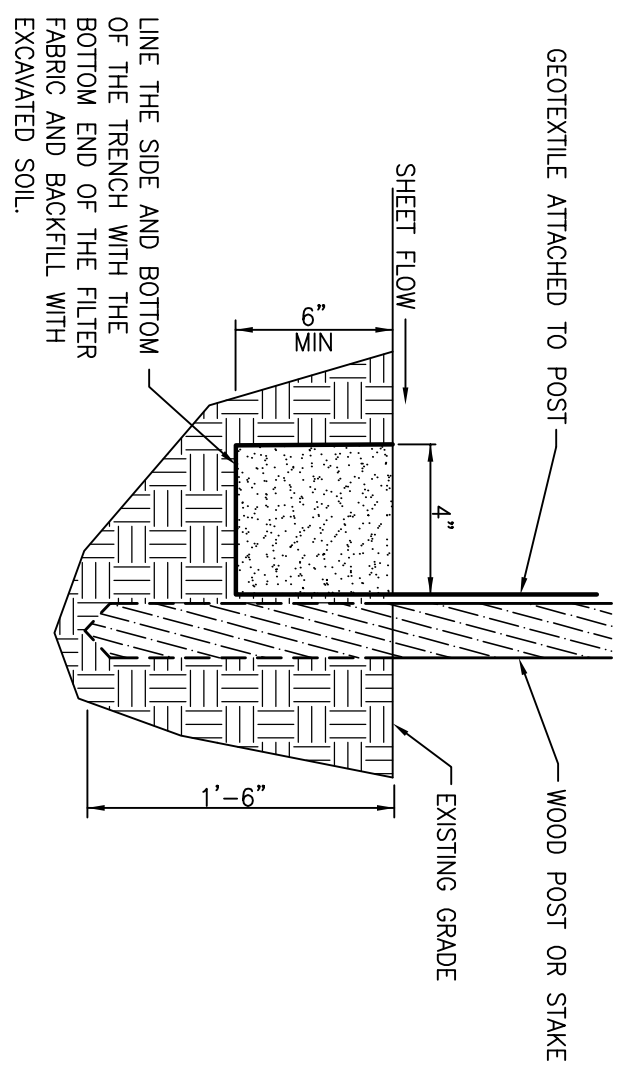

## Section

**INSTALLATION**  
The silt fence should be installed prior to major earthwork. The silt fence should be installed on the slope along a line of uniform elevation wherever flow of sediment is anticipated. Table 1 shows generally-recommended maximum slope lengths (slope spacing between fences) at various site grades for most silt fence applications.

Slope Steepness (%)	Max. Slope Length (ft)
<2%	30.5m (100ft)
2-5%	22.9m (75ft)
5-10%	15.2m (50ft)
10-20%	7.6m (25ft)
>20%	4.5m (15ft)

### PREFABRICATED SILT FENCE ROLLS

- \*Fabricate a minimum 15.2cm x 15.2cm (6"x6") trench at the desired location.
- \*Rolls of fabric should be unrolled and fastened against the downstream wall of the trench.
- \*Adjacent rolls of silt fence should be joined by nesting the end post of one fence into the other. Before nesting the end posts, rotate each post until the geotextile is wrapped completely around the post, then shown in Figure 1.
- \*Drive posts into the ground until the required fence height and/or anchorage depth is obtained.
- \*Bury the loose geotextile at the bottom of the trench in the upstream trench and backfill with natural soil, tamping the backfill.
- \*Figure 2 illustrates a typical silt fence installation and anchor trench placement.

### FIELD ASSEMBLY:

- \*Fabricate a minimum 15.2cm x 15.2cm (6"x6") trench at the desired location.
- \*Rolls of fabric should be unrolled and fastened against the downstream wall of the trench. Maximum post spacing should be 2.4-3.0m (8-10ft). Post spacing

should generally be less than three (3) times the height of the fence. If the mesh is required to reinforce the geotextile, it shall have a minimum mesh opening of 15.2cm (6").  
\*Fasten the mesh to the upslope side of the posts using heavy duty wire staples, the wires of the fence. Extend the mesh into the bottom of the trench. The mesh shall then be stapled or wired to the posts. An extra 20-50cm (8-20") of geotextile shall extend into the trench.

**INSPECTION**  
Inspect the silt fence daily during periods of rainfall, immediately after significant rainfall. Make any repairs immediately.  
When sediment deposits behind the silt fence one one-third of the fence height, remove and properly dispose of the sediment. Avoid damage to the fabric during demount.

**REMOVAL**  
Silt fence should not be removed until construction ceases and the upslope area has been properly stabilized and/or revegetated.

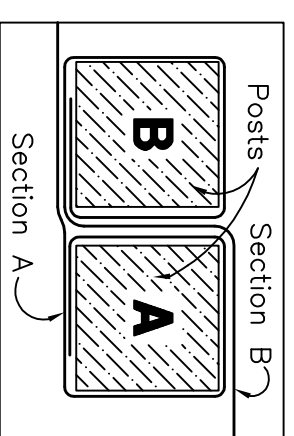
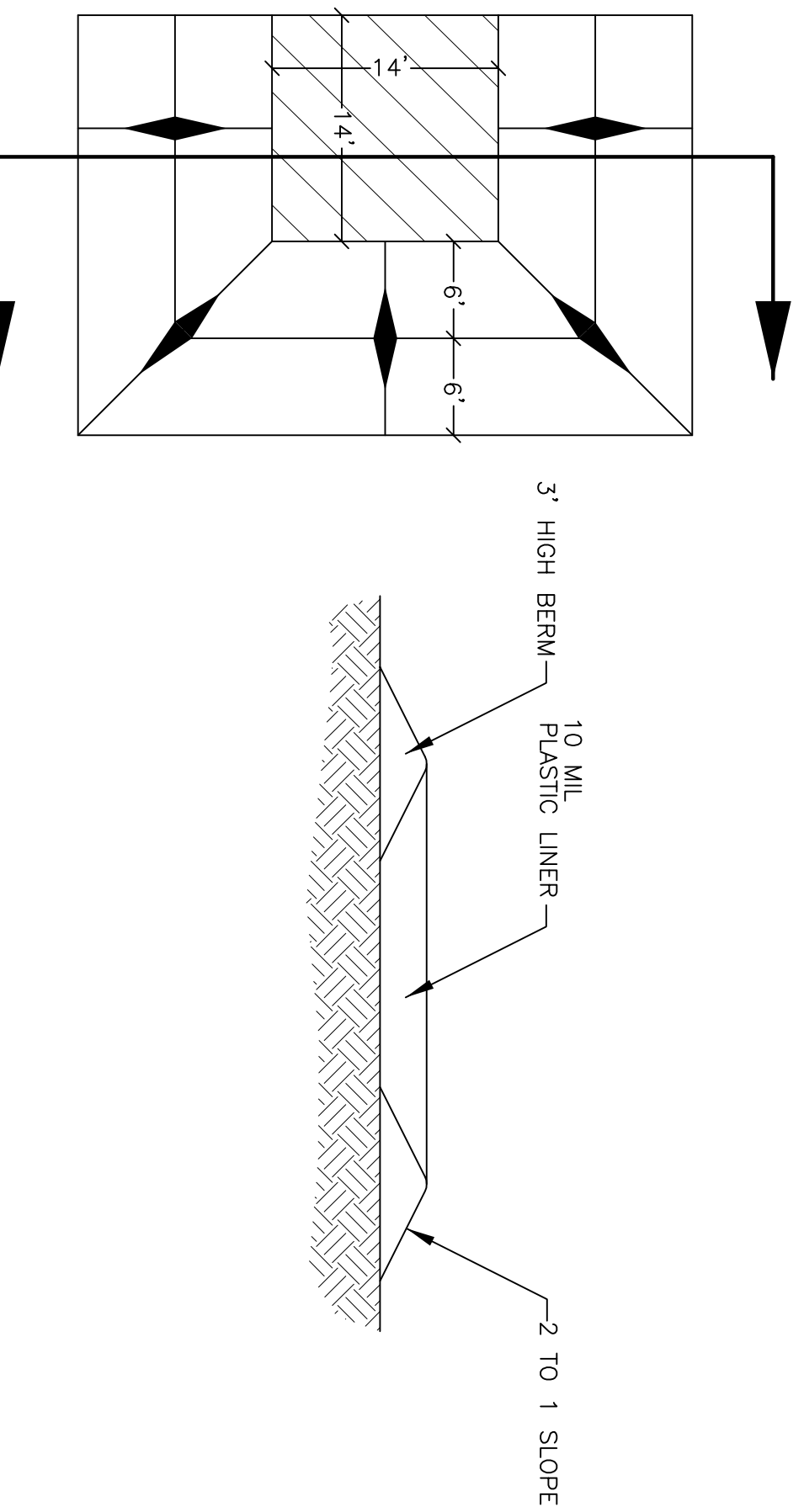

Figure 1:  
Top View of Roll-to-Roll Connection

## Silt Fence Detail

SCALE: NONE



## Concrete Washout Area w/ 10 mil Plastic Liner

SCALE: NONE

# J & K Homestead

WEBER COUNTY, UTAH

## Storm Water Pollution Prevention Plan Details

### REVISIONS

DATE	DESCRIPTION

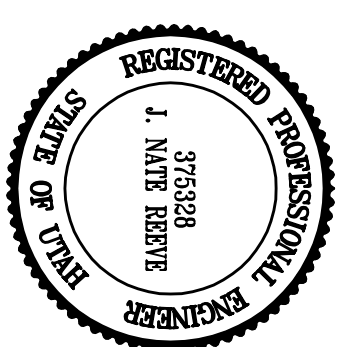

### Project Info.

Engineer: J. NATE REEVE, P.E.  
 Draft: S. TAGGART  
 Begin Date: DEC. 6, 2012  
 Name: J & K HOMESTEAD  
 SUBDIVISION:  
 Number: 3339-08