



# Land Use Permit

## Weber County Planning Commission

2380 Washington Blvd. STE 240  
Ogden, UT 84401  
Phone: (801) 399-8791 FAX: (801) 399-8862  
webercountyutah.gov/planning

**Permit Number: LUP227-2018**

Permit Type: Structure  
Permit Date: 08/16/2018

### Applicant

**Name:** Rocky Baker  
**Business:**  
**Address:**  
, UT  
**Phone:** 801-706-3583

### Owner

**Name:** Blake Kingsbury  
**Business:**  
**Address:** 8492 E Spring Park  
Eden, UT 84310  
**Phone:** 904-710-8011

### Parcel

**Parcel:** 231300037  
**Zoning:** DRR-1 **Area:** .0637 **Sq Ft:**  
**Address:** 8492 E Spring Park Eden, UT 84310

**Lot(s):** 70 **Subdivision:** Summ. Eden Ph1C  
**T - R - S - QS:** 7N - 2E - 8 - NE

### Proposal

**Proposed Structure:** SFD  
**Proposed Structure Height:** 28  
**# of Dwelling Units:**  
**# Off Street Parking Reqd:**

**Building Footprint:** 2000  
**Max Structure Height in Zone:** 35  
**# of Accessory Bldgs:**  
**\*Is Structure > 1,000 Sq. Ft?** Yes  
**\*If True Need Certif. Statement**

### Permit Checklist

**Access Type:** Front Lot Line  
**Greater than 4218 ft above sea level?** Yes  
**Additional Setback Reqd. ?** No  
**> 200 ft from paved Road?** No

**Alternative Access File #**  
**Wetlands/Flood Zone?** No  
**Meet Zone Area Frontage?** Yes  
**Hillside Review Reqd?** Yes DR201805

**Culinary Water District:** Powder Mtn. Water & Waste Water System: Powder Mtn. Water & S

### Comments

All recommendations in both the geological report(s) submitted (project 594-004) , as well as the hillside review (file #HSR2018-05) approval must be followed. Setbacks are as follows: front - 0', side - 5', rear - 10'. Max structure height for the DRR-1 zone is 35'. Lot is located in a drinking water zone 3. Prohibited uses for zone 3 are found in Weber County LUC 108-18-6.

# Land Use Permit

## Structure Setback Graphic: New Dwelling, Addition, Etc.

**\*\*See additional notes in the comments section\*\***

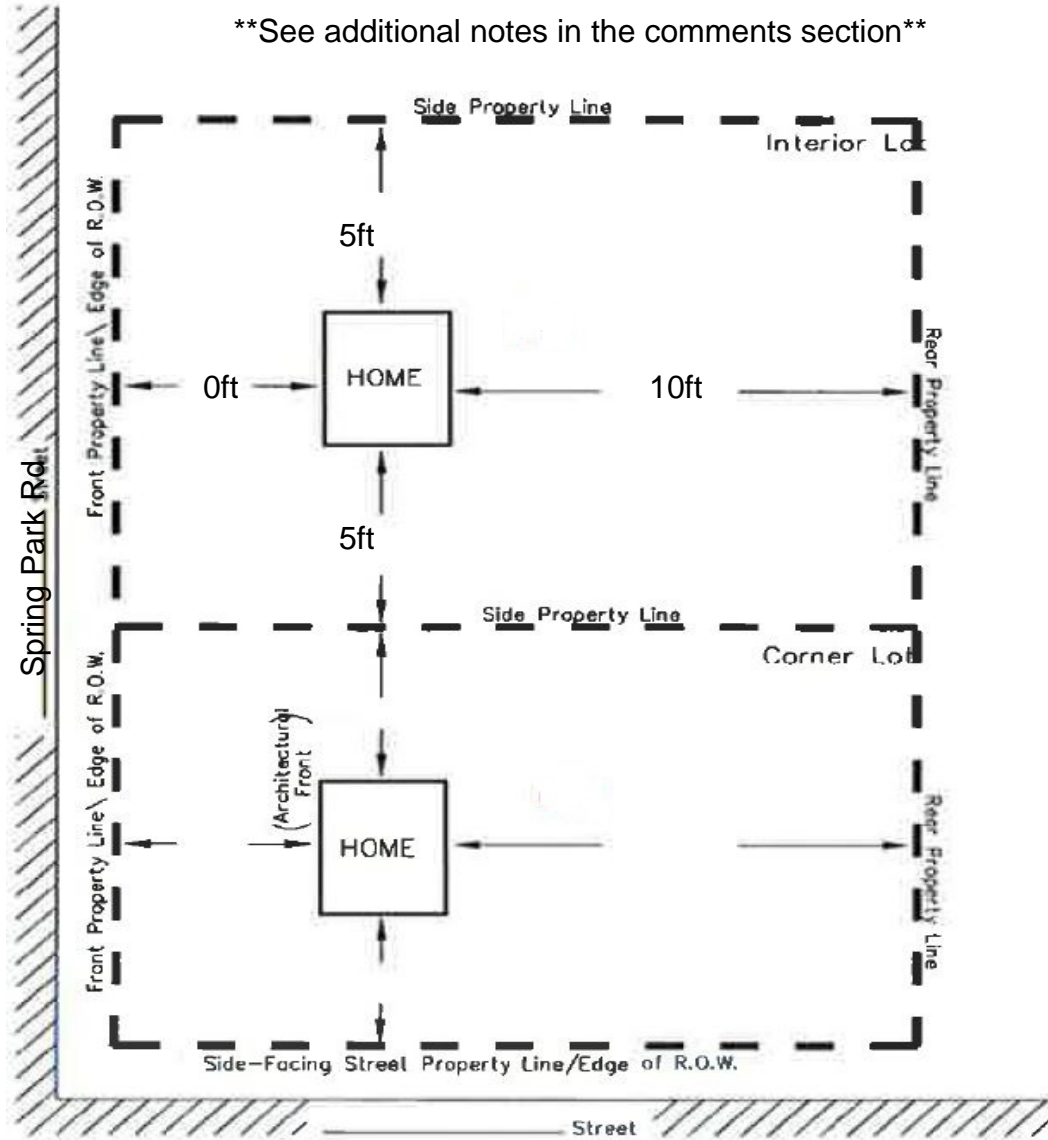

## MINIMUM YARD SETBACKS New Dwelling, Addition, Etc.

### NOTICE FOR APPLICANT (Please Read Before Signing)

Proposals for the installation of an individual water supply and for a sanitary waste disposal system (septic tank) for any structure designed for human occupation must be approved by Weber County Health Department prior to installation.

**Tammy Aydelotte**

**08/16/2018**

Planning Dept. Signature of Approval

Date

I hereby certify that I have read and examined this application and know the same to be true and correct. All provisions of laws and ordinances governing this land use will be complied with whether specified herein or not. I make this statement under penalty of perjury.

Contractor/Owner Signature of Approval

Date