



RIDGE NEST 14 AT SUMMIT POWDER MOUNTAIN

Eden, UT 84310

PLAN REVIEW ACCEPTANCE	
FOR COMPLIANCE WITH THE APPLICABLE CONSTRUCTION CODES IDENTIFIED BELOW	
<input checked="" type="checkbox"/> BUILDING	<input checked="" type="checkbox"/> STRUCTURAL
<input checked="" type="checkbox"/> MECHANICAL	<input checked="" type="checkbox"/> PLUMBING
<input checked="" type="checkbox"/> ELECTRICAL	<input checked="" type="checkbox"/> ENERGY
<input type="checkbox"/> ACCESSIBILITY	<input type="checkbox"/> FIRE

PLAN REVIEW ACCEPTANCE OF DOCUMENTS DOES NOT AUTHORIZE CONSTRUCTION TO PROCEED IN VIOLATION OF ANY FEDERAL, STATE, OR LOCAL REGULATIONS.

BY **MEM** DATE 09/12/18
WEST COAST CODE CONSULTANTS, INC.

THESE PLANS ARE THE INTELLECTUAL PROPERTY OF IMBUE DESIGN, LLC AND ARE PROTECTED BY COMMON LAW, STATUTORY AND OTHER RESERVED RIGHTS INCLUDING, BUT NOT LIMITED TO, COPYRIGHT. THESE DRAWINGS MAY NOT BE REPRODUCED OR USED FOR ANY PURPOSE WITHOUT THE EXPLICIT WRITTEN CONSENT OF IMBUE DESIGN, LLC.

801.477.4174
949 Denver Street
SLC, Utah 84111

Ridge Nest 14 at Summit
Eden, Utah 84310

G1.0
COVER PAGE

Revision 2
Date: 09.23.18
Construction Documents

ABBREVIATIONS			
@	At	CLR	Clear(ance)
⊥	Center line	CM	Centimeter(s)
°	Degree	CONC	Concrete
∅	Diameter	CONT	Continuous
#	Pound or Number	CU	Cubic
(E)	Existing	DBL	Double
A/C	Air Conditioning	DEG	Degree
AFF	Above Finish Floor	DEMO	Demolish, Demolition
ALUM	Aluminum	DEPT	Department
ALT	Alternate	DN	Down
ANOD	Anodized	DET	Detail
APPOX	Approximate	DWG	Drawing
AUTO	Automatic	EA	Each
AUX	Auxiliary	ELEV	Elevation
AV	Audio/Visual	EQ	Equal
AVG	Average	EQUIP	Equipment
BATH	Bathroom	EST	Estimate(d)
BD	Board	EXT	Exterior
BF	Board Foot	F	Fahrenheit
BLDG	Building	FDN	Foundation
BOT	Bottom	FIG	Figure
CAB	Cabinet(ry)	FIN	Finish
CFM	Cubic Feet per Minute	FIX	Fixture
CIP	Cast-in-Place	FLR	Floor
CLG	Ceiling	FLEX	Flexible
		FPM	Feet per Minute
		FT	Foot (Feet)
		FJRR	Furred(ing)
		FUT	Future
		GA	Gauge
		GAL	Gallon
		GALV	Galvanized
		GC	General Contractor
		GPM	Gallons per Minute
		GYP	Gypsum Wallboard
		HB	Hose Bib
		HDR	Header
		HDWD	Hardwood
		HP	Horsepower
		HR	Hour
		HT	Height
		HVAC	Heating, Ventilation, A/C
		HWH	Hot Water Heater
		HWY	Highway
		ID	Inside Diameter
		IN	Inch(es)
		INT	Interior
		LAM	Laminated(d)
		LAV	Lavatory
		MAX	Maximum
		MECH	Mechanical
		MED	Medium
		MFR	Manufacturer
		MIN	Minimum
		MISC	Miscellaneous
		MM	Millimeter(s)
		MO	Masonry Opening
		NOM	Nominal
		NTS	Not to Scale
		OC	On Center(s)
		OD	Outside Diameter
		OFF	Office
		PCF	Pounds per Cubic Foot
		PCF	Pounds per Square Foot
		PSI	Pounds per Square Inch
		PT	Pressure Treated
		PVC	Polyvinyl Chloride
		QTY	Quantity
		RAD	Radius
		REFER	Refrigerator
		REQ'D	Required
		REV	Revision(s), Revised
		RO	Rough Opening
		RPM	Revolutions per Minute
		SCHED	Schedule
		SEC	Section, Second
		SPEC	Specification(s)
		SO	Square
		STRUCT	Structural
		TEMP	Tempered
		T&G	Tongue and Groove
		TOFF	Top Of Finish Floor
		TOW	Top of Wall
		TV	Television
		TYP	Typical
		UON	Unless Otherwise Noted
		VOL	Volume
		VIF	Verify in Field
		W	With
		W/O	Without

- ### GENERAL NOTES
- WORK PERFORMED SHALL COMPLY WITH THE FOLLOWING:
 - THESE GENERAL NOTES, PLANS AND SPECIFICATIONS.
 - ALL APPLICABLE LOCAL, STATE AND FEDERAL CODES, ORDINANCES AND REGULATIONS. ALL CODES LISTED IN SPECIFICATIONS AND DRAWINGS SHALL BE INCLUSIVE OF ALL CODES, REGULATIONS AND REQUIREMENTS ADOPTED BY THE STATE OF IDAHO INCLUDING ALL AMENDMENTS.
 - THE GENERAL CONTRACTOR IS RESPONSIBLE FOR ALL WORK REGARDLESS OF THE LOCATION OF INFORMATION IN THE DOCUMENTS. THE GENERAL CONTRACTOR SHALL UTILIZE THE CONSTRUCTION DRAWINGS AND WRITTEN SPECIFICATIONS FOR ALL REQUIRED INFORMATION TO PROVIDE COMPLETE CONSTRUCTION OF THIS PROJECT. ITEMS LISTED IN THE DRAWINGS MAY NOT BE INCLUDED IN SPECIFICATIONS. ITEMS IN SPECIFICATIONS MAY NOT BE INCLUDED IN DRAWINGS.
 - ONSITE VERIFICATION OF ALL DIMENSIONS AND CONDITIONS SHALL BE THE RESPONSIBILITY OF THE GENERAL CONTRACTOR. NOTED DIMENSIONS TAKE PRECEDENCE OVER SCALE. LARGER SCALE OVER SMALLER SCALE. ADDENDA AND CLARIFICATIONS OVER PREVIOUS DOCUMENTS. THESE DRAWINGS ARE NOT TO BE SCALED FOR CONSTRUCTION.
 - THE GENERAL NOTES AND TYPICAL DETAILS APPLY THROUGHOUT THE JOB UNLESS OTHERWISE NOTED OR SHOWN ON ALL DRAWINGS.
 - THE GENERAL CONTRACTOR SHALL REFERENCE ALL MANUFACTURER'S DETAILS, DATA SHEETS, OR APPROVED SHOP DRAWINGS FOR ALL CONSTRUCTION DETAILS NOT SHOWN. THESE DETAILS MUST BE SUBMITTED TO THE ARCHITECT / DESIGNER PRIOR TO CONSTRUCTION FOR APPROVAL.
 - DISCREPANCIES: THE GENERAL CONTRACTOR SHALL COMPARE AND COORDINATE THE INFORMATION SHOWN ON ALL DRAWINGS AND FOUND IN THE FIELD. IF ANY DISCREPANCIES EXIST, THE GENERAL CONTRACTOR SHALL PROMPTLY REPORT TO THE ARCHITECT / DESIGNER FOR CLARIFICATION AND/OR ADJUSTMENT.
 - OMISSIONS: IN THE EVENT THAT CERTAIN FEATURES OF THE CONSTRUCTION ARE NOT FULLY DETAILED ON THE DRAWINGS, THE CONSTRUCTION OF THOSE FEATURES SHALL BE COMPLETED IN THE SAME CHARACTER AS THE CONSTRUCTION OF SIMILAR CONDITIONS THAT ARE SHOWN OR NOTED ON THE DRAWINGS AND SPECIFICATIONS. IF THERE IS ANY DOUBT CONCERNING THE SIMILARITY OF THE CONDITION, THE CONTRACTOR SHALL NOTIFY THE ARCHITECT / DESIGNER AND REQUEST CLARIFICATION.
 - THE CONTRACTOR SHALL BE RESPONSIBLE FOR COORDINATION, INSTALLATION, AND HOOK-UP OF ALL ITEMS AND EQUIPMENT SPECIFIED, INSTALLED, AND/OR PROVIDED BY THE OWNER.
 - THE GENERAL CONTRACTOR SHALL VERIFY REQUIRED ROUGH OPENING SIZE FOR ALL DOORS AND WINDOWS.
 - ALL PLAN DIMENSIONS ARE REFERENCED FROM ROUGH FRAMING, UNLESS SPECIFIED PER PLAN.
 - THE GENERAL CONTRACTOR SHALL PROVIDE ALL BLOCKING, BACKING, AND ADDITIONAL SUPPORTING STRUCTURE AS REQUIRED FOR ITEMS CALLED FOR IN THE DRAWINGS AND SPECIFICATIONS WHETHER THE BLOCKING, BACKING, AND ADDITIONAL SUPPORTING STRUCTURE IS SPECIFICALLY SHOWN IN THE DRAWING OR NOT.
 - THE GENERAL CONTRACTOR SHALL VERIFY THAT THERE ARE NO CONFLICTS BETWEEN OPENINGS IN WALLS OR SLABS AND STRUCTURAL, MECHANICAL, ELECTRICAL AND / OR PLUMBING REQUIREMENTS. IN THE EVENT THAT A CONFLICT OCCURS THE CONTRACTOR SHALL NOTIFY THE ARCHITECT / DESIGNER IMMEDIATELY.
 - THE GENERAL CONTRACTOR SHALL COMPARE ALL DIMENSIONS FOUND IN THE STRUCTURAL DRAWINGS, ARCHITECTURAL DRAWINGS, AND THE FIELD PRIOR TO BEGINNING ANY PORTION OF THE PROJECT. ANY DISCREPANCIES OR CONFLICTS SHALL BE REPORTED TO THE ARCHITECT / DESIGNER IMMEDIATELY.
 - CONTRACT DOCUMENTS TAKE PRECEDENCE WHEN THEY ARE MORE STRINGENT THAN APPLICABLE CODES, ORDINANCES, STANDARDS AND STATUTES. CODES, ORDINANCES, STANDARDS AND STATUTES TAKE PRECEDENCE WHEN THEY ARE MORE STRINGENT OR CONFLICT WITH DRAWINGS AND SPECIFICATIONS.
 - A BLOWER DOOR TEST @ 50 PA. SHALL PRODUCE < OR = TO 5 ACH PER IECC 402.4.2 AND 402.4.2.1
 - OWNER SHALL INVITE IMBUE DESIGN, PROJECT CONSULTANTS, CONTRACTORS AND SUBCONTRACTORS TO A FANCY WINE AND CHEESE HOUSE CHRISTENING EVENT UPON RECEIPT OF CERTIFICATE OF OCCUPANCY.
 - WOOD-BURNING FIREPLACES SHALL HAVE TIGHT FITTING FLUE DAMPERS AND OUTDOOR AIR FOR COMBUSTION PER IECC 402.4.2

INDEX OF DRAWINGS

ARCHITECTURAL	STRUCTURAL
G1.0 COVER PAGE	S1 GENERAL NOTES
E1.0 GENERAL INFORMATION	S1.1 DETAILS + SCHEDULES
ET01 SURVEY	S1.2 DETAILS + SCHEDULES
AS1 SITE PLAN	S2 LOW FOUNDATION PLAN
AS2 SWPPP	S3 UPPER FND + FRAMING PLANS
A1.0 FLOOR PLANS	S4 SHEAR WALL PLANS
A1.1 ROOF PLAN	SD-1 FOUNDATION DETAILS
A1.2 FDN + FOOTING	SD-2 STRUCTURAL DETAILS
A2.0 ELEVATIONS	
A2.1 ELEVATIONS	
A2.2 WINDOW + DOOR SCHED	
A3.0 BUILDING SECTIONS	
A3.1 BUILDING SECTIONS	
A3.2 WALL SECTIONS	
A3.3 DETAILS	
E1.0 ELECTRICAL PLAN	
E1.1 ELECTRICAL PLAN	
M1.0 MECHANICAL	

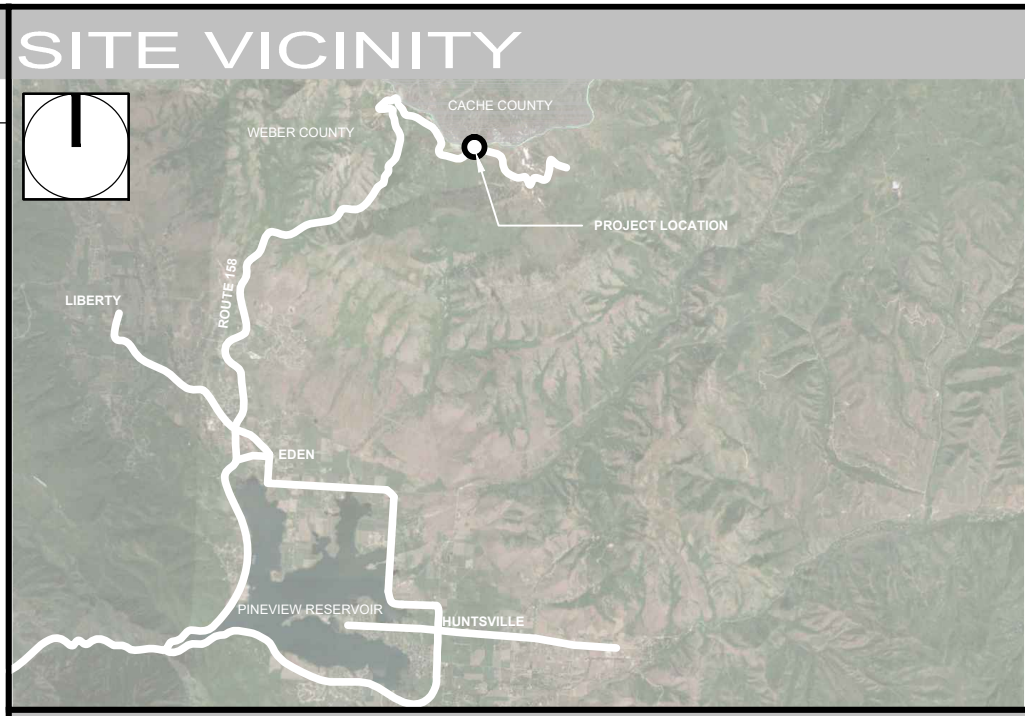

SITE / BUILDING INFO

PROJECT ADDRESS	7918 E HEARTWOOD DR EDEN, UT 84310
PARCEL ID	16-111-0014
ZONING	RR - RESORT RECREATION
OVERLAY ZONES	WILDLAND URBAN INTERFACE
LOT	14R
LOT AREA	5,816 SQ FT [0.13 ACRES]
ELEVATION	8,800 FT
LATITUDE / LONGITUDE	41°22'10" N , 111°45'31" W
SOLAR ALTITUDE	72.05° (JUN 21 NOON), 25.22° (DEC 21 NOON)
PROJECT SCOPE	NEW-BUILD, SINGLE FAMILY RESIDENCE
BUILDING USE	RESIDENTIAL
UPPER LIVABLE AREA	885 SQ FT
LOWER LIVABLE AREA	701 SQ FT
TOTAL LIVABLE AREA	1,586 SQ FT
ROOF AREA	1,500 SQ FT
TOTAL FOOTPRINT	1,204 SQ FT

CODE INFO

BUILDING CODES	2015 INTL RESIDENTIAL CODE
CONSTRUCTION TYPE	TYPE VB, LIGHT WOOD FRAME W/ STEEL
ENERGY CODE	2015 INTL ENERGY CONSERVATION CODE

DEFERRED SUBMITTALS

--	--

PROJECT DIRECTORY

OWNER	STRUCTURAL ENGINEER
CIPRIAN MORAR	VECTOR ENGINEERING
60 WATER STREET, UNIT 912 BROOKLYN, NY 11201	651 W GALENA PARK BLVD, SUITE 101 DRAPER, UT 84016
	CONTACT : JOE SHARP
650.380.8261	801.990.1775
CIPRIAN@LATERAL-INC.COM	JOE@VECTORSE.COM

DESIGNER	GENERAL CONTRACTOR
IMBUE DESIGN	TBD
949 DENVER STREET SALT LAKE CITY, UT 84111	
801.477.4174	
INFO@IMBUDESIGN.COM	
HUNTER GUNDERSEN 801.631.6911	SCOTT CLEMENTS 801.699.4571

GEOTECH + GEOLOGIST	DEVELOPER
IGES INC	SUMMIT POWDER MOUNTAIN
12429 SOUTH 300 EAST, SUITE 100 DRAPER, UTAH 84120	
801.748.4044	LIVING.POWDERMOUNTAIN.COM
WWW.IGESINC.COM	sarthur@powdermountain.com>
DAVID A. GLASS, P.E. 801.748.4044	SAM ARTHUR 949.370.2558

SYMBOLS LEGEND

DRAWING REFERENCE	Drawing Title SCALE 1/4" = 1'-0"
SECTION REFERENCE	SECTION REFERENCE
DETAIL SECTION REFERENCE	DETAIL SECTION REFERENCE
DETAIL REFERENCE	DETAIL TITLE DETAIL 'A' SHEET A1.0
WALL SECTION REFERENCE	DETAIL TITLE DETAIL 'A' SHEET A1.0
NORTH ARROW	
ELEVATION REFERENCE	
DOOR REFERENCE	
WINDOW REFERENCE	
KEYED NOTE	
ELEVATION MARKER	SURFACE DESCRIPTION EL. = 100'-0"
BREAK LINE	

MATERIALS LEGEND

PLAN	ELEVATION	SECTION
	ASPHALT	N/A
	GRAVEL	PLASTER / EIFS
	WOOD VENEER	WOOD
	SPECIAL TILE PATTERN	ENGINEERED WOOD / PLYWOOD
	BLOWN-IN / SPRAY INSULATION	BLOWN-IN / SPRAY INSULATION
	N/A	PERFORATED METAL SCREEN
	FLOOR TILE	RIGID INSULATION
	WOOD DECKING	T+G SIDING
	CONCRETE	CONCRETE
	EARTH BELOW GRADE	SHADOWS
	LEDGE STONE PAVERS	STONE VENEER
		N/A

PLAN REVIEW ACCEPTANCE
FOR COMPLIANCE WITH THE APPLICABLE CONSTRUCTION CODES IDENTIFIED BELOW

<input checked="" type="checkbox"/> BUILDING	<input checked="" type="checkbox"/> STRUCTURAL
<input checked="" type="checkbox"/> MECHANICAL	<input checked="" type="checkbox"/> PLUMBING
<input checked="" type="checkbox"/> ELECTRICAL	<input checked="" type="checkbox"/> ENERGY
<input type="checkbox"/> ACCESSIBILITY	<input type="checkbox"/> FIRE

PLAN REVIEW ACCEPTANCE OF DOCUMENTS DOES NOT AUTHORIZE CONSTRUCTION TO PROCEED IN VIOLATION OF ANY FEDERAL, STATE, OR LOCAL REGULATIONS.

BY: **MEM** DATE: 09/12/18
WEST COAST CODE CONSULTANTS, INC.

THESE PLANS ARE THE INTELLECTUAL PROPERTY OF IMBUE DESIGN, LLC AND ARE PROTECTED BY COMMON LAW, STATUTORY AND OTHER RESERVED RIGHTS INCLUDING, BUT NOT LIMITED TO, COPYRIGHT. THESE DRAWINGS MAY NOT BE REPRODUCED OR USED FOR ANY PURPOSE WITHOUT THE EXPLICIT WRITTEN CONSENT OF IMBUE DESIGN, LLC.

801.477.4174
 949 Denver Street
 SL, Utah 84111
imbue design
 ridge nest 14
G1.1
 GENERAL NOTES
 Revision 2
 Date: 09.23.18
 Construction Documents



#	KEYED NOTES
1	Gas meter
2	Intersystem bonding terminal
3	Electrical meter
4	Water meter - elevation benchmark at top of water meter lid
5	Chimney flue
6	Planted roof - seeded with native grasses and wildflowers
7	Reseed disturbed areas with native grasses and wildflowers
8	Deck - ipe wood or composite decking material
9	UFER Ground
10	Line of wall below
11	Concrete walkway + steps
12	Concrete retaining wall - <4' in height
13	Concrete patio [below] - radiant heated
14	Walkway + steps - ipe wood or composite decking material
15	Curb and gutter
16	Asphalt

GENERAL NOTES	
1 SITE PLAN	This drawing is not an official or certified survey. Property dimensions and conditions were taken from the survey prepared by Talisman Civil Consultants [dated July 17, 2017], public records and field measurements.
2 LIMITS OF DISTURBANCE	All construction activity shall be contained within the indicated limits of disturbance. The balance of the parcel shall remain undisturbed.
3 CONSTRUCTION FENCING	Contractor shall furnish and install fences wherever the planning commission determines based upon the recommendation of the chief building official that a hazardous condition may exist.
4 EXCAVATION	The Contractor shall be responsible for obtaining any permits required by the local authorities and governing bodies prior to commencing excavation work. No excavations shall be performed further than is necessary to complete the excavation work.
LANDSCAPING	All existing landscaping shall remain, except where fire mitigation requirements exist necessitating the thinning or pruning of brush and vegetation. Areas where landscaping and natural grade has been disturbed shall be re-seeded with native grasses. Contractor shall use best management practices when performing any work on landscaping, vegetation, and/or trees to mitigate damage to any areas of non-disturbance and neighboring property.
6 GRADING	All existing grade shall remain, except where noted in the site plan. No retaining walls shall exceed 4' in height.
7 STORM WATER DRAINAGE	All storm water runoff shall be managed and contained on site. No retention or detention facilities shall exist on site.
8 CONSTRUCTION MITIGATION	Construction parking/traffic may not block the street without a permit. Mud tracked onto the street must be cleaned prior to the end of the work day. The construction site must be maintained in a neat manner. Trash and other debris may not accumulate outside the dumpster.
5 UTILITIES	All utility locations are approximate and may not represent all utilities on site. Prior to all excavation work the Contractor shall contact Blue Stakes of Utah [800.662.4111] to locate all existing utilities. Where applicable, the Contractor shall obtain required permits for excavation in public right of ways. Utilities shall be coordinated with all local regulating authorities and utility companies.
6 POWER AND COMMUNICATION LINES	Power lines shall maintain minimum 12" clearance from communication lines in joint service trenches. Contractor shall coordinate all site and utility work with local regulating authorities and utility companies.
8 FUEL GAS LATERAL	Gas lateral shall maintain min. 36" clearance from all other parallel running utilities and min. 12" vertical clearance from crossing utilities. New pipe and meter installation and sizing to be coordinated with Questar.
9 FIRE SUPPRESSION	A fire suppression system shall be designed for and fitted to the structure by a licensed contractor in accordance with the Weber County Fire District, 2015 IRC, and NFPA

LEGEND	
	Property Lines
	County Boarder Line
	Setback Line
	Neighboring Property Setback Line
	Top / Toe of Slope
	Construction Fence
	Limits of Disturbance
	Water Lines - 2"
	Gas Lines - 1/2"
	Sanitary Lines - 4"
	Power Lines - underground
	Power line - overhead
	Proposed Grade
	Power Box
	Communications Line
	Communications Box
	Cleanout
	Cleanout w/ Exterior Grade Cover
	Fire Hydrant - existing
	Drainage Swale
	Drainage Direction
	Native Grasses
	Existing Tree - to remain

PLAN REVIEW ACCEPTANCE
 FOR COMPLIANCE WITH THE APPLICABLE CONSTRUCTION CODES IDENTIFIED BELOW:
 BUILDING STRUCTURAL
 MECHANICAL PLUMBING
 ELECTRICAL ENERGY
 ACCESSIBILITY FIRE
 PLAN REVIEW ACCEPTANCE OF DOCUMENTS DOES NOT AUTHORIZE CONSTRUCTION TO PROCEED IN VIOLATION OF ANY FEDERAL, STATE, OR LOCAL REGULATIONS.
 BY: MEM DATE: 09/12/18
 WEST COAST CODE CONSULTANTS, INC.

A Site Plan
 SCALE 1/8" = 1'-0"
 FOOTPRINT: 1,204 SQ FT
 LOT AREA: 0.13 ACRES
 NORTH POWDER RIDGE ROAD

THESE PLANS ARE THE INTELLECTUAL PROPERTY OF IMBOUE DESIGN, LLC AND ARE PROTECTED BY COMMON LAW, STATUTORY AND OTHER RESERVED RIGHTS INCLUDING, BUT NOT LIMITED TO, COPYRIGHT. THESE DRAWINGS MAY NOT BE REPRODUCED OR USED FOR ANY PURPOSE WITHOUT THE EXPLICIT WRITTEN CONSENT OF IMBOUE DESIGN, LLC.

801.477.4174
 949 Denver Street
 SLC, Utah 84111
 imboue design
 ridge nest 14
 AS1 SITE PLAN
 Revision 2
 Date: 03.23.18
 Construction Documents

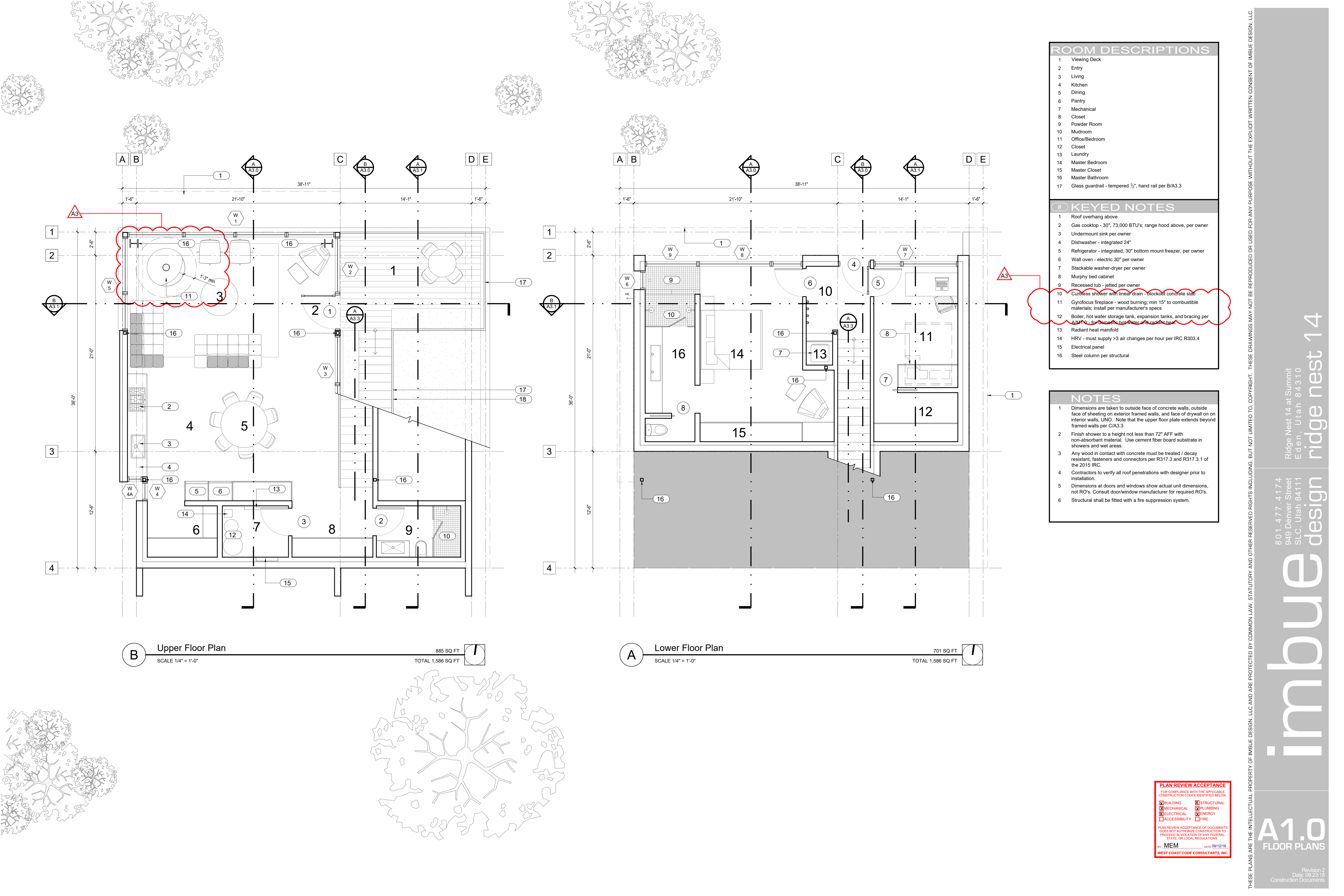

ROOM DESCRIPTIONS

- 1 Viewing Deck
- 2 Entry
- 3 Living
- 4 Kitchen
- 5 Dining
- 6 Pantry
- 7 Mechanical
- 8 Closet
- 9 Powder Room
- 10 Mudroom
- 11 Office/Bedroom
- 12 Closet
- 13 Laundry
- 14 Master Bedroom
- 15 Master Closet
- 16 Master Bathroom
- 17 Glass guardrail - tempered 1/2", hand rail per B/A3.3

KEYED NOTES

- 1 Roof overhang above
- 2 Gas cooktop - 30", 73,000 BTU's; range hood above, per owner
- 3 Undermount sink per owner
- 4 Dishwasher - integrated 24"
- 5 Refrigerator - integrated, 30" bottom mount freezer, per owner
- 6 Wall oven - electric 30" per owner
- 7 Stackable washer-dryer per owner
- 8 Murphy bed cabinet
- 9 Recessed tub - jetted per owner
- 10 Curbside shower with linear drain - blockout concrete slab
- 11 Gyrofocus fireplace - wood burning; min 15" to combustible materials; install per manufacturer's specs
- 12 Boiler, hot water storage tank, expansion tanks, and bracing per A3.3.3 for seismic hot water and cold water
- 13 Radiant heat manifold
- 14 HRV - must supply >3 air changes per hour per IRC R303.4
- 15 Electrical panel
- 16 Steel column per structural

NOTES

- 1 Dimensions are taken to outside face of concrete walls, outside face of sheathing on exterior framed walls, and face of drywall on interior walls, UNO. Note that the upper floor plate extends beyond framed walls per CIA3.3
- 2 Finish shower to a height not less than 72" AFF with non-absorbent material. Use cement fiber board substrate in showers and wet areas.
- 3 Any wood in contact with concrete must be treated / decay resistant, fasteners and connectors per R317.3 and R317.3.1 of the 2015 IRC.
- 4 Contractors to verify all roof penetrations with designer prior to installation.
- 5 Dimensions at doors and windows show actual unit dimensions, not RO's. Consult door/window manufacturer for required RO's.
- 6 Structural shall be fitted with a fire suppression system.

B Upper Floor Plan
SCALE 1/4" = 1'-0"
895 SQ FT
TOTAL 1,586 SQ FT

A Lower Floor Plan
SCALE 1/4" = 1'-0"
701 SQ FT
TOTAL 1,586 SQ FT

PLAN REVIEW ACCEPTANCE
FOR COMPLIANCE WITH THE APPLICABLE CONSTRUCTION CODES IDENTIFIED BELOW.

<input checked="" type="checkbox"/> BUILDING	<input checked="" type="checkbox"/> STRUCTURAL
<input checked="" type="checkbox"/> MECHANICAL	<input checked="" type="checkbox"/> PLUMBING
<input checked="" type="checkbox"/> ELECTRICAL	<input checked="" type="checkbox"/> ENERGY
<input type="checkbox"/> ACCESSIBILITY	<input type="checkbox"/> FIRE

PLAN REVIEW ACCEPTANCE OF DOCUMENTS DOES NOT AUTHORIZE CONSTRUCTION TO PROCEED IN VIOLATION OF ANY FEDERAL, STATE, OR LOCAL REGULATIONS.

MEM DATE 09/12/18
WEST COAST CODE CONSULTANTS, INC.

THESE PLANS ARE THE INTELLECTUAL PROPERTY OF IMBUE DESIGN, LLC AND ARE PROTECTED BY COMMON LAW, STATUTORY AND OTHER RESERVED RIGHTS INCLUDING, BUT NOT LIMITED TO, COPYRIGHT. THESE DRAWINGS MAY NOT BE REPRODUCED OR USED FOR ANY PURPOSE WITHOUT THE EXPLICIT WRITTEN CONSENT OF IMBUE DESIGN, LLC.

801.477.4174
 949 Denver Street
 SLC, Utah 84111
imbue design
 ridge nest 14
A1.0
 FLOOR PLANS
 Revision 2
 Date: 03.23.18
 Construction Documents

#	KEYED NOTES
1	Chimney flue - painted to match window frames
2	Planted roof deck - native grasses and wildflowers
3	Metal parapet cap - painted to match window frames
4	Lpe wood decking - 1x8 planks, sealed
5	Lpe wood stair treads and risers
6	Concrete retaining wall
7	Glass guardrail - tempered 1/2", per A/A3.3, handrail per B/A3.3
8	Roof drain
9	Seamless blend of grade and planted roof

NOTES	
1	Contractors to verify all roof penetrations with designer prior to installation.
2	Structural shall be fitted with a fire suppression system

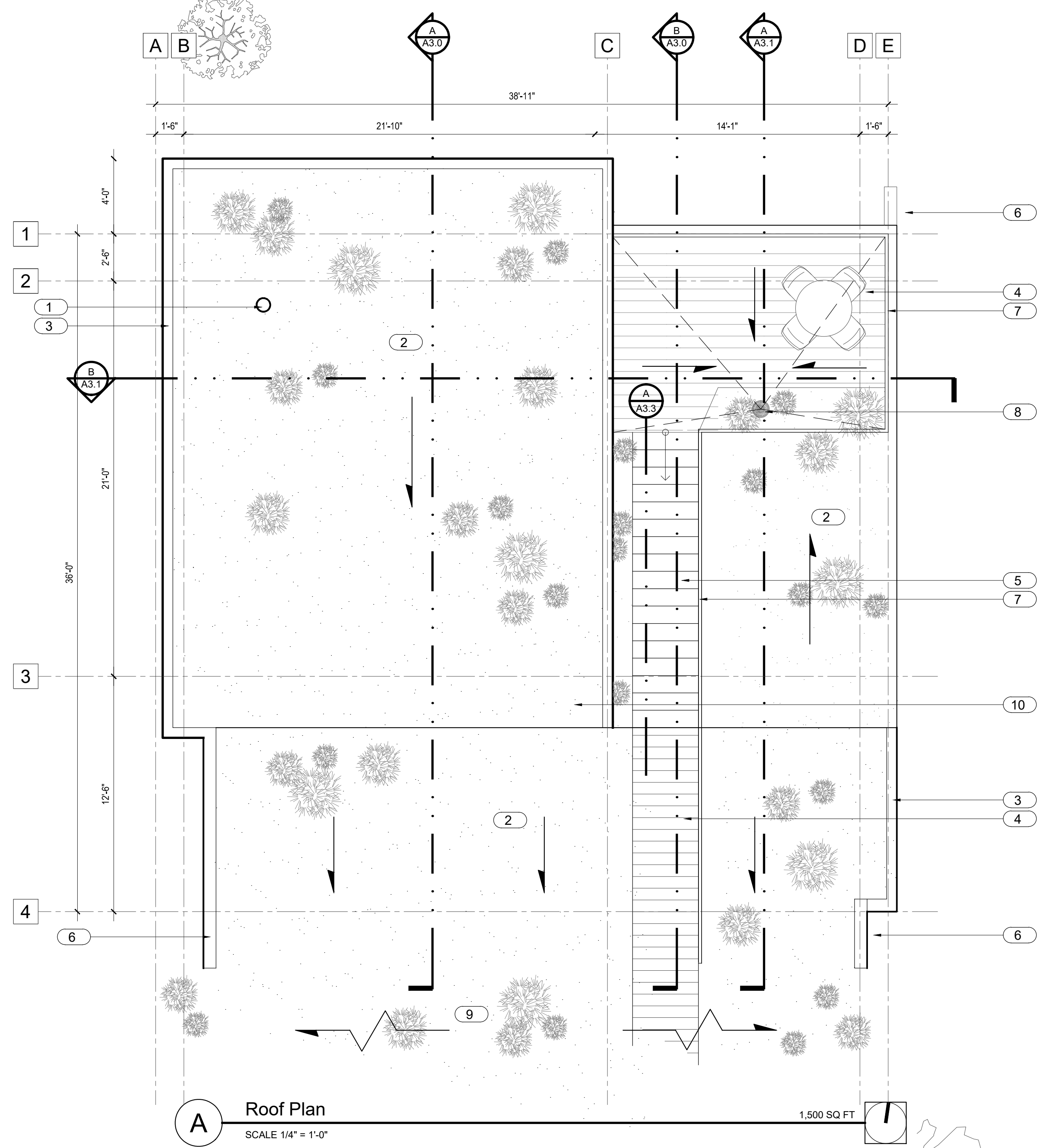

A Roof Plan
SCALE 1/4" = 1'-0"

1,500 SQ FT

PLAN REVIEW ACCEPTANCE
FOR COMPLIANCE WITH THE APPLICABLE CONSTRUCTION CODES IDENTIFIED BELOW.

<input checked="" type="checkbox"/> BUILDING	<input checked="" type="checkbox"/> STRUCTURAL
<input checked="" type="checkbox"/> MECHANICAL	<input checked="" type="checkbox"/> PLUMBING
<input checked="" type="checkbox"/> ELECTRICAL	<input checked="" type="checkbox"/> ENERGY
<input type="checkbox"/> ACCESSIBILITY	<input type="checkbox"/> FIRE

PLAN REVIEW ACCEPTANCE OF DOCUMENTS DOES NOT AUTHORIZE CONSTRUCTION TO PROCEED IN VIOLATION OF ANY FEDERAL, STATE, OR LOCAL REGULATIONS.

MEM 09/12/18
WEST COAST CODE CONSULTANTS, INC.

THESE PLANS ARE THE INTELLECTUAL PROPERTY OF IMBUE DESIGN, LLC AND ARE PROTECTED BY COMMON LAW, STATUTORY AND OTHER RESERVED RIGHTS INCLUDING, BUT NOT LIMITED TO, COPYRIGHT. THESE DRAWINGS MAY NOT BE REPRODUCED OR USED FOR ANY PURPOSE WITHOUT THE EXPLICIT WRITTEN CONSENT OF IMBUE DESIGN, LLC.

A1.1
ROOF PLAN

Revision 2
Date: 03/23/18
Construction Documents

801.477.4174
949 Denver Street
SLC, Utah 84111

design

Ridge Nest 14 at Summit
Eden, Utah 84310
ridge nest 14

imbue

# KEYED NOTES	
1	Retaining wall - less than 4' in height
2	Steel column per structural
3	Overhang above
4	Concrete footing per structural
5	Concrete foundation wall per structural
6	Top of foundation wall slopes down

NOTES	
1	This drawing is for dimensions and elevations only. Refer to structural drawings for all other foundation and footing information including sizing, components, details, structural data, etc.
2	Contact David Glass at IGES (801.748.4044) for observation and testing during site preparation, earthwork, and structural fill placement.

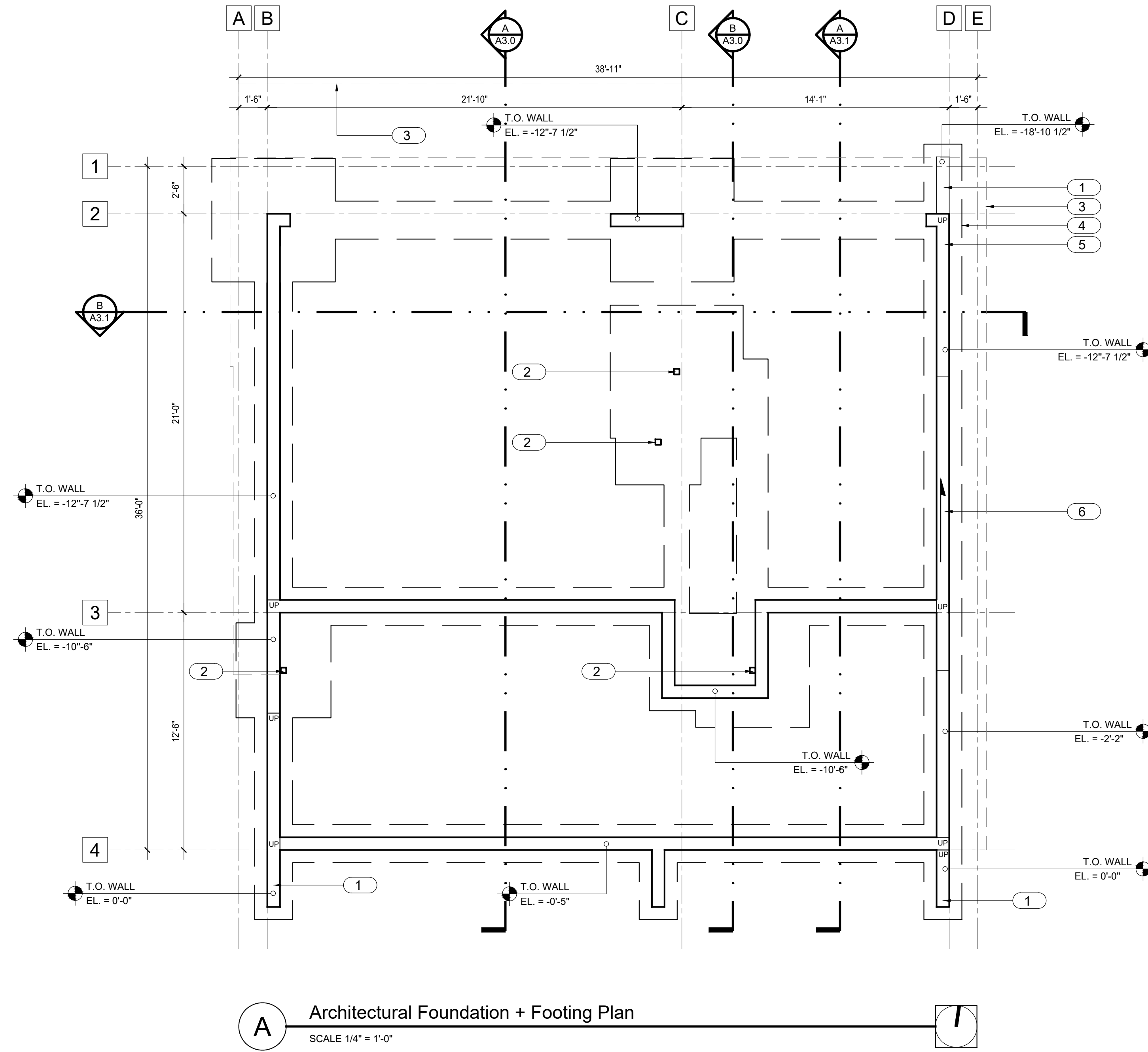

PLAN REVIEW ACCEPTANCE
FOR COMPLIANCE WITH THE APPLICABLE CONSTRUCTION CODES IDENTIFIED BELOW.

<input checked="" type="checkbox"/> BUILDING	<input checked="" type="checkbox"/> STRUCTURAL
<input checked="" type="checkbox"/> MECHANICAL	<input checked="" type="checkbox"/> PLUMBING
<input checked="" type="checkbox"/> ELECTRICAL	<input checked="" type="checkbox"/> ENERGY
<input type="checkbox"/> ACCESSIBILITY	<input type="checkbox"/> FIRE

PLAN REVIEW ACCEPTANCE OF DOCUMENTS DOES NOT AUTHORIZE CONSTRUCTION TO PROCEED IN VIOLATION OF ANY FEDERAL, STATE, OR LOCAL REGULATIONS.

MEM 09/12/18
WEST COAST CODE CONSULTANTS, INC.

THESE PLANS ARE THE INTELLECTUAL PROPERTY OF IMBUE DESIGN, LLC AND ARE PROTECTED BY COMMON LAW, STATUTORY AND OTHER RESERVED RIGHTS INCLUDING, BUT NOT LIMITED TO, COPYRIGHT. THESE DRAWINGS MAY NOT BE REPRODUCED OR USED FOR ANY PURPOSE WITHOUT THE EXPLICIT WRITTEN CONSENT OF IMBUE DESIGN, LLC.

801.477.4174
949 Denver Street
SLC, Utah 84111

imbue design

Ridge Nest 14 at Summit
Eden, Utah 84310

ridge nest 14

A1.2
ARCH FDN +
FOOTING PLAN

Revision 2
Date: 03.23.18
Construction Documents

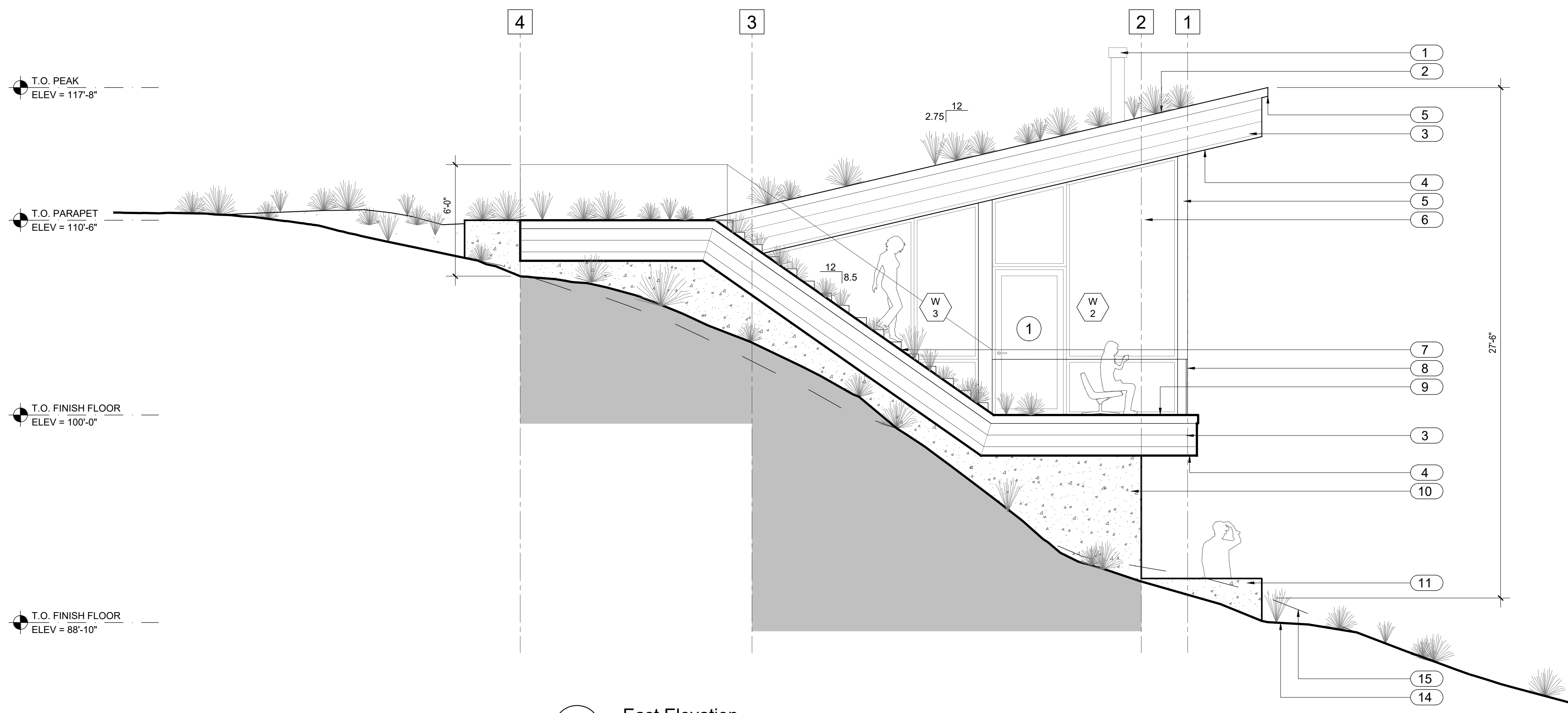

A East Elevation
SCALE 1/4" = 1'-0"

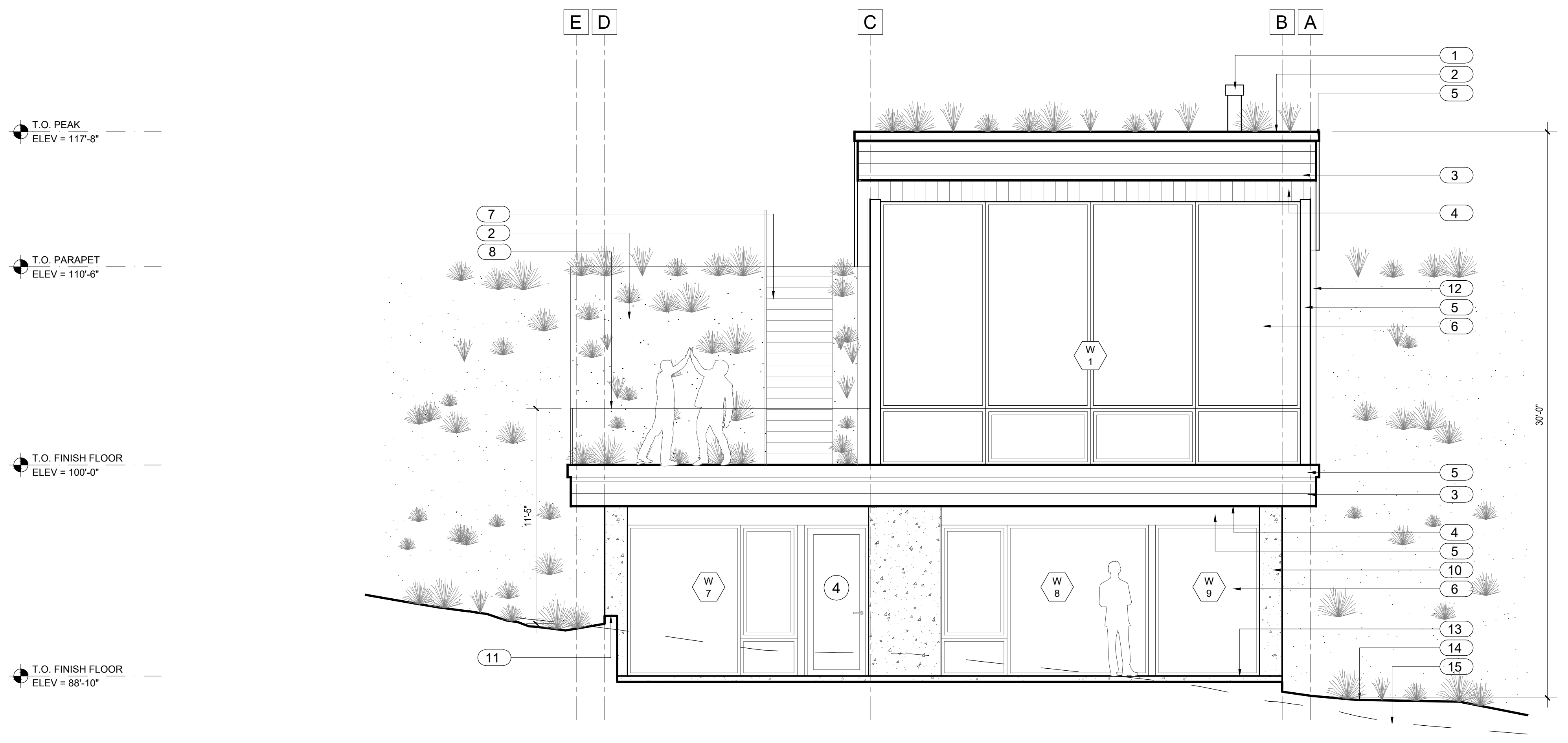

B North Elevation
SCALE 1/4" = 1'-0"

#	KEYED NOTES
1	Chimney flue with spark arrester - painted to match window frames
2	Planted roof deck
3	Cedar fascia - clear, 6" t+g, dark stained and sealed
4	Cedar soffit - clear, 6" t+g, dark stained and sealed
5	Steel members/panels/flashing - painted to match window frames
6	Aluminum clad wood window - dark bronze exterior frame color, triple-pane
7	Ipe wood stair treads and risers
8	Glass guardrail - tempered 1/2", per A/3.3, handrail per B/A3.3
9	Ipe wood decking - 1x6 planks, sealed
10	Concrete foundation wall
11	Concrete retaining wall
12	Cedar siding - clear, 6" t+g, dark stained and sealed
13	Concrete slab
14	Proposed grade
15	Existing grade

NOTES	
1	All exposed exterior structural wood members shall be exterior grade or protected with flashing caps and weather proof finishes
2	Foundation walls will be exposed. Care shall be taken to assure that they are protected from impact and breakage.

PLAN REVIEW ACCEPTANCE
FOR COMPLIANCE WITH THE APPLICABLE CONSTRUCTION CODES IDENTIFIED BELOW.

<input checked="" type="checkbox"/> BUILDING	<input checked="" type="checkbox"/> STRUCTURAL
<input checked="" type="checkbox"/> MECHANICAL	<input checked="" type="checkbox"/> PLUMBING
<input checked="" type="checkbox"/> ELECTRICAL	<input checked="" type="checkbox"/> ENERGY
<input type="checkbox"/> ACCESSIBILITY	<input type="checkbox"/> FIRE

PLAN REVIEW ACCEPTANCE OF DOCUMENTS DOES NOT AUTHORIZE CONSTRUCTION TO PROCEED IN VIOLATION OF ANY FEDERAL, STATE, OR LOCAL REGULATIONS.

MEM 09/12/18
WEST COAST CODE CONSULTANTS, INC.

THESE PLANS ARE THE INTELLECTUAL PROPERTY OF IMBUE DESIGN, LLC AND ARE PROTECTED BY COMMON LAW, STATUTORY AND OTHER RESERVED RIGHTS INCLUDING, BUT NOT LIMITED TO, COPYRIGHT. THESE DRAWINGS MAY NOT BE REPRODUCED OR USED FOR ANY PURPOSE WITHOUT THE EXPLICIT WRITTEN CONSENT OF IMBUE DESIGN, LLC.

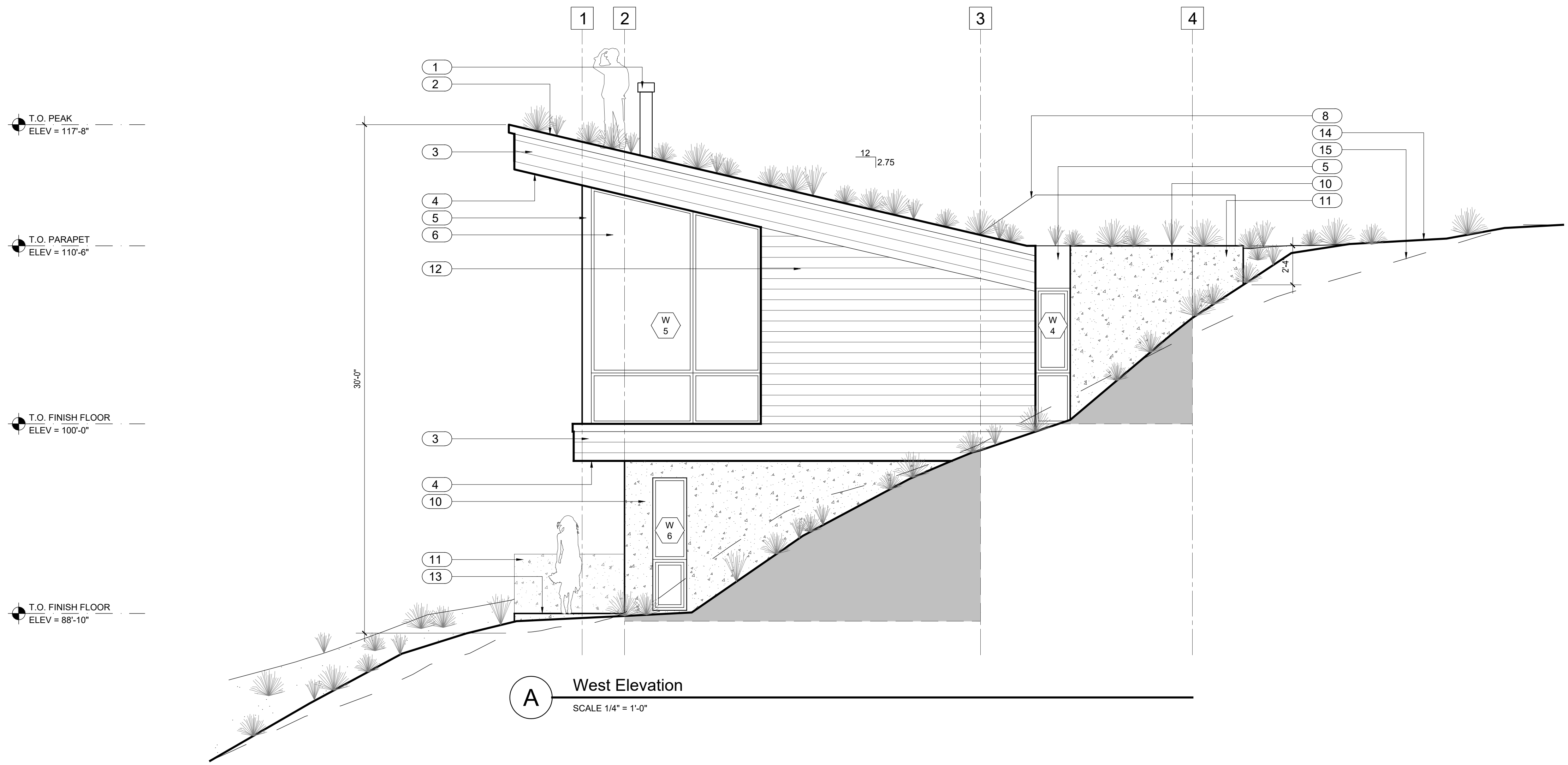

#	KEYED NOTES
1	Chimney flue - painted to match window frames
2	Planted roof deck
3	Cedar fascia - clear, 6" t+g, dark stained and sealed
4	Cedar soffit - clear, 6" t+g, dark stained and sealed
5	Steel members/panels/flashing - painted to match window frames
6	Aluminum clad wood window - dark bronze exterior frame color, triple-pane
7	Not used
8	Glass guardrail - tempered 1/2", per A/3.3, handrail per B/A3.3
9	Not used
10	Concrete foundation wall
11	Concrete retaining wall
12	Cedar siding - clear, 6" t+g, dark stained and sealed
13	Concrete slab
14	Proposed grade
15	Existing grade

NOTES	
1	All exposed exterior structural wood members shall be exterior grade or protected with flashing caps and weather proof finishes
2	Foundation walls will be exposed. Care shall be taken to assure that they are protected from impact and breakage.

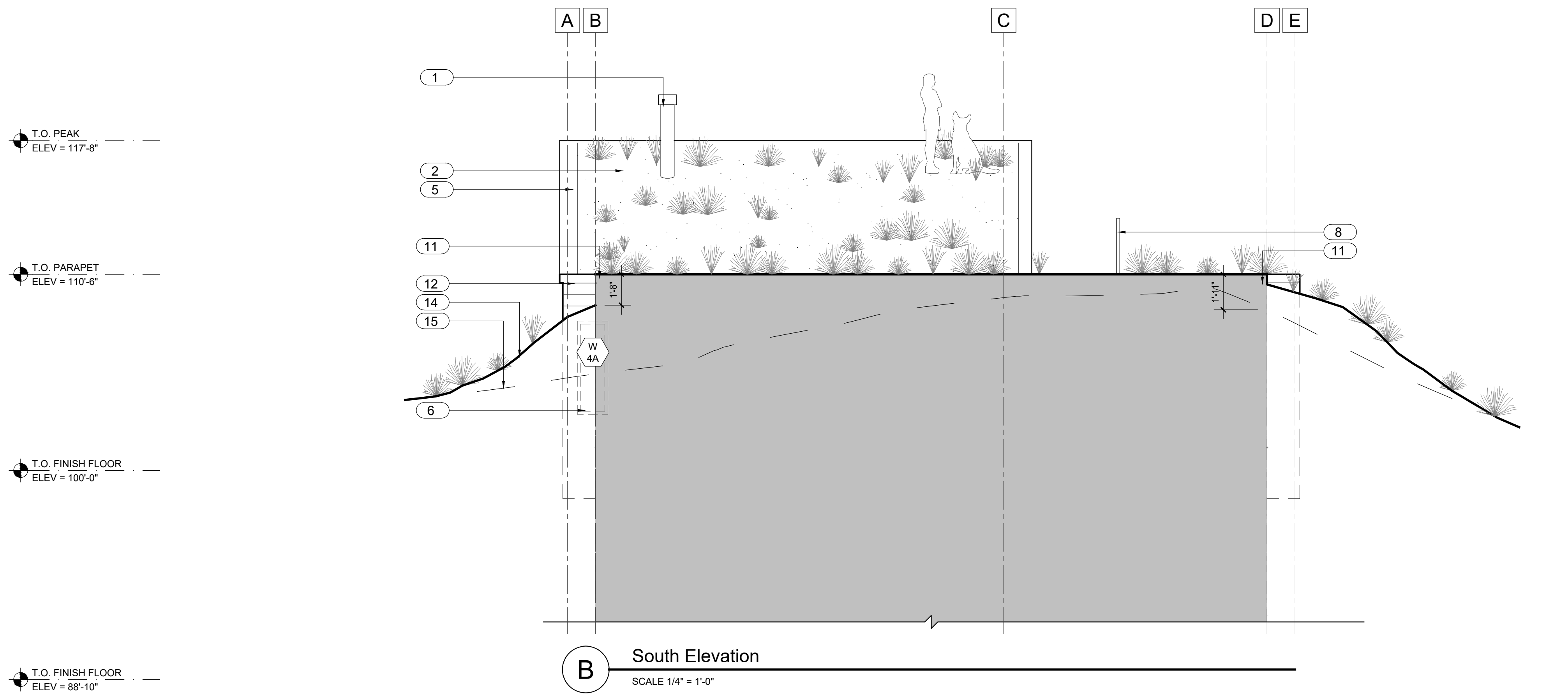

PLAN REVIEW ACCEPTANCE			
FOR COMPLIANCE WITH THE APPLICABLE CONSTRUCTION CODES IDENTIFIED BELOW.			
<input checked="" type="checkbox"/> BUILDING	<input checked="" type="checkbox"/> STRUCTURAL	<input checked="" type="checkbox"/> MECHANICAL	<input checked="" type="checkbox"/> PLUMBING
<input checked="" type="checkbox"/> ELECTRICAL	<input checked="" type="checkbox"/> ENERGY	<input type="checkbox"/> ACCESSIBILITY	<input type="checkbox"/> FIRE
PLAN REVIEW ACCEPTANCE OF DOCUMENTS DOES NOT AUTHORIZE CONSTRUCTION TO PROCEED IN VIOLATION OF ANY FEDERAL, STATE, OR LOCAL REGULATIONS.			
MEM		DATE: 09/12/18	
WEST COAST CODE CONSULTANTS, INC.			

THESE PLANS ARE THE INTELLECTUAL PROPERTY OF IMBUE DESIGN, LLC AND ARE PROTECTED BY COMMON LAW, STATUTORY AND OTHER RESERVED RIGHTS INCLUDING, BUT NOT LIMITED TO, COPYRIGHT. THESE DRAWINGS MAY NOT BE REPRODUCED OR USED FOR ANY PURPOSE WITHOUT THE EXPLICIT WRITTEN CONSENT OF IMBUE DESIGN, LLC.

801.477.4174
949 Denver Street
SLC, Utah 84111

imbué design

ridge nest 14

A2.1 ELEVATIONS

Revision 2
Date: 03.23.18
Construction Documents

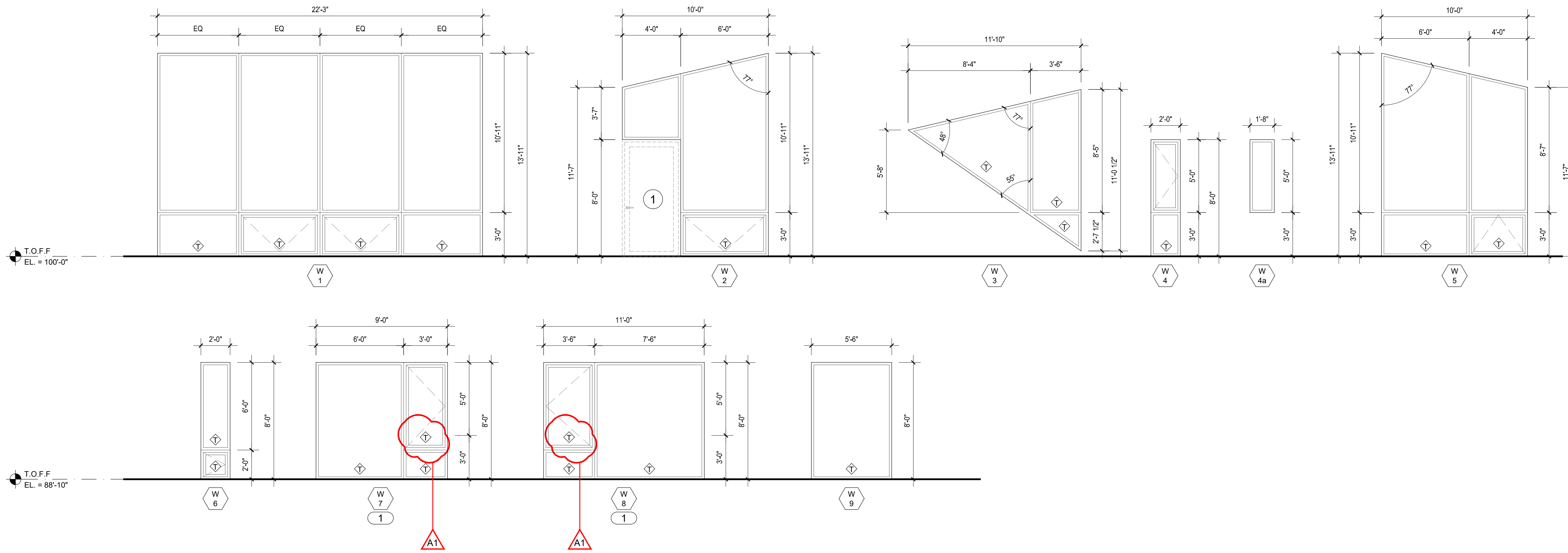

A Window Schedule
SCALE 1/4" = 1'-0"

- # KEYED NOTES**
- Window shall meet minimum egress clearance requirements per section R310 of the 2015 IRC
 - Manufacturer shall provide door hardware
 - Dummy hardware with ball catch
 - Keyed entry door hardware
 - Privacy door hardware
 - Passage door hardware
 - Pocket door hardware - privacy
 - Doors shall be keyed alike
- NOTES**
- All dimensions and conditions shall be verified by contractor prior to beginning work. Report any errors, inconsistencies, or omission to designer prior to beginning work.
 - All dimensions are for rough openings. Contractor and window / door suppliers shall field verify all window / door sizes, types, quantities, and swings prior to ordering.
 - All window / door types are drawn as viewed from the exterior. Window / door supplier shall reference all drawings regarding window / door type. Report to Designer with any errors, inconsistencies or omissions before ordering.
 - All window types and exterior doors shall be aluminum-clad wood, UNO. Exterior frame profile shall be square contemporary style with Shadow Line Frames at operable units. Windows shall be direct set where possible. Exterior finish shall be Extra Dark Anodized Aluminum. Interiors shall be square, contemporary style with stain grade finish and with square sticking, sashes, and frames at operable units. Hardware shall be black, contemporary style. Door tracks, frames, and thresholds shall be Extra Dark Anodized Aluminum where possible and black otherwise.
 - All glazing shall be triple pane insulated glass with low-e coating. All windows shall meet or exceed manufacturer's provided U-Factor of 0.25.
 - All exterior doors and windows shall meet or exceed values in REScheck specifications.
 - Window / door glass panes indicated in the window / door schedule shall be tempered
 - U-factors of fenestration shall be determined in accordance with NFRC test procedures unless otherwise authorized by local building authority.
 - Reference architectural floor plan A/A1.0 to determine each door swing.
 - All interior door jams shall be extended, paint grade, painted white per owner. All interior doors shall be paint grade, painted white per owner.

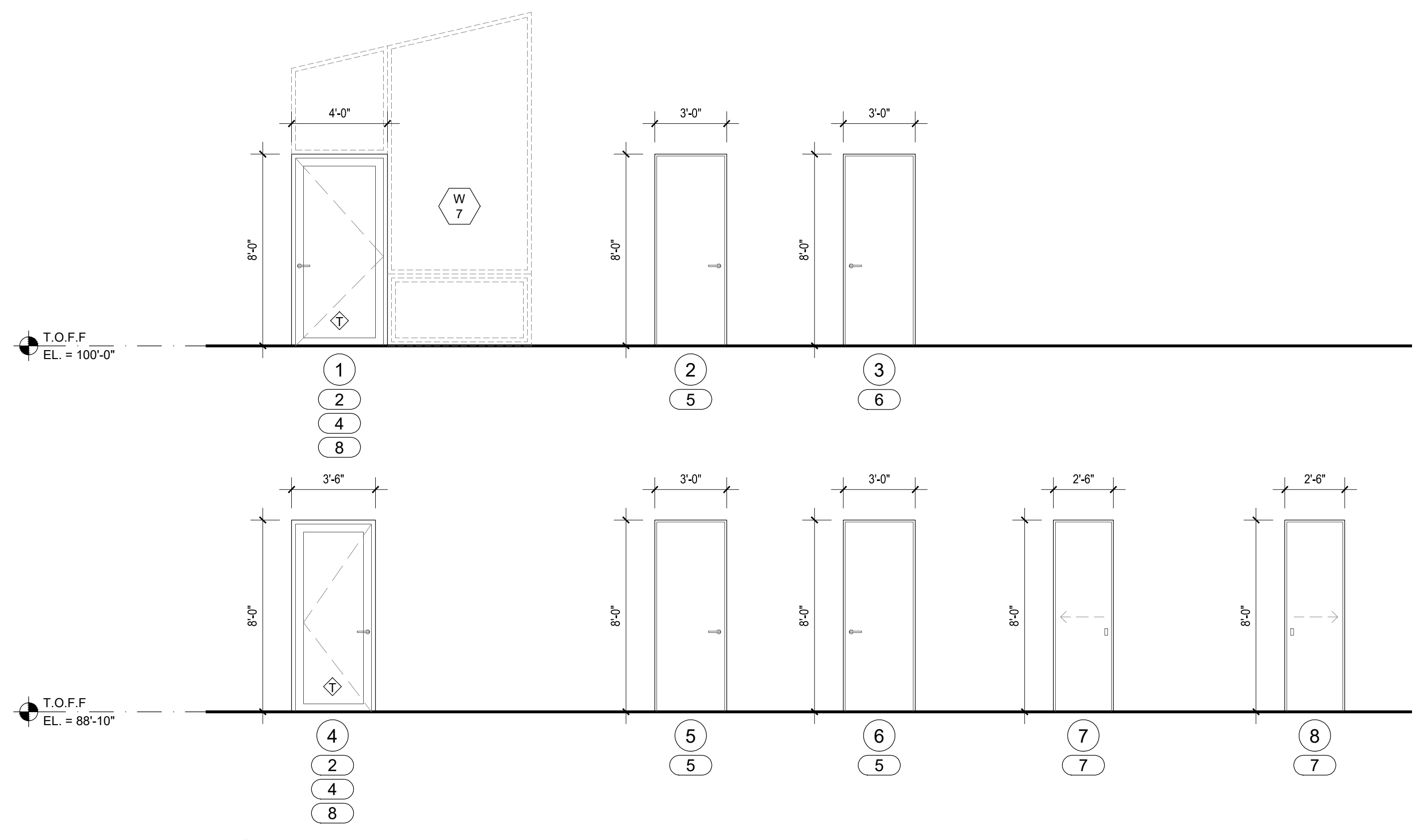

B Door Schedule
SCALE 1/4" = 1'-0"

PLAN REVIEW ACCEPTANCE
FOR COMPLIANCE WITH THE APPLICABLE CONSTRUCTION CODES IDENTIFIED BELOW.

<input checked="" type="checkbox"/> BUILDING	<input checked="" type="checkbox"/> STRUCTURAL
<input checked="" type="checkbox"/> MECHANICAL	<input checked="" type="checkbox"/> PLUMBING
<input checked="" type="checkbox"/> ELECTRICAL	<input checked="" type="checkbox"/> ENERGY
<input type="checkbox"/> ACCESSIBILITY	<input type="checkbox"/> FIRE

PLAN REVIEW ACCEPTANCE OF DOCUMENTS DOES NOT AUTHORIZE CONSTRUCTION TO PROCEED IN VIOLATION OF ANY FEDERAL, STATE, OR LOCAL REGULATIONS.

MEM 09/12/18
WEST COAST CODE CONSULTANTS, INC.

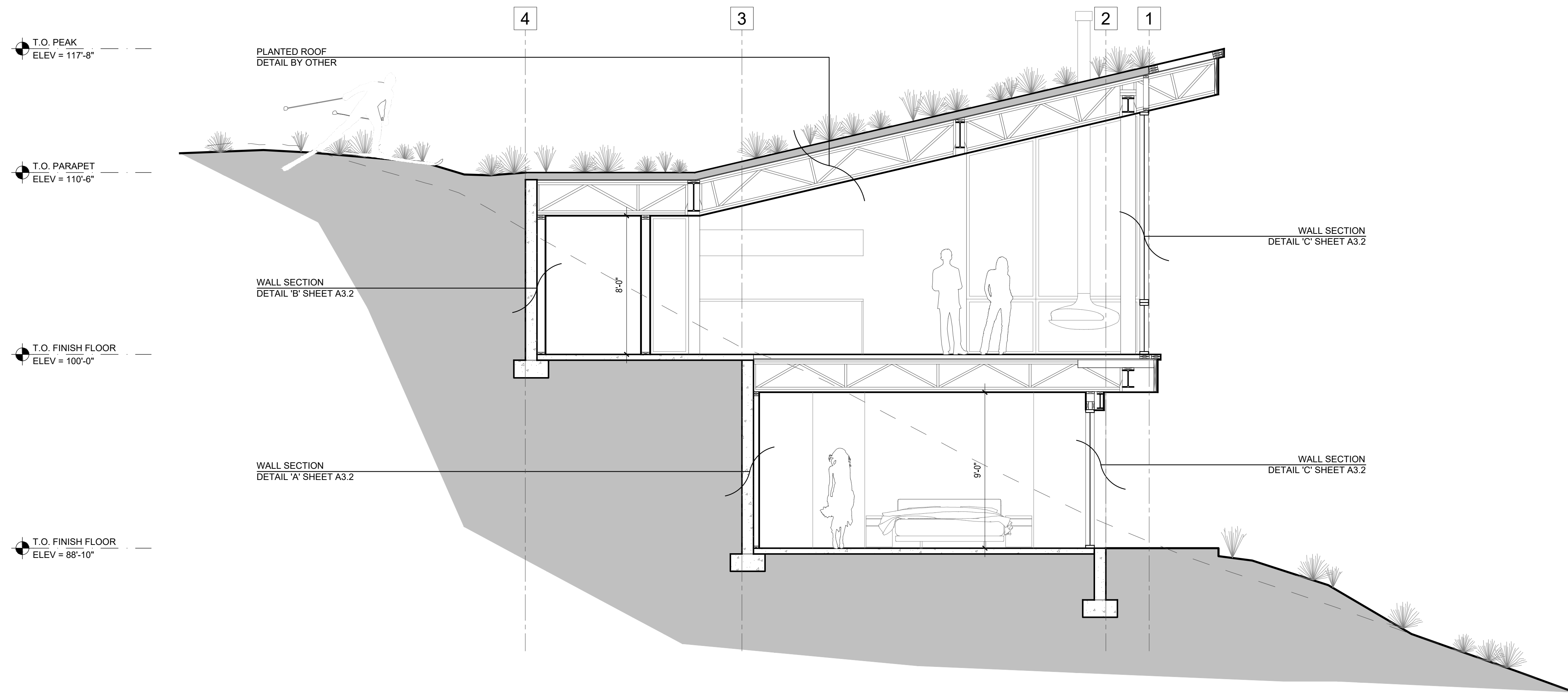

A Building Section
SCALE 1/4" = 1'-0"

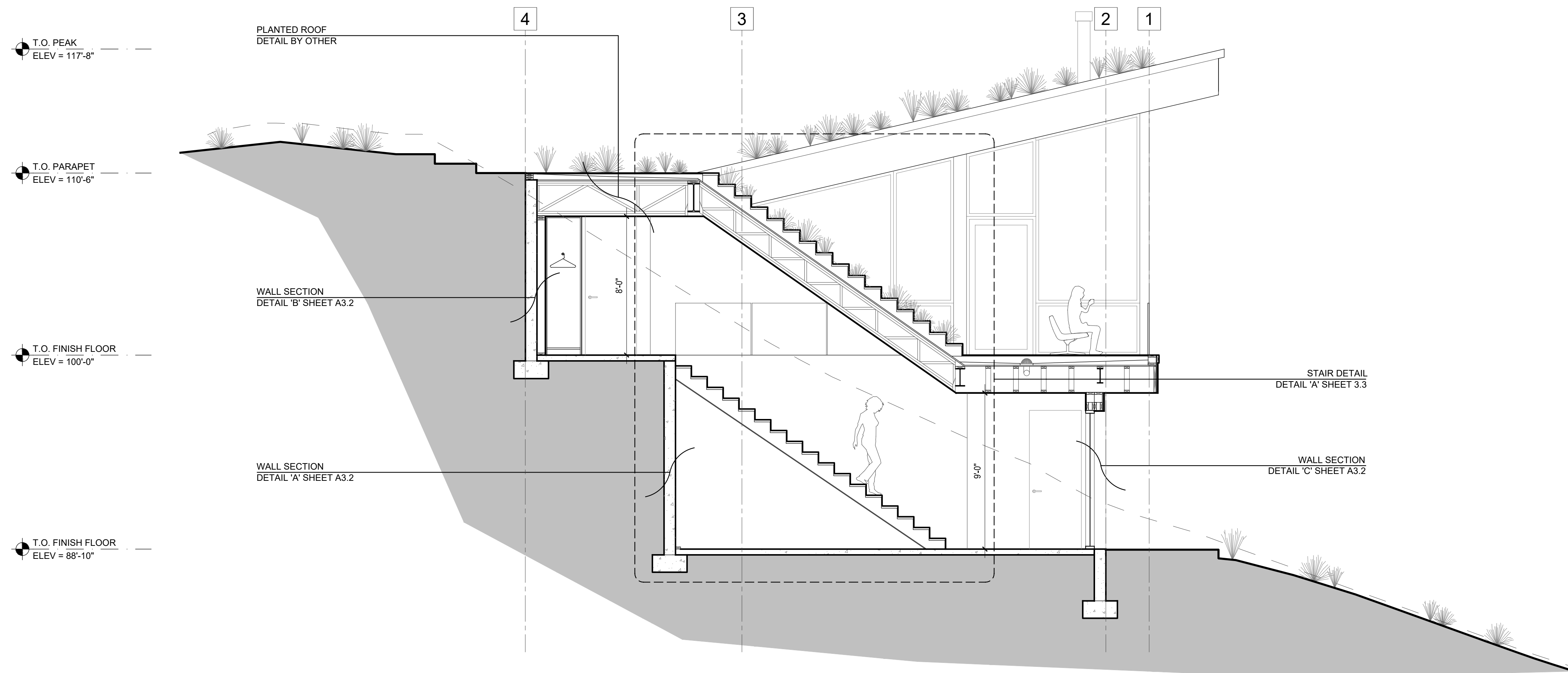

B Building Section
SCALE 1/4" = 1'-0"

PLAN REVIEW ACCEPTANCE
FOR COMPLIANCE WITH THE APPLICABLE CONSTRUCTION CODES IDENTIFIED BELOW.

<input checked="" type="checkbox"/> BUILDING	<input checked="" type="checkbox"/> STRUCTURAL
<input checked="" type="checkbox"/> MECHANICAL	<input checked="" type="checkbox"/> PLUMBING
<input checked="" type="checkbox"/> ELECTRICAL	<input checked="" type="checkbox"/> ENERGY
<input type="checkbox"/> ACCESSIBILITY	<input type="checkbox"/> FIRE

PLAN REVIEW ACCEPTANCE OF DOCUMENTS DOES NOT AUTHORIZE CONSTRUCTION TO PROCEED IN VIOLATION OF ANY FEDERAL, STATE, OR LOCAL REGULATIONS.

MEM 09/12/18
WEST COAST CODE CONSULTANTS, INC.

THESE PLANS ARE THE INTELLECTUAL PROPERTY OF IMBUE DESIGN, LLC AND ARE PROTECTED BY COMMON LAW, STATUTORY AND OTHER RESERVED RIGHTS INCLUDING, BUT NOT LIMITED TO, COPYRIGHT. THESE DRAWINGS MAY NOT BE REPRODUCED OR USED FOR ANY PURPOSE WITHOUT THE EXPLICIT WRITTEN CONSENT OF IMBUE DESIGN, LLC.

801.477.4174
 949 Denver Street
 SLC, Utah 84111
 imbue design
 ridge nest 14
 Ridge Nest 14 at Summit
 Eden, Utah 84310
 A3.0 SECTIONS
 Revision 2
 Date: 03.23.18
 Construction Documents

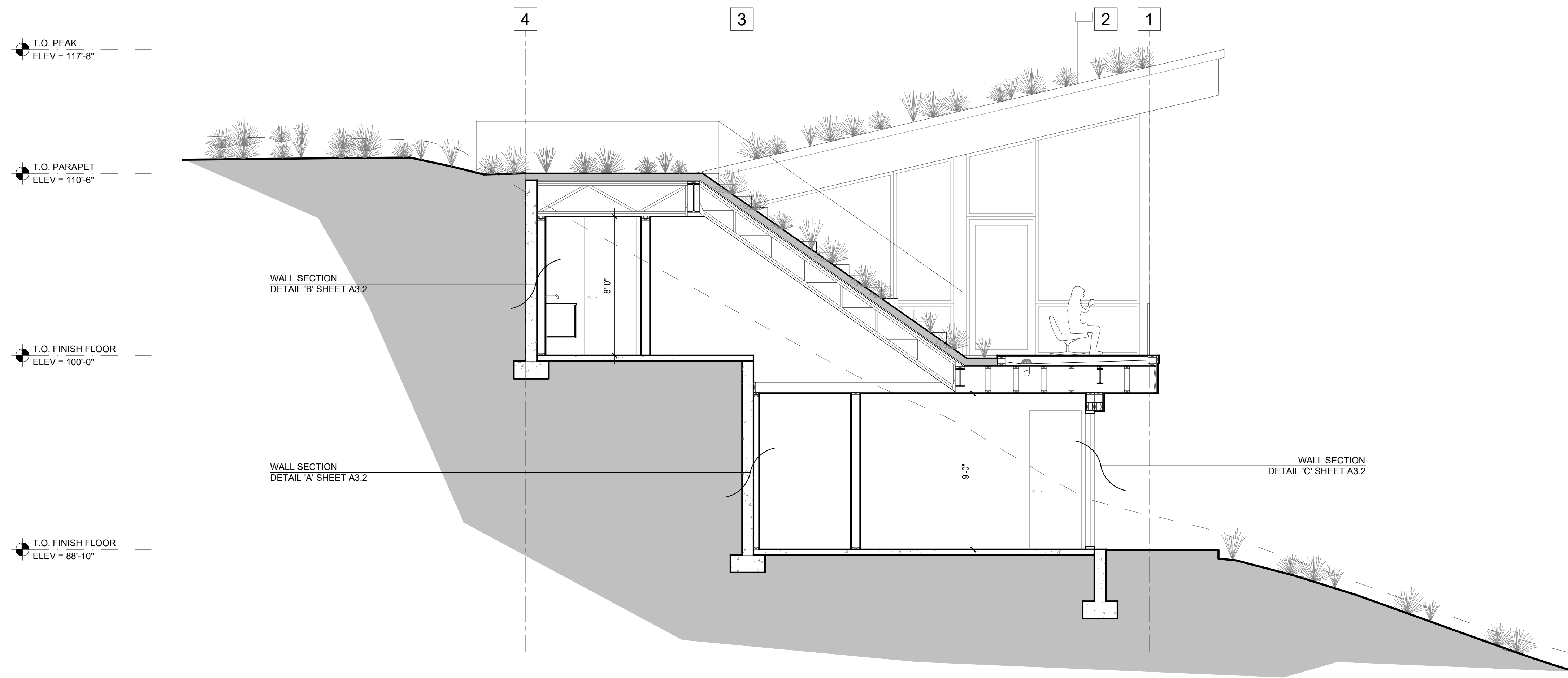

A Building Section
SCALE 1/4" = 1'-0"

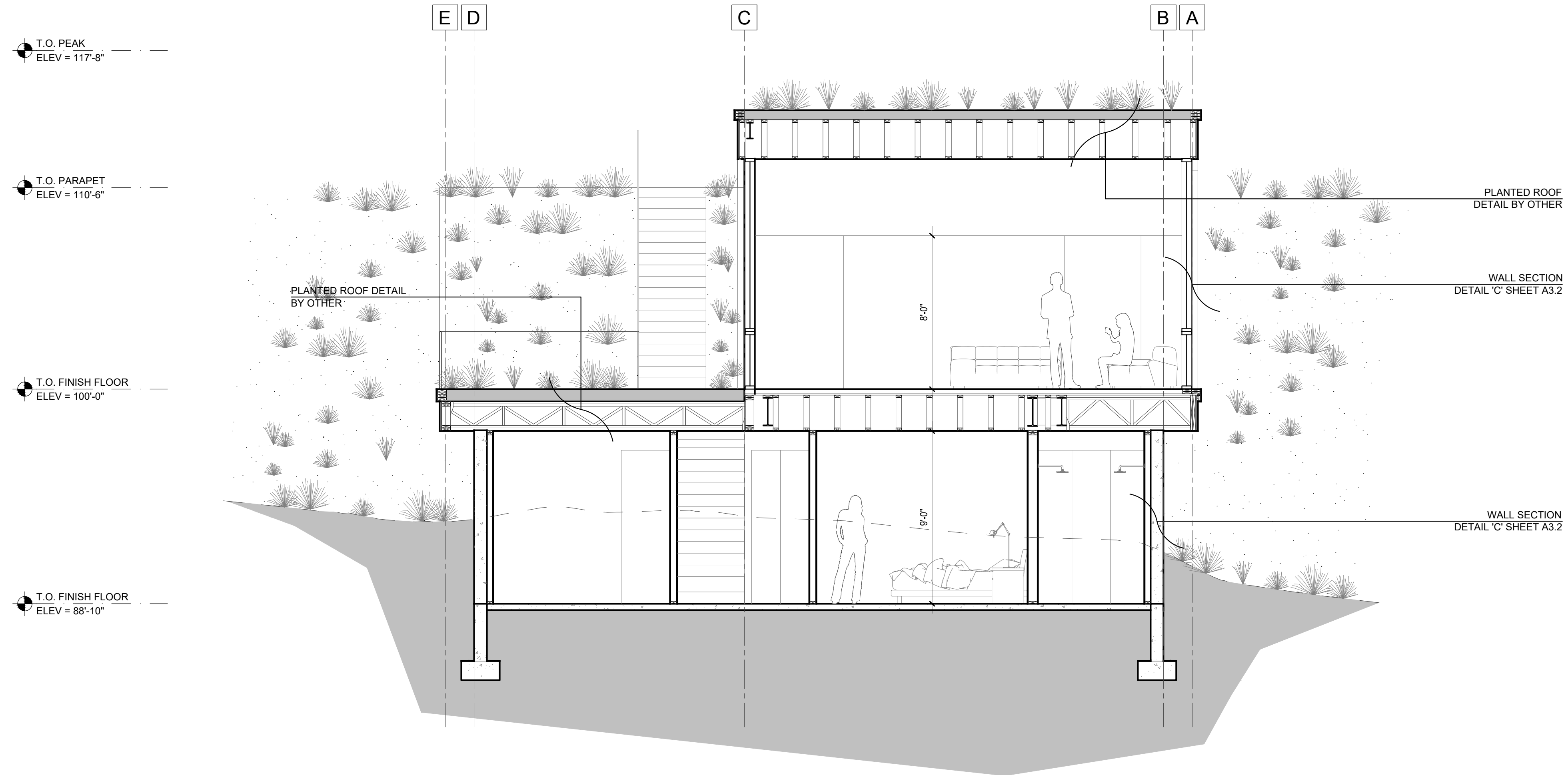

B Building Section
SCALE 1/4" = 1'-0"

PLAN REVIEW ACCEPTANCE
FOR COMPLIANCE WITH THE APPLICABLE CONSTRUCTION CODES IDENTIFIED BELOW.

<input checked="" type="checkbox"/> BUILDING	<input checked="" type="checkbox"/> STRUCTURAL
<input checked="" type="checkbox"/> MECHANICAL	<input checked="" type="checkbox"/> PLUMBING
<input checked="" type="checkbox"/> ELECTRICAL	<input checked="" type="checkbox"/> ENERGY
<input type="checkbox"/> ACCESSIBILITY	<input type="checkbox"/> FIRE

PLAN REVIEW ACCEPTANCE OF DOCUMENTS DOES NOT AUTHORIZE CONSTRUCTION TO PROCEED IN VIOLATION OF ANY FEDERAL, STATE, OR LOCAL REGULATIONS.

MEM 09/12/18
WEST COAST CODE CONSULTANTS, INC.

THESE PLANS ARE THE INTELLECTUAL PROPERTY OF IMBUE DESIGN, LLC AND ARE PROTECTED BY COMMON LAW, STATUTORY AND OTHER RESERVED RIGHTS INCLUDING, BUT NOT LIMITED TO, COPYRIGHT. THESE DRAWINGS MAY NOT BE REPRODUCED OR USED FOR ANY PURPOSE WITHOUT THE EXPLICIT WRITTEN CONSENT OF IMBUE DESIGN, LLC.

801.477.4174
949 Denver Street
SLC, Utah 84111

imbue design

A3.1
SECTIONS

Revision 2
Date: 03.23.18
Construction Documents

Ridge Nest 14 at Summit
Eden, Utah 84310
ridge nest 14

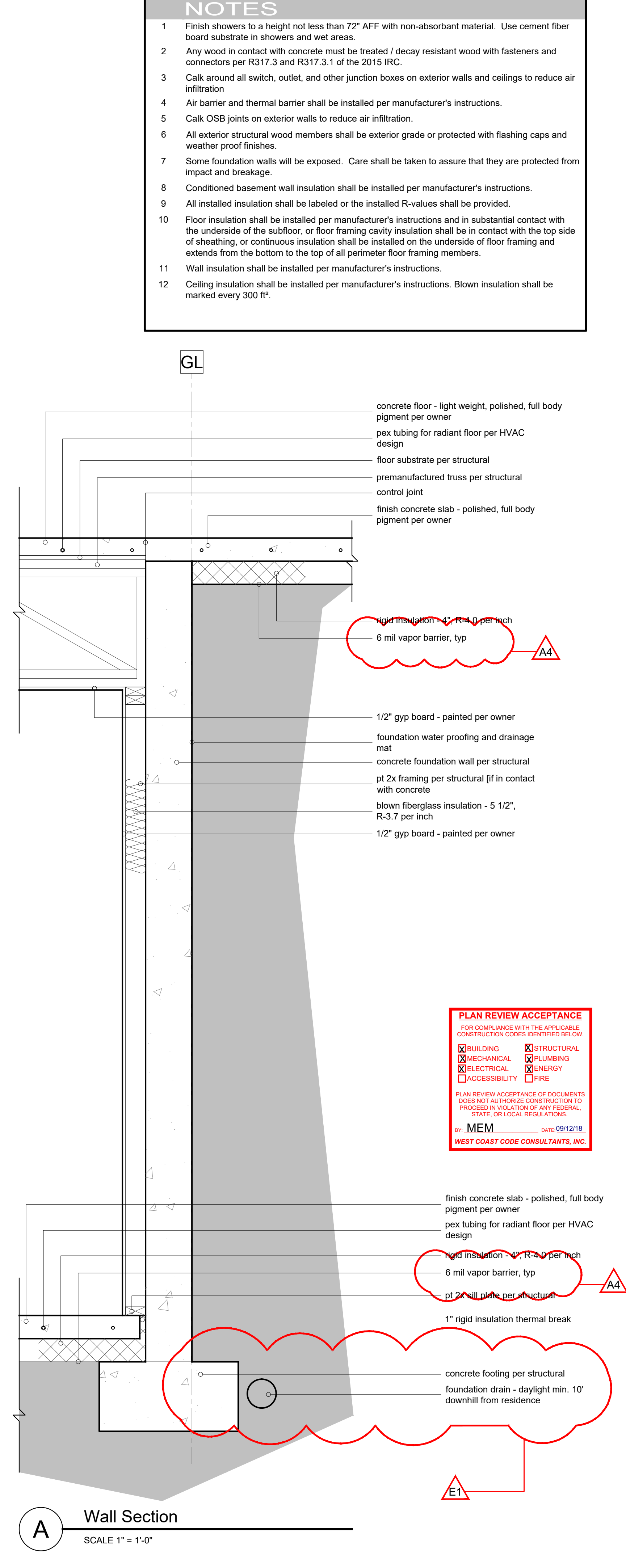
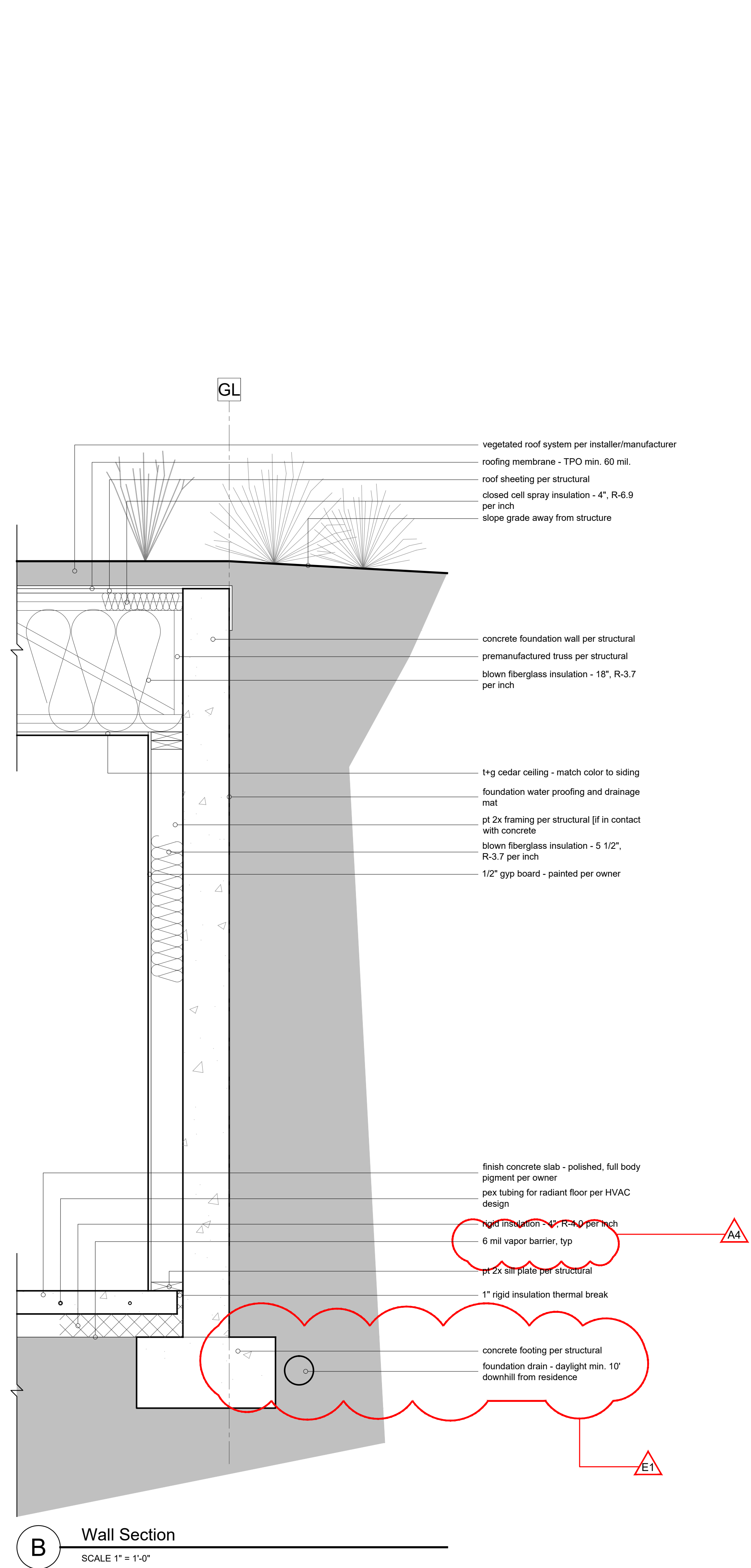
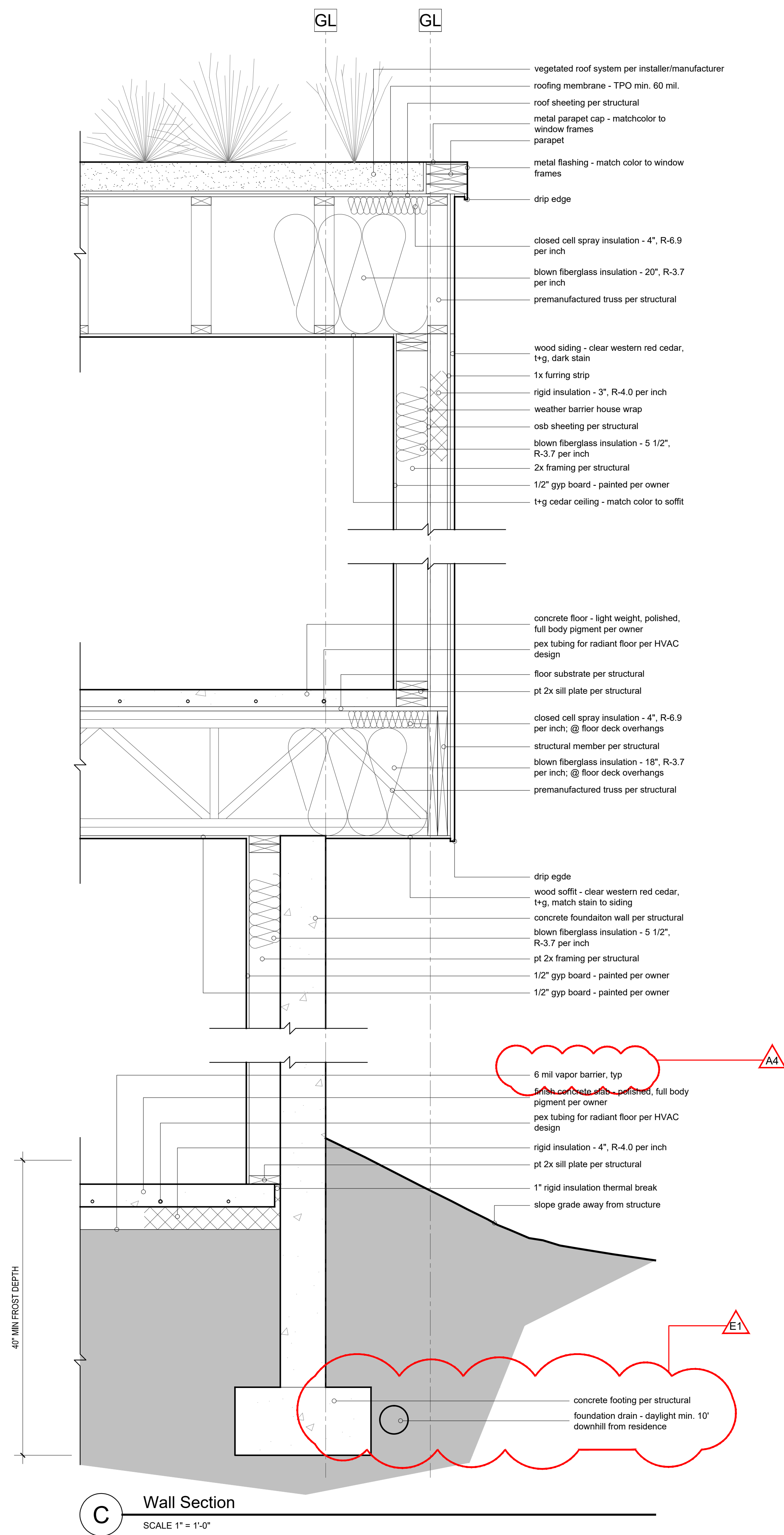

- NOTES**
- 1 Finish showers to a height not less than 72" AFF with non-absorbant material. Use cement fiber board substrate in showers and wet areas.
 - 2 Any wood in contact with concrete must be treated / decay resistant wood with fasteners and connectors per R317.3 and R317.3.1 of the 2015 IRC.
 - 3 Calk around all switch, outlet, and other junction boxes on exterior walls and ceilings to reduce air infiltration
 - 4 Air barrier and thermal barrier shall be installed per manufacturer's instructions.
 - 5 Calk OSB joints on exterior walls to reduce air infiltration.
 - 6 All exterior structural wood members shall be exterior grade or protected with flashing caps and weather proof finishes.
 - 7 Some foundation walls will be exposed. Care shall be taken to assure that they are protected from impact and breakage.
 - 8 Conditioned basement wall insulation shall be installed per manufacturer's instructions.
 - 9 All installed insulation shall be labeled or the installed R-values shall be provided.
 - 10 Floor insulation shall be installed per manufacturer's instructions and in substantial contact with the underside of the subfloor, or floor framing cavity insulation shall be in contact with the top side of sheathing, or continuous insulation shall be installed on the underside of floor framing and extends from the bottom to the top of all perimeter floor framing members.
 - 11 Wall insulation shall be installed per manufacturer's instructions.
 - 12 Ceiling insulation shall be installed per manufacturer's instructions. Blown insulation shall be marked every 300 ft².

PLAN REVIEW ACCEPTANCE
FOR COMPLIANCE WITH THE APPLICABLE CONSTRUCTION CODES IDENTIFIED BELOW:

<input checked="" type="checkbox"/> BUILDING	<input checked="" type="checkbox"/> STRUCTURAL
<input checked="" type="checkbox"/> MECHANICAL	<input checked="" type="checkbox"/> PLUMBING
<input checked="" type="checkbox"/> ELECTRICAL	<input checked="" type="checkbox"/> ENERGY
<input type="checkbox"/> ACCESSIBILITY	<input type="checkbox"/> FIRE

PLAN REVIEW ACCEPTANCE OF DOCUMENTS DOES NOT AUTHORIZE CONSTRUCTION TO PROCEED IN VIOLATION OF ANY FEDERAL, STATE, OR LOCAL REGULATIONS.

BY: **MEM** DATE: 09/12/18
WEST COAST CODE CONSULTANTS, INC.

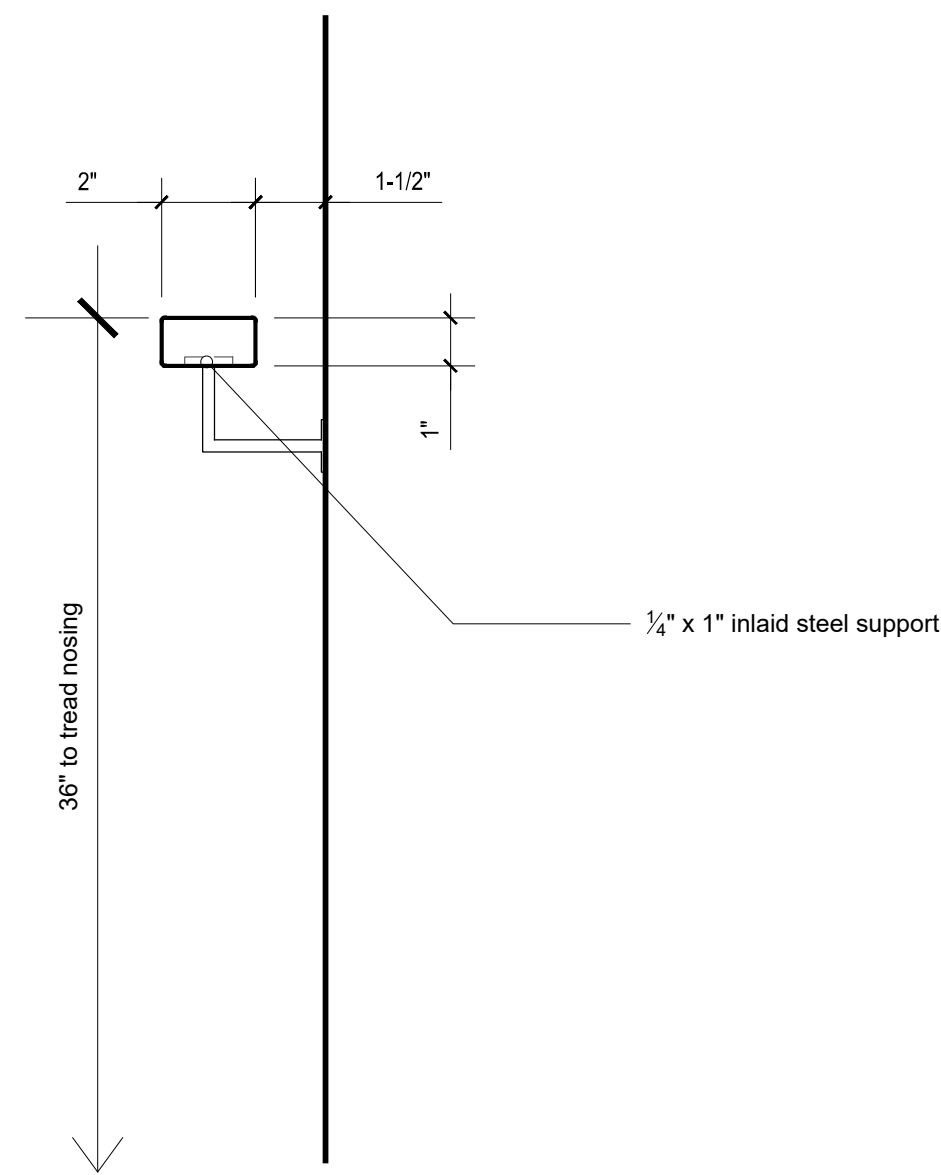

B Handrail Detail
SCALE 3" = 1'-0"

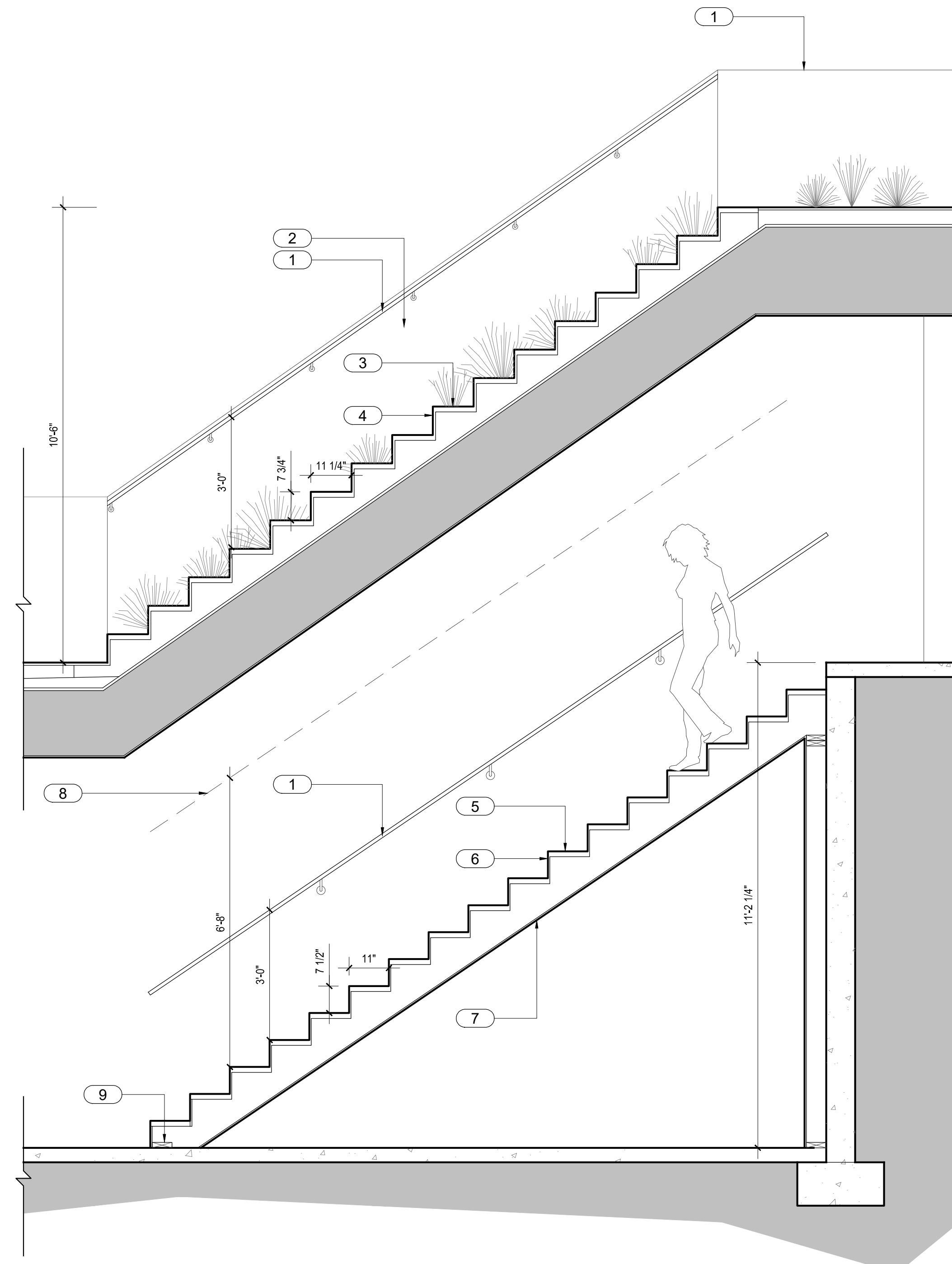

A Stair Detail
SCALE 1" = 1'-0"

#	KEYED NOTES
1	Handrail per B7A5.3
2	Glass guardrail - min 36" in height from nose of tread, glazing shall be min. 1/2" tempered safety glass
3	Ipe wood tread [exterior stairs]
4	Ipe wood riser [exterior stairs]
5	Wood tread per owner [interior stairs]
6	Wood riser per owner [interior stairs]
7	1/2" gyp board
8	Minimum head clearance at stairs
9	PT nailer - glue and mechanically fasten to concrete slab

NOTES	
1	Handrail construction must comply with section R311 of the IRC. Return handrail terminations into the wall.
2	Match wood handrail to corresponding stair treads

PLAN REVIEW ACCEPTANCE
FOR COMPLIANCE WITH THE APPLICABLE CONSTRUCTION CODES IDENTIFIED BELOW.

<input checked="" type="checkbox"/> BUILDING	<input checked="" type="checkbox"/> STRUCTURAL
<input checked="" type="checkbox"/> MECHANICAL	<input checked="" type="checkbox"/> PLUMBING
<input checked="" type="checkbox"/> ELECTRICAL	<input checked="" type="checkbox"/> ENERGY
<input type="checkbox"/> ACCESSIBILITY	<input type="checkbox"/> FIRE

PLAN REVIEW ACCEPTANCE OF DOCUMENTS DOES NOT AUTHORIZE CONSTRUCTION TO PROCEED IN VIOLATION OF ANY FEDERAL, STATE, OR LOCAL REGULATIONS.

BY: **MEM** DATE: 09/12/18
WEST COAST CODE CONSULTANTS, INC.

THESE PLANS ARE THE INTELLECTUAL PROPERTY OF IMBUE DESIGN, LLC AND ARE PROTECTED BY COMMON LAW, STATUTORY AND OTHER RESERVED RIGHTS INCLUDING, BUT NOT LIMITED TO, COPYRIGHT. THESE DRAWINGS MAY NOT BE REPRODUCED OR USED FOR ANY PURPOSE WITHOUT THE EXPLICIT WRITTEN CONSENT OF IMBUE DESIGN, LLC.

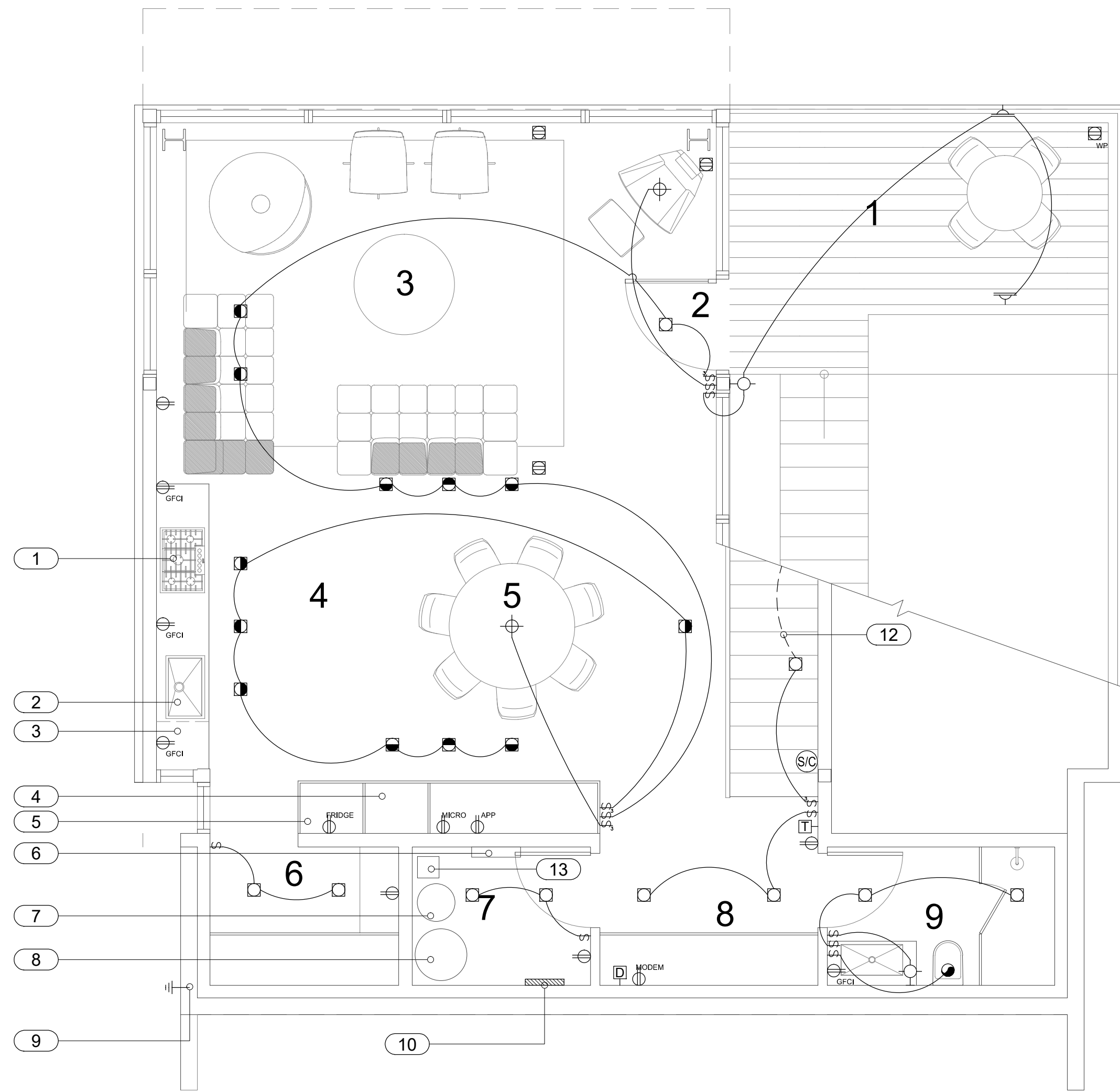

B Upper Floor Electrical Plan
 SCALE 1/4" = 1'-0"
 895 SQ FT
 TOTAL 1,586 SQ FT

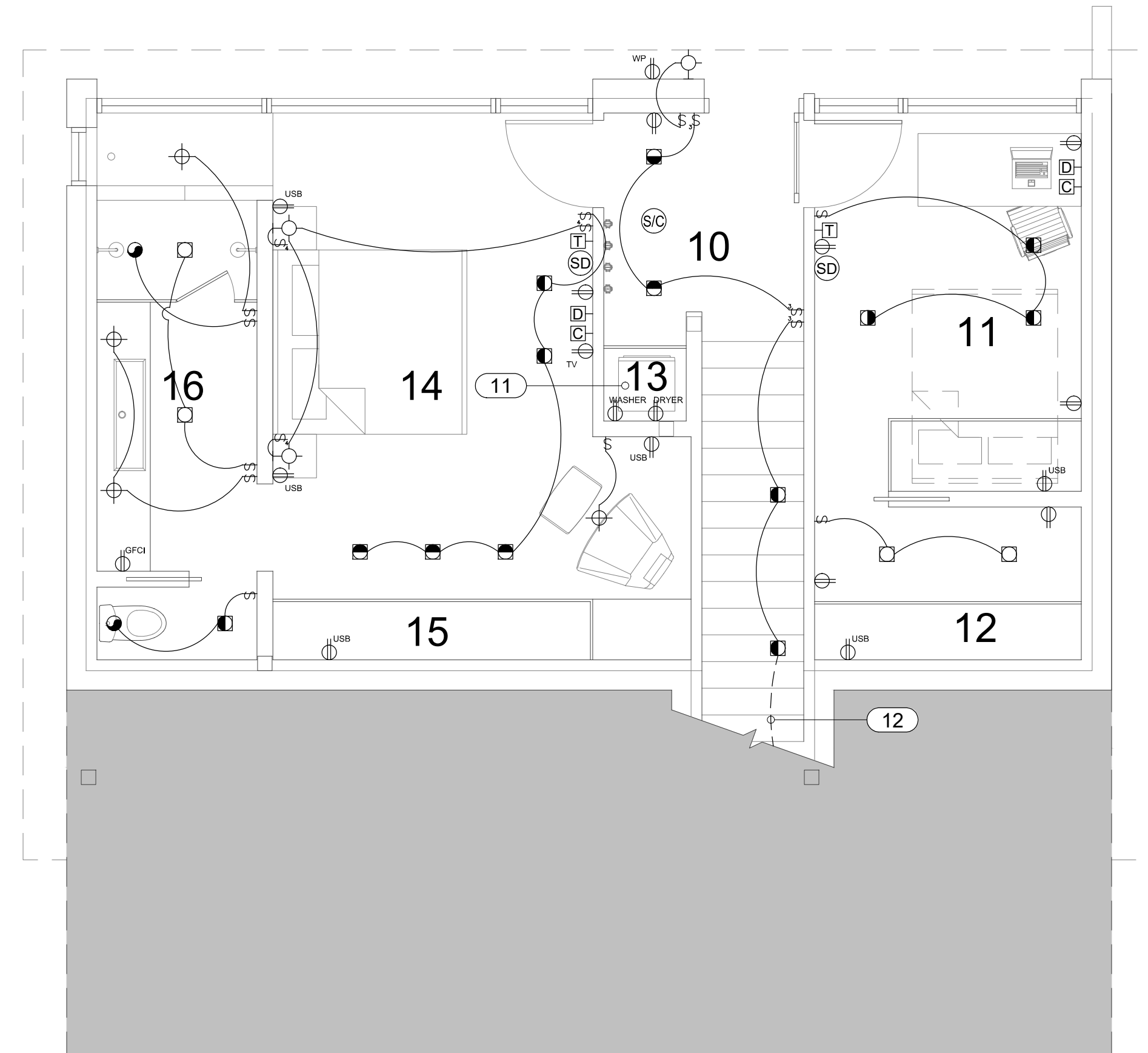

A Lower Floor Electrical Plan
 SCALE 1/4" = 1'-0"
 701 SQ FT
 TOTAL 1,586 SQ FT

LEGEND

	Circuit home run - indicates panel and circuit numbers
	Conduit to below, in slab or below grade
	Conduit up
(E)	Existing
	Thermostat
	Junction box
	TV cable jack, up 12" or as indicated
	Data
	Wall mounted telephone outlet, up 44", 6" above counter, or as indicated.

	Recessed can light fixture
	Directional recessed can light fixture
	Wall mount light fixture
	Ceiling mount light fixture
	Pendant light fixture
	Recessed exhaust fan with light
	Recessed exhaust fan
	Motor
	Door bell
	Heat detectors w/ battery backup (wired in series)

	Smoke detectors w/ battery backup (wired in series)
	Smoke / carbon monoxide detectors w/ battery backup
	Carbon monoxide detector w/ battery backup
	Building mass notification speaker (existing)
	Special purpose dedicated circuit, coordinate power as required
	Recessed path light
	220 circuit, coordinate with owner's requirements
	20 amp ground fault circuit interrupter duplex receptacle, 12" AFF to center, UNO
	20 amp in floor duplex receptacle, brass plate w/ flip lids
	20 amp duplex receptacle, top half switched, 12" AFF to center, UNO

	20 amp duplex receptacle, 12" AFF to center, UNO
	20 amp ground fault circuit interrupter with weatherproof housing, 12" AFF to center, UNO
	Single pole wall switch, 44" AFF to center, UNO
	Three way wall switch, 44" AFF to center, UNO
	Four way wall switch, 44" AFF to center, UNO
	Dimmer wall switch, 44" AFF to center, UNO
	Accent lighting (low voltage MR-16 bulb)
	Low voltage under / above cabinet lighting
	Low voltage transformer
	Ground

ROOM DESCRIPTIONS

- 1 Viewing Deck
- 2 Entry
- 3 Living
- 4 Kitchen
- 5 Dining
- 6 Pantry
- 7 Mechanical
- 8 Closet
- 9 Powder Room
- 10 Mudroom
- 11 Office/Bedroom
- 12 Closet
- 13 Laundry
- 14 Master Bedroom
- 15 Master Closet
- 16 Master Bathroom

NOTES

- 1 GC shall assess and field verify all dimensions and conditions prior to doing any work.
- 2 All work to be performed by a licensed electrical contractor. The work shall be consistent with the best practices of the trade and in compliance with the IBC / IRC & nat. electric code.
- 3 Work and materials shall be in accordance with the 2014 NEC unless more stringent requirements are called out in drawing or specifications.
- 4 GFCI protection of outlets is required in bathrooms, kitchens, garages, outdoors with direct grade level access, including decks and balconies, crawl spaces with outlets, and in unfinished basements.
- 5 Lighting outlets shall be on a #14 or #12 wire circuit with a maximum of 12 outlets. All convenience outlets shall be on a #12 wire circuit fused at 20 amps. No more than 8 outlets permitted on any circuit serving convenience outlets.
- 6 Provide temporary construction power as required; coordinate with other contractors for requirements.
- 7 Field coordinate and verify installation requirements and locations with other disciplines. Assure proper clearances are maintained. Field verify electrical requirements of equipment furnished by others for fuse or circuit breaker, disconnect, conductor sizes and receptacles. (Do not reduce wire sizes indicated on the drawings).
- 8 Coordinate with mechanical contractor for installation of conduit, boxes and other contractors and owner.
- 9 All conductors to be copper with THWN or XHHW insulation unless otherwise noted. Conductors to be size #12 AWG in type NM cable UNO.
- 10 Any conduit installed in the building interior shall be EMT and any conduit installed on the exterior of the building shall be IMC unless otherwise noted. Size to be 1/2" UNO. All conduit underground or under slab shall be schedule 40 PVC with tape wrapped GRC swept elbow risers, 3/4" inch UNO.
- 11 Exposed conduit shall be run parallel or perpendicular to building lines.
- 12 Owner shall approve heat tape & seasonal lighting locations.
- 13 Electrical contractor shall perform a "walk-through" with Owner and Architect / Designer prior to installation.
- 14 Provide arc-fault circuit interruption protection on all bedroom circuits.
- 15 Electrical panels shall comply with section E3405 of the 2015 IRC. Provide min. clearance of 30" width by 6'-6" height and 36" in depth off wall for panel area.
- 16 Electrician shall advise on proper fluorescent ballast in cooler areas and on LED dimming compatibilities.
- 17 Install gas fireplace, furnace, water heater, all gas appliances, and gas equipment to manufactures specs and to meet Section M1401.1 of the 2015 IRC. Consult with Owners to verify any special equipment or conditions.
- 18 Smoke, heat and carbon monoxide alarms shall be installed hardwired/interconnected with battery backup and in accordance with NFPA 72 and section R314 of the 2015 IRC.
- 19 All recessed cans at building envelope shall be IC rated, air tight and labeled to indicated < or = to 2.0 cfm leakage at 75 Pa.
- 20 Kitchen countertop GFCI receptacles shall be distributed in accordance with section E3901.4 of the 2015 IRC.
- 21 Tamper resistant receptacles shall be required for all 15 and 20 amp receptacles per section 406.12 of the 2014 NEC.
- 22 Light fixtures in closets: Surface mounted incandescent fixtures to have 12" min. between the fixture and any storage. Surface mounted fluorescent fixtures to have 6" min. between fixture and any storage in accordance to section E4003.12 of the 2015 IRC.
- 23 Receptacles in damp and wet locations: Exterior outlets shall be equipped with weatherproof covers and shall be listed for wet or damp locations in accordance to section E3905.11 of the 2015 IRC.
- 24 Small appliance receptacles: A minimum of two (2) 20 amp circuits shall serve all wall and floor outlets of the kitchen in accordance to section E3901.3 of the 2015 IRC.
- 25 All exterior lighting shall be Dark Skies Compliant.
- 26 A permanent certificate shall be posted on or in the electrical distribution panel listing the predominant R-values of insulation installed in or on ceiling/roof, walls, foundation, (slab, basement wall, crawlspace wall and/or floor) and ducts outside the conditioned spaces; U-factors of windows, and the solar heat gain coefficients of windows. The type and efficiency of heating and cooling and service water heating equipment shall also be listed. Note: The panel and cover shall not be modified in any way.
- 27 Electrical load calculations and service loads calculated in accordance with table e3602.2 or article 220nec. Project load calculations attached to document set.

KEYED NOTES

- 1 Induction cooktop per spec sheet
- 2 Disposal - switch in cabinet under sink
- 3 Integrated dishwasher per spec sheet
- 4 Oven per spec sheet
- 5 Integrated fridge-freezer per spec sheet
- 6 Radiant heat manifold
- 7 Boiler for radiant heat system
- 8 Water heater for domestic hot water
- 9 UFER ground
- 10 Electrical panel - 200 amp
- 11 Stackable washer + dryer per spec sheet
- 12 Line to three way switch on other level
- 13 HRV - must supply >3 air changes per hour per IRC R303.4

PLAN REVIEW ACCEPTANCE
 FOR COMPLIANCE WITH THE APPLICABLE CONSTRUCTION CODES IDENTIFIED BELOW:

<input checked="" type="checkbox"/> BUILDING	<input checked="" type="checkbox"/> STRUCTURAL
<input checked="" type="checkbox"/> MECHANICAL	<input checked="" type="checkbox"/> PLUMBING
<input checked="" type="checkbox"/> ELECTRICAL	<input checked="" type="checkbox"/> ENERGY
<input checked="" type="checkbox"/> ACCESSIBILITY	<input checked="" type="checkbox"/> FIRE

PLAN REVIEW ACCEPTANCE OF DOCUMENTS DOES NOT AUTHORIZE CONSTRUCTION TO PROCEED IN VIOLATION OF ANY FEDERAL, STATE, OR LOCAL REGULATIONS.

MEM 09/12/18
 WEST COAST CODE CONSULTANTS, INC.

THESE PLANS ARE THE INTELLECTUAL PROPERTY OF IMBUE DESIGN, LLC AND ARE PROTECTED BY COMMON LAW, STATUTORY AND OTHER RESERVED RIGHTS INCLUDING, BUT NOT LIMITED TO, COPYRIGHT. THESE DRAWINGS MAY NOT BE REPRODUCED OR USED FOR ANY PURPOSE WITHOUT THE EXPLICIT WRITTEN CONSENT OF IMBUE DESIGN, LLC.

801.477.4174
 949 Denver Street
 SLC, Utah 84111
 design ridge nest 14
 imbue
 E1.0 ELECTRICAL PLANS
 Revision 2
 Date: 09/23/18
 Construction Documents

ROOM DESCRIPTIONS

- 1 Viewing Deck
- 2 Entry
- 3 Living
- 4 Kitchen
- 5 Dining
- 6 Pantry
- 7 Mechanical
- 8 Closet
- 9 Powder Room
- 10 Mudroom
- 11 Office/Bedroom
- 12 Closet
- 13 Laundry
- 14 Master Bedroom
- 15 Master Closet
- 16 Master Bathroom

NOTES

- 1 GC shall assess and field verify all dimensions and conditions prior to doing any work.
- 2 All work to be performed by a licensed electrical contractor. The work shall be consistent with the best practices of the trade and in compliance with the IBC / IRC & nat. electric code.
- 3 Work and materials shall be in accordance with the 2014 NEC unless more stringent requirements are called out in drawing or specifications.
- 4 GFCI protection of outlets is required in bathrooms, kitchens, garages, outdoors with direct grade level access, including decks and balconies, crawl spaces with outlets, and in unfinished basements.
- 5 Lighting outlets shall be on a #14 or #12 wire circuit with a maximum of 12 outlets. All convenience outlets shall be on a #12 wire circuit fused at 20 amps. No more than 8 outlets permitted on any circuit serving convenience outlets.
- 6 Provide temporary construction power as required, coordinate with other contractors for requirements.
- 7 Field coordinate and verify installation requirements and locations with other disciplines. Assure proper clearances are maintained. Field verify electrical requirements of equipment furnished by others for fuse or circuit breaker, disconnect, conductor sizes and receptacles. (Do not reduce wire sizes indicated on the drawings)
- 8 Coordinate with mechanical contractor for installation of conduit, boxes and other contractors and owner.
- 9 All conductors to be copper with THWN or XHHW insulation unless otherwise noted. Conductors to be size #12 AWG in type NM cable UNO.
- 10 Any conduit installed in the building interior shall be EMT and any conduit installed on the exterior of the building shall be IMC unless otherwise noted. Size to be 1/2" UNO. All conduit underground or under slab shall be schedule 40 PVC with tape wrapped GRC swept elbow risers, 3/4" inch UNO.
- 11 Exposed conduit shall be run parallel or perpendicular to building lines.
- 12 Owner shall approve heat tape & seasonal lighting locations.
- 13 Electrical contractor shall perform a "walk-through" with Owner and Architect / Designer prior to installation.
- 14 Provide arc-fault circuit interruption protection on all bedroom circuits.
- 15 Electrical panels shall comply with section E3405 of the 2015 IRC. Provide min. clearance of 30" width by 6'-6" height and 36" in depth off wall for panel area.
- 16 Electrician shall advise on proper fluorescent ballast in cooler areas and on LED dimming compatibilities.
- 17 Install gas fireplace, furnace, water heater, all gas appliances, and gas equipment to manufactures specs and to meet Section M1401.1 of the 2015 IRC. Consult with Owners to verify any special equipment or conditions.
- 18 Smoke, heat and carbon monoxide alarms shall be installed hardwired/interconnected with battery backup and in accordance with NFPA 72 and section R314 of the 2015 IRC.
- 19 All recessed cans at building envelope shall be IC rated, air tight and labeled to indicated < or = to 2.0 cfm leakage at 75 Pa.
- 20 Kitchen countertop GFCI receptacles shall be distributed in accordance with section E3901.4 of the 2015 IRC.
- 21 Tamper resistant receptacles shall be required for all 15 and 20 amp receptacles per section 406.12 of the 2014 NEC.
- 22 Light fixtures in closets : Surface mounted incandescent fixtures to have 12" min. between the fixture and any storage. Surface mounted fluorescent fixtures to have 6" min. between fixture and any storage in accordance to section E4003.12 of the 2015 IRC.
- 23 Receptacles in damp and wet locations : Exterior outlets shall be equipped with weatherproof covers and shall be listed for wet or damp locations in accordance to section E3905.11 of the 2015 IRC.
- 24 Small appliance receptacles : A minimum of two (2) 20 amp circuits shall serve all wall and floor outlets of the kitchen in accordance to section E3901.3 of the 2015 IRC.
- 25 All exterior lighting shall be Dark Skies Compliant.
- 26 A permanent certificate shall be posted on or in the electrical distribution panel listing the predominant R-values of insulation installed in or on ceiling/roof, walls, foundation, (slab, basement wall, crawlspace wall and/or floor) and ducts outside the conditioned spaces; U-factors of windows, and the solar heat gain coefficients of windows. The type and efficiency of heating and cooling and service water heating equipment shall also be listed. Note: The panel and cover shall not be modified in any way.
- 27 Electrical load calculations and service loads calculated in accordance with table e3602.2 or article 220nec. Project load calculations attached to document set.

KEYED NOTES

- 1 Switch with occupancy-photo electric sensor

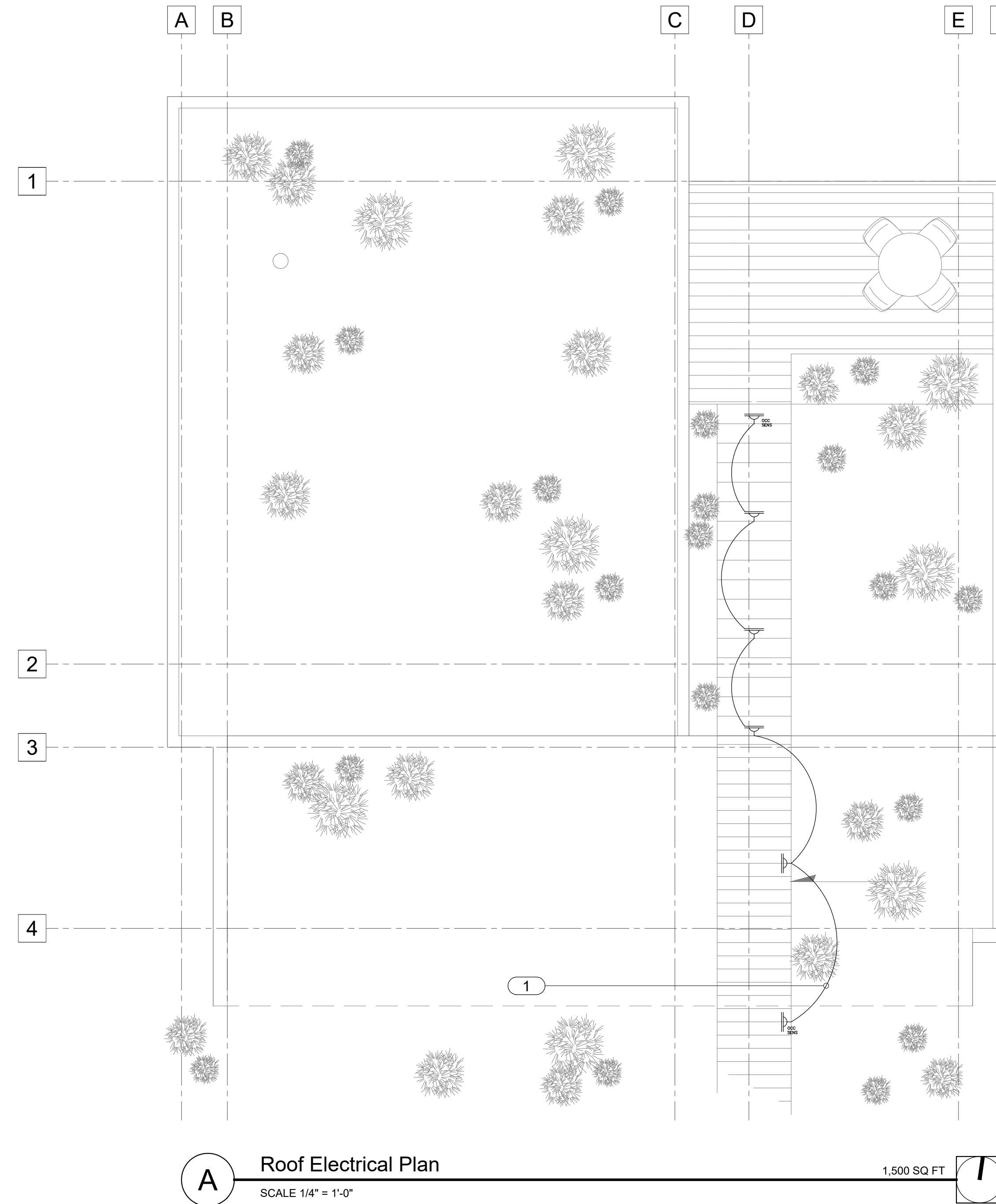

A Roof Electrical Plan
SCALE 1/4" = 1'-0"

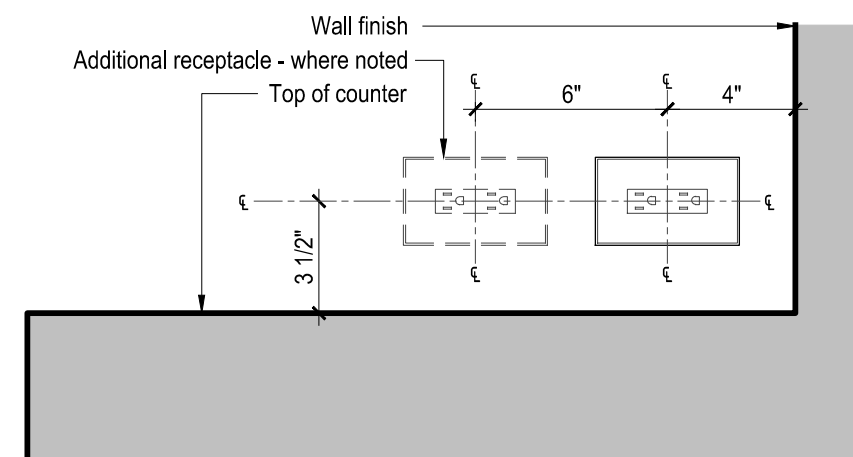

B Receptacle at Countertop
SCALE 2" = 1'-0"

LEGEND

	Circuit home run - indicates panel and circuit numbers		Recessed can light fixture		Smoke detectors w/ battery backup (wired in series)		20 amp duplex receptacle, 12" AFF to center, UNO
	Conduit to below, in slab or below grade		Directional recessed can light fixture		Smoke / carbon monoxide detectors w/ battery backup		20 amp ground fault circuit interrupter with weatherproof housing, 12" AFF to center, UNO
	Conduit up		Wall mount light fixture		Carbon monoxide detector w/ battery backup		Single pole wall switch, 44" AFF to center, UNO
	Existing		Ceiling mount light fixture		Building mass notification speaker (existing)		Three way wall switch, 44" AFF to center, UNO
	Thermostat		Pendant light fixture		Special purpose dedicated circuit, coordinate power as required		Four way wall switch, 44" AFF to center, UNO
	Junction box		Recessed exhaust fan with light		Recessed path light		Dimmer wall switch, 44" AFF to center, UNO
	TV cable jack, up 12" or as indicated		Recessed exhaust fan		220 circuit, coordinate with owner's requirements		Accent lighting (low voltage MR-16 bulb)
	Data		Motor		20 amp ground fault circuit interrupter duplex receptacle, 12" AFF to center, UNO		Low voltage under / above cabinet lighting
	Wall mounted telephone outlet, up 44", 6" above counter, or as indicated.		Door bell		20 amp in floor duplex receptacle, brass plate w/ flip lids		Low voltage transformer
			Heat detectors w/ battery backup (wired in series)		20 amp duplex receptacle, top half switched, 12" AFF to center, UNO		Ground

PLAN REVIEW ACCEPTANCE
FOR COMPLIANCE WITH THE APPLICABLE CONSTRUCTION CODES IDENTIFIED BELOW:

<input checked="" type="checkbox"/> BUILDING	<input checked="" type="checkbox"/> STRUCTURAL
<input checked="" type="checkbox"/> MECHANICAL	<input checked="" type="checkbox"/> PLUMBING
<input checked="" type="checkbox"/> ELECTRICAL	<input checked="" type="checkbox"/> ENERGY
<input checked="" type="checkbox"/> ACCESSIBILITY	<input checked="" type="checkbox"/> FIRE

PLAN REVIEW ACCEPTANCE OF DOCUMENTS DOES NOT AUTHORIZE CONSTRUCTION TO PROCEED IN VIOLATION OF ANY FEDERAL, STATE, OR LOCAL REGULATIONS.
MEM DATE: 09/12/18
WEST COAST CODE CONSULTANTS, INC.

THESE PLANS ARE THE INTELLECTUAL PROPERTY OF IMBUE DESIGN, LLC AND ARE PROTECTED BY COMMON LAW, STATUTORY AND OTHER RESERVED RIGHTS INCLUDING, BUT NOT LIMITED TO, COPYRIGHT. THESE DRAWINGS MAY NOT BE REPRODUCED OR USED FOR ANY PURPOSE WITHOUT THE EXPLICIT WRITTEN CONSENT OF IMBUE DESIGN, LLC.

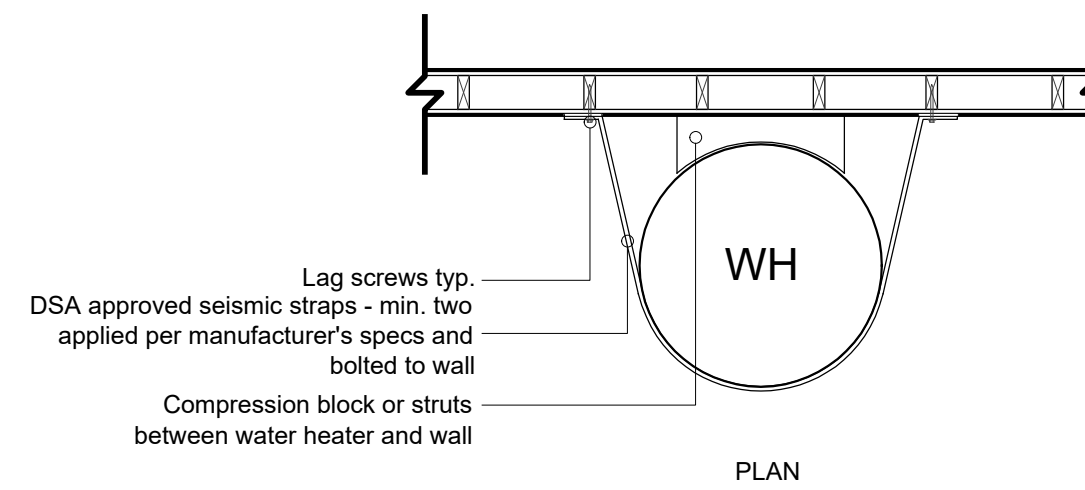

Note:
1. Water heater shall be anchored or strapped in the upper third and lower one-third of the appliance to resist horizontal force equal to one third of the operating weight per IRC P2801.7

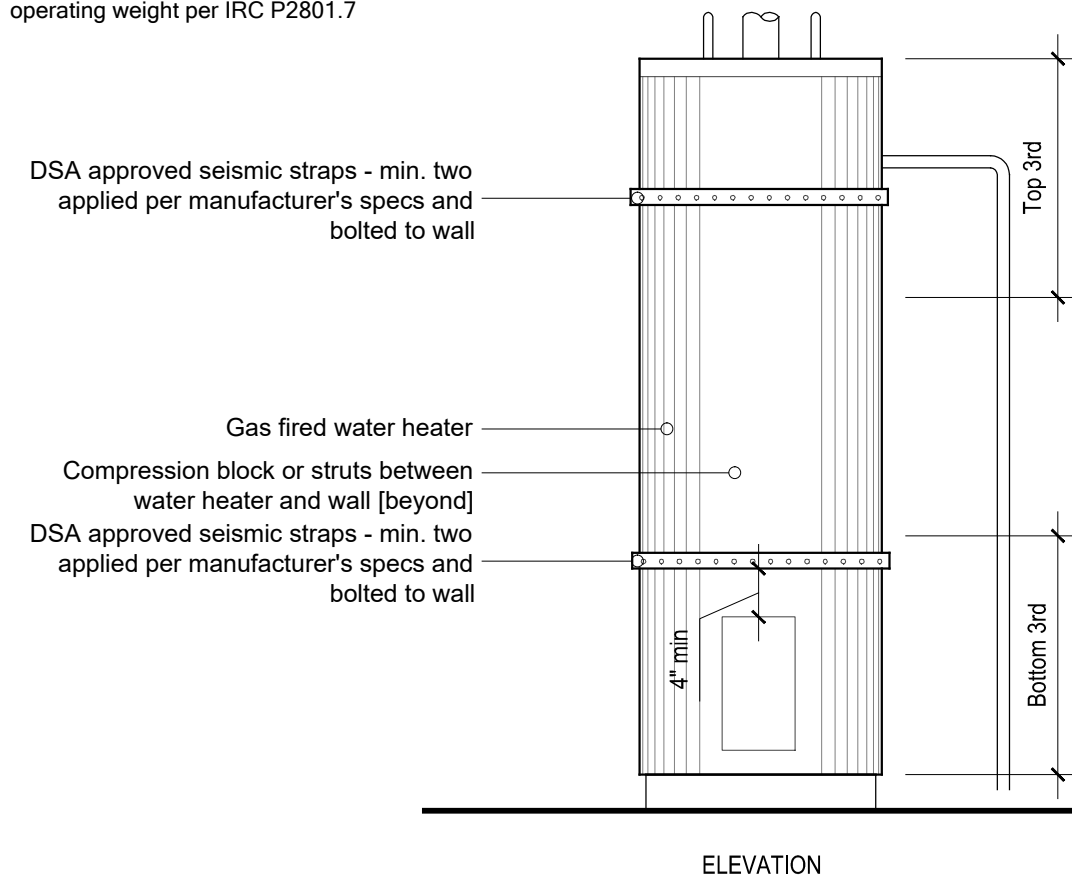

A Water Heater Seismic Anchoring
DO NOT SCALE

NOTES

- 1 All pipe distances, sizes and appliance BTU inputs shall be field verified and re-calculated, if necessary, in accordance with NFPA by the Contractor prior to final sizing and installation of gas lines.
- 2 These drawings are scope documents. Plumbing/Mechanical Contractor shall provide a complete, code-compliant system with all materials, labor, fittings and trim. Review drawings and notify the Designer immediately of areas of concern or conflict. Where Owner-supplied fixtures are noted, if any, contractor shall provide all necessary piping connections, including tail pieces and traps.
- 3 These drawings are diagrammatic only. The drawings are intended to indicate capacity, size location, direction and general arrangement, but not exact details of construction. Given that only certain features of the installation are indicated, Contractor shall not imply that other features will not be required.
- 4 Contractor shall coordinate with all other trades to ensure that each trade shall have sufficient space to install their equipment [ductwork, piping, electrical, plumbing, etc].
- 5 Contractor shall field verify the condition and space for the installation of work, making all necessary routing, fitting and connections as required for a complete system.
- 6 Contractor shall field verify all dimensions on the project drawings.
- 7 All rises and drops in piping are not necessarily shown.
- 8 Contractor shall provide all structural members, support brackets, flashing, hardware, etc, required to install a complete system.
- 9 Contractor shall provide access panels for all shut-off valves located in finish surfaces.
- 10 All plumbing work shall conform to applicable codes and regulations found in the 2015 IRC.
- 11 Contractor shall provide dielectric fitting and separation between two dissimilar metals.
- 12 Contractor shall collect all booklets, operation instructions, warranty information, parts, diagrams, etc, and provide them to the Owner at the completion of work.
- 13 Contractor shall coordinate all roof penetrations with the General Contractor.
- 14 Access shall be provided to all air-admittance valves. The valves shall be located within a ventilated space that allows air to enter the valve.
- 15 Any air admittance valves shall be rated in accordance with the standard size of the vent to which the valve is connected.
- 16 A minimum of one stack vent shall extend outdoors to the open air within the plumbing system.
- 17 Combustion air for all fuel-burning appliances shall be at a minimum rate of 1 square inch per 3,000 BTU per hour input and one opening shall be in the top 12 inches of the room, per section G2407 of the 2015 IRC.
- 18 Fuel-burning appliances in mechanical spaces shall have a minimum of 3 inch clearance around equipment at sides and rear of appliance, and 6 inch clearance in front of appliance. Total width of enclosed mechanical space shall be not less than 12 inches wider than the furnace or boiler.
- 19 Automatic or gravity dampers shall be installed on all outdoor air intakes and exhausts.
- 20 Wood-burning fireplaces shall have tight fitting flue dampers and outdoor air for combustion per IECC 402.4.2

FUEL GAS NOTES

- 1 PROJECT DATA Total building gas demand : 368,000 BTU's / 420 CFH
Longest pipe run : 110 feet
- 2 DESIGN DATA Inlet Pressure : < 2 PSI
Pressure Drop : 1/2" water column
Specific Gravity : 0.6
Cubic Feet per Hour : 121CFH [100,000 BTU / 825 BTU per Cubic Foot] per Questar Good Practices Handbook
- 3 PIPING All fuel gas piping shall be Schedule 40 metallic pipe. Metallic gas piping shall not be used outdoors or within six inches of the ground, unless it has been factory coated with approved materials that are acceptable for burial in the ground.
- 4 DERATION FACTORS Deration factors have been accounted for in CFH calculations per Manufacturer's specifications where applicable.
- 5 SEDIMENT TRAPS Sediment traps shall be installed as close to the inlet of an appliance or equipment as practical.
- 6 SHUT-OFF VALVES Shut-off valves shall be installed in the gas piping system ahead of all gas appliances, and must be accessible and in the same room as the appliances. Shut-off valves shall be within three feet of the appliance or equipment, or six feet to a gas dryer.
- 7 FLEXIBLE CONNECTORS Appliance and NFPA-approved flexible gas connectors from the gas pipe to the appliances shall be sized and installed in accordance with code requirements and Manufacturer's specifications.
- 8 PIPE ANCHORING AND SUPPORT Pipe anchoring and support shall comply with Section G2418 and G2424 of the 2015 IRC.

STEEL PIPE NOMINAL SIZE (INCHES)	PIPING SUPPORT	
	SPACING OF SUPPORTS (FEET)	SPACING OF TUBING OF TUBING (SMOOTH-WALL) SUPPORTS (INCH O.D.) (FEET)
1/2 or 3/4	6	4
1/2 or larger (horizontal)	8	6
1/2 or larger (vertical)	10	8
1/2 or larger (vertical)	Every floor level	1 or larger (vertical) Every floor level

PLAN REVIEW ACCEPTANCE
FOR COMPLIANCE WITH THE APPLICABLE CONSTRUCTION CODES IDENTIFIED BELOW

<input checked="" type="checkbox"/> BUILDING	<input checked="" type="checkbox"/> STRUCTURAL
<input checked="" type="checkbox"/> MECHANICAL	<input checked="" type="checkbox"/> PLUMBING
<input checked="" type="checkbox"/> ELECTRICAL	<input checked="" type="checkbox"/> ENERGY
<input type="checkbox"/> ACCESSIBILITY	<input type="checkbox"/> FIRE

PLAN REVIEW ACCEPTANCE OF DOCUMENTS DOES NOT AUTHORIZE CONSTRUCTION TO PROCEED IN VIOLATION OF ANY FEDERAL, STATE, OR LOCAL REGULATIONS.

BY: **MEM** DATE: 09/12/18
WEST COAST CODE CONSULTANTS, INC.

THESE PLANS ARE THE INTELLECTUAL PROPERTY OF IMBUE DESIGN, LLC AND ARE PROTECTED BY COMMON LAW, STATUTORY AND OTHER RESERVED RIGHTS INCLUDING, BUT NOT LIMITED TO, COPYRIGHT. THESE DRAWINGS MAY NOT BE REPRODUCED OR USED FOR ANY PURPOSE WITHOUT THE EXPLICIT WRITTEN CONSENT OF IMBUE DESIGN, LLC.

801.477.4174
949 Denver Street
SLC, Utah 84111
imbue design

M1.0
MECHANICAL
DETAILS

Revision 2
Date: 03.23.18
Construction Documents

Ridge Nest 14 at Summit
Eden, Utah 84310
ridge nest 14

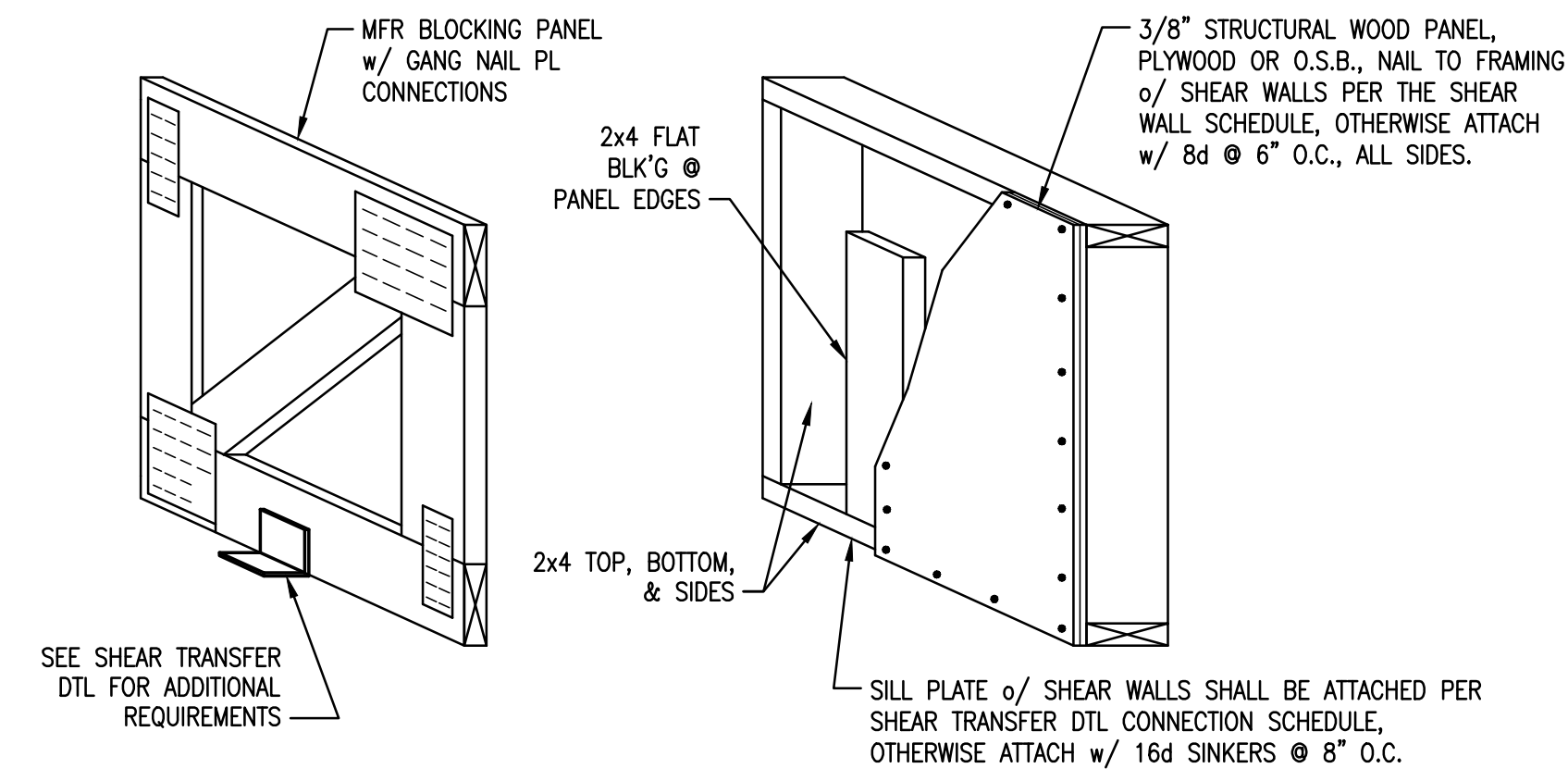

TYPICAL BLOCKING PANEL

N.T.S.

7

STUD WALL TYPE	STUD HEIGHT TABLE		
	BEARING AND/OR SHEAR WALLS (MAX. HEIGHT)		NON-BEARING AND NON-SHEAR WALLS (MAX. HEIGHT)
	EXTERIOR	INTERIOR	INTERIOR ONLY
2x4 STUD @ 16" O.C.	8'-6"	10'-0"	13'-0"
2x4 STUD @ 12" O.C.	9'-6"	11'-6"	14'-0"
(2) 2x4 STUD @ 16" O.C.	12'-0"	13'-6"	14'-0"
2x4 DFL #2 @ 16" O.C.	9'-0"	11'-0"	13'-0"
2x4 DFL #2 @ 12" O.C.	10'-6"	13'-0"	14'-0"
(2) 2x4 DFL #2 @ 16" O.C.	13'-0"	13'-6"	14'-0"
2x6 STUD @ 16" O.C.	14'-6"	19'-0"	20'-0"
2x6 STUD @ 12" O.C.	17'-0"	21'-0"	22'-0"
(2) 2x6 STUD @ 16" O.C.	21'-0"	22'-0"	22'-6"
2x6 DFL #2 @ 16" O.C.	16'-6"	19'-6"	20'-0"
2x6 DFL #2 @ 12" O.C.	18'-6"	21'-6"	22'-0"
(2) 2x6 DFL #2 @ 16" O.C.	22'-6"	22'-6"	22'-6"
2x8 DFL #2 @ 16" O.C.	22'-0"	26'-6"	27'-0"
2x8 DFL #2 @ 12" O.C.	25'-6"	28'-0"	30'-0"
(2) 2x8 DFL #2 @ 16" O.C.	29'-6"	29'-6"	30'-0"
1-3/4 x 7-1/4 LVL STUDS @ 16" O.C.	27'-0"	30'-0"	30'-0"
1-3/4 x 5-1/2 LVL STUDS @ 16" O.C.	20'-6"	21'-6"	22'-0"

NOTES:
 1. THIS TABLE ASSUMES IBC WIND LOADS w/ 115 mph, EXP. "C" AT EXTERIOR WALLS AND 5 psf LATERAL LOAD AT INTERIOR WALLS.
 2. THIS TABLE ASSUMES AXIAL DL = 710 lb/ft, LL = 760 lb/ft. AT EXTERIOR AND INTERIOR WALLS.
 3. THIS TABLE ASSUMES IBC 5psf LATERAL LOAD @ INTERIOR WALLS.

STANDARD STUD TABLE

N.T.S.

4

SHEAR WALL SCHEDULE						
MARK	MIN. BLOCKED MATERIAL	EDGE / BOUNDARY NAILING	FIELD NAILING	SOLE PL NAILING, WHERE OCCURS	SHEAR WALL CAPACITY	DEFAULT SILL ANCHORAGE, U.N.O.
PA	3/8" PLYWOOD OR O.S.B.	8d COMMON NAILS @ 6" O.C.	8d COMMON NAILS @ 12" O.C.	16d SINKERS @ 6" O.C.	260 pif	SA
PA	3/8" PLYWOOD OR O.S.B.	8d COMMON NAILS @ 4" O.C.	8d COMMON NAILS @ 12" O.C.	16d SINKERS @ 4" O.C.	350 pif	SA
PA	3/8" PLYWOOD OR O.S.B.	8d COMMON NAILS @ 3" O.C.	8d COMMON NAILS @ 12" O.C.	16d SINKERS @ 3" O.C.	490 pif	SA
PA	3/8" PLYWOOD OR O.S.B.	8d COMMON NAILS @ 2" O.C.	8d COMMON NAILS @ 12" O.C.	16d SINKERS @ 2" O.C.	640 pif	SA

SILL ANCHORAGE SCHEDULE

MARK	NOMINAL SILL PL THICKNESS	1/2" A.B. SPACING	5/8" A.B. SPACING	CAPACITY
SA	2x	32" O.C.	48" O.C.	370 pif
SA	2x	24" O.C.	32" O.C.	520 pif
SA	2x	16" O.C.	24" O.C.	740 pif
SA	2x	12" O.C.	16" O.C.	1040 pif

SHEAR WALL LENGTH TOLERANCES

SPECIFIED SHEAR WALL LENGTH	ACCEPTABLE SHEAR WALL TOLERANCE
UP TO 3'-0"	± 2"
OVER 3'-0" AND UP TO 5'-0"	± 3"
OVER 5'-0" AND UP TO 7'-0"	± 4"
OVER 7'-0" AND UP TO 10'-0"	± 6"
OVER 10'-0"	± 8"

- ALL SHEAR WALLS SHALL BE FRAMED TO THE MINIMUM LENGTHS SHOWN ON THE PLANS WITH THE TOLERANCES INDICATED ON THE TABLE ABOVE, U.N.O. ON PLAN w/ MINIMUM WALL LENGTH.
- ALL SHEAR WALLS SHALL TERMINATE ON AT LEAST (1) FULL HEIGHT STUD. ADDITIONAL STUDS OR SOLID POSTS SHALL BE INSTALLED AS REQUIRED FOR HOLDDOWNS WHERE THEY OCCUR.
- 8d COMMON NAIL SHANK DIAMETER = .131", 16d SINKER SHANK DIAMETER = .148"
- FOR "P3" AND "P4" SHEAR WALLS, ALL FRAMING RECEIVING EDGE NAILING FROM ADJOINING PANEL EDGES SHALL BE 3-INCH NOMINAL OR WIDER AND NAILS SHALL BE STAGGERED. AS AN ALTERNATE, (2) 2x STUDS MAY BE USED PROVIDED THEY ARE NAILED TOGETHER w/ (2) 16d SINKERS @ 6" O.C. FULL HEIGHT.
- FOR "P2", "P3" AND "P4" DOUBLE-SIDED SHEAR WALLS, PANEL JOINTS SHALL BE OFFSET TO FALL ON DIFFERENT FRAMING MEMBERS, OR FRAMING SHALL BE 3-INCH NOMINAL OR WIDER AT ADJOINING PANEL EDGES AND NAILS ON EACH SIDE SHALL BE STAGGERED.
- ALL ANCHOR BOLTS SHALL HAVE 7" MINIMUM EMBEDMENT.
- ALL SHEAR WALL ANCHOR BOLTS SHALL INCLUDE A STEEL 3"x3"x0.229" PLATE WASHER BETWEEN THE SILL PL & NUT. THE HOLE IN THE PLATE WASHER IS PERMITTED TO BE DIAGONALLY SLOTTED WITH A WIDTH OF UP TO 3/16" LARGER THAN THE BOLT DIAMETER AND A SLOT LENGTH NOT TO EXCEED 1 1/4". PROVIDED A STANDARD CUT WASHER IS PLACED BETWEEN THE PLATE WASHER AND THE NUT. ANCHOR BOLTS & PLATE WASHERS ARE TO BE OFFSET TOWARD THE SHEATHED WALL EDGE TO LIMIT THE GAP BETWEEN THE EDGE OF WASHER TO SHEATHING TO A MAXIMUM OF 1/2". WHERE BOTH SIDES OF A 2x6 WALL IS SHEATHED A STEEL 4-1/2"x3"x0.229" PLATE WASHER SHALL BE CENTERED ON THE SILL PLATE, PER DTL 2/-.

STANDARD SHEAR WALL SCHEDULE

N.T.S.

1

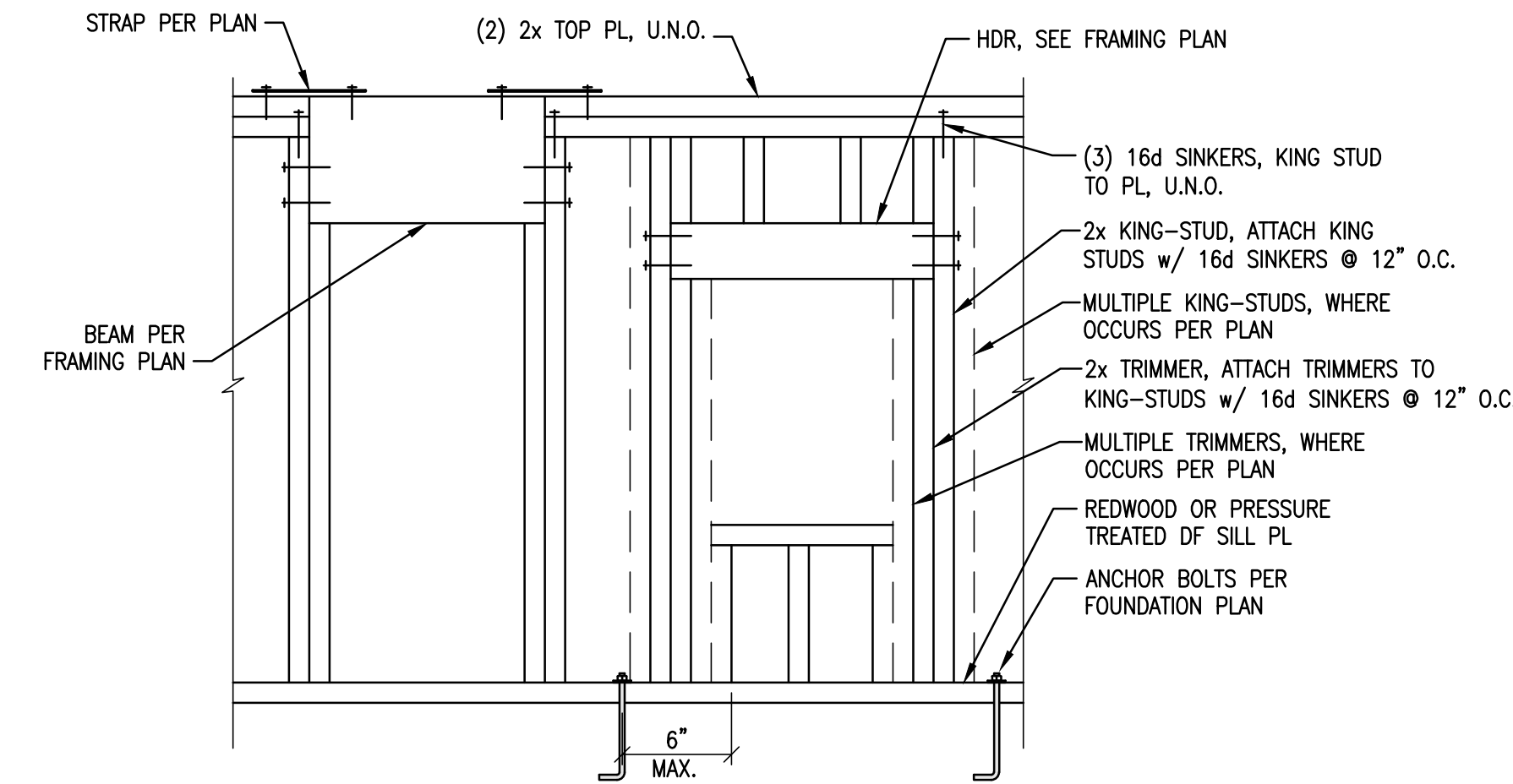

TYPICAL WALL FRAMING

N.T.S.

8

NOT USED

N.T.S.

5

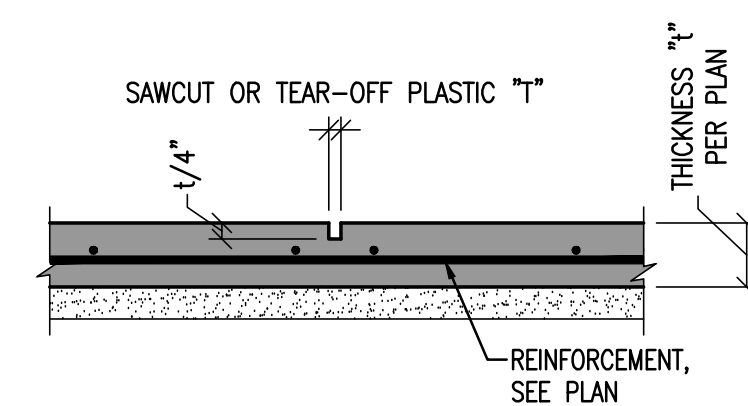

SLAB CONTROL JOINTS

N.T.S.

11

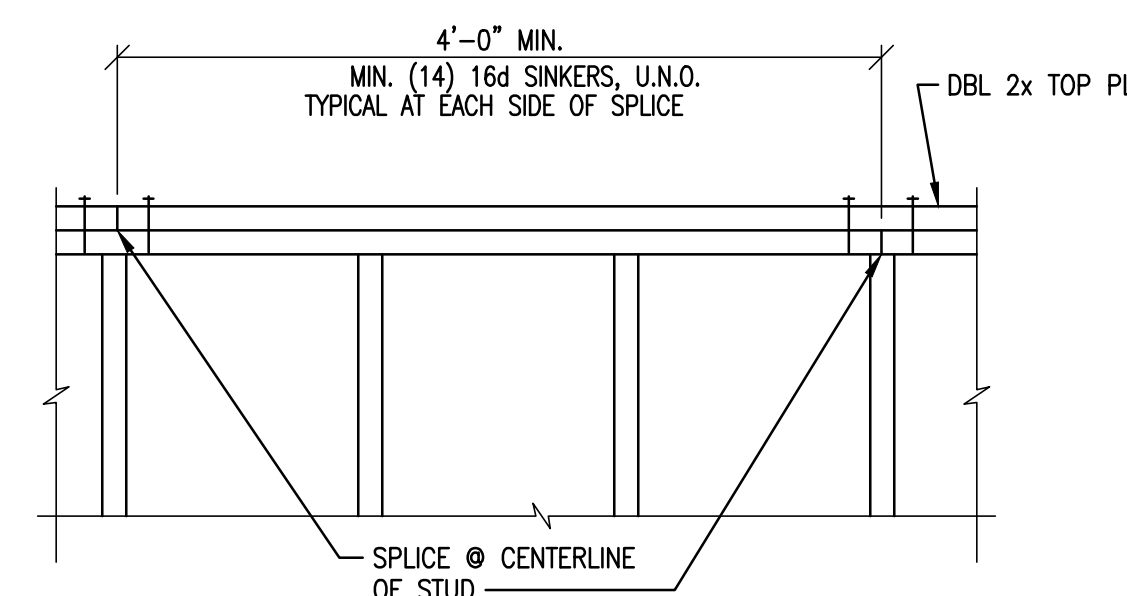

NOTE:
 WHERE SPLICE LENGTH IS LESS THAN 4'-0" INSTALL ST6224 STRAP AT PL SPLICES. STRAPS ARE NOT REQUIRED WHERE ONE OF THE PLATES IS CONTINUOUS FOR AT LEAST 4'-0" IN EACH DIRECTION.

TYPICAL TOP PLATE SPLICE

N.T.S.

9

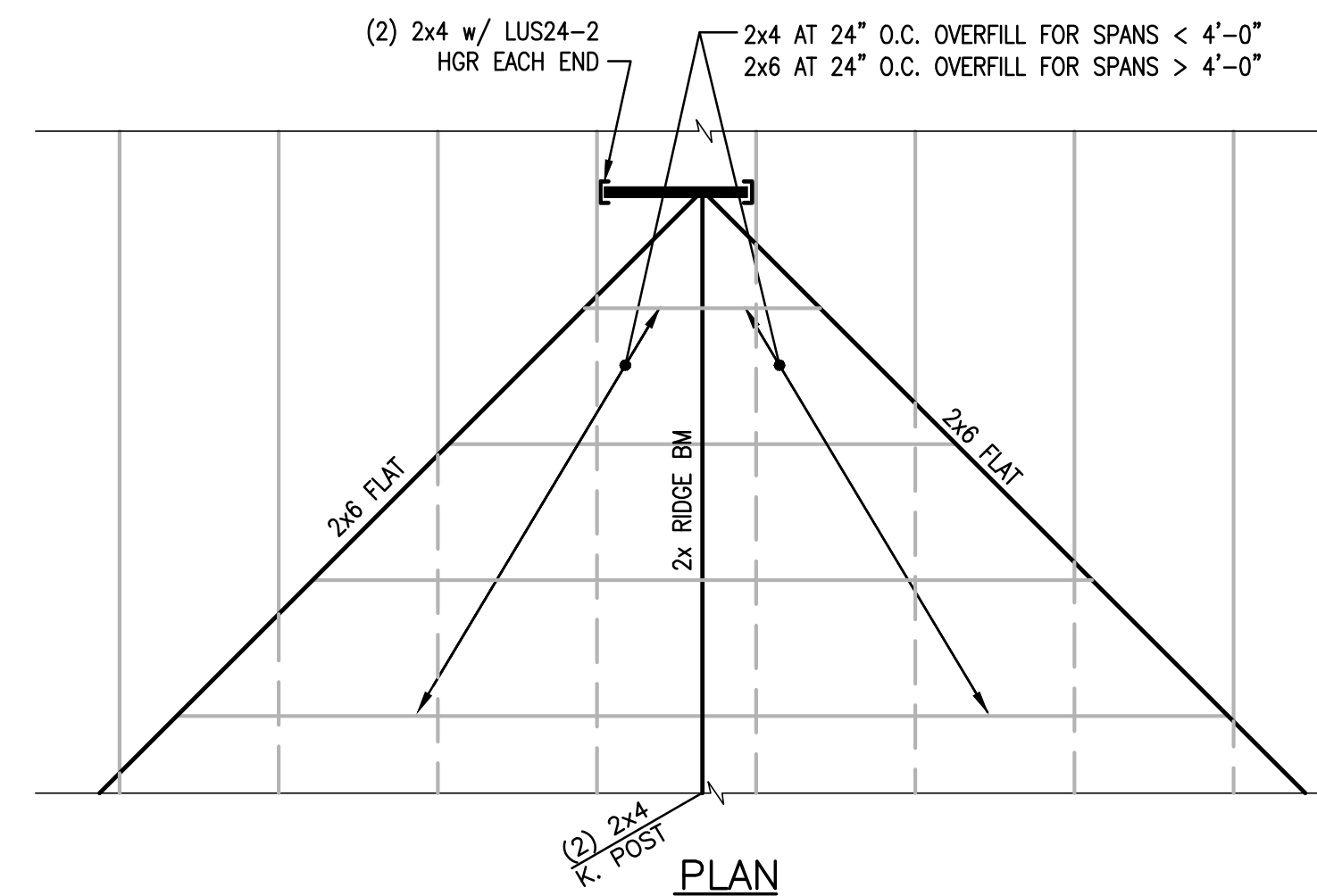

TYPICAL OVERBUILD

N.T.S.

6

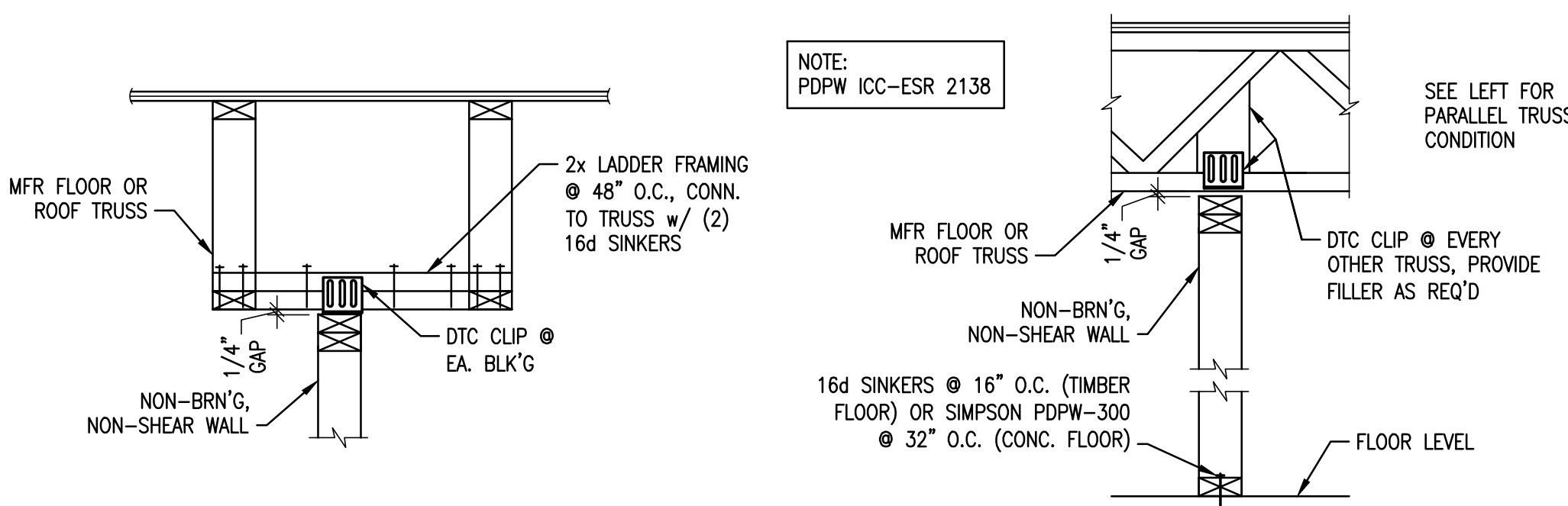

NON-BRN'G & NON-SHEAR WALL CONN.

N.T.S.

10

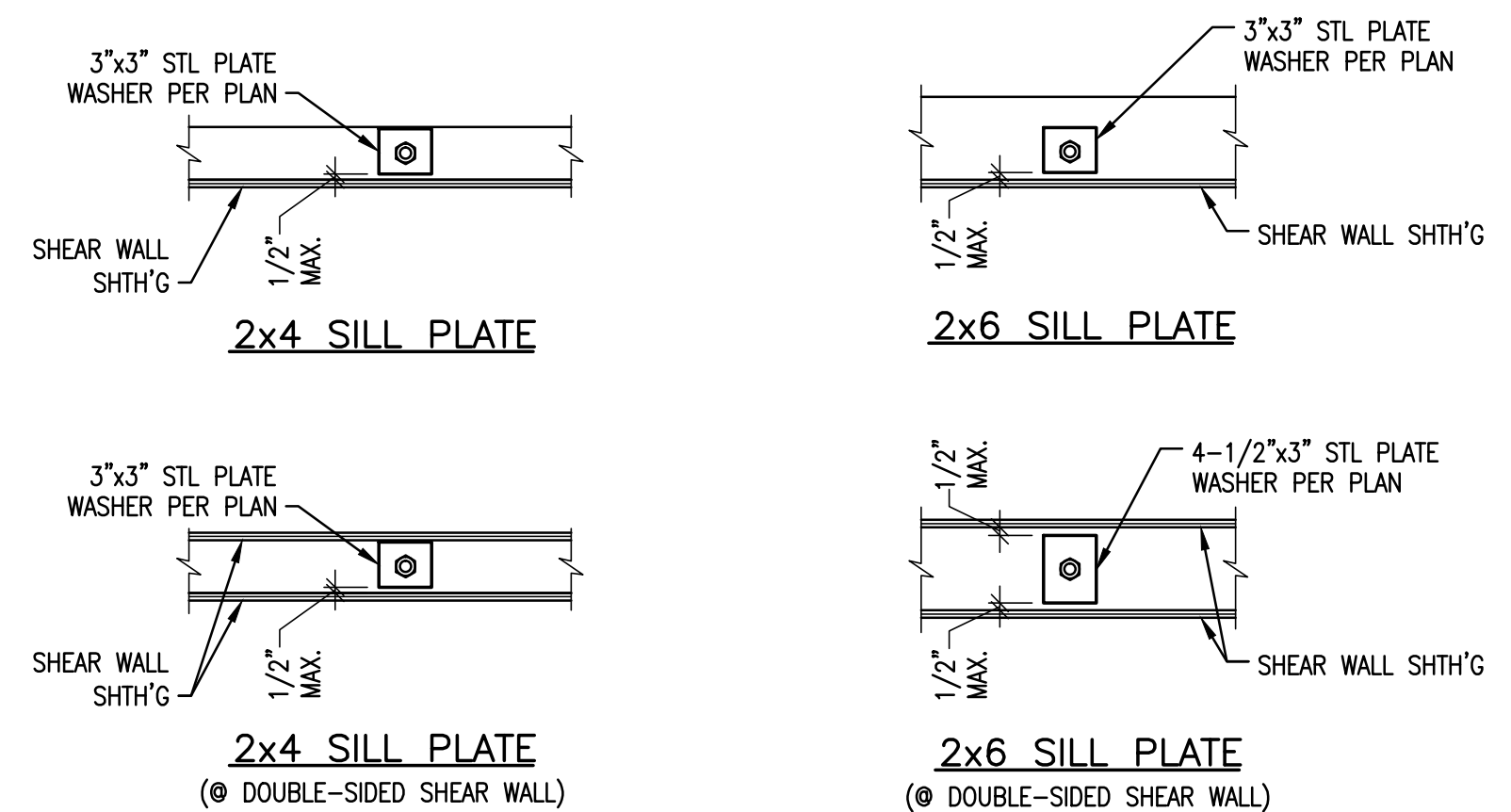

TYP. SHEAR WALL WASHERS

N.T.S.

2

FOOTING SCHEDULE		
MARK	SIZE	REINFORCING, BOTTOM
F2.0	2'-0" SQ. x 12" THICK	(3) #4 EACH WAY
F2.5	2'-6" SQ. x 12" THICK	(4) #4 EACH WAY
F3.0	3'-0" SQ. x 12" THICK	(4) #4 EACH WAY
F3.5	3'-6" SQ. x 12" THICK	(5) #4 EACH WAY
F4.0	4'-0" SQ. x 12" THICK	(6) #4 EACH WAY
F4.5	4'-6" SQ. x 12" THICK	(6) #4 EACH WAY
F5.0	5'-0" SQ. x 12" THICK	(7) #4 EACH WAY
F5.5	5'-6" SQ. x 12" THICK	(8) #4 EACH WAY
F6.0	6'-0" SQ. x 12" THICK	(8) #4 EACH WAY
F6.5	6'-6" SQ. x 12" THICK	(9) #4 EACH WAY
F7.0	7'-0" SQ. x 12" THICK	(10) #4 EACH WAY

STANDARD FOOTING SCHEDULE

N.T.S.

3

DATE	REV. #	DESCRIPTION
07/12/18		

VECTOR ENGINEERS
 DRAPER, UTAH
 (801) 990-1775
 WWW.VECTORSE.COM

Copyright © 2018
 Vector Structural Engineering, LLC
 This drawing contains proprietary information belonging to Vector Structural Engineering, LLC and may be neither wholly nor partially copied or reproduced without the prior written permission of Vector Structural Engineering, LLC.

CIPRIAN MORAR / IMBUE DESIGN
RIDGE NEST 14 AT SUMMIT POWDER MOUNTAIN
 EDEN, UT

STANDARD DETAILS & SCHEDULES

PROFESSIONAL STRUCTURAL ENGINEERING
 No. 525244
 CIPRIAN MORAR
 STATE OF UTAH
 8/29/18
 RUSSELL N. EMERY, S.E.
 #5252124

U2784-001-181

S1.1

Required Verification and Inspection of Steel Construction			
Verification and Inspection	Frequency		Referenced Standard
	Continuous	Periodic	
1. Material verification of high-strength bolts, nuts and washers:			
a. Identification markings to conform to ASTM standards specified in the approved construction documents.	<input type="checkbox"/>	<input type="checkbox"/>	AISC 360, Section A3.3 and applicable ASTM material standards
b. Manufacturer's certificate of compliance required.	<input type="checkbox"/>	<input type="checkbox"/>	<input type="checkbox"/>
2. Inspection of high-strength bolting:			
a. Snug-tight joints.	<input type="checkbox"/>	<input type="checkbox"/>	AISC 360, Section M2.5
b. Pretensioned and slip-critical joints using turn-of-nut with matchmarking, twist-off bolt or direct tension indicator methods of installation.	<input type="checkbox"/>	<input type="checkbox"/>	
c. Pretensioned and slip-critical joints using turn-of-nut without matchmarking or calibrated wrench methods of installation.	<input type="checkbox"/>	<input type="checkbox"/>	
3. Material verification of structural steel and cold-formed steel deck:			
a. For structural steel, identification markings to conform to AISC 360.	<input type="checkbox"/>	<input type="checkbox"/>	AISC 360, Section M5.5
b. Manufacturer's certified test reports.	<input type="checkbox"/>	<input type="checkbox"/>	<input type="checkbox"/>
4. Material verification of weld filler materials:			
a. Identification markings to conform to AWS specification in the approved construction documents.	<input type="checkbox"/>	<input type="checkbox"/>	AISC 360, Section A3.5 and applicable AWS A5 documents
b. Manufacturer's certificate of compliance required.	<input type="checkbox"/>	<input type="checkbox"/>	<input type="checkbox"/>
5. Inspection of welding:			
a. Structural steel and cold-formed steel deck:			
1) Complete and partial joint penetration groove welds.	<input type="checkbox"/>	<input type="checkbox"/>	AWS D1.1
2) Multipass fillet welds.	<input type="checkbox"/>	<input type="checkbox"/>	
3) Single-pass fillet welds > 5/16"	<input type="checkbox"/>	<input type="checkbox"/>	
4) Plug and slot welds.	<input type="checkbox"/>	<input type="checkbox"/>	
5) Single-pass fillet welds ≤ 5/16"	<input type="checkbox"/>	<input type="checkbox"/>	
6. Inspection of steel frame joint details for compliance:			
a. Details such as bracing and stiffening.			
b. Member locations.	<input type="checkbox"/>	<input type="checkbox"/>	<input type="checkbox"/>
c. Application of joint details at each connection.			

PLATE NOTCHES OR HOLES

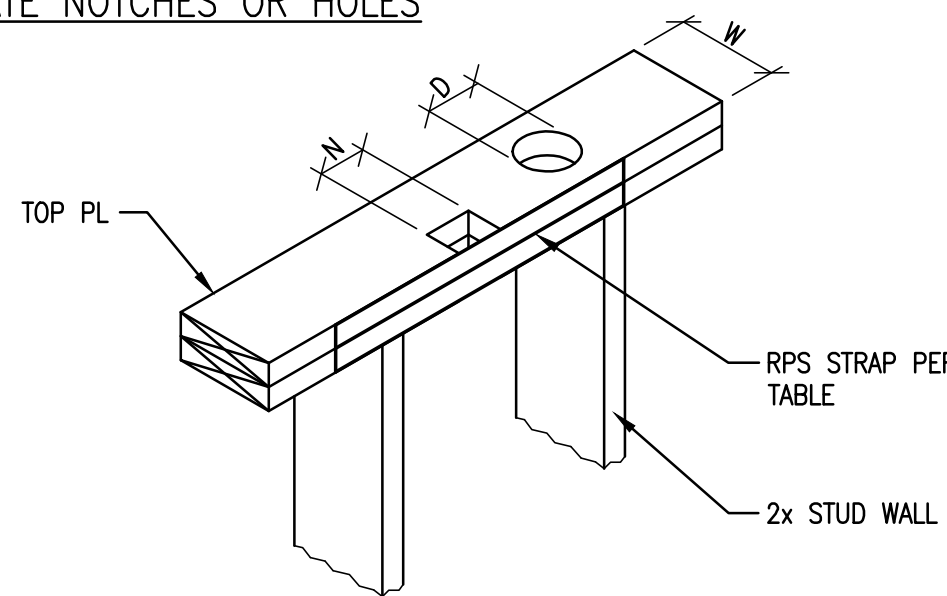

2x4 PLATE	2x6 PLATE	2x4 & 2x6 PLATE	RPS STRAP
HOLE DIA 'D'	HOLE DIA 'D'	NOTCH WIDTH 'N' (MAX. NOTCH DEPTH = W/2)	
≤ 7/8"	≤ 1"	≤ 1"	NONE
≤ 1"	≤ 1 3/8"	≤ 2 1/2"	(1) RPS18
≤ 1 3/8"	≤ 2 1/8"	≤ 5 1/2"	(2) RPS18
≤ 2"	≤ 3 1/4"	≤ 12"	(2) RPS28

NOTES:

- USE RPS28 FOR SILL PLATE.
- CENTER STRAPS @ NOTCH OR HOLE.
- WHERE ROOF TRUSS OR FLOOR JOIST IS BEARING WITHIN STUD BAY OF THE HOLE OR NOTCH, INSTALL AN ADDITIONAL STUD DIRECTLY BELOW THE TRUSS OR JOIST UNLESS NO RPS STRAP IS REQUIRED OR WHERE EXISTING STUD FACE IS WITHIN 3" OF TRUSS OR JOIST FACE.
- NOTCHES & HOLES MUST BE SEPARATED BY "2x0" OR "2x4".
- WHERE MULTIPLE HOLES ARE LOCATED ADJACENT TO EACH OTHER, THE STRAP REPAIR MAY BE WITH A CS16 STRAP ON EACH SIDE OF THE UPPER PLATE. THE STRAPS AND NAILING SHALL EXTEND AT LEAST 9" BEYOND EACH END OF THE WHOLE GROUP. NAILING BETWEEN THE HOLES IS NOT REQUIRED. NAILS IN THE CS16 STRAPS MAY BE N8'S OR N10'S.

STUD NOTCHES OR HOLES

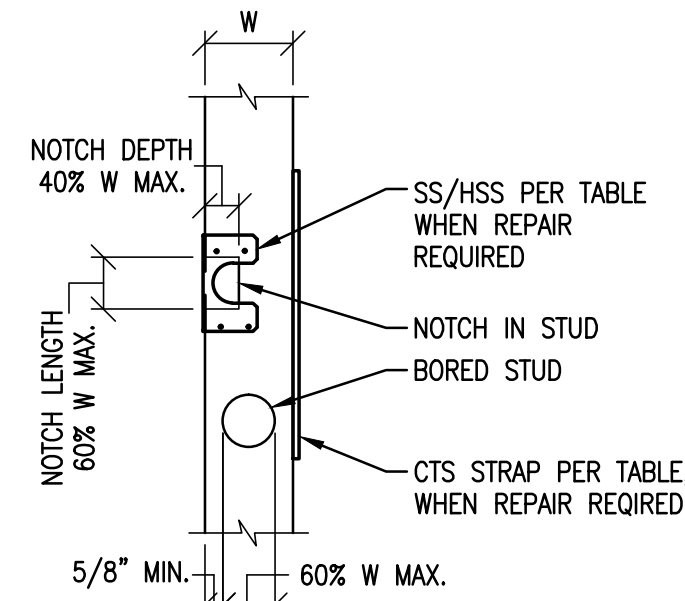

HOLE / NOTCH SCHEDULE			
HOLE / NOTCH % OF 'W'	2x4 STUD	2x6 STUD	REPAIR
25%	3/4"	1-3/8"	
40%	1-3/8"	2-1/8"	
60%	2"	3-1/4"	

NOTES:

- HOLES & NOTCHES SHALL NOT OCCUR IN THE SAME STUD.
- WHERE HOLES OR NOTCHES EXCEED THOSE SHOWN ABOVE, REPAIR PER TABLE BELOW.
- ALL NOTCHES IN BEARING OR SHEAR OR EXTERIOR WALLS REQUIRE REPAIRS.

Required Verification and Inspection of Soils

Verification and Inspection	Frequency		Referenced Standard
	Continuous	Periodic	
1. Verify materials below shallow foundations are adequate to achieve the design bearing capacity.			
2. Verify excavations are extended to proper depth and have reached proper material.	<input type="checkbox"/>	<input type="checkbox"/>	<input type="checkbox"/>
3. Perform classification and testing of compacted fill materials	<input type="checkbox"/>	<input type="checkbox"/>	<input type="checkbox"/>
4. Verify use of proper materials, densities and lift thicknesses during placement and compaction of compacted fill.	<input type="checkbox"/>	<input type="checkbox"/>	<input type="checkbox"/>
5. Prior to placement of compacted fill, observe subgrade and verify that site has been prepared properly.	<input type="checkbox"/>	<input type="checkbox"/>	<input type="checkbox"/>

Required Verification and Inspection of Concrete Construction

Verification and Inspection	Frequency		Referenced Standard
	Continuous	Periodic	
1. Inspection of reinforcing steel, including prestressing tendons, and placement.			
2. Inspection of anchors installed in hardened concrete.	<input type="checkbox"/>	<input type="checkbox"/>	ACI 318: 3.8.6, 8.1.3, 21.2.8
3. At the time fresh concrete is sampled to fabricate specimens for strength tests, perform slump and air content tests, and determine the temperature of the concrete.	<input type="checkbox"/>	<input type="checkbox"/>	ASTM C 172, ASTM C 31, ACI 318: 5.6, 5.8
4. Inspect formwork for shape, location and dimensions of the concrete member being formed.	<input type="checkbox"/>	<input type="checkbox"/>	ACI 318: 6.1.1

SPECIAL INSPECTION SCHEDULES

8/29/2016 6:08 PM

7

DRILLING & NOTCHING OF PLATES & STUDS

N.T.S.

6

TYPICAL TRUSS HANGERS

N.T.S.

4

NOT USED

N.T.S.

5

MFR TRUSS TO BEAM HANGERS

CARRYING MEMBER	CARRIED MBR WIDTH	HANGER TYPE	MAX. REACTION (FROM TRUSS CALC.S.) (LBS)	NOTES
STEEL OR TIMBER	1-1/2"	LUS210	1275	FACE MOUNT
STEEL OR TIMBER	1-1/2"	HUS26	2565	FACE MOUNT
STEEL OR TIMBER	1-1/2"	HGUS26	3750	FACE MOUNT
STEEL OR TIMBER	1-1/2"	HGUS28	5720	FACE MOUNT
STEEL OR TIMBER	3"	LUS26-2	1000	FACE MOUNT
STEEL OR TIMBER	3"	HHUS26-2	2580	FACE MOUNT
STEEL OR TIMBER	3"	HGUS26-2	3940	FACE MOUNT
STEEL OR TIMBER	3"	HGUS28-2	6805	FACE MOUNT
STEEL OR TIMBER	3"	HGUS210-2	8650	FACE MOUNT
STEEL OR TIMBER	3-1/2"	LUS46	1000	FACE MOUNT
STEEL OR TIMBER	3-1/2"	HHUS46	2580	FACE MOUNT
STEEL OR TIMBER	3-1/2"	HGUS46	3940	FACE MOUNT
STEEL OR TIMBER	3-1/2"	HGUS48	6805	FACE MOUNT
STEEL OR TIMBER	6"	HGUS26-4	3940	FACE MOUNT
STEEL OR TIMBER	6"	HGUS210-4	8780	FACE MOUNT
STEEL OR TIMBER	6"	HGUS212-4	9155	FACE MOUNT

NOTES:

- FOR STEEL BEAMS CARRYING FLOOR TRUSSES, PROVIDE TIMBER FILLER PER DTL BELOW.
- ALTERNATE HANGERS MAY BE USED AT THE CONTRACTOR'S OPTION. SUBMIT TO ENGINEER OF RECORD FOR APPROVAL.
- HANGERS APPLICABLE FOR TIMBER BEAMS.

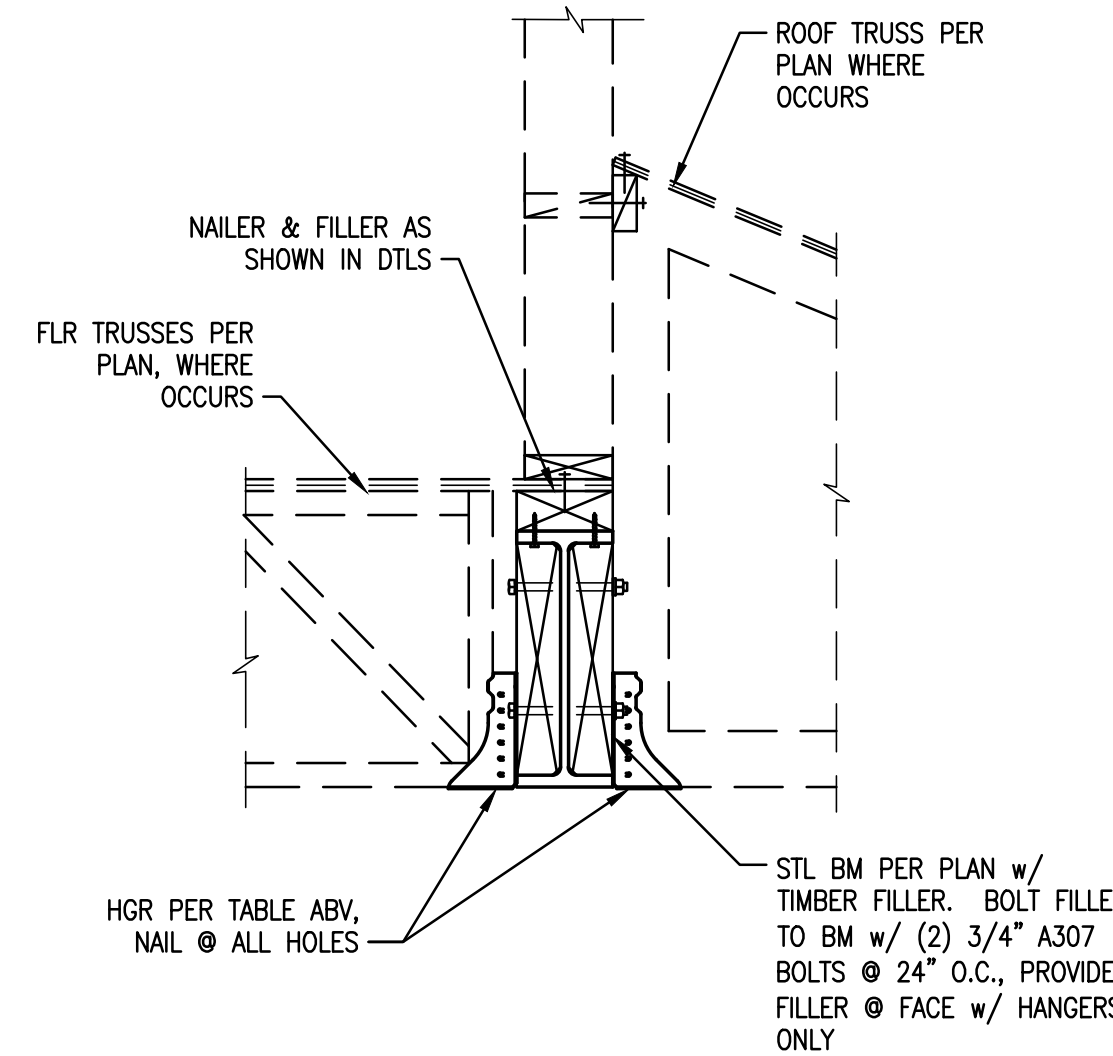

TYPICAL STEEL BEAM

STANDARD TRUSS TIE-DOWNS

UPLIFT LOAD PER TRUSS MANUFACTURER	SIMPSON TIE-DOWN	REQ'D ALIGNED HOLDOWN & POST
200 TO 365 LBS	H2.5 OR CS16	NOT REQ'D
< 400 LBS	H1 OR CS16	NOT REQ'D
< 845 LBS	H10 OR H7Z OR CS16	NOT REQ'D
< 1265 LBS	H16 OR CS16	HDU2 & (2) 2x4 POST
< 1785 LBS	LGT2	HDU2 & (2) 2x4 POST
< 6485 LBS	HGT-2	(2) 2x4 POST w/HDU4 @ BASE & (2) HDU2 @ TOP TO HGT-2. AT (1) PLY TRUSS, INSTALL 2x SHAPED FILLER ADJACENT TO TRUSS AT BEARING

NOTES:

- TIE-DOWN CAPACITIES ARE BASED ON SPRUCE PINE FIR
- TRUSS UPLIFT OF LESS THAN 200lbs: TIE-DOWN REQ'D
- SEE TYPICAL HOLDOWN ANCHORAGE DETAIL FOR HDU HOLDOWN INSTALLATION

STANDARD FLOOR-TO-FLOOR STRAPS

UPLIFT LOAD PER TRUSS MANUFACTURER	SIMPSON TIE-DOWN	REQ'D ALIGNED POST
< 1705 LBS	CS16	2x4 POST
< 3410 LBS	(2) CS16	(2) 2x4 POST

NOTES:

- INSTALL CS16 STRAPS TO 2x STUDS ABOVE AND BELOW FLOOR FRAMING. NAIL EACH END w/ (1) 10d NAILS. (STRAP LENGTH = 48").
- WHERE UPLIFT OCCURS ABOVE HDR OR BM, INSTALL STRAP PER SCHEDULE AT EACH TRIMMER OR POST
- FLOOR TO FLOOR STRAPS REQ'D ALIGNED WITH ROOF TRUSS ABV.

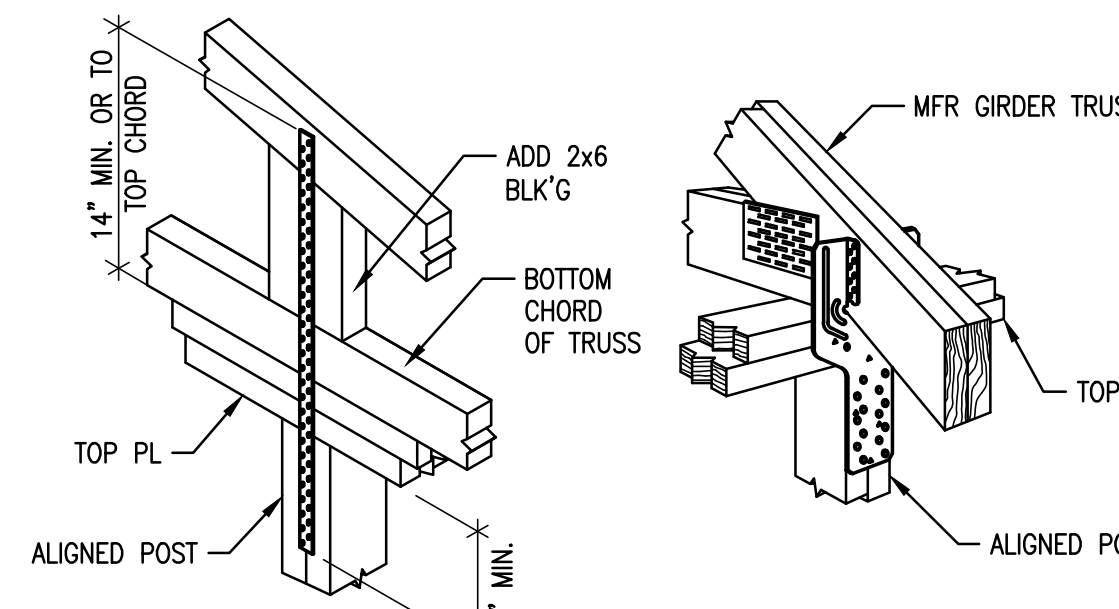

TYPICAL CS16

TYPICAL LGT2 INSTALLATION

TYPICAL TRUSS ANCHORAGE

N.T.S.

2

NOT USED

N.T.S.

3

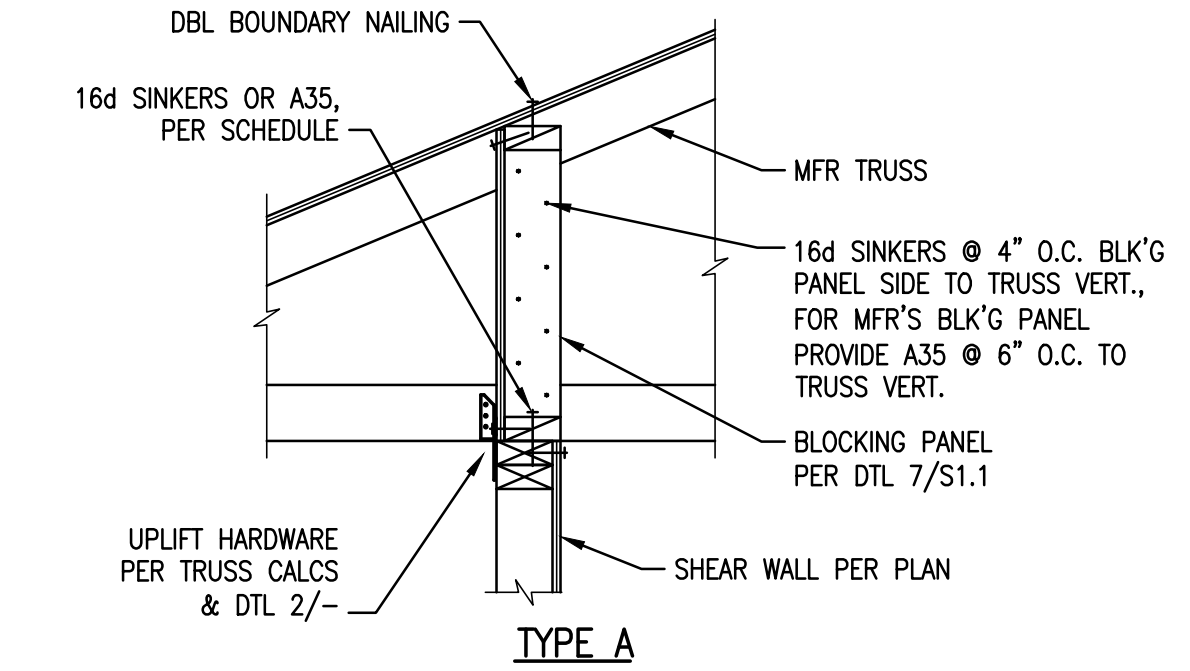

TYPE A

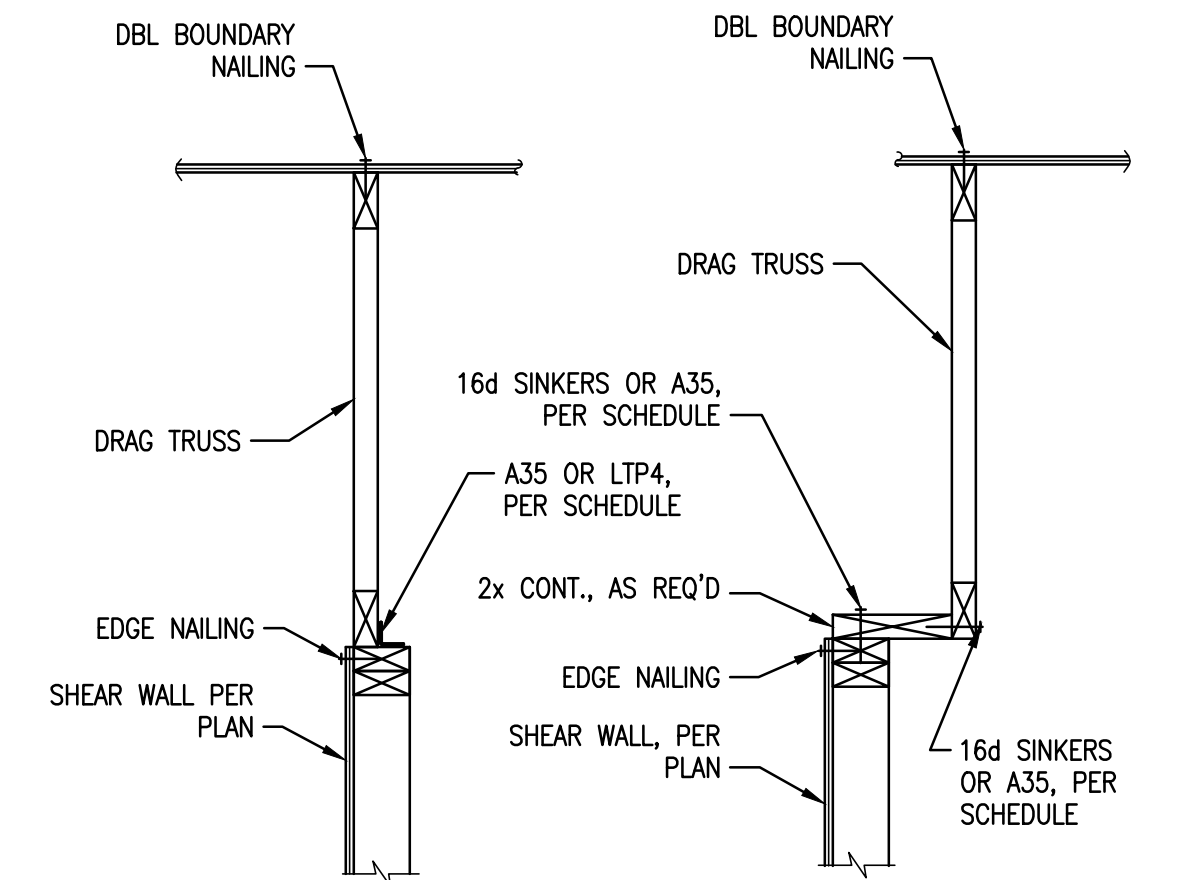

TYPE B

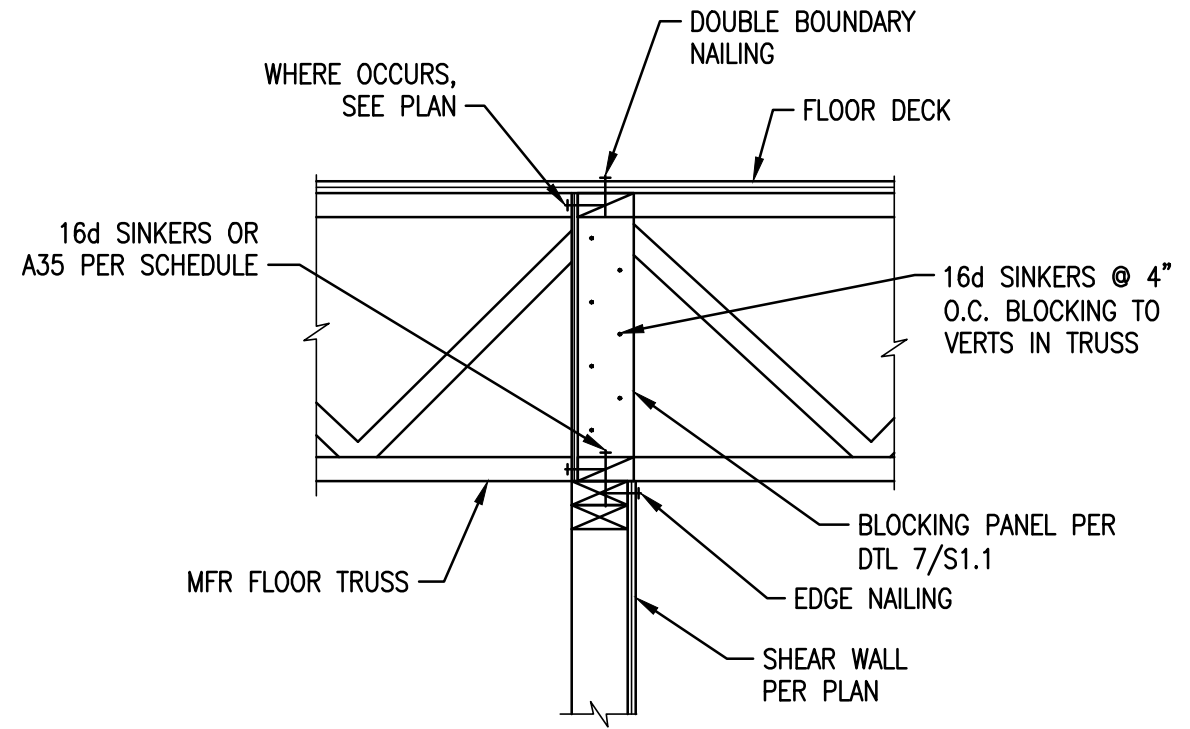

TYPE C

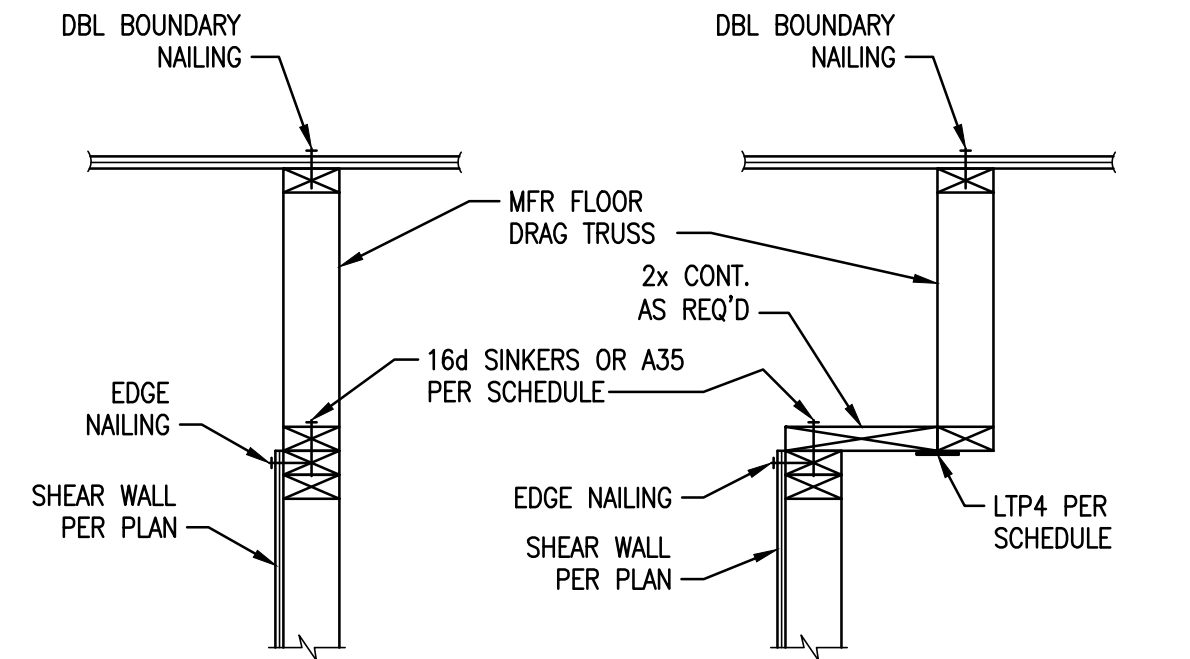

TYPE D

CONNECTION SCHEDULE		
SHEAR WALL	A35 OR LTP4	16d SINKERS
P1	18" O.C.	6" O.C.
P2	12" O.C.	4" O.C.
P3	10" O.C.	3" O.C. (STAGGERED)
P4	8" O.C.	2" O.C. (STAGGERED)

N.T.S.

DATE: 07/12/18	REV. #	BY	DATE	DESCRIPTION

VECTOR ENGINEERS
 DRAPER, UTAH
 (801) 990-1775
 WWW.VECTORSE.COM

Copyright © 2018
 Vector Structural Engineering, LLC
 This drawing contains proprietary information belonging to Vector Structural Engineering, LLC, and may be neither wholly nor partially copied or reproduced without the prior written permission of Vector Structural Engineering, LLC.

CIPRIAN MORAR / IMBUE DESIGN
RIDGE NEST 14 AT SUMMIT POWDER MOUNTAIN
 EDEN, UT

STANDARD DETAILS & SCHEDULES

PROFESSIONAL STRUCTURAL ENGINEER
 No. 5252124
 RUSSELL N. EMERT, S.E.
 8/29/18
 #5252124

U2784-001-181

S1.2

PLAN REVIEW ACCEPTANCE
 FOR COMPLIANCE WITH THE APPLICABLE CONSTRUCTION CODES IDENTIFIED BELOW:
 BUILDING STRUCTURAL
 MECHANICAL PLUMBING
 ELECTRICAL ENERGY
 ACCESSIBILITY FIRE
 PLAN REVIEW ACCEPTANCE OF DOCUMENTS DOES NOT AUTHORIZE CONSTRUCTION TO PROCEED IN VIOLATION OF ANY FEDERAL, STATE, OR LOCAL REGULATIONS.
 BY: MEM DATE: 08/12/18
 WEST COAST CODE CONSULTANTS, INC.

- FOUNDATION NOTES:**
1. ALL DIMENSIONS ARE PER ARCHITECTURAL DRAWINGS.
 2. ALL EXTERIOR WALLS, INTERIOR BEARING WALLS & SHEAR WALLS TO BE ATTACHED TO THE FOUNDATION w/ 1/2" x 10" LONG ANCHOR BOLTS (7" EMBED.) AT 32" O.C., U.N.O. SEE THIS PLAN & SHEAR WALL SCHEDULE FOR ANCHOR BOLT REQUIREMENTS AT SHEAR WALLS. ANCHOR BOLTS AT SHEAR WALLS TO HAVE WASHERS PER SHEAR WALL SCHEDULE (S1.1). ALL OTHER ANCHOR BOLTS TO HAVE WASHERS PER NOTE "E" IN GENERAL NOTES (S1).
 3. ALL HOLDDOWNS SHALL BE INSTALLED AS SHOWN ON DETAIL 9/SD-1.
 4. ISOLATED FOOTINGS & INTERIOR STRIP FOOTINGS TO BE CENTERED BELOW POSTS & BEARING/SHEAR WALLS, RESPECTIVELY.
 5. SEE SHEET S1.1 FOR FOOTING SCHEDULE.
 6. MASA MUDSILL ANCHORS MAY BE USED IN PLACE OF ANCHOR BOLTS, INSTALLED AT THE SAME SPACING INDICATED FOR ANCHOR BOLTS, INCLUDING REDUCED SPACING AT SHEAR WALLS.

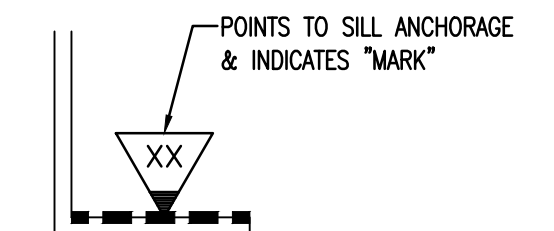

NOTE:
SEE SHEET S1.1 FOR SILL ANCHORAGE SCHEDULE

SILL ANCHORAGE KEY

DATE	REV #	DATE	BY	DESCRIPTION
07/12/18		08-28-18	JBA	AS SHOWN



Copyright © 2018
Vector Structural Engineering, LLC
This drawing contains proprietary information belonging to Vector Structural Engineering, LLC. and may be neither wholly nor partially copied or reproduced without the prior written permission of Vector Structural Engineering, LLC.

CIPRIAN MORAR / IMBUE DESIGN
RIDGE NEST 14 AT SUMMIT POWDER MOUNTAIN
EDEN, UT
LOW FOUNDATION PLAN

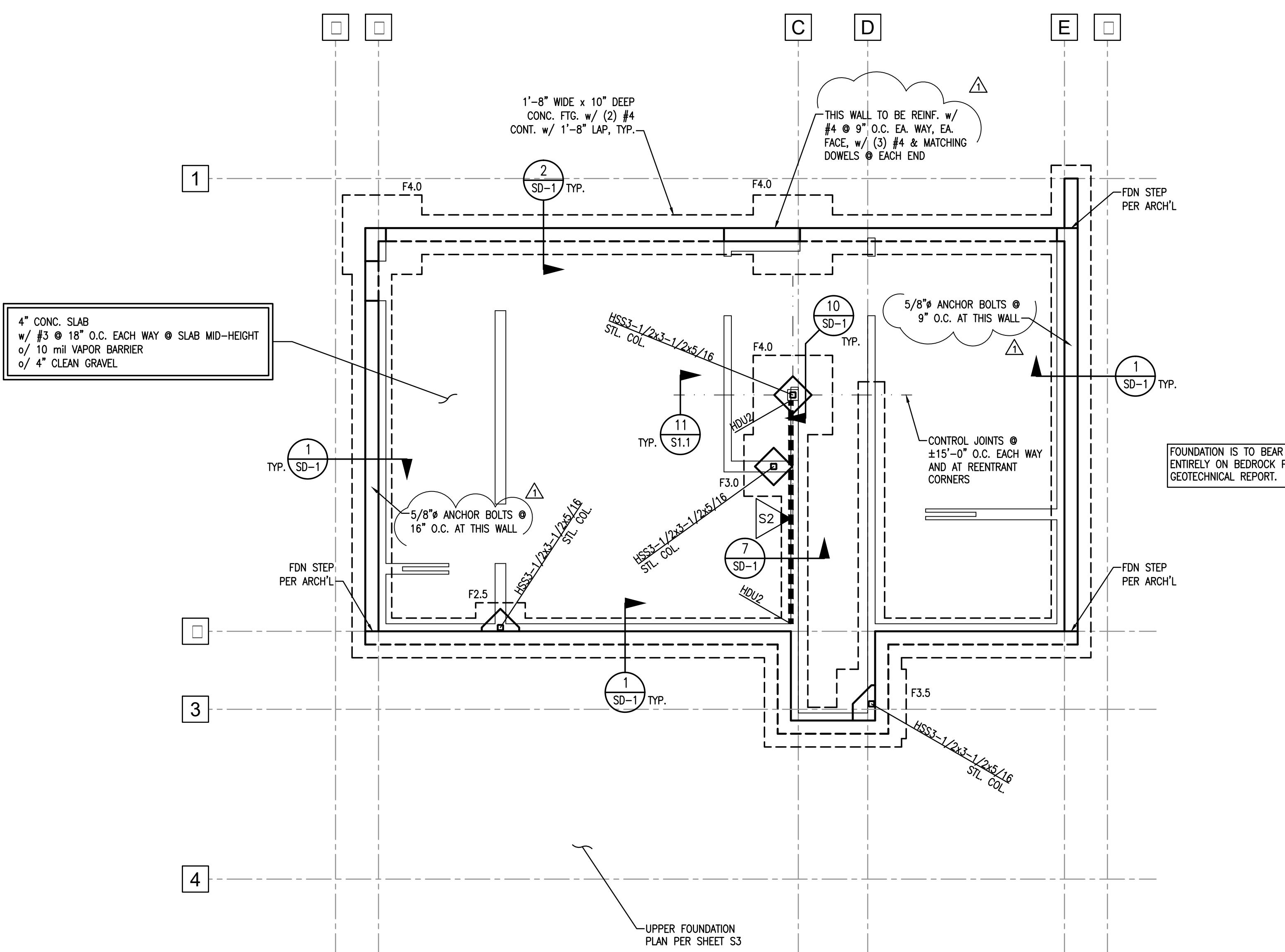

4" CONC. SLAB
w/ #3 @ 18" O.C. EACH WAY @ SLAB MID-HEIGHT
o/ 10 mil VAPOR BARRIER
o/ 4" CLEAN GRAVEL

FOUNDATION IS TO BEAR ENTIRELY ON BEDROCK PER GEOTECHNICAL REPORT.

LOW FOUNDATION PLAN

1/4" = 1'-0"

PLAN REVIEW ACCEPTANCE
FOR COMPLIANCE WITH THE APPLICABLE CONSTRUCTION CODES IDENTIFIED BELOW.

<input checked="" type="checkbox"/> BUILDING	<input checked="" type="checkbox"/> STRUCTURAL
<input checked="" type="checkbox"/> MECHANICAL	<input checked="" type="checkbox"/> PLUMBING
<input checked="" type="checkbox"/> ELECTRICAL	<input checked="" type="checkbox"/> ENERGY
<input type="checkbox"/> ACCESSIBILITY	<input type="checkbox"/> FIRE

PLAN REVIEW ACCEPTANCE OF DOCUMENTS DOES NOT AUTHORIZE CONSTRUCTION TO PROCEED IN VIOLATION OF ANY FEDERAL, STATE, OR LOCAL REGULATIONS.

by: **MEM** DATE: 09/12/18
WEST COAST CODE CONSULTANTS, INC.

PROFESSIONAL STRUCTURAL ENGINEER
No. 5252124
RUSSELL N. EMERY, S.E.
STATE OF UTAH
8/29/18
RUSSELL N. EMERY, S.E.
#5252124

U2784-001-181

S2

FOUNDATION NOTES:

- ALL DIMENSIONS ARE PER ARCHITECTURAL DRAWINGS.
- ALL EXTERIOR WALLS, INTERIOR BEARING WALLS & SHEAR WALLS TO BE ATTACHED TO THE FOUNDATION w/ 1/2" x 10" LONG ANCHOR BOLTS (7" EMBED.) AT 32" O.C., U.N.O. SEE THIS PLAN & SHEAR WALL SCHEDULE FOR ANCHOR BOLT REQUIREMENTS AT SHEAR WALLS. ANCHOR BOLTS AT SHEAR WALLS TO HAVE WASHERS PER SHEAR WALL SCHEDULE (S1.1). ALL OTHER ANCHOR BOLTS TO HAVE WASHERS PER NOTE "E" IN GENERAL NOTES (S1).
- ALL HOLDDOWNS SHALL BE INSTALLED AS SHOWN ON DETAIL 9/SD-1.
- ISOLATED FOOTINGS & INTERIOR STRIP FOOTINGS TO BE CENTERED BELOW POSTS & BEARING/SHEAR WALLS, RESPECTIVELY.
- SEE SHEET S1.1 FOR FOOTING SCHEDULE.
- MASA MUDSILL ANCHORS MAY BE USED IN PLACE OF ANCHOR BOLTS, INSTALLED AT THE SAME SPACING INDICATED FOR ANCHOR BOLTS, INCLUDING REDUCED SPACING AT SHEAR WALLS.

FRAMING NOTES:

- ALL FRAMED WALLS TO BE 2x @ 16" O.C. (MAX) PER ARCHITECTURAL PLANS AND SHALL MEET REQUIREMENTS OF WALL TABLE ON SHEET S1.1.
- FOR 2x4 FRAMED WALLS AT HEADERS (HDR):
 - PROVIDE (1) 2x4 TRIMMER & (1) 2x4 KING STUD AT OPENINGS < 6'-0" U.N.O.
 - PROVIDE (2) 2x4 TRIMMERS & (2) 2x4 KING STUDS AT OPENINGS ≥ 6'-0" & ≤ 10'-0" U.N.O.
 - PROVIDE (2) 2x4 TRIMMERS & (3) 2x4 KING STUDS AT OPENINGS ≥ 10'-0" & ≤ 18'-0" U.N.O. (1) KING STUD REQUIRED AT BAY WINDOW OPENINGS & AT GARAGE STUDS WHERE ADDITIONAL KING STUDS WOULD NOT FIT. NOTE: KINGSTUDS NOT REQUIRED AT BEAMS (BM)
- FOR 2x6 FRAMED WALLS AT HEADERS (HDR):
 - PROVIDE (1) 2x6 TRIMMER & (1) 2x6 KING STUD AT OPENINGS < 8'-0" U.N.O.
 - PROVIDE (2) 2x6 TRIMMERS & (2) 2x6 KING STUDS AT OPENINGS ≥ 8'-0" & ≤ 12'-0" U.N.O.
 - PROVIDE (2) 2x6 TRIMMERS & (3) 2x6 KING STUDS AT OPENINGS ≥ 12'-0" & ≤ 20'-0" U.N.O.
- FOR 2x8 FRAMED WALLS AT HEADERS (HDR):
 - PROVIDE (1) 2x8 TRIMMER & (1) 2x8 KING STUD AT OPENINGS < 8'-0" U.N.O.
 - PROVIDE (2) 2x8 TRIMMERS & (2) 2x8 KING STUDS AT OPENINGS ≥ 8'-0" & ≤ 12'-0" U.N.O.
 - PROVIDE (2) 2x8 TRIMMERS & (3) 2x8 KING STUDS AT OPENINGS ≥ 12'-0" & ≤ 20'-0" U.N.O.
- FACE NAIL MULTIPLE 2x POSTS WITH 16d SINKERS @ 6" O.C.
- SHADED AREAS ARE TYPICAL OVERTILL, STICK FRAMED PER DETAIL 6/S1.1 OR OVERBUILD TRUSSES PER TRUSS MANUFACTURER
- INTERIOR BEARING WALLS
- ALL GLULAM BEAMS TO HAVE STANDARD CAMBER (R = 2000') U.N.O.
- PROVIDE (2) 2x POST, EACH END OF ALL BEAMS & GIRDER TRUSSES, U.N.O.
- BEAM AND HEADER SIZES INDICATED ON THE PLANS ARE MINIMUM SIZES. LARGER SIZES MAY BE INSTALLED AT THE CONTRACTOR'S OPTION.
- CONTINUOUS TOP PLATE MAY BE USED IN LIEU OF ST6224 STRAP FROM BEAM TO PLATE.

DATE: 07/12/18	ENG: JBA	CHK: RNE
REV #	DATE	DESCRIPTION
1	08-28-18	JBA



Copyright © 2018
 Vector Structural Engineering, LLC
 This drawing contains proprietary information belonging to Vector Structural Engineering, LLC and may be neither wholly nor partially copied or reproduced without the prior written permission of Vector Structural Engineering, LLC.

CIPRIAN MORAR / IMBUE DESIGN
RIDGE NEST 14 AT SUMMIT POWDER MOUNTAIN
 EDEN, UT
UPPER FOUNDATION & FRAMING PLANS

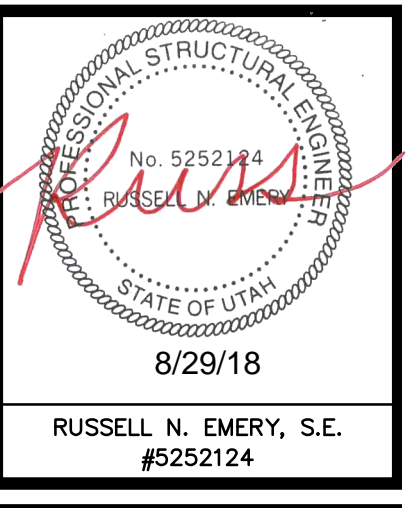

RUSSELL N. EMERY, S.E.
 #5252124

U2784-001-181

S3

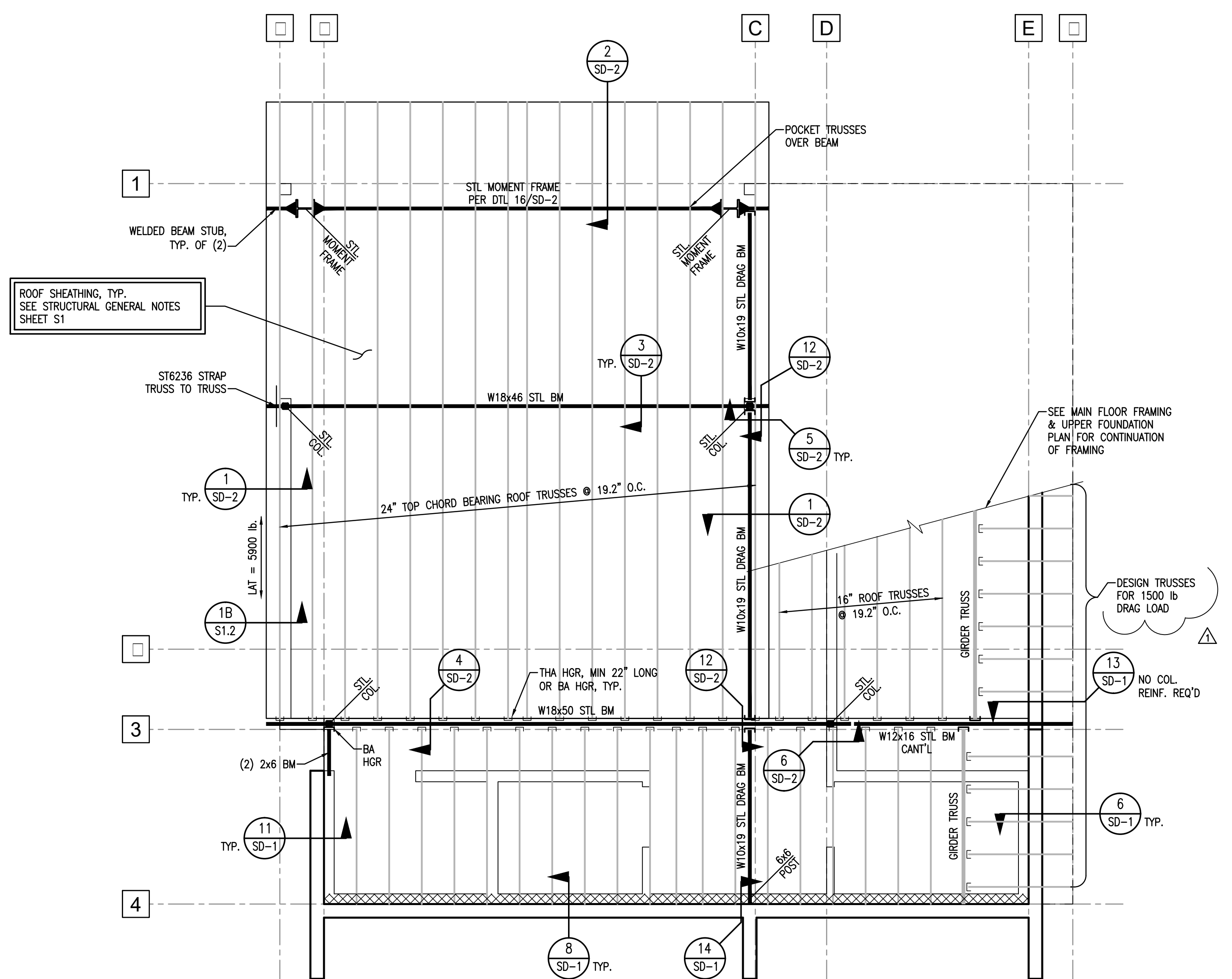

ROOF FRAMING PLAN

1/4" = 1'-0"

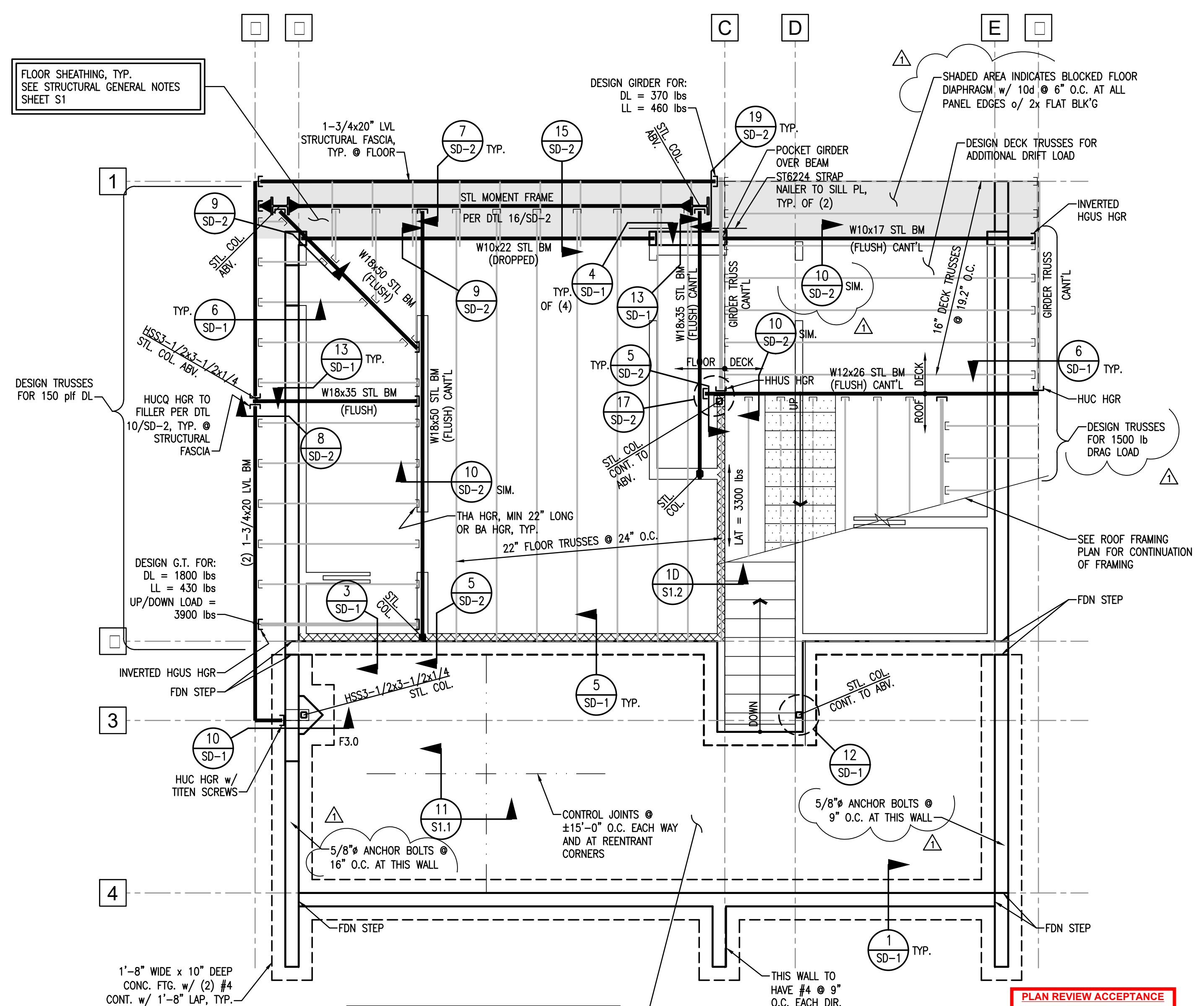

MAIN FLOOR FRAMING & UPPER FOUNDATION PLAN

1/4" = 1'-0"

PLAN REVIEW ACCEPTANCE
 FOR COMPLIANCE WITH THE APPLICABLE CONSTRUCTION CODES LISTED BELOW:

<input checked="" type="checkbox"/> BUILDING	<input checked="" type="checkbox"/> STRUCTURAL
<input checked="" type="checkbox"/> MECHANICAL	<input checked="" type="checkbox"/> PLUMBING
<input checked="" type="checkbox"/> ELECTRICAL	<input checked="" type="checkbox"/> ENERGY
<input checked="" type="checkbox"/> ACCESSIBILITY	<input checked="" type="checkbox"/> FIRE

PLAN REVIEW ACCEPTANCE OF DOCUMENTS DOES NOT AUTHORIZE CONSTRUCTION TO PROCEED IN VIOLATION OF ANY FEDERAL, STATE, OR LOCAL REGULATIONS.

MEM 09/12/18
 WEST COAST CODE CONSULTANTS, INC.

NOTE:
WHERE STRAP HOLDDOWN IS ATTACHED TO A SINGLE KINGSTUD & A SINGLE TRIMMER, ATTACH THE TWO TOGETHER w/ (2) 16d SINKERS @ 6" O.C. FULL HEIGHT OR w/ LTP4 @ 12" O.C. FULL HEIGHT.

NOTE:
SHEAR WALL SHEATHING MAY BE ON EITHER SIDE OF INDICATED WALL.

NOTE:
INSTALL CS16 STRAPS TO 2x STUDS ABOVE AND BELOW FLOOR FRAMING. NAIL EACH END w/ (11) 10d NAILS. (STRAP LENGTH = 48"). WHERE WALL DOES NOT OCCUR BELOW, ATTACH TO BEAM OR TRUSS

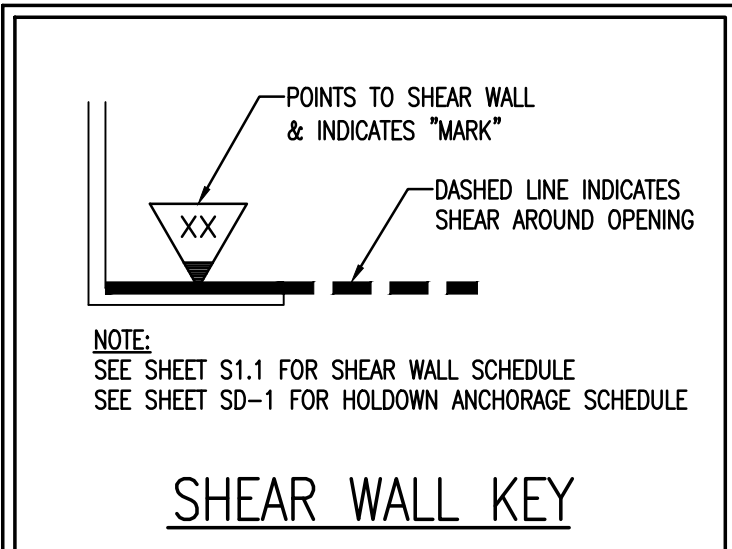

DATE	REV. #	DATE	BY	DESCRIPTION
07/12/18				



Copyright © 2018
Vector Structural Engineering, LLC
This drawing contains proprietary information belonging to Vector Structural Engineering, LLC and may be neither wholly nor partially copied or reproduced without the prior written permission of Vector Structural Engineering, LLC.

CIPRIAN MORAR / IMBUE DESIGN
RIDGE NEST 14 AT SUMMIT POWDER MOUNTAIN
EDEN, UT
SHEAR WALL PLANS

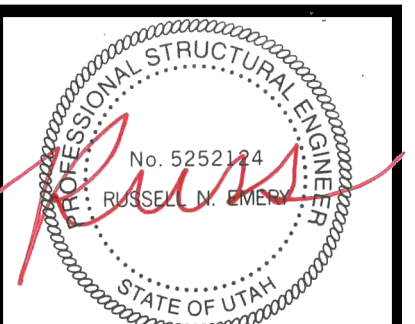

8/29/18
RUSSELL N. EMERY, S.E.
#5252124

U2784-001-181

S4

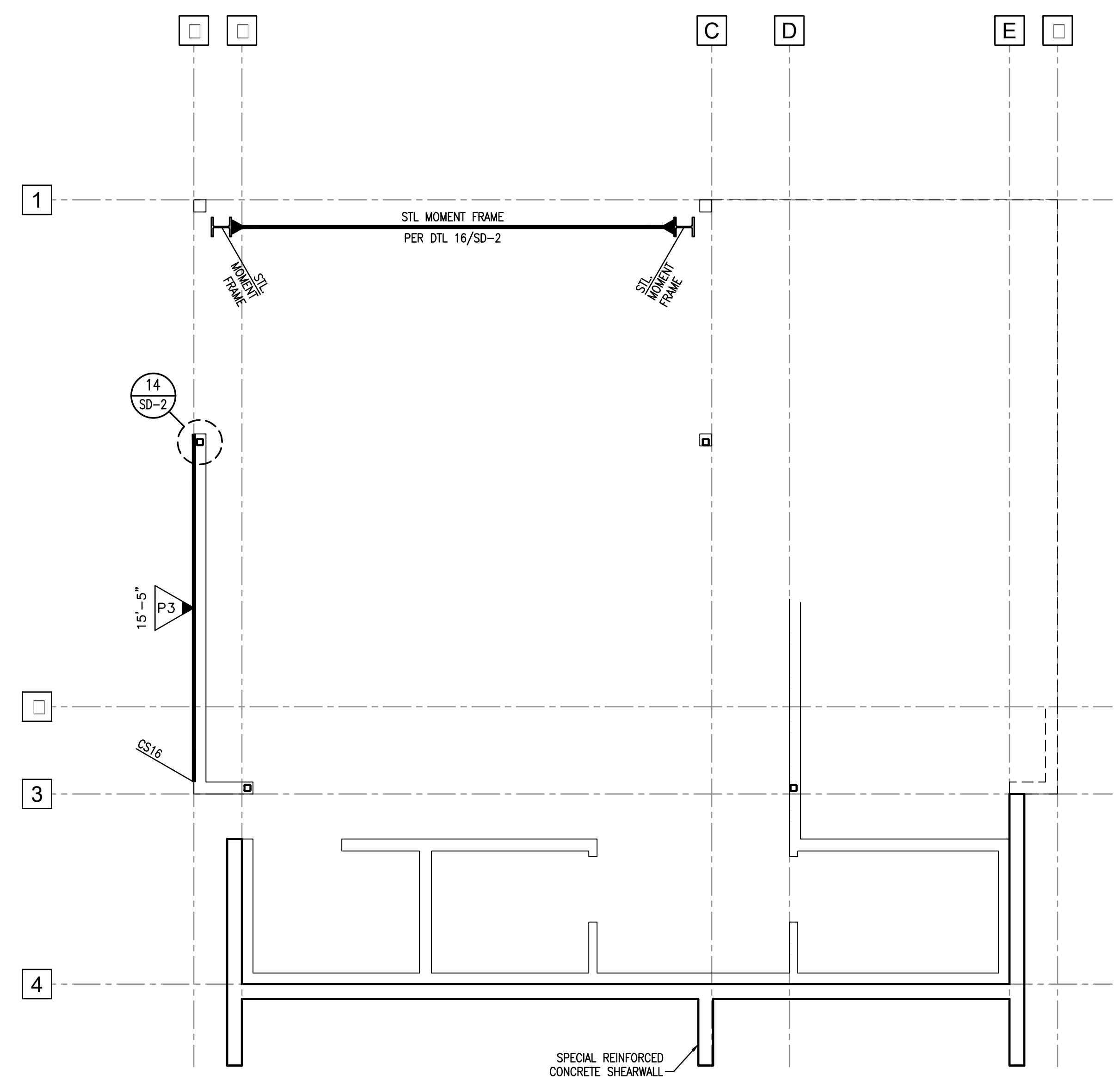

UPPER LEVEL SHEAR WALL PLAN

1/4" = 1'-0"

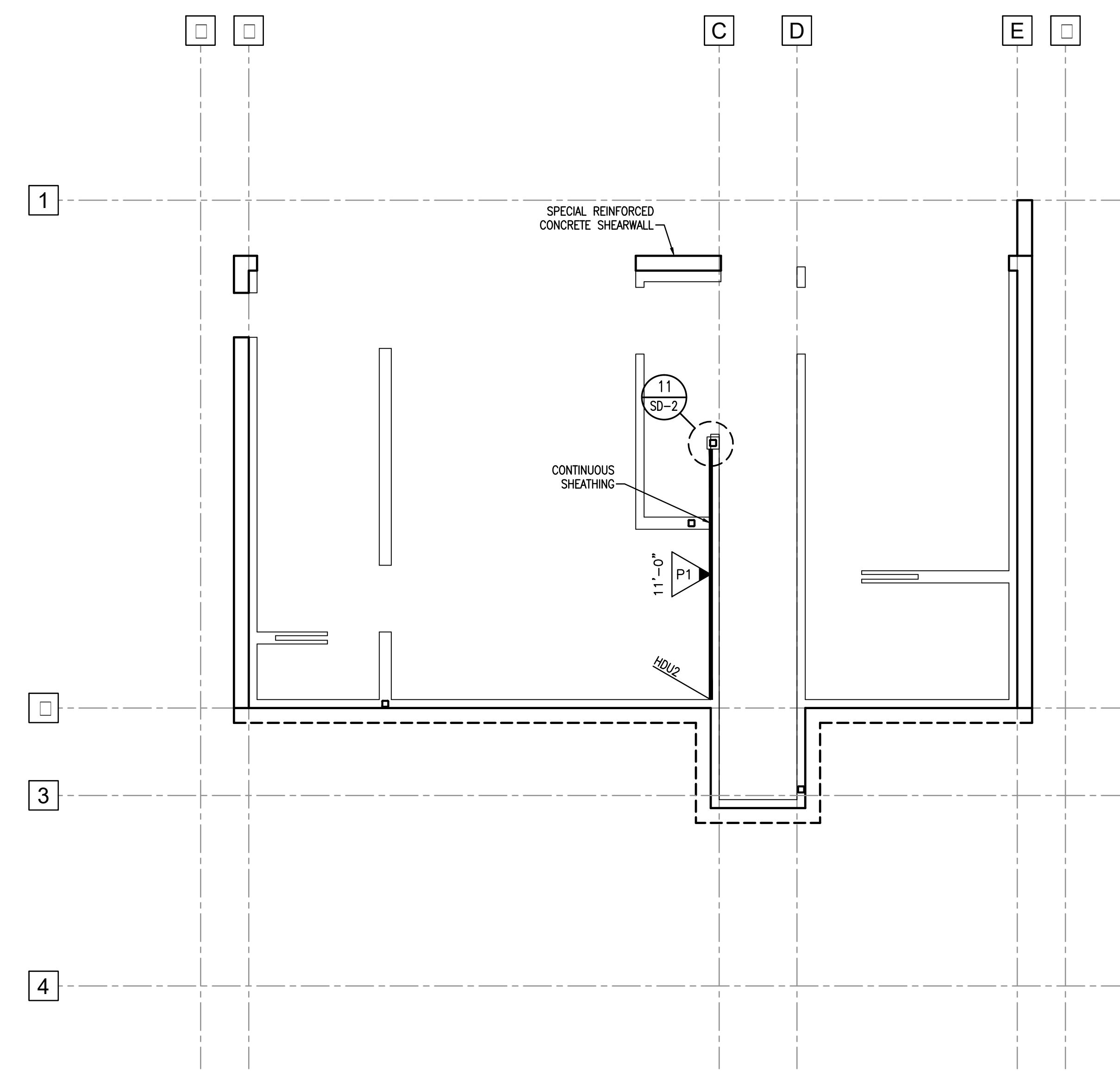

LOWER LEVEL SHEAR WALL PLAN

1/4" = 1'-0"

PLAN REVIEW ACCEPTANCE
FOR COMPLIANCE WITH THE APPLICABLE CONSTRUCTION CODES IDENTIFIED BELOW

<input checked="" type="checkbox"/> BUILDING	<input checked="" type="checkbox"/> STRUCTURAL
<input checked="" type="checkbox"/> MECHANICAL	<input checked="" type="checkbox"/> PLUMBING
<input checked="" type="checkbox"/> ELECTRICAL	<input checked="" type="checkbox"/> ENERGY
<input type="checkbox"/> ACCESSIBILITY	<input type="checkbox"/> FIRE

PLAN REVIEW ACCEPTANCE OF DOCUMENTS DOES NOT AUTHORIZE CONSTRUCTION TO PROCEED IN VIOLATION OF ANY FEDERAL, STATE, OR LOCAL REGULATIONS.

BY: **MEM** DATE: 08/12/18
WEST COAST CODE CONSULTANTS, INC.

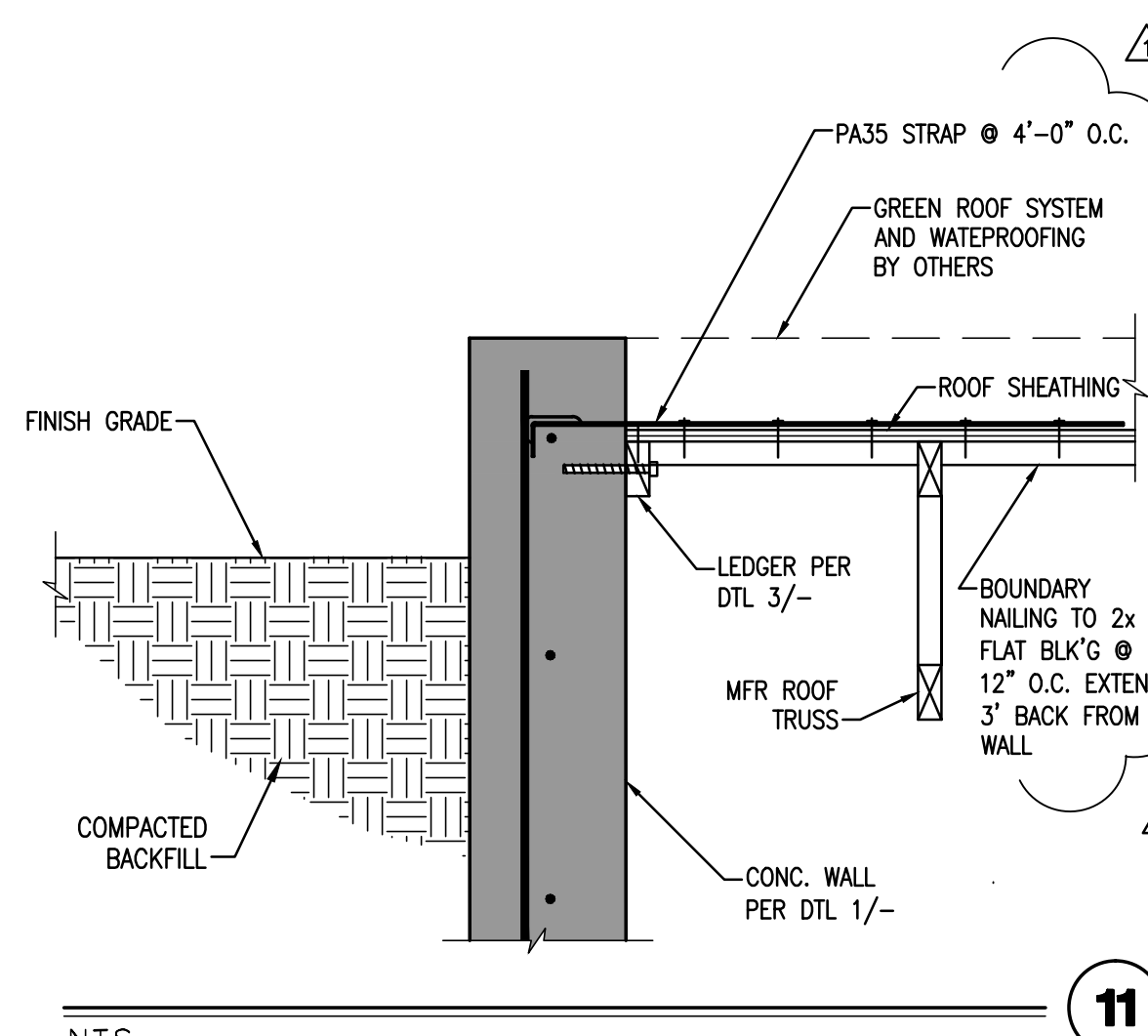

N.T.S.

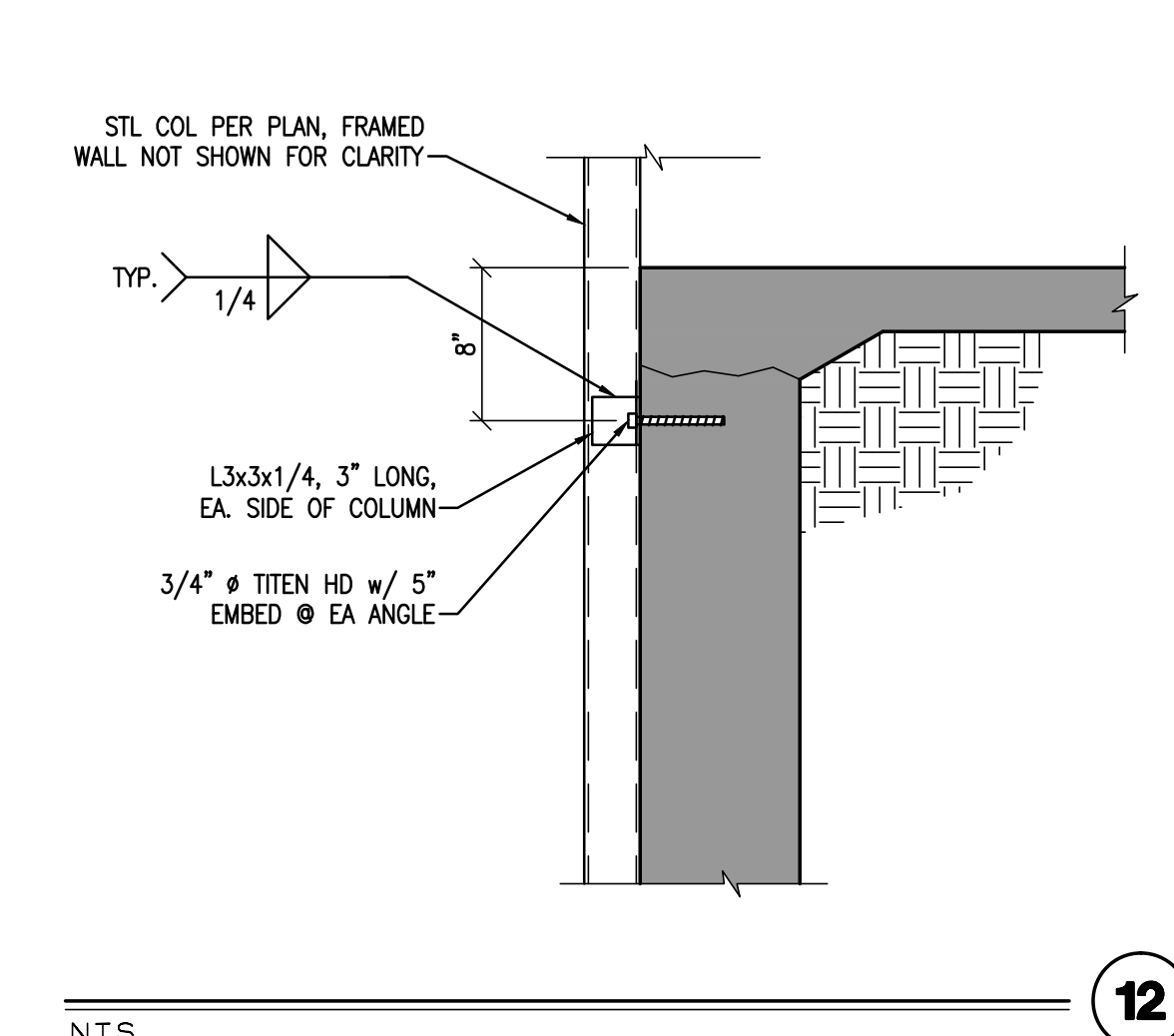

N.T.S.

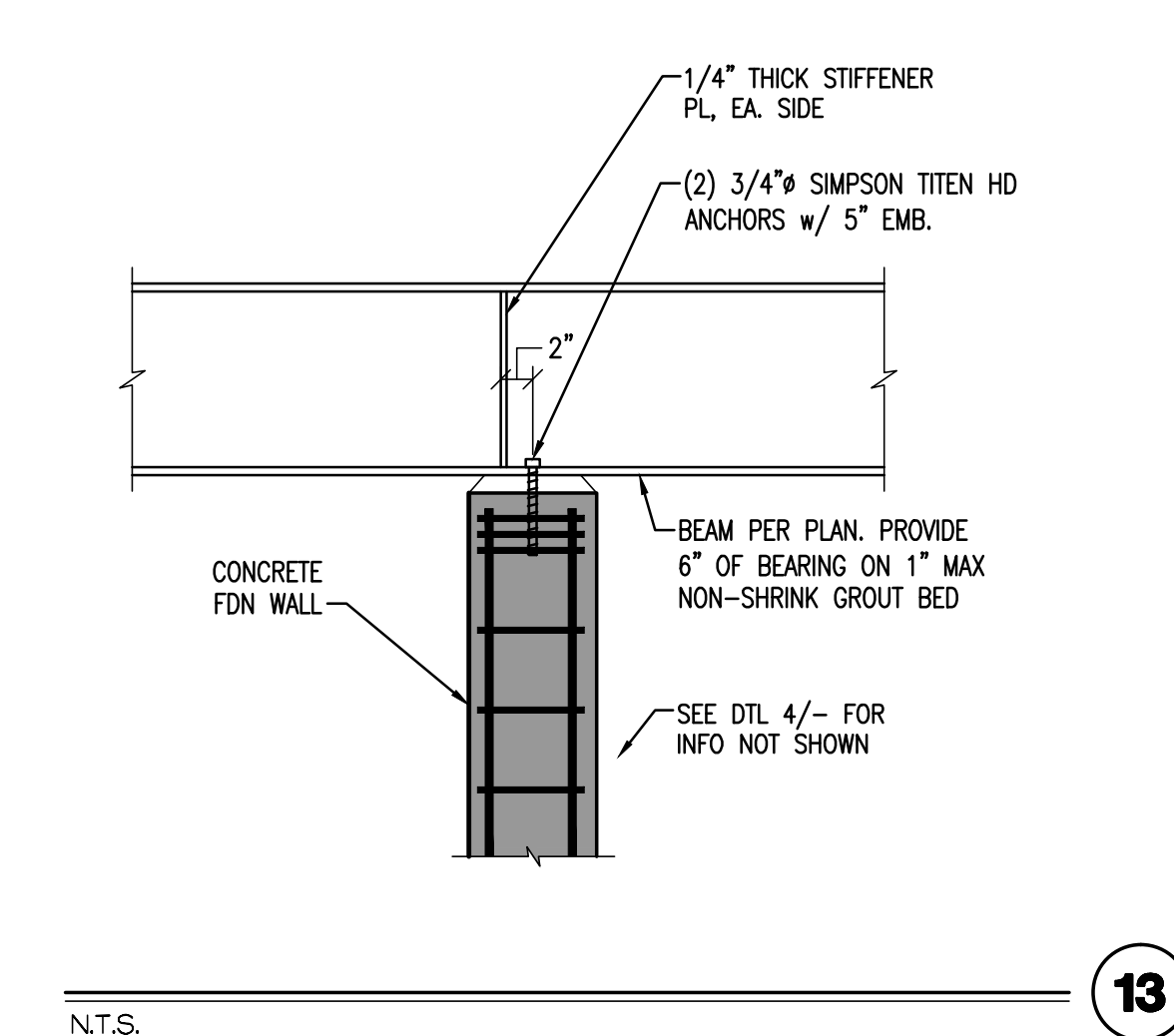

N.T.S.

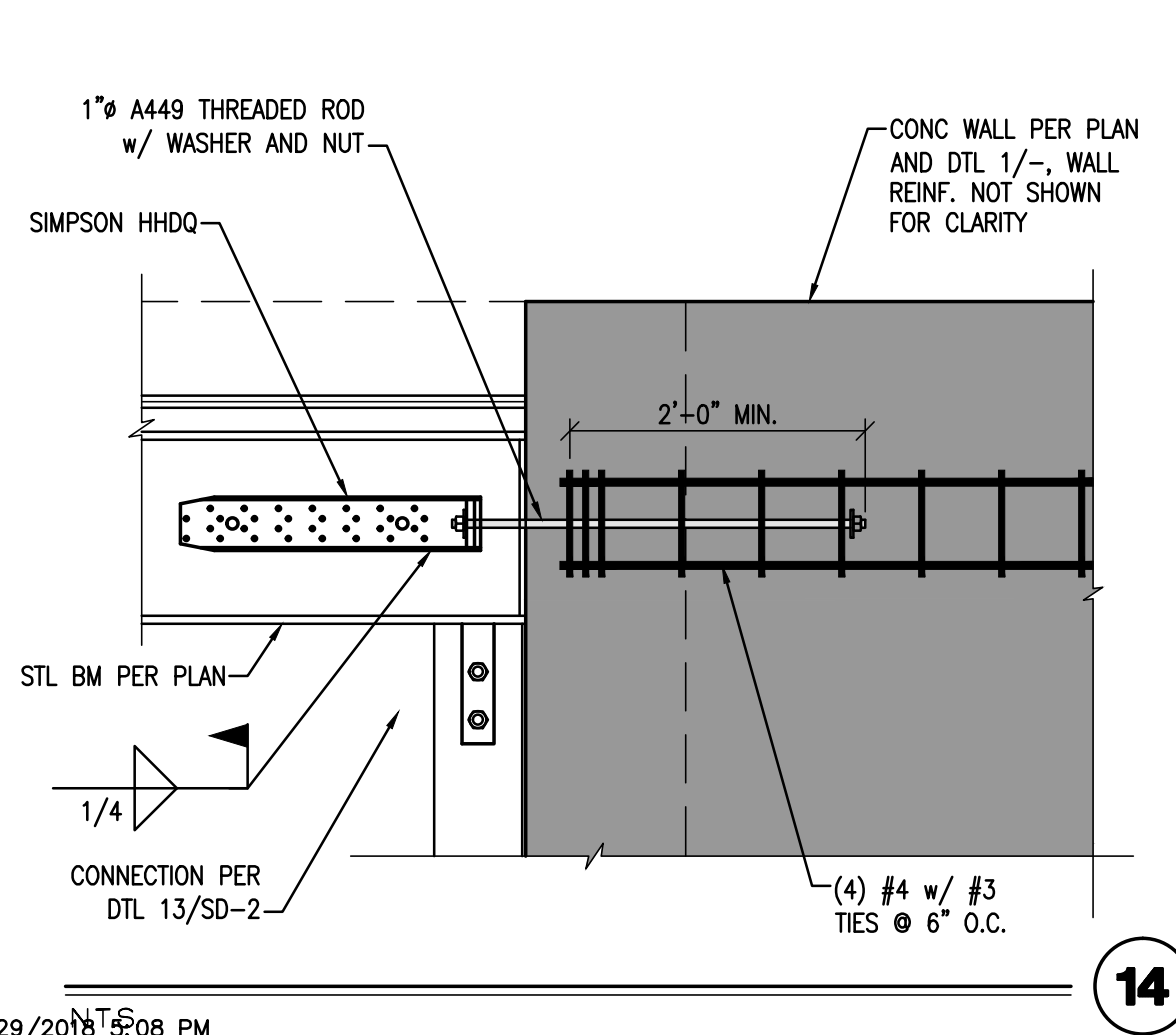

8/29/2018 5:08 PM

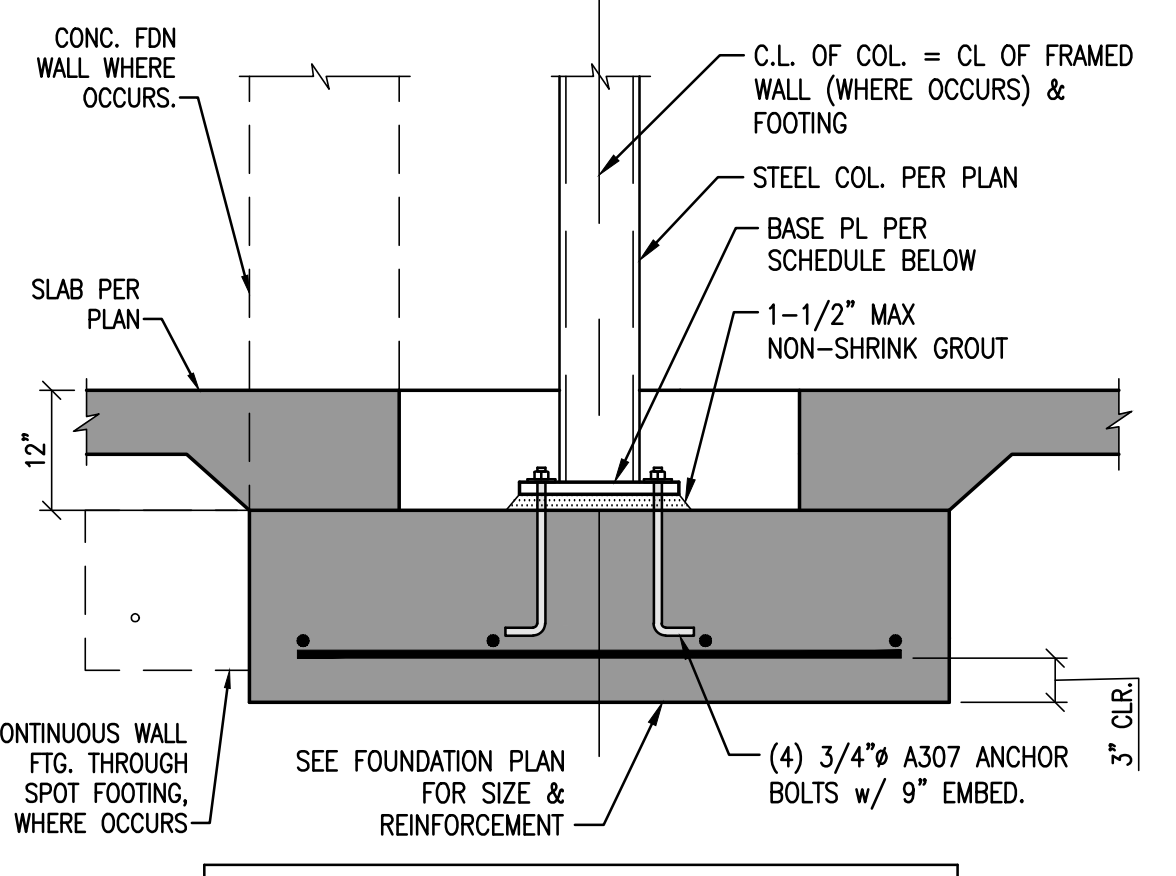
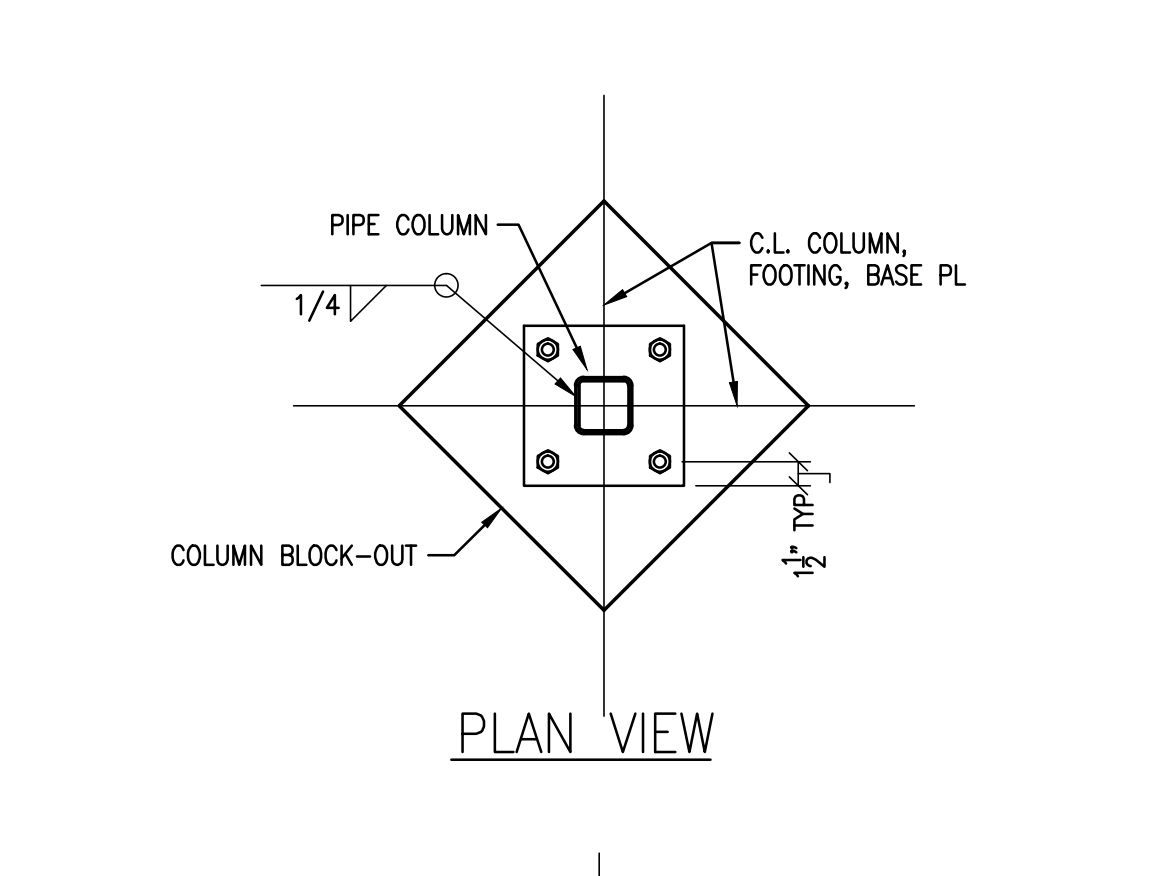

BASE PLATE SCHEDULE	
COLUMN SIZE	BASE PLATE
3", 3-1/2" OR 4" HSS COL.	10"x10"x3/4" PLATE
5" OR 6" HSS COL.	12"x12"x3/4" PLATE

N.T.S.

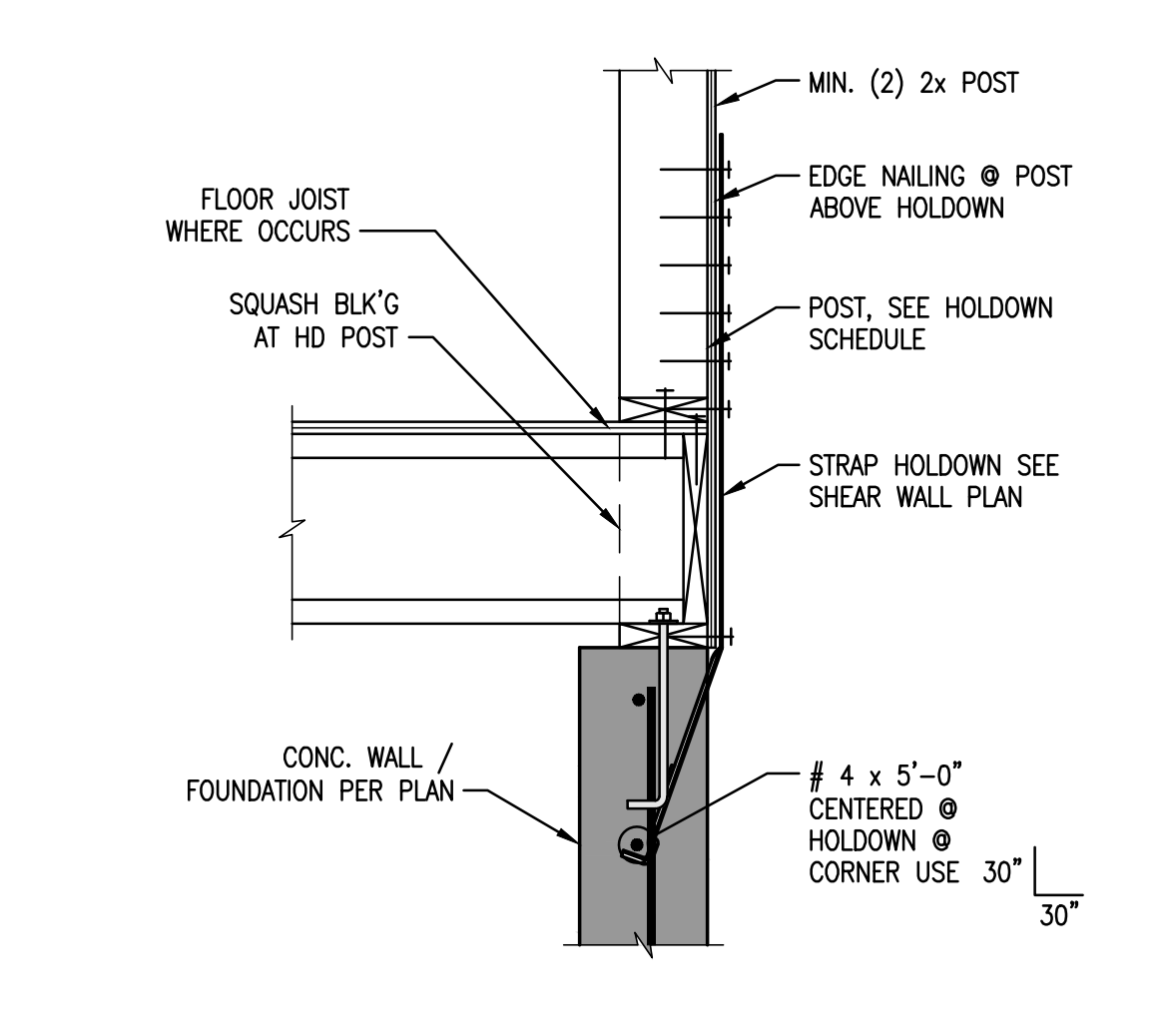

N.T.S.

ANCHORAGE						
	ANCHORAGE (CAST IN PLACE)			ANCHORAGE (RETROFIT)		
HOLDOWN	SSTB	ALL THREAD ROD (NOTE 1)	ALL THREAD ROD (NOTE 2 & 3)	HOLE DIAMETER	EMBEDMENT	POST
HU2 - SDS2.5	SSTB24	5/8" A307	5/8" A307	3/4"	10"	(2) 2x
HU4 - SDS2.5	SSTB24	5/8" A307	5/8" A307	3/4"	10"	(2) 2x
HU5 - SDS2.5	NONE	5/8" A307	5/8" A307	3/4"	13"	(2) 2x
HU8 - SDS2.5	NONE	7/8" A307	7/8" A307	1"	18"	(3) 2x

NOTES:
 1. PROVIDE 2-1/8"x2-1/8"x3/8" STEEL PLATE w/ (2) NUTS @ CAST IN PLACE ANCHORS.
 2. RETROFIT ALL-THREAD ROD IN HOLES w/ SIMPSON SET-XP EPOXY. PREPARE HOLES & INSTALL EPOXY PER MFR DIRECTIONS w/ EMBEDMENT AND EDGE DISTANCES AS SHOWN.
 3. SIMPSON SET-XP EPOXY PER ICC-ES 2508.
 4. INCREASE FOOTING DEPTH AS REQUIRED FOR 3" MIN. COVER BELOW BOLT & COORDINATE EXACT LOCATIONS WITH THE FRAMING CONTRACTOR.
 5. HOLDOWNS MAY BE INSTALLED 4" MAX. FROM SHEAR WALL EDGE. BOUNDARY NAILING MUST BE PROVIDED @ STUDS ALIGNED WITH HOLDOWNS.
 6. SEE DETAIL 9/S1.1 FOR INTERIOR HDU HOLDOWN ANCHORAGE AND CONCRETE COVER REQUIREMENTS.

N.T.S.

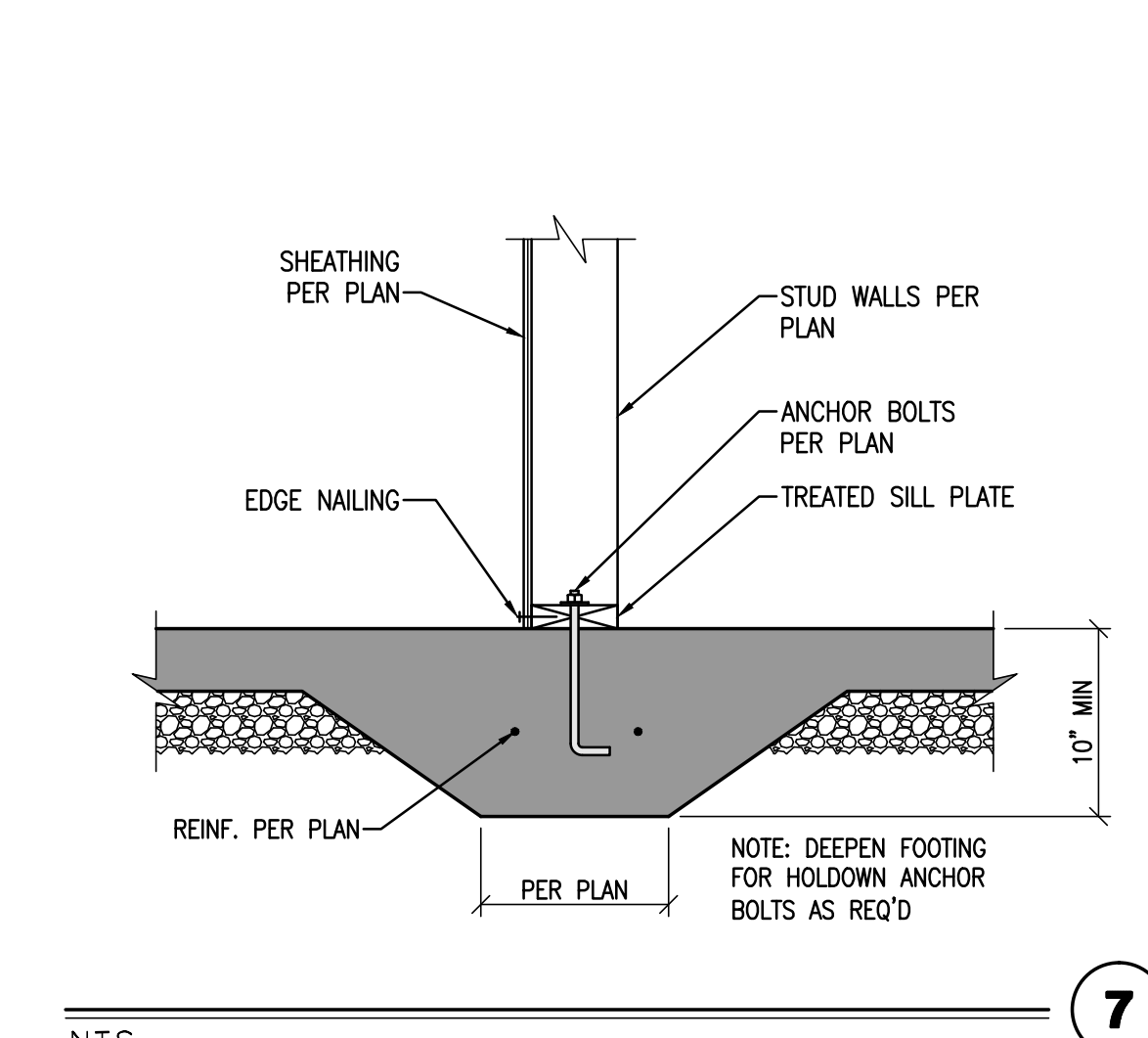

N.T.S.

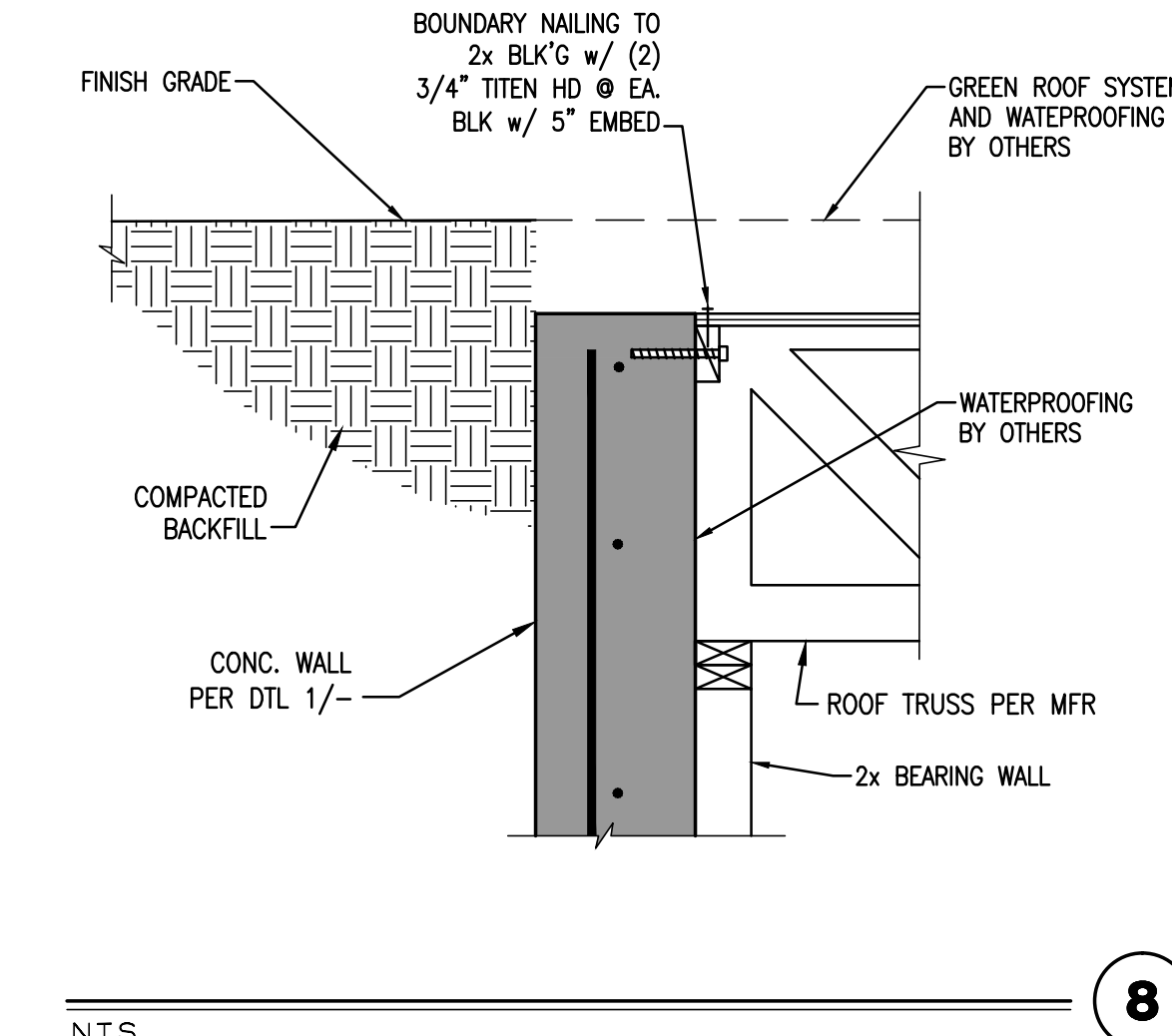

N.T.S.

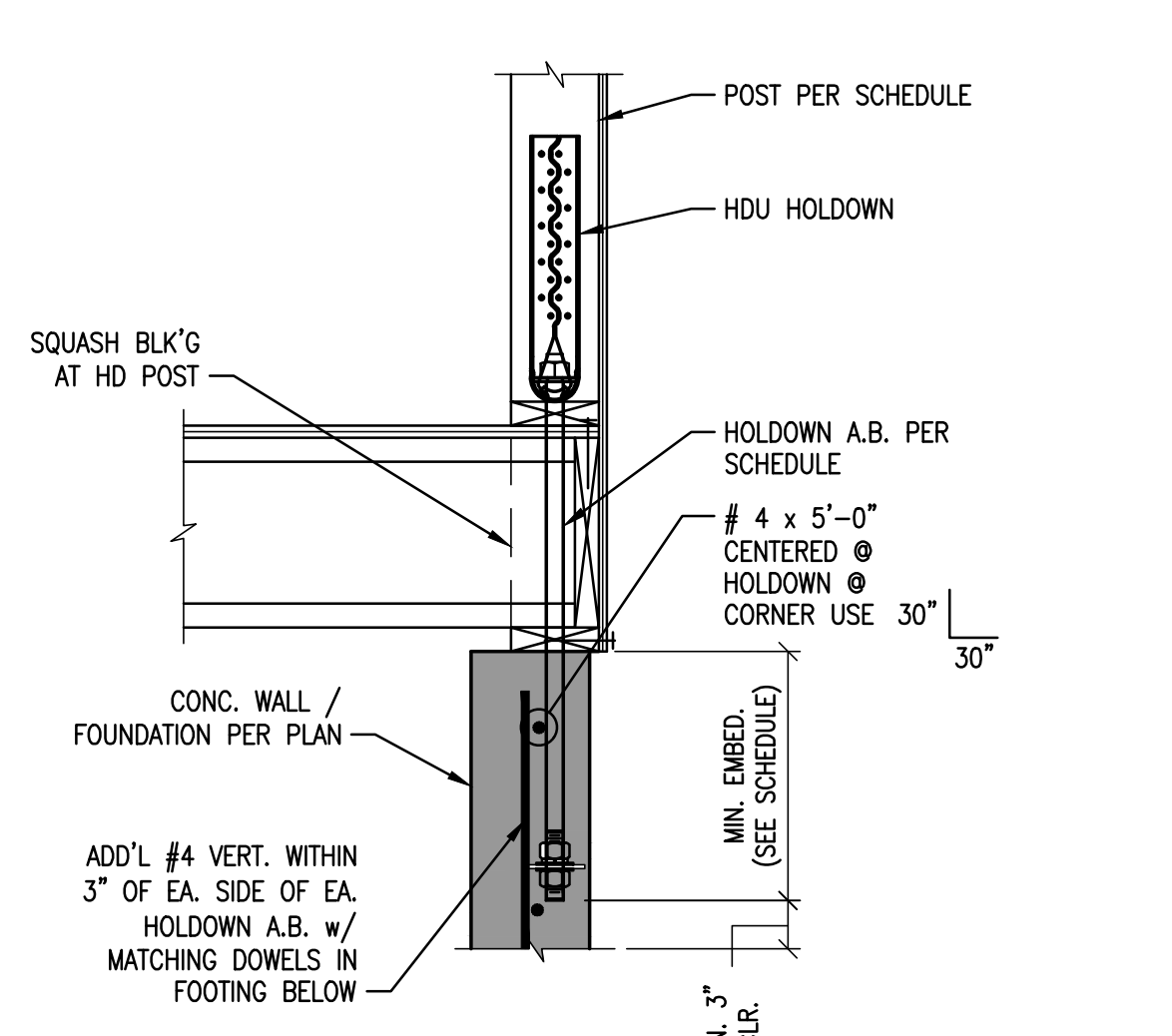

N.T.S.

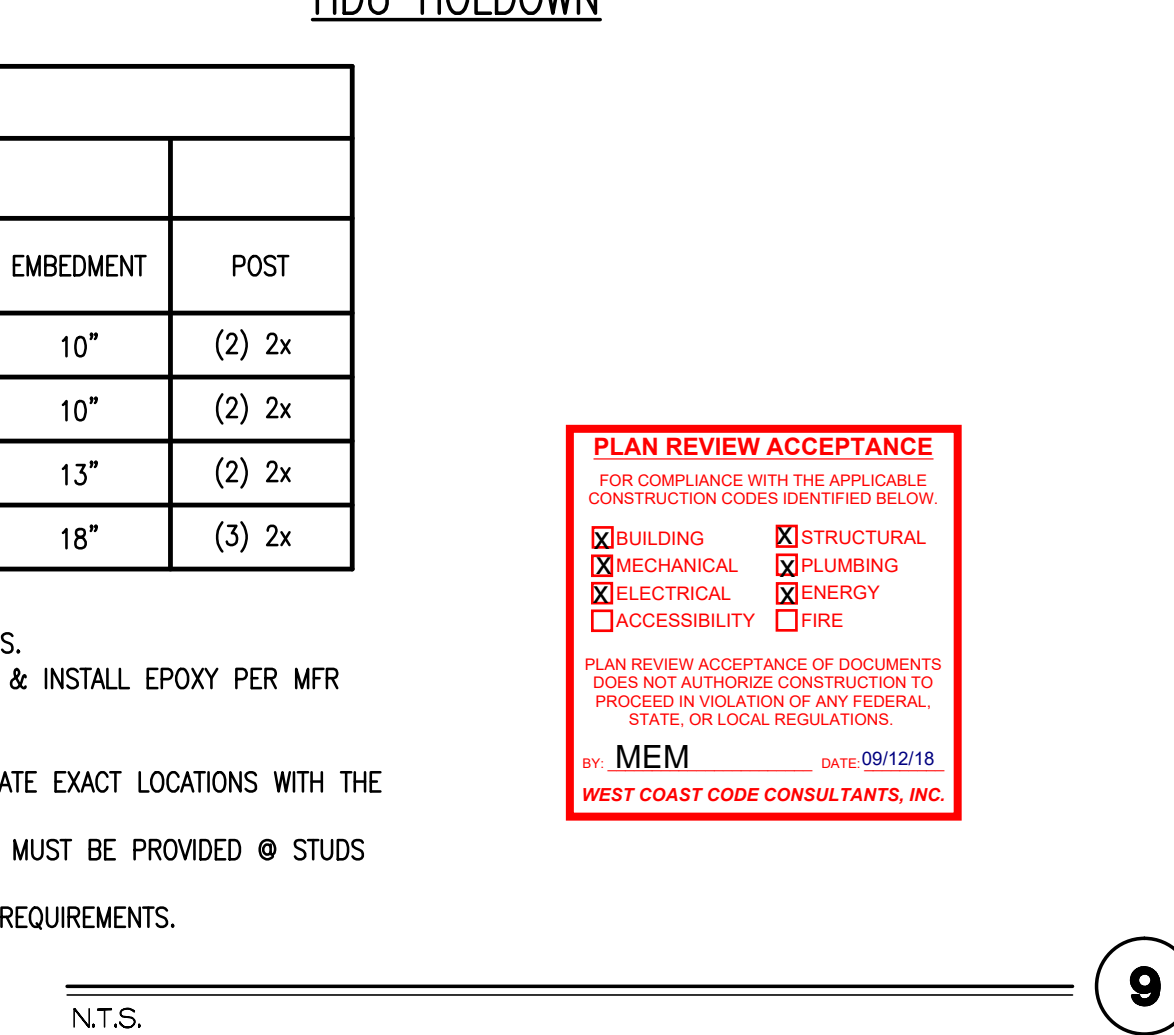

N.T.S.

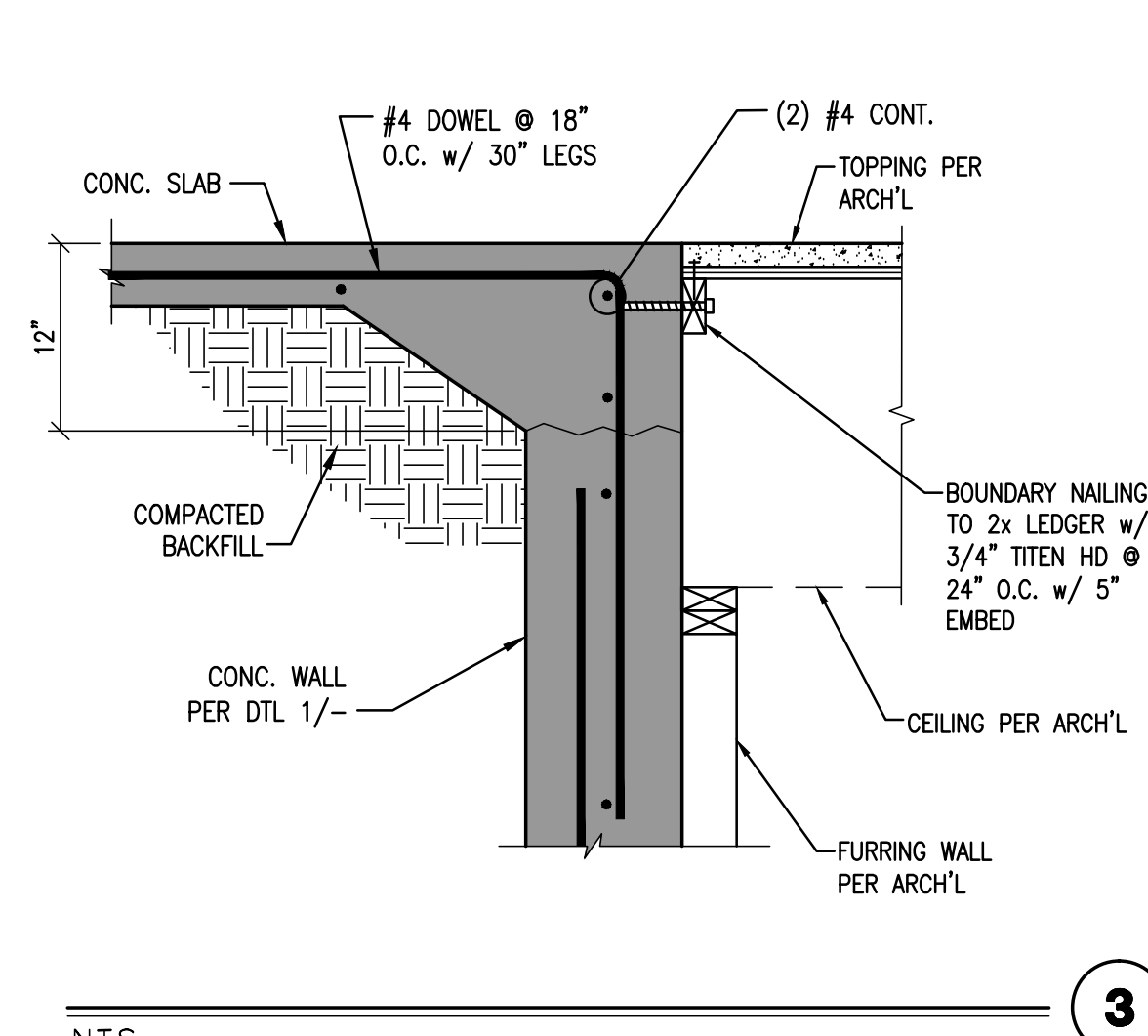

N.T.S.

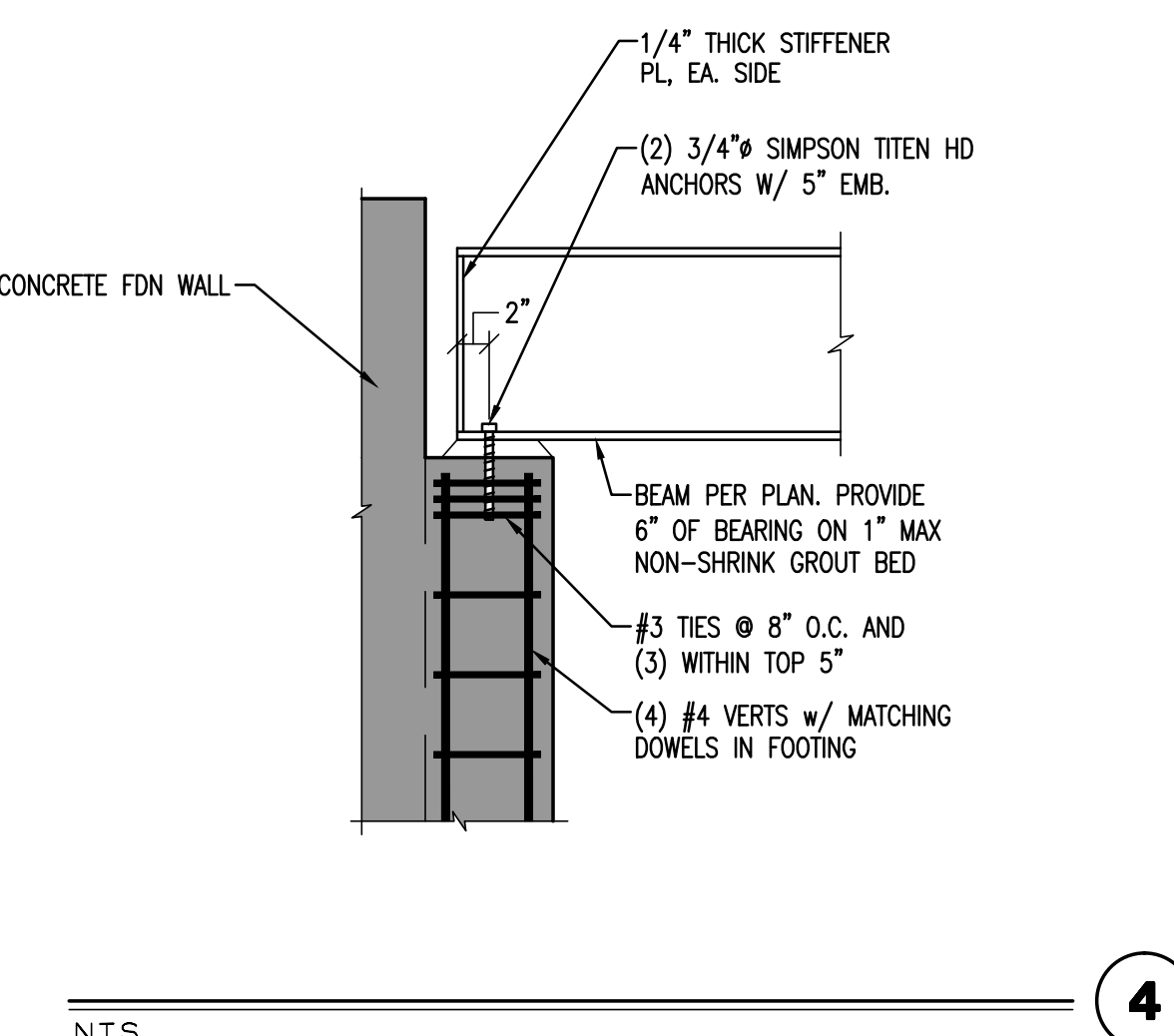

N.T.S.

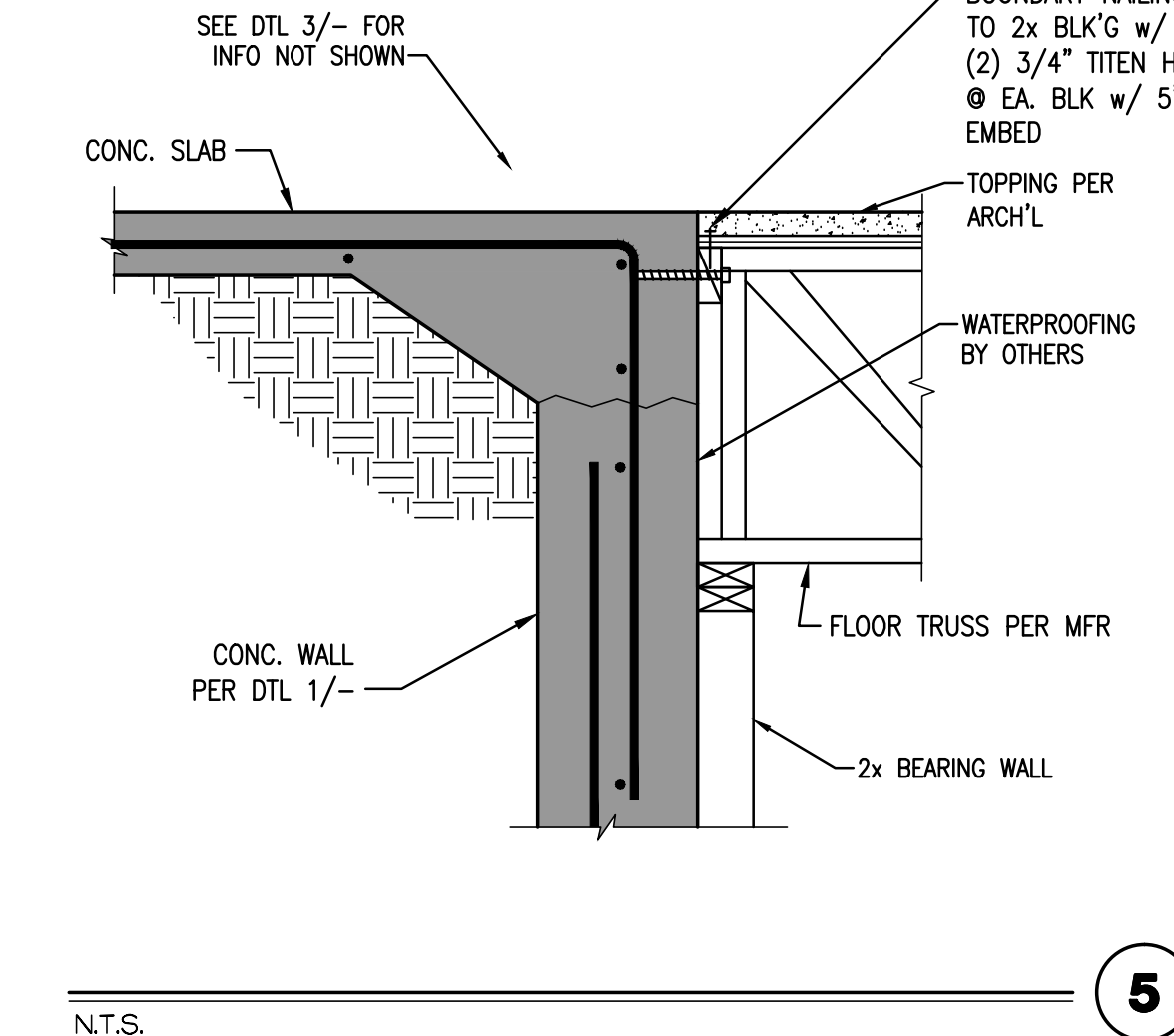

N.T.S.

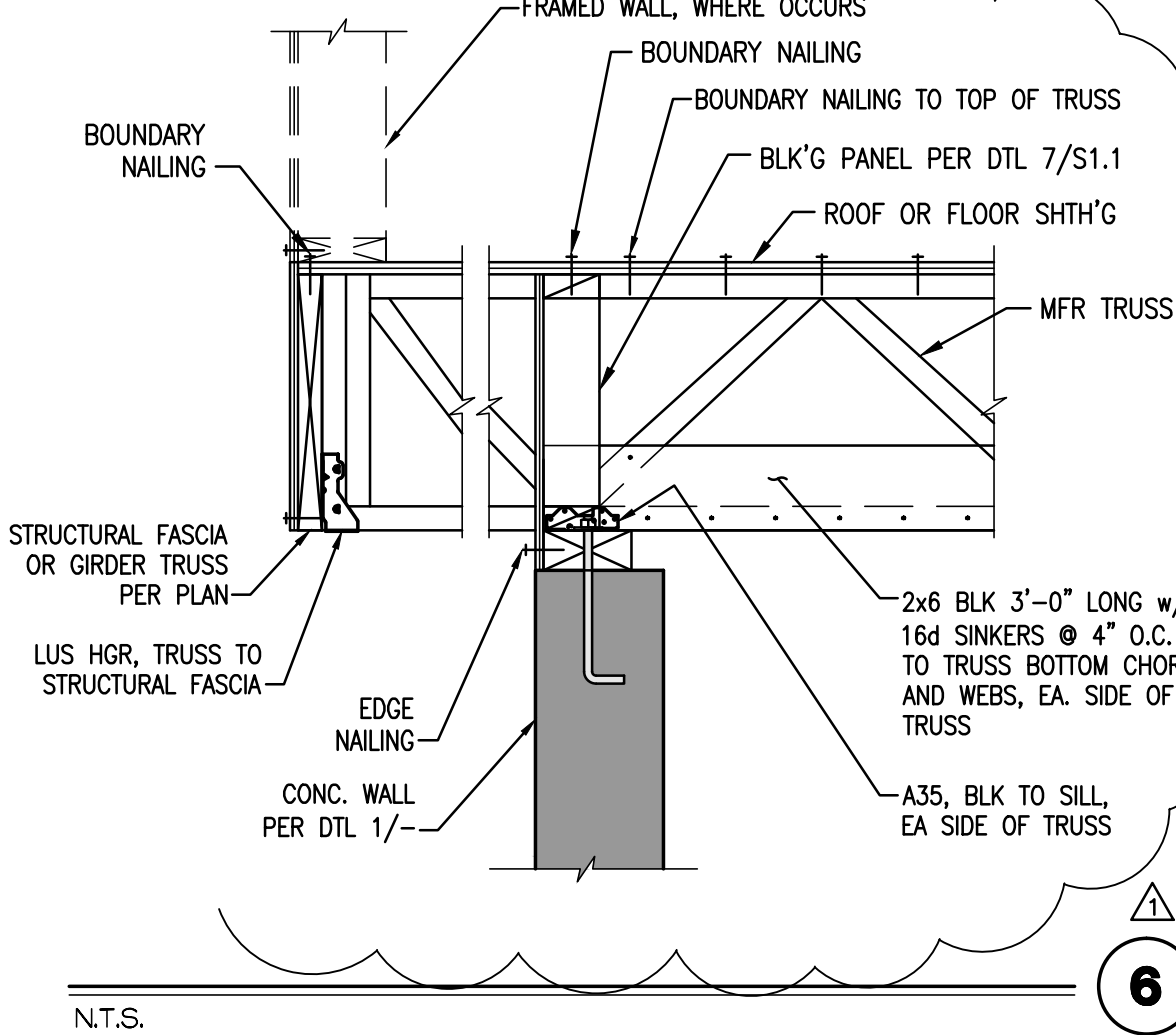

N.T.S.

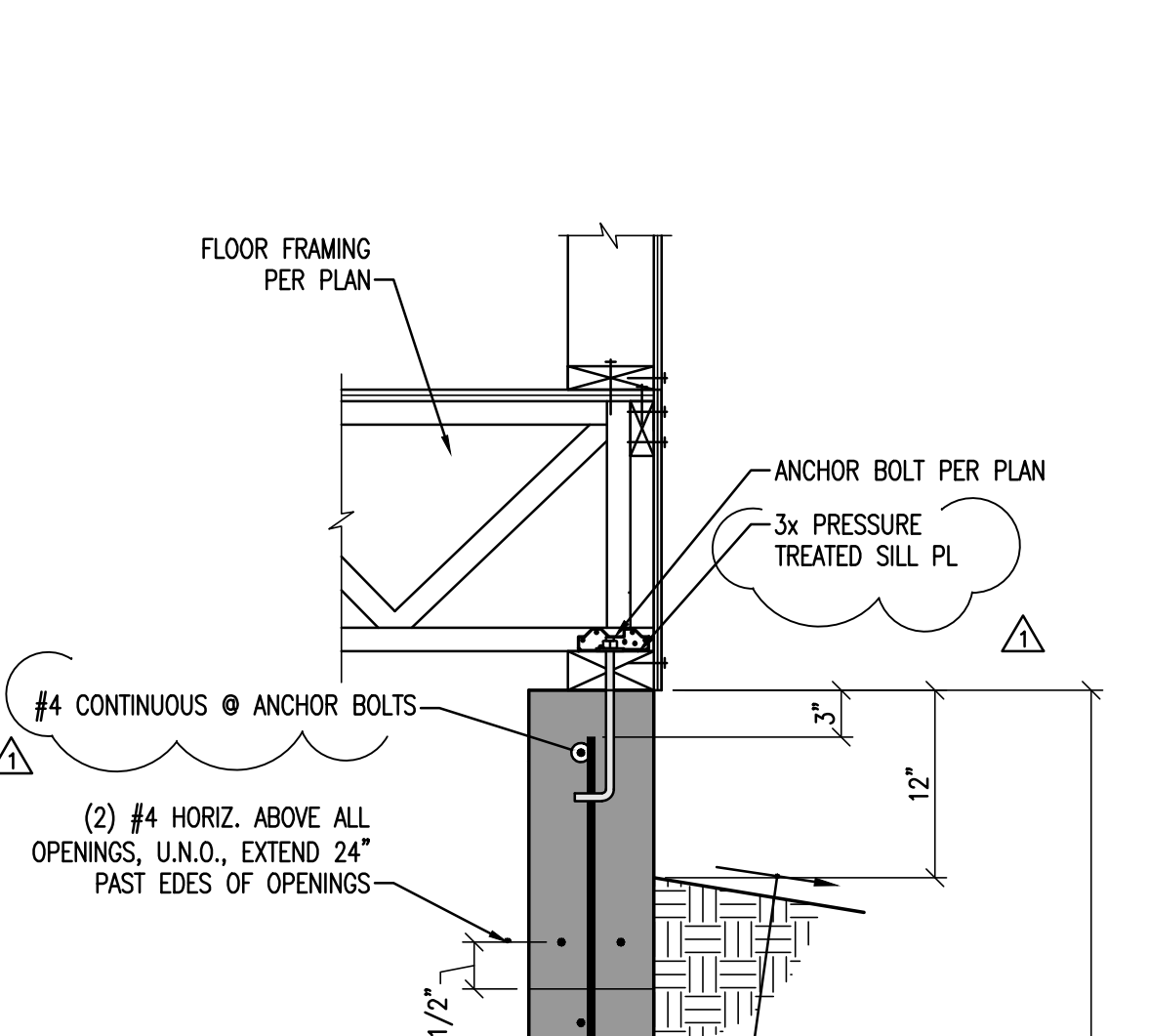

N.T.S.

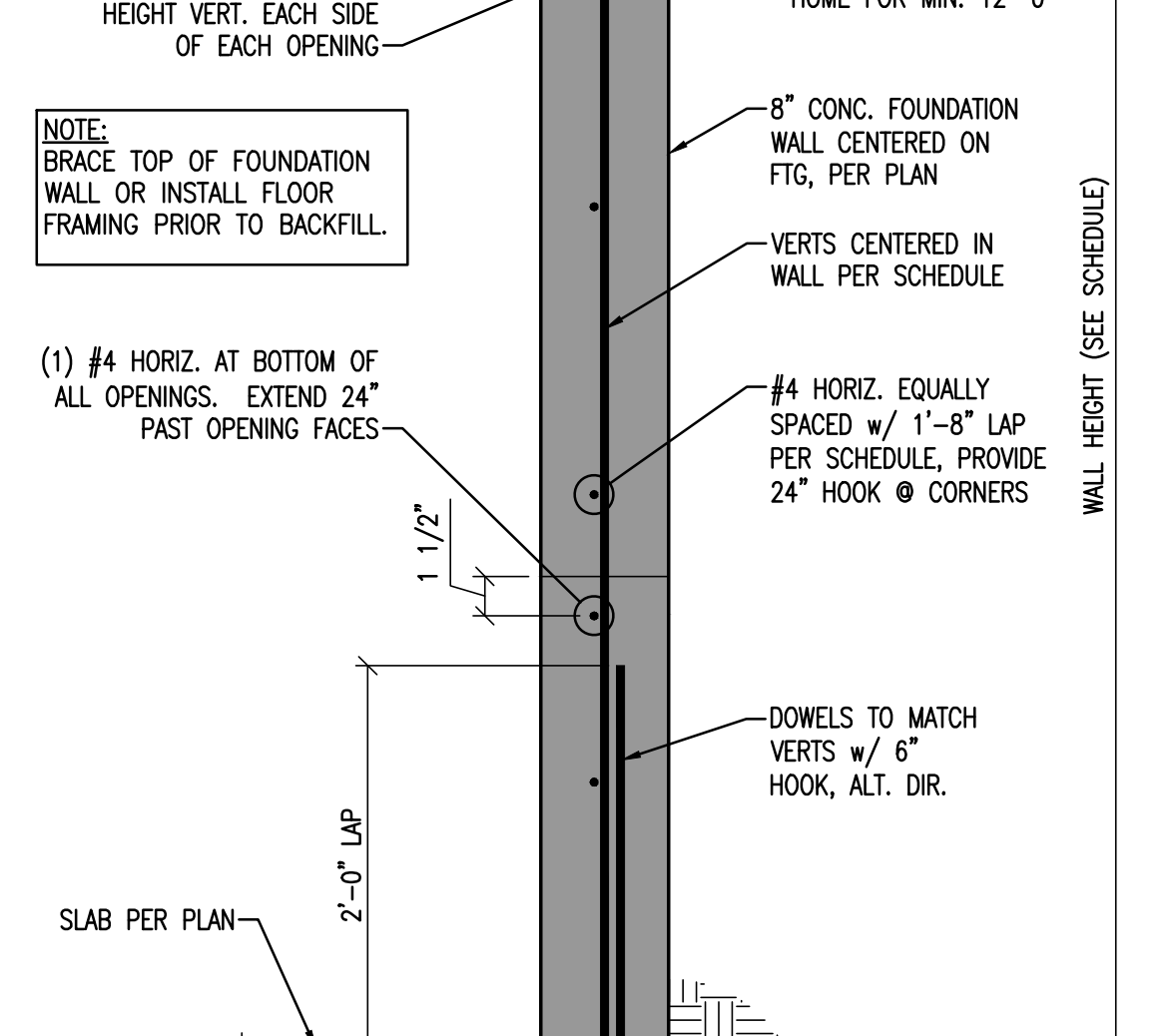

N.T.S.

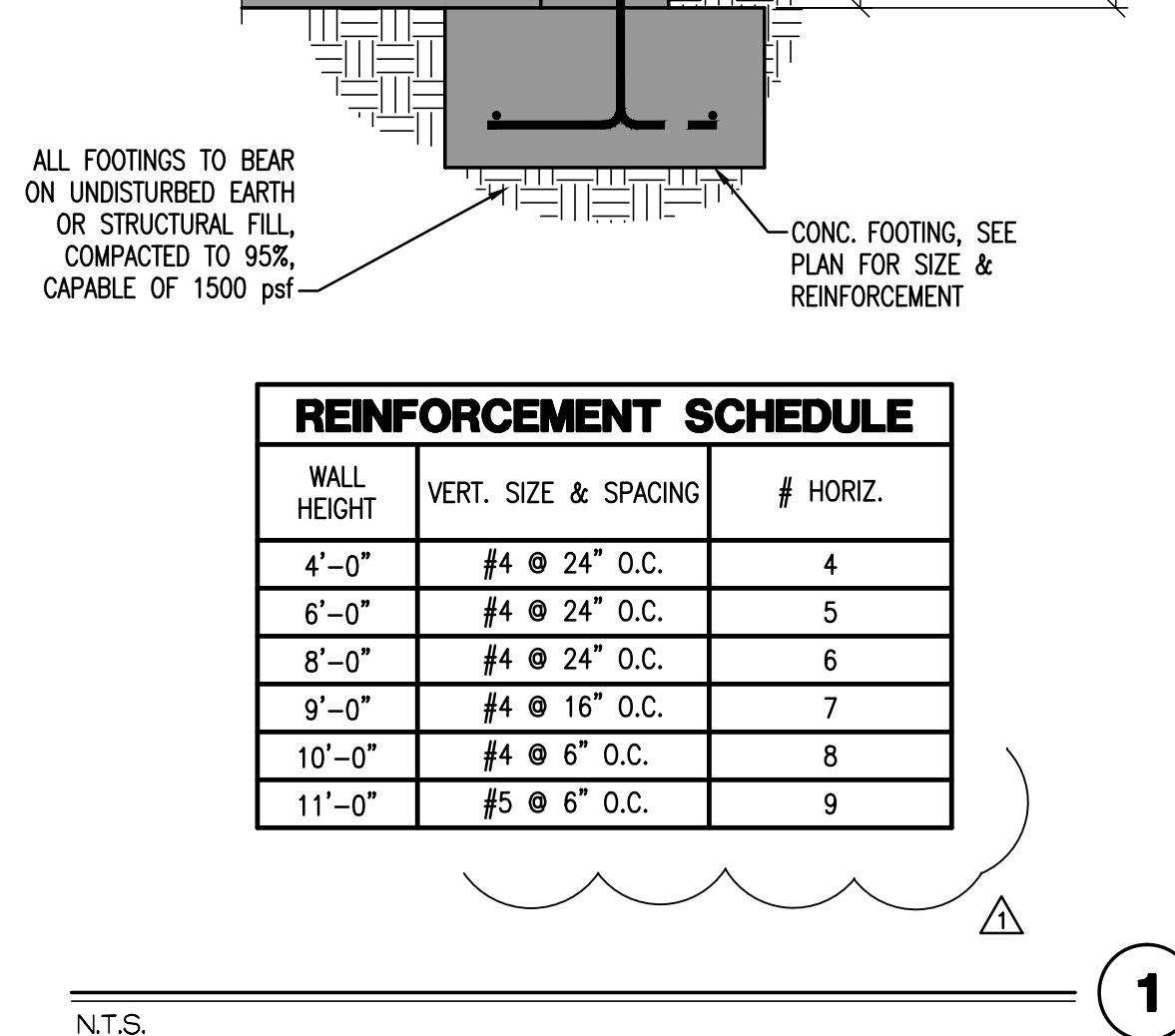

N.T.S.

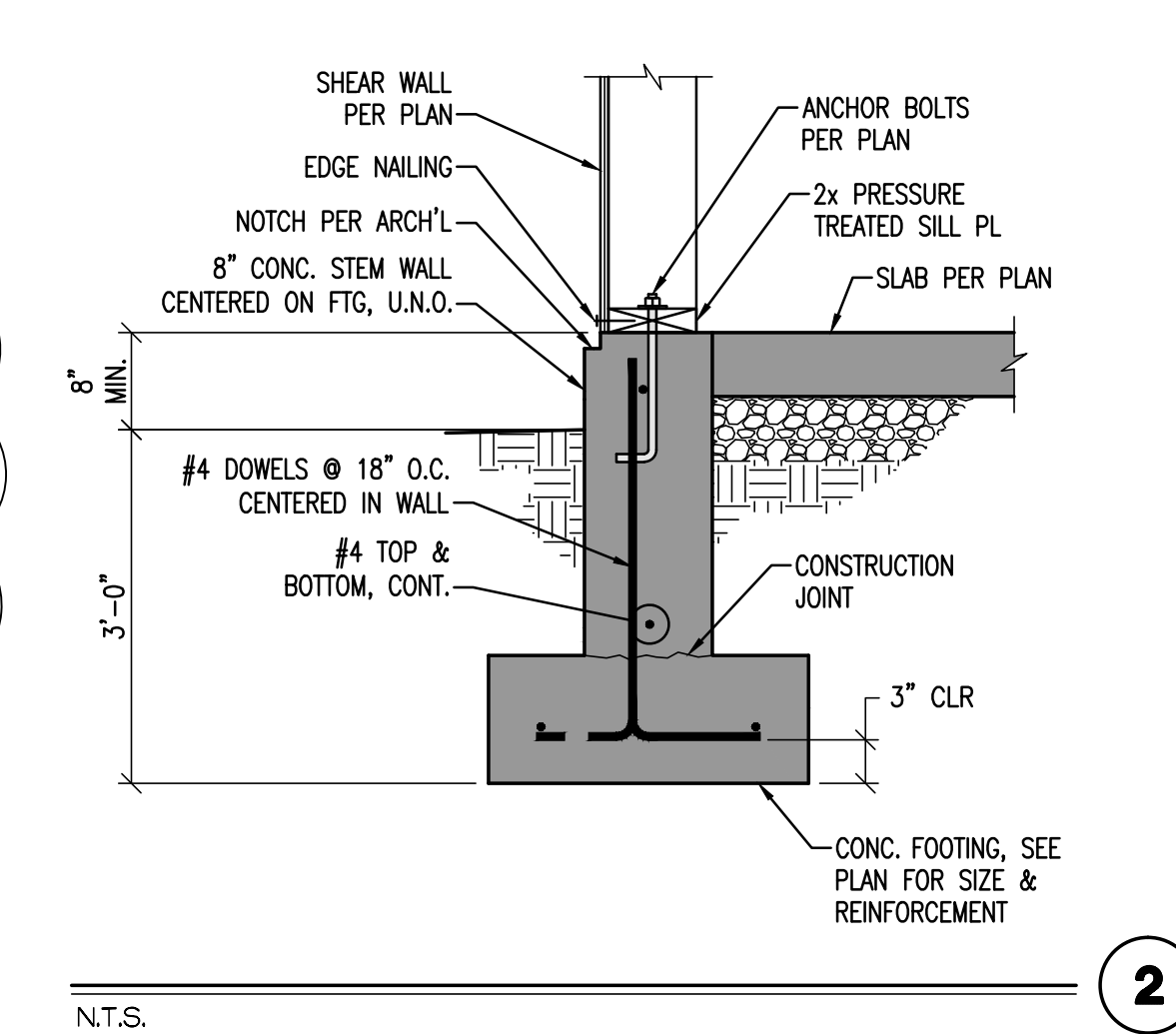

N.T.S.

REINFORCEMENT SCHEDULE		
WALL HEIGHT	VERT. SIZE & SPACING	# HORIZ.
4'-0"	#4 @ 24" O.C.	4
6'-0"	#4 @ 24" O.C.	5
8'-0"	#4 @ 24" O.C.	6
9'-0"	#4 @ 16" O.C.	7
10'-0"	#4 @ 6" O.C.	8
11'-0"	#5 @ 6" O.C.	9

DATE: 07/12/18	ENG: JBA	CHK: RNE
REV #	DATE	DESCRIPTION
1	08-28-18	JBA AS SHOWN

VECTOR ENGINEERS
 DRAPER, UTAH
 (801) 990-1775
 WWW.VECTORSE.COM

Copyright © 2018
 Vector Structural Engineering, LLC
 This drawing contains proprietary information belonging to Vector Structural Engineering, LLC and may be neither wholly nor partially copied or reproduced without the prior written permission of Vector Structural Engineering, LLC.

CIPRIAN MORAR / IMBUE DESIGN
RIDGE NEST 14 AT SUMMIT POWDER MOUNTAIN
 EDEN, UT

FOUNDATION DETAILS

PROFESSIONAL STRUCTURAL ENGINEER
 No. 5252124
 RUSSELL N. EMERY, S.E.
 #5252124
 8/29/18

U2784-001-181

SD-1

