



Feb 26, 2019

To: Kevin Garside
Advanced Shoring & Underpinning Inc.

Re: Engineering Submittal – Micro Piles / Deep Foundations
Lot 44 Powder Mountain Resort
8645 East Copper Crest Drive
Eden, UT

PLAN REVIEW ACCEPTANCE	
FOR COMPLIANCE WITH THE APPLICABLE CONSTRUCTION CODES IDENTIFIED BELOW.	
<input checked="" type="checkbox"/> BUILDING	<input checked="" type="checkbox"/> STRUCTURAL
<input checked="" type="checkbox"/> MECHANICAL	<input checked="" type="checkbox"/> PLUMBING
<input checked="" type="checkbox"/> ELECTRICAL	<input checked="" type="checkbox"/> ENERGY
<input type="checkbox"/> ACCESSIBILITY	<input type="checkbox"/> FIRE
PLAN REVIEW ACCEPTANCE OF DOCUMENTS DOES NOT AUTHORIZE CONSTRUCTION TO PROCEED IN VIOLATION OF ANY FEDERAL, STATE, OR LOCAL REGULATIONS.	
BY: MEM	DATE: 03/04/19
WEST COAST CODE CONSULTANTS, INC.	

Mr. Garside,

This report details the design of micro piles / deep foundations at the project mentioned above.

General

The project consists of a constructing a new residential house along the south side of Copper Crest and installing a deep foundation system for foundations P1 through P10. This report details the engineering and design for installing micropiles along gridline B from 2.9 to 6.5 along gridline 4 from D to H along gridline D from 1.9 to 2.1 at approximately gridline 1.8 from E.8 to H and along gridline I from 6.5 to 9.8. for the purpose of supporting vertical and some lateral loading.

Foundation Loads

Foundation loads for the support of the footings have been provided by the structural engineers Nous Engineering. These design loads are up to 460 kips in compression with no tension loading and up to 40 kip in lateral loads.

Soil Conditions

Based on the available soils report by IGES dated March 19, 2018. Soils consist of up to 5 feet of clayey sand fill above with up to 2 feet of sandy clay above sand with gravel overlying weak bedrock. No ground water was present in the boring at the time of writing the report. We are assuming that these are the same throughout the excavation, but this should be verified in the field as the excavation advances. For design calculation purposes we have used the following soil parameters as provided in the geotechnical report:

Clayey Sand - Fill

Soil unit weight	125 pcf
Friction angle	37 degrees
Cohesion	75 psf
Bond Strength	0 psi

Sandy Clay

Soil unit weight	130 pcf
Friction angle	30 degrees
Cohesion	100 psf
Bond Strength	16 psi

Bedrock

Soil unit weight	130 pcf
Friction angle	40 degrees
Cohesion	100 psf
Bond Strength	25 psi

Design Parameters and Calculations

Our design conforms to requirements in IBC 2015, ACI 318-14 and the AISC Steel Construction Manual 14th edition and FHWA design recommendations for corrosion degradation of soil reinforcements.

A design life of 75 years has been assumed for corrosion purposes. Corrosion parameters have been chosen based on recommendations in the FHWA publication FHWA-NHI-00-044 and includes a portion of sacrificial steel that is discounted in the design calculations. In addition to the sacrificial steel for corrosion measures the reinforcing bar has at least 3 inches of grout cover. Please see the attached calculation worksheet.

The reinforcing tendons chosen are a solid #8 Grade 75 all-threaded bar and solid #11 Grade 75 all-threaded. Neat cement consists of a Portland Type I&II cement mixed at a water cement ratio of 0.45 to 0.55 with a 28-day strength of 4,000 psi.

For calculation purposes we are using an ultimate grout to soil bond strength of 25 psi.

If subsurface conditions other than those described in the design basis section of this submittal are encountered or if there are changes in the footing location, depth of excavation or surcharge, PDA Engineering Inc. must be notified without delay and be allowed to modify the design to better represent the existing conditions.

We represent that these services were performed in a manner consistent with the level of care and skill normally exercised by other professional consultants under similar

circumstances. No other representation, expressed or implied, and no warranty of guarantee is included or intended. We do not assume responsibility for the accuracy of information provided by others.

We appreciate the opportunity to provide design services for this project. Please contact us if you have any questions or need further clarifications.

Respectfully submitted,

PDA Engineering Inc.



Mike Huot E.I.T.



Per-Ole Danfors, P.E



Attachments:

Shop Drawings
Design Calculations

LOT 44 POWDER MOUNTAIN

8645 EAST COPPER CREST
EDEN, UTAH
DEEP FOUNDATION

DRAWING INDEX

SHEET 1	DRAWING INDEX
SHEET 2	GENERAL NOTES
SHEET 3	SITE PLAN
SHEET 4	CROSS SECTION
SHEET 5	TESTING DETAIL

PLAN REVIEW ACCEPTANCE
FOR COMPLIANCE WITH THE APPLICABLE CONSTRUCTION CODES IDENTIFIED BELOW.

<input checked="" type="checkbox"/> BUILDING	<input checked="" type="checkbox"/> STRUCTURAL
<input checked="" type="checkbox"/> MECHANICAL	<input checked="" type="checkbox"/> PLUMBING
<input checked="" type="checkbox"/> ELECTRICAL	<input checked="" type="checkbox"/> ENERGY
<input type="checkbox"/> ACCESSIBILITY	<input type="checkbox"/> FIRE

PLAN REVIEW ACCEPTANCE OF DOCUMENTS DOES NOT AUTHORIZE CONSTRUCTION TO PROCEED IN VIOLATION OF ANY FEDERAL, STATE, OR LOCAL REGULATIONS.

BY: MEM DATE: 03/04/19
WEST COAST CODE CONSULTANTS, INC.

DESIGN: 801-908-7664
PDA ENGINEERING

CONTRACTOR: 801-908-7664
ADVANCED SHORING+UNDERPINNING

LOT 44 POWDER MOUNTAIN DEEP FOUNDATION EDEN, UTAH				
				NO.



DESIGNED MJH	DATE 2/26/19
DRAWN RDC	SHEET NUMBER 1 of 5
CHECKED MJH	DRAWING INDEX
APPROVED POD	

GENERAL NOTES

1. General
 - 1.1 The scope of work is outlined by these general notes as defined below and includes the installation of new permanent micropiles.
 - 1.2 All utilities must be visually located prior to micropile installation.
 - 1.3 These drawings are the property of Advanced Shoring & Underpinning, Inc. and PDA Engineering, Inc. Drawings or parts of drawings cannot be duplicated without written permission.

2. Micropiles and Hardware.
 - 2.1 Micro pile tendons will be as specified in the micropile schedule or approved equivalent.
 - 2.2 All bars will be straight and undamaged.
 - 2.3 Minimum hole diameter will be as specified in micropile schedule. Holes will be clean and free from obstructions before grouting.
 - 2.4 Hex nuts and couplers will conform to tendon manufacturer's specifications and be capable of transferring the full tensile capacity of the tendon.
 - 2.5 Grout will consist of a neat cement and have a minimum 28-day compressive strength of 4,000 psi with a w/c ratio between 0.45 to 0.55. Mixed grout weight shall be no less than 13 lbs/gal.
 - 2.6 Steel casing type and length will be as specified in micropile schedule.
 - 2.7 Steel plates for micropiles shall be as shown in the plate detail.

3. Micropile Construction Sequence
 - 3.1 Install micropiles in locations and as detailed in these drawings.
 - 3.2 Drill holes in a sequence that that best allows for maneuvering between the piles.
 - 3.3 Micropile Installation Procedures:
 - Open Hole Technique. Drill open holes using compressed air to the required depth. If hole is not open all the way to the required depth re-drill hole. If necessary, use temporary casing to keep hole open and allow for reinforcing to be inserted. Insert reinforcing bar equipped with centralizers and tremmie tube running to within one foot of bottom of bar. Grout hole from bottom of hole to top using the tremmie tube and neat cement grout. Slide steel pipe casing over bar to the required depth. If casing is used, fill hole carefully and adjust level as each casings section is disconnected so that the grout level never falls below the bottom of the casing. Centralizers to be spaced 2 ft. from each end and not more than 8 ft intermeadiate spacing. Centralizers to be not more than 1.5" smaller than drilled hole.
 - 3.4 Cut reinforcing bar and steel sleeve at required cut off elevation. Ensure grout level is at top of hole.
 - 3.5 Keep detailed installation logs for each hole.

4. Special Inspections (by Owner)
 - 4.1 Inspect hole depth, bond zone, hole diameter, installation method and materials as per IBC 2015.
 - 4.2 Sample neat cement daily and perform compression breaks at 7, 14 and 28 days.

5. Pile Tension Testing
 - 5.1 Perform one (1) verification test on a sacrificial pile prior to production pile installation. Location of test pile to be determined by PDA Engineering, and shall represent soil conditions typical for the site of the deep foundation.
 - 5.2 Verification test shall be performed following the verification test schedule provided. The verification test pile may not be used as a production pile.
 - 5.3 The verification test shall be constructed using bars sized as per drawings and/or engineer approved equilivant having a maximum bonded length of 10 feet and a minimum unbonded length of 5 feet to allow for failure of soil to grout bond without exceeding the yield strength of the pile tendon.
 - 5.4 Perform a minumum of 1 proof test per pile type.
 - 5.6 Maximum proof test load shall not exeed 90% for grade 75 and 80% for grade 150 of the yield strength of the bar.

6. Alternate Foundation Design
 - 6.1 Alt. design for foundations P1-P8 24" x 25' deep drilled shaft with (9) #6 vertical rebar spaced evenly with #4 rebar spiral tie at 6" O.C.
 - 6.2 Alt. design for foundations P9 & P10 24" x 30' deep drilled shaft with (9) #6 vertical rebar spaced evenly with #4 rebar spiral tie at 6" O.C.
 - 6.3 Concrete for all drilled shafts to be 4,000 psi and rebar must have a min of 3" clearance.

PLAN REVIEW ACCEPTANCE

FOR COMPLIANCE WITH THE APPLICABLE CONSTRUCTION CODES IDENTIFIED BELOW.

<input checked="" type="checkbox"/> BUILDING	<input checked="" type="checkbox"/> STRUCTURAL
<input checked="" type="checkbox"/> MECHANICAL	<input checked="" type="checkbox"/> PLUMBING
<input checked="" type="checkbox"/> ELECTRICAL	<input checked="" type="checkbox"/> ENERGY
<input type="checkbox"/> ACCESSIBILITY	<input type="checkbox"/> FIRE

PLAN REVIEW ACCEPTANCE OF DOCUMENTS DOES NOT AUTHORIZE CONSTRUCTION TO PROCEED IN VIOLATION OF ANY FEDERAL, STATE, OR LOCAL REGULATIONS.

BY: **MEM** DATE: **03/04/19**

WEST COAST CODE CONSULTANTS, INC.

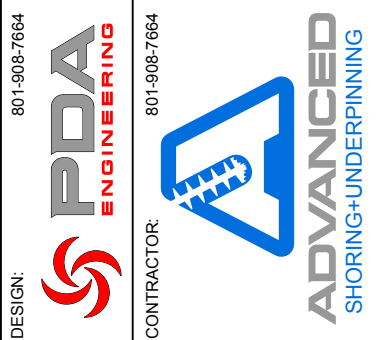

LOT 44 POWDER MOUNTAIN

DEEP FOUNDATION
EDEN, UTAH

NO.	DATE	DRAWN	REVISION

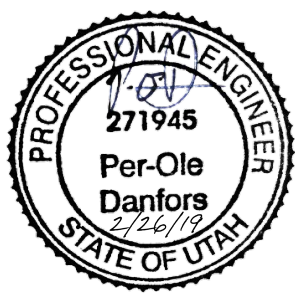

DESIGNED	MJD	DATE	2/26/19
DRAWN	RDC	SHEET NUMBER	
CHECKED	MJD	2 of 5	
APPROVED	POD	GENERAL NOTES	

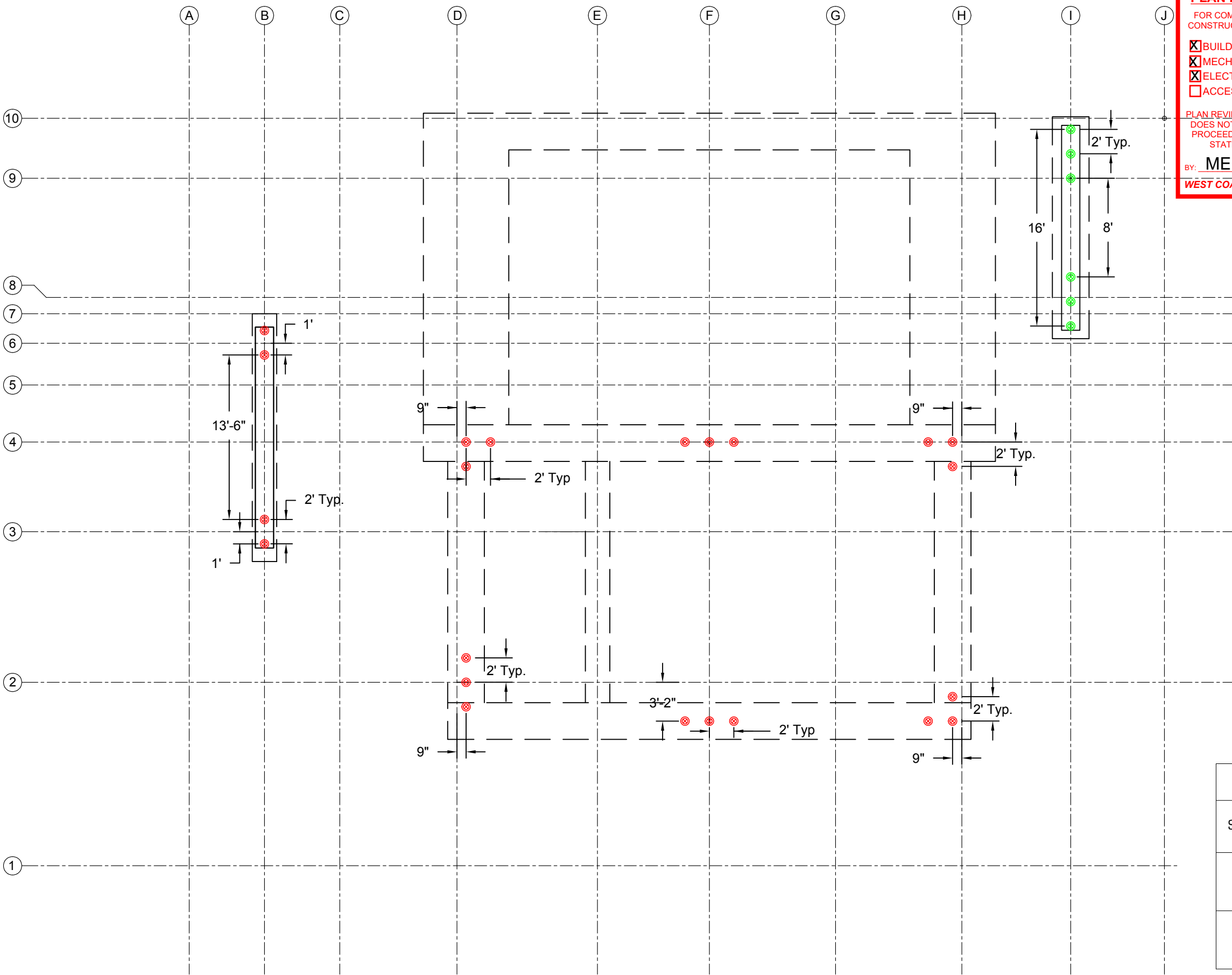

PLAN REVIEW ACCEPTANCE
 FOR COMPLIANCE WITH THE APPLICABLE CONSTRUCTION CODES IDENTIFIED BELOW.

<input checked="" type="checkbox"/> BUILDING	<input checked="" type="checkbox"/> STRUCTURAL
<input checked="" type="checkbox"/> MECHANICAL	<input checked="" type="checkbox"/> PLUMBING
<input checked="" type="checkbox"/> ELECTRICAL	<input checked="" type="checkbox"/> ENERGY
<input type="checkbox"/> ACCESSIBILITY	<input type="checkbox"/> FIRE

PLAN REVIEW ACCEPTANCE OF DOCUMENTS DOES NOT AUTHORIZE CONSTRUCTION TO PROCEED IN VIOLATION OF ANY FEDERAL, STATE, OR LOCAL REGULATIONS.

BY: **MEM** DATE: 03/04/19
WEST COAST CODE CONSULTANTS, INC.

DESIGN: 801-908-7664
PDA ENGINEERING

CONTRACTOR: 801-908-7664
ADVANCED SHORING+UNDERPINNING

LOT 44 POWDER MOUNTAIN
 DEEP FOUNDATION
 EDEN, UTAH

NO.	DATE	DRAWN	REVISION

Legend	
Symbol	Micropile type
	A
	B



SITE PLAN

DESIGNED MJH	DATE 2/26/19
DRAWN RDC	SHEET NUMBER 3 of 5
CHECKED MJH	SITE PLAN
APPROVED POD	

PLAN REVIEW ACCEPTANCE
 FOR COMPLIANCE WITH THE APPLICABLE CONSTRUCTION CODES IDENTIFIED BELOW.

<input checked="" type="checkbox"/> BUILDING	<input checked="" type="checkbox"/> STRUCTURAL
<input checked="" type="checkbox"/> MECHANICAL	<input checked="" type="checkbox"/> PLUMBING
<input checked="" type="checkbox"/> ELECTRICAL	<input checked="" type="checkbox"/> ENERGY
<input type="checkbox"/> ACCESSIBILITY	<input type="checkbox"/> FIRE

PLAN REVIEW ACCEPTANCE OF DOCUMENTS DOES NOT AUTHORIZE CONSTRUCTION TO PROCEED IN VIOLATION OF ANY FEDERAL, STATE, OR LOCAL REGULATIONS.

BY: **MEM** DATE: 03/04/19
WEST COAST CODE CONSULTANTS, INC.

DESIGN: 801-908-7664
PDA ENGINEERING

CONTRACTOR: 801-908-7664
ADVANCED SHORING+UNDERPINNING

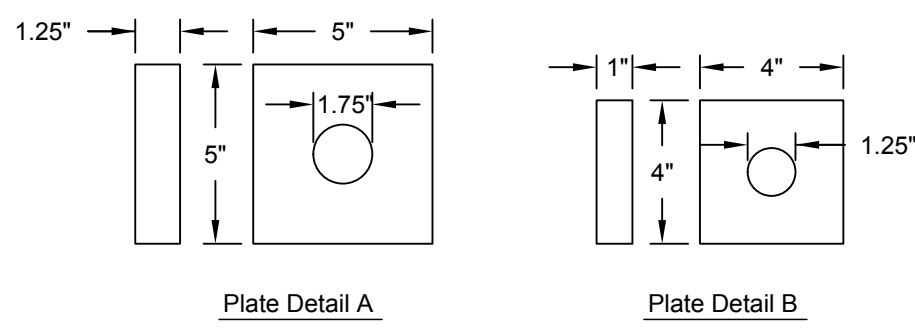
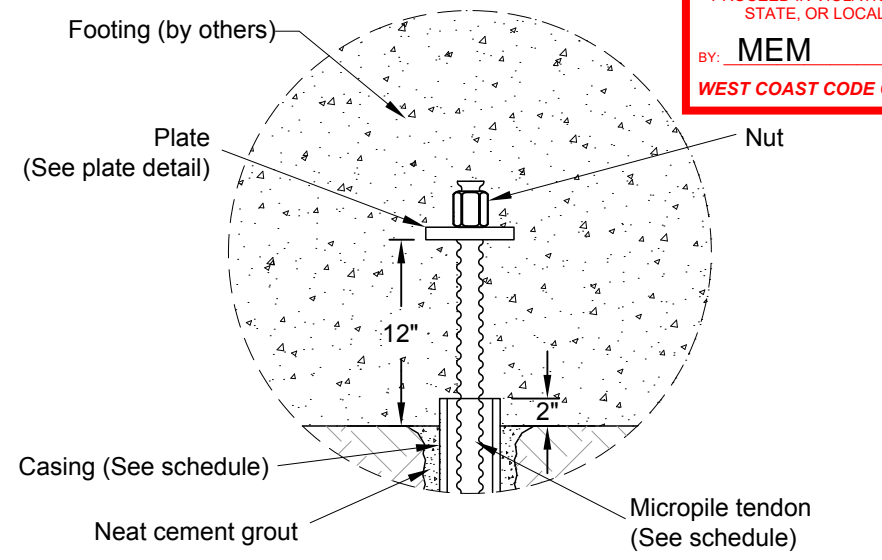
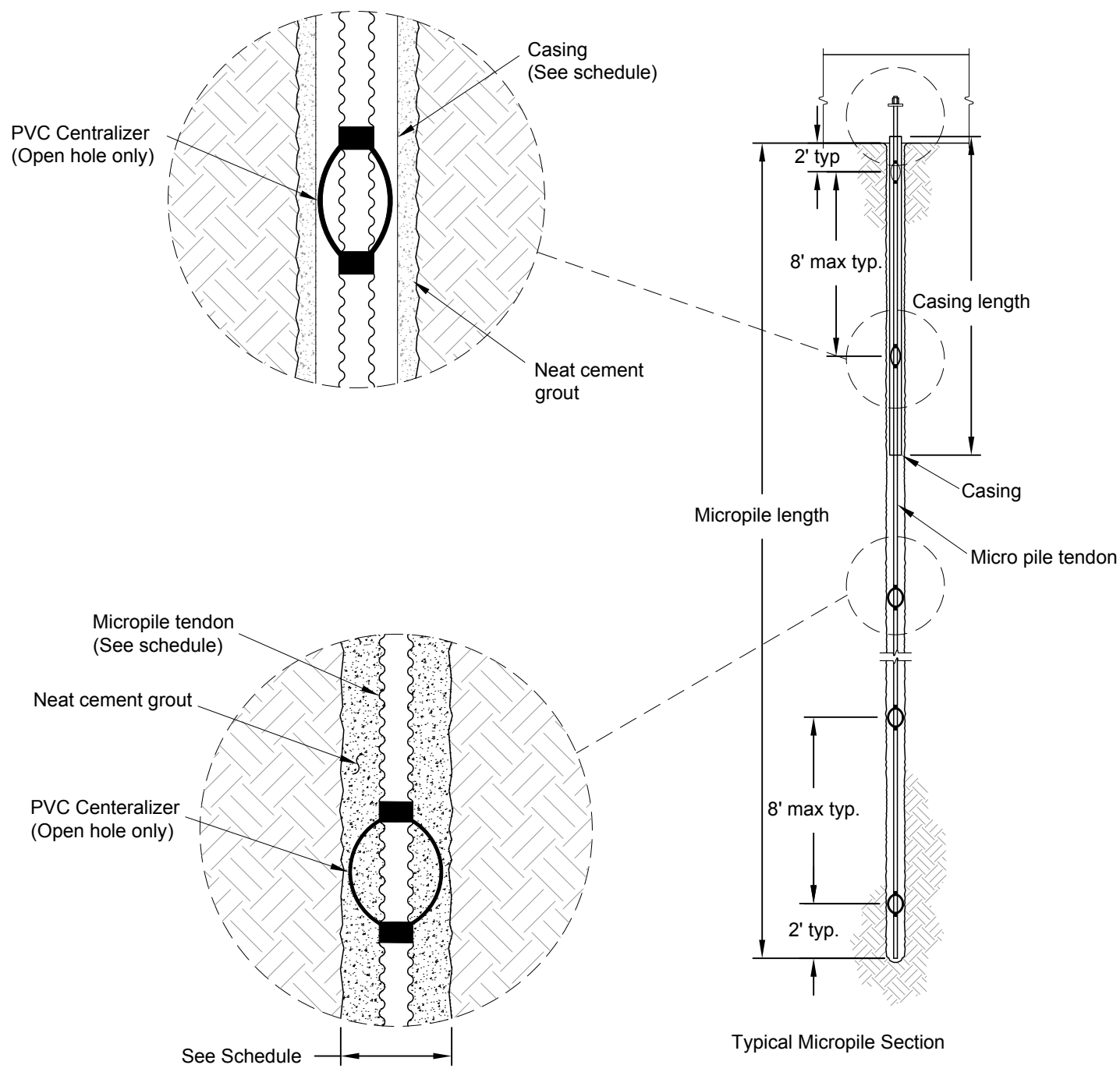

Micro Pile Schedule							
Legend	Micropile type	Tendon size	Hole size	Casing size	Casing length	Micro Pile Length	Plate size
⊗	A	#11 GR75	8"	A36 5" SCH 40	10'	30'	A36 5"x5"x 1.25"
⊗	B	#8 GR75	8"	A36 6" SCH 80	10'	30'	A36 4"x4"x 1"

LOT 44 POWDER MOUNTAIN
 DEEP FOUNDATION
 EDEN, UTAH

NO.	DATE	DRAWN	REVISION

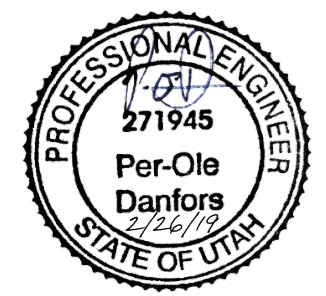

DESIGNED MJH	DATE 2/26/19
DRAWN RDC	SHEET NUMBER 4 of 5
CHECKED MJH	CROSS SECTION
APPROVED POD	

Verification Test Load Schedule	
Test Load Increment	Hold Time (min)
AL (0.05 DTL)	Until Stable
0.25 DTL	Until Stable
0.50 DTL	Until Stable
0.75 DTL	Until Stable
1.00 DTL	Until Stable
1.25 DTL	Until Stable
1.50 DTL (creep test)	See Note Below
1.75 DTL	Until Stable
2.00 DTL	Until Stable
To failure if possible without Exceeding $0.9 * F_y * A$	N/A

DTL = Design Test Load (kips)
 AL = Alignment Load (kips)
 Creep test measurements will be taken at 1, 2, 3, 5, 6, 10, 20, 30, 50, and 60 minutes.

Test Micro Pile Acceptance Criteria:

- The total creep movement is less than 0.04 in. during the 10 minute reading or the total movement is less than 0.08 in. during the 60 minute hold period and the creep rate is linear or decreasing throughout the test hold period.
- The total measured movement exceeds 80% of the theoretical elastic elongation of the unbonded tieback tendon.
- Pullout failure does not occur before max test load. Failure is defined as the inability to further increase the test load while there is continued pullout movement of the test tieback.

Design Parameters				
Soil Type	Unit Weight (psf)	Friction Angle (deg)	Cohesion (psf)	Ultimate Bond Strength (psi)
Bedrock	130	40	100	25

Test Pile Schedule					
Test Pile #	Embedment Depth (ft)	Unbonded Length (UL) (ft)	Tendon Size	Hole Size / Grout body (in)	Design Test Load (kips/ft)
TP1	10'	5'	# 10 or larger	8"	7.5

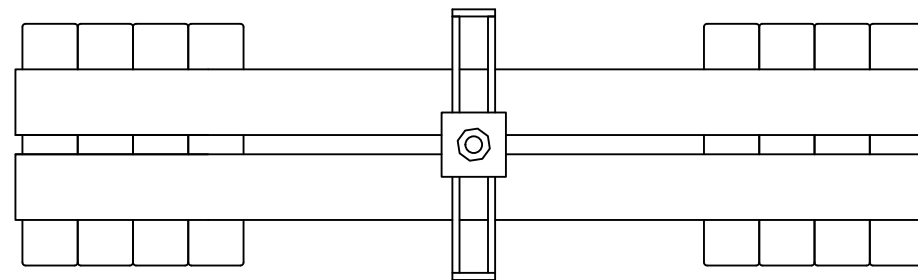
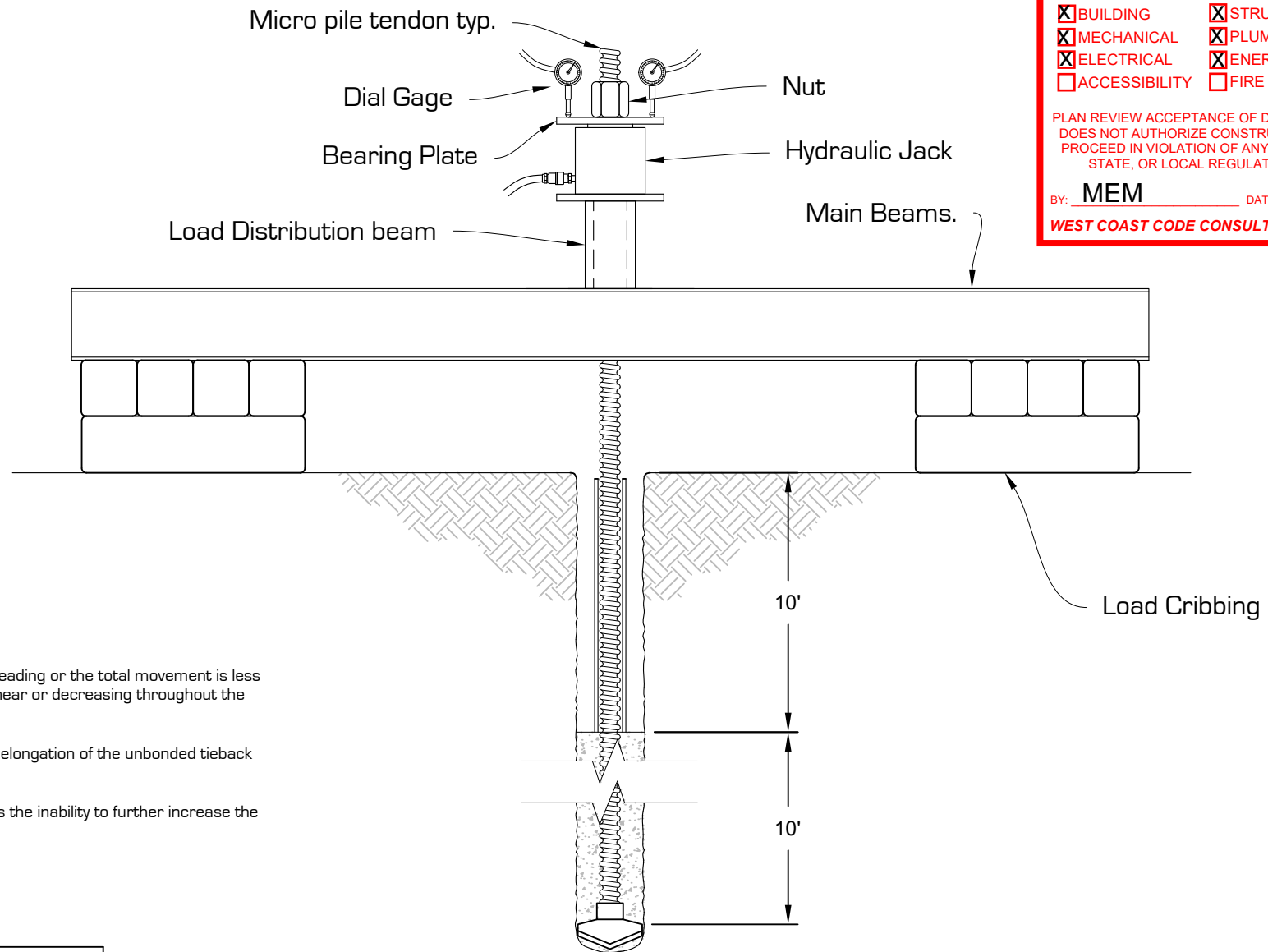

PLAN REVIEW ACCEPTANCE
 FOR COMPLIANCE WITH THE APPLICABLE CONSTRUCTION CODES IDENTIFIED BELOW.

<input checked="" type="checkbox"/> BUILDING	<input checked="" type="checkbox"/> STRUCTURAL
<input checked="" type="checkbox"/> MECHANICAL	<input checked="" type="checkbox"/> PLUMBING
<input checked="" type="checkbox"/> ELECTRICAL	<input checked="" type="checkbox"/> ENERGY
<input type="checkbox"/> ACCESSIBILITY	<input type="checkbox"/> FIRE

PLAN REVIEW ACCEPTANCE OF DOCUMENTS DOES NOT AUTHORIZE CONSTRUCTION TO PROCEED IN VIOLATION OF ANY FEDERAL, STATE, OR LOCAL REGULATIONS.
 BY: **MEM** DATE: 03/04/19
WEST COAST CODE CONSULTANTS, INC.

DESIGN: 801-908-7664
PDA ENGINEERING

CONTRACTOR: 801-908-7664
ADVANCED SHORING+UNDERPINNING

LOT 44 POWDER MOUNTAIN
 DEEP FOUNDATION
 EDEN, UTAH

NO.	DATE	DRAWN	REVISION

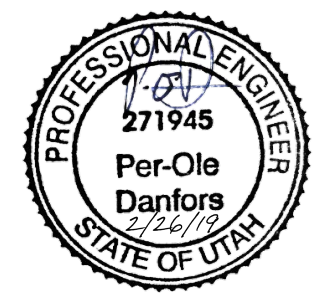

DESIGNED MJH	DATE 2/26/19
DRAWN RDC	SHEET NUMBER 5 of 5
CHECKED MJH	
APPROVED POD	TESTING DETAIL

FOUNDATION PROFILE & SOIL CONDITIONS

For uplift and compression, one no-friction steel casing section and one high pressure grouted section.

Depth from Pile Top-ft	Depth	Width-in	A'-in ²	Per.-in	I'-in ⁴	E -kip ²	W-kip ²
0	0.0	5.583	6.4	17.5	18.5	29000	0.035
Steel (smooth)							
10	10.0	8	63.8	25.1	202.7	3000	0.058
Grouted							
30	30.0						

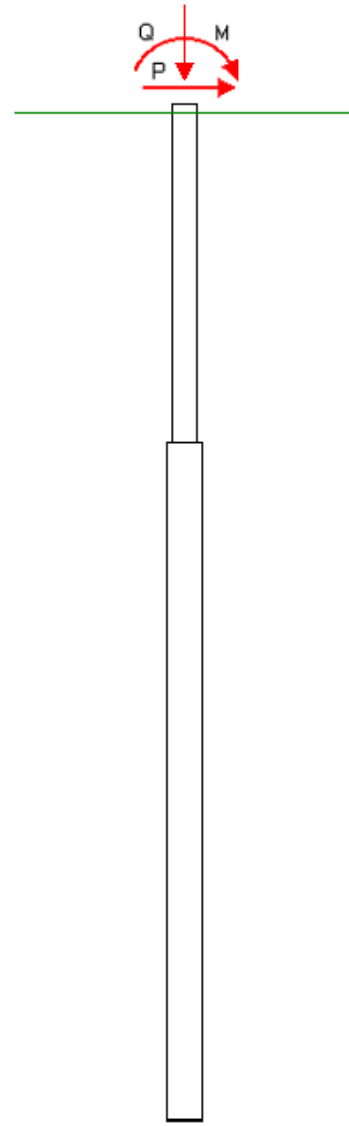

Depth from Pile Top-ft	Depth	γ -lb/ft ³	φ	C-kip/ft ²	k-lb/ft ³	e50 %	N _{spt}
0	0.0	120	30.0	0.10	331.6	0.85	10
Colluvium							
6	6.0	130	40.0	0.10	278.0		50
Bedrock (Tw)							

PLAN REVIEW ACCEPTANCE

FOR COMPLIANCE WITH THE APPLICABLE CONSTRUCTION CODES IDENTIFIED BELOW.

<input checked="" type="checkbox"/> BUILDING	<input checked="" type="checkbox"/> STRUCTURAL
<input checked="" type="checkbox"/> MECHANICAL	<input checked="" type="checkbox"/> PLUMBING
<input checked="" type="checkbox"/> ELECTRICAL	<input checked="" type="checkbox"/> ENERGY
<input type="checkbox"/> ACCESSIBILITY	<input type="checkbox"/> FIRE

PLAN REVIEW ACCEPTANCE OF DOCUMENTS DOES NOT AUTHORIZE CONSTRUCTION TO PROCEED IN VIOLATION OF ANY FEDERAL, STATE, OR LOCAL REGULATIONS.

BY: **MEM** DATE: **03/04/19**

WEST COAST CODE CONSULTANTS, INC.



CivilTech Software

Batter Angle=0 (Pile diameter not to scale) Surface Angle=0

Lot 44 Foundations P1-P8

Figure 1

VERTICAL ANALYSIS

Figure 1

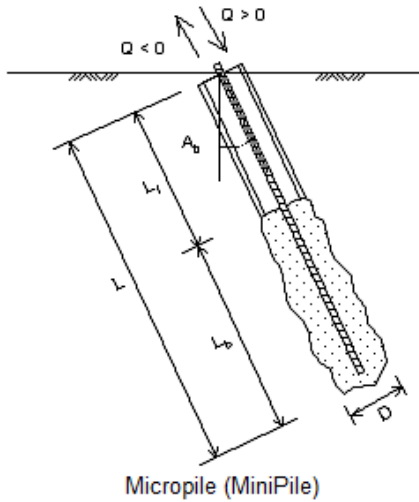

Loads:

Load Factor for Vertical Loads= 1.0
 Load Factor for Lateral Loads= 1.0
 Loads Supported by Pile Cap= 0 %
 Shear Condition: Static

(with Load Factor)

Vertical Load, Q= 150.0 -kp
 Shear Load, P= 8.5 -kp
 Slope Restrain St= 0.00000 -in/in

Profile:

Pile Length, L= 30.0 -ft
 Top Height, H= 0.25 -ft
 Slope Angle, As= 0
 Batter Angle, Ab= 0
 Fixed Head Condition

Soil Data:

Depth -ft	Gamma -lb/f3	Phi	C -kp/f2	K -lb/i3	e50 or Dr %	Nspt
0	120	30.0	0.10	331.6	0.85	10
6	130	40.0	0.10	278.0	85.61	50

Pile Data:

Depth -ft	Width -in	Area -in2	Per. -in	I -in4	E -kp/i2	Weight -kp/f
0.0	5.563	6.4	17.5	18.5	29000	0.035
10.0	8	63.8	25.1	202.7	3000	0.056
30.0						

Vertical Capacity:

Weight above Ground= 0.01 Total Weight= 1.47-kp *Soil Weight is not included
 Side Resistance (Down)= 88.293-kp Side Resistance (Up)= 88.294-kp
 Tip Resistance (Down)= 84.986-kp Tip Resistance (Up)= 0.000-kp
 Total Ultimate Capacity (Down) Qult= 173.279-kp Total Ultimate Capacity (Up)= 89.763-kp
 Total Allowable Capacity (Down) Qallow= 101.355-kp Total Allowable Capacity (Up) Qallow= 45.616-kp
 N/G! Qallow < Q

Settlement Calculation:

At Q= 150.00-kp Settlement= 0.32861-in
 At Xallow= 1.00-in Q= 99999.00000-kp

Note: If the program cannot find a result or the result exceeds the upper limit. The result will be displayed as 99999.



**CivilTech
Software**

**Lot 44
Foundations P1-P8**

Øsummary

ALLPILE 7
VERTICAL ANALYSIS SUMMARY OUTPUT
Copyright by CivilTech Software
www.civiltech.com

TOTAL LOADS:

Vertical Load, Q: 150.0 -kp
Vertical Load with Load Factor, Q: 150.0 -kp
Vertical Load with Load factor and Pile Cap, Q= 150.0 -kp
Load Factor for Vertical Load and Torsion= 1.0
Vertical Loads Supported by Pile Cap: 0 %
Load Factor for Vertical Loads: 1.0

PILE PROFILE:

Pile Length, L= 30.0 -ft
Top Height, H= 0.25 -ft
Slope Angle, As= 0
Batter Angle, Ab= 0.00 Batter Factor, Kbat= 1.00

SINGLE PILE:

Kdown= 1.0 Kup= 1.0 Ka= 1.16

Single Pile Vertical Analysis:

Total Ultimate Capacity (Down)= 173.279-kp Total Ultimate Capacity (Up)= 89.763-kp
Total Allowable Capacity (Down)= 101.355-kp Total Allowable Capacity (Up)= 45.616-kp

Weight above Ground= 0.01 Total Weight= 1.47-kp *Soil Weight is not included
Side Resistance (Down)= 88.293-kp Side Resistance (Up)= 88.294-kp
Tip Resistance (Down)= 84.986-kp Tip Resistance (Up)= 0.000-kp
Negative Friction, Qneg= 0.000-kp, which has been subtracted from Total Ultimate Capacity (Down)
Negative friction does not affect Total Ultimate Capacity (Up)

At Work Load= 150.00-kp, Settlement= 0.32861-in
At Work Load= 150.00-kp, Secant Stiffness Kqx= 456.46-kp/-in
At Allowable Settlement= 1.000000-in, Capacity= 99999.00-kp
Work Load, 150.00-kp, OK with the Capacity at Allowable Settlement= 1.00000-in, Capacity= 99999.00-kp
!!! Work Load, 150.00-kp, Exceeds the Allowable Capacity (Down)= 101.35-kp

FACTOR OF SAFETY:

FSSide FStip FSuplif FSweight
1.5 2.0 2.0 1.0

Note: If the program cannot find a result or the result exceeds the upper limit. The result will be displayed as 99999.

1 1 1 1 1

0detail

ALLPILE 7
 VERTICAL ANALYSIS DETAILED OUTPUT
 Copyright by CivilTech Software
 www.civiltech.com

Pile Profile and Loading:

Piletype: Micropile (MiniPile)
 Pile Length, L= 30.0 -ft
 Top Height, H= 0.25 -ft
 Slope Angle, As= 0
 Batter Angle, Ab= 0.00

Single Pile, Vertical Analysis:

Vertical Load with Load factor, Q= 150.0 -kp
 Vertical Load with Load factor and Pile Cap, Q= 150.0 -kp
 Load Factor for Vertical Loads= 1.0
 Vertical Loads Supported by Pile Cap: 0 %
 Kdown= 1.0 Kup= 1.0 Ka= 1.16

Bearing stratum from pile tip extending to 10 Diameter of pile, which is=6.7-ft Starting from Pile Tip= 29.8-ft
 From Ztip=29.8 to 36.4-ft Average Properties: Es= 799.92-kp/f2 C=0.10-kp/f2 Friction=40.00 Cp=0.03 Ksand=1.00
 Limits of Max. tip resistance, q_lim= N/A
 Batter Angle, Ab= 0.00 Batter Factor, Kbat= 1.00
 Qtip_dw=85.0-kp based on qult=243.3-kp/f2 and Base Area=0.3-ft2
 Qtip_up=0.0-kp and Base Area=0.0-ft2

TIP RESISTANCE (Down) CALCULATION:

Tip Depth= 29.8-ft Critical Depth Ratio Z/D= 20 Critical Depth= 13.3-ft
 Equivalent Width of Tip= 0.67-ft, Tip Area= 0.35-ft2 Tip Diameter= 0.67-ft
 Bearing stratum from pile tip extending to 10 Diameter of pile. Bearing stratum= 6.67-ft
 Btip: width at pile tip= 0.67-ft (For group pile, it is equivalent width).
 Phi & C are average value in bearing stratum.
 Batter Angle= 0.00, Batter Factor for Tip and Side= 1.00

Ztip -ft	Z/D	Z_lim -ft	q_lim -kp/f2	Width -ft	Area' -ft2	Phi - o	C -kp/f2	Nq	Nc	Sv -kp/f2	qult -kp/f2	Qtip_dw -kp
29.8	20.0	13.3	N/A	0.67	0.35	40.0	0.10	145.0	9.0	1.7	243.3	85.0

Ztip - Depth of pile tip from ground surface (Zs)
 D - Pile average diameter (below ground) for calculation of critical depth. D=0.67-ft
 Z/D - Critical depth (for tip resistances) as ratio of depth/diameter. Vertical stress will be constant below critical depth
 Z_lim - Critical depth, calculated from Z/D (for tip resistances)
 q_lim - Limit of Maximum tip resistance
 Btip: width or diameter at pile tip
 Bearing stratum: A stratum from pile tip extending to some depth. Average soil properties in the stratum are used for bearing calculation

SIDE RESISTANCE (Uplift & Down) CALCULATION:

D -ft	Z/D	Z_lim -ft	Sf_lim -kp/f2	K_dw	K_up	dz -ft
0.67	20.0	13.33	N/A	1.0	1.0	0.060

D - Pile average diameter for calculation of critical depth
 Z/D - Critical depth (for side resistances) as ratio of depth/diameter. Vertical stress will be constant below critical depth
 Z_lim - Critical depth calculated from Z/D (for side resistances)
 Sf_lim - Limit of Maximum side resistance

SIDE RESISTANCE (Up & Down) CALCULATION vs DEPTH:

Calculation is based on segment dz= 0.06

Zs	Prem	Sv	Phi	Kf(<2)	Delta	f_dw	Ødetail f_up	C	Ka	Kc(<2)	Ca_dw	Ca_up	Sf_dw
Sf_up	Weight	Qneg	Q_dw	Q_up	Torsion	-kp/f2	-kp/f2	-kp/f2		Ca	-kp/f2	-kp/f2	-kp/f2
-ft	-ft	-kp/f2	- o	Delta	- o								
-kp/f2	-kp	-kp	-kp	-kp	-kp-f								
29.75	2.09	1.67	40.0	0.00	0.0	0.00	0.00	0.10	1.16	2000.00	2.00	2.00	0.00
0.00	0.00	0.00	85.0	0.0	0.0								
29.69	2.09	1.67	40.0	0.00	0.0	0.00	0.00	0.10	1.16	2000.00	2.00	2.00	2.00
2.00	0.00	0.00	85.2	0.3	0.1								
29.63	2.09	1.67	40.0	0.00	0.0	0.00	0.00	0.10	1.16	2000.00	2.00	2.00	2.00
2.00	0.01	0.00	85.5	0.5	0.2								
29.57	2.09	1.67	40.0	0.00	0.0	0.00	0.00	0.10	1.16	2000.00	2.00	2.00	2.00
2.00	0.01	0.00	85.7	0.8	0.2								
29.51	2.09	1.67	40.0	0.00	0.0	0.00	0.00	0.10	1.16	2000.00	2.00	2.00	2.00
2.00	0.01	0.00	86.0	1.0	0.3								
29.45	2.09	1.67	40.0	0.00	0.0	0.00	0.00	0.10	1.16	2000.00	2.00	2.00	2.00
2.00	0.02	0.00	86.2	1.3	0.4								
29.39	2.09	1.67	40.0	0.00	0.0	0.00	0.00	0.10	1.16	2000.00	2.00	2.00	2.00
2.00	0.02	0.00	86.5	1.5	0.5								
29.33	2.09	1.67	40.0	0.00	0.0	0.00	0.00	0.10	1.16	2000.00	2.00	2.00	2.00
2.00	0.02	0.00	86.7	1.8	0.6								
29.27	2.09	1.67	40.0	0.00	0.0	0.00	0.00	0.10	1.16	2000.00	2.00	2.00	2.00
2.00	0.03	0.00	87.0	2.0	0.7								
29.21	2.09	1.67	40.0	0.00	0.0	0.00	0.00	0.10	1.16	2000.00	2.00	2.00	2.00
2.00	0.03	0.00	87.2	2.3	0.7								
29.15	2.09	1.67	40.0	0.00	0.0	0.00	0.00	0.10	1.16	2000.00	2.00	2.00	2.00
2.00	0.03	0.00	87.5	2.5	0.8								
29.09	2.09	1.67	40.0	0.00	0.0	0.00	0.00	0.10	1.16	2000.00	2.00	2.00	2.00
2.00	0.04	0.00	87.7	2.8	0.9								
29.03	2.09	1.67	40.0	0.00	0.0	0.00	0.00	0.10	1.16	2000.00	2.00	2.00	2.00
2.00	0.04	0.00	88.0	3.0	1.0								
28.97	2.09	1.67	40.0	0.00	0.0	0.00	0.00	0.10	1.16	2000.00	2.00	2.00	2.00
2.00	0.04	0.00	88.2	3.3	1.1								
28.92	2.09	1.67	40.0	0.00	0.0	0.00	0.00	0.10	1.16	2000.00	2.00	2.00	2.00
2.00	0.05	0.00	88.5	3.5	1.2								
28.86	2.09	1.67	40.0	0.00	0.0	0.00	0.00	0.10	1.16	2000.00	2.00	2.00	2.00
2.00	0.05	0.00	88.7	3.8	1.2								
28.80	2.09	1.67	40.0	0.00	0.0	0.00	0.00	0.10	1.16	2000.00	2.00	2.00	2.00
2.00	0.05	0.00	89.0	4.0	1.3								
28.74	2.09	1.67	40.0	0.00	0.0	0.00	0.00	0.10	1.16	2000.00	2.00	2.00	2.00
2.00	0.06	0.00	89.2	4.3	1.4								
28.68	2.09	1.67	40.0	0.00	0.0	0.00	0.00	0.10	1.16	2000.00	2.00	2.00	2.00
2.00	0.06	0.00	89.5	4.5	1.5								
28.62	2.09	1.67	40.0	0.00	0.0	0.00	0.00	0.10	1.16	2000.00	2.00	2.00	2.00
2.00	0.06	0.00	89.7	4.8	1.6								
28.56	2.09	1.67	40.0	0.00	0.0	0.00	0.00	0.10	1.16	2000.00	2.00	2.00	2.00
2.00	0.07	0.00	90.0	5.1	1.7								
28.50	2.09	1.67	40.0	0.00	0.0	0.00	0.00	0.10	1.16	2000.00	2.00	2.00	2.00
2.00	0.07	0.00	90.2	5.3	1.7								
28.44	2.09	1.67	40.0	0.00	0.0	0.00	0.00	0.10	1.16	2000.00	2.00	2.00	2.00
2.00	0.07	0.00	90.5	5.6	1.8								
28.38	2.09	1.67	40.0	0.00	0.0	0.00	0.00	0.10	1.16	2000.00	2.00	2.00	2.00
2.00	0.08	0.00	90.7	5.8	1.9								
28.32	2.09	1.67	40.0	0.00	0.0	0.00	0.00	0.10	1.16	2000.00	2.00	2.00	2.00
2.00	0.08	0.00	91.0	6.1	2.0								
28.26	2.09	1.67	40.0	0.00	0.0	0.00	0.00	0.10	1.16	2000.00	2.00	2.00	2.00
2.00	0.08	0.00	91.2	6.3	2.1								
28.20	2.09	1.67	40.0	0.00	0.0	0.00	0.00	0.10	1.16	2000.00	2.00	2.00	2.00
2.00	0.09	0.00	91.5	6.6	2.2								
28.14	2.09	1.67	40.0	0.00	0.0	0.00	0.00	0.10	1.16	2000.00	2.00	2.00	2.00
2.00	0.09	0.00	91.7	6.8	2.2								
28.08	2.09	1.67	40.0	0.00	0.0	0.00	0.00	0.10	1.16	2000.00	2.00	2.00	2.00
2.00	0.09	0.00	92.0	7.1	2.3								
28.02	2.09	1.67	40.0	0.00	0.0	0.00	0.00	0.10	1.16	2000.00	2.00	2.00	2.00
2.00	0.10	0.00	92.2	7.3	2.4								
27.96	2.09	1.67	40.0	0.00	0.0	0.00	0.00	0.10	1.16	2000.00	2.00	2.00	2.00

Ødetail

2.00	0.10	0.00	92.5	7.6	2.5								
27.90	2.09	1.67	40.0	0.00	0.0	0.00	0.00	0.10	1.16	2000.00	2.00	2.00	2.00
2.00	0.10	0.00	92.7	7.8	2.6								
27.84	2.09	1.67	40.0	0.00	0.0	0.00	0.00	0.10	1.16	2000.00	2.00	2.00	2.00
2.00	0.11	0.00	93.0	8.1	2.7								
27.78	2.09	1.67	40.0	0.00	0.0	0.00	0.00	0.10	1.16	2000.00	2.00	2.00	2.00
2.00	0.11	0.00	93.2	8.3	2.7								
27.72	2.09	1.67	40.0	0.00	0.0	0.00	0.00	0.10	1.16	2000.00	2.00	2.00	2.00
2.00	0.11	0.00	93.5	8.6	2.8								
27.66	2.09	1.67	40.0	0.00	0.0	0.00	0.00	0.10	1.16	2000.00	2.00	2.00	2.00
2.00	0.12	0.00	93.7	8.8	2.9								
27.60	2.09	1.67	40.0	0.00	0.0	0.00	0.00	0.10	1.16	2000.00	2.00	2.00	2.00
2.00	0.12	0.00	94.0	9.1	3.0								
27.54	2.09	1.67	40.0	0.00	0.0	0.00	0.00	0.10	1.16	2000.00	2.00	2.00	2.00
2.00	0.12	0.00	94.2	9.4	3.1								
27.48	2.09	1.67	40.0	0.00	0.0	0.00	0.00	0.10	1.16	2000.00	2.00	2.00	2.00
2.00	0.13	0.00	94.5	9.6	3.2								
27.42	2.09	1.67	40.0	0.00	0.0	0.00	0.00	0.10	1.16	2000.00	2.00	2.00	2.00
2.00	0.13	0.00	94.7	9.9	3.2								
27.37	2.09	1.67	40.0	0.00	0.0	0.00	0.00	0.10	1.16	2000.00	2.00	2.00	2.00
2.00	0.13	0.00	95.0	10.1	3.3								
27.31	2.09	1.67	40.0	0.00	0.0	0.00	0.00	0.10	1.16	2000.00	2.00	2.00	2.00
2.00	0.14	0.00	95.2	10.4	3.4								
27.25	2.09	1.67	40.0	0.00	0.0	0.00	0.00	0.10	1.16	2000.00	2.00	2.00	2.00
2.00	0.14	0.00	95.5	10.6	3.5								
27.19	2.09	1.67	40.0	0.00	0.0	0.00	0.00	0.10	1.16	2000.00	2.00	2.00	2.00
2.00	0.14	0.00	95.7	10.9	3.6								
27.13	2.09	1.67	40.0	0.00	0.0	0.00	0.00	0.10	1.16	2000.00	2.00	2.00	2.00
2.00	0.15	0.00	96.0	11.1	3.7								
27.07	2.09	1.67	40.0	0.00	0.0	0.00	0.00	0.10	1.16	2000.00	2.00	2.00	2.00
2.00	0.15	0.00	96.2	11.4	3.7								
27.01	2.09	1.67	40.0	0.00	0.0	0.00	0.00	0.10	1.16	2000.00	2.00	2.00	2.00
2.00	0.15	0.00	96.5	11.6	3.8								
26.95	2.09	1.67	40.0	0.00	0.0	0.00	0.00	0.10	1.16	2000.00	2.00	2.00	2.00
2.00	0.16	0.00	96.7	11.9	3.9								
26.89	2.09	1.67	40.0	0.00	0.0	0.00	0.00	0.10	1.16	2000.00	2.00	2.00	2.00
2.00	0.16	0.00	97.0	12.1	4.0								
26.83	2.09	1.67	40.0	0.00	0.0	0.00	0.00	0.10	1.16	2000.00	2.00	2.00	2.00
2.00	0.16	0.00	97.2	12.4	4.1								
26.77	2.09	1.67	40.0	0.00	0.0	0.00	0.00	0.10	1.16	2000.00	2.00	2.00	2.00
2.00	0.17	0.00	97.5	12.6	4.2								
26.71	2.09	1.67	40.0	0.00	0.0	0.00	0.00	0.10	1.16	2000.00	2.00	2.00	2.00
2.00	0.17	0.00	97.7	12.9	4.2								
26.65	2.09	1.67	40.0	0.00	0.0	0.00	0.00	0.10	1.16	2000.00	2.00	2.00	2.00
2.00	0.17	0.00	98.0	13.1	4.3								
26.59	2.09	1.67	40.0	0.00	0.0	0.00	0.00	0.10	1.16	2000.00	2.00	2.00	2.00
2.00	0.18	0.00	98.2	13.4	4.4								
26.53	2.09	1.67	40.0	0.00	0.0	0.00	0.00	0.10	1.16	2000.00	2.00	2.00	2.00
2.00	0.18	0.00	98.5	13.6	4.5								
26.47	2.09	1.67	40.0	0.00	0.0	0.00	0.00	0.10	1.16	2000.00	2.00	2.00	2.00
2.00	0.18	0.00	98.7	13.9	4.6								
26.41	2.09	1.67	40.0	0.00	0.0	0.00	0.00	0.10	1.16	2000.00	2.00	2.00	2.00
2.00	0.19	0.00	99.0	14.2	4.6								
26.35	2.09	1.67	40.0	0.00	0.0	0.00	0.00	0.10	1.16	2000.00	2.00	2.00	2.00
2.00	0.19	0.00	99.2	14.4	4.7								
26.29	2.09	1.67	40.0	0.00	0.0	0.00	0.00	0.10	1.16	2000.00	2.00	2.00	2.00
2.00	0.19	0.00	99.5	14.7	4.8								
26.23	2.09	1.67	40.0	0.00	0.0	0.00	0.00	0.10	1.16	2000.00	2.00	2.00	2.00
2.00	0.20	0.00	99.7	14.9	4.9								
26.17	2.09	1.67	40.0	0.00	0.0	0.00	0.00	0.10	1.16	2000.00	2.00	2.00	2.00
2.00	0.20	0.00	100.0	15.2	5.0								
26.11	2.09	1.67	40.0	0.00	0.0	0.00	0.00	0.10	1.16	2000.00	2.00	2.00	2.00
2.00	0.20	0.00	100.2	15.4	5.1								
26.05	2.09	1.67	40.0	0.00	0.0	0.00	0.00	0.10	1.16	2000.00	2.00	2.00	2.00
2.00	0.21	0.00	100.4	15.7	5.1								
25.99	2.09	1.67	40.0	0.00	0.0	0.00	0.00	0.10	1.16	2000.00	2.00	2.00	2.00
2.00	0.21	0.00	100.7	15.9	5.2								

													0detail
25.93	2.09	1.67	40.0	0.00	0.0	0.00	0.00	0.10	1.16	2000.00	2.00	2.00	2.00
2.00	0.21	0.00	100.9	16.2	5.3								
25.87	2.09	1.67	40.0	0.00	0.0	0.00	0.00	0.10	1.16	2000.00	2.00	2.00	2.00
2.00	0.22	0.00	101.2	16.4	5.4								
25.82	2.09	1.67	40.0	0.00	0.0	0.00	0.00	0.10	1.16	2000.00	2.00	2.00	2.00
2.00	0.22	0.00	101.4	16.7	5.5								
25.76	2.09	1.67	40.0	0.00	0.0	0.00	0.00	0.10	1.16	2000.00	2.00	2.00	2.00
2.00	0.22	0.00	101.7	16.9	5.6								
25.70	2.09	1.67	40.0	0.00	0.0	0.00	0.00	0.10	1.16	2000.00	2.00	2.00	2.00
2.00	0.23	0.00	101.9	17.2	5.6								
25.64	2.09	1.67	40.0	0.00	0.0	0.00	0.00	0.10	1.16	2000.00	2.00	2.00	2.00
2.00	0.23	0.00	102.2	17.4	5.7								
25.58	2.09	1.67	40.0	0.00	0.0	0.00	0.00	0.10	1.16	2000.00	2.00	2.00	2.00
2.00	0.23	0.00	102.4	17.7	5.8								
25.52	2.09	1.67	40.0	0.00	0.0	0.00	0.00	0.10	1.16	2000.00	2.00	2.00	2.00
2.00	0.24	0.00	102.7	17.9	5.9								
25.46	2.09	1.67	40.0	0.00	0.0	0.00	0.00	0.10	1.16	2000.00	2.00	2.00	2.00
2.00	0.24	0.00	102.9	18.2	6.0								
25.40	2.09	1.67	40.0	0.00	0.0	0.00	0.00	0.10	1.16	2000.00	2.00	2.00	2.00
2.00	0.24	0.00	103.2	18.5	6.1								
25.34	2.09	1.67	40.0	0.00	0.0	0.00	0.00	0.10	1.16	2000.00	2.00	2.00	2.00
2.00	0.25	0.00	103.4	18.7	6.1								
25.28	2.09	1.67	40.0	0.00	0.0	0.00	0.00	0.10	1.16	2000.00	2.00	2.00	2.00
2.00	0.25	0.00	103.7	19.0	6.2								
25.22	2.09	1.67	40.0	0.00	0.0	0.00	0.00	0.10	1.16	2000.00	2.00	2.00	2.00
2.00	0.25	0.00	103.9	19.2	6.3								
25.16	2.09	1.67	40.0	0.00	0.0	0.00	0.00	0.10	1.16	2000.00	2.00	2.00	2.00
2.00	0.26	0.00	104.2	19.5	6.4								
25.10	2.09	1.67	40.0	0.00	0.0	0.00	0.00	0.10	1.16	2000.00	2.00	2.00	2.00
2.00	0.26	0.00	104.4	19.7	6.5								
25.04	2.09	1.67	40.0	0.00	0.0	0.00	0.00	0.10	1.16	2000.00	2.00	2.00	2.00
2.00	0.26	0.00	104.7	20.0	6.6								
24.98	2.09	1.67	40.0	0.00	0.0	0.00	0.00	0.10	1.16	2000.00	2.00	2.00	2.00
2.00	0.27	0.00	104.9	20.2	6.6								
24.92	2.09	1.67	40.0	0.00	0.0	0.00	0.00	0.10	1.16	2000.00	2.00	2.00	2.00
2.00	0.27	0.00	105.2	20.5	6.7								
24.86	2.09	1.67	40.0	0.00	0.0	0.00	0.00	0.10	1.16	2000.00	2.00	2.00	2.00
2.00	0.27	0.00	105.4	20.7	6.8								
24.80	2.09	1.67	40.0	0.00	0.0	0.00	0.00	0.10	1.16	2000.00	2.00	2.00	2.00
2.00	0.28	0.00	105.7	21.0	6.9								
24.74	2.09	1.67	40.0	0.00	0.0	0.00	0.00	0.10	1.16	2000.00	2.00	2.00	2.00
2.00	0.28	0.00	105.9	21.2	7.0								
24.68	2.09	1.67	40.0	0.00	0.0	0.00	0.00	0.10	1.16	2000.00	2.00	2.00	2.00
2.00	0.28	0.00	106.2	21.5	7.1								
24.62	2.09	1.67	40.0	0.00	0.0	0.00	0.00	0.10	1.16	2000.00	2.00	2.00	2.00
2.00	0.29	0.00	106.4	21.7	7.1								
24.56	2.09	1.67	40.0	0.00	0.0	0.00	0.00	0.10	1.16	2000.00	2.00	2.00	2.00
2.00	0.29	0.00	106.7	22.0	7.2								
24.50	2.09	1.67	40.0	0.00	0.0	0.00	0.00	0.10	1.16	2000.00	2.00	2.00	2.00
2.00	0.29	0.00	106.9	22.2	7.3								
24.44	2.09	1.67	40.0	0.00	0.0	0.00	0.00	0.10	1.16	2000.00	2.00	2.00	2.00
2.00	0.30	0.00	107.2	22.5	7.4								
24.38	2.09	1.67	40.0	0.00	0.0	0.00	0.00	0.10	1.16	2000.00	2.00	2.00	2.00
2.00	0.30	0.00	107.4	22.7	7.5								
24.32	2.09	1.67	40.0	0.00	0.0	0.00	0.00	0.10	1.16	2000.00	2.00	2.00	2.00
2.00	0.30	0.00	107.7	23.0	7.6								
24.27	2.09	1.67	40.0	0.00	0.0	0.00	0.00	0.10	1.16	2000.00	2.00	2.00	2.00
2.00	0.31	0.00	107.9	23.3	7.6								
24.21	2.09	1.67	40.0	0.00	0.0	0.00	0.00	0.10	1.16	2000.00	2.00	2.00	2.00
2.00	0.31	0.00	108.2	23.5	7.7								
24.15	2.09	1.67	40.0	0.00	0.0	0.00	0.00	0.10	1.16	2000.00	2.00	2.00	2.00
2.00	0.31	0.00	108.4	23.8	7.8								
24.09	2.09	1.67	40.0	0.00	0.0	0.00	0.00	0.10	1.16	2000.00	2.00	2.00	2.00
2.00	0.32	0.00	108.7	24.0	7.9								
24.03	2.09	1.67	40.0	0.00	0.0	0.00	0.00	0.10	1.16	2000.00	2.00	2.00	2.00
2.00	0.32	0.00	108.9	24.3	8.0								
23.97	2.09	1.67	40.0	0.00	0.0	0.00	0.00	0.10	1.16	2000.00	2.00	2.00	2.00

Ødetail												
2.00	0.32	0.00	109.2	24.5	8.1							
23.91	2.09	1.67	40.0	0.00	0.0	0.00	0.00	0.10	1.16	2000.00	2.00	2.00
2.00	0.33	0.00	109.4	24.8	8.1							
23.85	2.09	1.67	40.0	0.00	0.0	0.00	0.00	0.10	1.16	2000.00	2.00	2.00
2.00	0.33	0.00	109.7	25.0	8.2							
23.79	2.09	1.67	40.0	0.00	0.0	0.00	0.00	0.10	1.16	2000.00	2.00	2.00
2.00	0.33	0.00	109.9	25.3	8.3							
23.73	2.09	1.67	40.0	0.00	0.0	0.00	0.00	0.10	1.16	2000.00	2.00	2.00
2.00	0.34	0.00	110.2	25.5	8.4							
23.67	2.09	1.67	40.0	0.00	0.0	0.00	0.00	0.10	1.16	2000.00	2.00	2.00
2.00	0.34	0.00	110.4	25.8	8.5							
23.61	2.09	1.67	40.0	0.00	0.0	0.00	0.00	0.10	1.16	2000.00	2.00	2.00
2.00	0.34	0.00	110.7	26.0	8.6							
23.55	2.09	1.67	40.0	0.00	0.0	0.00	0.00	0.10	1.16	2000.00	2.00	2.00
2.00	0.35	0.00	110.9	26.3	8.6							
23.49	2.09	1.67	40.0	0.00	0.0	0.00	0.00	0.10	1.16	2000.00	2.00	2.00
2.00	0.35	0.00	111.2	26.5	8.7							
23.43	2.09	1.67	40.0	0.00	0.0	0.00	0.00	0.10	1.16	2000.00	2.00	2.00
2.00	0.35	0.00	111.4	26.8	8.8							
23.37	2.09	1.67	40.0	0.00	0.0	0.00	0.00	0.10	1.16	2000.00	2.00	2.00
2.00	0.36	0.00	111.7	27.0	8.9							
23.31	2.09	1.67	40.0	0.00	0.0	0.00	0.00	0.10	1.16	2000.00	2.00	2.00
2.00	0.36	0.00	111.9	27.3	9.0							
23.25	2.09	1.67	40.0	0.00	0.0	0.00	0.00	0.10	1.16	2000.00	2.00	2.00
2.00	0.36	0.00	112.2	27.5	9.0							
23.19	2.09	1.67	40.0	0.00	0.0	0.00	0.00	0.10	1.16	2000.00	2.00	2.00
2.00	0.37	0.00	112.4	27.8	9.1							
23.13	2.09	1.67	40.0	0.00	0.0	0.00	0.00	0.10	1.16	2000.00	2.00	2.00
2.00	0.37	0.00	112.7	28.1	9.2							
23.07	2.09	1.67	40.0	0.00	0.0	0.00	0.00	0.10	1.16	2000.00	2.00	2.00
2.00	0.37	0.00	112.9	28.3	9.3							
23.01	2.09	1.67	40.0	0.00	0.0	0.00	0.00	0.10	1.16	2000.00	2.00	2.00
2.00	0.38	0.00	113.2	28.6	9.4							
22.95	2.09	1.67	40.0	0.00	0.0	0.00	0.00	0.10	1.16	2000.00	2.00	2.00
2.00	0.38	0.00	113.4	28.8	9.5							
22.89	2.09	1.67	40.0	0.00	0.0	0.00	0.00	0.10	1.16	2000.00	2.00	2.00
2.00	0.38	0.00	113.7	29.1	9.5							
22.83	2.09	1.67	40.0	0.00	0.0	0.00	0.00	0.10	1.16	2000.00	2.00	2.00
2.00	0.39	0.00	113.9	29.3	9.6							
22.77	2.09	1.67	40.0	0.00	0.0	0.00	0.00	0.10	1.16	2000.00	2.00	2.00
2.00	0.39	0.00	114.2	29.6	9.7							
22.71	2.09	1.67	40.0	0.00	0.0	0.00	0.00	0.10	1.16	2000.00	2.00	2.00
2.00	0.39	0.00	114.4	29.8	9.8							
22.66	2.09	1.67	40.0	0.00	0.0	0.00	0.00	0.10	1.16	2000.00	2.00	2.00
2.00	0.40	0.00	114.7	30.1	9.9							
22.60	2.09	1.67	40.0	0.00	0.0	0.00	0.00	0.10	1.16	2000.00	2.00	2.00
2.00	0.40	0.00	114.9	30.3	10.0							
22.54	2.09	1.67	40.0	0.00	0.0	0.00	0.00	0.10	1.16	2000.00	2.00	2.00
2.00	0.40	0.00	115.2	30.6	10.0							
22.48	2.09	1.67	40.0	0.00	0.0	0.00	0.00	0.10	1.16	2000.00	2.00	2.00
2.00	0.41	0.00	115.4	30.8	10.1							
22.42	2.09	1.67	40.0	0.00	0.0	0.00	0.00	0.10	1.16	2000.00	2.00	2.00
2.00	0.41	0.00	115.7	31.1	10.2							
22.36	2.09	1.67	40.0	0.00	0.0	0.00	0.00	0.10	1.16	2000.00	2.00	2.00
2.00	0.41	0.00	115.9	31.3	10.3							
22.30	2.09	1.67	40.0	0.00	0.0	0.00	0.00	0.10	1.16	2000.00	2.00	2.00
2.00	0.42	0.00	116.2	31.6	10.4							
22.24	2.09	1.67	40.0	0.00	0.0	0.00	0.00	0.10	1.16	2000.00	2.00	2.00
2.00	0.42	0.00	116.4	31.8	10.5							
22.18	2.09	1.67	40.0	0.00	0.0	0.00	0.00	0.10	1.16	2000.00	2.00	2.00
2.00	0.42	0.00	116.7	32.1	10.5							
22.12	2.09	1.67	40.0	0.00	0.0	0.00	0.00	0.10	1.16	2000.00	2.00	2.00
2.00	0.43	0.00	116.9	32.4	10.6							
22.06	2.09	1.67	40.0	0.00	0.0	0.00	0.00	0.10	1.16	2000.00	2.00	2.00
2.00	0.43	0.00	117.2	32.6	10.7							
22.00	2.09	1.67	40.0	0.00	0.0	0.00	0.00	0.10	1.16	2000.00	2.00	2.00
2.00	0.43	0.00	117.4	32.9	10.8							

													0detail
21.94	2.09	1.67	40.0	0.00	0.0	0.00	0.00	0.10	1.16	2000.00	2.00	2.00	2.00
2.00	0.44	0.00	117.7	33.1	10.9								
21.88	2.09	1.67	40.0	0.00	0.0	0.00	0.00	0.10	1.16	2000.00	2.00	2.00	2.00
2.00	0.44	0.00	117.9	33.4	11.0								
21.82	2.09	1.67	40.0	0.00	0.0	0.00	0.00	0.10	1.16	2000.00	2.00	2.00	2.00
2.00	0.44	0.00	118.2	33.6	11.0								
21.76	2.09	1.67	40.0	0.00	0.0	0.00	0.00	0.10	1.16	2000.00	2.00	2.00	2.00
2.00	0.45	0.00	118.4	33.9	11.1								
21.70	2.09	1.67	40.0	0.00	0.0	0.00	0.00	0.10	1.16	2000.00	2.00	2.00	2.00
2.00	0.45	0.00	118.7	34.1	11.2								
21.64	2.09	1.67	40.0	0.00	0.0	0.00	0.00	0.10	1.16	2000.00	2.00	2.00	2.00
2.00	0.45	0.00	118.9	34.4	11.3								
21.58	2.09	1.67	40.0	0.00	0.0	0.00	0.00	0.10	1.16	2000.00	2.00	2.00	2.00
2.00	0.46	0.00	119.2	34.6	11.4								
21.52	2.09	1.67	40.0	0.00	0.0	0.00	0.00	0.10	1.16	2000.00	2.00	2.00	2.00
2.00	0.46	0.00	119.4	34.9	11.5								
21.46	2.09	1.67	40.0	0.00	0.0	0.00	0.00	0.10	1.16	2000.00	2.00	2.00	2.00
2.00	0.46	0.00	119.7	35.1	11.5								
21.40	2.09	1.67	40.0	0.00	0.0	0.00	0.00	0.10	1.16	2000.00	2.00	2.00	2.00
2.00	0.47	0.00	119.9	35.4	11.6								
21.34	2.09	1.67	40.0	0.00	0.0	0.00	0.00	0.10	1.16	2000.00	2.00	2.00	2.00
2.00	0.47	0.00	120.2	35.6	11.7								
21.28	2.09	1.67	40.0	0.00	0.0	0.00	0.00	0.10	1.16	2000.00	2.00	2.00	2.00
2.00	0.47	0.00	120.4	35.9	11.8								
21.22	2.09	1.67	40.0	0.00	0.0	0.00	0.00	0.10	1.16	2000.00	2.00	2.00	2.00
2.00	0.48	0.00	120.7	36.1	11.9								
21.16	2.09	1.67	40.0	0.00	0.0	0.00	0.00	0.10	1.16	2000.00	2.00	2.00	2.00
2.00	0.48	0.00	120.9	36.4	12.0								
21.11	2.09	1.67	40.0	0.00	0.0	0.00	0.00	0.10	1.16	2000.00	2.00	2.00	2.00
2.00	0.48	0.00	121.1	36.6	12.0								
21.05	2.09	1.67	40.0	0.00	0.0	0.00	0.00	0.10	1.16	2000.00	2.00	2.00	2.00
2.00	0.49	0.00	121.4	36.9	12.1								
20.99	2.09	1.67	40.0	0.00	0.0	0.00	0.00	0.10	1.16	2000.00	2.00	2.00	2.00
2.00	0.49	0.00	121.6	37.2	12.2								
20.93	2.09	1.67	40.0	0.00	0.0	0.00	0.00	0.10	1.16	2000.00	2.00	2.00	2.00
2.00	0.49	0.00	121.9	37.4	12.3								
20.87	2.09	1.67	40.0	0.00	0.0	0.00	0.00	0.10	1.16	2000.00	2.00	2.00	2.00
2.00	0.50	0.00	122.1	37.7	12.4								
20.81	2.09	1.67	40.0	0.00	0.0	0.00	0.00	0.10	1.16	2000.00	2.00	2.00	2.00
2.00	0.50	0.00	122.4	37.9	12.5								
20.75	2.09	1.67	40.0	0.00	0.0	0.00	0.00	0.10	1.16	2000.00	2.00	2.00	2.00
2.00	0.50	0.00	122.6	38.2	12.5								
20.69	2.09	1.67	40.0	0.00	0.0	0.00	0.00	0.10	1.16	2000.00	2.00	2.00	2.00
2.00	0.51	0.00	122.9	38.4	12.6								
20.63	2.09	1.67	40.0	0.00	0.0	0.00	0.00	0.10	1.16	2000.00	2.00	2.00	2.00
2.00	0.51	0.00	123.1	38.7	12.7								
20.57	2.09	1.67	40.0	0.00	0.0	0.00	0.00	0.10	1.16	2000.00	2.00	2.00	2.00
2.00	0.51	0.00	123.4	38.9	12.8								
20.51	2.09	1.67	40.0	0.00	0.0	0.00	0.00	0.10	1.16	2000.00	2.00	2.00	2.00
2.00	0.52	0.00	123.6	39.2	12.9								
20.45	2.09	1.67	40.0	0.00	0.0	0.00	0.00	0.10	1.16	2000.00	2.00	2.00	2.00
2.00	0.52	0.00	123.9	39.4	13.0								
20.39	2.09	1.67	40.0	0.00	0.0	0.00	0.00	0.10	1.16	2000.00	2.00	2.00	2.00
2.00	0.52	0.00	124.1	39.7	13.0								
20.33	2.09	1.67	40.0	0.00	0.0	0.00	0.00	0.10	1.16	2000.00	2.00	2.00	2.00
2.00	0.53	0.00	124.4	39.9	13.1								
20.27	2.09	1.67	40.0	0.00	0.0	0.00	0.00	0.10	1.16	2000.00	2.00	2.00	2.00
2.00	0.53	0.00	124.6	40.2	13.2								
20.21	2.09	1.67	40.0	0.00	0.0	0.00	0.00	0.10	1.16	2000.00	2.00	2.00	2.00
2.00	0.53	0.00	124.9	40.4	13.3								
20.15	2.09	1.67	40.0	0.00	0.0	0.00	0.00	0.10	1.16	2000.00	2.00	2.00	2.00
2.00	0.54	0.00	125.1	40.7	13.4								
20.09	2.09	1.67	40.0	0.00	0.0	0.00	0.00	0.10	1.16	2000.00	2.00	2.00	2.00
2.00	0.54	0.00	125.4	40.9	13.5								
20.03	2.09	1.67	40.0	0.00	0.0	0.00	0.00	0.10	1.16	2000.00	2.00	2.00	2.00
2.00	0.54	0.00	125.6	41.2	13.5								
19.97	2.09	1.67	40.0	0.00	0.0	0.00	0.00	0.10	1.16	2000.00	2.00	2.00	2.00

0detail

2.00	0.55	0.00	125.9	41.5	13.6								
19.91	2.09	1.67	40.0	0.00	0.0	0.00	0.00	0.10	1.16	2000.00	2.00	2.00	2.00
2.00	0.55	0.00	126.1	41.7	13.7								
19.85	2.09	1.67	40.0	0.00	0.0	0.00	0.00	0.10	1.16	2000.00	2.00	2.00	2.00
2.00	0.55	0.00	126.4	42.0	13.8								
19.79	2.09	1.67	40.0	0.00	0.0	0.00	0.00	0.10	1.16	2000.00	2.00	2.00	2.00
2.00	0.56	0.00	126.6	42.2	13.9								
19.73	2.09	1.67	40.0	0.00	0.0	0.00	0.00	0.10	1.16	2000.00	2.00	2.00	2.00
2.00	0.56	0.00	126.9	42.5	13.9								
19.67	2.09	1.67	40.0	0.00	0.0	0.00	0.00	0.10	1.16	2000.00	2.00	2.00	2.00
2.00	0.56	0.00	127.1	42.7	14.0								
19.61	2.09	1.67	40.0	0.00	0.0	0.00	0.00	0.10	1.16	2000.00	2.00	2.00	2.00
2.00	0.57	0.00	127.4	43.0	14.1								
19.56	2.09	1.67	40.0	0.00	0.0	0.00	0.00	0.10	1.16	2000.00	2.00	2.00	2.00
2.00	0.57	0.00	127.6	43.2	14.2								
19.50	2.09	1.67	40.0	0.00	0.0	0.00	0.00	0.10	1.16	2000.00	2.00	2.00	2.00
2.00	0.57	0.00	127.9	43.5	14.3								
19.44	2.09	1.67	40.0	0.00	0.0	0.00	0.00	0.10	1.16	2000.00	2.00	2.00	2.00
2.00	0.58	0.00	128.1	43.7	14.4								
19.38	2.09	1.67	40.0	0.00	0.0	0.00	0.00	0.10	1.16	2000.00	2.00	2.00	2.00
2.00	0.58	0.00	128.4	44.0	14.4								
19.32	2.09	1.67	40.0	0.00	0.0	0.00	0.00	0.10	1.16	2000.00	2.00	2.00	2.00
2.00	0.58	0.00	128.6	44.2	14.5								
19.26	2.09	1.67	40.0	0.00	0.0	0.00	0.00	0.10	1.16	2000.00	2.00	2.00	2.00
2.00	0.59	0.00	128.9	44.5	14.6								
19.20	2.09	1.67	40.0	0.00	0.0	0.00	0.00	0.10	1.16	2000.00	2.00	2.00	2.00
2.00	0.59	0.00	129.1	44.7	14.7								
19.14	2.09	1.67	40.0	0.00	0.0	0.00	0.00	0.10	1.16	2000.00	2.00	2.00	2.00
2.00	0.59	0.00	129.4	45.0	14.8								
19.08	2.09	1.67	40.0	0.00	0.0	0.00	0.00	0.10	1.16	2000.00	2.00	2.00	2.00
2.00	0.60	0.00	129.6	45.2	14.9								
19.02	2.09	1.67	40.0	0.00	0.0	0.00	0.00	0.10	1.16	2000.00	2.00	2.00	2.00
2.00	0.60	0.00	129.9	45.5	14.9								
18.96	2.09	1.67	40.0	0.00	0.0	0.00	0.00	0.10	1.16	2000.00	2.00	2.00	2.00
2.00	0.60	0.00	130.1	45.7	15.0								
18.90	2.09	1.67	40.0	0.00	0.0	0.00	0.00	0.10	1.16	2000.00	2.00	2.00	2.00
2.00	0.61	0.00	130.4	46.0	15.1								
18.84	2.09	1.67	40.0	0.00	0.0	0.00	0.00	0.10	1.16	2000.00	2.00	2.00	2.00
2.00	0.61	0.00	130.6	46.3	15.2								
18.78	2.09	1.67	40.0	0.00	0.0	0.00	0.00	0.10	1.16	2000.00	2.00	2.00	2.00
2.00	0.61	0.00	130.9	46.5	15.3								
18.72	2.09	1.67	40.0	0.00	0.0	0.00	0.00	0.10	1.16	2000.00	2.00	2.00	2.00
2.00	0.62	0.00	131.1	46.8	15.4								
18.66	2.09	1.67	40.0	0.00	0.0	0.00	0.00	0.10	1.16	2000.00	2.00	2.00	2.00
2.00	0.62	0.00	131.4	47.0	15.4								
18.60	2.09	1.67	40.0	0.00	0.0	0.00	0.00	0.10	1.16	2000.00	2.00	2.00	2.00
2.00	0.62	0.00	131.6	47.3	15.5								
18.54	2.09	1.67	40.0	0.00	0.0	0.00	0.00	0.10	1.16	2000.00	2.00	2.00	2.00
2.00	0.63	0.00	131.9	47.5	15.6								
18.48	2.09	1.67	40.0	0.00	0.0	0.00	0.00	0.10	1.16	2000.00	2.00	2.00	2.00
2.00	0.63	0.00	132.1	47.8	15.7								
18.42	2.09	1.67	40.0	0.00	0.0	0.00	0.00	0.10	1.16	2000.00	2.00	2.00	2.00
2.00	0.63	0.00	132.4	48.0	15.8								
18.36	2.09	1.67	40.0	0.00	0.0	0.00	0.00	0.10	1.16	2000.00	2.00	2.00	2.00
2.00	0.64	0.00	132.6	48.3	15.9								
18.30	2.09	1.67	40.0	0.00	0.0	0.00	0.00	0.10	1.16	2000.00	2.00	2.00	2.00
2.00	0.64	0.00	132.9	48.5	15.9								
18.24	2.09	1.67	40.0	0.00	0.0	0.00	0.00	0.10	1.16	2000.00	2.00	2.00	2.00
2.00	0.64	0.00	133.1	48.8	16.0								
18.18	2.09	1.67	40.0	0.00	0.0	0.00	0.00	0.10	1.16	2000.00	2.00	2.00	2.00
2.00	0.65	0.00	133.4	49.0	16.1								
18.12	2.09	1.67	40.0	0.00	0.0	0.00	0.00	0.10	1.16	2000.00	2.00	2.00	2.00
2.00	0.65	0.00	133.6	49.3	16.2								
18.06	2.09	1.67	40.0	0.00	0.0	0.00	0.00	0.10	1.16	2000.00	2.00	2.00	2.00
2.00	0.65	0.00	133.9	49.5	16.3								
18.01	2.09	1.67	40.0	0.00	0.0	0.00	0.00	0.10	1.16	2000.00	2.00	2.00	2.00
2.00	0.66	0.00	134.1	49.8	16.4								

													0detail
17.95	2.09	1.67	40.0	0.00	0.0	0.00	0.00	0.10	1.16	2000.00	2.00	2.00	2.00
2.00	0.66	0.00	134.4	50.0	16.4								
17.89	2.09	1.67	40.0	0.00	0.0	0.00	0.00	0.10	1.16	2000.00	2.00	2.00	2.00
2.00	0.66	0.00	134.6	50.3	16.5								
17.83	2.09	1.67	40.0	0.00	0.0	0.00	0.00	0.10	1.16	2000.00	2.00	2.00	2.00
2.00	0.67	0.00	134.9	50.5	16.6								
17.77	2.09	1.67	40.0	0.00	0.0	0.00	0.00	0.10	1.16	2000.00	2.00	2.00	2.00
2.00	0.67	0.00	135.1	50.8	16.7								
17.71	2.09	1.67	40.0	0.00	0.0	0.00	0.00	0.10	1.16	2000.00	2.00	2.00	2.00
2.00	0.67	0.00	135.4	51.1	16.8								
17.65	2.09	1.67	40.0	0.00	0.0	0.00	0.00	0.10	1.16	2000.00	2.00	2.00	2.00
2.00	0.68	0.00	135.6	51.3	16.9								
17.59	2.09	1.67	40.0	0.00	0.0	0.00	0.00	0.10	1.16	2000.00	2.00	2.00	2.00
2.00	0.68	0.00	135.9	51.6	16.9								
17.53	2.09	1.67	40.0	0.00	0.0	0.00	0.00	0.10	1.16	2000.00	2.00	2.00	2.00
2.00	0.68	0.00	136.1	51.8	17.0								
17.47	2.09	1.67	40.0	0.00	0.0	0.00	0.00	0.10	1.16	2000.00	2.00	2.00	2.00
2.00	0.69	0.00	136.4	52.1	17.1								
17.41	2.09	1.67	40.0	0.00	0.0	0.00	0.00	0.10	1.16	2000.00	2.00	2.00	2.00
2.00	0.69	0.00	136.6	52.3	17.2								
17.35	2.09	1.67	40.0	0.00	0.0	0.00	0.00	0.10	1.16	2000.00	2.00	2.00	2.00
2.00	0.69	0.00	136.9	52.6	17.3								
17.29	2.09	1.67	40.0	0.00	0.0	0.00	0.00	0.10	1.16	2000.00	2.00	2.00	2.00
2.00	0.70	0.00	137.1	52.8	17.4								
17.23	2.09	1.67	40.0	0.00	0.0	0.00	0.00	0.10	1.16	2000.00	2.00	2.00	2.00
2.00	0.70	0.00	137.4	53.1	17.4								
17.17	2.09	1.67	40.0	0.00	0.0	0.00	0.00	0.10	1.16	2000.00	2.00	2.00	2.00
2.00	0.70	0.00	137.6	53.3	17.5								
17.11	2.09	1.67	40.0	0.00	0.0	0.00	0.00	0.10	1.16	2000.00	2.00	2.00	2.00
2.00	0.71	0.00	137.9	53.6	17.6								
17.05	2.09	1.67	40.0	0.00	0.0	0.00	0.00	0.10	1.16	2000.00	2.00	2.00	2.00
2.00	0.71	0.00	138.1	53.8	17.7								
16.99	2.09	1.67	40.0	0.00	0.0	0.00	0.00	0.10	1.16	2000.00	2.00	2.00	2.00
2.00	0.71	0.00	138.4	54.1	17.8								
16.93	2.09	1.67	40.0	0.00	0.0	0.00	0.00	0.10	1.16	2000.00	2.00	2.00	2.00
2.00	0.72	0.00	138.6	54.3	17.9								
16.87	2.09	1.67	40.0	0.00	0.0	0.00	0.00	0.10	1.16	2000.00	2.00	2.00	2.00
2.00	0.72	0.00	138.9	54.6	17.9								
16.81	2.09	1.67	40.0	0.00	0.0	0.00	0.00	0.10	1.16	2000.00	2.00	2.00	2.00
2.00	0.72	0.00	139.1	54.8	18.0								
16.75	2.09	1.67	40.0	0.00	0.0	0.00	0.00	0.10	1.16	2000.00	2.00	2.00	2.00
2.00	0.73	0.00	139.4	55.1	18.1								
16.69	2.09	1.67	40.0	0.00	0.0	0.00	0.00	0.10	1.16	2000.00	2.00	2.00	2.00
2.00	0.73	0.00	139.6	55.4	18.2								
16.63	2.09	1.67	40.0	0.00	0.0	0.00	0.00	0.10	1.16	2000.00	2.00	2.00	2.00
2.00	0.73	0.00	139.9	55.6	18.3								
16.57	2.09	1.67	40.0	0.00	0.0	0.00	0.00	0.10	1.16	2000.00	2.00	2.00	2.00
2.00	0.74	0.00	140.1	55.9	18.3								
16.51	2.09	1.67	40.0	0.00	0.0	0.00	0.00	0.10	1.16	2000.00	2.00	2.00	2.00
2.00	0.74	0.00	140.4	56.1	18.4								
16.45	2.09	1.67	40.0	0.00	0.0	0.00	0.00	0.10	1.16	2000.00	2.00	2.00	2.00
2.00	0.74	0.00	140.6	56.4	18.5								
16.40	2.09	1.67	40.0	0.00	0.0	0.00	0.00	0.10	1.16	2000.00	2.00	2.00	2.00
2.00	0.75	0.00	140.9	56.6	18.6								
16.34	2.09	1.67	40.0	0.00	0.0	0.00	0.00	0.10	1.16	2000.00	2.00	2.00	2.00
2.00	0.75	0.00	141.1	56.9	18.7								
16.28	2.09	1.67	40.0	0.00	0.0	0.00	0.00	0.10	1.16	2000.00	2.00	2.00	2.00
2.00	0.75	0.00	141.4	57.1	18.8								
16.22	2.09	1.67	40.0	0.00	0.0	0.00	0.00	0.10	1.16	2000.00	2.00	2.00	2.00
2.00	0.76	0.00	141.6	57.4	18.8								
16.16	2.09	1.67	40.0	0.00	0.0	0.00	0.00	0.10	1.16	2000.00	2.00	2.00	2.00
2.00	0.76	0.00	141.9	57.6	18.9								
16.10	2.09	1.67	40.0	0.00	0.0	0.00	0.00	0.10	1.16	2000.00	2.00	2.00	2.00
2.00	0.76	0.00	142.1	57.9	19.0								
16.04	2.09	1.67	40.0	0.00	0.0	0.00	0.00	0.10	1.16	2000.00	2.00	2.00	2.00
2.00	0.77	0.00	142.3	58.1	19.1								
15.98	2.09	1.67	40.0	0.00	0.0	0.00	0.00	0.10	1.16	2000.00	2.00	2.00	2.00

														Ødetail			
2.00	0.77	0.00	142.6	58.4	19.2												
15.92	2.09	1.67	40.0	0.00	0.0	0.00	0.00	0.10	1.16	2000.00	2.00	2.00	2.00				
2.00	0.77	0.00	142.8	58.6	19.3												
15.86	2.09	1.67	40.0	0.00	0.0	0.00	0.00	0.10	1.16	2000.00	2.00	2.00	2.00				
2.00	0.78	0.00	143.1	58.9	19.3												
15.80	2.09	1.67	40.0	0.00	0.0	0.00	0.00	0.10	1.16	2000.00	2.00	2.00	2.00				
2.00	0.78	0.00	143.3	59.1	19.4												
15.74	2.09	1.67	40.0	0.00	0.0	0.00	0.00	0.10	1.16	2000.00	2.00	2.00	2.00				
2.00	0.78	0.00	143.6	59.4	19.5												
15.68	2.09	1.67	40.0	0.00	0.0	0.00	0.00	0.10	1.16	2000.00	2.00	2.00	2.00				
2.00	0.79	0.00	143.8	59.6	19.6												
15.62	2.09	1.67	40.0	0.00	0.0	0.00	0.00	0.10	1.16	2000.00	2.00	2.00	2.00				
2.00	0.79	0.00	144.1	59.9	19.7												
15.56	2.09	1.67	40.0	0.00	0.0	0.00	0.00	0.10	1.16	2000.00	2.00	2.00	2.00				
2.00	0.79	0.00	144.3	60.2	19.8												
15.50	2.09	1.67	40.0	0.00	0.0	0.00	0.00	0.10	1.16	2000.00	2.00	2.00	2.00				
2.00	0.80	0.00	144.6	60.4	19.8												
15.44	2.09	1.67	40.0	0.00	0.0	0.00	0.00	0.10	1.16	2000.00	2.00	2.00	2.00				
2.00	0.80	0.00	144.8	60.7	19.9												
15.38	2.09	1.67	40.0	0.00	0.0	0.00	0.00	0.10	1.16	2000.00	2.00	2.00	2.00				
2.00	0.80	0.00	145.1	60.9	20.0												
15.32	2.09	1.67	40.0	0.00	0.0	0.00	0.00	0.10	1.16	2000.00	2.00	2.00	2.00				
2.00	0.81	0.00	145.3	61.2	20.1												
15.26	2.09	1.67	40.0	0.00	0.0	0.00	0.00	0.10	1.16	2000.00	2.00	2.00	2.00				
2.00	0.81	0.00	145.6	61.4	20.2												
15.20	2.09	1.67	40.0	0.00	0.0	0.00	0.00	0.10	1.16	2000.00	2.00	2.00	2.00				
2.00	0.81	0.00	145.8	61.7	20.3												
15.14	2.09	1.67	40.0	0.00	0.0	0.00	0.00	0.10	1.16	2000.00	2.00	2.00	2.00				
2.00	0.82	0.00	146.1	61.9	20.3												
15.08	2.09	1.67	40.0	0.00	0.0	0.00	0.00	0.10	1.16	2000.00	2.00	2.00	2.00				
2.00	0.82	0.00	146.3	62.2	20.4												
15.02	2.09	1.67	40.0	0.00	0.0	0.00	0.00	0.10	1.16	2000.00	2.00	2.00	2.00				
2.00	0.82	0.00	146.6	62.4	20.5												
14.96	2.09	1.67	40.0	0.00	0.0	0.00	0.00	0.10	1.16	2000.00	2.00	2.00	2.00				
2.00	0.83	0.00	146.8	62.7	20.6												
14.90	2.09	1.67	40.0	0.00	0.0	0.00	0.00	0.10	1.16	2000.00	2.00	2.00	2.00				
2.00	0.83	0.00	147.1	62.9	20.7												
14.85	2.09	1.67	40.0	0.00	0.0	0.00	0.00	0.10	1.16	2000.00	2.00	2.00	2.00				
2.00	0.83	0.00	147.3	63.2	20.8												
14.79	2.09	1.67	40.0	0.00	0.0	0.00	0.00	0.10	1.16	2000.00	2.00	2.00	2.00				
2.00	0.84	0.00	147.6	63.4	20.8												
14.73	2.09	1.67	40.0	0.00	0.0	0.00	0.00	0.10	1.16	2000.00	2.00	2.00	2.00				
2.00	0.84	0.00	147.8	63.7	20.9												
14.67	2.09	1.67	40.0	0.00	0.0	0.00	0.00	0.10	1.16	2000.00	2.00	2.00	2.00				
2.00	0.84	0.00	148.1	63.9	21.0												
14.61	2.09	1.67	40.0	0.00	0.0	0.00	0.00	0.10	1.16	2000.00	2.00	2.00	2.00				
2.00	0.85	0.00	148.3	64.2	21.1												
14.55	2.09	1.67	40.0	0.00	0.0	0.00	0.00	0.10	1.16	2000.00	2.00	2.00	2.00				
2.00	0.85	0.00	148.6	64.5	21.2												
14.49	2.09	1.67	40.0	0.00	0.0	0.00	0.00	0.10	1.16	2000.00	2.00	2.00	2.00				
2.00	0.85	0.00	148.8	64.7	21.3												
14.43	2.09	1.67	40.0	0.00	0.0	0.00	0.00	0.10	1.16	2000.00	2.00	2.00	2.00				
2.00	0.86	0.00	149.1	65.0	21.3												
14.37	2.09	1.67	40.0	0.00	0.0	0.00	0.00	0.10	1.16	2000.00	2.00	2.00	2.00				
2.00	0.86	0.00	149.3	65.2	21.4												
14.31	2.09	1.67	40.0	0.00	0.0	0.00	0.00	0.10	1.16	2000.00	2.00	2.00	2.00				
2.00	0.86	0.00	149.6	65.5	21.5												
14.25	2.09	1.67	40.0	0.00	0.0	0.00	0.00	0.10	1.16	2000.00	2.00	2.00	2.00				
2.00	0.87	0.00	149.8	65.7	21.6												
14.19	2.09	1.67	40.0	0.00	0.0	0.00	0.00	0.10	1.16	2000.00	2.00	2.00	2.00				
2.00	0.87	0.00	150.1	66.0	21.7												
14.13	2.09	1.67	40.0	0.00	0.0	0.00	0.00	0.10	1.16	2000.00	2.00	2.00	2.00				
2.00	0.87	0.00	150.3	66.2	21.8												
14.07	2.09	1.67	40.0	0.00	0.0	0.00	0.00	0.10	1.16	2000.00	2.00	2.00	2.00				
2.00	0.88	0.00	150.6	66.5	21.8												
14.01	2.09	1.67	40.0	0.00	0.0	0.00	0.00	0.10	1.16	2000.00	2.00	2.00	2.00				
2.00	0.88	0.00	150.8	66.7	21.9												

													0detail
13.95	2.09	1.67	40.0	0.00	0.0	0.00	0.00	0.10	1.16	2000.00	2.00	2.00	2.00
2.00	0.88	0.00	151.1	67.0	22.0								
13.89	2.09	1.67	40.0	0.00	0.0	0.00	0.00	0.10	1.16	2000.00	2.00	2.00	2.00
2.00	0.89	0.00	151.3	67.2	22.1								
13.83	2.09	1.67	40.0	0.00	0.0	0.00	0.00	0.10	1.16	2000.00	2.00	2.00	2.00
2.00	0.89	0.00	151.6	67.5	22.2								
13.77	2.09	1.67	40.0	0.00	0.0	0.00	0.00	0.10	1.16	2000.00	2.00	2.00	2.00
2.00	0.89	0.00	151.8	67.7	22.3								
13.71	2.09	1.67	40.0	0.00	0.0	0.00	0.00	0.10	1.16	2000.00	2.00	2.00	2.00
2.00	0.90	0.00	152.1	68.0	22.3								
13.65	2.09	1.67	40.0	0.00	0.0	0.00	0.00	0.10	1.16	2000.00	2.00	2.00	2.00
2.00	0.90	0.00	152.3	68.2	22.4								
13.59	2.09	1.67	40.0	0.00	0.0	0.00	0.00	0.10	1.16	2000.00	2.00	2.00	2.00
2.00	0.90	0.00	152.6	68.5	22.5								
13.53	2.09	1.67	40.0	0.00	0.0	0.00	0.00	0.10	1.16	2000.00	2.00	2.00	2.00
2.00	0.91	0.00	152.8	68.7	22.6								
13.47	2.09	1.67	40.0	0.00	0.0	0.00	0.00	0.10	1.16	2000.00	2.00	2.00	2.00
2.00	0.91	0.00	153.1	69.0	22.7								
13.41	2.09	1.67	40.0	0.00	0.0	0.00	0.00	0.10	1.16	2000.00	2.00	2.00	2.00
2.00	0.91	0.00	153.3	69.3	22.7								
13.35	2.09	1.67	40.0	0.00	0.0	0.00	0.00	0.10	1.16	2000.00	2.00	2.00	2.00
2.00	0.92	0.00	153.6	69.5	22.8								
13.30	2.09	1.67	40.0	0.00	0.0	0.00	0.00	0.10	1.16	2000.00	2.00	2.00	2.00
2.00	0.92	0.00	153.8	69.8	22.9								
13.24	2.09	1.66	40.0	0.00	0.0	0.00	0.00	0.10	1.16	2000.00	2.00	2.00	2.00
2.00	0.92	0.00	154.1	70.0	23.0								
13.18	2.09	1.66	40.0	0.00	0.0	0.00	0.00	0.10	1.16	2000.00	2.00	2.00	2.00
2.00	0.93	0.00	154.3	70.3	23.1								
13.12	2.09	1.65	40.0	0.00	0.0	0.00	0.00	0.10	1.16	2000.00	2.00	2.00	2.00
2.00	0.93	0.00	154.6	70.5	23.2								
13.06	2.09	1.64	40.0	0.00	0.0	0.00	0.00	0.10	1.16	2000.00	2.00	2.00	2.00
2.00	0.93	0.00	154.8	70.8	23.2								
13.00	2.09	1.63	40.0	0.00	0.0	0.00	0.00	0.10	1.16	2000.00	2.00	2.00	2.00
2.00	0.94	0.00	155.1	71.0	23.3								
12.94	2.09	1.63	40.0	0.00	0.0	0.00	0.00	0.10	1.16	2000.00	2.00	2.00	2.00
2.00	0.94	0.00	155.3	71.3	23.4								
12.88	2.09	1.62	40.0	0.00	0.0	0.00	0.00	0.10	1.16	2000.00	2.00	2.00	2.00
2.00	0.94	0.00	155.6	71.5	23.5								
12.82	2.09	1.61	40.0	0.00	0.0	0.00	0.00	0.10	1.16	2000.00	2.00	2.00	2.00
2.00	0.95	0.00	155.8	71.8	23.6								
12.76	2.09	1.60	40.0	0.00	0.0	0.00	0.00	0.10	1.16	2000.00	2.00	2.00	2.00
2.00	0.95	0.00	156.1	72.0	23.7								
12.70	2.09	1.59	40.0	0.00	0.0	0.00	0.00	0.10	1.16	2000.00	2.00	2.00	2.00
2.00	0.95	0.00	156.3	72.3	23.7								
12.64	2.09	1.59	40.0	0.00	0.0	0.00	0.00	0.10	1.16	2000.00	2.00	2.00	2.00
2.00	0.96	0.00	156.6	72.5	23.8								
12.58	2.09	1.58	40.0	0.00	0.0	0.00	0.00	0.10	1.16	2000.00	2.00	2.00	2.00
2.00	0.96	0.00	156.8	72.8	23.9								
12.52	2.09	1.57	40.0	0.00	0.0	0.00	0.00	0.10	1.16	2000.00	2.00	2.00	2.00
2.00	0.96	0.00	157.1	73.0	24.0								
12.46	2.09	1.56	40.0	0.00	0.0	0.00	0.00	0.10	1.16	2000.00	2.00	2.00	2.00
2.00	0.97	0.00	157.3	73.3	24.1								
12.40	2.09	1.56	40.0	0.00	0.0	0.00	0.00	0.10	1.16	2000.00	2.00	2.00	2.00
2.00	0.97	0.00	157.6	73.5	24.2								
12.34	2.09	1.55	40.0	0.00	0.0	0.00	0.00	0.10	1.16	2000.00	2.00	2.00	2.00
2.00	0.97	0.00	157.8	73.8	24.2								
12.28	2.09	1.54	40.0	0.00	0.0	0.00	0.00	0.10	1.16	2000.00	2.00	2.00	2.00
2.00	0.98	0.00	158.1	74.1	24.3								
12.22	2.09	1.53	40.0	0.00	0.0	0.00	0.00	0.10	1.16	2000.00	2.00	2.00	2.00
2.00	0.98	0.00	158.3	74.3	24.4								
12.16	2.09	1.52	40.0	0.00	0.0	0.00	0.00	0.10	1.16	2000.00	2.00	2.00	2.00
2.00	0.98	0.00	158.6	74.6	24.5								
12.10	2.09	1.52	40.0	0.00	0.0	0.00	0.00	0.10	1.16	2000.00	2.00	2.00	2.00
2.00	0.99	0.00	158.8	74.8	24.6								
12.04	2.09	1.51	40.0	0.00	0.0	0.00	0.00	0.10	1.16	2000.00	2.00	2.00	2.00
2.00	0.99	0.00	159.1	75.1	24.7								
11.98	2.09	1.50	40.0	0.00	0.0	0.00	0.00	0.10	1.16	2000.00	2.00	2.00	2.00

0detail

2.00	0.99	0.00	159.3	75.3	24.7								
11.92	2.09	1.49	40.0	0.00	0.0	0.00	0.00	0.10	1.16	2000.00	2.00	2.00	2.00
2.00	1.00	0.00	159.6	75.6	24.8								
11.86	2.09	1.49	40.0	0.00	0.0	0.00	0.00	0.10	1.16	2000.00	2.00	2.00	2.00
2.00	1.00	0.00	159.8	75.8	24.9								
11.80	2.09	1.48	40.0	0.00	0.0	0.00	0.00	0.10	1.16	2000.00	2.00	2.00	2.00
2.00	1.00	0.00	160.1	76.1	25.0								
11.74	2.09	1.47	40.0	0.00	0.0	0.00	0.00	0.10	1.16	2000.00	2.00	2.00	2.00
2.00	1.01	0.00	160.3	76.3	25.1								
11.69	2.09	1.46	40.0	0.00	0.0	0.00	0.00	0.10	1.16	2000.00	2.00	2.00	2.00
2.00	1.01	0.00	160.6	76.6	25.2								
11.63	2.09	1.45	40.0	0.00	0.0	0.00	0.00	0.10	1.16	2000.00	2.00	2.00	2.00
2.00	1.01	0.00	160.8	76.8	25.2								
11.57	2.09	1.45	40.0	0.00	0.0	0.00	0.00	0.10	1.16	2000.00	2.00	2.00	2.00
2.00	1.02	0.00	161.1	77.1	25.3								
11.51	2.09	1.44	40.0	0.00	0.0	0.00	0.00	0.10	1.16	2000.00	2.00	2.00	2.00
2.00	1.02	0.00	161.3	77.3	25.4								
11.45	2.09	1.43	40.0	0.00	0.0	0.00	0.00	0.10	1.16	2000.00	2.00	2.00	2.00
2.00	1.02	0.00	161.6	77.6	25.5								
11.39	2.09	1.42	40.0	0.00	0.0	0.00	0.00	0.10	1.16	2000.00	2.00	2.00	2.00
2.00	1.03	0.00	161.8	77.8	25.6								
11.33	2.09	1.42	40.0	0.00	0.0	0.00	0.00	0.10	1.16	2000.00	2.00	2.00	2.00
2.00	1.03	0.00	162.1	78.1	25.7								
11.27	2.09	1.41	40.0	0.00	0.0	0.00	0.00	0.10	1.16	2000.00	2.00	2.00	2.00
2.00	1.03	0.00	162.3	78.4	25.7								
11.21	2.09	1.40	40.0	0.00	0.0	0.00	0.00	0.10	1.16	2000.00	2.00	2.00	2.00
2.00	1.04	0.00	162.6	78.6	25.8								
11.15	2.09	1.39	40.0	0.00	0.0	0.00	0.00	0.10	1.16	2000.00	2.00	2.00	2.00
2.00	1.04	0.00	162.8	78.9	25.9								
11.09	2.09	1.38	40.0	0.00	0.0	0.00	0.00	0.10	1.16	2000.00	2.00	2.00	2.00
2.00	1.05	0.00	163.0	79.1	26.0								
11.03	2.09	1.38	40.0	0.00	0.0	0.00	0.00	0.10	1.16	2000.00	2.00	2.00	2.00
2.00	1.05	0.00	163.3	79.4	26.1								
10.97	2.09	1.37	40.0	0.00	0.0	0.00	0.00	0.10	1.16	2000.00	2.00	2.00	2.00
2.00	1.05	0.00	163.5	79.6	26.2								
10.91	2.09	1.36	40.0	0.00	0.0	0.00	0.00	0.10	1.16	2000.00	2.00	2.00	2.00
2.00	1.06	0.00	163.8	79.9	26.2								
10.85	2.09	1.35	40.0	0.00	0.0	0.00	0.00	0.10	1.16	2000.00	2.00	2.00	2.00
2.00	1.06	0.00	164.0	80.1	26.3								
10.79	2.09	1.35	40.0	0.00	0.0	0.00	0.00	0.10	1.16	2000.00	2.00	2.00	2.00
2.00	1.06	0.00	164.3	80.4	26.4								
10.73	2.09	1.34	40.0	0.00	0.0	0.00	0.00	0.10	1.16	2000.00	2.00	2.00	2.00
2.00	1.07	0.00	164.5	80.6	26.5								
10.67	2.09	1.33	40.0	0.00	0.0	0.00	0.00	0.10	1.16	2000.00	2.00	2.00	2.00
2.00	1.07	0.00	164.8	80.9	26.6								
10.61	2.09	1.32	40.0	0.00	0.0	0.00	0.00	0.10	1.16	2000.00	2.00	2.00	2.00
2.00	1.07	0.00	165.0	81.1	26.7								
10.55	2.09	1.32	40.0	0.00	0.0	0.00	0.00	0.10	1.16	2000.00	2.00	2.00	2.00
2.00	1.08	0.00	165.3	81.4	26.7								
10.49	2.09	1.31	40.0	0.00	0.0	0.00	0.00	0.10	1.16	2000.00	2.00	2.00	2.00
2.00	1.08	0.00	165.5	81.6	26.8								
10.43	2.09	1.30	40.0	0.00	0.0	0.00	0.00	0.10	1.16	2000.00	2.00	2.00	2.00
2.00	1.08	0.00	165.8	81.9	26.9								
10.37	2.09	1.29	40.0	0.00	0.0	0.00	0.00	0.10	1.16	2000.00	2.00	2.00	2.00
2.00	1.09	0.00	166.0	82.1	27.0								
10.31	2.09	1.28	40.0	0.00	0.0	0.00	0.00	0.10	1.16	2000.00	2.00	2.00	2.00
2.00	1.09	0.00	166.3	82.4	27.1								
10.25	2.09	1.28	40.0	0.00	0.0	0.00	0.00	0.10	1.16	2000.00	2.00	2.00	2.00
2.00	1.09	0.00	166.5	82.6	27.1								
10.19	2.09	1.27	40.0	0.00	0.0	0.00	0.00	0.10	1.16	2000.00	2.00	2.00	2.00
2.00	1.10	0.00	166.8	82.9	27.2								
10.14	2.09	1.26	40.0	0.00	0.0	0.00	0.00	0.10	1.16	2000.00	2.00	2.00	2.00
2.00	1.10	0.00	167.0	83.2	27.3								
10.08	2.09	1.25	40.0	0.00	0.0	0.00	0.00	0.10	1.16	2000.00	2.00	2.00	2.00
2.00	1.10	0.00	167.3	83.4	27.4								
10.02	2.09	1.25	40.0	0.00	0.0	0.00	0.00	0.10	1.16	2000.00	2.00	2.00	2.00
2.00	1.11	0.00	167.5	83.7	27.5								

													Ødetail	
9.96	2.09	1.24	40.0	0.00	0.0	0.00	0.00	0.10	1.16	2000.00	2.00	2.00	2.00	
2.00	1.11	0.00	167.8	83.9	27.6									
9.90	2.09	1.23	40.0	0.00	0.0	0.00	0.00	0.10	1.16	2000.00	2.00	2.00	2.00	
2.00	1.11	0.00	168.0	84.2	27.6									
9.84	2.09	1.22	40.0	0.00	0.0	0.00	0.00	0.10	1.16	2000.00	2.00	2.00	2.00	
2.00	1.12	0.00	168.3	84.4	27.7									
9.78	2.09	1.21	40.0	0.00	0.0	0.00	0.00	0.10	1.16	2000.00	2.00	2.00	2.00	
2.00	1.12	0.00	168.5	84.7	27.8									
9.72	1.46	1.21	40.0	20.00	20.0	0.44	0.44	0.10	1.16	1.00	0.12	0.12	0.56	
0.56	1.12	0.00	168.6	84.7	27.8									
9.66	1.46	1.20	40.0	20.00	20.0	0.44	0.44	0.10	1.16	1.00	0.12	0.12	0.55	
0.55	1.12	0.00	168.6	84.8	27.8									
9.60	1.46	1.19	40.0	20.00	20.0	0.43	0.43	0.10	1.16	1.00	0.12	0.12	0.55	
0.55	1.12	0.00	168.7	84.8	27.8									
9.54	1.46	1.18	40.0	20.00	20.0	0.43	0.43	0.10	1.16	1.00	0.12	0.12	0.55	
0.55	1.13	0.00	168.7	84.9	27.9									
9.48	1.46	1.18	40.0	20.00	20.0	0.43	0.43	0.10	1.16	1.00	0.12	0.12	0.54	
0.54	1.13	0.00	168.8	84.9	27.9									
9.42	1.46	1.17	40.0	20.00	20.0	0.43	0.43	0.10	1.16	1.00	0.12	0.12	0.54	
0.54	1.13	0.00	168.8	85.0	27.9									
9.36	1.46	1.16	40.0	20.00	20.0	0.42	0.42	0.10	1.16	1.00	0.12	0.12	0.54	
0.54	1.13	0.00	168.9	85.0	27.9									
9.30	1.46	1.15	40.0	20.00	20.0	0.42	0.42	0.10	1.16	1.00	0.12	0.12	0.54	
0.54	1.14	0.00	168.9	85.1	27.9									
9.24	1.46	1.14	40.0	20.00	20.0	0.42	0.42	0.10	1.16	1.00	0.12	0.12	0.53	
0.53	1.14	0.00	169.0	85.1	27.9									
9.18	1.46	1.14	40.0	20.00	20.0	0.41	0.41	0.10	1.16	1.00	0.12	0.12	0.53	
0.53	1.14	0.00	169.0	85.2	27.9									
9.12	1.46	1.13	40.0	20.00	20.0	0.41	0.41	0.10	1.16	1.00	0.12	0.12	0.53	
0.53	1.14	0.00	169.1	85.2	27.9									
9.06	1.46	1.12	40.0	20.00	20.0	0.41	0.41	0.10	1.16	1.00	0.12	0.12	0.52	
0.52	1.14	0.00	169.1	85.3	27.9									
9.00	1.46	1.11	40.0	20.00	20.0	0.41	0.41	0.10	1.16	1.00	0.12	0.12	0.52	
0.52	1.15	0.00	169.1	85.3	28.0									
8.94	1.46	1.11	40.0	20.00	20.0	0.40	0.40	0.10	1.16	1.00	0.12	0.12	0.52	
0.52	1.15	0.00	169.2	85.4	28.0									
8.88	1.46	1.10	40.0	20.00	20.0	0.40	0.40	0.10	1.16	1.00	0.12	0.12	0.52	
0.52	1.15	0.00	169.2	85.4	28.0									
8.82	1.46	1.09	40.0	20.00	20.0	0.40	0.40	0.10	1.16	1.00	0.12	0.12	0.51	
0.51	1.15	0.00	169.3	85.4	28.0									
8.76	1.46	1.08	40.0	20.00	20.0	0.39	0.39	0.10	1.16	1.00	0.12	0.12	0.51	
0.51	1.15	0.00	169.3	85.5	28.0									
8.70	1.46	1.07	40.0	20.00	20.0	0.39	0.39	0.10	1.16	1.00	0.12	0.12	0.51	
0.51	1.16	0.00	169.4	85.5	28.0									
8.64	1.46	1.07	40.0	20.00	20.0	0.39	0.39	0.10	1.16	1.00	0.12	0.12	0.50	
0.50	1.16	0.00	169.4	85.6	28.0									
8.59	1.46	1.06	40.0	20.00	20.0	0.39	0.39	0.10	1.16	1.00	0.12	0.12	0.50	
0.50	1.16	0.00	169.5	85.6	28.0									
8.53	1.46	1.05	40.0	20.00	20.0	0.38	0.38	0.10	1.16	1.00	0.12	0.12	0.50	
0.50	1.16	0.00	169.5	85.7	28.0									
8.47	1.46	1.04	40.0	20.00	20.0	0.38	0.38	0.10	1.16	1.00	0.12	0.12	0.50	
0.50	1.16	0.00	169.5	85.7	28.0									
8.41	1.46	1.04	40.0	20.00	20.0	0.38	0.38	0.10	1.16	1.00	0.12	0.12	0.49	
0.49	1.17	0.00	169.6	85.8	28.1									
8.35	1.46	1.03	40.0	20.00	20.0	0.37	0.37	0.10	1.16	1.00	0.12	0.12	0.49	
0.49	1.17	0.00	169.6	85.8	28.1									
8.29	1.46	1.02	40.0	20.00	20.0	0.37	0.37	0.10	1.16	1.00	0.12	0.12	0.49	
0.49	1.17	0.00	169.7	85.9	28.1									
8.23	1.46	1.01	40.0	20.00	20.0	0.37	0.37	0.10	1.16	1.00	0.12	0.12	0.49	
0.49	1.17	0.00	169.7	85.9	28.1									
8.17	1.46	1.01	40.0	20.00	20.0	0.37	0.37	0.10	1.16	1.00	0.12	0.12	0.48	
0.48	1.17	0.00	169.8	85.9	28.1									
8.11	1.46	1.00	40.0	20.00	20.0	0.36	0.36	0.10	1.16	1.00	0.12	0.12	0.48	
0.48	1.18	0.00	169.8	86.0	28.1									
8.05	1.46	0.99	40.0	20.00	20.0	0.36	0.36	0.10	1.16	1.00	0.12	0.12	0.48	
0.48	1.18	0.00	169.8	86.0	28.1									
7.99	1.46	0.98	40.0	20.00	20.0	0.36	0.36	0.10	1.16	1.00	0.12	0.12	0.47	

Ødetail

0.47	1.18	0.00	169.9	86.1	28.1								
7.93	1.46	0.97	40.0	20.00	20.0	0.35	0.35	0.10	1.16	1.00	0.12	0.12	0.47
0.47	1.18	0.00	169.9	86.1	28.1								
7.87	1.46	0.97	40.0	20.00	20.0	0.35	0.35	0.10	1.16	1.00	0.12	0.12	0.47
0.47	1.19	0.00	170.0	86.2	28.1								
7.81	1.46	0.96	40.0	20.00	20.0	0.35	0.35	0.10	1.16	1.00	0.12	0.12	0.47
0.47	1.19	0.00	170.0	86.2	28.2								
7.75	1.46	0.95	40.0	20.00	20.0	0.35	0.35	0.10	1.16	1.00	0.12	0.12	0.46
0.46	1.19	0.00	170.0	86.2	28.2								
7.69	1.46	0.94	40.0	20.00	20.0	0.34	0.34	0.10	1.16	1.00	0.12	0.12	0.46
0.46	1.19	0.00	170.1	86.3	28.2								
7.63	1.46	0.94	40.0	20.00	20.0	0.34	0.34	0.10	1.16	1.00	0.12	0.12	0.46
0.46	1.19	0.00	170.1	86.3	28.2								
7.57	1.46	0.93	40.0	20.00	20.0	0.34	0.34	0.10	1.16	1.00	0.12	0.12	0.45
0.45	1.20	0.00	170.2	86.4	28.2								
7.51	1.46	0.92	40.0	20.00	20.0	0.33	0.33	0.10	1.16	1.00	0.12	0.12	0.45
0.45	1.20	0.00	170.2	86.4	28.2								
7.45	1.46	0.91	40.0	20.00	20.0	0.33	0.33	0.10	1.16	1.00	0.12	0.12	0.45
0.45	1.20	0.00	170.2	86.5	28.2								
7.39	1.46	0.90	40.0	20.00	20.0	0.33	0.33	0.10	1.16	1.00	0.12	0.12	0.45
0.45	1.20	0.00	170.3	86.5	28.2								
7.33	1.46	0.90	40.0	20.00	20.0	0.33	0.33	0.10	1.16	1.00	0.12	0.12	0.44
0.44	1.20	0.00	170.3	86.5	28.2								
7.27	1.46	0.89	40.0	20.00	20.0	0.32	0.32	0.10	1.16	1.00	0.12	0.12	0.44
0.44	1.21	0.00	170.4	86.6	28.2								
7.21	1.46	0.88	40.0	20.00	20.0	0.32	0.32	0.10	1.16	1.00	0.12	0.12	0.44
0.44	1.21	0.00	170.4	86.6	28.2								
7.15	1.46	0.87	40.0	20.00	20.0	0.32	0.32	0.10	1.16	1.00	0.12	0.12	0.43
0.43	1.21	0.00	170.4	86.7	28.3								
7.09	1.46	0.87	40.0	20.00	20.0	0.32	0.32	0.10	1.16	1.00	0.12	0.12	0.43
0.43	1.21	0.00	170.5	86.7	28.3								
7.04	1.46	0.86	40.0	20.00	20.0	0.31	0.31	0.10	1.16	1.00	0.12	0.12	0.43
0.43	1.21	0.00	170.5	86.7	28.3								
6.98	1.46	0.85	40.0	20.00	20.0	0.31	0.31	0.10	1.16	1.00	0.12	0.12	0.43
0.43	1.22	0.00	170.5	86.8	28.3								
6.92	1.46	0.84	40.0	20.00	20.0	0.31	0.31	0.10	1.16	1.00	0.12	0.12	0.42
0.42	1.22	0.00	170.6	86.8	28.3								
6.86	1.46	0.83	40.0	20.00	20.0	0.30	0.30	0.10	1.16	1.00	0.12	0.12	0.42
0.42	1.22	0.00	170.6	86.9	28.3								
6.80	1.46	0.83	40.0	20.00	20.0	0.30	0.30	0.10	1.16	1.00	0.12	0.12	0.42
0.42	1.22	0.00	170.7	86.9	28.3								
6.74	1.46	0.82	40.0	20.00	20.0	0.30	0.30	0.10	1.16	1.00	0.12	0.12	0.41
0.41	1.22	0.00	170.7	86.9	28.3								
6.68	1.46	0.81	40.0	20.00	20.0	0.30	0.30	0.10	1.16	1.00	0.12	0.12	0.41
0.41	1.23	0.00	170.7	87.0	28.3								
6.62	1.46	0.80	40.0	20.00	20.0	0.29	0.29	0.10	1.16	1.00	0.12	0.12	0.41
0.41	1.23	0.00	170.8	87.0	28.3								
6.56	1.46	0.80	40.0	20.00	20.0	0.29	0.29	0.10	1.16	1.00	0.12	0.12	0.41
0.41	1.23	0.00	170.8	87.0	28.3								
6.50	1.46	0.79	40.0	20.00	20.0	0.29	0.29	0.10	1.16	1.00	0.12	0.12	0.40
0.40	1.23	0.00	170.8	87.1	28.3								
6.44	1.46	0.78	40.0	20.00	20.0	0.28	0.28	0.10	1.16	1.00	0.12	0.12	0.40
0.40	1.24	0.00	170.9	87.1	28.4								
6.38	1.46	0.77	40.0	20.00	20.0	0.28	0.28	0.10	1.16	1.00	0.12	0.12	0.40
0.40	1.24	0.00	170.9	87.2	28.4								
6.32	1.46	0.76	40.0	20.00	20.0	0.28	0.28	0.10	1.16	1.00	0.12	0.12	0.39
0.39	1.24	0.00	170.9	87.2	28.4								
6.26	1.46	0.76	40.0	20.00	20.0	0.28	0.28	0.10	1.16	1.00	0.12	0.12	0.39
0.39	1.24	0.00	171.0	87.2	28.4								
6.20	1.46	0.75	40.0	20.00	20.0	0.27	0.27	0.10	1.16	1.00	0.12	0.12	0.39
0.39	1.24	0.00	171.0	87.3	28.4								
6.14	1.46	0.74	40.0	20.00	20.0	0.27	0.27	0.10	1.16	1.00	0.12	0.12	0.39
0.39	1.25	0.00	171.0	87.3	28.4								
6.08	1.46	0.73	40.0	20.00	20.0	0.27	0.27	0.10	1.16	1.00	0.12	0.12	0.38
0.38	1.25	0.00	171.1	87.3	28.4								
6.02	1.46	0.73	40.0	20.00	20.0	0.26	0.26	0.10	1.16	1.00	0.12	0.12	0.38
0.38	1.25	0.00	171.1	87.4	28.4								

													0detail
5.96	1.46	0.72	30.0	20.00	20.0	0.26	0.26	0.10	1.16	1.00	0.12	0.12	0.38
0.38	1.25	0.00	171.1	87.4	28.4								
5.90	1.46	0.71	30.0	20.00	20.0	0.26	0.26	0.10	1.16	1.00	0.12	0.12	0.38
0.38	1.25	0.00	171.2	87.4	28.4								
5.84	1.46	0.70	30.0	20.00	20.0	0.26	0.26	0.10	1.16	1.00	0.12	0.12	0.37
0.37	1.26	0.00	171.2	87.5	28.4								
5.78	1.46	0.70	30.0	20.00	20.0	0.25	0.25	0.10	1.16	1.00	0.12	0.12	0.37
0.37	1.26	0.00	171.2	87.5	28.4								
5.72	1.46	0.69	30.0	20.00	20.0	0.25	0.25	0.10	1.16	1.00	0.12	0.12	0.37
0.37	1.26	0.00	171.3	87.5	28.4								
5.66	1.46	0.68	30.0	20.00	20.0	0.25	0.25	0.10	1.16	1.00	0.12	0.12	0.37
0.37	1.26	0.00	171.3	87.6	28.5								
5.60	1.46	0.68	30.0	20.00	20.0	0.25	0.25	0.10	1.16	1.00	0.12	0.12	0.36
0.36	1.26	0.00	171.3	87.6	28.5								
5.54	1.46	0.67	30.0	20.00	20.0	0.24	0.24	0.10	1.16	1.00	0.12	0.12	0.36
0.36	1.27	0.00	171.4	87.6	28.5								
5.48	1.46	0.66	30.0	20.00	20.0	0.24	0.24	0.10	1.16	1.00	0.12	0.12	0.36
0.36	1.27	0.00	171.4	87.7	28.5								
5.43	1.46	0.65	30.0	20.00	20.0	0.24	0.24	0.10	1.16	1.00	0.12	0.12	0.35
0.35	1.27	0.00	171.4	87.7	28.5								
5.37	1.46	0.65	30.0	20.00	20.0	0.24	0.24	0.10	1.16	1.00	0.12	0.12	0.35
0.35	1.27	0.00	171.5	87.7	28.5								
5.31	1.46	0.64	30.0	20.00	20.0	0.23	0.23	0.10	1.16	1.00	0.12	0.12	0.35
0.35	1.27	0.00	171.5	87.8	28.5								
5.25	1.46	0.63	30.0	20.00	20.0	0.23	0.23	0.10	1.16	1.00	0.12	0.12	0.35
0.35	1.28	0.00	171.5	87.8	28.5								
5.19	1.46	0.63	30.0	20.00	20.0	0.23	0.23	0.10	1.16	1.00	0.12	0.12	0.34
0.34	1.28	0.00	171.5	87.8	28.5								
5.13	1.46	0.62	30.0	20.00	20.0	0.23	0.23	0.10	1.16	1.00	0.12	0.12	0.34
0.34	1.28	0.00	171.6	87.9	28.5								
5.07	1.46	0.61	30.0	20.00	20.0	0.22	0.22	0.10	1.16	1.00	0.12	0.12	0.34
0.34	1.28	0.00	171.6	87.9	28.5								
5.01	1.46	0.60	30.0	20.00	20.0	0.22	0.22	0.10	1.16	1.00	0.12	0.12	0.34
0.34	1.29	0.00	171.6	87.9	28.5								
4.95	1.46	0.60	30.0	20.00	20.0	0.22	0.22	0.10	1.16	1.00	0.12	0.12	0.33
0.33	1.29	0.00	171.7	88.0	28.5								
4.89	1.46	0.59	30.0	20.00	20.0	0.21	0.21	0.10	1.16	1.00	0.12	0.12	0.33
0.33	1.29	0.00	171.7	88.0	28.5								
4.83	1.46	0.58	30.0	20.00	20.0	0.21	0.21	0.10	1.16	1.00	0.12	0.12	0.33
0.33	1.29	0.00	171.7	88.0	28.6								
4.77	1.46	0.58	30.0	20.00	20.0	0.21	0.21	0.10	1.16	1.00	0.12	0.12	0.33
0.33	1.29	0.00	171.7	88.1	28.6								
4.71	1.46	0.57	30.0	20.00	20.0	0.21	0.21	0.10	1.16	1.00	0.12	0.12	0.32
0.32	1.30	0.00	171.8	88.1	28.6								
4.65	1.46	0.56	30.0	20.00	20.0	0.20	0.20	0.10	1.16	1.00	0.12	0.12	0.32
0.32	1.30	0.00	171.8	88.1	28.6								
4.59	1.46	0.55	30.0	20.00	20.0	0.20	0.20	0.10	1.16	1.00	0.12	0.12	0.32
0.32	1.30	0.00	171.8	88.1	28.6								
4.53	1.46	0.55	30.0	20.00	20.0	0.20	0.20	0.10	1.16	1.00	0.12	0.12	0.32
0.32	1.30	0.00	171.9	88.2	28.6								
4.47	1.46	0.54	30.0	20.00	20.0	0.20	0.20	0.10	1.16	1.00	0.12	0.12	0.31
0.31	1.30	0.00	171.9	88.2	28.6								
4.41	1.46	0.53	30.0	20.00	20.0	0.19	0.19	0.10	1.16	1.00	0.12	0.12	0.31
0.31	1.31	0.00	171.9	88.2	28.6								
4.35	1.46	0.53	30.0	20.00	20.0	0.19	0.19	0.10	1.16	1.00	0.12	0.12	0.31
0.31	1.31	0.00	171.9	88.3	28.6								
4.29	1.46	0.52	30.0	20.00	20.0	0.19	0.19	0.10	1.16	1.00	0.12	0.12	0.31
0.31	1.31	0.00	172.0	88.3	28.6								
4.23	1.46	0.51	30.0	20.00	20.0	0.19	0.19	0.10	1.16	1.00	0.12	0.12	0.30
0.30	1.31	0.00	172.0	88.3	28.6								
4.17	1.46	0.50	30.0	20.00	20.0	0.18	0.18	0.10	1.16	1.00	0.12	0.12	0.30
0.30	1.31	0.00	172.0	88.3	28.6								
4.11	1.46	0.50	30.0	20.00	20.0	0.18	0.18	0.10	1.16	1.00	0.12	0.12	0.30
0.30	1.32	0.00	172.0	88.4	28.6								
4.05	1.46	0.49	30.0	20.00	20.0	0.18	0.18	0.10	1.16	1.00	0.12	0.12	0.29
0.29	1.32	0.00	172.1	88.4	28.6								
3.99	1.46	0.48	30.0	20.00	20.0	0.18	0.18	0.10	1.16	1.00	0.12	0.12	0.29

Ødetail

0.29	1.32	0.00	172.1	88.4	28.6								
3.93	1.46	0.48	30.0	20.00	20.0	0.17	0.17	0.10	1.16	1.00	0.12	0.12	0.29
0.29	1.32	0.00	172.1	88.5	28.6								
3.88	1.46	0.47	30.0	20.00	20.0	0.17	0.17	0.10	1.16	1.00	0.12	0.12	0.29
0.29	1.33	0.00	172.1	88.5	28.7								
3.82	1.46	0.46	30.0	20.00	20.0	0.17	0.17	0.10	1.16	1.00	0.12	0.12	0.28
0.28	1.33	0.00	172.2	88.5	28.7								
3.76	1.46	0.45	30.0	20.00	20.0	0.17	0.17	0.10	1.16	1.00	0.12	0.12	0.28
0.28	1.33	0.00	172.2	88.5	28.7								
3.70	1.46	0.45	30.0	20.00	20.0	0.16	0.16	0.10	1.16	1.00	0.12	0.12	0.28
0.28	1.33	0.00	172.2	88.6	28.7								
3.64	1.46	0.44	30.0	20.00	20.0	0.16	0.16	0.10	1.16	1.00	0.12	0.12	0.28
0.28	1.33	0.00	172.2	88.6	28.7								
3.58	1.46	0.43	30.0	20.00	20.0	0.16	0.16	0.10	1.16	1.00	0.12	0.12	0.27
0.27	1.34	0.00	172.3	88.6	28.7								
3.52	1.46	0.43	30.0	20.00	20.0	0.15	0.15	0.10	1.16	1.00	0.12	0.12	0.27
0.27	1.34	0.00	172.3	88.6	28.7								
3.46	1.46	0.42	30.0	20.00	20.0	0.15	0.15	0.10	1.16	1.00	0.12	0.12	0.27
0.27	1.34	0.00	172.3	88.7	28.7								
3.40	1.46	0.41	30.0	20.00	20.0	0.15	0.15	0.10	1.16	1.00	0.12	0.12	0.27
0.27	1.34	0.00	172.3	88.7	28.7								
3.34	1.46	0.40	30.0	20.00	20.0	0.15	0.15	0.10	1.16	1.00	0.12	0.12	0.26
0.26	1.34	0.00	172.4	88.7	28.7								
3.28	1.46	0.40	30.0	20.00	20.0	0.14	0.14	0.10	1.16	1.00	0.12	0.12	0.26
0.26	1.35	0.00	172.4	88.7	28.7								
3.22	1.46	0.39	30.0	20.00	20.0	0.14	0.14	0.10	1.16	1.00	0.12	0.12	0.26
0.26	1.35	0.00	172.4	88.8	28.7								
3.16	1.46	0.38	30.0	20.00	20.0	0.14	0.14	0.10	1.16	1.00	0.12	0.12	0.26
0.26	1.35	0.00	172.4	88.8	28.7								
3.10	1.46	0.38	30.0	20.00	20.0	0.14	0.14	0.10	1.16	1.00	0.12	0.12	0.25
0.25	1.35	0.00	172.4	88.8	28.7								
3.04	1.46	0.37	30.0	20.00	20.0	0.13	0.13	0.10	1.16	1.00	0.12	0.12	0.25
0.25	1.35	0.00	172.5	88.8	28.7								
2.98	1.46	0.36	30.0	20.00	20.0	0.13	0.13	0.10	1.16	1.00	0.12	0.12	0.25
0.25	1.36	0.00	172.5	88.9	28.7								
2.92	1.46	0.35	30.0	20.00	20.0	0.13	0.13	0.10	1.16	1.00	0.12	0.12	0.25
0.25	1.36	0.00	172.5	88.9	28.7								
2.86	1.46	0.35	30.0	20.00	20.0	0.13	0.13	0.10	1.16	1.00	0.12	0.12	0.24
0.24	1.36	0.00	172.5	88.9	28.7								
2.80	1.46	0.34	30.0	20.00	20.0	0.12	0.12	0.10	1.16	1.00	0.12	0.12	0.24
0.24	1.36	0.00	172.6	88.9	28.7								
2.74	1.46	0.33	30.0	20.00	20.0	0.12	0.12	0.10	1.16	1.00	0.12	0.12	0.24
0.24	1.36	0.00	172.6	89.0	28.8								
2.68	1.46	0.33	30.0	20.00	20.0	0.12	0.12	0.10	1.16	1.00	0.12	0.12	0.23
0.23	1.37	0.00	172.6	89.0	28.8								
2.62	1.46	0.32	30.0	20.00	20.0	0.12	0.12	0.10	1.16	1.00	0.12	0.12	0.23
0.23	1.37	0.00	172.6	89.0	28.8								
2.56	1.46	0.31	30.0	20.00	20.0	0.11	0.11	0.10	1.16	1.00	0.12	0.12	0.23
0.23	1.37	0.00	172.6	89.0	28.8								
2.50	1.46	0.30	30.0	20.00	20.0	0.11	0.11	0.10	1.16	1.00	0.12	0.12	0.23
0.23	1.37	0.00	172.7	89.0	28.8								
2.44	1.46	0.30	30.0	20.00	20.0	0.11	0.11	0.10	1.16	1.00	0.12	0.12	0.22
0.22	1.38	0.00	172.7	89.1	28.8								
2.38	1.46	0.29	30.0	20.00	20.0	0.11	0.11	0.10	1.16	1.00	0.12	0.12	0.22
0.22	1.38	0.00	172.7	89.1	28.8								
2.33	1.46	0.28	30.0	20.00	20.0	0.10	0.10	0.10	1.16	1.00	0.12	0.12	0.22
0.22	1.38	0.00	172.7	89.1	28.8								
2.27	1.46	0.28	30.0	20.00	20.0	0.10	0.10	0.10	1.16	1.00	0.12	0.12	0.22
0.22	1.38	0.00	172.7	89.1	28.8								
2.21	1.46	0.27	30.0	20.00	20.0	0.10	0.10	0.10	1.16	1.00	0.12	0.12	0.21
0.21	1.38	0.00	172.7	89.1	28.8								
2.15	1.46	0.26	30.0	20.00	20.0	0.10	0.10	0.10	1.16	1.00	0.12	0.12	0.21
0.21	1.39	0.00	172.8	89.2	28.8								
2.09	1.46	0.25	30.0	20.00	20.0	0.09	0.09	0.10	1.16	1.00	0.12	0.12	0.21
0.21	1.39	0.00	172.8	89.2	28.8								
2.03	1.46	0.25	30.0	20.00	20.0	0.09	0.09	0.10	1.16	1.00	0.12	0.12	0.21
0.21	1.39	0.00	172.8	89.2	28.8								

Ødetail

0.12 1.47 0.00 173.3 89.8 28.9

SETTLEMENT based on Ultimate Loading by Vesic Method (1977):

Ztip=29.75 Btip= 0.67 Cp= 0.030 Cs= 0.060
 Xpp=0.189-in Xps= 0.009-in Xtip= 0.197-in
 Cp & Cs are average value at bearing stratum from pile tip extend to 10 Btip

At loading: Qtip=85.0-kp Qtop= 173.3-kp Qside= 88.3-kp
 Xtip=0.197-in Xtop= 0.465-in Xshaft= 0.267-in

LOAD - TOTAL SETTLEMENT RELATION (from t-z, and q-w curves):

Based on Vesic Method (1977)

Xtop -in	Xshaft -in	Xtip -in	Qtip -kp	Qside -kp	Qtotal -kp
0.0007	0.0007	0.0000	0.1	0.5	0.7
0.0356	0.0331	0.0025	2.4	30.5	32.9
0.0498	0.0461	0.0037	3.6	42.0	45.6
0.0621	0.0572	0.0049	4.7	51.6	56.4
0.0730	0.0668	0.0062	5.9	59.6	65.4
0.0824	0.0750	0.0074	7.0	66.1	73.1
0.0908	0.0821	0.0086	8.2	71.3	79.5
0.0981	0.0882	0.0099	9.3	75.5	84.8
0.1046	0.0935	0.0111	10.5	78.9	89.3
0.1104	0.0981	0.0123	11.6	81.4	93.0
0.1156	0.1021	0.0136	12.7	83.4	96.2
0.1204	0.1056	0.0148	13.9	85.0	98.8
0.1248	0.1088	0.0160	15.0	86.1	101.0
0.1289	0.1116	0.0173	16.1	86.9	103.0
0.1327	0.1142	0.0185	17.2	87.4	104.6
0.1364	0.1166	0.0197	18.3	87.8	106.1
0.1399	0.1189	0.0210	19.4	88.0	107.4
0.1433	0.1211	0.0222	20.5	88.2	108.7
0.1466	0.1232	0.0234	21.5	88.3	109.8
0.1499	0.1252	0.0247	22.6	88.3	110.9
0.1531	0.1272	0.0259	23.7	88.3	111.9
0.1563	0.1291	0.0271	24.7	88.2	112.9
0.1594	0.1310	0.0284	25.7	88.2	113.9
0.1625	0.1329	0.0296	26.7	88.1	114.9
0.1655	0.1347	0.0308	27.8	88.0	115.8
0.1685	0.1364	0.0321	28.8	87.9	116.6
0.1714	0.1381	0.0333	29.7	87.7	117.5
0.1743	0.1398	0.0345	30.7	87.5	118.2
0.1771	0.1413	0.0358	31.7	87.2	118.9
0.1799	0.1428	0.0370	32.6	86.9	119.6
0.1825	0.1443	0.0382	33.6	86.6	120.1
0.1851	0.1456	0.0395	34.5	86.2	120.7
0.1876	0.1469	0.0407	35.4	85.7	121.1
0.1901	0.1481	0.0419	36.3	85.2	121.5
0.1925	0.1493	0.0432	37.2	84.7	121.9
0.1949	0.1505	0.0444	38.1	84.1	122.2
0.1973	0.1516	0.0456	38.9	83.6	122.5
0.1997	0.1528	0.0469	39.8	83.1	122.9
0.2021	0.1540	0.0481	40.6	82.8	123.4
0.2051	0.1557	0.0494	41.5	83.0	124.4
0.2078	0.1572	0.0506	42.3	82.9	125.1
0.2104	0.1586	0.0518	43.1	82.8	125.9
0.2131	0.1600	0.0531	43.8	82.7	126.6
0.2157	0.1614	0.0543	44.6	82.6	127.3
0.2183	0.1628	0.0555	45.4	82.6	128.0
0.2209	0.1641	0.0568	46.1	82.5	128.6
0.2234	0.1654	0.0580	46.9	82.4	129.3
0.2259	0.1667	0.0592	47.6	82.3	129.9
0.2284	0.1680	0.0605	48.3	82.3	130.6
0.2309	0.1692	0.0617	49.0	82.2	131.2
0.2334	0.1705	0.0629	49.7	82.1	131.8
0.2358	0.1717	0.0642	50.4	82.0	132.4

Ødetail

0.2382	0.1728	0.0654	51.0	81.9	133.0
0.2406	0.1740	0.0666	51.7	81.9	133.5
0.2430	0.1751	0.0679	52.3	81.8	134.1
0.2453	0.1762	0.0691	53.0	81.7	134.6
0.2476	0.1773	0.0703	53.6	81.6	135.2
0.2499	0.1784	0.0716	54.2	81.5	135.7
0.2522	0.1794	0.0728	54.8	81.4	136.2
0.2545	0.1805	0.0740	55.4	81.4	136.7
0.2567	0.1815	0.0753	55.9	81.3	137.2
0.2589	0.1825	0.0765	56.5	81.2	137.7
0.2611	0.1834	0.0777	57.1	81.1	138.2
0.2633	0.1844	0.0790	57.6	81.0	138.6
0.2655	0.1853	0.0802	58.1	81.0	139.1
0.2677	0.1862	0.0814	58.7	80.9	139.5
0.2698	0.1871	0.0827	59.2	80.8	140.0
0.2719	0.1880	0.0839	59.7	80.7	140.4
0.2740	0.1889	0.0851	60.2	80.6	140.8
0.2761	0.1897	0.0864	60.7	80.6	141.3
0.2782	0.1906	0.0876	61.2	80.5	141.7
0.2802	0.1914	0.0888	61.6	80.4	142.1
0.2823	0.1922	0.0901	62.1	80.3	142.4
0.2843	0.1930	0.0913	62.6	80.3	142.8
0.2863	0.1938	0.0925	63.0	80.2	143.2
0.2883	0.1945	0.0938	63.5	80.1	143.6
0.2903	0.1953	0.0950	63.9	80.0	143.9
0.2922	0.1960	0.0962	64.3	79.9	144.3
0.2942	0.1967	0.0975	64.7	79.9	144.6
0.2961	0.1974	0.0987	65.2	79.8	144.9
0.2981	0.1981	0.0999	65.6	79.7	145.3
0.3000	0.1988	0.1012	66.0	79.6	145.6
0.3019	0.1995	0.1024	66.4	79.6	145.9
0.3038	0.2002	0.1036	66.8	79.5	146.2
0.3057	0.2008	0.1049	67.1	79.4	146.5
0.3076	0.2015	0.1061	67.5	79.3	146.9
0.3094	0.2021	0.1073	67.9	79.3	147.2
0.3113	0.2027	0.1086	68.3	79.2	147.4
0.3131	0.2033	0.1098	68.6	79.1	147.7
0.3150	0.2039	0.1110	69.0	79.0	148.0
0.3168	0.2045	0.1123	69.3	79.0	148.3
0.3186	0.2051	0.1135	69.7	78.9	148.6
0.3205	0.2057	0.1147	70.0	78.8	148.8
0.3223	0.2063	0.1160	70.4	78.7	149.1
0.3329	0.2095	0.1234	72.3	78.3	150.6
0.3669	0.2188	0.1481	78.0	76.8	154.8
0.3985	0.2258	0.1727	82.4	75.3	157.7
0.4266	0.2292	0.1974	85.0	73.8	158.8
0.4492	0.2271	0.2221	84.6	72.3	156.9
0.4653	0.2185	0.2468	80.8	70.8	151.6

At Qwork= 150.00-kp Settlement= 0.32861-in
 At Qwork= 150.00-kp Secant Stiffness Kqx= 456.46-kp/-in
 At Xallow= 1.00-in Q= 99999.00-kp

Note: If the program cannot find a result or the result exceeds the upper limit. The result will be displayed as 99999.

SUMMARY:

Total Ultimate Capacity (Down)= 173.279-kp Total Ultimate Capacity (Up)= 89.763-kp
 Total Allowable Capacity (Down)= 101.355-kp Total Allowable Capacity (Up)= 45.616-kp

Weight above Ground= 0.01 Total Pile Weight= 1.47-kp *Soil Weight is not included
 Side Resistance (Down)= 88.293-kp Side Resistance (Up)= 88.294-kp
 Tip Resistance (Down)= 84.986-kp Tip Resistance (Up)= 0.000-kp
 Negative Friction, Qneg= 0.000-kp, which has been subtracted from Total Ultimate Capacity (Down)
 Negative friction does not affect Total Uplift Ultimate Capacity (Up)

N/G! Qallow < Q * Vertical Load, Q= 150.0 -kp

Ødetail

FACTOR OF SAFETY:

FSSide FStip FSup FSweight

1.5 2.0 2.0 1.0

* FStorsion = FSSide

Notes:

* Settlement in the program is Elastic Settlement only. Consolidation Settlement is not calculated!

Length - Pile length, distance from pile top to tip (not from ground surface)

Width or D - Width of pile shaft (pile diameter)

Ds and Dl - Short Side and Long Side of Footing

Area - Section area of pile shaft or tip area of pile

Sv - Vertical stress in soils (It may be limited based on critical depth, Z_lim or Z/D

qult - Ultimate tip resistance (pressure)

Qtip_dw - Ultimate downward tip resistance (Force or Capacity)

Qtip_up - Ultimate uplift tip resistance for belled pile or uplift plate (Force or Capacity)

Torsion - Ultimate torsion resistance for single pile (Capacity)

dz - Small Segment of Depth for Calculation

Zs - Soil Depth, Depth from ground surface

Zp - Pile Depth, Depth from pile top

Prem - Primer of pile shaft

Phi - Soil internal friction angle (between soils)

Kf - Friction factor to convert Phi to Delta

Delta - Ski friction between soil and pile (function of Phi. It is different from Phi)

f_dw - Downward Resistance between soil and pile from Delta

f_up - Uplift Resistance between soil and pile from Delta

C - Soil cohesion (between soils)

Ca - Adhesion between soil and pile (function of C. It is different from C) Ca=KaKcC

Ka - Adhesion ratio, C/Ca

Kc - Adhesion factor defended by users

Ca_dw - Downward adhesion between pile and soil

Ca_up - Uplift adhesion between pile and soil

Sf_dw - Downward side resistance (sum of friction and adhesion, f_dw + Ca_dw)

Sf_up - Uplift side resistance (sum of friction and adhesion, f_up + Ca_up)

Torsion side resistance = (Sf_dw+Sf_up)/2 * pile diameter/2

Weight - Weight of Pile shaft

Qneg - negative friction Resistance

Qside - Ultimate side resistance (Qside_dw or Qside_up)

Qtip - Ultimate tip resistance (Qtip_dw or Qtip_up for uplift plate)

Q_dw - Ultimate downward capacity (Qtip + Qside_dw)

Q_up - Ultimate uplift capacity (Weight + Qside_up)

E - Elastic modules

Xs - Settlement due to axial deformation of pile shaft

Xpp - Settlement due to point load from pile tip

Xps - Settlement due to load from pile shaft

Xtop - Total settlement, Xs + Xpp + Xps

Xtip - Tip settlement, Xpp + Xps

Xshaft - Shaft deformation, Xs

Xallow - Allowable settlement specified by users

Qwork - Vertical working load applied to pile

Qallow - Vertical allowable load, Qult/F.S.

SOIL STRESS, SIDE RESISTANCE, & AXIAL FORCE vs DEPTH Based on Ultimate Load Condition

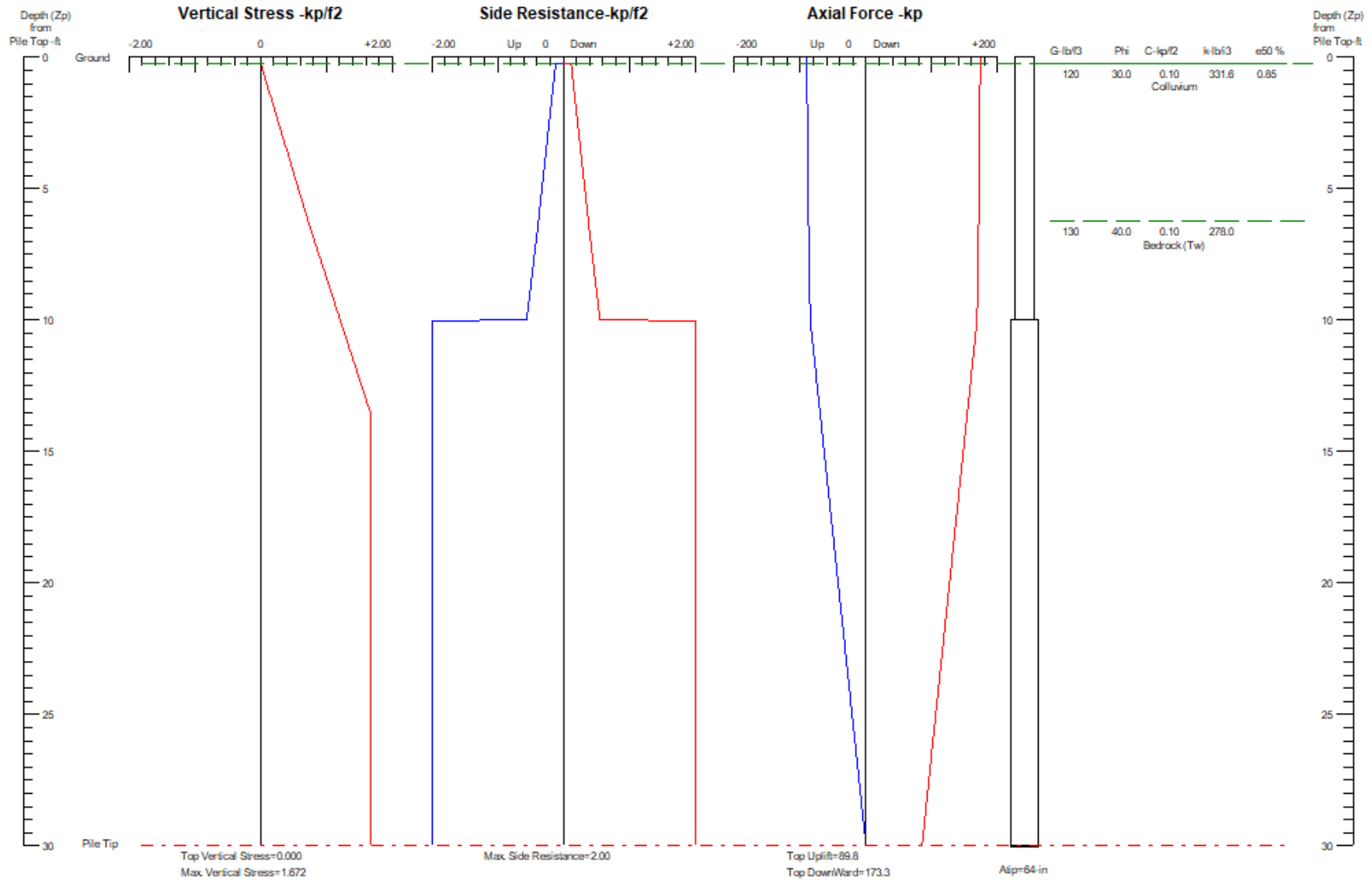

**CivilTech
Software**

**Lot 44
Foundations P1-P8**

Figure 1

Ødetail

Depth vs. Soil Stress, Side Resistance, and Pile Axial Force:

Zp -ft	Sv -kp/f2	Sf_dw -kp/f2	Sf_up -kp/f2	Q_dw -kp	Q_up -kp
0.0	0.00	0.00	0.00	173.3	89.8
0.3	0.00	0.00	0.00	173.3	89.8
0.3	0.00	0.12	0.12	173.3	89.8
0.3	0.01	0.12	0.12	173.3	89.7
0.4	0.02	0.12	0.12	173.3	89.7
0.4	0.03	0.13	0.13	173.2	89.7
0.5	0.03	0.13	0.13	173.2	89.7
0.5	0.04	0.13	0.13	173.2	89.7
0.6	0.05	0.13	0.13	173.2	89.7
0.7	0.05	0.14	0.14	173.2	89.7
0.7	0.06	0.14	0.14	173.2	89.6
0.8	0.07	0.14	0.14	173.2	89.6
0.8	0.08	0.14	0.14	173.2	89.6
0.9	0.08	0.15	0.15	173.2	89.6
1.0	0.09	0.15	0.15	173.1	89.6
1.0	0.10	0.15	0.15	173.1	89.6
1.1	0.10	0.15	0.15	173.1	89.6
1.1	0.11	0.16	0.16	173.1	89.5
1.2	0.12	0.16	0.16	173.1	89.5
1.3	0.13	0.16	0.16	173.1	89.5
1.3	0.13	0.16	0.16	173.1	89.5
1.4	0.14	0.17	0.17	173.0	89.5
1.4	0.15	0.17	0.17	173.0	89.5
1.5	0.15	0.17	0.17	173.0	89.4
1.6	0.16	0.18	0.18	173.0	89.4
1.6	0.17	0.18	0.18	173.0	89.4
1.7	0.18	0.18	0.18	173.0	89.4
1.7	0.18	0.18	0.18	173.0	89.4
1.8	0.19	0.19	0.19	172.9	89.4
1.9	0.20	0.19	0.19	172.9	89.3
1.9	0.20	0.19	0.19	172.9	89.3
2.0	0.21	0.19	0.19	172.9	89.3
2.0	0.22	0.20	0.20	172.9	89.3
2.1	0.23	0.20	0.20	172.9	89.3
2.2	0.23	0.20	0.20	172.8	89.2
2.2	0.24	0.20	0.20	172.8	89.2
2.3	0.25	0.21	0.21	172.8	89.2
2.3	0.25	0.21	0.21	172.8	89.2
2.4	0.26	0.21	0.21	172.8	89.2
2.5	0.27	0.21	0.21	172.7	89.1
2.5	0.28	0.22	0.22	172.7	89.1
2.6	0.28	0.22	0.22	172.7	89.1
2.6	0.29	0.22	0.22	172.7	89.1
2.7	0.30	0.22	0.22	172.7	89.1
2.8	0.30	0.23	0.23	172.7	89.0
2.8	0.31	0.23	0.23	172.6	89.0
2.9	0.32	0.23	0.23	172.6	89.0
2.9	0.33	0.23	0.23	172.6	89.0
3.0	0.33	0.24	0.24	172.6	89.0
3.1	0.34	0.24	0.24	172.6	88.9
3.1	0.35	0.24	0.24	172.5	88.9
3.2	0.35	0.25	0.25	172.5	88.9
3.2	0.36	0.25	0.25	172.5	88.9
3.3	0.37	0.25	0.25	172.5	88.8
3.4	0.38	0.25	0.25	172.4	88.8
3.4	0.38	0.26	0.26	172.4	88.8
3.5	0.39	0.26	0.26	172.4	88.8
3.5	0.40	0.26	0.26	172.4	88.7

Ødetail

3.6	0.40	0.26	0.26	172.4	88.7
3.6	0.41	0.27	0.27	172.3	88.7
3.7	0.42	0.27	0.27	172.3	88.7
3.8	0.43	0.27	0.27	172.3	88.6
3.8	0.43	0.27	0.27	172.3	88.6
3.9	0.44	0.28	0.28	172.2	88.6
3.9	0.45	0.28	0.28	172.2	88.6
4.0	0.45	0.28	0.28	172.2	88.5
4.1	0.46	0.28	0.28	172.2	88.5
4.1	0.47	0.29	0.29	172.1	88.5
4.2	0.48	0.29	0.29	172.1	88.5
4.2	0.48	0.29	0.29	172.1	88.4
4.3	0.49	0.29	0.29	172.1	88.4
4.4	0.50	0.30	0.30	172.0	88.4
4.4	0.50	0.30	0.30	172.0	88.3
4.5	0.51	0.30	0.30	172.0	88.3
4.5	0.52	0.31	0.31	172.0	88.3
4.6	0.53	0.31	0.31	171.9	88.3
4.7	0.53	0.31	0.31	171.9	88.2
4.7	0.54	0.31	0.31	171.9	88.2
4.8	0.55	0.32	0.32	171.9	88.2
4.8	0.55	0.32	0.32	171.8	88.1
4.9	0.56	0.32	0.32	171.8	88.1
5.0	0.57	0.32	0.32	171.8	88.1
5.0	0.58	0.33	0.33	171.7	88.1
5.1	0.58	0.33	0.33	171.7	88.0
5.1	0.59	0.33	0.33	171.7	88.0
5.2	0.60	0.33	0.33	171.7	88.0
5.3	0.60	0.34	0.34	171.6	87.9
5.3	0.61	0.34	0.34	171.6	87.9
5.4	0.62	0.34	0.34	171.6	87.9
5.4	0.63	0.34	0.34	171.5	87.8
5.5	0.63	0.35	0.35	171.5	87.8
5.6	0.64	0.35	0.35	171.5	87.8
5.6	0.65	0.35	0.35	171.5	87.7
5.7	0.65	0.35	0.35	171.4	87.7
5.7	0.66	0.36	0.36	171.4	87.7
5.8	0.67	0.36	0.36	171.4	87.6
5.9	0.68	0.36	0.36	171.3	87.6
5.9	0.68	0.37	0.37	171.3	87.6
6.0	0.69	0.37	0.37	171.3	87.5
6.0	0.70	0.37	0.37	171.2	87.5
6.1	0.70	0.37	0.37	171.2	87.5
6.2	0.71	0.38	0.38	171.2	87.4
6.2	0.72	0.38	0.38	171.1	87.4
6.3	0.73	0.38	0.38	171.1	87.4
6.3	0.73	0.38	0.38	171.1	87.3
6.4	0.74	0.39	0.39	171.0	87.3
6.5	0.75	0.39	0.39	171.0	87.3
6.5	0.76	0.39	0.39	171.0	87.2
6.6	0.76	0.39	0.39	170.9	87.2
6.6	0.77	0.40	0.40	170.9	87.2
6.7	0.78	0.40	0.40	170.9	87.1
6.7	0.79	0.40	0.40	170.8	87.1
6.8	0.80	0.41	0.41	170.8	87.0
6.9	0.80	0.41	0.41	170.8	87.0
6.9	0.81	0.41	0.41	170.7	87.0
7.0	0.82	0.41	0.41	170.7	86.9
7.0	0.83	0.42	0.42	170.7	86.9
7.1	0.83	0.42	0.42	170.6	86.9
7.2	0.84	0.42	0.42	170.6	86.8
7.2	0.85	0.43	0.43	170.5	86.8
7.3	0.86	0.43	0.43	170.5	86.7
7.3	0.87	0.43	0.43	170.5	86.7
7.4	0.87	0.43	0.43	170.4	86.7
7.5	0.88	0.44	0.44	170.4	86.6
7.5	0.89	0.44	0.44	170.4	86.6

Ødetail

7.6	0.90	0.44	0.44	170.3	86.5
7.6	0.90	0.45	0.45	170.3	86.5
7.7	0.91	0.45	0.45	170.2	86.5
7.8	0.92	0.45	0.45	170.2	86.4
7.8	0.93	0.45	0.45	170.2	86.4
7.9	0.94	0.46	0.46	170.1	86.3
7.9	0.94	0.46	0.46	170.1	86.3
8.0	0.95	0.46	0.46	170.0	86.2
8.1	0.96	0.47	0.47	170.0	86.2
8.1	0.97	0.47	0.47	170.0	86.2
8.2	0.97	0.47	0.47	169.9	86.1
8.2	0.98	0.47	0.47	169.9	86.1
8.3	0.99	0.48	0.48	169.8	86.0
8.4	1.00	0.48	0.48	169.8	86.0
8.4	1.01	0.48	0.48	169.8	85.9
8.5	1.01	0.49	0.49	169.7	85.9
8.5	1.02	0.49	0.49	169.7	85.9
8.6	1.03	0.49	0.49	169.6	85.8
8.7	1.04	0.49	0.49	169.6	85.8
8.7	1.04	0.50	0.50	169.5	85.7
8.8	1.05	0.50	0.50	169.5	85.7
8.8	1.06	0.50	0.50	169.5	85.6
8.9	1.07	0.50	0.50	169.4	85.6
9.0	1.07	0.51	0.51	169.4	85.5
9.0	1.08	0.51	0.51	169.3	85.5
9.1	1.09	0.51	0.51	169.3	85.4
9.1	1.10	0.52	0.52	169.2	85.4
9.2	1.11	0.52	0.52	169.2	85.4
9.3	1.11	0.52	0.52	169.1	85.3
9.3	1.12	0.52	0.52	169.1	85.3
9.4	1.13	0.53	0.53	169.1	85.2
9.4	1.14	0.53	0.53	169.0	85.2
9.5	1.14	0.53	0.53	169.0	85.1
9.6	1.15	0.54	0.54	168.9	85.1
9.6	1.16	0.54	0.54	168.9	85.0
9.7	1.17	0.54	0.54	168.8	85.0
9.7	1.18	0.54	0.54	168.8	84.9
9.8	1.18	0.55	0.55	168.7	84.9
9.8	1.19	0.55	0.55	168.7	84.8
9.9	1.20	0.55	0.55	168.6	84.8
10.0	1.21	0.56	0.56	168.6	84.7
10.0	1.21	2.00	2.00	168.5	84.7
10.1	1.22	2.00	2.00	168.3	84.4
10.1	1.23	2.00	2.00	168.0	84.2
10.2	1.24	2.00	2.00	167.8	83.9
10.3	1.25	2.00	2.00	167.5	83.7
10.3	1.25	2.00	2.00	167.3	83.4
10.4	1.26	2.00	2.00	167.0	83.2
10.4	1.27	2.00	2.00	166.8	82.9
10.5	1.28	2.00	2.00	166.5	82.6
10.6	1.28	2.00	2.00	166.3	82.4
10.6	1.29	2.00	2.00	166.0	82.1
10.7	1.30	2.00	2.00	165.8	81.9
10.7	1.31	2.00	2.00	165.5	81.6
10.8	1.32	2.00	2.00	165.3	81.4
10.9	1.32	2.00	2.00	165.0	81.1
10.9	1.33	2.00	2.00	164.8	80.9
11.0	1.34	2.00	2.00	164.5	80.6
11.0	1.35	2.00	2.00	164.3	80.4
11.1	1.35	2.00	2.00	164.0	80.1
11.2	1.36	2.00	2.00	163.8	79.9
11.2	1.37	2.00	2.00	163.5	79.6
11.3	1.38	2.00	2.00	163.3	79.4
11.3	1.38	2.00	2.00	163.0	79.1
11.4	1.39	2.00	2.00	162.8	78.9
11.5	1.40	2.00	2.00	162.6	78.6
11.5	1.41	2.00	2.00	162.3	78.4

Ødetail

11.6	1.42	2.00	2.00	162.1	78.1
11.6	1.42	2.00	2.00	161.8	77.8
11.7	1.43	2.00	2.00	161.6	77.6
11.8	1.44	2.00	2.00	161.3	77.3
11.8	1.45	2.00	2.00	161.1	77.1
11.9	1.45	2.00	2.00	160.8	76.8
11.9	1.46	2.00	2.00	160.6	76.6
12.0	1.47	2.00	2.00	160.3	76.3
12.1	1.48	2.00	2.00	160.1	76.1
12.1	1.49	2.00	2.00	159.8	75.8
12.2	1.49	2.00	2.00	159.6	75.6
12.2	1.50	2.00	2.00	159.3	75.3
12.3	1.51	2.00	2.00	159.1	75.1
12.4	1.52	2.00	2.00	158.8	74.8
12.4	1.52	2.00	2.00	158.6	74.6
12.5	1.53	2.00	2.00	158.3	74.3
12.5	1.54	2.00	2.00	158.1	74.1
12.6	1.55	2.00	2.00	157.8	73.8
12.7	1.56	2.00	2.00	157.6	73.5
12.7	1.56	2.00	2.00	157.3	73.3
12.8	1.57	2.00	2.00	157.1	73.0
12.8	1.58	2.00	2.00	156.8	72.8
12.9	1.59	2.00	2.00	156.6	72.5
12.9	1.59	2.00	2.00	156.3	72.3
13.0	1.60	2.00	2.00	156.1	72.0
13.1	1.61	2.00	2.00	155.8	71.8
13.1	1.62	2.00	2.00	155.6	71.5
13.2	1.63	2.00	2.00	155.3	71.3
13.2	1.63	2.00	2.00	155.1	71.0
13.3	1.64	2.00	2.00	154.8	70.8
13.4	1.65	2.00	2.00	154.6	70.5
13.4	1.66	2.00	2.00	154.3	70.3
13.5	1.66	2.00	2.00	154.1	70.0
13.5	1.67	2.00	2.00	153.8	69.8
13.6	1.67	2.00	2.00	153.6	69.5
13.7	1.67	2.00	2.00	153.3	69.3
13.7	1.67	2.00	2.00	153.1	69.0
13.8	1.67	2.00	2.00	152.8	68.7
13.8	1.67	2.00	2.00	152.6	68.5
13.9	1.67	2.00	2.00	152.3	68.2
14.0	1.67	2.00	2.00	152.1	68.0
14.0	1.67	2.00	2.00	151.8	67.7
14.1	1.67	2.00	2.00	151.6	67.5
14.1	1.67	2.00	2.00	151.3	67.2
14.2	1.67	2.00	2.00	151.1	67.0
14.3	1.67	2.00	2.00	150.8	66.7
14.3	1.67	2.00	2.00	150.6	66.5
14.4	1.67	2.00	2.00	150.3	66.2
14.4	1.67	2.00	2.00	150.1	66.0
14.5	1.67	2.00	2.00	149.8	65.7
14.6	1.67	2.00	2.00	149.6	65.5
14.6	1.67	2.00	2.00	149.3	65.2
14.7	1.67	2.00	2.00	149.1	65.0
14.7	1.67	2.00	2.00	148.8	64.7
14.8	1.67	2.00	2.00	148.6	64.5
14.9	1.67	2.00	2.00	148.3	64.2
14.9	1.67	2.00	2.00	148.1	63.9
15.0	1.67	2.00	2.00	147.8	63.7
15.0	1.67	2.00	2.00	147.6	63.4
15.1	1.67	2.00	2.00	147.3	63.2
15.2	1.67	2.00	2.00	147.1	62.9
15.2	1.67	2.00	2.00	146.8	62.7
15.3	1.67	2.00	2.00	146.6	62.4
15.3	1.67	2.00	2.00	146.3	62.2
15.4	1.67	2.00	2.00	146.1	61.9
15.5	1.67	2.00	2.00	145.8	61.7
15.5	1.67	2.00	2.00	145.6	61.4

Ødetail

15.6	1.67	2.00	2.00	145.3	61.2
15.6	1.67	2.00	2.00	145.1	60.9
15.7	1.67	2.00	2.00	144.8	60.7
15.8	1.67	2.00	2.00	144.6	60.4
15.8	1.67	2.00	2.00	144.3	60.2
15.9	1.67	2.00	2.00	144.1	59.9
15.9	1.67	2.00	2.00	143.8	59.6
16.0	1.67	2.00	2.00	143.6	59.4
16.0	1.67	2.00	2.00	143.3	59.1
16.1	1.67	2.00	2.00	143.1	58.9
16.2	1.67	2.00	2.00	142.8	58.6
16.2	1.67	2.00	2.00	142.6	58.4
16.3	1.67	2.00	2.00	142.3	58.1
16.3	1.67	2.00	2.00	142.1	57.9
16.4	1.67	2.00	2.00	141.9	57.6
16.5	1.67	2.00	2.00	141.6	57.4
16.5	1.67	2.00	2.00	141.4	57.1
16.6	1.67	2.00	2.00	141.1	56.9
16.6	1.67	2.00	2.00	140.9	56.6
16.7	1.67	2.00	2.00	140.6	56.4
16.8	1.67	2.00	2.00	140.4	56.1
16.8	1.67	2.00	2.00	140.1	55.9
16.9	1.67	2.00	2.00	139.9	55.6
16.9	1.67	2.00	2.00	139.6	55.4
17.0	1.67	2.00	2.00	139.4	55.1
17.1	1.67	2.00	2.00	139.1	54.8
17.1	1.67	2.00	2.00	138.9	54.6
17.2	1.67	2.00	2.00	138.6	54.3
17.2	1.67	2.00	2.00	138.4	54.1
17.3	1.67	2.00	2.00	138.1	53.8
17.4	1.67	2.00	2.00	137.9	53.6
17.4	1.67	2.00	2.00	137.6	53.3
17.5	1.67	2.00	2.00	137.4	53.1
17.5	1.67	2.00	2.00	137.1	52.8
17.6	1.67	2.00	2.00	136.9	52.6
17.7	1.67	2.00	2.00	136.6	52.3
17.7	1.67	2.00	2.00	136.4	52.1
17.8	1.67	2.00	2.00	136.1	51.8
17.8	1.67	2.00	2.00	135.9	51.6
17.9	1.67	2.00	2.00	135.6	51.3
18.0	1.67	2.00	2.00	135.4	51.1
18.0	1.67	2.00	2.00	135.1	50.8
18.1	1.67	2.00	2.00	134.9	50.5
18.1	1.67	2.00	2.00	134.6	50.3
18.2	1.67	2.00	2.00	134.4	50.0
18.3	1.67	2.00	2.00	134.1	49.8
18.3	1.67	2.00	2.00	133.9	49.5
18.4	1.67	2.00	2.00	133.6	49.3
18.4	1.67	2.00	2.00	133.4	49.0
18.5	1.67	2.00	2.00	133.1	48.8
18.6	1.67	2.00	2.00	132.9	48.5
18.6	1.67	2.00	2.00	132.6	48.3
18.7	1.67	2.00	2.00	132.4	48.0
18.7	1.67	2.00	2.00	132.1	47.8
18.8	1.67	2.00	2.00	131.9	47.5
18.9	1.67	2.00	2.00	131.6	47.3
18.9	1.67	2.00	2.00	131.4	47.0
19.0	1.67	2.00	2.00	131.1	46.8
19.0	1.67	2.00	2.00	130.9	46.5
19.1	1.67	2.00	2.00	130.6	46.3
19.1	1.67	2.00	2.00	130.4	46.0
19.2	1.67	2.00	2.00	130.1	45.7
19.3	1.67	2.00	2.00	129.9	45.5
19.3	1.67	2.00	2.00	129.6	45.2
19.4	1.67	2.00	2.00	129.4	45.0
19.4	1.67	2.00	2.00	129.1	44.7
19.5	1.67	2.00	2.00	128.9	44.5

Ødetail

19.6	1.67	2.00	2.00	128.6	44.2
19.6	1.67	2.00	2.00	128.4	44.0
19.7	1.67	2.00	2.00	128.1	43.7
19.7	1.67	2.00	2.00	127.9	43.5
19.8	1.67	2.00	2.00	127.6	43.2
19.9	1.67	2.00	2.00	127.4	43.0
19.9	1.67	2.00	2.00	127.1	42.7
20.0	1.67	2.00	2.00	126.9	42.5
20.0	1.67	2.00	2.00	126.6	42.2
20.1	1.67	2.00	2.00	126.4	42.0
20.2	1.67	2.00	2.00	126.1	41.7
20.2	1.67	2.00	2.00	125.9	41.5
20.3	1.67	2.00	2.00	125.6	41.2
20.3	1.67	2.00	2.00	125.4	40.9
20.4	1.67	2.00	2.00	125.1	40.7
20.5	1.67	2.00	2.00	124.9	40.4
20.5	1.67	2.00	2.00	124.6	40.2
20.6	1.67	2.00	2.00	124.4	39.9
20.6	1.67	2.00	2.00	124.1	39.7
20.7	1.67	2.00	2.00	123.9	39.4
20.8	1.67	2.00	2.00	123.6	39.2
20.8	1.67	2.00	2.00	123.4	38.9
20.9	1.67	2.00	2.00	123.1	38.7
20.9	1.67	2.00	2.00	122.9	38.4
21.0	1.67	2.00	2.00	122.6	38.2
21.1	1.67	2.00	2.00	122.4	37.9
21.1	1.67	2.00	2.00	122.1	37.7
21.2	1.67	2.00	2.00	121.9	37.4
21.2	1.67	2.00	2.00	121.6	37.2
21.3	1.67	2.00	2.00	121.4	36.9
21.4	1.67	2.00	2.00	121.1	36.6
21.4	1.67	2.00	2.00	120.9	36.4
21.5	1.67	2.00	2.00	120.7	36.1
21.5	1.67	2.00	2.00	120.4	35.9
21.6	1.67	2.00	2.00	120.2	35.6
21.7	1.67	2.00	2.00	119.9	35.4
21.7	1.67	2.00	2.00	119.7	35.1
21.8	1.67	2.00	2.00	119.4	34.9
21.8	1.67	2.00	2.00	119.2	34.6
21.9	1.67	2.00	2.00	118.9	34.4
22.0	1.67	2.00	2.00	118.7	34.1
22.0	1.67	2.00	2.00	118.4	33.9
22.1	1.67	2.00	2.00	118.2	33.6
22.1	1.67	2.00	2.00	117.9	33.4
22.2	1.67	2.00	2.00	117.7	33.1
22.2	1.67	2.00	2.00	117.4	32.9
22.3	1.67	2.00	2.00	117.2	32.6
22.4	1.67	2.00	2.00	116.9	32.4
22.4	1.67	2.00	2.00	116.7	32.1
22.5	1.67	2.00	2.00	116.4	31.8
22.5	1.67	2.00	2.00	116.2	31.6
22.6	1.67	2.00	2.00	115.9	31.3
22.7	1.67	2.00	2.00	115.7	31.1
22.7	1.67	2.00	2.00	115.4	30.8
22.8	1.67	2.00	2.00	115.2	30.6
22.8	1.67	2.00	2.00	114.9	30.3
22.9	1.67	2.00	2.00	114.7	30.1
23.0	1.67	2.00	2.00	114.4	29.8
23.0	1.67	2.00	2.00	114.2	29.6
23.1	1.67	2.00	2.00	113.9	29.3
23.1	1.67	2.00	2.00	113.7	29.1
23.2	1.67	2.00	2.00	113.4	28.8
23.3	1.67	2.00	2.00	113.2	28.6
23.3	1.67	2.00	2.00	112.9	28.3
23.4	1.67	2.00	2.00	112.7	28.1
23.4	1.67	2.00	2.00	112.4	27.8
23.5	1.67	2.00	2.00	112.2	27.5

Ødetail

23.6	1.67	2.00	2.00	111.9	27.3
23.6	1.67	2.00	2.00	111.7	27.0
23.7	1.67	2.00	2.00	111.4	26.8
23.7	1.67	2.00	2.00	111.2	26.5
23.8	1.67	2.00	2.00	110.9	26.3
23.9	1.67	2.00	2.00	110.7	26.0
23.9	1.67	2.00	2.00	110.4	25.8
24.0	1.67	2.00	2.00	110.2	25.5
24.0	1.67	2.00	2.00	109.9	25.3
24.1	1.67	2.00	2.00	109.7	25.0
24.2	1.67	2.00	2.00	109.4	24.8
24.2	1.67	2.00	2.00	109.2	24.5
24.3	1.67	2.00	2.00	108.9	24.3
24.3	1.67	2.00	2.00	108.7	24.0
24.4	1.67	2.00	2.00	108.4	23.8
24.5	1.67	2.00	2.00	108.2	23.5
24.5	1.67	2.00	2.00	107.9	23.3
24.6	1.67	2.00	2.00	107.7	23.0
24.6	1.67	2.00	2.00	107.4	22.7
24.7	1.67	2.00	2.00	107.2	22.5
24.8	1.67	2.00	2.00	106.9	22.2
24.8	1.67	2.00	2.00	106.7	22.0
24.9	1.67	2.00	2.00	106.4	21.7
24.9	1.67	2.00	2.00	106.2	21.5
25.0	1.67	2.00	2.00	105.9	21.2
25.1	1.67	2.00	2.00	105.7	21.0
25.1	1.67	2.00	2.00	105.4	20.7
25.2	1.67	2.00	2.00	105.2	20.5
25.2	1.67	2.00	2.00	104.9	20.2
25.3	1.67	2.00	2.00	104.7	20.0
25.3	1.67	2.00	2.00	104.4	19.7
25.4	1.67	2.00	2.00	104.2	19.5
25.5	1.67	2.00	2.00	103.9	19.2
25.5	1.67	2.00	2.00	103.7	19.0
25.6	1.67	2.00	2.00	103.4	18.7
25.6	1.67	2.00	2.00	103.2	18.5
25.7	1.67	2.00	2.00	102.9	18.2
25.8	1.67	2.00	2.00	102.7	17.9
25.8	1.67	2.00	2.00	102.4	17.7
25.9	1.67	2.00	2.00	102.2	17.4
25.9	1.67	2.00	2.00	101.9	17.2
26.0	1.67	2.00	2.00	101.7	16.9
26.1	1.67	2.00	2.00	101.4	16.7
26.1	1.67	2.00	2.00	101.2	16.4
26.2	1.67	2.00	2.00	100.9	16.2
26.2	1.67	2.00	2.00	100.7	15.9
26.3	1.67	2.00	2.00	100.4	15.7
26.4	1.67	2.00	2.00	100.2	15.4
26.4	1.67	2.00	2.00	100.0	15.2
26.5	1.67	2.00	2.00	99.7	14.9
26.5	1.67	2.00	2.00	99.5	14.7
26.6	1.67	2.00	2.00	99.2	14.4
26.7	1.67	2.00	2.00	99.0	14.2
26.7	1.67	2.00	2.00	98.7	13.9
26.8	1.67	2.00	2.00	98.5	13.6
26.8	1.67	2.00	2.00	98.2	13.4
26.9	1.67	2.00	2.00	98.0	13.1
27.0	1.67	2.00	2.00	97.7	12.9
27.0	1.67	2.00	2.00	97.5	12.6
27.1	1.67	2.00	2.00	97.2	12.4
27.1	1.67	2.00	2.00	97.0	12.1
27.2	1.67	2.00	2.00	96.7	11.9
27.3	1.67	2.00	2.00	96.5	11.6
27.3	1.67	2.00	2.00	96.2	11.4
27.4	1.67	2.00	2.00	96.0	11.1
27.4	1.67	2.00	2.00	95.7	10.9
27.5	1.67	2.00	2.00	95.5	10.6

Ødetail

27.6	1.67	2.00	2.00	95.2	10.4
27.6	1.67	2.00	2.00	95.0	10.1
27.7	1.67	2.00	2.00	94.7	9.9
27.7	1.67	2.00	2.00	94.5	9.6
27.8	1.67	2.00	2.00	94.2	9.4
27.9	1.67	2.00	2.00	94.0	9.1
27.9	1.67	2.00	2.00	93.7	8.8
28.0	1.67	2.00	2.00	93.5	8.6
28.0	1.67	2.00	2.00	93.2	8.3
28.1	1.67	2.00	2.00	93.0	8.1
28.2	1.67	2.00	2.00	92.7	7.8
28.2	1.67	2.00	2.00	92.5	7.6
28.3	1.67	2.00	2.00	92.2	7.3
28.3	1.67	2.00	2.00	92.0	7.1
28.4	1.67	2.00	2.00	91.7	6.8
28.4	1.67	2.00	2.00	91.5	6.6
28.5	1.67	2.00	2.00	91.2	6.3
28.6	1.67	2.00	2.00	91.0	6.1
28.6	1.67	2.00	2.00	90.7	5.8
28.7	1.67	2.00	2.00	90.5	5.6
28.7	1.67	2.00	2.00	90.2	5.3
28.8	1.67	2.00	2.00	90.0	5.1
28.9	1.67	2.00	2.00	89.7	4.8
28.9	1.67	2.00	2.00	89.5	4.5
29.0	1.67	2.00	2.00	89.2	4.3
29.0	1.67	2.00	2.00	89.0	4.0
29.1	1.67	2.00	2.00	88.7	3.8
29.2	1.67	2.00	2.00	88.5	3.5
29.2	1.67	2.00	2.00	88.2	3.3
29.3	1.67	2.00	2.00	88.0	3.0
29.3	1.67	2.00	2.00	87.7	2.8
29.4	1.67	2.00	2.00	87.5	2.5
29.5	1.67	2.00	2.00	87.2	2.3
29.5	1.67	2.00	2.00	87.0	2.0
29.6	1.67	2.00	2.00	86.7	1.8
29.6	1.67	2.00	2.00	86.5	1.5
29.7	1.67	2.00	2.00	86.2	1.3
29.8	1.67	2.00	2.00	86.0	1.0
29.8	1.67	2.00	2.00	85.7	0.8
29.9	1.67	2.00	2.00	85.5	0.5
29.9	1.67	2.00	2.00	85.2	0.3
30.0	1.67	2.00	2.00	85.0	0.0

Zs - Soil Depth, Depth from Ground Surface

Zp - Pile Depth, Depth from Pile Top

Sv - Vertical Effective Stress in Soils

Sf_dw - Uplift Side Resistance between Soil and Pile

Sf_up - Uplift Side Resistance between Soil and Pile

Q_dw - Downward Axial Force in Pile Shaft (Ultimate Uplift Capacity)

Q_up - Uplift Axial Force in Pile Shaft (Ultimate Uplift Capacity)

Vertical Load vs. Total Settlement

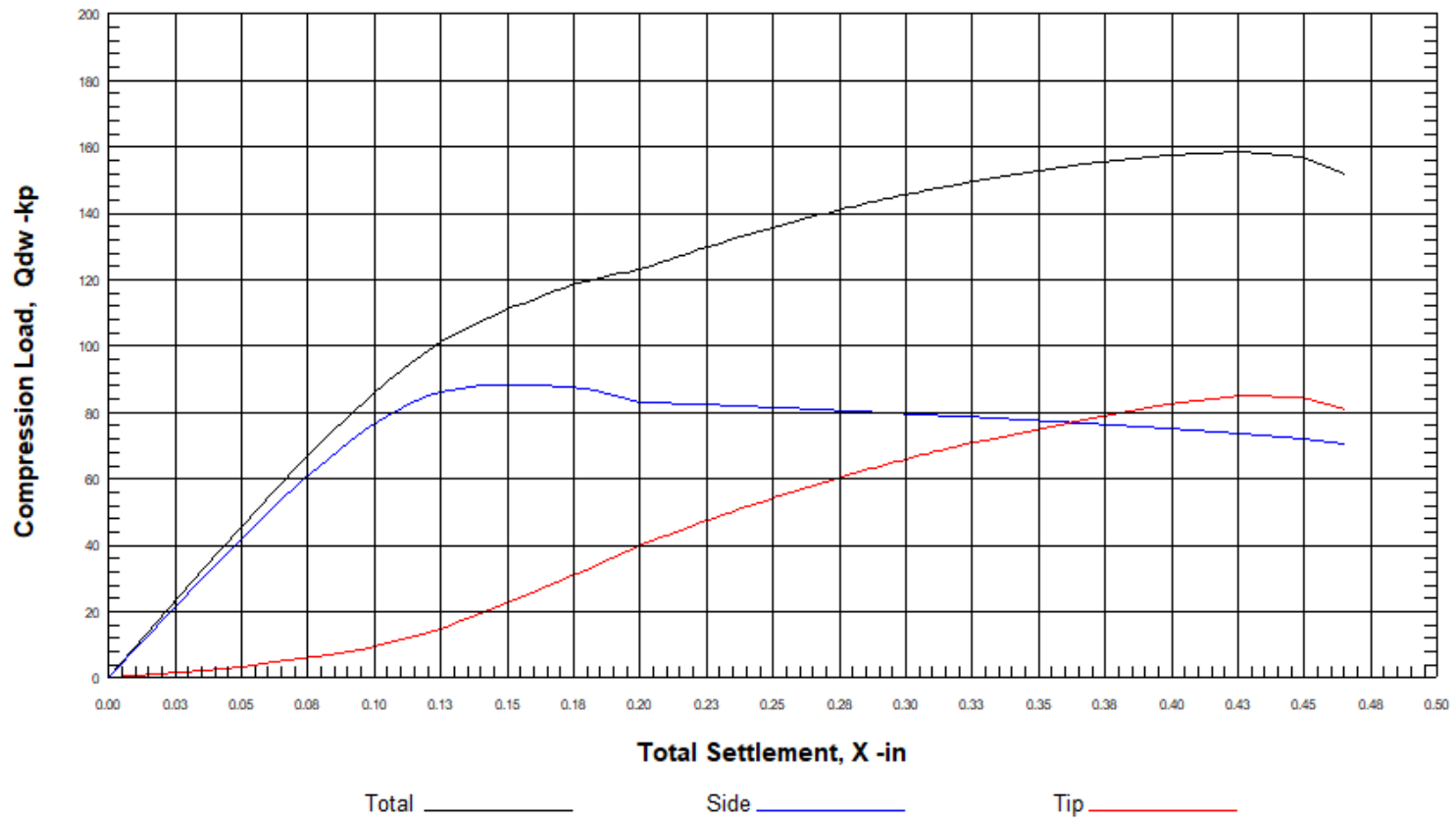

ØLoad_L

Vertical Side and Tip Resistance vs. Total Settlement:

Xtop -in	Qside -kp	Qtip -kp	Qtotal -kp
0.001	0.5	0.1	0.7
0.036	30.5	2.4	32.9
0.050	42.0	3.6	45.6
0.062	51.6	4.7	56.4
0.073	59.6	5.9	65.4
0.082	66.1	7.0	73.1
0.091	71.3	8.2	79.5
0.098	75.5	9.3	84.8
0.105	78.9	10.5	89.3
0.110	81.4	11.6	93.0
0.116	83.4	12.7	96.2
0.120	85.0	13.9	98.8
0.125	86.1	15.0	101.0
0.129	86.9	16.1	103.0
0.133	87.4	17.2	104.6
0.136	87.8	18.3	106.1
0.140	88.0	19.4	107.4
0.143	88.2	20.5	108.7
0.147	88.3	21.5	109.8
0.150	88.3	22.6	110.9
0.153	88.3	23.7	111.9
0.156	88.2	24.7	112.9
0.159	88.2	25.7	113.9
0.162	88.1	26.7	114.9
0.166	88.0	27.8	115.8
0.169	87.9	28.8	116.6
0.171	87.7	29.7	117.5
0.174	87.5	30.7	118.2
0.177	87.2	31.7	118.9
0.180	86.9	32.6	119.6
0.183	86.6	33.6	120.1
0.185	86.2	34.5	120.7
0.188	85.7	35.4	121.1
0.190	85.2	36.3	121.5
0.193	84.7	37.2	121.9
0.195	84.1	38.1	122.2
0.197	83.6	38.9	122.5
0.200	83.1	39.8	122.9
0.202	82.8	40.6	123.4
0.205	83.0	41.5	124.4
0.208	82.9	42.3	125.1
0.210	82.8	43.1	125.9
0.213	82.7	43.8	126.6
0.216	82.6	44.6	127.3
0.218	82.6	45.4	128.0
0.221	82.5	46.1	128.6
0.223	82.4	46.9	129.3
0.226	82.3	47.6	129.9
0.228	82.3	48.3	130.6
0.231	82.2	49.0	131.2
0.233	82.1	49.7	131.8
0.236	82.0	50.4	132.4
0.238	81.9	51.0	133.0
0.241	81.9	51.7	133.5
0.243	81.8	52.3	134.1
0.245	81.7	53.0	134.6
0.248	81.6	53.6	135.2
0.250	81.5	54.2	135.7

ØLoad_L

0.252	81.4	54.8	136.2
0.254	81.4	55.4	136.7
0.257	81.3	55.9	137.2
0.259	81.2	56.5	137.7
0.261	81.1	57.1	138.2
0.263	81.0	57.6	138.6
0.266	81.0	58.1	139.1
0.268	80.9	58.7	139.5
0.270	80.8	59.2	140.0
0.272	80.7	59.7	140.4
0.274	80.6	60.2	140.8
0.276	80.6	60.7	141.3
0.278	80.5	61.2	141.7
0.280	80.4	61.6	142.1
0.282	80.3	62.1	142.4
0.284	80.3	62.6	142.8
0.286	80.2	63.0	143.2
0.288	80.1	63.5	143.6
0.290	80.0	63.9	143.9
0.292	79.9	64.3	144.3
0.294	79.9	64.7	144.6
0.296	79.8	65.2	144.9
0.298	79.7	65.6	145.3
0.300	79.6	66.0	145.6
0.302	79.6	66.4	145.9
0.304	79.5	66.8	146.2
0.306	79.4	67.1	146.5
0.308	79.3	67.5	146.9
0.309	79.3	67.9	147.2
0.311	79.2	68.3	147.4
0.313	79.1	68.6	147.7
0.315	79.0	69.0	148.0
0.317	79.0	69.3	148.3
0.319	78.9	69.7	148.6
0.320	78.8	70.0	148.8
0.322	78.7	70.4	149.1
0.333	78.3	72.3	150.6
0.367	76.8	78.0	154.8
0.398	75.3	82.4	157.7
0.427	73.8	85.0	158.8
0.449	72.3	84.6	156.9
0.465	70.8	80.8	151.6

Xtop - Total Vertical Settlement
Qside - Vertical Side Resistance (Down)
Qtip - Vertical Tip Resistance (Down)
Qtotal - Vertical Total Resistance (Ultimate)

ULTIMATE CAPACITY vs FOUNDATION DEPTH

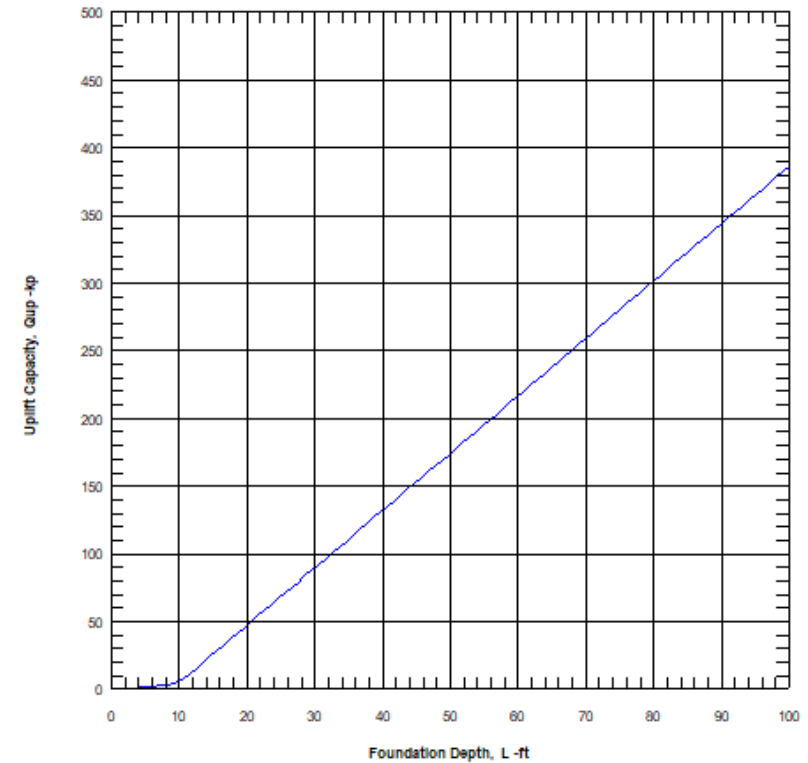
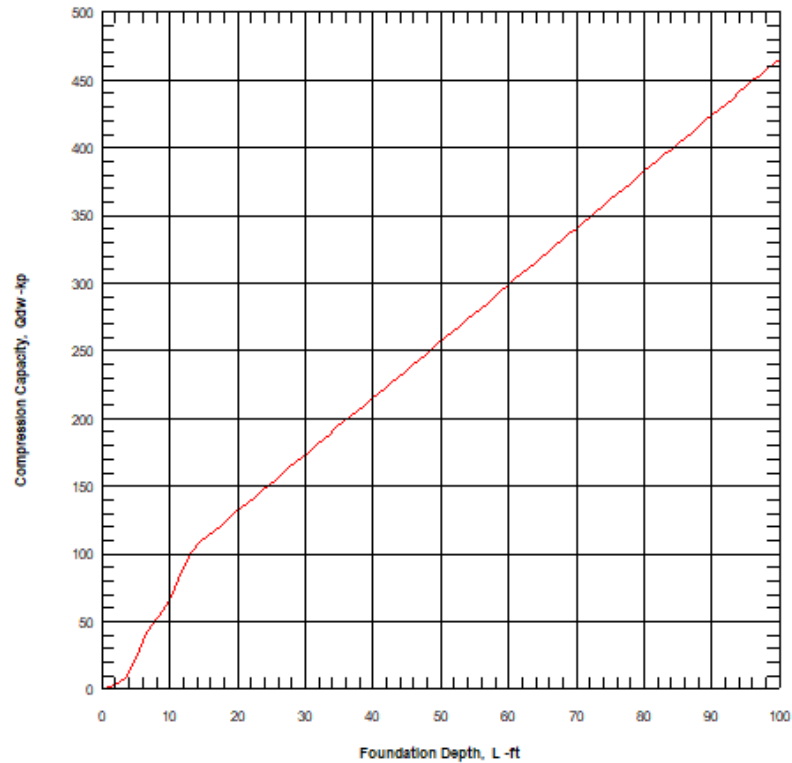

Downward and Uplift Capacity vs Pile Length

The results are for single section pile. Multiple sections may not be correct!

Length -ft	Qtip -kp	Qside -kp	Q_dw -kp	Qd_alw -kp	Weight -kp	Qsid* -kp	Q_up -kp	Qu_alw -kp
0.30	0.28	0.01	0.3	0.14	0.01	0.01	0.02	0.01
1.31	1.71	0.22	1.9	1.00	0.05	0.22	0.26	0.15
2.31	3.95	0.49	4.4	2.30	0.08	0.49	0.57	0.32
3.32	7.57	0.82	8.4	4.33	0.12	0.82	0.94	0.53
4.33	13.48	1.22	14.7	7.55	0.15	1.22	1.37	0.76
5.34	23.12	1.69	24.8	12.68	0.19	1.69	1.87	1.03
6.34	37.42	2.22	39.6	20.19	0.22	2.22	2.44	1.33
7.35	44.06	2.81	46.9	23.91	0.26	2.81	3.07	1.66
8.36	50.70	3.48	54.2	27.67	0.29	3.48	3.77	2.03
9.36	57.33	4.22	61.6	31.48	0.33	4.22	4.55	2.44
10.37	64.15	6.25	70.4	36.24	0.37	6.25	6.62	3.50
11.38	70.60	10.43	81.0	42.25	0.43	10.42	10.85	5.64
12.38	77.46	14.69	92.1	48.52	0.48	14.69	15.17	7.83
13.39	83.88	18.84	102.7	54.50	0.54	18.84	19.38	9.96
14.40	85.10	23.11	108.2	57.96	0.60	23.11	23.71	12.15
15.41	84.95	27.23	112.2	60.63	0.65	27.23	27.89	14.27
16.41	85.25	31.44	116.7	63.58	0.71	31.44	32.15	16.43
17.42	85.05	35.69	120.7	66.32	0.77	35.69	36.45	18.61
18.43	85.17	39.93	125.1	69.21	0.82	39.93	40.75	20.79
19.43	85.19	44.13	129.3	72.02	0.88	44.14	45.01	22.95
20.44	85.04	48.39	133.4	74.78	0.93	48.39	49.33	25.13
21.45	85.17	52.54	137.7	77.61	0.99	52.54	53.53	27.26
22.46	85.02	56.69	141.7	80.30	1.05	56.69	57.74	29.39
23.46	85.25	60.98	146.2	83.27	1.10	60.98	62.08	31.59
24.47	84.98	65.23	150.2	85.98	1.16	65.23	66.39	33.78
25.48	85.20	69.44	154.6	88.89	1.22	69.44	70.66	35.94
26.48	84.99	73.58	158.6	91.55	1.27	73.58	74.85	38.06
27.49	85.38	77.82	163.2	94.57	1.33	77.82	79.15	40.24
28.50	85.04	81.96	167.0	97.16	1.38	81.96	83.34	42.36
29.51	85.29	86.18	171.5	100.10	1.44	86.18	87.62	44.53
30.51	84.91	90.48	175.4	102.78	1.50	90.48	91.98	46.74
31.52	85.16	94.66	179.8	105.68	1.55	94.66	96.21	48.88
32.53	85.20	98.90	184.1	108.53	1.61	98.90	100.51	51.06
33.53	84.87	102.98	187.9	111.09	1.67	102.98	104.65	53.16
34.54	85.24	107.35	192.6	114.19	1.72	107.35	109.08	55.40
35.55	85.05	111.55	196.6	116.89	1.78	111.55	113.33	57.56
36.55	85.14	115.56	200.7	119.61	1.84	115.56	117.40	59.62
37.56	85.11	119.87	205.0	122.47	1.89	119.87	121.76	61.83
38.57	84.95	124.22	209.2	125.29	1.95	124.22	126.17	64.06
39.58	85.18	128.37	213.5	128.17	2.01	128.37	130.37	66.19
40.58	84.77	132.56	217.3	130.76	2.06	132.55	134.62	68.34
41.59	84.78	136.78	221.6	133.58	2.12	136.78	138.90	70.51
42.60	85.25	141.05	226.3	136.66	2.18	141.05	143.23	72.70
43.60	85.02	145.07	230.1	139.22	2.23	145.07	147.30	74.76
44.61	84.74	149.41	234.2	141.98	2.29	149.41	151.70	76.99
45.62	84.95	153.49	238.4	144.80	2.34	153.49	155.83	79.09
46.63	85.04	157.91	242.9	147.79	2.40	157.91	160.31	81.35
47.63	85.06	162.05	247.1	150.56	2.46	162.04	164.50	83.48
48.64	85.04	166.21	251.3	153.33	2.51	166.21	168.73	85.62
49.65	84.90	170.40	255.3	156.05	2.57	170.40	172.97	87.77
50.65	85.34	174.63	260.0	159.09	2.63	174.62	177.25	89.94
51.66	85.06	178.87	263.9	161.78	2.68	178.87	181.55	92.12
52.67	84.70	183.15	267.8	164.45	2.74	183.15	185.89	94.31
53.67	84.96	187.09	272.0	167.20	2.79	187.09	189.88	96.34
54.68	85.18	191.41	276.6	170.20	2.85	191.41	194.26	98.56
55.69	85.34	195.76	281.1	173.18	2.91	195.76	198.67	100.79
56.70	84.71	199.75	284.5	175.52	2.96	199.75	202.72	102.84
57.70	84.76	204.15	288.9	178.48	3.02	204.15	207.17	105.10
58.71	84.75	208.18	292.9	181.16	3.08	208.18	211.26	107.17
59.72	84.70	212.63	297.3	184.10	3.13	212.63	215.76	109.45

					ØLoad_L			
60.72	85.39	216.69	302.1	187.16	3.19	216.69	219.88	111.53
61.73	85.25	220.77	306.0	189.80	3.24	220.77	224.01	113.63
62.74	85.05	225.28	310.3	192.71	3.30	225.28	228.59	115.94
63.75	84.74	229.39	314.1	195.30	3.36	229.39	232.75	118.05
64.75	85.30	233.52	318.8	198.33	3.41	233.52	236.93	120.17
65.76	84.96	237.66	322.6	200.92	3.47	237.66	241.13	122.30
66.77	85.38	241.81	327.2	203.90	3.53	241.81	245.33	124.43
67.77	84.96	245.97	330.9	206.46	3.58	245.97	249.55	126.57
68.78	85.39	250.62	336.0	209.77	3.64	250.62	254.26	128.95
69.79	84.80	254.81	339.6	212.28	3.70	254.81	258.51	131.10
70.79	85.17	259.03	344.2	215.27	3.75	259.03	262.78	133.27
71.80	84.56	263.26	347.8	217.78	3.81	263.25	267.07	135.44
72.81	84.79	267.01	351.8	220.40	3.86	267.00	270.87	137.37
73.82	85.07	271.25	356.3	223.37	3.92	271.25	275.18	139.55
74.82	85.24	275.51	360.8	226.30	3.98	275.51	279.49	141.73
75.83	85.47	279.79	365.3	229.26	4.03	279.79	283.82	143.93
76.84	84.58	284.07	368.7	231.67	4.09	284.08	288.17	146.13
77.84	84.74	288.38	373.1	234.62	4.15	288.38	292.52	148.34
78.85	84.80	292.69	377.5	237.53	4.21	292.69	296.90	150.55
79.86	84.92	296.48	381.4	240.11	4.26	296.49	300.74	152.50
80.87	84.92	300.82	385.7	243.01	4.32	300.82	305.13	154.72
81.87	84.99	305.17	390.2	245.94	4.37	305.17	309.54	156.96
82.88	84.94	309.53	394.5	248.82	4.43	309.53	313.96	159.20
83.89	84.95	313.34	398.3	251.37	4.48	313.34	317.83	161.16
84.89	84.85	317.72	402.6	254.24	4.54	317.73	322.27	163.41
85.90	84.82	322.12	406.9	257.16	4.60	322.12	326.72	165.66
86.91	84.67	325.95	410.6	259.63	4.65	325.95	330.60	167.63
87.92	84.49	330.36	414.9	262.49	4.71	330.36	335.08	169.89
88.92	85.55	334.80	420.3	265.97	4.77	334.80	339.57	172.17
89.93	85.33	338.64	424.0	268.42	4.82	338.63	343.46	174.14
90.94	85.09	343.08	428.2	271.27	4.88	343.09	347.97	176.42
91.94	84.92	346.93	431.8	273.75	4.94	346.93	351.87	178.40
92.95	84.62	351.40	436.0	276.58	4.99	351.40	356.39	180.69
93.96	85.63	355.89	441.5	280.08	5.05	355.89	360.94	183.00
94.96	85.30	359.75	445.0	282.48	5.11	359.75	364.85	184.98
95.97	84.94	364.26	449.2	285.31	5.16	364.25	369.42	187.29
96.98	84.65	368.12	452.8	287.74	5.22	368.12	373.34	189.28
97.99	85.53	372.65	458.2	291.20	5.28	372.65	377.92	191.60
98.99	85.11	376.52	461.6	293.57	5.33	376.52	381.85	193.59
100.00	84.65	381.06	465.7	296.37	5.39	381.06	386.45	195.92

FACTOR OF SAFETY:

FSside	FStip	FSup	FSweight
1.5	2.0	2.0	1.0

Note: Data can be selected, copied and pasted to Excel to create graphics
 Length - Pile length, distance from pile top to tip (not from ground surface)
 Qtip - Ultimate pile tip resistance
 Qside - Ultimate pile side resistance
 Q_dw - Ultimate pile downward resistance
 Qd_alw - Allowable pile downward resistance
 Weight - Weight of pile shaft
 Qsid* - Ultimate pile side uplift resistance
 Q_up - Ultimate pile uplift resistance
 Qu_alw - Allowable pile uplift resistance

Side Resistance vs. Relative Movement between Soil and Shaft (t-z)

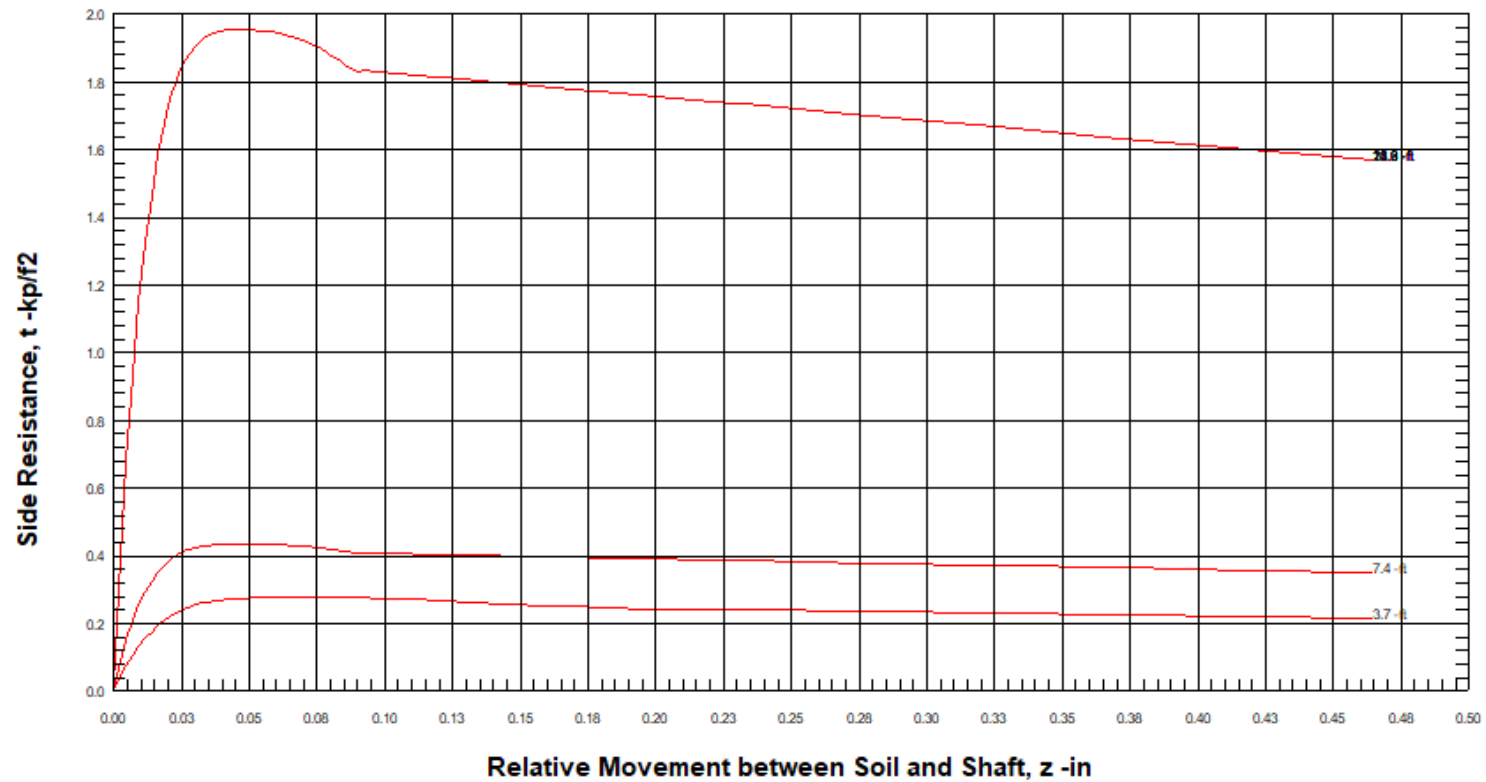

Soil Depth (Zs): 3.7, 7.4, 11.2, 14.9, 18.6, 22.3, 26.0 -ft



ØLoad_L

Side Resistance vs. Relative Movement between Soil and Shaft (t-z)

Zs -ft	t -kp/f2	z -in
3.72	0.00	0.00
3.72	0.08	0.00
3.72	0.11	0.01
3.72	0.13	0.01
3.72	0.16	0.01
3.72	0.18	0.01
3.72	0.19	0.02
3.72	0.21	0.02
3.72	0.22	0.02
3.72	0.23	0.02
3.72	0.24	0.03
3.72	0.25	0.03
3.72	0.25	0.03
3.72	0.26	0.03
3.72	0.26	0.03
3.72	0.27	0.04
3.72	0.27	0.04
3.72	0.27	0.04
3.72	0.27	0.04
3.72	0.27	0.04
3.72	0.27	0.05
3.72	0.28	0.05
3.72	0.28	0.05
3.72	0.28	0.05
3.72	0.28	0.05
3.72	0.28	0.06
3.72	0.28	0.06
3.72	0.28	0.06
3.72	0.28	0.06
3.72	0.28	0.06
3.72	0.28	0.07
3.72	0.28	0.07
3.72	0.28	0.07
3.72	0.28	0.07
3.72	0.28	0.07
3.72	0.28	0.08
3.72	0.28	0.08
3.72	0.28	0.08
3.72	0.28	0.08
3.72	0.28	0.09
3.72	0.28	0.09
3.72	0.28	0.09
3.72	0.28	0.09
3.72	0.28	0.10
3.72	0.28	0.10
3.72	0.27	0.10
3.72	0.27	0.10
3.72	0.27	0.10
3.72	0.27	0.11
3.72	0.27	0.11
3.72	0.27	0.11
3.72	0.27	0.11
3.72	0.27	0.12
3.72	0.27	0.12
3.72	0.27	0.12
3.72	0.27	0.12
3.72	0.27	0.13
3.72	0.26	0.13
3.72	0.26	0.13
3.72	0.26	0.13
3.72	0.26	0.13

ØLoad_L

3.72	0.26	0.14
3.72	0.26	0.14
3.72	0.26	0.14
3.72	0.26	0.14
3.72	0.26	0.15
3.72	0.26	0.15
3.72	0.25	0.15
3.72	0.25	0.15
3.72	0.25	0.16
3.72	0.25	0.16
3.72	0.25	0.16
3.72	0.25	0.16
3.72	0.25	0.16
3.72	0.25	0.17
3.72	0.25	0.17
3.72	0.25	0.17
3.72	0.25	0.17
3.72	0.25	0.18
3.72	0.25	0.18
3.72	0.25	0.18
3.72	0.24	0.18
3.72	0.24	0.19
3.72	0.24	0.19
3.72	0.24	0.19
3.72	0.24	0.19
3.72	0.24	0.20
3.72	0.24	0.20
3.72	0.24	0.20
3.72	0.24	0.20
3.72	0.24	0.20
3.72	0.24	0.21
3.72	0.24	0.21
3.72	0.24	0.21
3.72	0.24	0.21
3.72	0.24	0.22
3.72	0.24	0.22
3.72	0.24	0.23
3.72	0.23	0.28
3.72	0.23	0.33
3.72	0.22	0.37
3.72	0.22	0.42
3.72	0.21	0.46

Zs	t	z
-ft	-kp/f2	-in
7.44	0.00	0.00
7.44	0.15	0.00
7.44	0.21	0.01
7.44	0.26	0.01
7.44	0.30	0.01
7.44	0.33	0.01
7.44	0.35	0.02
7.44	0.37	0.02
7.44	0.39	0.02
7.44	0.40	0.02
7.44	0.41	0.03
7.44	0.42	0.03
7.44	0.43	0.03
7.44	0.43	0.03
7.44	0.43	0.03
7.44	0.43	0.04
7.44	0.43	0.04
7.44	0.44	0.04
7.44	0.44	0.04
7.44	0.44	0.05
7.44	0.44	0.05

ØLoad_L

7.44	0.44	0.05
7.44	0.44	0.05
7.44	0.43	0.06
7.44	0.43	0.06
7.44	0.43	0.06
7.44	0.43	0.06
7.44	0.43	0.07
7.44	0.43	0.07
7.44	0.43	0.07
7.44	0.43	0.07
7.44	0.42	0.07
7.44	0.42	0.08
7.44	0.42	0.08
7.44	0.42	0.08
7.44	0.41	0.08
7.44	0.41	0.09
7.44	0.41	0.09
7.44	0.41	0.09
7.44	0.41	0.09
7.44	0.41	0.10
7.44	0.41	0.10
7.44	0.41	0.10
7.44	0.41	0.10
7.44	0.41	0.10
7.44	0.41	0.11
7.44	0.41	0.11
7.44	0.41	0.11
7.44	0.41	0.11
7.44	0.40	0.12
7.44	0.40	0.12
7.44	0.40	0.12
7.44	0.40	0.12
7.44	0.40	0.12
7.44	0.40	0.13
7.44	0.40	0.13
7.44	0.40	0.13
7.44	0.40	0.13
7.44	0.40	0.13
7.44	0.40	0.14
7.44	0.40	0.14
7.44	0.40	0.14
7.44	0.40	0.14
7.44	0.40	0.14
7.44	0.40	0.15
7.44	0.40	0.15
7.44	0.40	0.15
7.44	0.40	0.15
7.44	0.40	0.16
7.44	0.40	0.16
7.44	0.40	0.16
7.44	0.40	0.16
7.44	0.40	0.16
7.44	0.40	0.17
7.44	0.40	0.17
7.44	0.40	0.17
7.44	0.40	0.17
7.44	0.40	0.17
7.44	0.40	0.18
7.44	0.39	0.18
7.44	0.39	0.18
7.44	0.39	0.18
7.44	0.39	0.19
7.44	0.39	0.19
7.44	0.39	0.19
7.44	0.39	0.19
7.44	0.39	0.20
7.44	0.39	0.20
7.44	0.39	0.20
7.44	0.39	0.20
7.44	0.39	0.20

ØLoad_L

7.44	0.39	0.21
7.44	0.39	0.21
7.44	0.39	0.21
7.44	0.39	0.21
7.44	0.39	0.22
7.44	0.39	0.22
7.44	0.39	0.23
7.44	0.38	0.28
7.44	0.37	0.33
7.44	0.36	0.37
7.44	0.36	0.42
7.44	0.35	0.46

Zs	t	z
-ft	-kp/f2	-in
11.16	0.01	0.00
11.16	0.68	0.00
11.16	0.94	0.01
11.16	1.15	0.01
11.16	1.32	0.01
11.16	1.47	0.01
11.16	1.58	0.02
11.16	1.68	0.02
11.16	1.75	0.02
11.16	1.81	0.02
11.16	1.85	0.03
11.16	1.88	0.03
11.16	1.91	0.03
11.16	1.93	0.03
11.16	1.94	0.03
11.16	1.95	0.04
11.16	1.95	0.04
11.16	1.95	0.04
11.16	1.95	0.04
11.16	1.96	0.05
11.16	1.95	0.05
11.16	1.95	0.05
11.16	1.95	0.05
11.16	1.95	0.05
11.16	1.95	0.06
11.16	1.95	0.06
11.16	1.95	0.06
11.16	1.94	0.06
11.16	1.94	0.07
11.16	1.93	0.07
11.16	1.92	0.07
11.16	1.92	0.07
11.16	1.91	0.07
11.16	1.90	0.08
11.16	1.88	0.08
11.16	1.87	0.08
11.16	1.86	0.08
11.16	1.85	0.09
11.16	1.84	0.09
11.16	1.83	0.09
11.16	1.83	0.09
11.16	1.83	0.10
11.16	1.83	0.10
11.16	1.83	0.10
11.16	1.83	0.10
11.16	1.83	0.10
11.16	1.82	0.11
11.16	1.82	0.11
11.16	1.82	0.11
11.16	1.82	0.11
11.16	1.82	0.12
11.16	1.82	0.12

ØLoad_L

11.16	1.81	0.12
11.16	1.81	0.12
11.16	1.81	0.13
11.16	1.81	0.13
11.16	1.81	0.13
11.16	1.81	0.13
11.16	1.80	0.13
11.16	1.80	0.14
11.16	1.80	0.14
11.16	1.80	0.14
11.16	1.80	0.14
11.16	1.80	0.15
11.16	1.79	0.15
11.16	1.79	0.15
11.16	1.79	0.15
11.16	1.79	0.16
11.16	1.79	0.16
11.16	1.79	0.16
11.16	1.78	0.16
11.16	1.78	0.16
11.16	1.78	0.17
11.16	1.78	0.17
11.16	1.78	0.17
11.16	1.78	0.17
11.16	1.77	0.18
11.16	1.77	0.18
11.16	1.77	0.18
11.16	1.77	0.18
11.16	1.77	0.19
11.16	1.77	0.19
11.16	1.76	0.19
11.16	1.76	0.19
11.16	1.76	0.20
11.16	1.76	0.20
11.16	1.76	0.20
11.16	1.76	0.20
11.16	1.75	0.20
11.16	1.75	0.21
11.16	1.75	0.21
11.16	1.75	0.21
11.16	1.75	0.21
11.16	1.75	0.22
11.16	1.74	0.22
11.16	1.73	0.23
11.16	1.70	0.28
11.16	1.67	0.33
11.16	1.63	0.37
11.16	1.60	0.42
11.16	1.57	0.46

Zs	t	z
-ft	-kp/f2	-in

14.88	0.01	0.00
14.88	0.68	0.00
14.88	0.94	0.01
14.88	1.15	0.01
14.88	1.32	0.01
14.88	1.47	0.01
14.88	1.58	0.02
14.88	1.68	0.02
14.88	1.75	0.02
14.88	1.81	0.02
14.88	1.85	0.03
14.88	1.88	0.03
14.88	1.91	0.03
14.88	1.93	0.03

ØLoad_L

14.88	1.94	0.03
14.88	1.95	0.04
14.88	1.95	0.04
14.88	1.95	0.04
14.88	1.95	0.04
14.88	1.96	0.05
14.88	1.95	0.05
14.88	1.95	0.05
14.88	1.95	0.05
14.88	1.95	0.06
14.88	1.95	0.06
14.88	1.95	0.06
14.88	1.94	0.06
14.88	1.94	0.07
14.88	1.93	0.07
14.88	1.92	0.07
14.88	1.92	0.07
14.88	1.91	0.07
14.88	1.90	0.08
14.88	1.88	0.08
14.88	1.87	0.08
14.88	1.86	0.08
14.88	1.85	0.09
14.88	1.84	0.09
14.88	1.83	0.09
14.88	1.83	0.09
14.88	1.83	0.10
14.88	1.83	0.10
14.88	1.83	0.10
14.88	1.83	0.10
14.88	1.83	0.10
14.88	1.82	0.11
14.88	1.82	0.11
14.88	1.82	0.11
14.88	1.82	0.11
14.88	1.82	0.12
14.88	1.82	0.12
14.88	1.81	0.12
14.88	1.81	0.12
14.88	1.81	0.13
14.88	1.81	0.13
14.88	1.81	0.13
14.88	1.81	0.13
14.88	1.80	0.13
14.88	1.80	0.14
14.88	1.80	0.14
14.88	1.80	0.14
14.88	1.80	0.14
14.88	1.80	0.15
14.88	1.79	0.15
14.88	1.79	0.15
14.88	1.79	0.15
14.88	1.79	0.16
14.88	1.79	0.16
14.88	1.79	0.16
14.88	1.78	0.16
14.88	1.78	0.16
14.88	1.78	0.16
14.88	1.78	0.17
14.88	1.78	0.17
14.88	1.78	0.17
14.88	1.78	0.17
14.88	1.77	0.18
14.88	1.77	0.18
14.88	1.77	0.18
14.88	1.77	0.18
14.88	1.77	0.19
14.88	1.77	0.19

0Load_L

14.88	1.76	0.19
14.88	1.76	0.19
14.88	1.76	0.20
14.88	1.76	0.20
14.88	1.76	0.20
14.88	1.76	0.20
14.88	1.75	0.20
14.88	1.75	0.21
14.88	1.75	0.21
14.88	1.75	0.21
14.88	1.75	0.21
14.88	1.75	0.22
14.88	1.74	0.22
14.88	1.73	0.23
14.88	1.70	0.28
14.88	1.67	0.33
14.88	1.63	0.37
14.88	1.60	0.42
14.88	1.57	0.46

Zs	t	z
-ft	-kp/f2	-in
18.59	0.01	0.00
18.59	0.68	0.00
18.59	0.94	0.01
18.59	1.15	0.01
18.59	1.32	0.01
18.59	1.47	0.01
18.59	1.58	0.02
18.59	1.68	0.02
18.59	1.75	0.02
18.59	1.81	0.02
18.59	1.85	0.03
18.59	1.88	0.03
18.59	1.91	0.03
18.59	1.93	0.03
18.59	1.94	0.03
18.59	1.95	0.04
18.59	1.95	0.04
18.59	1.95	0.04
18.59	1.95	0.04
18.59	1.96	0.05
18.59	1.95	0.05
18.59	1.95	0.05
18.59	1.95	0.05
18.59	1.95	0.05
18.59	1.95	0.06
18.59	1.95	0.06
18.59	1.95	0.06
18.59	1.94	0.06
18.59	1.94	0.07
18.59	1.93	0.07
18.59	1.92	0.07
18.59	1.92	0.07
18.59	1.91	0.07
18.59	1.90	0.08
18.59	1.88	0.08
18.59	1.87	0.08
18.59	1.86	0.08
18.59	1.85	0.09
18.59	1.84	0.09
18.59	1.83	0.09
18.59	1.83	0.09
18.59	1.83	0.10
18.59	1.83	0.10
18.59	1.83	0.10
18.59	1.83	0.10

ØLoad_L

18.59	1.83	0.10
18.59	1.82	0.11
18.59	1.82	0.11
18.59	1.82	0.11
18.59	1.82	0.11
18.59	1.82	0.12
18.59	1.82	0.12
18.59	1.81	0.12
18.59	1.81	0.12
18.59	1.81	0.13
18.59	1.81	0.13
18.59	1.81	0.13
18.59	1.81	0.13
18.59	1.80	0.13
18.59	1.80	0.14
18.59	1.80	0.14
18.59	1.80	0.14
18.59	1.80	0.14
18.59	1.80	0.15
18.59	1.79	0.15
18.59	1.79	0.15
18.59	1.79	0.15
18.59	1.79	0.16
18.59	1.79	0.16
18.59	1.79	0.16
18.59	1.78	0.16
18.59	1.78	0.16
18.59	1.78	0.17
18.59	1.78	0.17
18.59	1.78	0.17
18.59	1.78	0.17
18.59	1.77	0.18
18.59	1.77	0.18
18.59	1.77	0.18
18.59	1.77	0.18
18.59	1.77	0.19
18.59	1.77	0.19
18.59	1.76	0.19
18.59	1.76	0.19
18.59	1.76	0.20
18.59	1.76	0.20
18.59	1.76	0.20
18.59	1.76	0.20
18.59	1.75	0.20
18.59	1.75	0.21
18.59	1.75	0.21
18.59	1.75	0.21
18.59	1.75	0.21
18.59	1.75	0.22
18.59	1.74	0.22
18.59	1.73	0.23
18.59	1.70	0.28
18.59	1.67	0.33
18.59	1.63	0.37
18.59	1.60	0.42
18.59	1.57	0.46

Zs	t	z
-ft	-kp/f2	-in
22.31	0.01	0.00
22.31	0.68	0.00
22.31	0.94	0.01
22.31	1.15	0.01
22.31	1.32	0.01
22.31	1.47	0.01
22.31	1.58	0.02

ØLoad_L

22.31	1.68	0.02
22.31	1.75	0.02
22.31	1.81	0.02
22.31	1.85	0.03
22.31	1.88	0.03
22.31	1.91	0.03
22.31	1.93	0.03
22.31	1.94	0.03
22.31	1.95	0.04
22.31	1.95	0.04
22.31	1.95	0.04
22.31	1.95	0.04
22.31	1.96	0.05
22.31	1.95	0.05
22.31	1.95	0.05
22.31	1.95	0.05
22.31	1.95	0.06
22.31	1.95	0.06
22.31	1.95	0.06
22.31	1.94	0.06
22.31	1.94	0.07
22.31	1.93	0.07
22.31	1.92	0.07
22.31	1.92	0.07
22.31	1.91	0.07
22.31	1.90	0.08
22.31	1.88	0.08
22.31	1.87	0.08
22.31	1.86	0.08
22.31	1.85	0.09
22.31	1.84	0.09
22.31	1.83	0.09
22.31	1.83	0.09
22.31	1.83	0.10
22.31	1.83	0.10
22.31	1.83	0.10
22.31	1.83	0.10
22.31	1.83	0.10
22.31	1.82	0.11
22.31	1.82	0.11
22.31	1.82	0.11
22.31	1.82	0.11
22.31	1.82	0.12
22.31	1.82	0.12
22.31	1.81	0.12
22.31	1.81	0.12
22.31	1.81	0.13
22.31	1.81	0.13
22.31	1.81	0.13
22.31	1.81	0.13
22.31	1.80	0.13
22.31	1.80	0.14
22.31	1.80	0.14
22.31	1.80	0.14
22.31	1.80	0.14
22.31	1.80	0.15
22.31	1.79	0.15
22.31	1.79	0.15
22.31	1.79	0.15
22.31	1.79	0.16
22.31	1.79	0.16
22.31	1.79	0.16
22.31	1.78	0.16
22.31	1.78	0.16
22.31	1.78	0.17
22.31	1.78	0.17
22.31	1.78	0.17

ØLoad_L

22.31	1.78	0.17
22.31	1.77	0.18
22.31	1.77	0.18
22.31	1.77	0.18
22.31	1.77	0.18
22.31	1.77	0.19
22.31	1.77	0.19
22.31	1.76	0.19
22.31	1.76	0.19
22.31	1.76	0.20
22.31	1.76	0.20
22.31	1.76	0.20
22.31	1.76	0.20
22.31	1.75	0.20
22.31	1.75	0.21
22.31	1.75	0.21
22.31	1.75	0.21
22.31	1.75	0.21
22.31	1.75	0.22
22.31	1.74	0.22
22.31	1.73	0.23
22.31	1.70	0.28
22.31	1.67	0.33
22.31	1.63	0.37
22.31	1.60	0.42
22.31	1.57	0.46

Zs	t	z
-ft	-kp/f2	-in
26.03	0.01	0.00
26.03	0.68	0.00
26.03	0.94	0.01
26.03	1.15	0.01
26.03	1.32	0.01
26.03	1.47	0.01
26.03	1.58	0.02
26.03	1.68	0.02
26.03	1.75	0.02
26.03	1.81	0.02
26.03	1.85	0.03
26.03	1.88	0.03
26.03	1.91	0.03
26.03	1.93	0.03
26.03	1.94	0.03
26.03	1.95	0.04
26.03	1.95	0.04
26.03	1.95	0.04
26.03	1.95	0.04
26.03	1.96	0.05
26.03	1.95	0.05
26.03	1.95	0.05
26.03	1.95	0.05
26.03	1.95	0.06
26.03	1.95	0.06
26.03	1.95	0.06
26.03	1.94	0.06
26.03	1.94	0.07
26.03	1.93	0.07
26.03	1.92	0.07
26.03	1.92	0.07
26.03	1.91	0.07
26.03	1.90	0.08
26.03	1.88	0.08
26.03	1.87	0.08
26.03	1.86	0.08
26.03	1.85	0.09

ØLoad_L

26.03	1.84	0.09
26.03	1.83	0.09
26.03	1.83	0.09
26.03	1.83	0.10
26.03	1.83	0.10
26.03	1.83	0.10
26.03	1.83	0.10
26.03	1.82	0.11
26.03	1.82	0.11
26.03	1.82	0.11
26.03	1.82	0.11
26.03	1.82	0.12
26.03	1.82	0.12
26.03	1.81	0.12
26.03	1.81	0.12
26.03	1.81	0.13
26.03	1.81	0.13
26.03	1.81	0.13
26.03	1.81	0.13
26.03	1.80	0.13
26.03	1.80	0.14
26.03	1.80	0.14
26.03	1.80	0.14
26.03	1.80	0.14
26.03	1.80	0.15
26.03	1.79	0.15
26.03	1.79	0.15
26.03	1.79	0.15
26.03	1.79	0.16
26.03	1.79	0.16
26.03	1.79	0.16
26.03	1.78	0.16
26.03	1.78	0.16
26.03	1.78	0.17
26.03	1.78	0.17
26.03	1.78	0.17
26.03	1.78	0.17
26.03	1.77	0.18
26.03	1.77	0.18
26.03	1.77	0.18
26.03	1.77	0.18
26.03	1.77	0.19
26.03	1.77	0.19
26.03	1.76	0.19
26.03	1.76	0.19
26.03	1.76	0.20
26.03	1.76	0.20
26.03	1.76	0.20
26.03	1.76	0.20
26.03	1.75	0.20
26.03	1.75	0.21
26.03	1.75	0.21
26.03	1.75	0.21
26.03	1.75	0.21
26.03	1.75	0.22
26.03	1.74	0.22
26.03	1.73	0.23
26.03	1.70	0.28
26.03	1.67	0.33
26.03	1.63	0.37
26.03	1.60	0.42
26.03	1.57	0.46

Zs - Depth from Soil Top
t - Side Resistance
z - Relative Movement between Soil and Shaft

0Load_L

Tip Resistance vs. Tip Movement (q-w)

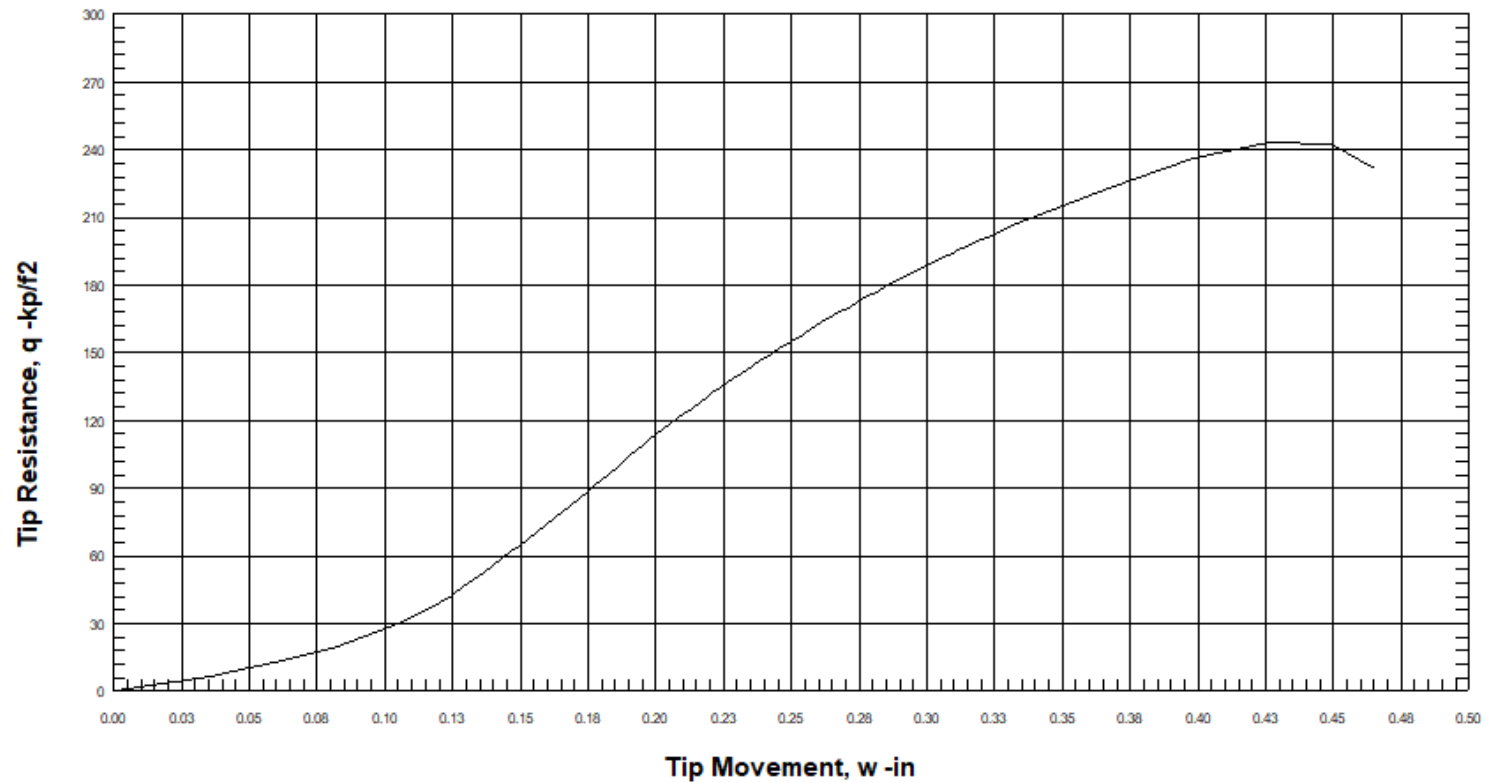

Tip Resistance vs. Tip Movement (q-w)

Depth of Pile Tip from Ground Surface = 29.75-ft

q -kp/f2	w -in
0.32	0.00
6.91	0.04
10.21	0.05
13.51	0.06
16.81	0.07
20.11	0.08
23.40	0.09
26.68	0.10
29.95	0.10
33.20	0.11
36.44	0.12
39.67	0.12
42.88	0.12
46.07	0.13
49.23	0.13
52.38	0.14
55.50	0.14
58.60	0.14
61.66	0.15
64.71	0.15
67.72	0.15
70.70	0.16
73.66	0.16
76.58	0.16
79.47	0.17
82.33	0.17
85.15	0.17
87.95	0.17
90.70	0.18
93.42	0.18
96.11	0.18
98.76	0.19
101.38	0.19
103.96	0.19
106.50	0.19
109.01	0.19
111.48	0.20
113.91	0.20
116.31	0.20
118.67	0.21
120.99	0.21
123.28	0.21
125.53	0.21
127.74	0.22
129.92	0.22
132.06	0.22
134.17	0.22
136.24	0.23
138.28	0.23
140.28	0.23
142.25	0.23
144.18	0.24
146.08	0.24
147.95	0.24
149.78	0.24
151.59	0.25
153.36	0.25

ØLoad_L

155.10	0.25
156.81	0.25
158.48	0.25
160.13	0.26
161.75	0.26
163.34	0.26
164.91	0.26
166.44	0.27
167.95	0.27
169.43	0.27
170.89	0.27
172.32	0.27
173.72	0.28
175.10	0.28
176.46	0.28
177.79	0.28
179.11	0.28
180.40	0.29
181.67	0.29
182.91	0.29
184.14	0.29
185.35	0.29
186.54	0.30
187.71	0.30
188.86	0.30
190.00	0.30
191.12	0.30
192.22	0.31
193.30	0.31
194.37	0.31
195.43	0.31
196.47	0.31
197.49	0.31
198.51	0.32
199.51	0.32
200.49	0.32
201.47	0.32
207.06	0.33
223.28	0.37
235.96	0.40
243.30	0.43
242.29	0.45
231.36	0.47

q - Tip Resistance
w - Tip Movement

LATERAL ANALYSIS

Figure 2

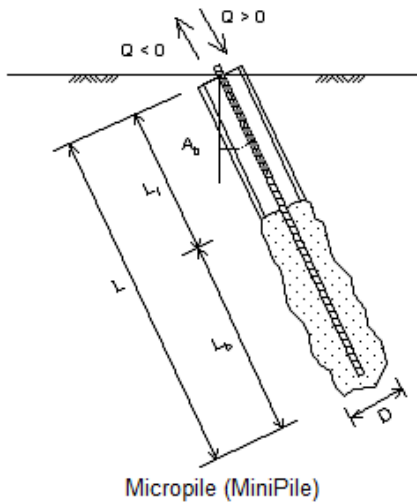

Loads:

Load Factor for Vertical Loads= 1.0
 Load Factor for Lateral Loads= 1.0
 Loads Supported by Pile Cap= 0 %
 Shear Condition: Static

(with Load Factor)

Vertical Load, Q= 150.0 -kp
 Shear Load, P= 8.5 -kp
 Slope Restrain St= 0.00000 -in/-in

Profile:

Pile Length, L= 30.0 -ft
 Top Height, H= 0.25 -ft
 Slope Angle, As= 0
 Batter Angle, Ab= 0
 Fixed Head Condition

Soil Data:

Depth -ft	Gamma -lb/f3	Phi	C -kp/f2	K -lb/i3	e50 or Dr %	Nspt
0	120	30.0	0.10	331.6	0.85	10
6	130	40.0	0.10	278.0	85.61	50

Pile Data:

Depth -ft	Width -in	Area -in2	Per. -in	I -in4	E -kp/i2	Weight -kp/f
0.0	5.563	6.4	17.5	18.5	29000	0.035
10.0	8	63.8	25.1	202.7	3000	0.056
30.0						

Single Pile Lateral Analysis:

Top Deflection, yt= 0.57200-in
 Max. Moment, M= -26.42-kp-f
 Top Deflection Slope, St= 0.00000
 OK! Top Deflection, 0.5720-in is less than the Allowable Deflection= 1.00-in

Note: If the program cannot find a result or the result exceeds the upper limit. The result will be displayed as 99999.
 The Max. Moment calculated by program is an internal force from the applied load conditions. Structural engineer has to check whether the pile has enough capacity to resist the moment with adequate factor of safety. If not, the pile may fail under the load conditions.



**CivilTech
Software**

**Lot 44
Foundations P1-P8**

Øsummary

ALLPILE 7
LATERAL ANALYSIS SUMMARY OUTPUT
Copyright by CivilTech Software
www.civiltech.com

FACTORS AND CONDITIONS:

Load Factor for Vertical Loads: 1.0
Load Factor for Lateral Loads: 1.0
Loads Supported by Pile Cap: 0 %
Shear Condition: Static

SINGLE PILE:

(with Load Factor)
Vertical Load= 150.00 -kp
Shear= 8.50 -kp
Slope Restrain, St= 0.00 -in/-in

Results:

Top Deflection, yt= 0.57200-in
Max. Moment, M= -26.42-kp-f
Top Deflection Slope, St= 0.00000

Top Deflection, 0.5720-in, OK with the Allowable Deflection= 1.00-in

Note: If the program cannot find a result or the result exceeds the upper limit. The result will be displayed as 99999.

Notes:

- Q - Vertical Load at pile top
- P - Lateral Shear Load at pile top
- M - Moment at pile top
- Xtop - Pile top total settlement
- yt - Pile top deflection
- St - Pile top deflection slope (deflection/unit length)

The Max. Moment calculated by program is an internal moment of shaft due to the loading. Egeineers have to check whether the pile has enough moment capacity to resist the Max. Moment with adequate factor of safety. If not, the pile may be damaged under the loading.

1 1 1 1 1

PILE DEFLECTION & FORCE vs DEPTH

Single Pile, Khead=5, Kbc=2

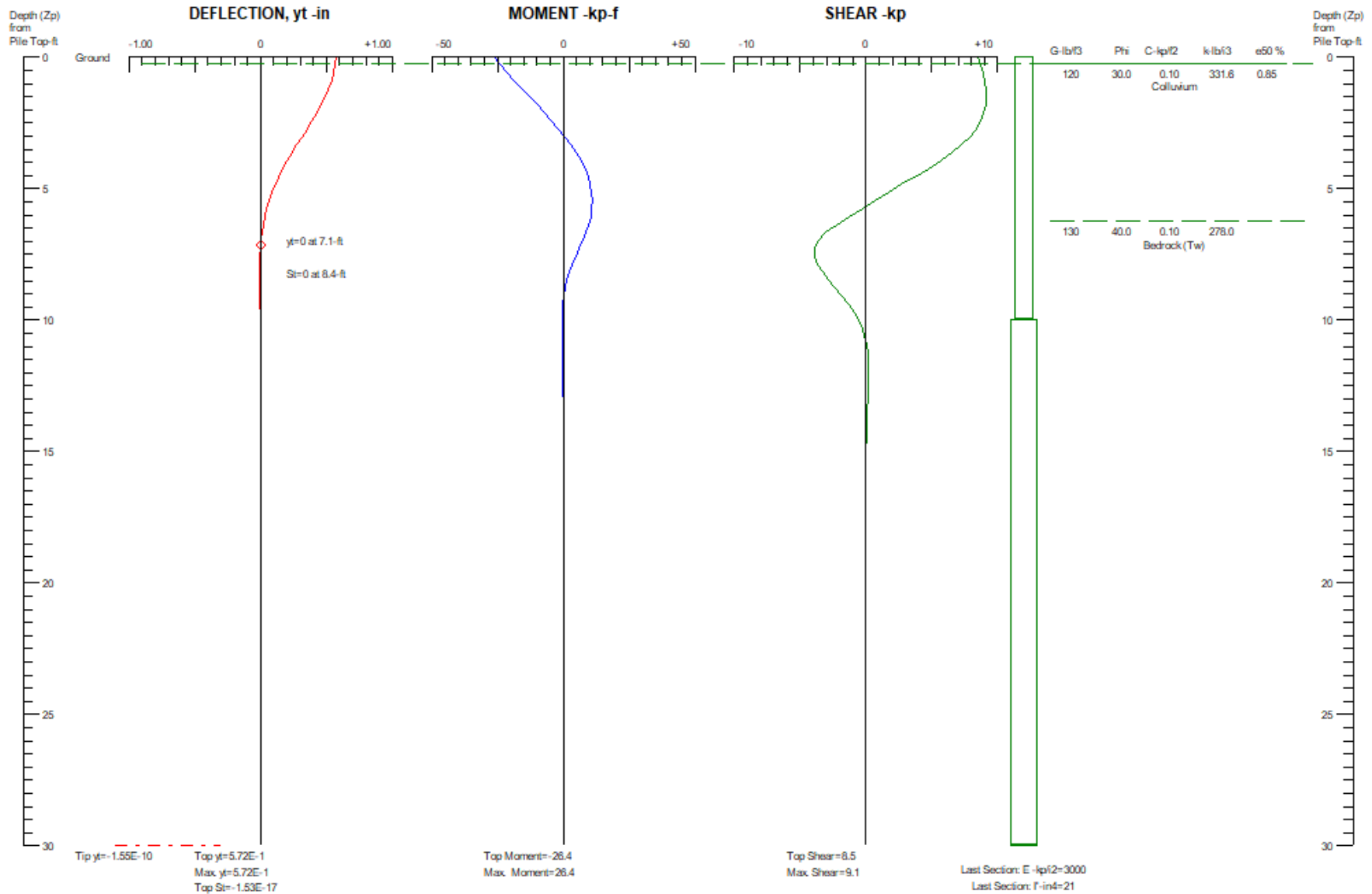

**CivilTech
Software**

**Lot 44
Foundations P1-P8**

Figure 2

ØLoad_L

Depth vs. Deflection, Moment, Shear, and Slope in Single Pile:

Zp -ft	yt -in	Moment -kp-f	Shear -kp	Pressure -kp/f2	Slope
0.0	0.572	-26.4	8.5	0.0	0.00000
0.3	0.568	-23.8	8.7	0.0	-0.00110
0.6	0.557	-21.1	8.9	-0.1	-0.00303
0.9	0.540	-18.3	9.0	-0.2	-0.00467
1.2	0.517	-15.5	9.1	-0.3	-0.00632
1.5	0.490	-12.8	9.1	-0.4	-0.00744
1.8	0.459	-9.9	9.1	-0.4	-0.00852
2.1	0.425	-7.1	9.0	-0.6	-0.00937
2.4	0.389	-4.4	8.7	-0.7	-0.00989
2.7	0.352	-1.8	8.4	-0.9	-0.01016
3.0	0.314	0.6	7.9	-1.1	-0.01047
3.3	0.276	2.9	7.3	-1.3	-0.01044
3.6	0.240	5.0	6.5	-1.5	-0.00989
3.9	0.204	6.8	5.7	-1.6	-0.00992
4.2	0.171	8.3	4.7	-1.7	-0.00907
4.5	0.140	9.4	3.7	-1.7	-0.00852
4.8	0.112	10.3	2.7	-1.6	-0.00771
5.2	0.087	10.8	1.7	-1.6	-0.00687
5.5	0.065	10.9	0.7	-1.5	-0.00601
5.8	0.047	10.8	-0.3	-1.5	-0.00514
6.1	0.031	10.4	-1.3	-1.6	-0.00423
6.4	0.019	9.8	-2.2	-1.5	-0.00339
6.7	0.009	8.8	-3.0	-1.0	-0.00259
7.0	0.003	7.4	-3.6	-0.4	-0.00188
7.3	-0.002	6.1	-3.9	0.2	-0.00128
7.6	-0.005	4.7	-3.9	0.6	-0.00078
7.9	-0.006	3.4	-3.7	0.9	-0.00040
8.2	-0.007	2.3	-3.3	1.0	-0.00012
8.5	-0.007	1.5	-2.8	1.1	0.00007
8.8	-0.006	0.8	-2.3	1.0	0.00019
9.1	-0.005	0.2	-1.8	0.9	0.00025
9.4	-0.004	-0.1	-1.3	0.7	0.00027
9.7	-0.003	-0.4	-0.9	0.5	0.00026
10.0	-0.002	-0.5	-0.6	0.3	0.00023
10.3	-0.001	-0.5	-0.3	0.2	0.00019
10.6	-0.001	-0.5	-0.1	0.2	0.00016
10.9	0.000	-0.5	0.0	0.1	0.00012
11.2	0.000	-0.4	0.1	0.0	0.00009
11.5	0.000	-0.3	0.2	0.0	0.00006
11.8	0.000	-0.2	0.2	0.0	0.00003
12.1	0.000	-0.2	0.2	0.0	0.00002
12.4	0.000	-0.1	0.2	0.0	0.00000
12.7	0.000	-0.1	0.1	0.0	0.00000
13.0	0.000	0.0	0.1	0.0	-0.00001
13.3	0.000	0.0	0.1	0.0	-0.00001
13.6	0.000	0.0	0.1	0.0	-0.00001
13.9	0.000	0.0	0.0	0.0	-0.00001
14.2	0.000	0.0	0.0	0.0	-0.00001
14.5	0.000	0.0	0.0	0.0	-0.00001
14.8	0.000	0.0	0.0	0.0	-0.00001
15.2	0.000	0.0	0.0	0.0	0.00000
15.5	0.000	0.0	0.0	0.0	0.00000
15.8	0.000	0.0	0.0	0.0	0.00000
16.1	0.000	0.0	0.0	0.0	0.00000
16.4	0.000	0.0	0.0	0.0	0.00000
16.7	0.000	0.0	0.0	0.0	0.00000
17.0	0.000	0.0	0.0	0.0	0.00000
17.3	0.000	0.0	0.0	0.0	0.00000

					θLoad_L
17.6	0.000	0.0	0.0	0.0	0.00000
17.9	0.000	0.0	0.0	0.0	0.00000
18.2	0.000	0.0	0.0	0.0	0.00000
18.5	0.000	0.0	0.0	0.0	0.00000
18.8	0.000	0.0	0.0	0.0	0.00000
19.1	0.000	0.0	0.0	0.0	0.00000
19.4	0.000	0.0	0.0	0.0	0.00000
19.7	0.000	0.0	0.0	0.0	0.00000
20.0	0.000	0.0	0.0	0.0	0.00000
20.3	0.000	0.0	0.0	0.0	0.00000
20.6	0.000	0.0	0.0	0.0	0.00000
20.9	0.000	0.0	0.0	0.0	0.00000
21.2	0.000	0.0	0.0	0.0	0.00000
21.5	0.000	0.0	0.0	0.0	0.00000
21.8	0.000	0.0	0.0	0.0	0.00000
22.1	0.000	0.0	0.0	0.0	0.00000
22.4	0.000	0.0	0.0	0.0	0.00000
22.7	0.000	0.0	0.0	0.0	0.00000
23.0	0.000	0.0	0.0	0.0	0.00000
23.3	0.000	0.0	0.0	0.0	0.00000
23.6	0.000	0.0	0.0	0.0	0.00000
23.9	0.000	0.0	0.0	0.0	0.00000
24.2	0.000	0.0	0.0	0.0	0.00000
24.5	0.000	0.0	0.0	0.0	0.00000
24.8	0.000	0.0	0.0	0.0	0.00000
25.2	0.000	0.0	0.0	0.0	0.00000
25.5	0.000	0.0	0.0	0.0	0.00000
25.8	0.000	0.0	0.0	0.0	0.00000
26.1	0.000	0.0	0.0	0.0	0.00000
26.4	0.000	0.0	0.0	0.0	0.00000
26.7	0.000	0.0	0.0	0.0	0.00000
27.0	0.000	0.0	0.0	0.0	0.00000
27.3	0.000	0.0	0.0	0.0	0.00000
27.6	0.000	0.0	0.0	0.0	0.00000
27.9	0.000	0.0	0.0	0.0	0.00000
28.2	0.000	0.0	0.0	0.0	0.00000
28.5	0.000	0.0	0.0	0.0	0.00000
28.8	0.000	0.0	0.0	0.0	0.00000
29.1	0.000	0.0	0.0	0.0	0.00000
29.4	0.000	0.0	0.0	0.0	0.00000
29.7	0.000	0.0	0.0	0.0	0.00000
30.0	0.000	0.0	0.0	0.0	0.00000

Zp - Depth from pile Top
 yt - Pile top deflection
 Moment - Internal moment in pile shaft
 Shear - Internal shear force in pile shaft
 Pressure - Soil-Pile interactive pressure (Arching is considered)
 Slope - Deflection slope at pile top

PILE DEFLECTION vs LOADING Single Pile, Khead=5, Kbc=2

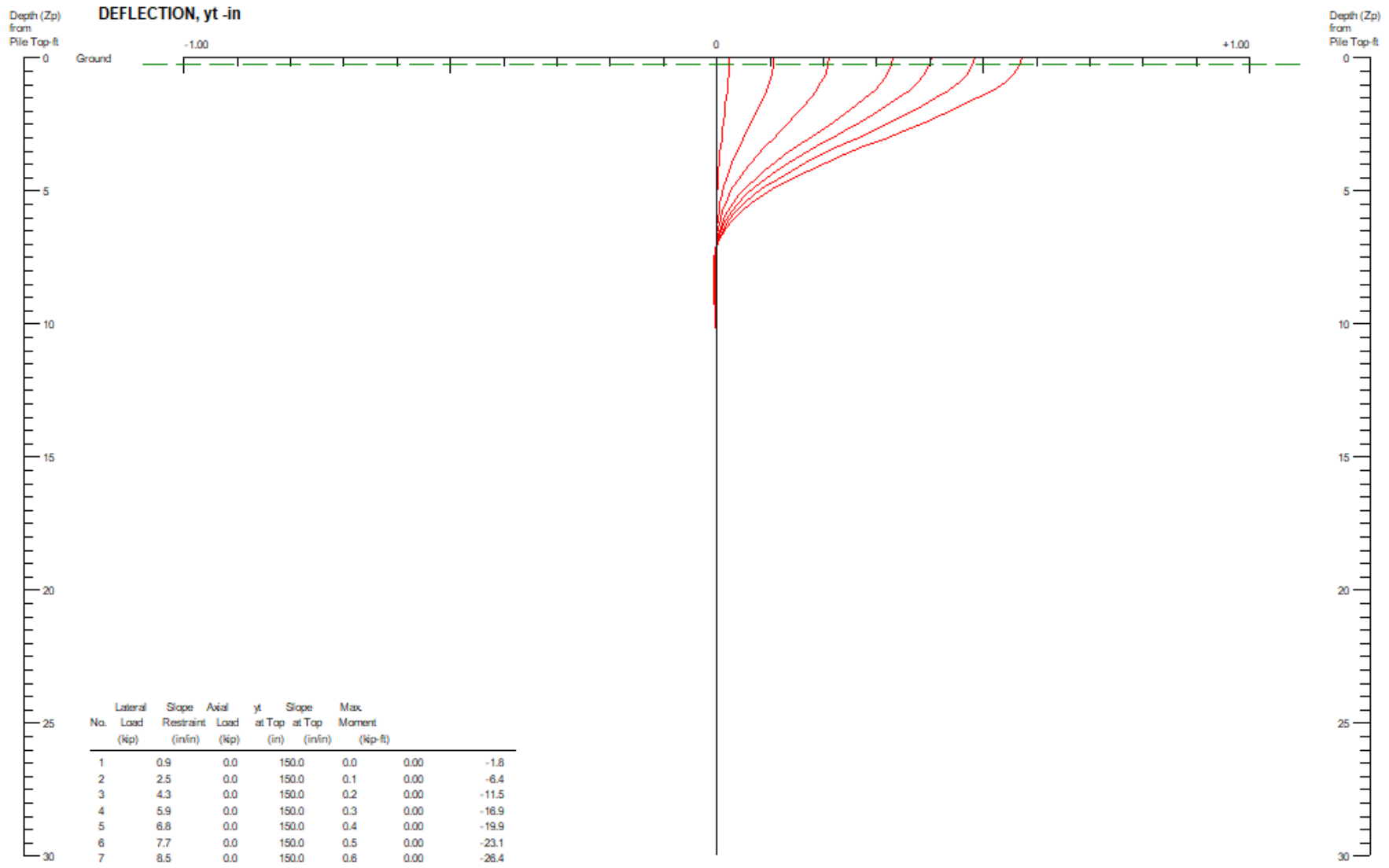

**CivilTech
Software**

**Lot 44
Foundations P1-P8**

Figure 2

PILE MOMENT vs LOADING Single Pile, Khead=5, Kbc=2

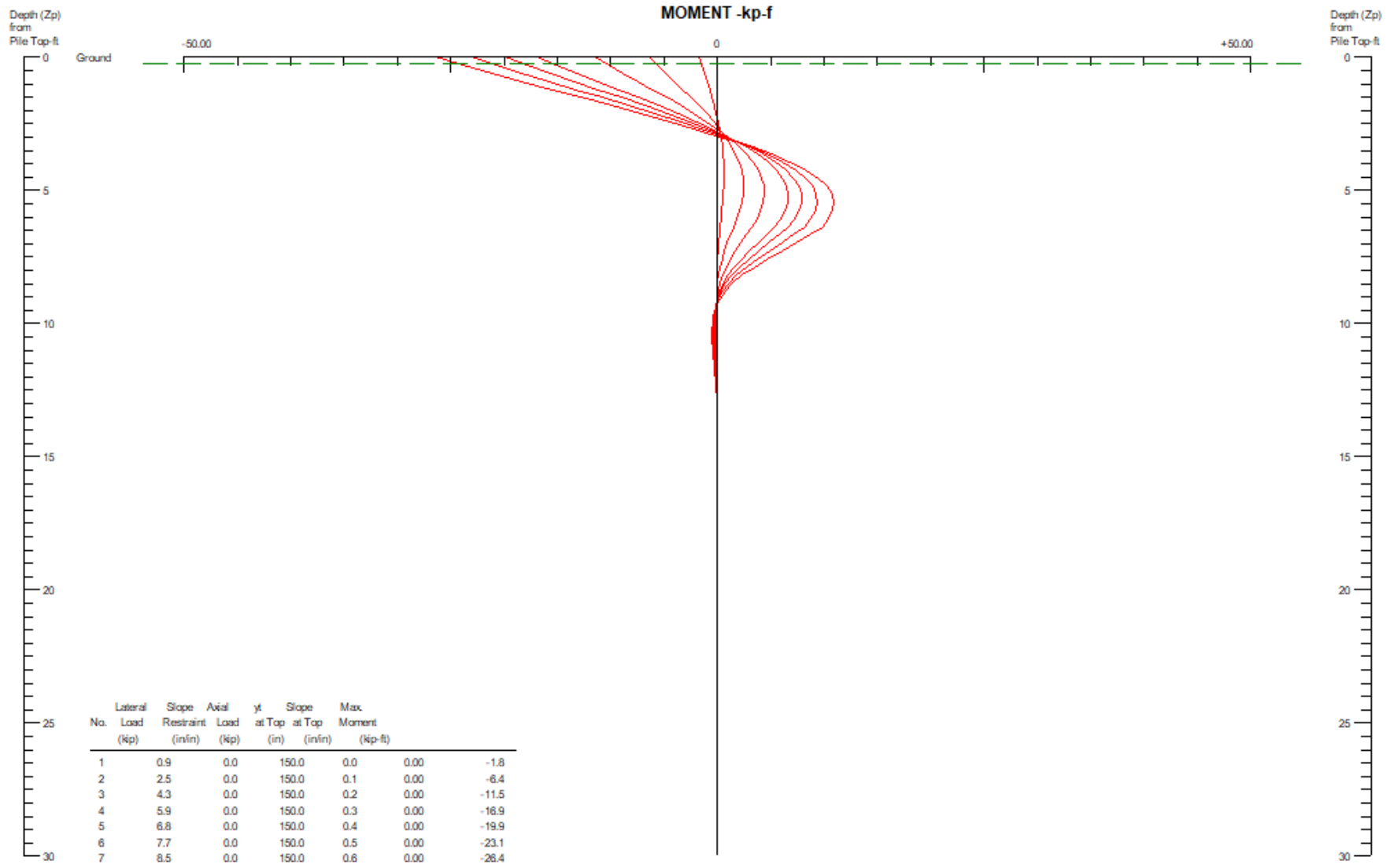

**CivilTech
Software**

**Lot 44
Foundations P1-P8**

Figure 2

LATERAL LOAD vs DEFLECTION & MAX. MOMENT

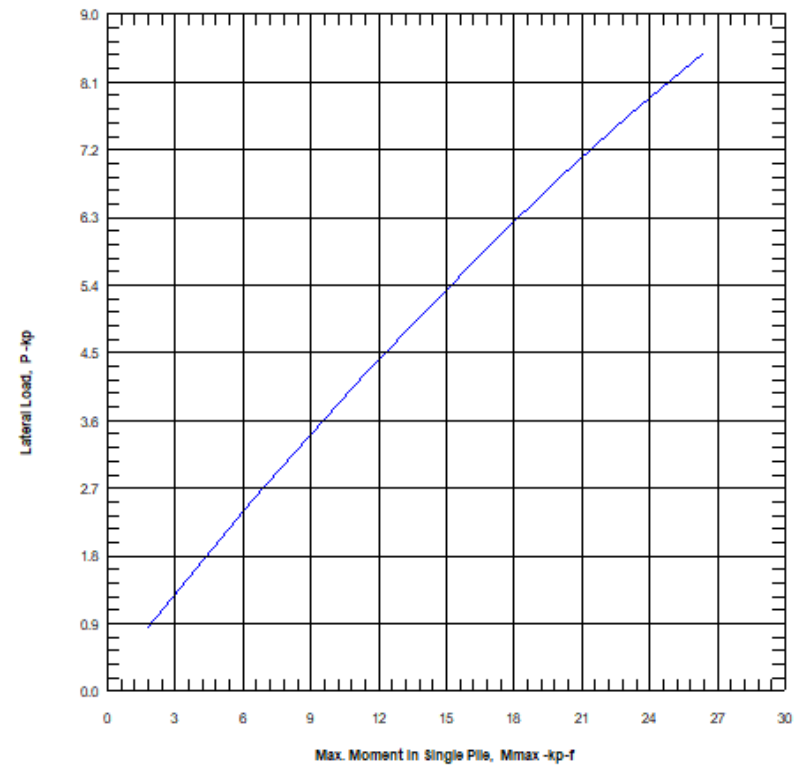
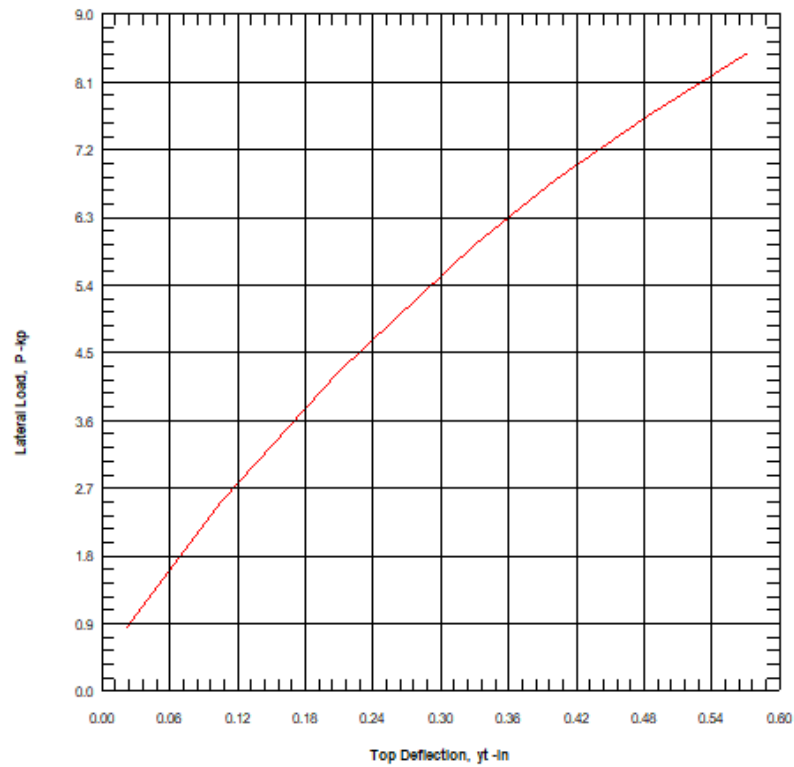

Lateral Load vs Deflection and Max. Moment

P	Q	yt	St	Mmax
-kp	-kp	-in		-kp-f
0.9	150.0	0.02	0.000	-1.8
2.5	150.0	0.11	0.000	-6.4
4.3	150.0	0.21	0.000	-11.5
5.9	150.0	0.33	0.000	-16.9
6.8	150.0	0.40	0.000	-19.9
7.7	150.0	0.48	0.000	-23.1
8.5	150.0	0.57	0.000	-26.4

P - Lateral load at pile top
 Q - Vertical load at pile top
 yt - Lateral deflection at pile top
 St - Deflection slope at pile top
 Mmax - Max. moment in a single pile

Soil Resistance vs. Pile Deflection (p-y)

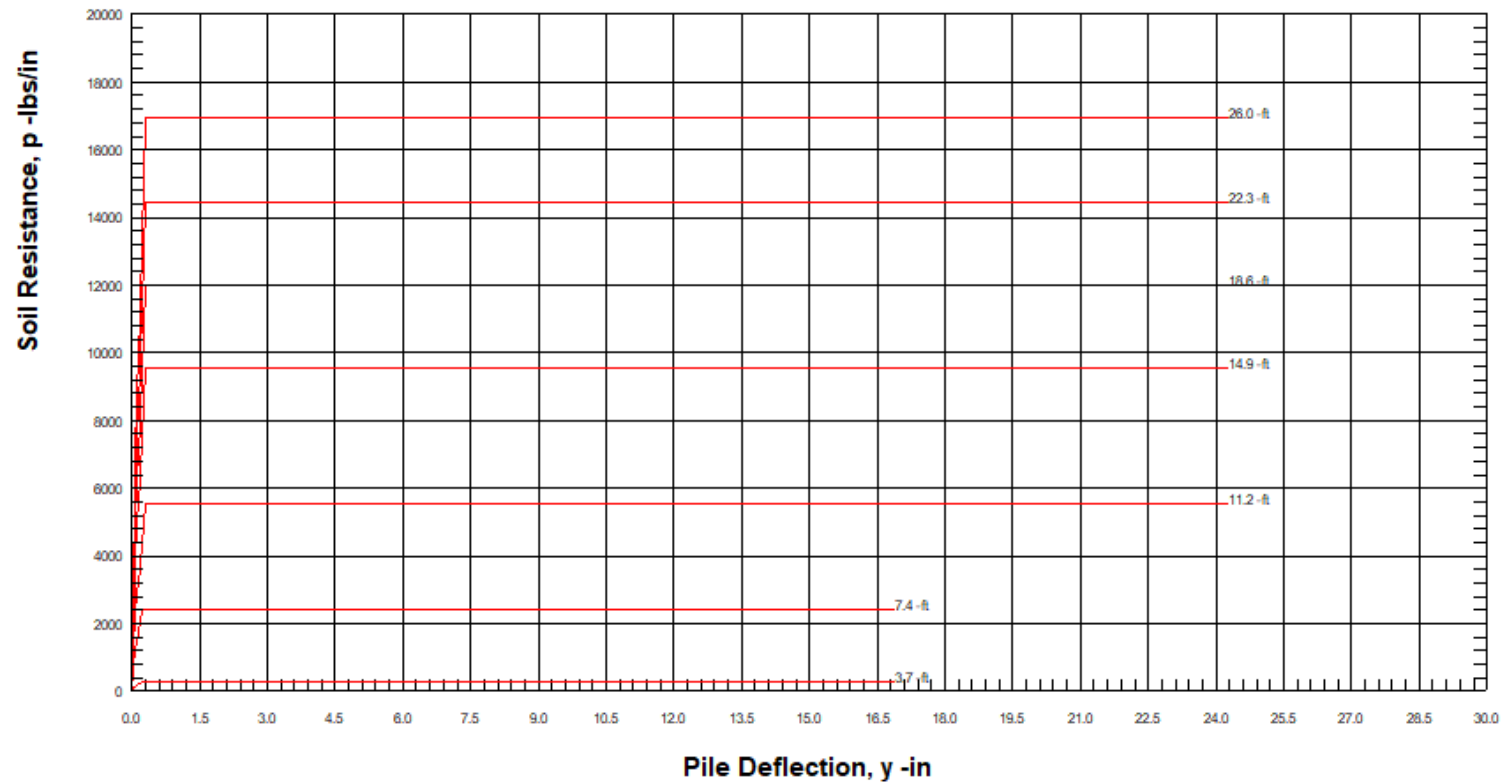

Soil Depth (Zs): 3.7, 7.4, 11.2, 14.9, 18.6, 22.3, 26.0 -ft



Soil Resistance vs. Pile Deflection (p-y)

Zs -ft	p -lbs/in	y -in
3.72	0.0	0.000
3.72	34.2	0.008
3.72	52.1	0.015
3.72	66.7	0.023
3.72	79.5	0.031
3.72	91.0	0.039
3.72	101.7	0.046
3.72	111.7	0.054
3.72	121.1	0.062
3.72	130.1	0.070
3.72	138.7	0.077
3.72	147.0	0.085
3.72	155.0	0.093
3.72	272.8	0.209
3.72	272.8	5.772
3.72	272.8	11.335
3.72	272.8	16.898
7.44	0.0	0.000
7.44	191.8	0.008
7.44	383.6	0.015
7.44	575.4	0.023
7.44	706.5	0.031
7.44	809.1	0.039
7.44	904.0	0.046
7.44	992.8	0.054
7.44	1076.8	0.062
7.44	1156.7	0.070
7.44	1233.2	0.077
7.44	1306.8	0.085
7.44	1377.8	0.093
7.44	2424.9	0.209
7.44	2424.9	5.772
7.44	2424.9	11.335
7.44	2424.9	16.898
11.16	0.0	0.000
11.16	413.6	0.011
11.16	827.2	0.022
11.16	1240.8	0.033
11.16	1619.7	0.044
11.16	1855.0	0.056
11.16	2072.5	0.067
11.16	2276.1	0.078
11.16	2468.6	0.089
11.16	2651.9	0.100
11.16	2827.3	0.111
11.16	2996.0	0.122
11.16	3158.7	0.133
11.16	5559.4	0.300
11.16	5559.4	8.300
11.16	5559.4	16.300
11.16	5559.4	24.300
14.88	0.0	0.000
14.88	551.4	0.011
14.88	1102.7	0.022

ØLoad_L

14.88	1654.1	0.033
14.88	2205.5	0.044
14.88	2756.8	0.056
14.88	3308.2	0.067
14.88	3859.6	0.078
14.88	4236.4	0.089
14.88	4550.9	0.100
14.88	4851.9	0.111
14.88	5141.4	0.122
14.88	5420.7	0.133
14.88	9540.5	0.300
14.88	9540.5	8.300
14.88	9540.5	16.300
14.88	9540.5	24.300
18.59	0.0	0.000
18.59	689.1	0.011
18.59	1378.3	0.022
18.59	2067.4	0.033
18.59	2756.5	0.044
18.59	3445.7	0.056
18.59	4134.8	0.067
18.59	4823.9	0.078
18.59	5328.8	0.089
18.59	5724.4	0.100
18.59	6103.1	0.111
18.59	6467.2	0.122
18.59	6818.5	0.133
18.59	12000.6	0.300
18.59	12000.6	8.300
18.59	12000.6	16.300
18.59	12000.6	24.300
22.31	0.0	0.000
22.31	827.2	0.011
22.31	1654.4	0.022
22.31	2481.6	0.033
22.31	3308.8	0.044
22.31	4136.0	0.056
22.31	4963.2	0.067
22.31	5790.4	0.078
22.31	6423.6	0.089
22.31	6900.5	0.100
22.31	7357.0	0.111
22.31	7795.9	0.122
22.31	8219.5	0.133
22.31	14466.2	0.300
22.31	14466.2	8.300
22.31	14466.2	16.300
22.31	14466.2	24.300
26.03	0.0	0.000
26.03	965.0	0.011
26.03	1929.9	0.022
26.03	2894.9	0.033
26.03	3859.9	0.044
26.03	4824.8	0.056
26.03	5789.8	0.067
26.03	6754.8	0.078
26.03	7516.0	0.089
26.03	8074.0	0.100
26.03	8608.1	0.111
26.03	9121.7	0.122
26.03	9617.2	0.133
26.03	16926.4	0.300
26.03	16926.4	8.300
26.03	16926.4	16.300

26.03	16926.4	24.300	0Load_L
-------	---------	--------	---------

Zs - Depth from Soil Top
p - Soil Resistance
y - Pile Deflection

FOUNDATION PROFILE & SOIL CONDITIONS

For uplift and compression, one no-friction steel casing section and one high pressure grouted section.

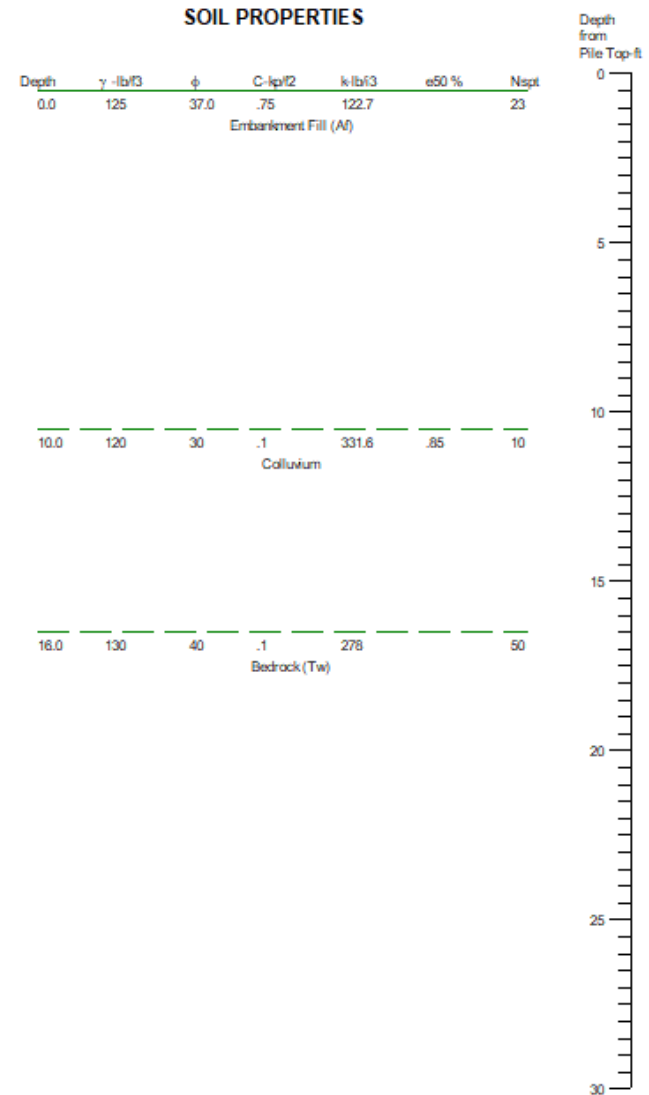
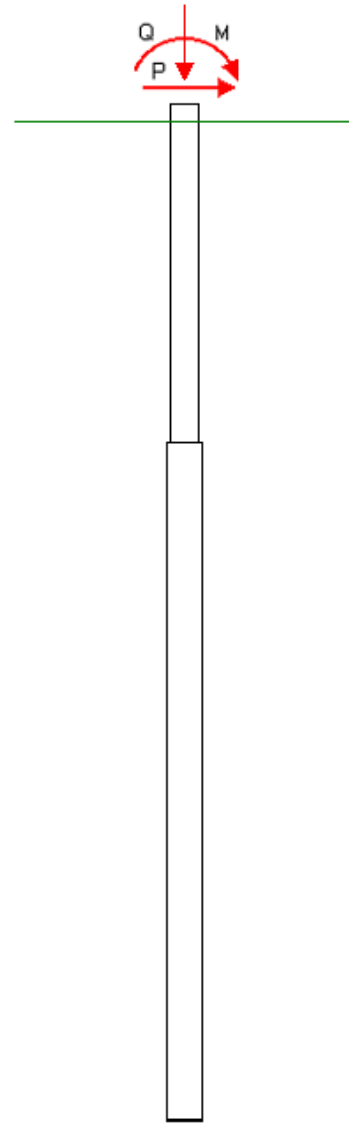
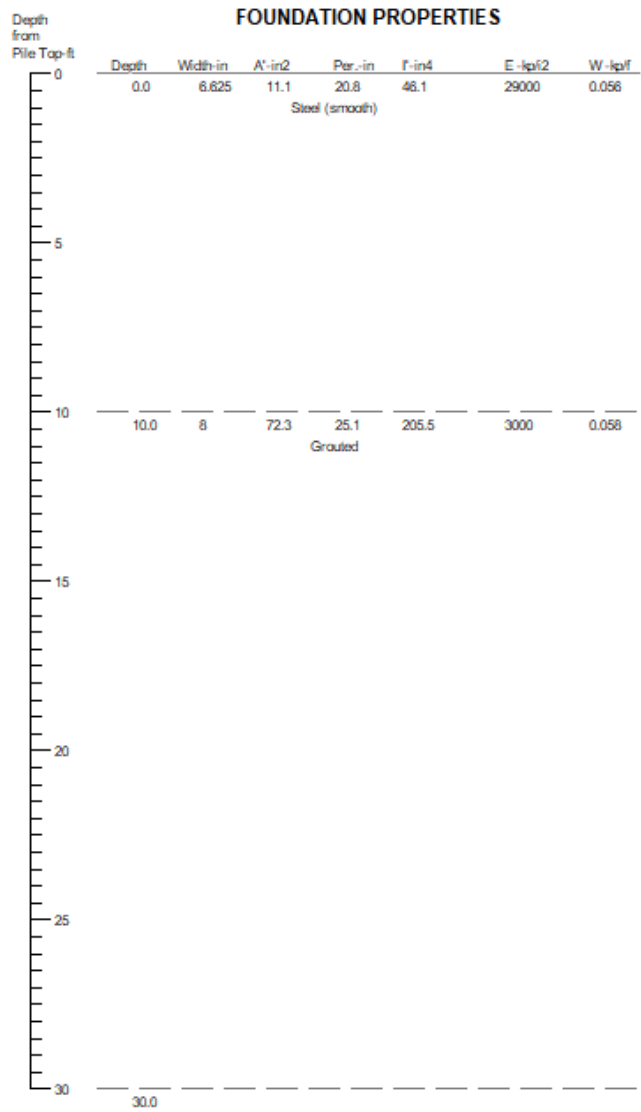

Batter Angle=0

(Pile diameter not to scale)

Surface Angle=0.0



CivilTech Software

Lot 44 Foundations P9 & P10

Figure 1

VERTICAL ANALYSIS

Figure 1

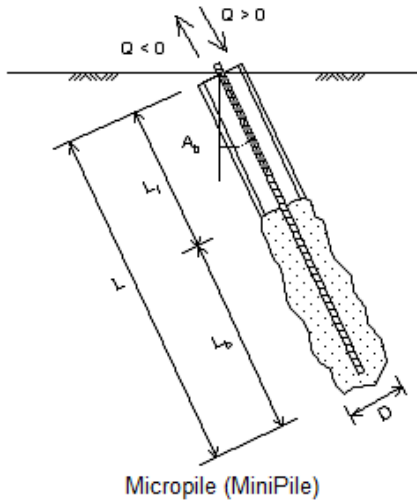

Loads:

Load Factor for Vertical Loads= 1.0
 Load Factor for Lateral Loads= 1.0
 Loads Supported by Pile Cap= 0 %
 Shear Condition: Static

(with Load Factor)

Vertical Load, Q= 100.0 -kp
 Shear Load, P= 14.0 -kp
 Slope Restrain St= 0.00000 -in/in

Profile:

Pile Length, L= 30.0 -ft
 Top Height, H= .5 -ft
 Slope Angle, As= 0.0
 Batter Angle, Ab= 0
 Fixed Head Condition

Soil Data:

Depth -ft	Gamma -lb/f3	Phi	C -kp/f2	K -lb/i3	e50 or Dr %	Nspt
0	125	37.0	.75	122.7	57.53	23
10	120	30	.1	331.6	.85	10
16	130	40	.1	278	85.61	50

Pile Data:

Depth -ft	Width -in	Area -in2	Per. -in	I -in4	E -kp/i2	Weight -kp/f
0.0	6.625	11.1	20.8	46.1	29000	0.056
10.0	8	72.3	25.1	205.5	3000	0.058
30.0						

Vertical Capacity:

Weight above Ground= 0.03 Total Weight= 1.72-kp *Soil Weight is not included
 Side Resistance (Down)= 96.806-kp Side Resistance (Up)= 96.805-kp
 Tip Resistance (Down)= 83.893-kp Tip Resistance (Up)= 0.000-kp
 Total Ultimate Capacity (Down) Qult= 180.699-kp Total Ultimate Capacity (Up)= 98.525-kp
 Total Allowable Capacity (Down) Qallow= 106.484-kp Total Allowable Capacity (Up) Qallow= 50.123-kp
 OK! Qallow > Q

Settlement Calculation:

At Q= 100.00-kp Settlement= 0.09954-in
 At Xallow= 1.00-in Q= 99999.00000-kp

Note: If the program cannot find a result or the result exceeds the upper limit. The result will be displayed as 99999.



**CivilTech
Software**

**Lot 44
Foundations P9 & P10**

Øsummary

ALLPILE 7
VERTICAL ANALYSIS SUMMARY OUTPUT
Copyright by CivilTech Software
www.civiltech.com

TOTAL LOADS:

Vertical Load, Q: 100.0 -kp
Vertical Load with Load Factor, Q: 100.0 -kp
Vertical Load with Load factor and Pile Cap, Q= 100.0 -kp
Load Factor for Vertical Load and Torsion= 1.0
Vertical Loads Supported by Pile Cap: 0 %
Load Factor for Vertical Loads: 1.0

PILE PROFILE:

Pile Length, L= 30.0 -ft
Top Height, H= .5 -ft
Slope Angle, As= 0.0
Batter Angle, Ab= 0.00 Batter Factor, Kbat= 1.00

SINGLE PILE:

Kdown= 1.0 Kup= 1.0 Ka= 0.78

Single Pile Vertical Analysis:

Total Ultimate Capacity (Down)= 180.699-kp Total Ultimate Capacity (Up)= 98.525-kp
Total Allowable Capacity (Down)= 106.484-kp Total Allowable Capacity (Up)= 50.123-kp

Weight above Ground= 0.03 Total Weight= 1.72-kp *Soil Weight is not included
Side Resistance (Down)= 96.806-kp Side Resistance (Up)= 96.805-kp
Tip Resistance (Down)= 83.893-kp Tip Resistance (Up)= 0.000-kp
Negative Friction, Qneg= 0.000-kp, which has been subtracted from Total Ultimate Capacity (Down)
Negative friction does not affect Total Ultimate Capacity (Up)

At Work Load= 100.00-kp, Settlement= 0.09954-in
At Work Load= 100.00-kp, Secant Stiffness Kqx= 1004.60-kp/-in
At Allowable Settlement= 1.000000-in, Capacity= 99999.00-kp
Work Load, 100.00-kp, OK with the Capacity at Allowable Settlement= 1.00000-in, Capacity= 99999.00-kp
Work Load, 100.00-kp, OK with the Allowable Capacity (Down)= 106.48-kp

FACTOR OF SAFETY:

FSSide FStip FSuplif FSweight
1.5 2.0 2.0 1.0

Note: If the program cannot find a result or the result exceeds the upper limit. The result will be displayed as 99999.

1 1 1 1 1

0detail

ALLPILE 7
 VERTICAL ANALYSIS DETAILED OUTPUT
 Copyright by CivilTech Software
 www.civiltech.com

Pile Profile and Loading:

Piletype: Micropile (MiniPile)
 Pile Length, L= 30.0 -ft
 Top Height, H= .5 -ft
 Slope Angle, As= 0.0
 Batter Angle, Ab= 0.00

Single Pile, Vertical Analysis:

Vertical Load with Load factor, Q= 100.0 -kp
 Vertical Load with Load factor and Pile Cap, Q= 100.0 -kp
 Load Factor for Vertical Loads= 1.0
 Vertical Loads Supported by Pile Cap: 0 %
 Kdown= 1.0 Kup= 1.0 Ka= 0.78

Bearing stratum from pile tip extending to 10 Diameter of pile, which is=6.7-ft Starting from Pile Tip= 29.5-ft
 From Ztip=29.5 to 36.2-ft Average Properties: Es= 799.92-kp/f2 C=0.10-kp/f2 Friction=40.00 Cp=0.03 Ksand=1.00
 Limits of Max. tip resistance, q_lim= N/A
 Batter Angle, Ab= 0.00 Batter Factor, Kbat= 1.00
 Qtip_dw=83.9-kp based on qult=240.2-kp/f2 and Base Area=0.3-ft2
 Qtip_up=0.0-kp and Base Area=0.0-ft2

TIP RESISTANCE (Down) CALCULATION:

Tip Depth= 29.5-ft Critical Depth Ratio Z/D= 20 Critical Depth= 13.3-ft
 Equivalent Width of Tip= 0.67-ft, Tip Area= 0.35-ft2 Tip Diameter= 0.67-ft
 Bearing stratum from pile tip extending to 10 Diameter of pile. Bearing stratum= 6.67-ft
 Btip: width at pile tip= 0.67-ft (For group pile, it is equivalent width).
 Phi & C are average value in bearing stratum.
 Batter Angle= 0.00, Batter Factor for Tip and Side= 1.00

Ztip -ft	Z/D	Z_lim -ft	q_lim -kp/f2	Width -ft	Area' -ft2	Phi - o	C -kp/f2	Nq	Nc	Sv -kp/f2	qult -kp/f2	Qtip_dw -kp
29.5	20.0	13.3	N/A	0.67	0.35	40.0	0.10	145.0	9.0	1.7	240.2	83.9

Ztip - Depth of pile tip from ground surface (Zs)
 D - Pile average diameter (below ground) for calculation of critical depth. D=0.67-ft
 Z/D - Critical depth (for tip resistances) as ratio of depth/diameter. Vertical stress will be constant below critical depth
 Z_lim - Critical depth, calculated from Z/D (for tip resistances)
 q_lim - Limit of Maximum tip resistance
 Btip: width or diameter at pile tip
 Bearing stratum: A stratum from pile tip extending to some depth. Average soil properties in the stratum are used for bearing calculation

SIDE RESISTANCE (Uplift & Down) CALCULATION:

D -ft	Z/D	Z_lim -ft	Sf_lim -kp/f2	K_dw	K_up	dz -ft
0.67	20.0	13.33	N/A	1.0	1.0	0.059

D - Pile average diameter for calculation of critical depth
 Z/D - Critical depth (for side resistances) as ratio of depth/diameter. Vertical stress will be constant below critical depth
 Z_lim - Critical depth calculated from Z/D (for side resistances)
 Sf_lim - Limit of Maximum side resistance

SIDE RESISTANCE (Up & Down) CALCULATION vs DEPTH:

Calculation is based on segment dz= 0.06

Zs	Prem	Sv	Phi	Kf(<2)	Delta	f_dw	Ødetail f_up	C	Ka	Kc(<2)	Ca_dw	Ca_up	Sf_dw
Sf_up	Weight	Qneg	Q_dw	Q_up	Torsion	-kp/f2	-kp/f2	-kp/f2		Ca	-kp/f2	-kp/f2	-kp/f2
-ft	-ft	-kp/f2	- o	Delta	- o								
-kp/f2	-kp	-kp	-kp	-kp	-kp-f								
29.50	2.09	1.65	40.0	0.00	0.0	0.00	0.00	0.10	1.16	2000.00	2.00	2.00	0.00
0.00	0.00	0.00	83.9	0.0	0.0								
29.44	2.09	1.65	40.0	0.00	0.0	0.00	0.00	0.10	1.16	2000.00	2.00	2.00	2.00
2.00	0.00	0.00	84.1	0.3	0.1								
29.38	2.09	1.65	40.0	0.00	0.0	0.00	0.00	0.10	1.16	2000.00	2.00	2.00	2.00
2.00	0.01	0.00	84.4	0.5	0.2								
29.32	2.09	1.65	40.0	0.00	0.0	0.00	0.00	0.10	1.16	2000.00	2.00	2.00	2.00
2.00	0.01	0.00	84.6	0.8	0.2								
29.26	2.09	1.65	40.0	0.00	0.0	0.00	0.00	0.10	1.16	2000.00	2.00	2.00	2.00
2.00	0.01	0.00	84.9	1.0	0.3								
29.20	2.09	1.65	40.0	0.00	0.0	0.00	0.00	0.10	1.16	2000.00	2.00	2.00	2.00
2.00	0.02	0.00	85.1	1.3	0.4								
29.15	2.09	1.65	40.0	0.00	0.0	0.00	0.00	0.10	1.16	2000.00	2.00	2.00	2.00
2.00	0.02	0.00	85.4	1.5	0.5								
29.09	2.09	1.65	40.0	0.00	0.0	0.00	0.00	0.10	1.16	2000.00	2.00	2.00	2.00
2.00	0.02	0.00	85.6	1.8	0.6								
29.03	2.09	1.65	40.0	0.00	0.0	0.00	0.00	0.10	1.16	2000.00	2.00	2.00	2.00
2.00	0.03	0.00	85.9	2.0	0.7								
28.97	2.09	1.65	40.0	0.00	0.0	0.00	0.00	0.10	1.16	2000.00	2.00	2.00	2.00
2.00	0.03	0.00	86.1	2.3	0.7								
28.91	2.09	1.65	40.0	0.00	0.0	0.00	0.00	0.10	1.16	2000.00	2.00	2.00	2.00
2.00	0.03	0.00	86.4	2.5	0.8								
28.85	2.09	1.65	40.0	0.00	0.0	0.00	0.00	0.10	1.16	2000.00	2.00	2.00	2.00
2.00	0.04	0.00	86.6	2.8	0.9								
28.79	2.09	1.65	40.0	0.00	0.0	0.00	0.00	0.10	1.16	2000.00	2.00	2.00	2.00
2.00	0.04	0.00	86.9	3.0	1.0								
28.73	2.09	1.65	40.0	0.00	0.0	0.00	0.00	0.10	1.16	2000.00	2.00	2.00	2.00
2.00	0.04	0.00	87.1	3.3	1.1								
28.67	2.09	1.65	40.0	0.00	0.0	0.00	0.00	0.10	1.16	2000.00	2.00	2.00	2.00
2.00	0.05	0.00	87.4	3.5	1.2								
28.61	2.09	1.65	40.0	0.00	0.0	0.00	0.00	0.10	1.16	2000.00	2.00	2.00	2.00
2.00	0.05	0.00	87.6	3.8	1.2								
28.55	2.09	1.65	40.0	0.00	0.0	0.00	0.00	0.10	1.16	2000.00	2.00	2.00	2.00
2.00	0.05	0.00	87.8	4.0	1.3								
28.49	2.09	1.65	40.0	0.00	0.0	0.00	0.00	0.10	1.16	2000.00	2.00	2.00	2.00
2.00	0.06	0.00	88.1	4.3	1.4								
28.44	2.09	1.65	40.0	0.00	0.0	0.00	0.00	0.10	1.16	2000.00	2.00	2.00	2.00
2.00	0.06	0.00	88.3	4.5	1.5								
28.38	2.09	1.65	40.0	0.00	0.0	0.00	0.00	0.10	1.16	2000.00	2.00	2.00	2.00
2.00	0.07	0.00	88.6	4.8	1.6								
28.32	2.09	1.65	40.0	0.00	0.0	0.00	0.00	0.10	1.16	2000.00	2.00	2.00	2.00
2.00	0.07	0.00	88.8	5.0	1.6								
28.26	2.09	1.65	40.0	0.00	0.0	0.00	0.00	0.10	1.16	2000.00	2.00	2.00	2.00
2.00	0.07	0.00	89.1	5.3	1.7								
28.20	2.09	1.65	40.0	0.00	0.0	0.00	0.00	0.10	1.16	2000.00	2.00	2.00	2.00
2.00	0.08	0.00	89.3	5.5	1.8								
28.14	2.09	1.65	40.0	0.00	0.0	0.00	0.00	0.10	1.16	2000.00	2.00	2.00	2.00
2.00	0.08	0.00	89.6	5.8	1.9								
28.08	2.09	1.65	40.0	0.00	0.0	0.00	0.00	0.10	1.16	2000.00	2.00	2.00	2.00
2.00	0.08	0.00	89.8	6.0	2.0								
28.02	2.09	1.65	40.0	0.00	0.0	0.00	0.00	0.10	1.16	2000.00	2.00	2.00	2.00
2.00	0.09	0.00	90.1	6.3	2.1								
27.96	2.09	1.65	40.0	0.00	0.0	0.00	0.00	0.10	1.16	2000.00	2.00	2.00	2.00
2.00	0.09	0.00	90.3	6.5	2.1								
27.90	2.09	1.65	40.0	0.00	0.0	0.00	0.00	0.10	1.16	2000.00	2.00	2.00	2.00
2.00	0.09	0.00	90.6	6.8	2.2								
27.84	2.09	1.65	40.0	0.00	0.0	0.00	0.00	0.10	1.16	2000.00	2.00	2.00	2.00
2.00	0.10	0.00	90.8	7.0	2.3								
27.79	2.09	1.65	40.0	0.00	0.0	0.00	0.00	0.10	1.16	2000.00	2.00	2.00	2.00
2.00	0.10	0.00	91.1	7.3	2.4								
27.73	2.09	1.65	40.0	0.00	0.0	0.00	0.00	0.10	1.16	2000.00	2.00	2.00	2.00

						Ødetail							
2.00	0.10	0.00	91.3	7.5	2.5								
27.67	2.09	1.65	40.0	0.00	0.0	0.00	0.00	0.10	1.16	2000.00	2.00	2.00	2.00
2.00	0.11	0.00	91.6	7.8	2.6								
27.61	2.09	1.65	40.0	0.00	0.0	0.00	0.00	0.10	1.16	2000.00	2.00	2.00	2.00
2.00	0.11	0.00	91.8	8.0	2.6								
27.55	2.09	1.65	40.0	0.00	0.0	0.00	0.00	0.10	1.16	2000.00	2.00	2.00	2.00
2.00	0.11	0.00	92.1	8.3	2.7								
27.49	2.09	1.65	40.0	0.00	0.0	0.00	0.00	0.10	1.16	2000.00	2.00	2.00	2.00
2.00	0.12	0.00	92.3	8.5	2.8								
27.43	2.09	1.65	40.0	0.00	0.0	0.00	0.00	0.10	1.16	2000.00	2.00	2.00	2.00
2.00	0.12	0.00	92.5	8.8	2.9								
27.37	2.09	1.65	40.0	0.00	0.0	0.00	0.00	0.10	1.16	2000.00	2.00	2.00	2.00
2.00	0.12	0.00	92.8	9.0	3.0								
27.31	2.09	1.65	40.0	0.00	0.0	0.00	0.00	0.10	1.16	2000.00	2.00	2.00	2.00
2.00	0.13	0.00	93.0	9.3	3.0								
27.25	2.09	1.65	40.0	0.00	0.0	0.00	0.00	0.10	1.16	2000.00	2.00	2.00	2.00
2.00	0.13	0.00	93.3	9.5	3.1								
27.19	2.09	1.65	40.0	0.00	0.0	0.00	0.00	0.10	1.16	2000.00	2.00	2.00	2.00
2.00	0.13	0.00	93.5	9.8	3.2								
27.14	2.09	1.65	40.0	0.00	0.0	0.00	0.00	0.10	1.16	2000.00	2.00	2.00	2.00
2.00	0.14	0.00	93.8	10.0	3.3								
27.08	2.09	1.65	40.0	0.00	0.0	0.00	0.00	0.10	1.16	2000.00	2.00	2.00	2.00
2.00	0.14	0.00	94.0	10.3	3.4								
27.02	2.09	1.65	40.0	0.00	0.0	0.00	0.00	0.10	1.16	2000.00	2.00	2.00	2.00
2.00	0.14	0.00	94.3	10.5	3.5								
26.96	2.09	1.65	40.0	0.00	0.0	0.00	0.00	0.10	1.16	2000.00	2.00	2.00	2.00
2.00	0.15	0.00	94.5	10.8	3.5								
26.90	2.09	1.65	40.0	0.00	0.0	0.00	0.00	0.10	1.16	2000.00	2.00	2.00	2.00
2.00	0.15	0.00	94.8	11.0	3.6								
26.84	2.09	1.65	40.0	0.00	0.0	0.00	0.00	0.10	1.16	2000.00	2.00	2.00	2.00
2.00	0.15	0.00	95.0	11.3	3.7								
26.78	2.09	1.65	40.0	0.00	0.0	0.00	0.00	0.10	1.16	2000.00	2.00	2.00	2.00
2.00	0.16	0.00	95.3	11.5	3.8								
26.72	2.09	1.65	40.0	0.00	0.0	0.00	0.00	0.10	1.16	2000.00	2.00	2.00	2.00
2.00	0.16	0.00	95.5	11.8	3.9								
26.66	2.09	1.65	40.0	0.00	0.0	0.00	0.00	0.10	1.16	2000.00	2.00	2.00	2.00
2.00	0.16	0.00	95.8	12.0	4.0								
26.60	2.09	1.65	40.0	0.00	0.0	0.00	0.00	0.10	1.16	2000.00	2.00	2.00	2.00
2.00	0.17	0.00	96.0	12.3	4.0								
26.54	2.09	1.65	40.0	0.00	0.0	0.00	0.00	0.10	1.16	2000.00	2.00	2.00	2.00
2.00	0.17	0.00	96.3	12.5	4.1								
26.48	2.09	1.65	40.0	0.00	0.0	0.00	0.00	0.10	1.16	2000.00	2.00	2.00	2.00
2.00	0.17	0.00	96.5	12.8	4.2								
26.43	2.09	1.65	40.0	0.00	0.0	0.00	0.00	0.10	1.16	2000.00	2.00	2.00	2.00
2.00	0.18	0.00	96.8	13.0	4.3								
26.37	2.09	1.65	40.0	0.00	0.0	0.00	0.00	0.10	1.16	2000.00	2.00	2.00	2.00
2.00	0.18	0.00	97.0	13.3	4.4								
26.31	2.09	1.65	40.0	0.00	0.0	0.00	0.00	0.10	1.16	2000.00	2.00	2.00	2.00
2.00	0.19	0.00	97.2	13.5	4.4								
26.25	2.09	1.65	40.0	0.00	0.0	0.00	0.00	0.10	1.16	2000.00	2.00	2.00	2.00
2.00	0.19	0.00	97.5	13.8	4.5								
26.19	2.09	1.65	40.0	0.00	0.0	0.00	0.00	0.10	1.16	2000.00	2.00	2.00	2.00
2.00	0.19	0.00	97.7	14.0	4.6								
26.13	2.09	1.65	40.0	0.00	0.0	0.00	0.00	0.10	1.16	2000.00	2.00	2.00	2.00
2.00	0.20	0.00	98.0	14.3	4.7								
26.07	2.09	1.65	40.0	0.00	0.0	0.00	0.00	0.10	1.16	2000.00	2.00	2.00	2.00
2.00	0.20	0.00	98.2	14.5	4.8								
26.01	2.09	1.65	40.0	0.00	0.0	0.00	0.00	0.10	1.16	2000.00	2.00	2.00	2.00
2.00	0.20	0.00	98.5	14.8	4.9								
25.95	2.09	1.65	40.0	0.00	0.0	0.00	0.00	0.10	1.16	2000.00	2.00	2.00	2.00
2.00	0.21	0.00	98.7	15.0	4.9								
25.89	2.09	1.65	40.0	0.00	0.0	0.00	0.00	0.10	1.16	2000.00	2.00	2.00	2.00
2.00	0.21	0.00	99.0	15.3	5.0								
25.83	2.09	1.65	40.0	0.00	0.0	0.00	0.00	0.10	1.16	2000.00	2.00	2.00	2.00
2.00	0.21	0.00	99.2	15.5	5.1								
25.78	2.09	1.65	40.0	0.00	0.0	0.00	0.00	0.10	1.16	2000.00	2.00	2.00	2.00
2.00	0.22	0.00	99.5	15.8	5.2								

													0detail
25.72	2.09	1.65	40.0	0.00	0.0	0.00	0.00	0.10	1.16	2000.00	2.00	2.00	2.00
2.00	0.22	0.00	99.7	16.0	5.3								
25.66	2.09	1.65	40.0	0.00	0.0	0.00	0.00	0.10	1.16	2000.00	2.00	2.00	2.00
2.00	0.22	0.00	100.0	16.3	5.4								
25.60	2.09	1.65	40.0	0.00	0.0	0.00	0.00	0.10	1.16	2000.00	2.00	2.00	2.00
2.00	0.23	0.00	100.2	16.5	5.4								
25.54	2.09	1.65	40.0	0.00	0.0	0.00	0.00	0.10	1.16	2000.00	2.00	2.00	2.00
2.00	0.23	0.00	100.5	16.8	5.5								
25.48	2.09	1.65	40.0	0.00	0.0	0.00	0.00	0.10	1.16	2000.00	2.00	2.00	2.00
2.00	0.23	0.00	100.7	17.1	5.6								
25.42	2.09	1.65	40.0	0.00	0.0	0.00	0.00	0.10	1.16	2000.00	2.00	2.00	2.00
2.00	0.24	0.00	101.0	17.3	5.7								
25.36	2.09	1.65	40.0	0.00	0.0	0.00	0.00	0.10	1.16	2000.00	2.00	2.00	2.00
2.00	0.24	0.00	101.2	17.6	5.8								
25.30	2.09	1.65	40.0	0.00	0.0	0.00	0.00	0.10	1.16	2000.00	2.00	2.00	2.00
2.00	0.24	0.00	101.5	17.8	5.8								
25.24	2.09	1.65	40.0	0.00	0.0	0.00	0.00	0.10	1.16	2000.00	2.00	2.00	2.00
2.00	0.25	0.00	101.7	18.1	5.9								
25.18	2.09	1.65	40.0	0.00	0.0	0.00	0.00	0.10	1.16	2000.00	2.00	2.00	2.00
2.00	0.25	0.00	101.9	18.3	6.0								
25.13	2.09	1.65	40.0	0.00	0.0	0.00	0.00	0.10	1.16	2000.00	2.00	2.00	2.00
2.00	0.25	0.00	102.2	18.6	6.1								
25.07	2.09	1.65	40.0	0.00	0.0	0.00	0.00	0.10	1.16	2000.00	2.00	2.00	2.00
2.00	0.26	0.00	102.4	18.8	6.2								
25.01	2.09	1.65	40.0	0.00	0.0	0.00	0.00	0.10	1.16	2000.00	2.00	2.00	2.00
2.00	0.26	0.00	102.7	19.1	6.3								
24.95	2.09	1.65	40.0	0.00	0.0	0.00	0.00	0.10	1.16	2000.00	2.00	2.00	2.00
2.00	0.26	0.00	102.9	19.3	6.3								
24.89	2.09	1.65	40.0	0.00	0.0	0.00	0.00	0.10	1.16	2000.00	2.00	2.00	2.00
2.00	0.27	0.00	103.2	19.6	6.4								
24.83	2.09	1.65	40.0	0.00	0.0	0.00	0.00	0.10	1.16	2000.00	2.00	2.00	2.00
2.00	0.27	0.00	103.4	19.8	6.5								
24.77	2.09	1.65	40.0	0.00	0.0	0.00	0.00	0.10	1.16	2000.00	2.00	2.00	2.00
2.00	0.27	0.00	103.7	20.1	6.6								
24.71	2.09	1.65	40.0	0.00	0.0	0.00	0.00	0.10	1.16	2000.00	2.00	2.00	2.00
2.00	0.28	0.00	103.9	20.3	6.7								
24.65	2.09	1.65	40.0	0.00	0.0	0.00	0.00	0.10	1.16	2000.00	2.00	2.00	2.00
2.00	0.28	0.00	104.2	20.6	6.8								
24.59	2.09	1.65	40.0	0.00	0.0	0.00	0.00	0.10	1.16	2000.00	2.00	2.00	2.00
2.00	0.28	0.00	104.4	20.8	6.8								
24.53	2.09	1.65	40.0	0.00	0.0	0.00	0.00	0.10	1.16	2000.00	2.00	2.00	2.00
2.00	0.29	0.00	104.7	21.1	6.9								
24.47	2.09	1.65	40.0	0.00	0.0	0.00	0.00	0.10	1.16	2000.00	2.00	2.00	2.00
2.00	0.29	0.00	104.9	21.3	7.0								
24.42	2.09	1.65	40.0	0.00	0.0	0.00	0.00	0.10	1.16	2000.00	2.00	2.00	2.00
2.00	0.29	0.00	105.2	21.6	7.1								
24.36	2.09	1.65	40.0	0.00	0.0	0.00	0.00	0.10	1.16	2000.00	2.00	2.00	2.00
2.00	0.30	0.00	105.4	21.8	7.2								
24.30	2.09	1.65	40.0	0.00	0.0	0.00	0.00	0.10	1.16	2000.00	2.00	2.00	2.00
2.00	0.30	0.00	105.7	22.1	7.2								
24.24	2.09	1.65	40.0	0.00	0.0	0.00	0.00	0.10	1.16	2000.00	2.00	2.00	2.00
2.00	0.31	0.00	105.9	22.3	7.3								
24.18	2.09	1.65	40.0	0.00	0.0	0.00	0.00	0.10	1.16	2000.00	2.00	2.00	2.00
2.00	0.31	0.00	106.2	22.6	7.4								
24.12	2.09	1.65	40.0	0.00	0.0	0.00	0.00	0.10	1.16	2000.00	2.00	2.00	2.00
2.00	0.31	0.00	106.4	22.8	7.5								
24.06	2.09	1.65	40.0	0.00	0.0	0.00	0.00	0.10	1.16	2000.00	2.00	2.00	2.00
2.00	0.32	0.00	106.6	23.1	7.6								
24.00	2.09	1.65	40.0	0.00	0.0	0.00	0.00	0.10	1.16	2000.00	2.00	2.00	2.00
2.00	0.32	0.00	106.9	23.3	7.7								
23.94	2.09	1.65	40.0	0.00	0.0	0.00	0.00	0.10	1.16	2000.00	2.00	2.00	2.00
2.00	0.32	0.00	107.1	23.6	7.7								
23.88	2.09	1.65	40.0	0.00	0.0	0.00	0.00	0.10	1.16	2000.00	2.00	2.00	2.00
2.00	0.33	0.00	107.4	23.8	7.8								
23.82	2.09	1.65	40.0	0.00	0.0	0.00	0.00	0.10	1.16	2000.00	2.00	2.00	2.00
2.00	0.33	0.00	107.6	24.1	7.9								
23.77	2.09	1.65	40.0	0.00	0.0	0.00	0.00	0.10	1.16	2000.00	2.00	2.00	2.00

Ødetail

2.00	0.33	0.00	107.9	24.3	8.0								
23.71	2.09	1.65	40.0	0.00	0.0	0.00	0.00	0.10	1.16	2000.00	2.00	2.00	2.00
2.00	0.34	0.00	108.1	24.6	8.1								
23.65	2.09	1.65	40.0	0.00	0.0	0.00	0.00	0.10	1.16	2000.00	2.00	2.00	2.00
2.00	0.34	0.00	108.4	24.8	8.2								
23.59	2.09	1.65	40.0	0.00	0.0	0.00	0.00	0.10	1.16	2000.00	2.00	2.00	2.00
2.00	0.34	0.00	108.6	25.1	8.2								
23.53	2.09	1.65	40.0	0.00	0.0	0.00	0.00	0.10	1.16	2000.00	2.00	2.00	2.00
2.00	0.35	0.00	108.9	25.3	8.3								
23.47	2.09	1.65	40.0	0.00	0.0	0.00	0.00	0.10	1.16	2000.00	2.00	2.00	2.00
2.00	0.35	0.00	109.1	25.6	8.4								
23.41	2.09	1.65	40.0	0.00	0.0	0.00	0.00	0.10	1.16	2000.00	2.00	2.00	2.00
2.00	0.35	0.00	109.4	25.8	8.5								
23.35	2.09	1.65	40.0	0.00	0.0	0.00	0.00	0.10	1.16	2000.00	2.00	2.00	2.00
2.00	0.36	0.00	109.6	26.1	8.6								
23.29	2.09	1.65	40.0	0.00	0.0	0.00	0.00	0.10	1.16	2000.00	2.00	2.00	2.00
2.00	0.36	0.00	109.9	26.3	8.6								
23.23	2.09	1.65	40.0	0.00	0.0	0.00	0.00	0.10	1.16	2000.00	2.00	2.00	2.00
2.00	0.36	0.00	110.1	26.6	8.7								
23.17	2.09	1.65	40.0	0.00	0.0	0.00	0.00	0.10	1.16	2000.00	2.00	2.00	2.00
2.00	0.37	0.00	110.4	26.8	8.8								
23.12	2.09	1.65	40.0	0.00	0.0	0.00	0.00	0.10	1.16	2000.00	2.00	2.00	2.00
2.00	0.37	0.00	110.6	27.1	8.9								
23.06	2.09	1.65	40.0	0.00	0.0	0.00	0.00	0.10	1.16	2000.00	2.00	2.00	2.00
2.00	0.37	0.00	110.8	27.3	9.0								
23.00	2.09	1.65	40.0	0.00	0.0	0.00	0.00	0.10	1.16	2000.00	2.00	2.00	2.00
2.00	0.38	0.00	111.1	27.6	9.1								
22.94	2.09	1.65	40.0	0.00	0.0	0.00	0.00	0.10	1.16	2000.00	2.00	2.00	2.00
2.00	0.38	0.00	111.3	27.8	9.1								
22.88	2.09	1.65	40.0	0.00	0.0	0.00	0.00	0.10	1.16	2000.00	2.00	2.00	2.00
2.00	0.38	0.00	111.6	28.1	9.2								
22.82	2.09	1.65	40.0	0.00	0.0	0.00	0.00	0.10	1.16	2000.00	2.00	2.00	2.00
2.00	0.39	0.00	111.8	28.3	9.3								
22.76	2.09	1.65	40.0	0.00	0.0	0.00	0.00	0.10	1.16	2000.00	2.00	2.00	2.00
2.00	0.39	0.00	112.1	28.6	9.4								
22.70	2.09	1.65	40.0	0.00	0.0	0.00	0.00	0.10	1.16	2000.00	2.00	2.00	2.00
2.00	0.39	0.00	112.3	28.8	9.5								
22.64	2.09	1.65	40.0	0.00	0.0	0.00	0.00	0.10	1.16	2000.00	2.00	2.00	2.00
2.00	0.40	0.00	112.6	29.1	9.6								
22.58	2.09	1.65	40.0	0.00	0.0	0.00	0.00	0.10	1.16	2000.00	2.00	2.00	2.00
2.00	0.40	0.00	112.8	29.3	9.6								
22.52	2.09	1.65	40.0	0.00	0.0	0.00	0.00	0.10	1.16	2000.00	2.00	2.00	2.00
2.00	0.40	0.00	113.1	29.6	9.7								
22.46	2.09	1.65	40.0	0.00	0.0	0.00	0.00	0.10	1.16	2000.00	2.00	2.00	2.00
2.00	0.41	0.00	113.3	29.8	9.8								
22.41	2.09	1.65	40.0	0.00	0.0	0.00	0.00	0.10	1.16	2000.00	2.00	2.00	2.00
2.00	0.41	0.00	113.6	30.1	9.9								
22.35	2.09	1.65	40.0	0.00	0.0	0.00	0.00	0.10	1.16	2000.00	2.00	2.00	2.00
2.00	0.41	0.00	113.8	30.3	10.0								
22.29	2.09	1.65	40.0	0.00	0.0	0.00	0.00	0.10	1.16	2000.00	2.00	2.00	2.00
2.00	0.42	0.00	114.1	30.6	10.0								
22.23	2.09	1.65	40.0	0.00	0.0	0.00	0.00	0.10	1.16	2000.00	2.00	2.00	2.00
2.00	0.42	0.00	114.3	30.8	10.1								
22.17	2.09	1.65	40.0	0.00	0.0	0.00	0.00	0.10	1.16	2000.00	2.00	2.00	2.00
2.00	0.43	0.00	114.6	31.1	10.2								
22.11	2.09	1.65	40.0	0.00	0.0	0.00	0.00	0.10	1.16	2000.00	2.00	2.00	2.00
2.00	0.43	0.00	114.8	31.3	10.3								
22.05	2.09	1.65	40.0	0.00	0.0	0.00	0.00	0.10	1.16	2000.00	2.00	2.00	2.00
2.00	0.43	0.00	115.1	31.6	10.4								
21.99	2.09	1.65	40.0	0.00	0.0	0.00	0.00	0.10	1.16	2000.00	2.00	2.00	2.00
2.00	0.44	0.00	115.3	31.8	10.5								
21.93	2.09	1.65	40.0	0.00	0.0	0.00	0.00	0.10	1.16	2000.00	2.00	2.00	2.00
2.00	0.44	0.00	115.5	32.1	10.5								
21.87	2.09	1.65	40.0	0.00	0.0	0.00	0.00	0.10	1.16	2000.00	2.00	2.00	2.00
2.00	0.44	0.00	115.8	32.3	10.6								
21.81	2.09	1.65	40.0	0.00	0.0	0.00	0.00	0.10	1.16	2000.00	2.00	2.00	2.00
2.00	0.45	0.00	116.0	32.6	10.7								

													0detail
21.76	2.09	1.65	40.0	0.00	0.0	0.00	0.00	0.10	1.16	2000.00	2.00	2.00	2.00
2.00	0.45	0.00	116.3	32.8	10.8								
21.70	2.09	1.65	40.0	0.00	0.0	0.00	0.00	0.10	1.16	2000.00	2.00	2.00	2.00
2.00	0.45	0.00	116.5	33.1	10.9								
21.64	2.09	1.65	40.0	0.00	0.0	0.00	0.00	0.10	1.16	2000.00	2.00	2.00	2.00
2.00	0.46	0.00	116.8	33.3	10.9								
21.58	2.09	1.65	40.0	0.00	0.0	0.00	0.00	0.10	1.16	2000.00	2.00	2.00	2.00
2.00	0.46	0.00	117.0	33.6	11.0								
21.52	2.09	1.65	40.0	0.00	0.0	0.00	0.00	0.10	1.16	2000.00	2.00	2.00	2.00
2.00	0.46	0.00	117.3	33.8	11.1								
21.46	2.09	1.65	40.0	0.00	0.0	0.00	0.00	0.10	1.16	2000.00	2.00	2.00	2.00
2.00	0.47	0.00	117.5	34.1	11.2								
21.40	2.09	1.65	40.0	0.00	0.0	0.00	0.00	0.10	1.16	2000.00	2.00	2.00	2.00
2.00	0.47	0.00	117.8	34.4	11.3								
21.34	2.09	1.65	40.0	0.00	0.0	0.00	0.00	0.10	1.16	2000.00	2.00	2.00	2.00
2.00	0.47	0.00	118.0	34.6	11.4								
21.28	2.09	1.65	40.0	0.00	0.0	0.00	0.00	0.10	1.16	2000.00	2.00	2.00	2.00
2.00	0.48	0.00	118.3	34.9	11.4								
21.22	2.09	1.65	40.0	0.00	0.0	0.00	0.00	0.10	1.16	2000.00	2.00	2.00	2.00
2.00	0.48	0.00	118.5	35.1	11.5								
21.16	2.09	1.65	40.0	0.00	0.0	0.00	0.00	0.10	1.16	2000.00	2.00	2.00	2.00
2.00	0.48	0.00	118.8	35.4	11.6								
21.11	2.09	1.65	40.0	0.00	0.0	0.00	0.00	0.10	1.16	2000.00	2.00	2.00	2.00
2.00	0.49	0.00	119.0	35.6	11.7								
21.05	2.09	1.65	40.0	0.00	0.0	0.00	0.00	0.10	1.16	2000.00	2.00	2.00	2.00
2.00	0.49	0.00	119.3	35.9	11.8								
20.99	2.09	1.65	40.0	0.00	0.0	0.00	0.00	0.10	1.16	2000.00	2.00	2.00	2.00
2.00	0.49	0.00	119.5	36.1	11.9								
20.93	2.09	1.65	40.0	0.00	0.0	0.00	0.00	0.10	1.16	2000.00	2.00	2.00	2.00
2.00	0.50	0.00	119.8	36.4	11.9								
20.87	2.09	1.65	40.0	0.00	0.0	0.00	0.00	0.10	1.16	2000.00	2.00	2.00	2.00
2.00	0.50	0.00	120.0	36.6	12.0								
20.81	2.09	1.65	40.0	0.00	0.0	0.00	0.00	0.10	1.16	2000.00	2.00	2.00	2.00
2.00	0.50	0.00	120.2	36.9	12.1								
20.75	2.09	1.65	40.0	0.00	0.0	0.00	0.00	0.10	1.16	2000.00	2.00	2.00	2.00
2.00	0.51	0.00	120.5	37.1	12.2								
20.69	2.09	1.65	40.0	0.00	0.0	0.00	0.00	0.10	1.16	2000.00	2.00	2.00	2.00
2.00	0.51	0.00	120.7	37.4	12.3								
20.63	2.09	1.65	40.0	0.00	0.0	0.00	0.00	0.10	1.16	2000.00	2.00	2.00	2.00
2.00	0.51	0.00	121.0	37.6	12.3								
20.57	2.09	1.65	40.0	0.00	0.0	0.00	0.00	0.10	1.16	2000.00	2.00	2.00	2.00
2.00	0.52	0.00	121.2	37.9	12.4								
20.51	2.09	1.65	40.0	0.00	0.0	0.00	0.00	0.10	1.16	2000.00	2.00	2.00	2.00
2.00	0.52	0.00	121.5	38.1	12.5								
20.45	2.09	1.65	40.0	0.00	0.0	0.00	0.00	0.10	1.16	2000.00	2.00	2.00	2.00
2.00	0.52	0.00	121.7	38.4	12.6								
20.40	2.09	1.65	40.0	0.00	0.0	0.00	0.00	0.10	1.16	2000.00	2.00	2.00	2.00
2.00	0.53	0.00	122.0	38.6	12.7								
20.34	2.09	1.65	40.0	0.00	0.0	0.00	0.00	0.10	1.16	2000.00	2.00	2.00	2.00
2.00	0.53	0.00	122.2	38.9	12.8								
20.28	2.09	1.65	40.0	0.00	0.0	0.00	0.00	0.10	1.16	2000.00	2.00	2.00	2.00
2.00	0.53	0.00	122.5	39.1	12.8								
20.22	2.09	1.65	40.0	0.00	0.0	0.00	0.00	0.10	1.16	2000.00	2.00	2.00	2.00
2.00	0.54	0.00	122.7	39.4	12.9								
20.16	2.09	1.65	40.0	0.00	0.0	0.00	0.00	0.10	1.16	2000.00	2.00	2.00	2.00
2.00	0.54	0.00	123.0	39.6	13.0								
20.10	2.09	1.65	40.0	0.00	0.0	0.00	0.00	0.10	1.16	2000.00	2.00	2.00	2.00
2.00	0.55	0.00	123.2	39.9	13.1								
20.04	2.09	1.65	40.0	0.00	0.0	0.00	0.00	0.10	1.16	2000.00	2.00	2.00	2.00
2.00	0.55	0.00	123.5	40.1	13.2								
19.98	2.09	1.65	40.0	0.00	0.0	0.00	0.00	0.10	1.16	2000.00	2.00	2.00	2.00
2.00	0.55	0.00	123.7	40.4	13.3								
19.92	2.09	1.65	40.0	0.00	0.0	0.00	0.00	0.10	1.16	2000.00	2.00	2.00	2.00
2.00	0.56	0.00	124.0	40.6	13.3								
19.86	2.09	1.65	40.0	0.00	0.0	0.00	0.00	0.10	1.16	2000.00	2.00	2.00	2.00
2.00	0.56	0.00	124.2	40.9	13.4								
19.80	2.09	1.65	40.0	0.00	0.0	0.00	0.00	0.10	1.16	2000.00	2.00	2.00	2.00

0detail

2.00	0.56	0.00	124.5	41.1	13.5								
19.75	2.09	1.65	40.0	0.00	0.0	0.00	0.00	0.10	1.16	2000.00	2.00	2.00	2.00
2.00	0.57	0.00	124.7	41.4	13.6								
19.69	2.09	1.65	40.0	0.00	0.0	0.00	0.00	0.10	1.16	2000.00	2.00	2.00	2.00
2.00	0.57	0.00	124.9	41.6	13.7								
19.63	2.09	1.65	40.0	0.00	0.0	0.00	0.00	0.10	1.16	2000.00	2.00	2.00	2.00
2.00	0.57	0.00	125.2	41.9	13.7								
19.57	2.09	1.65	40.0	0.00	0.0	0.00	0.00	0.10	1.16	2000.00	2.00	2.00	2.00
2.00	0.58	0.00	125.4	42.1	13.8								
19.51	2.09	1.65	40.0	0.00	0.0	0.00	0.00	0.10	1.16	2000.00	2.00	2.00	2.00
2.00	0.58	0.00	125.7	42.4	13.9								
19.45	2.09	1.65	40.0	0.00	0.0	0.00	0.00	0.10	1.16	2000.00	2.00	2.00	2.00
2.00	0.58	0.00	125.9	42.6	14.0								
19.39	2.09	1.65	40.0	0.00	0.0	0.00	0.00	0.10	1.16	2000.00	2.00	2.00	2.00
2.00	0.59	0.00	126.2	42.9	14.1								
19.33	2.09	1.65	40.0	0.00	0.0	0.00	0.00	0.10	1.16	2000.00	2.00	2.00	2.00
2.00	0.59	0.00	126.4	43.1	14.2								
19.27	2.09	1.65	40.0	0.00	0.0	0.00	0.00	0.10	1.16	2000.00	2.00	2.00	2.00
2.00	0.59	0.00	126.7	43.4	14.2								
19.21	2.09	1.65	40.0	0.00	0.0	0.00	0.00	0.10	1.16	2000.00	2.00	2.00	2.00
2.00	0.60	0.00	126.9	43.6	14.3								
19.15	2.09	1.65	40.0	0.00	0.0	0.00	0.00	0.10	1.16	2000.00	2.00	2.00	2.00
2.00	0.60	0.00	127.2	43.9	14.4								
19.10	2.09	1.65	40.0	0.00	0.0	0.00	0.00	0.10	1.16	2000.00	2.00	2.00	2.00
2.00	0.60	0.00	127.4	44.1	14.5								
19.04	2.09	1.65	40.0	0.00	0.0	0.00	0.00	0.10	1.16	2000.00	2.00	2.00	2.00
2.00	0.61	0.00	127.7	44.4	14.6								
18.98	2.09	1.65	40.0	0.00	0.0	0.00	0.00	0.10	1.16	2000.00	2.00	2.00	2.00
2.00	0.61	0.00	127.9	44.6	14.7								
18.92	2.09	1.65	40.0	0.00	0.0	0.00	0.00	0.10	1.16	2000.00	2.00	2.00	2.00
2.00	0.61	0.00	128.2	44.9	14.7								
18.86	2.09	1.65	40.0	0.00	0.0	0.00	0.00	0.10	1.16	2000.00	2.00	2.00	2.00
2.00	0.62	0.00	128.4	45.1	14.8								
18.80	2.09	1.65	40.0	0.00	0.0	0.00	0.00	0.10	1.16	2000.00	2.00	2.00	2.00
2.00	0.62	0.00	128.7	45.4	14.9								
18.74	2.09	1.65	40.0	0.00	0.0	0.00	0.00	0.10	1.16	2000.00	2.00	2.00	2.00
2.00	0.62	0.00	128.9	45.6	15.0								
18.68	2.09	1.65	40.0	0.00	0.0	0.00	0.00	0.10	1.16	2000.00	2.00	2.00	2.00
2.00	0.63	0.00	129.2	45.9	15.1								
18.62	2.09	1.65	40.0	0.00	0.0	0.00	0.00	0.10	1.16	2000.00	2.00	2.00	2.00
2.00	0.63	0.00	129.4	46.1	15.1								
18.56	2.09	1.65	40.0	0.00	0.0	0.00	0.00	0.10	1.16	2000.00	2.00	2.00	2.00
2.00	0.63	0.00	129.6	46.4	15.2								
18.50	2.09	1.65	40.0	0.00	0.0	0.00	0.00	0.10	1.16	2000.00	2.00	2.00	2.00
2.00	0.64	0.00	129.9	46.6	15.3								
18.44	2.09	1.65	40.0	0.00	0.0	0.00	0.00	0.10	1.16	2000.00	2.00	2.00	2.00
2.00	0.64	0.00	130.1	46.9	15.4								
18.39	2.09	1.65	40.0	0.00	0.0	0.00	0.00	0.10	1.16	2000.00	2.00	2.00	2.00
2.00	0.64	0.00	130.4	47.1	15.5								
18.33	2.09	1.65	40.0	0.00	0.0	0.00	0.00	0.10	1.16	2000.00	2.00	2.00	2.00
2.00	0.65	0.00	130.6	47.4	15.6								
18.27	2.09	1.65	40.0	0.00	0.0	0.00	0.00	0.10	1.16	2000.00	2.00	2.00	2.00
2.00	0.65	0.00	130.9	47.6	15.6								
18.21	2.09	1.65	40.0	0.00	0.0	0.00	0.00	0.10	1.16	2000.00	2.00	2.00	2.00
2.00	0.65	0.00	131.1	47.9	15.7								
18.15	2.09	1.65	40.0	0.00	0.0	0.00	0.00	0.10	1.16	2000.00	2.00	2.00	2.00
2.00	0.66	0.00	131.4	48.1	15.8								
18.09	2.09	1.65	40.0	0.00	0.0	0.00	0.00	0.10	1.16	2000.00	2.00	2.00	2.00
2.00	0.66	0.00	131.6	48.4	15.9								
18.03	2.09	1.65	40.0	0.00	0.0	0.00	0.00	0.10	1.16	2000.00	2.00	2.00	2.00
2.00	0.67	0.00	131.9	48.6	16.0								
17.97	2.09	1.65	40.0	0.00	0.0	0.00	0.00	0.10	1.16	2000.00	2.00	2.00	2.00
2.00	0.67	0.00	132.1	48.9	16.1								
17.91	2.09	1.65	40.0	0.00	0.0	0.00	0.00	0.10	1.16	2000.00	2.00	2.00	2.00
2.00	0.67	0.00	132.4	49.1	16.1								
17.85	2.09	1.65	40.0	0.00	0.0	0.00	0.00	0.10	1.16	2000.00	2.00	2.00	2.00
2.00	0.68	0.00	132.6	49.4	16.2								

													0detail
17.79	2.09	1.65	40.0	0.00	0.0	0.00	0.00	0.10	1.16	2000.00	2.00	2.00	2.00
2.00	0.68	0.00	132.9	49.6	16.3								
17.74	2.09	1.65	40.0	0.00	0.0	0.00	0.00	0.10	1.16	2000.00	2.00	2.00	2.00
2.00	0.68	0.00	133.1	49.9	16.4								
17.68	2.09	1.65	40.0	0.00	0.0	0.00	0.00	0.10	1.16	2000.00	2.00	2.00	2.00
2.00	0.69	0.00	133.4	50.1	16.5								
17.62	2.09	1.65	40.0	0.00	0.0	0.00	0.00	0.10	1.16	2000.00	2.00	2.00	2.00
2.00	0.69	0.00	133.6	50.4	16.5								
17.56	2.09	1.65	40.0	0.00	0.0	0.00	0.00	0.10	1.16	2000.00	2.00	2.00	2.00
2.00	0.69	0.00	133.9	50.6	16.6								
17.50	2.09	1.65	40.0	0.00	0.0	0.00	0.00	0.10	1.16	2000.00	2.00	2.00	2.00
2.00	0.70	0.00	134.1	50.9	16.7								
17.44	2.09	1.65	40.0	0.00	0.0	0.00	0.00	0.10	1.16	2000.00	2.00	2.00	2.00
2.00	0.70	0.00	134.3	51.2	16.8								
17.38	2.09	1.65	40.0	0.00	0.0	0.00	0.00	0.10	1.16	2000.00	2.00	2.00	2.00
2.00	0.70	0.00	134.6	51.4	16.9								
17.32	2.09	1.65	40.0	0.00	0.0	0.00	0.00	0.10	1.16	2000.00	2.00	2.00	2.00
2.00	0.71	0.00	134.8	51.7	17.0								
17.26	2.09	1.65	40.0	0.00	0.0	0.00	0.00	0.10	1.16	2000.00	2.00	2.00	2.00
2.00	0.71	0.00	135.1	51.9	17.0								
17.20	2.09	1.65	40.0	0.00	0.0	0.00	0.00	0.10	1.16	2000.00	2.00	2.00	2.00
2.00	0.71	0.00	135.3	52.2	17.1								
17.14	2.09	1.65	40.0	0.00	0.0	0.00	0.00	0.10	1.16	2000.00	2.00	2.00	2.00
2.00	0.72	0.00	135.6	52.4	17.2								
17.09	2.09	1.65	40.0	0.00	0.0	0.00	0.00	0.10	1.16	2000.00	2.00	2.00	2.00
2.00	0.72	0.00	135.8	52.7	17.3								
17.03	2.09	1.65	40.0	0.00	0.0	0.00	0.00	0.10	1.16	2000.00	2.00	2.00	2.00
2.00	0.72	0.00	136.1	52.9	17.4								
16.97	2.09	1.65	40.0	0.00	0.0	0.00	0.00	0.10	1.16	2000.00	2.00	2.00	2.00
2.00	0.73	0.00	136.3	53.2	17.5								
16.91	2.09	1.65	40.0	0.00	0.0	0.00	0.00	0.10	1.16	2000.00	2.00	2.00	2.00
2.00	0.73	0.00	136.6	53.4	17.5								
16.85	2.09	1.65	40.0	0.00	0.0	0.00	0.00	0.10	1.16	2000.00	2.00	2.00	2.00
2.00	0.73	0.00	136.8	53.7	17.6								
16.79	2.09	1.65	40.0	0.00	0.0	0.00	0.00	0.10	1.16	2000.00	2.00	2.00	2.00
2.00	0.74	0.00	137.1	53.9	17.7								
16.73	2.09	1.65	40.0	0.00	0.0	0.00	0.00	0.10	1.16	2000.00	2.00	2.00	2.00
2.00	0.74	0.00	137.3	54.2	17.8								
16.67	2.09	1.65	40.0	0.00	0.0	0.00	0.00	0.10	1.16	2000.00	2.00	2.00	2.00
2.00	0.74	0.00	137.6	54.4	17.9								
16.61	2.09	1.65	40.0	0.00	0.0	0.00	0.00	0.10	1.16	2000.00	2.00	2.00	2.00
2.00	0.75	0.00	137.8	54.7	17.9								
16.55	2.09	1.65	40.0	0.00	0.0	0.00	0.00	0.10	1.16	2000.00	2.00	2.00	2.00
2.00	0.75	0.00	138.1	54.9	18.0								
16.49	2.09	1.65	40.0	0.00	0.0	0.00	0.00	0.10	1.16	2000.00	2.00	2.00	2.00
2.00	0.75	0.00	138.3	55.2	18.1								
16.43	2.09	1.65	40.0	0.00	0.0	0.00	0.00	0.10	1.16	2000.00	2.00	2.00	2.00
2.00	0.76	0.00	138.5	55.4	18.2								
16.38	2.09	1.65	40.0	0.00	0.0	0.00	0.00	0.10	1.16	2000.00	2.00	2.00	2.00
2.00	0.76	0.00	138.8	55.7	18.3								
16.32	2.09	1.65	40.0	0.00	0.0	0.00	0.00	0.10	1.16	2000.00	2.00	2.00	2.00
2.00	0.76	0.00	139.0	55.9	18.4								
16.26	2.09	1.65	40.0	0.00	0.0	0.00	0.00	0.10	1.16	2000.00	2.00	2.00	2.00
2.00	0.77	0.00	139.3	56.2	18.4								
16.20	2.09	1.65	40.0	0.00	0.0	0.00	0.00	0.10	1.16	2000.00	2.00	2.00	2.00
2.00	0.77	0.00	139.5	56.4	18.5								
16.14	2.09	1.65	40.0	0.00	0.0	0.00	0.00	0.10	1.16	2000.00	2.00	2.00	2.00
2.00	0.77	0.00	139.8	56.7	18.6								
16.08	2.09	1.65	40.0	0.00	0.0	0.00	0.00	0.10	1.16	2000.00	2.00	2.00	2.00
2.00	0.78	0.00	140.0	56.9	18.7								
16.02	2.09	1.65	40.0	0.00	0.0	0.00	0.00	0.10	1.16	2000.00	2.00	2.00	2.00
2.00	0.78	0.00	140.3	57.2	18.8								
15.96	2.09	1.65	30.0	0.00	0.0	0.00	0.00	0.10	1.16	2000.00	2.00	2.00	2.00
2.00	0.79	0.00	140.5	57.4	18.9								
15.90	2.09	1.65	30.0	0.00	0.0	0.00	0.00	0.10	1.16	2000.00	2.00	2.00	2.00
2.00	0.79	0.00	140.8	57.7	18.9								
15.84	2.09	1.65	30.0	0.00	0.0	0.00	0.00	0.10	1.16	2000.00	2.00	2.00	2.00

													Ødetail			
2.00	0.79	0.00	141.0	57.9	19.0											
15.78	2.09	1.65	30.0	0.00	0.0	0.00	0.00	0.10	1.16	2000.00	2.00	2.00	2.00			
2.00	0.80	0.00	141.3	58.2	19.1											
15.73	2.09	1.65	30.0	0.00	0.0	0.00	0.00	0.10	1.16	2000.00	2.00	2.00	2.00			
2.00	0.80	0.00	141.5	58.4	19.2											
15.67	2.09	1.65	30.0	0.00	0.0	0.00	0.00	0.10	1.16	2000.00	2.00	2.00	2.00			
2.00	0.80	0.00	141.8	58.7	19.3											
15.61	2.09	1.65	30.0	0.00	0.0	0.00	0.00	0.10	1.16	2000.00	2.00	2.00	2.00			
2.00	0.81	0.00	142.0	58.9	19.3											
15.55	2.09	1.65	30.0	0.00	0.0	0.00	0.00	0.10	1.16	2000.00	2.00	2.00	2.00			
2.00	0.81	0.00	142.3	59.2	19.4											
15.49	2.09	1.65	30.0	0.00	0.0	0.00	0.00	0.10	1.16	2000.00	2.00	2.00	2.00			
2.00	0.81	0.00	142.5	59.4	19.5											
15.43	2.09	1.65	30.0	0.00	0.0	0.00	0.00	0.10	1.16	2000.00	2.00	2.00	2.00			
2.00	0.82	0.00	142.8	59.7	19.6											
15.37	2.09	1.65	30.0	0.00	0.0	0.00	0.00	0.10	1.16	2000.00	2.00	2.00	2.00			
2.00	0.82	0.00	143.0	59.9	19.7											
15.31	2.09	1.65	30.0	0.00	0.0	0.00	0.00	0.10	1.16	2000.00	2.00	2.00	2.00			
2.00	0.82	0.00	143.2	60.2	19.8											
15.25	2.09	1.65	30.0	0.00	0.0	0.00	0.00	0.10	1.16	2000.00	2.00	2.00	2.00			
2.00	0.83	0.00	143.5	60.4	19.8											
15.19	2.09	1.65	30.0	0.00	0.0	0.00	0.00	0.10	1.16	2000.00	2.00	2.00	2.00			
2.00	0.83	0.00	143.7	60.7	19.9											
15.13	2.09	1.65	30.0	0.00	0.0	0.00	0.00	0.10	1.16	2000.00	2.00	2.00	2.00			
2.00	0.83	0.00	144.0	60.9	20.0											
15.08	2.09	1.65	30.0	0.00	0.0	0.00	0.00	0.10	1.16	2000.00	2.00	2.00	2.00			
2.00	0.84	0.00	144.2	61.2	20.1											
15.02	2.09	1.65	30.0	0.00	0.0	0.00	0.00	0.10	1.16	2000.00	2.00	2.00	2.00			
2.00	0.84	0.00	144.5	61.4	20.2											
14.96	2.09	1.65	30.0	0.00	0.0	0.00	0.00	0.10	1.16	2000.00	2.00	2.00	2.00			
2.00	0.84	0.00	144.7	61.7	20.3											
14.90	2.09	1.65	30.0	0.00	0.0	0.00	0.00	0.10	1.16	2000.00	2.00	2.00	2.00			
2.00	0.85	0.00	145.0	61.9	20.3											
14.84	2.09	1.65	30.0	0.00	0.0	0.00	0.00	0.10	1.16	2000.00	2.00	2.00	2.00			
2.00	0.85	0.00	145.2	62.2	20.4											
14.78	2.09	1.65	30.0	0.00	0.0	0.00	0.00	0.10	1.16	2000.00	2.00	2.00	2.00			
2.00	0.85	0.00	145.5	62.4	20.5											
14.72	2.09	1.65	30.0	0.00	0.0	0.00	0.00	0.10	1.16	2000.00	2.00	2.00	2.00			
2.00	0.86	0.00	145.7	62.7	20.6											
14.66	2.09	1.65	30.0	0.00	0.0	0.00	0.00	0.10	1.16	2000.00	2.00	2.00	2.00			
2.00	0.86	0.00	146.0	62.9	20.7											
14.60	2.09	1.65	30.0	0.00	0.0	0.00	0.00	0.10	1.16	2000.00	2.00	2.00	2.00			
2.00	0.86	0.00	146.2	63.2	20.7											
14.54	2.09	1.65	30.0	0.00	0.0	0.00	0.00	0.10	1.16	2000.00	2.00	2.00	2.00			
2.00	0.87	0.00	146.5	63.4	20.8											
14.48	2.09	1.65	30.0	0.00	0.0	0.00	0.00	0.10	1.16	2000.00	2.00	2.00	2.00			
2.00	0.87	0.00	146.7	63.7	20.9											
14.42	2.09	1.65	30.0	0.00	0.0	0.00	0.00	0.10	1.16	2000.00	2.00	2.00	2.00			
2.00	0.87	0.00	147.0	63.9	21.0											
14.37	2.09	1.65	30.0	0.00	0.0	0.00	0.00	0.10	1.16	2000.00	2.00	2.00	2.00			
2.00	0.88	0.00	147.2	64.2	21.1											
14.31	2.09	1.65	30.0	0.00	0.0	0.00	0.00	0.10	1.16	2000.00	2.00	2.00	2.00			
2.00	0.88	0.00	147.5	64.4	21.2											
14.25	2.09	1.65	30.0	0.00	0.0	0.00	0.00	0.10	1.16	2000.00	2.00	2.00	2.00			
2.00	0.88	0.00	147.7	64.7	21.2											
14.19	2.09	1.65	30.0	0.00	0.0	0.00	0.00	0.10	1.16	2000.00	2.00	2.00	2.00			
2.00	0.89	0.00	147.9	64.9	21.3											
14.13	2.09	1.65	30.0	0.00	0.0	0.00	0.00	0.10	1.16	2000.00	2.00	2.00	2.00			
2.00	0.89	0.00	148.2	65.2	21.4											
14.07	2.09	1.65	30.0	0.00	0.0	0.00	0.00	0.10	1.16	2000.00	2.00	2.00	2.00			
2.00	0.89	0.00	148.4	65.4	21.5											
14.01	2.09	1.65	30.0	0.00	0.0	0.00	0.00	0.10	1.16	2000.00	2.00	2.00	2.00			
2.00	0.90	0.00	148.7	65.7	21.6											
13.95	2.09	1.65	30.0	0.00	0.0	0.00	0.00	0.10	1.16	2000.00	2.00	2.00	2.00			
2.00	0.90	0.00	148.9	65.9	21.7											
13.89	2.09	1.65	30.0	0.00	0.0	0.00	0.00	0.10	1.16	2000.00	2.00	2.00	2.00			
2.00	0.91	0.00	149.2	66.2	21.7											

													0detail
13.83	2.09	1.65	30.0	0.00	0.0	0.00	0.00	0.10	1.16	2000.00	2.00	2.00	2.00
2.00	0.91	0.00	149.4	66.4	21.8								
13.77	2.09	1.65	30.0	0.00	0.0	0.00	0.00	0.10	1.16	2000.00	2.00	2.00	2.00
2.00	0.91	0.00	149.7	66.7	21.9								
13.72	2.09	1.65	30.0	0.00	0.0	0.00	0.00	0.10	1.16	2000.00	2.00	2.00	2.00
2.00	0.92	0.00	149.9	66.9	22.0								
13.66	2.09	1.65	30.0	0.00	0.0	0.00	0.00	0.10	1.16	2000.00	2.00	2.00	2.00
2.00	0.92	0.00	150.2	67.2	22.1								
13.60	2.09	1.65	30.0	0.00	0.0	0.00	0.00	0.10	1.16	2000.00	2.00	2.00	2.00
2.00	0.92	0.00	150.4	67.4	22.1								
13.54	2.09	1.65	30.0	0.00	0.0	0.00	0.00	0.10	1.16	2000.00	2.00	2.00	2.00
2.00	0.93	0.00	150.7	67.7	22.2								
13.48	2.09	1.65	30.0	0.00	0.0	0.00	0.00	0.10	1.16	2000.00	2.00	2.00	2.00
2.00	0.93	0.00	150.9	68.0	22.3								
13.42	2.09	1.65	30.0	0.00	0.0	0.00	0.00	0.10	1.16	2000.00	2.00	2.00	2.00
2.00	0.93	0.00	151.2	68.2	22.4								
13.36	2.09	1.65	30.0	0.00	0.0	0.00	0.00	0.10	1.16	2000.00	2.00	2.00	2.00
2.00	0.94	0.00	151.4	68.5	22.5								
13.30	2.09	1.65	30.0	0.00	0.0	0.00	0.00	0.10	1.16	2000.00	2.00	2.00	2.00
2.00	0.94	0.00	151.7	68.7	22.6								
13.24	2.09	1.64	30.0	0.00	0.0	0.00	0.00	0.10	1.16	2000.00	2.00	2.00	2.00
2.00	0.94	0.00	151.9	69.0	22.6								
13.18	2.09	1.64	30.0	0.00	0.0	0.00	0.00	0.10	1.16	2000.00	2.00	2.00	2.00
2.00	0.95	0.00	152.2	69.2	22.7								
13.12	2.09	1.63	30.0	0.00	0.0	0.00	0.00	0.10	1.16	2000.00	2.00	2.00	2.00
2.00	0.95	0.00	152.4	69.5	22.8								
13.07	2.09	1.62	30.0	0.00	0.0	0.00	0.00	0.10	1.16	2000.00	2.00	2.00	2.00
2.00	0.95	0.00	152.6	69.7	22.9								
13.01	2.09	1.61	30.0	0.00	0.0	0.00	0.00	0.10	1.16	2000.00	2.00	2.00	2.00
2.00	0.96	0.00	152.9	70.0	23.0								
12.95	2.09	1.61	30.0	0.00	0.0	0.00	0.00	0.10	1.16	2000.00	2.00	2.00	2.00
2.00	0.96	0.00	153.1	70.2	23.1								
12.89	2.09	1.60	30.0	0.00	0.0	0.00	0.00	0.10	1.16	2000.00	2.00	2.00	2.00
2.00	0.96	0.00	153.4	70.5	23.1								
12.83	2.09	1.59	30.0	0.00	0.0	0.00	0.00	0.10	1.16	2000.00	2.00	2.00	2.00
2.00	0.97	0.00	153.6	70.7	23.2								
12.77	2.09	1.59	30.0	0.00	0.0	0.00	0.00	0.10	1.16	2000.00	2.00	2.00	2.00
2.00	0.97	0.00	153.9	71.0	23.3								
12.71	2.09	1.58	30.0	0.00	0.0	0.00	0.00	0.10	1.16	2000.00	2.00	2.00	2.00
2.00	0.97	0.00	154.1	71.2	23.4								
12.65	2.09	1.57	30.0	0.00	0.0	0.00	0.00	0.10	1.16	2000.00	2.00	2.00	2.00
2.00	0.98	0.00	154.4	71.5	23.5								
12.59	2.09	1.57	30.0	0.00	0.0	0.00	0.00	0.10	1.16	2000.00	2.00	2.00	2.00
2.00	0.98	0.00	154.6	71.7	23.5								
12.53	2.09	1.56	30.0	0.00	0.0	0.00	0.00	0.10	1.16	2000.00	2.00	2.00	2.00
2.00	0.98	0.00	154.9	72.0	23.6								
12.47	2.09	1.55	30.0	0.00	0.0	0.00	0.00	0.10	1.16	2000.00	2.00	2.00	2.00
2.00	0.99	0.00	155.1	72.2	23.7								
12.41	2.09	1.54	30.0	0.00	0.0	0.00	0.00	0.10	1.16	2000.00	2.00	2.00	2.00
2.00	0.99	0.00	155.4	72.5	23.8								
12.36	2.09	1.54	30.0	0.00	0.0	0.00	0.00	0.10	1.16	2000.00	2.00	2.00	2.00
2.00	0.99	0.00	155.6	72.7	23.9								
12.30	2.09	1.53	30.0	0.00	0.0	0.00	0.00	0.10	1.16	2000.00	2.00	2.00	2.00
2.00	1.00	0.00	155.9	73.0	24.0								
12.24	2.09	1.52	30.0	0.00	0.0	0.00	0.00	0.10	1.16	2000.00	2.00	2.00	2.00
2.00	1.00	0.00	156.1	73.2	24.0								
12.18	2.09	1.52	30.0	0.00	0.0	0.00	0.00	0.10	1.16	2000.00	2.00	2.00	2.00
2.00	1.00	0.00	156.4	73.5	24.1								
12.12	2.09	1.51	30.0	0.00	0.0	0.00	0.00	0.10	1.16	2000.00	2.00	2.00	2.00
2.00	1.01	0.00	156.6	73.7	24.2								
12.06	2.09	1.50	30.0	0.00	0.0	0.00	0.00	0.10	1.16	2000.00	2.00	2.00	2.00
2.00	1.01	0.00	156.9	74.0	24.3								
12.00	2.09	1.49	30.0	0.00	0.0	0.00	0.00	0.10	1.16	2000.00	2.00	2.00	2.00
2.00	1.01	0.00	157.1	74.2	24.4								
11.94	2.09	1.49	30.0	0.00	0.0	0.00	0.00	0.10	1.16	2000.00	2.00	2.00	2.00
2.00	1.02	0.00	157.3	74.5	24.5								
11.88	2.09	1.48	30.0	0.00	0.0	0.00	0.00	0.10	1.16	2000.00	2.00	2.00	2.00

														Ødetail			
2.00	1.02	0.00	157.6	74.7	24.5												
11.82	2.09	1.47	30.0	0.00	0.0	0.00	0.00	0.10	1.16	2000.00	2.00	2.00	2.00				
2.00	1.03	0.00	157.8	75.0	24.6												
11.76	2.09	1.47	30.0	0.00	0.0	0.00	0.00	0.10	1.16	2000.00	2.00	2.00	2.00				
2.00	1.03	0.00	158.1	75.2	24.7												
11.71	2.09	1.46	30.0	0.00	0.0	0.00	0.00	0.10	1.16	2000.00	2.00	2.00	2.00				
2.00	1.03	0.00	158.3	75.5	24.8												
11.65	2.09	1.45	30.0	0.00	0.0	0.00	0.00	0.10	1.16	2000.00	2.00	2.00	2.00				
2.00	1.04	0.00	158.6	75.7	24.9												
11.59	2.09	1.44	30.0	0.00	0.0	0.00	0.00	0.10	1.16	2000.00	2.00	2.00	2.00				
2.00	1.04	0.00	158.8	76.0	24.9												
11.53	2.09	1.44	30.0	0.00	0.0	0.00	0.00	0.10	1.16	2000.00	2.00	2.00	2.00				
2.00	1.04	0.00	159.1	76.2	25.0												
11.47	2.09	1.43	30.0	0.00	0.0	0.00	0.00	0.10	1.16	2000.00	2.00	2.00	2.00				
2.00	1.05	0.00	159.3	76.5	25.1												
11.41	2.09	1.42	30.0	0.00	0.0	0.00	0.00	0.10	1.16	2000.00	2.00	2.00	2.00				
2.00	1.05	0.00	159.6	76.7	25.2												
11.35	2.09	1.42	30.0	0.00	0.0	0.00	0.00	0.10	1.16	2000.00	2.00	2.00	2.00				
2.00	1.05	0.00	159.8	77.0	25.3												
11.29	2.09	1.41	30.0	0.00	0.0	0.00	0.00	0.10	1.16	2000.00	2.00	2.00	2.00				
2.00	1.06	0.00	160.1	77.2	25.4												
11.23	2.09	1.40	30.0	0.00	0.0	0.00	0.00	0.10	1.16	2000.00	2.00	2.00	2.00				
2.00	1.06	0.00	160.3	77.5	25.4												
11.17	2.09	1.39	30.0	0.00	0.0	0.00	0.00	0.10	1.16	2000.00	2.00	2.00	2.00				
2.00	1.06	0.00	160.6	77.7	25.5												
11.11	2.09	1.39	30.0	0.00	0.0	0.00	0.00	0.10	1.16	2000.00	2.00	2.00	2.00				
2.00	1.07	0.00	160.8	78.0	25.6												
11.06	2.09	1.38	30.0	0.00	0.0	0.00	0.00	0.10	1.16	2000.00	2.00	2.00	2.00				
2.00	1.07	0.00	161.1	78.2	25.7												
11.00	2.09	1.37	30.0	0.00	0.0	0.00	0.00	0.10	1.16	2000.00	2.00	2.00	2.00				
2.00	1.07	0.00	161.3	78.5	25.8												
10.94	2.09	1.37	30.0	0.00	0.0	0.00	0.00	0.10	1.16	2000.00	2.00	2.00	2.00				
2.00	1.08	0.00	161.5	78.7	25.9												
10.88	2.09	1.36	30.0	0.00	0.0	0.00	0.00	0.10	1.16	2000.00	2.00	2.00	2.00				
2.00	1.08	0.00	161.8	79.0	25.9												
10.82	2.09	1.35	30.0	0.00	0.0	0.00	0.00	0.10	1.16	2000.00	2.00	2.00	2.00				
2.00	1.08	0.00	162.0	79.2	26.0												
10.76	2.09	1.35	30.0	0.00	0.0	0.00	0.00	0.10	1.16	2000.00	2.00	2.00	2.00				
2.00	1.09	0.00	162.3	79.5	26.1												
10.70	2.09	1.34	30.0	0.00	0.0	0.00	0.00	0.10	1.16	2000.00	2.00	2.00	2.00				
2.00	1.09	0.00	162.5	79.7	26.2												
10.64	2.09	1.33	30.0	0.00	0.0	0.00	0.00	0.10	1.16	2000.00	2.00	2.00	2.00				
2.00	1.09	0.00	162.8	80.0	26.3												
10.58	2.09	1.32	30.0	0.00	0.0	0.00	0.00	0.10	1.16	2000.00	2.00	2.00	2.00				
2.00	1.10	0.00	163.0	80.2	26.3												
10.52	2.09	1.32	30.0	0.00	0.0	0.00	0.00	0.10	1.16	2000.00	2.00	2.00	2.00				
2.00	1.10	0.00	163.3	80.5	26.4												
10.46	2.09	1.31	30.0	0.00	0.0	0.00	0.00	0.10	1.16	2000.00	2.00	2.00	2.00				
2.00	1.10	0.00	163.5	80.7	26.5												
10.40	2.09	1.30	30.0	0.00	0.0	0.00	0.00	0.10	1.16	2000.00	2.00	2.00	2.00				
2.00	1.11	0.00	163.8	81.0	26.6												
10.35	2.09	1.30	30.0	0.00	0.0	0.00	0.00	0.10	1.16	2000.00	2.00	2.00	2.00				
2.00	1.11	0.00	164.0	81.2	26.7												
10.29	2.09	1.29	30.0	0.00	0.0	0.00	0.00	0.10	1.16	2000.00	2.00	2.00	2.00				
2.00	1.11	0.00	164.3	81.5	26.8												
10.23	2.09	1.28	30.0	0.00	0.0	0.00	0.00	0.10	1.16	2000.00	2.00	2.00	2.00				
2.00	1.12	0.00	164.5	81.7	26.8												
10.17	2.09	1.27	30.0	0.00	0.0	0.00	0.00	0.10	1.16	2000.00	2.00	2.00	2.00				
2.00	1.12	0.00	164.8	82.0	26.9												
10.11	2.09	1.27	30.0	0.00	0.0	0.00	0.00	0.10	1.16	2000.00	2.00	2.00	2.00				
2.00	1.12	0.00	165.0	82.2	27.0												
10.05	2.09	1.26	30.0	0.00	0.0	0.00	0.00	0.10	1.16	2000.00	2.00	2.00	2.00				
2.00	1.13	0.00	165.3	82.5	27.1												
9.99	2.09	1.25	37.0	0.00	0.0	0.00	0.00	0.75	0.78	2000.00	2.00	2.00	2.00				
2.00	1.13	0.00	165.5	82.7	27.2												
9.93	2.09	1.25	37.0	0.00	0.0	0.00	0.00	0.75	0.78	2000.00	2.00	2.00	2.00				
2.00	1.13	0.00	165.8	83.0	27.3												

													0detail
9.87	2.09	1.24	37.0	0.00	0.0	0.00	0.00	0.75	0.78	2000.00	2.00	2.00	2.00
2.00	1.14	0.00	166.0	83.2	27.3								
9.81	2.09	1.23	37.0	0.00	0.0	0.00	0.00	0.75	0.78	2000.00	2.00	2.00	2.00
2.00	1.14	0.00	166.2	83.5	27.4								
9.75	2.09	1.22	37.0	0.00	0.0	0.00	0.00	0.75	0.78	2000.00	2.00	2.00	2.00
2.00	1.15	0.00	166.5	83.7	27.5								
9.70	2.09	1.22	37.0	0.00	0.0	0.00	0.00	0.75	0.78	2000.00	2.00	2.00	2.00
2.00	1.15	0.00	166.7	84.0	27.6								
9.64	2.09	1.21	37.0	0.00	0.0	0.00	0.00	0.75	0.78	2000.00	2.00	2.00	2.00
2.00	1.15	0.00	167.0	84.2	27.7								
9.58	2.09	1.20	37.0	0.00	0.0	0.00	0.00	0.75	0.78	2000.00	2.00	2.00	2.00
2.00	1.16	0.00	167.2	84.5	27.7								
9.52	2.09	1.19	37.0	0.00	0.0	0.00	0.00	0.75	0.78	2000.00	2.00	2.00	2.00
2.00	1.16	0.00	167.5	84.8	27.8								
9.46	1.73	1.19	37.0	20.00	20.0	0.43	0.43	0.75	0.78	1.00	0.58	0.58	1.02
1.02	1.16	0.00	167.6	84.9	27.9								
9.40	1.73	1.18	37.0	20.00	20.0	0.43	0.43	0.75	0.78	1.00	0.58	0.58	1.01
1.01	1.17	0.00	167.7	85.0	27.9								
9.34	1.73	1.17	37.0	20.00	20.0	0.43	0.43	0.75	0.78	1.00	0.58	0.58	1.01
1.01	1.17	0.00	167.8	85.1	27.9								
9.28	1.73	1.16	37.0	20.00	20.0	0.42	0.42	0.75	0.78	1.00	0.58	0.58	1.01
1.01	1.17	0.00	167.9	85.2	27.9								
9.22	1.73	1.16	37.0	20.00	20.0	0.42	0.42	0.75	0.78	1.00	0.58	0.58	1.01
1.01	1.18	0.00	168.0	85.3	28.0								
9.16	1.73	1.15	37.0	20.00	20.0	0.42	0.42	0.75	0.78	1.00	0.58	0.58	1.00
1.00	1.18	0.00	168.1	85.4	28.0								
9.10	1.73	1.14	37.0	20.00	20.0	0.42	0.42	0.75	0.78	1.00	0.58	0.58	1.00
1.00	1.18	0.00	168.2	85.5	28.0								
9.05	1.73	1.13	37.0	20.00	20.0	0.41	0.41	0.75	0.78	1.00	0.58	0.58	1.00
1.00	1.19	0.00	168.3	85.6	28.1								
8.99	1.73	1.13	37.0	20.00	20.0	0.41	0.41	0.75	0.78	1.00	0.58	0.58	0.99
0.99	1.19	0.00	168.4	85.7	28.1								
8.93	1.73	1.12	37.0	20.00	20.0	0.41	0.41	0.75	0.78	1.00	0.58	0.58	0.99
0.99	1.19	0.00	168.5	85.8	28.1								
8.87	1.73	1.11	37.0	20.00	20.0	0.40	0.40	0.75	0.78	1.00	0.58	0.58	0.99
0.99	1.20	0.00	168.6	85.9	28.1								
8.81	1.73	1.10	37.0	20.00	20.0	0.40	0.40	0.75	0.78	1.00	0.58	0.58	0.99
0.99	1.20	0.00	168.7	86.0	28.2								
8.75	1.73	1.10	37.0	20.00	20.0	0.40	0.40	0.75	0.78	1.00	0.58	0.58	0.98
0.98	1.20	0.00	168.8	86.1	28.2								
8.69	1.73	1.09	37.0	20.00	20.0	0.40	0.40	0.75	0.78	1.00	0.58	0.58	0.98
0.98	1.21	0.00	168.9	86.2	28.2								
8.63	1.73	1.08	37.0	20.00	20.0	0.39	0.39	0.75	0.78	1.00	0.58	0.58	0.98
0.98	1.21	0.00	169.0	86.3	28.3								
8.57	1.73	1.08	37.0	20.00	20.0	0.39	0.39	0.75	0.78	1.00	0.58	0.58	0.98
0.98	1.21	0.00	169.1	86.4	28.3								
8.51	1.73	1.07	37.0	20.00	20.0	0.39	0.39	0.75	0.78	1.00	0.58	0.58	0.97
0.97	1.22	0.00	169.2	86.5	28.3								
8.45	1.73	1.06	37.0	20.00	20.0	0.39	0.39	0.75	0.78	1.00	0.58	0.58	0.97
0.97	1.22	0.00	169.3	86.6	28.3								
8.39	1.73	1.05	37.0	20.00	20.0	0.38	0.38	0.75	0.78	1.00	0.58	0.58	0.97
0.97	1.22	0.00	169.4	86.7	28.4								
8.34	1.73	1.05	37.0	20.00	20.0	0.38	0.38	0.75	0.78	1.00	0.58	0.58	0.97
0.97	1.23	0.00	169.5	86.8	28.4								
8.28	1.73	1.04	37.0	20.00	20.0	0.38	0.38	0.75	0.78	1.00	0.58	0.58	0.96
0.96	1.23	0.00	169.6	86.9	28.4								
8.22	1.73	1.03	37.0	20.00	20.0	0.38	0.38	0.75	0.78	1.00	0.58	0.58	0.96
0.96	1.23	0.00	169.7	87.1	28.4								
8.16	1.73	1.02	37.0	20.00	20.0	0.37	0.37	0.75	0.78	1.00	0.58	0.58	0.96
0.96	1.24	0.00	169.8	87.2	28.5								
8.10	1.73	1.02	37.0	20.00	20.0	0.37	0.37	0.75	0.78	1.00	0.58	0.58	0.95
0.95	1.24	0.00	169.9	87.3	28.5								
8.04	1.73	1.01	37.0	20.00	20.0	0.37	0.37	0.75	0.78	1.00	0.58	0.58	0.95
0.95	1.24	0.00	170.0	87.4	28.5								
7.98	1.73	1.00	37.0	20.00	20.0	0.36	0.36	0.75	0.78	1.00	0.58	0.58	0.95
0.95	1.25	0.00	170.1	87.5	28.5								
7.92	1.73	0.99	37.0	20.00	20.0	0.36	0.36	0.75	0.78	1.00	0.58	0.58	0.95

Ødetail

0.95	1.25	0.00	170.2	87.6	28.6								
7.86	1.73	0.99	37.0	20.00	20.0	0.36	0.36	0.75	0.78	1.00	0.58	0.58	0.94
0.94	1.25	0.00	170.3	87.7	28.6								
7.80	1.73	0.98	37.0	20.00	20.0	0.36	0.36	0.75	0.78	1.00	0.58	0.58	0.94
0.94	1.25	0.00	170.4	87.8	28.6								
7.74	1.73	0.97	37.0	20.00	20.0	0.35	0.35	0.75	0.78	1.00	0.58	0.58	0.94
0.94	1.26	0.00	170.5	87.9	28.7								
7.69	1.73	0.96	37.0	20.00	20.0	0.35	0.35	0.75	0.78	1.00	0.58	0.58	0.94
0.94	1.26	0.00	170.6	88.0	28.7								
7.63	1.73	0.96	37.0	20.00	20.0	0.35	0.35	0.75	0.78	1.00	0.58	0.58	0.93
0.93	1.26	0.00	170.7	88.1	28.7								
7.57	1.73	0.95	37.0	20.00	20.0	0.35	0.35	0.75	0.78	1.00	0.58	0.58	0.93
0.93	1.27	0.00	170.8	88.1	28.7								
7.51	1.73	0.94	37.0	20.00	20.0	0.34	0.34	0.75	0.78	1.00	0.58	0.58	0.93
0.93	1.27	0.00	170.9	88.2	28.8								
7.45	1.73	0.93	37.0	20.00	20.0	0.34	0.34	0.75	0.78	1.00	0.58	0.58	0.92
0.92	1.27	0.00	171.0	88.3	28.8								
7.39	1.73	0.93	37.0	20.00	20.0	0.34	0.34	0.75	0.78	1.00	0.58	0.58	0.92
0.92	1.28	0.00	171.1	88.4	28.8								
7.33	1.73	0.92	37.0	20.00	20.0	0.33	0.33	0.75	0.78	1.00	0.58	0.58	0.92
0.92	1.28	0.00	171.2	88.5	28.8								
7.27	1.73	0.91	37.0	20.00	20.0	0.33	0.33	0.75	0.78	1.00	0.58	0.58	0.92
0.92	1.28	0.00	171.2	88.6	28.9								
7.21	1.73	0.91	37.0	20.00	20.0	0.33	0.33	0.75	0.78	1.00	0.58	0.58	0.91
0.91	1.29	0.00	171.3	88.7	28.9								
7.15	1.73	0.90	37.0	20.00	20.0	0.33	0.33	0.75	0.78	1.00	0.58	0.58	0.91
0.91	1.29	0.00	171.4	88.8	28.9								
7.09	1.73	0.89	37.0	20.00	20.0	0.32	0.32	0.75	0.78	1.00	0.58	0.58	0.91
0.91	1.29	0.00	171.5	88.9	28.9								
7.04	1.73	0.88	37.0	20.00	20.0	0.32	0.32	0.75	0.78	1.00	0.58	0.58	0.91
0.91	1.30	0.00	171.6	89.0	29.0								
6.98	1.73	0.88	37.0	20.00	20.0	0.32	0.32	0.75	0.78	1.00	0.58	0.58	0.90
0.90	1.30	0.00	171.7	89.1	29.0								
6.92	1.73	0.87	37.0	20.00	20.0	0.32	0.32	0.75	0.78	1.00	0.58	0.58	0.90
0.90	1.30	0.00	171.8	89.2	29.0								
6.86	1.73	0.86	37.0	20.00	20.0	0.31	0.31	0.75	0.78	1.00	0.58	0.58	0.90
0.90	1.31	0.00	171.9	89.3	29.0								
6.80	1.73	0.85	37.0	20.00	20.0	0.31	0.31	0.75	0.78	1.00	0.58	0.58	0.90
0.90	1.31	0.00	172.0	89.4	29.1								
6.74	1.73	0.85	37.0	20.00	20.0	0.31	0.31	0.75	0.78	1.00	0.58	0.58	0.89
0.89	1.31	0.00	172.1	89.5	29.1								
6.68	1.73	0.84	37.0	20.00	20.0	0.31	0.31	0.75	0.78	1.00	0.58	0.58	0.89
0.89	1.32	0.00	172.2	89.6	29.1								
6.62	1.73	0.83	37.0	20.00	20.0	0.30	0.30	0.75	0.78	1.00	0.58	0.58	0.89
0.89	1.32	0.00	172.3	89.7	29.1								
6.56	1.73	0.82	37.0	20.00	20.0	0.30	0.30	0.75	0.78	1.00	0.58	0.58	0.88
0.88	1.32	0.00	172.4	89.8	29.2								
6.50	1.73	0.82	37.0	20.00	20.0	0.30	0.30	0.75	0.78	1.00	0.58	0.58	0.88
0.88	1.33	0.00	172.4	89.9	29.2								
6.44	1.73	0.81	37.0	20.00	20.0	0.29	0.29	0.75	0.78	1.00	0.58	0.58	0.88
0.88	1.33	0.00	172.5	90.0	29.2								
6.38	1.73	0.80	37.0	20.00	20.0	0.29	0.29	0.75	0.78	1.00	0.58	0.58	0.88
0.88	1.33	0.00	172.6	90.1	29.2								
6.33	1.73	0.79	37.0	20.00	20.0	0.29	0.29	0.75	0.78	1.00	0.58	0.58	0.87
0.87	1.34	0.00	172.7	90.2	29.3								
6.27	1.73	0.79	37.0	20.00	20.0	0.29	0.29	0.75	0.78	1.00	0.58	0.58	0.87
0.87	1.34	0.00	172.8	90.2	29.3								
6.21	1.73	0.78	37.0	20.00	20.0	0.28	0.28	0.75	0.78	1.00	0.58	0.58	0.87
0.87	1.34	0.00	172.9	90.3	29.3								
6.15	1.73	0.77	37.0	20.00	20.0	0.28	0.28	0.75	0.78	1.00	0.58	0.58	0.87
0.87	1.35	0.00	173.0	90.4	29.3								
6.09	1.73	0.76	37.0	20.00	20.0	0.28	0.28	0.75	0.78	1.00	0.58	0.58	0.86
0.86	1.35	0.00	173.1	90.5	29.4								
6.03	1.73	0.76	37.0	20.00	20.0	0.28	0.28	0.75	0.78	1.00	0.58	0.58	0.86
0.86	1.35	0.00	173.2	90.6	29.4								
5.97	1.73	0.75	37.0	20.00	20.0	0.27	0.27	0.75	0.78	1.00	0.58	0.58	0.86
0.86	1.36	0.00	173.2	90.7	29.4								

														0detail
5.91	1.73	0.74	37.0	20.00	20.0	0.27	0.27	0.75	0.78	1.00	0.58	0.58	0.85	
0.85	1.36	0.00	173.3	90.8	29.4									
5.85	1.73	0.74	37.0	20.00	20.0	0.27	0.27	0.75	0.78	1.00	0.58	0.58	0.85	
0.85	1.36	0.00	173.4	90.9	29.5									
5.79	1.73	0.73	37.0	20.00	20.0	0.26	0.26	0.75	0.78	1.00	0.58	0.58	0.85	
0.85	1.37	0.00	173.5	91.0	29.5									
5.73	1.73	0.72	37.0	20.00	20.0	0.26	0.26	0.75	0.78	1.00	0.58	0.58	0.85	
0.85	1.37	0.00	173.6	91.1	29.5									
5.68	1.73	0.71	37.0	20.00	20.0	0.26	0.26	0.75	0.78	1.00	0.58	0.58	0.84	
0.84	1.37	0.00	173.7	91.2	29.5									
5.62	1.73	0.71	37.0	20.00	20.0	0.26	0.26	0.75	0.78	1.00	0.58	0.58	0.84	
0.84	1.38	0.00	173.8	91.2	29.6									
5.56	1.73	0.70	37.0	20.00	20.0	0.25	0.25	0.75	0.78	1.00	0.58	0.58	0.84	
0.84	1.38	0.00	173.9	91.3	29.6									
5.50	1.73	0.69	37.0	20.00	20.0	0.25	0.25	0.75	0.78	1.00	0.58	0.58	0.84	
0.84	1.38	0.00	173.9	91.4	29.6									
5.44	1.73	0.68	37.0	20.00	20.0	0.25	0.25	0.75	0.78	1.00	0.58	0.58	0.83	
0.83	1.39	0.00	174.0	91.5	29.6									
5.38	1.73	0.68	37.0	20.00	20.0	0.25	0.25	0.75	0.78	1.00	0.58	0.58	0.83	
0.83	1.39	0.00	174.1	91.6	29.7									
5.32	1.73	0.67	37.0	20.00	20.0	0.24	0.24	0.75	0.78	1.00	0.58	0.58	0.83	
0.83	1.39	0.00	174.2	91.7	29.7									
5.26	1.73	0.66	37.0	20.00	20.0	0.24	0.24	0.75	0.78	1.00	0.58	0.58	0.83	
0.83	1.40	0.00	174.3	91.8	29.7									
5.20	1.73	0.65	37.0	20.00	20.0	0.24	0.24	0.75	0.78	1.00	0.58	0.58	0.82	
0.82	1.40	0.00	174.4	91.9	29.7									
5.14	1.73	0.65	37.0	20.00	20.0	0.24	0.24	0.75	0.78	1.00	0.58	0.58	0.82	
0.82	1.40	0.00	174.4	92.0	29.7									
5.08	1.73	0.64	37.0	20.00	20.0	0.23	0.23	0.75	0.78	1.00	0.58	0.58	0.82	
0.82	1.41	0.00	174.5	92.0	29.8									
5.03	1.73	0.63	37.0	20.00	20.0	0.23	0.23	0.75	0.78	1.00	0.58	0.58	0.81	
0.81	1.41	0.00	174.6	92.1	29.8									
4.97	1.73	0.62	37.0	20.00	20.0	0.23	0.23	0.75	0.78	1.00	0.58	0.58	0.81	
0.81	1.41	0.00	174.7	92.2	29.8									
4.91	1.73	0.62	37.0	20.00	20.0	0.22	0.22	0.75	0.78	1.00	0.58	0.58	0.81	
0.81	1.42	0.00	174.8	92.3	29.8									
4.85	1.73	0.61	37.0	20.00	20.0	0.22	0.22	0.75	0.78	1.00	0.58	0.58	0.81	
0.81	1.42	0.00	174.9	92.4	29.9									
4.79	1.73	0.60	37.0	20.00	20.0	0.22	0.22	0.75	0.78	1.00	0.58	0.58	0.80	
0.80	1.42	0.00	174.9	92.5	29.9									
4.73	1.73	0.59	37.0	20.00	20.0	0.22	0.22	0.75	0.78	1.00	0.58	0.58	0.80	
0.80	1.43	0.00	175.0	92.6	29.9									
4.67	1.73	0.59	37.0	20.00	20.0	0.21	0.21	0.75	0.78	1.00	0.58	0.58	0.80	
0.80	1.43	0.00	175.1	92.6	29.9									
4.61	1.73	0.58	37.0	20.00	20.0	0.21	0.21	0.75	0.78	1.00	0.58	0.58	0.80	
0.80	1.43	0.00	175.2	92.7	30.0									
4.55	1.73	0.57	37.0	20.00	20.0	0.21	0.21	0.75	0.78	1.00	0.58	0.58	0.79	
0.79	1.44	0.00	175.3	92.8	30.0									
4.49	1.73	0.57	37.0	20.00	20.0	0.21	0.21	0.75	0.78	1.00	0.58	0.58	0.79	
0.79	1.44	0.00	175.4	92.9	30.0									
4.43	1.73	0.56	37.0	20.00	20.0	0.20	0.20	0.75	0.78	1.00	0.58	0.58	0.79	
0.79	1.44	0.00	175.4	93.0	30.0									
4.37	1.73	0.55	37.0	20.00	20.0	0.20	0.20	0.75	0.78	1.00	0.58	0.58	0.78	
0.78	1.45	0.00	175.5	93.1	30.0									
4.32	1.73	0.54	37.0	20.00	20.0	0.20	0.20	0.75	0.78	1.00	0.58	0.58	0.78	
0.78	1.45	0.00	175.6	93.1	30.1									
4.26	1.73	0.54	37.0	20.00	20.0	0.20	0.20	0.75	0.78	1.00	0.58	0.58	0.78	
0.78	1.45	0.00	175.7	93.2	30.1									
4.20	1.73	0.53	37.0	20.00	20.0	0.19	0.19	0.75	0.78	1.00	0.58	0.58	0.78	
0.78	1.46	0.00	175.8	93.3	30.1									
4.14	1.73	0.52	37.0	20.00	20.0	0.19	0.19	0.75	0.78	1.00	0.58	0.58	0.77	
0.77	1.46	0.00	175.8	93.4	30.1									
4.08	1.73	0.51	37.0	20.00	20.0	0.19	0.19	0.75	0.78	1.00	0.58	0.58	0.77	
0.77	1.46	0.00	175.9	93.5	30.2									
4.02	1.73	0.51	37.0	20.00	20.0	0.18	0.18	0.75	0.78	1.00	0.58	0.58	0.77	
0.77	1.47	0.00	176.0	93.6	30.2									
3.96	1.73	0.50	37.0	20.00	20.0	0.18	0.18	0.75	0.78	1.00	0.58	0.58	0.77	

Ødetail													
0.77	1.47	0.00	176.1	93.6	30.2								
3.90	1.73	0.49	37.0	20.00	20.0	0.18	0.18	0.75	0.78	1.00	0.58	0.58	0.76
0.76	1.47	0.00	176.1	93.7	30.2								
3.84	1.73	0.48	37.0	20.00	20.0	0.18	0.18	0.75	0.78	1.00	0.58	0.58	0.76
0.76	1.48	0.00	176.2	93.8	30.2								
3.78	1.73	0.48	37.0	20.00	20.0	0.17	0.17	0.75	0.78	1.00	0.58	0.58	0.76
0.76	1.48	0.00	176.3	93.9	30.3								
3.72	1.73	0.47	37.0	20.00	20.0	0.17	0.17	0.75	0.78	1.00	0.58	0.58	0.76
0.76	1.48	0.00	176.4	94.0	30.3								
3.67	1.73	0.46	37.0	20.00	20.0	0.17	0.17	0.75	0.78	1.00	0.58	0.58	0.75
0.75	1.49	0.00	176.5	94.0	30.3								
3.61	1.73	0.45	37.0	20.00	20.0	0.17	0.17	0.75	0.78	1.00	0.58	0.58	0.75
0.75	1.49	0.00	176.5	94.1	30.3								
3.55	1.73	0.45	37.0	20.00	20.0	0.16	0.16	0.75	0.78	1.00	0.58	0.58	0.75
0.75	1.49	0.00	176.6	94.2	30.3								
3.49	1.73	0.44	37.0	20.00	20.0	0.16	0.16	0.75	0.78	1.00	0.58	0.58	0.74
0.74	1.50	0.00	176.7	94.3	30.4								
3.43	1.73	0.43	37.0	20.00	20.0	0.16	0.16	0.75	0.78	1.00	0.58	0.58	0.74
0.74	1.50	0.00	176.8	94.4	30.4								
3.37	1.73	0.42	37.0	20.00	20.0	0.15	0.15	0.75	0.78	1.00	0.58	0.58	0.74
0.74	1.50	0.00	176.8	94.4	30.4								
3.31	1.73	0.42	37.0	20.00	20.0	0.15	0.15	0.75	0.78	1.00	0.58	0.58	0.74
0.74	1.51	0.00	176.9	94.5	30.4								
3.25	1.73	0.41	37.0	20.00	20.0	0.15	0.15	0.75	0.78	1.00	0.58	0.58	0.73
0.73	1.51	0.00	177.0	94.6	30.4								
3.19	1.73	0.40	37.0	20.00	20.0	0.15	0.15	0.75	0.78	1.00	0.58	0.58	0.73
0.73	1.51	0.00	177.1	94.7	30.5								
3.13	1.73	0.40	37.0	20.00	20.0	0.14	0.14	0.75	0.78	1.00	0.58	0.58	0.73
0.73	1.52	0.00	177.1	94.8	30.5								
3.07	1.73	0.39	37.0	20.00	20.0	0.14	0.14	0.75	0.78	1.00	0.58	0.58	0.73
0.73	1.52	0.00	177.2	94.8	30.5								
3.02	1.73	0.38	37.0	20.00	20.0	0.14	0.14	0.75	0.78	1.00	0.58	0.58	0.72
0.72	1.52	0.00	177.3	94.9	30.5								
2.96	1.73	0.37	37.0	20.00	20.0	0.14	0.14	0.75	0.78	1.00	0.58	0.58	0.72
0.72	1.53	0.00	177.4	95.0	30.6								
2.90	1.73	0.37	37.0	20.00	20.0	0.13	0.13	0.75	0.78	1.00	0.58	0.58	0.72
0.72	1.53	0.00	177.4	95.1	30.6								
2.84	1.73	0.36	37.0	20.00	20.0	0.13	0.13	0.75	0.78	1.00	0.58	0.58	0.71
0.71	1.53	0.00	177.5	95.1	30.6								
2.78	1.73	0.35	37.0	20.00	20.0	0.13	0.13	0.75	0.78	1.00	0.58	0.58	0.71
0.71	1.54	0.00	177.6	95.2	30.6								
2.72	1.73	0.34	37.0	20.00	20.0	0.13	0.13	0.75	0.78	1.00	0.58	0.58	0.71
0.71	1.54	0.00	177.7	95.3	30.6								
2.66	1.73	0.34	37.0	20.00	20.0	0.12	0.12	0.75	0.78	1.00	0.58	0.58	0.71
0.71	1.54	0.00	177.7	95.4	30.7								
2.60	1.73	0.33	37.0	20.00	20.0	0.12	0.12	0.75	0.78	1.00	0.58	0.58	0.70
0.70	1.55	0.00	177.8	95.4	30.7								
2.54	1.73	0.32	37.0	20.00	20.0	0.12	0.12	0.75	0.78	1.00	0.58	0.58	0.70
0.70	1.55	0.00	177.9	95.5	30.7								
2.48	1.73	0.31	37.0	20.00	20.0	0.11	0.11	0.75	0.78	1.00	0.58	0.58	0.70
0.70	1.55	0.00	177.9	95.6	30.7								
2.42	1.73	0.31	37.0	20.00	20.0	0.11	0.11	0.75	0.78	1.00	0.58	0.58	0.70
0.70	1.56	0.00	178.0	95.7	30.7								
2.36	1.73	0.30	37.0	20.00	20.0	0.11	0.11	0.75	0.78	1.00	0.58	0.58	0.69
0.69	1.56	0.00	178.1	95.7	30.8								
2.31	1.73	0.29	37.0	20.00	20.0	0.11	0.11	0.75	0.78	1.00	0.58	0.58	0.69
0.69	1.56	0.00	178.2	95.8	30.8								
2.25	1.73	0.28	37.0	20.00	20.0	0.10	0.10	0.75	0.78	1.00	0.58	0.58	0.69
0.69	1.57	0.00	178.2	95.9	30.8								
2.19	1.73	0.28	37.0	20.00	20.0	0.10	0.10	0.75	0.78	1.00	0.58	0.58	0.69
0.69	1.57	0.00	178.3	96.0	30.8								
2.13	1.73	0.27	37.0	20.00	20.0	0.10	0.10	0.75	0.78	1.00	0.58	0.58	0.68
0.68	1.57	0.00	178.4	96.0	30.8								
2.07	1.73	0.26	37.0	20.00	20.0	0.10	0.10	0.75	0.78	1.00	0.58	0.58	0.68
0.68	1.58	0.00	178.4	96.1	30.8								
2.01	1.73	0.25	37.0	20.00	20.0	0.09	0.09	0.75	0.78	1.00	0.58	0.58	0.68
0.68	1.58	0.00	178.5	96.2	30.9								

													0detail
1.95	1.73	0.25	37.0	20.00	20.0	0.09	0.09	0.75	0.78	1.00	0.58	0.58	0.67
0.67	1.58	0.00	178.6	96.3	30.9								
1.89	1.73	0.24	37.0	20.00	20.0	0.09	0.09	0.75	0.78	1.00	0.58	0.58	0.67
0.67	1.59	0.00	178.6	96.3	30.9								
1.83	1.73	0.23	37.0	20.00	20.0	0.08	0.08	0.75	0.78	1.00	0.58	0.58	0.67
0.67	1.59	0.00	178.7	96.4	30.9								
1.77	1.73	0.23	37.0	20.00	20.0	0.08	0.08	0.75	0.78	1.00	0.58	0.58	0.67
0.67	1.59	0.00	178.8	96.5	30.9								
1.71	1.73	0.22	37.0	20.00	20.0	0.08	0.08	0.75	0.78	1.00	0.58	0.58	0.66
0.66	1.60	0.00	178.8	96.5	31.0								
1.66	1.73	0.21	37.0	20.00	20.0	0.08	0.08	0.75	0.78	1.00	0.58	0.58	0.66
0.66	1.60	0.00	178.9	96.6	31.0								
1.60	1.73	0.20	37.0	20.00	20.0	0.07	0.07	0.75	0.78	1.00	0.58	0.58	0.66
0.66	1.60	0.00	179.0	96.7	31.0								
1.54	1.73	0.20	37.0	20.00	20.0	0.07	0.07	0.75	0.78	1.00	0.58	0.58	0.66
0.66	1.61	0.00	179.0	96.8	31.0								
1.48	1.73	0.19	37.0	20.00	20.0	0.07	0.07	0.75	0.78	1.00	0.58	0.58	0.65
0.65	1.61	0.00	179.1	96.8	31.0								
1.42	1.73	0.18	37.0	20.00	20.0	0.07	0.07	0.75	0.78	1.00	0.58	0.58	0.65
0.65	1.61	0.00	179.2	96.9	31.1								
1.36	1.73	0.17	37.0	20.00	20.0	0.06	0.06	0.75	0.78	1.00	0.58	0.58	0.65
0.65	1.62	0.00	179.2	97.0	31.1								
1.30	1.73	0.17	37.0	20.00	20.0	0.06	0.06	0.75	0.78	1.00	0.58	0.58	0.64
0.64	1.62	0.00	179.3	97.0	31.1								
1.24	1.73	0.16	37.0	20.00	20.0	0.06	0.06	0.75	0.78	1.00	0.58	0.58	0.64
0.64	1.62	0.00	179.4	97.1	31.1								
1.18	1.73	0.15	37.0	20.00	20.0	0.06	0.06	0.75	0.78	1.00	0.58	0.58	0.64
0.64	1.63	0.00	179.4	97.2	31.1								
1.12	1.73	0.14	37.0	20.00	20.0	0.05	0.05	0.75	0.78	1.00	0.58	0.58	0.64
0.64	1.63	0.00	179.5	97.2	31.1								
1.06	1.73	0.14	37.0	20.00	20.0	0.05	0.05	0.75	0.78	1.00	0.58	0.58	0.63
0.63	1.63	0.00	179.6	97.3	31.2								
1.01	1.73	0.13	37.0	20.00	20.0	0.05	0.05	0.75	0.78	1.00	0.58	0.58	0.63
0.63	1.64	0.00	179.6	97.4	31.2								
0.95	1.73	0.12	37.0	20.00	20.0	0.04	0.04	0.75	0.78	1.00	0.58	0.58	0.63
0.63	1.64	0.00	179.7	97.5	31.2								
0.89	1.73	0.11	37.0	20.00	20.0	0.04	0.04	0.75	0.78	1.00	0.58	0.58	0.63
0.63	1.64	0.00	179.8	97.5	31.2								
0.83	1.73	0.11	37.0	20.00	20.0	0.04	0.04	0.75	0.78	1.00	0.58	0.58	0.62
0.62	1.65	0.00	179.8	97.6	31.2								
0.77	1.73	0.10	37.0	20.00	20.0	0.04	0.04	0.75	0.78	1.00	0.58	0.58	0.62
0.62	1.65	0.00	179.9	97.7	31.3								
0.71	1.73	0.09	37.0	20.00	20.0	0.03	0.03	0.75	0.78	1.00	0.58	0.58	0.62
0.62	1.65	0.00	180.0	97.7	31.3								
0.65	1.73	0.08	37.0	20.00	20.0	0.03	0.03	0.75	0.78	1.00	0.58	0.58	0.62
0.62	1.66	0.00	180.0	97.8	31.3								
0.59	1.73	0.08	37.0	20.00	20.0	0.03	0.03	0.75	0.78	1.00	0.58	0.58	0.61
0.61	1.66	0.00	180.1	97.9	31.3								
0.53	1.73	0.07	37.0	20.00	20.0	0.03	0.03	0.75	0.78	1.00	0.58	0.58	0.61
0.61	1.66	0.00	180.1	97.9	31.3								
0.47	1.73	0.06	37.0	20.00	20.0	0.02	0.02	0.75	0.78	1.00	0.58	0.58	0.61
0.61	1.67	0.00	180.2	98.0	31.3								
0.41	1.73	0.06	37.0	20.00	20.0	0.02	0.02	0.75	0.78	1.00	0.58	0.58	0.60
0.60	1.67	0.00	180.3	98.0	31.4								
0.35	1.73	0.05	37.0	20.00	20.0	0.02	0.02	0.75	0.78	1.00	0.58	0.58	0.60
0.60	1.67	0.00	180.3	98.1	31.4								
0.30	1.73	0.04	37.0	20.00	20.0	0.01	0.01	0.75	0.78	1.00	0.58	0.58	0.60
0.60	1.68	0.00	180.4	98.2	31.4								
0.24	1.73	0.03	37.0	20.00	20.0	0.01	0.01	0.75	0.78	1.00	0.58	0.58	0.60
0.60	1.68	0.00	180.5	98.2	31.4								
0.18	1.73	0.03	37.0	20.00	20.0	0.01	0.01	0.75	0.78	1.00	0.58	0.58	0.59
0.59	1.68	0.00	180.5	98.3	31.4								
0.12	1.73	0.02	37.0	20.00	20.0	0.01	0.01	0.75	0.78	1.00	0.58	0.58	0.59
0.59	1.69	0.00	180.6	98.4	31.4								
0.06	1.73	0.01	37.0	20.00	20.0	0.00	0.00	0.75	0.78	1.00	0.58	0.58	0.59
0.59	1.69	0.00	180.6	98.4	31.5								
0.00	1.73	0.00	37.0	20.00	20.0	0.00	0.00	0.75	0.78	1.00	0.58	0.58	0.59

Ødetail

0.59 1.72 0.00 180.7 98.5 31.5

SETTLEMENT based on Ultimate Loading by Vesic Method (1977):

Ztip=29.50 Btip= 0.67 Cp= 0.030 Cs= 0.060
 Xpp=0.189-in Xps= 0.010-in Xtip= 0.198-in
 Cp & Cs are average value at bearing stratum from pile tip extend to 10 Btip

At loading: Qtip=83.9-kp Qtop= 180.7-kp Qside= 96.8-kp
 Xtip=0.198-in Xtop= 0.400-in Xshaft= 0.201-in

LOAD - TOTAL SETTLEMENT RELATION (from t-z, and q-w curves):

Based on Vesic Method (1977)

Xtop -in	Xshaft -in	Xtip -in	Qtip -kp	Qside -kp	Qtotal -kp
0.0005	0.0005	0.0000	0.1	0.5	0.6
0.0310	0.0285	0.0025	2.4	31.8	34.1
0.0435	0.0398	0.0037	3.5	43.9	47.5
0.0545	0.0495	0.0050	4.7	54.2	58.9
0.0642	0.0580	0.0062	5.8	62.8	68.6
0.0727	0.0652	0.0074	6.9	69.9	76.8
0.0802	0.0715	0.0087	8.1	75.8	83.8
0.0868	0.0769	0.0099	9.2	80.5	89.7
0.0927	0.0816	0.0112	10.3	84.4	94.7
0.0980	0.0856	0.0124	11.4	87.4	98.9
0.1028	0.0892	0.0136	12.6	89.9	102.4
0.1072	0.0923	0.0149	13.7	91.8	105.4
0.1112	0.0951	0.0161	14.8	93.2	108.0
0.1149	0.0975	0.0174	15.9	94.3	110.2
0.1184	0.0998	0.0186	17.0	95.1	112.1
0.1217	0.1018	0.0198	18.1	95.7	113.8
0.1248	0.1037	0.0211	19.1	96.1	115.3
0.1278	0.1055	0.0223	20.2	96.4	116.6
0.1308	0.1072	0.0236	21.3	96.6	117.9
0.1336	0.1088	0.0248	22.3	96.7	119.0
0.1364	0.1104	0.0260	23.4	96.8	120.1
0.1392	0.1119	0.0273	24.4	96.8	121.2
0.1419	0.1134	0.0285	25.4	96.8	122.2
0.1446	0.1148	0.0298	26.4	96.7	123.1
0.1472	0.1162	0.0310	27.4	96.7	124.1
0.1498	0.1176	0.0322	28.4	96.6	124.9
0.1524	0.1189	0.0335	29.4	96.4	125.8
0.1549	0.1201	0.0347	30.3	96.2	126.6
0.1573	0.1214	0.0360	31.3	96.0	127.3
0.1597	0.1225	0.0372	32.2	95.8	128.0
0.1621	0.1236	0.0384	33.1	95.5	128.6
0.1644	0.1247	0.0397	34.1	95.1	129.2
0.1666	0.1257	0.0409	35.0	94.7	129.7
0.1688	0.1267	0.0422	35.8	94.3	130.1
0.1710	0.1276	0.0434	36.7	93.8	130.6
0.1731	0.1285	0.0446	37.6	93.4	131.0
0.1753	0.1294	0.0459	38.4	93.0	131.4
0.1774	0.1303	0.0471	39.3	92.6	131.8
0.1796	0.1313	0.0484	40.1	92.2	132.3
0.1822	0.1326	0.0496	40.9	92.4	133.3
0.1845	0.1337	0.0508	41.7	92.3	134.0
0.1868	0.1347	0.0521	42.5	92.2	134.7
0.1891	0.1358	0.0533	43.3	92.1	135.4
0.1914	0.1368	0.0546	44.0	92.0	136.0
0.1937	0.1378	0.0558	44.8	91.9	136.7
0.1959	0.1388	0.0571	45.5	91.8	137.3
0.1981	0.1398	0.0583	46.3	91.6	137.9
0.2003	0.1407	0.0595	47.0	91.5	138.5
0.2024	0.1417	0.0608	47.7	91.4	139.1
0.2046	0.1426	0.0620	48.4	91.2	139.6
0.2067	0.1434	0.0633	49.0	91.1	140.1
0.2088	0.1443	0.0645	49.7	90.9	140.7

Ødetail

0.2109	0.1451	0.0657	50.4	90.8	141.2
0.2129	0.1459	0.0670	51.0	90.6	141.6
0.2149	0.1467	0.0682	51.6	90.5	142.1
0.2170	0.1475	0.0695	52.3	90.3	142.6
0.2190	0.1483	0.0707	52.9	90.1	143.0
0.2209	0.1490	0.0719	53.5	90.0	143.5
0.2229	0.1497	0.0732	54.1	89.8	143.9
0.2249	0.1505	0.0744	54.6	89.7	144.3
0.2268	0.1512	0.0757	55.2	89.5	144.7
0.2288	0.1519	0.0769	55.8	89.3	145.1
0.2307	0.1526	0.0781	56.3	89.2	145.5
0.2326	0.1532	0.0794	56.9	89.1	145.9
0.2345	0.1539	0.0806	57.4	88.9	146.3
0.2364	0.1546	0.0819	57.9	88.8	146.7
0.2383	0.1552	0.0831	58.4	88.7	147.1
0.2402	0.1559	0.0843	58.9	88.6	147.5
0.2421	0.1565	0.0856	59.4	88.5	147.9
0.2440	0.1571	0.0868	59.9	88.4	148.3
0.2458	0.1578	0.0881	60.4	88.3	148.7
0.2477	0.1584	0.0893	60.8	88.2	149.0
0.2495	0.1590	0.0905	61.3	88.1	149.4
0.2513	0.1595	0.0918	61.8	88.0	149.7
0.2531	0.1601	0.0930	62.2	87.9	150.1
0.2549	0.1606	0.0943	62.6	87.7	150.4
0.2566	0.1611	0.0955	63.1	87.6	150.6
0.2583	0.1616	0.0967	63.5	87.4	150.9
0.2600	0.1620	0.0980	63.9	87.1	151.0
0.2618	0.1626	0.0992	64.3	87.1	151.4
0.2636	0.1631	0.1005	64.7	87.0	151.7
0.2653	0.1636	0.1017	65.1	86.9	152.0
0.2671	0.1641	0.1029	65.5	86.8	152.4
0.2688	0.1646	0.1042	65.9	86.8	152.7
0.2705	0.1651	0.1054	66.3	86.7	153.0
0.2722	0.1656	0.1067	66.7	86.6	153.2
0.2740	0.1661	0.1079	67.0	86.5	153.5
0.2757	0.1665	0.1091	67.4	86.4	153.8
0.2774	0.1670	0.1104	67.7	86.3	154.1
0.2791	0.1674	0.1116	68.1	86.3	154.4
0.2807	0.1679	0.1129	68.4	86.2	154.6
0.2824	0.1683	0.1141	68.8	86.1	154.9
0.2841	0.1687	0.1153	69.1	86.0	155.1
0.2858	0.1692	0.1166	69.5	85.9	155.4
0.2956	0.1716	0.1240	71.4	85.4	156.8
0.3273	0.1784	0.1488	77.0	83.8	160.7
0.3571	0.1835	0.1736	81.4	82.1	163.4
0.3843	0.1859	0.1984	83.9	80.4	164.3
0.4073	0.1841	0.2232	83.5	78.7	162.3
0.4253	0.1772	0.2480	79.8	77.1	156.8

At Qwork= 100.00-kp Settlement= 0.09954-in
 At Qwork= 100.00-kp Secant Stiffness Kqx= 1004.60-kp/-in
 At Xallow= 1.00-in Q= 99999.00-kp

Note: If the program cannot find a result or the result exceeds the upper limit. The result will be displayed as 99999.

SUMMARY:

Total Ultimate Capacity (Down)= 180.699-kp Total Ultimate Capacity (Up)= 98.525-kp
 Total Allowable Capacity (Down)= 106.484-kp Total Allowable Capacity (Up)= 50.123-kp

Weight above Ground= 0.03 Total Pile Weight= 1.72-kp *Soil Weight is not included
 Side Resistance (Down)= 96.806-kp Side Resistance (Up)= 96.805-kp
 Tip Resistance (Down)= 83.893-kp Tip Resistance (Up)= 0.000-kp
 Negative Friction, Qneg= 0.000-kp, which has been subtracted from Total Ultimate Capacity (Down)
 Negative friction does not affect Total Uplift Ultimate Capacity (Up)

OK! Qallow > Q * Vertical Load, Q= 100.0 -kp

Ødetail

FACTOR OF SAFETY:

F_Sside F_Stip F_Sup F_Sweight

1.5 2.0 2.0 1.0

* F_Storsion = F_Sside

Notes:

* Settlement in the program is Elastic Settlement only. Consolidation Settlement is not calculated!

Length - Pile length, distance from pile top to tip (not from ground surface)

Width or D - Width of pile shaft (pile diameter)

D_s and D_l - Short Side and Long Side of Footing

Area - Section area of pile shaft or tip area of pile

S_v - Vertical stress in soils (It may be limited based on critical depth, Z_{lim} or Z/D)

q_{ult} - Ultimate tip resistance (pressure)

Q_{tip_dw} - Ultimate downward tip resistance (Force or Capacity)

Q_{tip_up} - Ultimate uplift tip resistance for belled pile or uplift plate (Force or Capacity)

Torsion - Ultimate torsion resistance for single pile (Capacity)

dz - Small Segment of Depth for Calculation

Z_s - Soil Depth, Depth from ground surface

Z_p - Pile Depth, Depth from pile top

Prem - Primer of pile shaft

Phi - Soil internal friction angle (between soils)

Kf - Friction factor to convert Phi to Delta

Delta - Ski friction between soil and pile (function of Phi. It is different from Phi)

f_{dw} - Downward Resistance between soil and pile from Delta

f_{up} - Uplift Resistance between soil and pile from Delta

C - Soil cohesion (between soils)

Ca - Adhesion between soil and pile (function of C. It is different from C) Ca=KaKcC

Ka - Adhesion ratio, C/Ca

Kc - Adhesion factor defended by users

Ca_{dw} - Downward adhesion between pile and soil

Ca_{up} - Uplift adhesion between pile and soil

Sf_{dw} - Downward side resistance (sum of friction and adhesion, f_{dw} + Ca_{dw})

Sf_{up} - Uplift side resistance (sum of friction and adhesion, f_{up} + Ca_{up})

Torsion side resistance = (Sf_{dw}+Sf_{up})/2 * pile diameter/2

Weight - Weight of Pile shaft

Q_{neg} - negative friction Resistance

Q_{side} - Ultimate side resistance (Q_{side_dw} or Q_{side_up})

Q_{tip} - Ultimate tip resistance (Q_{tip_dw} or Q_{tip_up} for uplift plate)

Q_{dw} - Ultimate downward capacity (Q_{tip} + Q_{side_dw})

Q_{up} - Ultimate uplift capacity (Weight + Q_{side_up})

E - Elastic modules

X_s - Settlement due to axial deformation of pile shaft

X_{pp} - Settlement due to point load from pile tip

X_{ps} - Settlement due to load from pile shaft

X_{top} - Total settlement, X_s + X_{pp} + X_{ps}

X_{tip} - Tip settlement, X_{pp} + X_{ps}

X_{shaft} - Shaft deformation, X_s

X_{allow} - Allowable settlement specified by users

Q_{work} - Vertical working load applied to pile

Q_{allow} - Vertical allowable load, Q_{ult}/F.S.

SOIL STRESS, SIDE RESISTANCE, & AXIAL FORCE vs DEPTH Based on Ultimate Load Condition

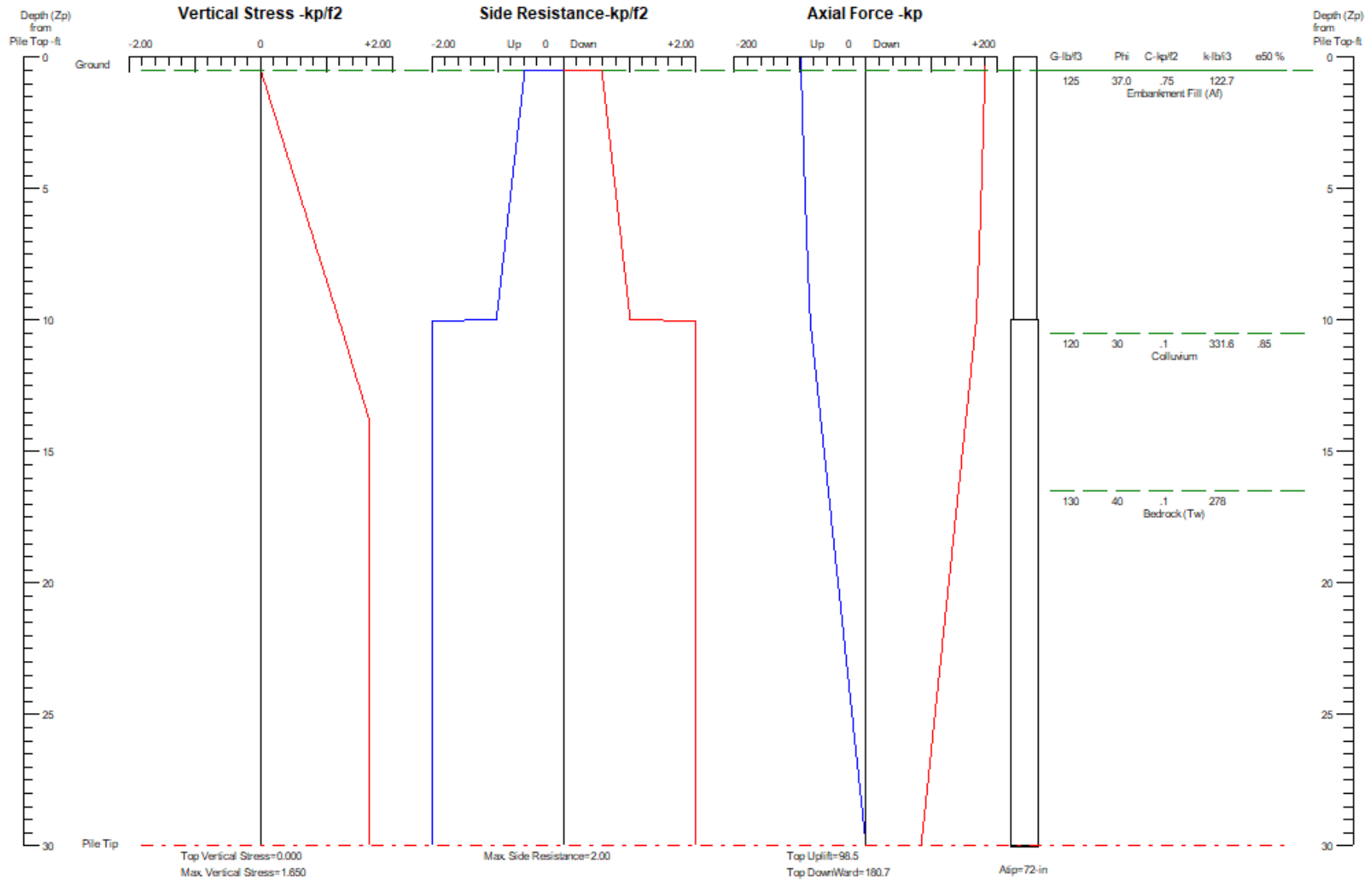

Ødetail

Depth vs. Soil Stress, Side Resistance, and Pile Axial Force:

Zp -ft	Sv -kp/f2	Sf_dw -kp/f2	Sf_up -kp/f2	Q_dw -kp	Q_up -kp
0.0	0.00	0.00	0.00	180.7	98.5
0.5	0.00	0.00	0.00	180.7	98.5
0.5	0.00	0.59	0.59	180.7	98.5
0.6	0.01	0.59	0.59	180.6	98.4
0.6	0.02	0.59	0.59	180.6	98.4
0.7	0.03	0.59	0.59	180.5	98.3
0.7	0.03	0.60	0.60	180.5	98.2
0.8	0.04	0.60	0.60	180.4	98.2
0.9	0.05	0.60	0.60	180.3	98.1
0.9	0.06	0.60	0.60	180.3	98.0
1.0	0.06	0.61	0.61	180.2	98.0
1.0	0.07	0.61	0.61	180.1	97.9
1.1	0.08	0.61	0.61	180.1	97.9
1.2	0.08	0.62	0.62	180.0	97.8
1.2	0.09	0.62	0.62	180.0	97.7
1.3	0.10	0.62	0.62	179.9	97.7
1.3	0.11	0.62	0.62	179.8	97.6
1.4	0.11	0.63	0.63	179.8	97.5
1.4	0.12	0.63	0.63	179.7	97.5
1.5	0.13	0.63	0.63	179.6	97.4
1.6	0.14	0.63	0.63	179.6	97.3
1.6	0.14	0.64	0.64	179.5	97.2
1.7	0.15	0.64	0.64	179.4	97.2
1.7	0.16	0.64	0.64	179.4	97.1
1.8	0.17	0.64	0.64	179.3	97.0
1.9	0.17	0.65	0.65	179.2	97.0
1.9	0.18	0.65	0.65	179.2	96.9
2.0	0.19	0.65	0.65	179.1	96.8
2.0	0.20	0.66	0.66	179.0	96.8
2.1	0.20	0.66	0.66	179.0	96.7
2.2	0.21	0.66	0.66	178.9	96.6
2.2	0.22	0.66	0.66	178.8	96.5
2.3	0.23	0.67	0.67	178.8	96.5
2.3	0.23	0.67	0.67	178.7	96.4
2.4	0.24	0.67	0.67	178.6	96.3
2.5	0.25	0.67	0.67	178.6	96.3
2.5	0.25	0.68	0.68	178.5	96.2
2.6	0.26	0.68	0.68	178.4	96.1
2.6	0.27	0.68	0.68	178.4	96.0
2.7	0.28	0.69	0.69	178.3	96.0
2.7	0.28	0.69	0.69	178.2	95.9
2.8	0.29	0.69	0.69	178.2	95.8
2.9	0.30	0.69	0.69	178.1	95.7
2.9	0.31	0.70	0.70	178.0	95.7
3.0	0.31	0.70	0.70	177.9	95.6
3.0	0.32	0.70	0.70	177.9	95.5
3.1	0.33	0.70	0.70	177.8	95.4
3.2	0.34	0.71	0.71	177.7	95.4
3.2	0.34	0.71	0.71	177.7	95.3
3.3	0.35	0.71	0.71	177.6	95.2
3.3	0.36	0.71	0.71	177.5	95.1
3.4	0.37	0.72	0.72	177.4	95.1
3.5	0.37	0.72	0.72	177.4	95.0
3.5	0.38	0.72	0.72	177.3	94.9
3.6	0.39	0.73	0.73	177.2	94.8
3.6	0.40	0.73	0.73	177.1	94.8
3.7	0.40	0.73	0.73	177.1	94.7
3.8	0.41	0.73	0.73	177.0	94.6

Ødetail

3.8	0.42	0.74	0.74	176.9	94.5
3.9	0.42	0.74	0.74	176.8	94.4
3.9	0.43	0.74	0.74	176.8	94.4
4.0	0.44	0.74	0.74	176.7	94.3
4.0	0.45	0.75	0.75	176.6	94.2
4.1	0.45	0.75	0.75	176.5	94.1
4.2	0.46	0.75	0.75	176.5	94.0
4.2	0.47	0.76	0.76	176.4	94.0
4.3	0.48	0.76	0.76	176.3	93.9
4.3	0.48	0.76	0.76	176.2	93.8
4.4	0.49	0.76	0.76	176.1	93.7
4.5	0.50	0.77	0.77	176.1	93.6
4.5	0.51	0.77	0.77	176.0	93.6
4.6	0.51	0.77	0.77	175.9	93.5
4.6	0.52	0.77	0.77	175.8	93.4
4.7	0.53	0.78	0.78	175.8	93.3
4.8	0.54	0.78	0.78	175.7	93.2
4.8	0.54	0.78	0.78	175.6	93.1
4.9	0.55	0.78	0.78	175.5	93.1
4.9	0.56	0.79	0.79	175.4	93.0
5.0	0.57	0.79	0.79	175.4	92.9
5.1	0.57	0.79	0.79	175.3	92.8
5.1	0.58	0.80	0.80	175.2	92.7
5.2	0.59	0.80	0.80	175.1	92.6
5.2	0.59	0.80	0.80	175.0	92.6
5.3	0.60	0.80	0.80	174.9	92.5
5.3	0.61	0.81	0.81	174.9	92.4
5.4	0.62	0.81	0.81	174.8	92.3
5.5	0.62	0.81	0.81	174.7	92.2
5.5	0.63	0.81	0.81	174.6	92.1
5.6	0.64	0.82	0.82	174.5	92.0
5.6	0.65	0.82	0.82	174.4	92.0
5.7	0.65	0.82	0.82	174.4	91.9
5.8	0.66	0.83	0.83	174.3	91.8
5.8	0.67	0.83	0.83	174.2	91.7
5.9	0.68	0.83	0.83	174.1	91.6
5.9	0.68	0.83	0.83	174.0	91.5
6.0	0.69	0.84	0.84	173.9	91.4
6.1	0.70	0.84	0.84	173.9	91.3
6.1	0.71	0.84	0.84	173.8	91.2
6.2	0.71	0.84	0.84	173.7	91.2
6.2	0.72	0.85	0.85	173.6	91.1
6.3	0.73	0.85	0.85	173.5	91.0
6.4	0.74	0.85	0.85	173.4	90.9
6.4	0.74	0.85	0.85	173.3	90.8
6.5	0.75	0.86	0.86	173.2	90.7
6.5	0.76	0.86	0.86	173.2	90.6
6.6	0.76	0.86	0.86	173.1	90.5
6.6	0.77	0.87	0.87	173.0	90.4
6.7	0.78	0.87	0.87	172.9	90.3
6.8	0.79	0.87	0.87	172.8	90.2
6.8	0.79	0.87	0.87	172.7	90.2
6.9	0.80	0.88	0.88	172.6	90.1
6.9	0.81	0.88	0.88	172.5	90.0
7.0	0.82	0.88	0.88	172.4	89.9
7.1	0.82	0.88	0.88	172.4	89.8
7.1	0.83	0.89	0.89	172.3	89.7
7.2	0.84	0.89	0.89	172.2	89.6
7.2	0.85	0.89	0.89	172.1	89.5
7.3	0.85	0.90	0.90	172.0	89.4
7.4	0.86	0.90	0.90	171.9	89.3
7.4	0.87	0.90	0.90	171.8	89.2
7.5	0.88	0.90	0.90	171.7	89.1
7.5	0.88	0.91	0.91	171.6	89.0
7.6	0.89	0.91	0.91	171.5	88.9
7.7	0.90	0.91	0.91	171.4	88.8
7.7	0.91	0.91	0.91	171.3	88.7

Ødetail

7.8	0.91	0.92	0.92	171.2	88.6
7.8	0.92	0.92	0.92	171.2	88.5
7.9	0.93	0.92	0.92	171.1	88.4
7.9	0.93	0.92	0.92	171.0	88.3
8.0	0.94	0.93	0.93	170.9	88.2
8.1	0.95	0.93	0.93	170.8	88.1
8.1	0.96	0.93	0.93	170.7	88.1
8.2	0.96	0.94	0.94	170.6	88.0
8.2	0.97	0.94	0.94	170.5	87.9
8.3	0.98	0.94	0.94	170.4	87.8
8.4	0.99	0.94	0.94	170.3	87.7
8.4	0.99	0.95	0.95	170.2	87.6
8.5	1.00	0.95	0.95	170.1	87.5
8.5	1.01	0.95	0.95	170.0	87.4
8.6	1.02	0.95	0.95	169.9	87.3
8.7	1.02	0.96	0.96	169.8	87.2
8.7	1.03	0.96	0.96	169.7	87.1
8.8	1.04	0.96	0.96	169.6	86.9
8.8	1.05	0.97	0.97	169.5	86.8
8.9	1.05	0.97	0.97	169.4	86.7
9.0	1.06	0.97	0.97	169.3	86.6
9.0	1.07	0.97	0.97	169.2	86.5
9.1	1.08	0.98	0.98	169.1	86.4
9.1	1.08	0.98	0.98	169.0	86.3
9.2	1.09	0.98	0.98	168.9	86.2
9.2	1.10	0.98	0.98	168.8	86.1
9.3	1.10	0.99	0.99	168.7	86.0
9.4	1.11	0.99	0.99	168.6	85.9
9.4	1.12	0.99	0.99	168.5	85.8
9.5	1.13	0.99	0.99	168.4	85.7
9.5	1.13	1.00	1.00	168.3	85.6
9.6	1.14	1.00	1.00	168.2	85.5
9.7	1.15	1.00	1.00	168.1	85.4
9.7	1.16	1.01	1.01	168.0	85.3
9.8	1.16	1.01	1.01	167.9	85.2
9.8	1.17	1.01	1.01	167.8	85.1
9.9	1.18	1.01	1.01	167.7	85.0
10.0	1.19	1.02	1.02	167.6	84.9
10.0	1.19	2.00	2.00	167.5	84.8
10.1	1.20	2.00	2.00	167.2	84.5
10.1	1.21	2.00	2.00	167.0	84.2
10.2	1.22	2.00	2.00	166.7	84.0
10.3	1.22	2.00	2.00	166.5	83.7
10.3	1.23	2.00	2.00	166.2	83.5
10.4	1.24	2.00	2.00	166.0	83.2
10.4	1.25	2.00	2.00	165.8	83.0
10.5	1.25	2.00	2.00	165.5	82.7
10.6	1.26	2.00	2.00	165.3	82.5
10.6	1.27	2.00	2.00	165.0	82.2
10.7	1.27	2.00	2.00	164.8	82.0
10.7	1.28	2.00	2.00	164.5	81.7
10.8	1.29	2.00	2.00	164.3	81.5
10.8	1.30	2.00	2.00	164.0	81.2
10.9	1.30	2.00	2.00	163.8	81.0
11.0	1.31	2.00	2.00	163.5	80.7
11.0	1.32	2.00	2.00	163.3	80.5
11.1	1.32	2.00	2.00	163.0	80.2
11.1	1.33	2.00	2.00	162.8	80.0
11.2	1.34	2.00	2.00	162.5	79.7
11.3	1.35	2.00	2.00	162.3	79.5
11.3	1.35	2.00	2.00	162.0	79.2
11.4	1.36	2.00	2.00	161.8	79.0
11.4	1.37	2.00	2.00	161.5	78.7
11.5	1.37	2.00	2.00	161.3	78.5
11.6	1.38	2.00	2.00	161.1	78.2
11.6	1.39	2.00	2.00	160.8	78.0
11.7	1.39	2.00	2.00	160.6	77.7

Ødetail

11.7	1.40	2.00	2.00	160.3	77.5
11.8	1.41	2.00	2.00	160.1	77.2
11.9	1.42	2.00	2.00	159.8	77.0
11.9	1.42	2.00	2.00	159.6	76.7
12.0	1.43	2.00	2.00	159.3	76.5
12.0	1.44	2.00	2.00	159.1	76.2
12.1	1.44	2.00	2.00	158.8	76.0
12.1	1.45	2.00	2.00	158.6	75.7
12.2	1.46	2.00	2.00	158.3	75.5
12.3	1.47	2.00	2.00	158.1	75.2
12.3	1.47	2.00	2.00	157.8	75.0
12.4	1.48	2.00	2.00	157.6	74.7
12.4	1.49	2.00	2.00	157.3	74.5
12.5	1.49	2.00	2.00	157.1	74.2
12.6	1.50	2.00	2.00	156.9	74.0
12.6	1.51	2.00	2.00	156.6	73.7
12.7	1.52	2.00	2.00	156.4	73.5
12.7	1.52	2.00	2.00	156.1	73.2
12.8	1.53	2.00	2.00	155.9	73.0
12.9	1.54	2.00	2.00	155.6	72.7
12.9	1.54	2.00	2.00	155.4	72.5
13.0	1.55	2.00	2.00	155.1	72.2
13.0	1.56	2.00	2.00	154.9	72.0
13.1	1.57	2.00	2.00	154.6	71.7
13.2	1.57	2.00	2.00	154.4	71.5
13.2	1.58	2.00	2.00	154.1	71.2
13.3	1.59	2.00	2.00	153.9	71.0
13.3	1.59	2.00	2.00	153.6	70.7
13.4	1.60	2.00	2.00	153.4	70.5
13.4	1.61	2.00	2.00	153.1	70.2
13.5	1.61	2.00	2.00	152.9	70.0
13.6	1.62	2.00	2.00	152.6	69.7
13.6	1.63	2.00	2.00	152.4	69.5
13.7	1.64	2.00	2.00	152.2	69.2
13.7	1.64	2.00	2.00	151.9	69.0
13.8	1.65	2.00	2.00	151.7	68.7
13.9	1.65	2.00	2.00	151.4	68.5
13.9	1.65	2.00	2.00	151.2	68.2
14.0	1.65	2.00	2.00	150.9	68.0
14.0	1.65	2.00	2.00	150.7	67.7
14.1	1.65	2.00	2.00	150.4	67.4
14.2	1.65	2.00	2.00	150.2	67.2
14.2	1.65	2.00	2.00	149.9	66.9
14.3	1.65	2.00	2.00	149.7	66.7
14.3	1.65	2.00	2.00	149.4	66.4
14.4	1.65	2.00	2.00	149.2	66.2
14.5	1.65	2.00	2.00	148.9	65.9
14.5	1.65	2.00	2.00	148.7	65.7
14.6	1.65	2.00	2.00	148.4	65.4
14.6	1.65	2.00	2.00	148.2	65.2
14.7	1.65	2.00	2.00	147.9	64.9
14.7	1.65	2.00	2.00	147.7	64.7
14.8	1.65	2.00	2.00	147.5	64.4
14.9	1.65	2.00	2.00	147.2	64.2
14.9	1.65	2.00	2.00	147.0	63.9
15.0	1.65	2.00	2.00	146.7	63.7
15.0	1.65	2.00	2.00	146.5	63.4
15.1	1.65	2.00	2.00	146.2	63.2
15.2	1.65	2.00	2.00	146.0	62.9
15.2	1.65	2.00	2.00	145.7	62.7
15.3	1.65	2.00	2.00	145.5	62.4
15.3	1.65	2.00	2.00	145.2	62.2
15.4	1.65	2.00	2.00	145.0	61.9
15.5	1.65	2.00	2.00	144.7	61.7
15.5	1.65	2.00	2.00	144.5	61.4
15.6	1.65	2.00	2.00	144.2	61.2
15.6	1.65	2.00	2.00	144.0	60.9

Ødetail

15.7	1.65	2.00	2.00	143.7	60.7
15.8	1.65	2.00	2.00	143.5	60.4
15.8	1.65	2.00	2.00	143.2	60.2
15.9	1.65	2.00	2.00	143.0	59.9
15.9	1.65	2.00	2.00	142.8	59.7
16.0	1.65	2.00	2.00	142.5	59.4
16.0	1.65	2.00	2.00	142.3	59.2
16.1	1.65	2.00	2.00	142.0	58.9
16.2	1.65	2.00	2.00	141.8	58.7
16.2	1.65	2.00	2.00	141.5	58.4
16.3	1.65	2.00	2.00	141.3	58.2
16.3	1.65	2.00	2.00	141.0	57.9
16.4	1.65	2.00	2.00	140.8	57.7
16.5	1.65	2.00	2.00	140.5	57.4
16.5	1.65	2.00	2.00	140.3	57.2
16.6	1.65	2.00	2.00	140.0	56.9
16.6	1.65	2.00	2.00	139.8	56.7
16.7	1.65	2.00	2.00	139.5	56.4
16.8	1.65	2.00	2.00	139.3	56.2
16.8	1.65	2.00	2.00	139.0	55.9
16.9	1.65	2.00	2.00	138.8	55.7
16.9	1.65	2.00	2.00	138.5	55.4
17.0	1.65	2.00	2.00	138.3	55.2
17.1	1.65	2.00	2.00	138.1	54.9
17.1	1.65	2.00	2.00	137.8	54.7
17.2	1.65	2.00	2.00	137.6	54.4
17.2	1.65	2.00	2.00	137.3	54.2
17.3	1.65	2.00	2.00	137.1	53.9
17.3	1.65	2.00	2.00	136.8	53.7
17.4	1.65	2.00	2.00	136.6	53.4
17.5	1.65	2.00	2.00	136.3	53.2
17.5	1.65	2.00	2.00	136.1	52.9
17.6	1.65	2.00	2.00	135.8	52.7
17.6	1.65	2.00	2.00	135.6	52.4
17.7	1.65	2.00	2.00	135.3	52.2
17.8	1.65	2.00	2.00	135.1	51.9
17.8	1.65	2.00	2.00	134.8	51.7
17.9	1.65	2.00	2.00	134.6	51.4
17.9	1.65	2.00	2.00	134.3	51.2
18.0	1.65	2.00	2.00	134.1	50.9
18.1	1.65	2.00	2.00	133.9	50.6
18.1	1.65	2.00	2.00	133.6	50.4
18.2	1.65	2.00	2.00	133.4	50.1
18.2	1.65	2.00	2.00	133.1	49.9
18.3	1.65	2.00	2.00	132.9	49.6
18.4	1.65	2.00	2.00	132.6	49.4
18.4	1.65	2.00	2.00	132.4	49.1
18.5	1.65	2.00	2.00	132.1	48.9
18.5	1.65	2.00	2.00	131.9	48.6
18.6	1.65	2.00	2.00	131.6	48.4
18.6	1.65	2.00	2.00	131.4	48.1
18.7	1.65	2.00	2.00	131.1	47.9
18.8	1.65	2.00	2.00	130.9	47.6
18.8	1.65	2.00	2.00	130.6	47.4
18.9	1.65	2.00	2.00	130.4	47.1
18.9	1.65	2.00	2.00	130.1	46.9
19.0	1.65	2.00	2.00	129.9	46.6
19.1	1.65	2.00	2.00	129.6	46.4
19.1	1.65	2.00	2.00	129.4	46.1
19.2	1.65	2.00	2.00	129.2	45.9
19.2	1.65	2.00	2.00	128.9	45.6
19.3	1.65	2.00	2.00	128.7	45.4
19.4	1.65	2.00	2.00	128.4	45.1
19.4	1.65	2.00	2.00	128.2	44.9
19.5	1.65	2.00	2.00	127.9	44.6
19.5	1.65	2.00	2.00	127.7	44.4
19.6	1.65	2.00	2.00	127.4	44.1

Ødetail

19.7	1.65	2.00	2.00	127.2	43.9
19.7	1.65	2.00	2.00	126.9	43.6
19.8	1.65	2.00	2.00	126.7	43.4
19.8	1.65	2.00	2.00	126.4	43.1
19.9	1.65	2.00	2.00	126.2	42.9
19.9	1.65	2.00	2.00	125.9	42.6
20.0	1.65	2.00	2.00	125.7	42.4
20.1	1.65	2.00	2.00	125.4	42.1
20.1	1.65	2.00	2.00	125.2	41.9
20.2	1.65	2.00	2.00	124.9	41.6
20.2	1.65	2.00	2.00	124.7	41.4
20.3	1.65	2.00	2.00	124.5	41.1
20.4	1.65	2.00	2.00	124.2	40.9
20.4	1.65	2.00	2.00	124.0	40.6
20.5	1.65	2.00	2.00	123.7	40.4
20.5	1.65	2.00	2.00	123.5	40.1
20.6	1.65	2.00	2.00	123.2	39.9
20.7	1.65	2.00	2.00	123.0	39.6
20.7	1.65	2.00	2.00	122.7	39.4
20.8	1.65	2.00	2.00	122.5	39.1
20.8	1.65	2.00	2.00	122.2	38.9
20.9	1.65	2.00	2.00	122.0	38.6
21.0	1.65	2.00	2.00	121.7	38.4
21.0	1.65	2.00	2.00	121.5	38.1
21.1	1.65	2.00	2.00	121.2	37.9
21.1	1.65	2.00	2.00	121.0	37.6
21.2	1.65	2.00	2.00	120.7	37.4
21.3	1.65	2.00	2.00	120.5	37.1
21.3	1.65	2.00	2.00	120.2	36.9
21.4	1.65	2.00	2.00	120.0	36.6
21.4	1.65	2.00	2.00	119.8	36.4
21.5	1.65	2.00	2.00	119.5	36.1
21.5	1.65	2.00	2.00	119.3	35.9
21.6	1.65	2.00	2.00	119.0	35.6
21.7	1.65	2.00	2.00	118.8	35.4
21.7	1.65	2.00	2.00	118.5	35.1
21.8	1.65	2.00	2.00	118.3	34.9
21.8	1.65	2.00	2.00	118.0	34.6
21.9	1.65	2.00	2.00	117.8	34.4
22.0	1.65	2.00	2.00	117.5	34.1
22.0	1.65	2.00	2.00	117.3	33.8
22.1	1.65	2.00	2.00	117.0	33.6
22.1	1.65	2.00	2.00	116.8	33.3
22.2	1.65	2.00	2.00	116.5	33.1
22.3	1.65	2.00	2.00	116.3	32.8
22.3	1.65	2.00	2.00	116.0	32.6
22.4	1.65	2.00	2.00	115.8	32.3
22.4	1.65	2.00	2.00	115.5	32.1
22.5	1.65	2.00	2.00	115.3	31.8
22.6	1.65	2.00	2.00	115.1	31.6
22.6	1.65	2.00	2.00	114.8	31.3
22.7	1.65	2.00	2.00	114.6	31.1
22.7	1.65	2.00	2.00	114.3	30.8
22.8	1.65	2.00	2.00	114.1	30.6
22.8	1.65	2.00	2.00	113.8	30.3
22.9	1.65	2.00	2.00	113.6	30.1
23.0	1.65	2.00	2.00	113.3	29.8
23.0	1.65	2.00	2.00	113.1	29.6
23.1	1.65	2.00	2.00	112.8	29.3
23.1	1.65	2.00	2.00	112.6	29.1
23.2	1.65	2.00	2.00	112.3	28.8
23.3	1.65	2.00	2.00	112.1	28.6
23.3	1.65	2.00	2.00	111.8	28.3
23.4	1.65	2.00	2.00	111.6	28.1
23.4	1.65	2.00	2.00	111.3	27.8
23.5	1.65	2.00	2.00	111.1	27.6
23.6	1.65	2.00	2.00	110.8	27.3

Ødetail

23.6	1.65	2.00	2.00	110.6	27.1
23.7	1.65	2.00	2.00	110.4	26.8
23.7	1.65	2.00	2.00	110.1	26.6
23.8	1.65	2.00	2.00	109.9	26.3
23.9	1.65	2.00	2.00	109.6	26.1
23.9	1.65	2.00	2.00	109.4	25.8
24.0	1.65	2.00	2.00	109.1	25.6
24.0	1.65	2.00	2.00	108.9	25.3
24.1	1.65	2.00	2.00	108.6	25.1
24.1	1.65	2.00	2.00	108.4	24.8
24.2	1.65	2.00	2.00	108.1	24.6
24.3	1.65	2.00	2.00	107.9	24.3
24.3	1.65	2.00	2.00	107.6	24.1
24.4	1.65	2.00	2.00	107.4	23.8
24.4	1.65	2.00	2.00	107.1	23.6
24.5	1.65	2.00	2.00	106.9	23.3
24.6	1.65	2.00	2.00	106.6	23.1
24.6	1.65	2.00	2.00	106.4	22.8
24.7	1.65	2.00	2.00	106.2	22.6
24.7	1.65	2.00	2.00	105.9	22.3
24.8	1.65	2.00	2.00	105.7	22.1
24.9	1.65	2.00	2.00	105.4	21.8
24.9	1.65	2.00	2.00	105.2	21.6
25.0	1.65	2.00	2.00	104.9	21.3
25.0	1.65	2.00	2.00	104.7	21.1
25.1	1.65	2.00	2.00	104.4	20.8
25.2	1.65	2.00	2.00	104.2	20.6
25.2	1.65	2.00	2.00	103.9	20.3
25.3	1.65	2.00	2.00	103.7	20.1
25.3	1.65	2.00	2.00	103.4	19.8
25.4	1.65	2.00	2.00	103.2	19.6
25.4	1.65	2.00	2.00	102.9	19.3
25.5	1.65	2.00	2.00	102.7	19.1
25.6	1.65	2.00	2.00	102.4	18.8
25.6	1.65	2.00	2.00	102.2	18.6
25.7	1.65	2.00	2.00	101.9	18.3
25.7	1.65	2.00	2.00	101.7	18.1
25.8	1.65	2.00	2.00	101.5	17.8
25.9	1.65	2.00	2.00	101.2	17.6
25.9	1.65	2.00	2.00	101.0	17.3
26.0	1.65	2.00	2.00	100.7	17.1
26.0	1.65	2.00	2.00	100.5	16.8
26.1	1.65	2.00	2.00	100.2	16.5
26.2	1.65	2.00	2.00	100.0	16.3
26.2	1.65	2.00	2.00	99.7	16.0
26.3	1.65	2.00	2.00	99.5	15.8
26.3	1.65	2.00	2.00	99.2	15.5
26.4	1.65	2.00	2.00	99.0	15.3
26.5	1.65	2.00	2.00	98.7	15.0
26.5	1.65	2.00	2.00	98.5	14.8
26.6	1.65	2.00	2.00	98.2	14.5
26.6	1.65	2.00	2.00	98.0	14.3
26.7	1.65	2.00	2.00	97.7	14.0
26.7	1.65	2.00	2.00	97.5	13.8
26.8	1.65	2.00	2.00	97.2	13.5
26.9	1.65	2.00	2.00	97.0	13.3
26.9	1.65	2.00	2.00	96.8	13.0
27.0	1.65	2.00	2.00	96.5	12.8
27.0	1.65	2.00	2.00	96.3	12.5
27.1	1.65	2.00	2.00	96.0	12.3
27.2	1.65	2.00	2.00	95.8	12.0
27.2	1.65	2.00	2.00	95.5	11.8
27.3	1.65	2.00	2.00	95.3	11.5
27.3	1.65	2.00	2.00	95.0	11.3
27.4	1.65	2.00	2.00	94.8	11.0
27.5	1.65	2.00	2.00	94.5	10.8
27.5	1.65	2.00	2.00	94.3	10.5

Ødetail

27.6	1.65	2.00	2.00	94.0	10.3
27.6	1.65	2.00	2.00	93.8	10.0
27.7	1.65	2.00	2.00	93.5	9.8
27.8	1.65	2.00	2.00	93.3	9.5
27.8	1.65	2.00	2.00	93.0	9.3
27.9	1.65	2.00	2.00	92.8	9.0
27.9	1.65	2.00	2.00	92.5	8.8
28.0	1.65	2.00	2.00	92.3	8.5
28.0	1.65	2.00	2.00	92.1	8.3
28.1	1.65	2.00	2.00	91.8	8.0
28.2	1.65	2.00	2.00	91.6	7.8
28.2	1.65	2.00	2.00	91.3	7.5
28.3	1.65	2.00	2.00	91.1	7.3
28.3	1.65	2.00	2.00	90.8	7.0
28.4	1.65	2.00	2.00	90.6	6.8
28.5	1.65	2.00	2.00	90.3	6.5
28.5	1.65	2.00	2.00	90.1	6.3
28.6	1.65	2.00	2.00	89.8	6.0
28.6	1.65	2.00	2.00	89.6	5.8
28.7	1.65	2.00	2.00	89.3	5.5
28.8	1.65	2.00	2.00	89.1	5.3
28.8	1.65	2.00	2.00	88.8	5.0
28.9	1.65	2.00	2.00	88.6	4.8
28.9	1.65	2.00	2.00	88.3	4.5
29.0	1.65	2.00	2.00	88.1	4.3
29.1	1.65	2.00	2.00	87.8	4.0
29.1	1.65	2.00	2.00	87.6	3.8
29.2	1.65	2.00	2.00	87.4	3.5
29.2	1.65	2.00	2.00	87.1	3.3
29.3	1.65	2.00	2.00	86.9	3.0
29.3	1.65	2.00	2.00	86.6	2.8
29.4	1.65	2.00	2.00	86.4	2.5
29.5	1.65	2.00	2.00	86.1	2.3
29.5	1.65	2.00	2.00	85.9	2.0
29.6	1.65	2.00	2.00	85.6	1.8
29.6	1.65	2.00	2.00	85.4	1.5
29.7	1.65	2.00	2.00	85.1	1.3
29.8	1.65	2.00	2.00	84.9	1.0
29.8	1.65	2.00	2.00	84.6	0.8
29.9	1.65	2.00	2.00	84.4	0.5
29.9	1.65	2.00	2.00	84.1	0.3
30.0	1.65	2.00	2.00	83.9	0.0

Zs - Soil Depth, Depth from Ground Surface
 Zp - Pile Depth, Depth from Pile Top
 Sv - Vertical Effective Stress in Soils
 Sf_dw - Uplift Side Resistance between Soil and Pile
 Sf_up - Uplift Side Resistance between Soil and Pile
 Q_dw - Downward Axial Force in Pile Shaft (Ultimate Uplift Capacity)
 Q_up - Uplift Axial Force in Pile Shaft (Ultimate Uplift Capacity)

Vertical Load vs. Total Settlement

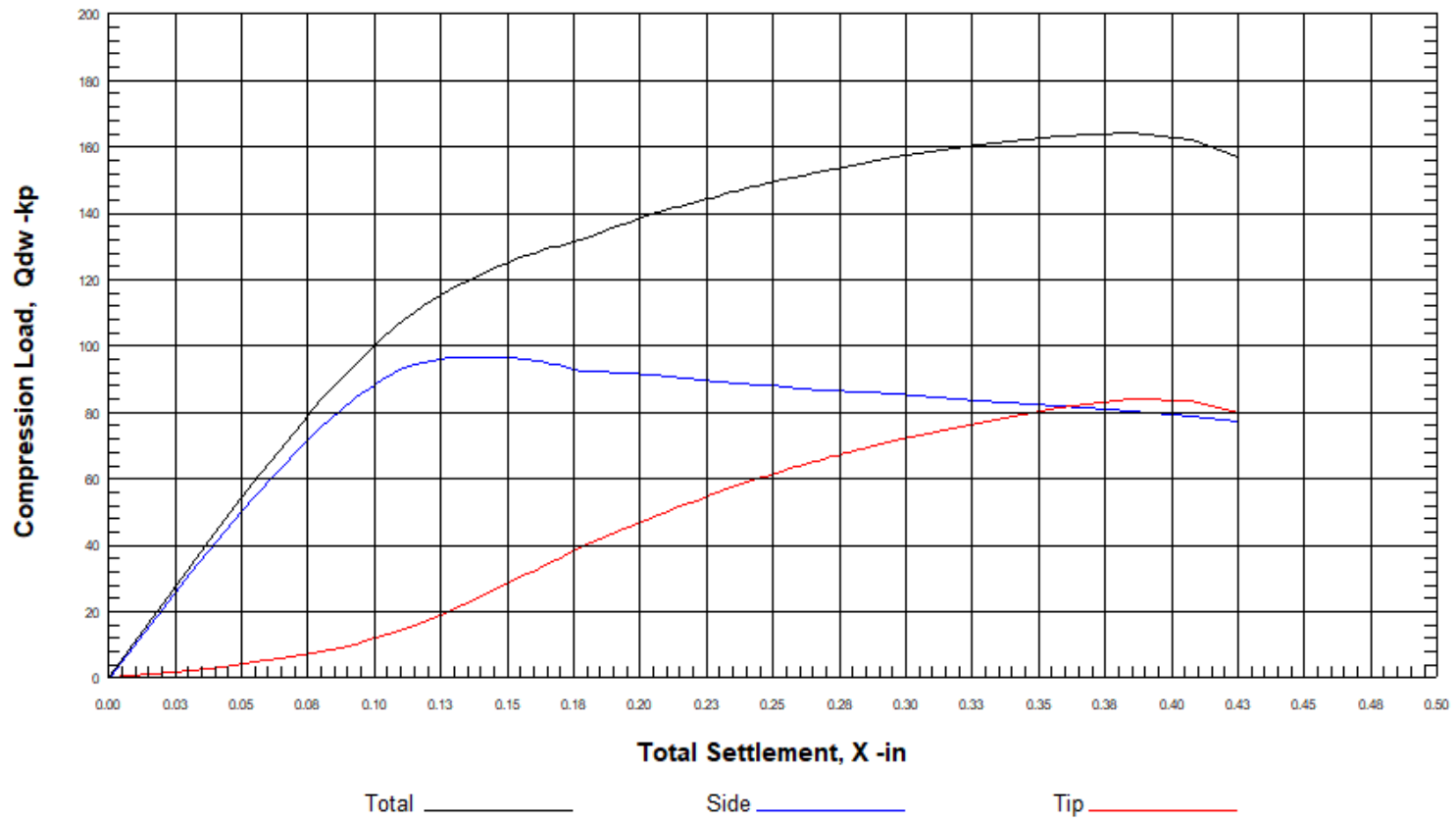

ØLoad_L

Vertical Side and Tip Resistance vs. Total Settlement:

Xtop -in	Qside -kp	Qtip -kp	Qtotal -kp
0.001	0.5	0.1	0.6
0.031	31.8	2.4	34.1
0.044	43.9	3.5	47.5
0.054	54.2	4.7	58.9
0.064	62.8	5.8	68.6
0.073	69.9	6.9	76.8
0.080	75.8	8.1	83.8
0.087	80.5	9.2	89.7
0.093	84.4	10.3	94.7
0.098	87.4	11.4	98.9
0.103	89.9	12.6	102.4
0.107	91.8	13.7	105.4
0.111	93.2	14.8	108.0
0.115	94.3	15.9	110.2
0.118	95.1	17.0	112.1
0.122	95.7	18.1	113.8
0.125	96.1	19.1	115.3
0.128	96.4	20.2	116.6
0.131	96.6	21.3	117.9
0.134	96.7	22.3	119.0
0.136	96.8	23.4	120.1
0.139	96.8	24.4	121.2
0.142	96.8	25.4	122.2
0.145	96.7	26.4	123.1
0.147	96.7	27.4	124.1
0.150	96.6	28.4	124.9
0.152	96.4	29.4	125.8
0.155	96.2	30.3	126.6
0.157	96.0	31.3	127.3
0.160	95.8	32.2	128.0
0.162	95.5	33.1	128.6
0.164	95.1	34.1	129.2
0.167	94.7	35.0	129.7
0.169	94.3	35.8	130.1
0.171	93.8	36.7	130.6
0.173	93.4	37.6	131.0
0.175	93.0	38.4	131.4
0.177	92.6	39.3	131.8
0.180	92.2	40.1	132.3
0.182	92.4	40.9	133.3
0.185	92.3	41.7	134.0
0.187	92.2	42.5	134.7
0.189	92.1	43.3	135.4
0.191	92.0	44.0	136.0
0.194	91.9	44.8	136.7
0.196	91.8	45.5	137.3
0.198	91.6	46.3	137.9
0.200	91.5	47.0	138.5
0.202	91.4	47.7	139.1
0.205	91.2	48.4	139.6
0.207	91.1	49.0	140.1
0.209	90.9	49.7	140.7
0.211	90.8	50.4	141.2
0.213	90.6	51.0	141.6
0.215	90.5	51.6	142.1
0.217	90.3	52.3	142.6
0.219	90.1	52.9	143.0
0.221	90.0	53.5	143.5

ØLoad_L

0.223	89.8	54.1	143.9
0.225	89.7	54.6	144.3
0.227	89.5	55.2	144.7
0.229	89.3	55.8	145.1
0.231	89.2	56.3	145.5
0.233	89.1	56.9	145.9
0.235	88.9	57.4	146.3
0.236	88.8	57.9	146.7
0.238	88.7	58.4	147.1
0.240	88.6	58.9	147.5
0.242	88.5	59.4	147.9
0.244	88.4	59.9	148.3
0.246	88.3	60.4	148.7
0.248	88.2	60.8	149.0
0.249	88.1	61.3	149.4
0.251	88.0	61.8	149.7
0.253	87.9	62.2	150.1
0.255	87.7	62.6	150.4
0.257	87.6	63.1	150.6
0.258	87.4	63.5	150.9
0.260	87.1	63.9	151.0
0.262	87.1	64.3	151.4
0.264	87.0	64.7	151.7
0.265	86.9	65.1	152.0
0.267	86.8	65.5	152.4
0.269	86.8	65.9	152.7
0.271	86.7	66.3	153.0
0.272	86.6	66.7	153.2
0.274	86.5	67.0	153.5
0.276	86.4	67.4	153.8
0.277	86.3	67.7	154.1
0.279	86.3	68.1	154.4
0.281	86.2	68.4	154.6
0.282	86.1	68.8	154.9
0.284	86.0	69.1	155.1
0.286	85.9	69.5	155.4
0.296	85.4	71.4	156.8
0.327	83.8	77.0	160.7
0.357	82.1	81.4	163.4
0.384	80.4	83.9	164.3
0.407	78.7	83.5	162.3
0.425	77.1	79.8	156.8

Xtop - Total Vertical Settlement
Qside - Vertical Side Resistance (Down)
Qtip - Vertical Tip Resistance (Down)
Qtotal - Vertical Total Resistance (Ultimate)

ULTIMATE CAPACITY vs FOUNDATION DEPTH

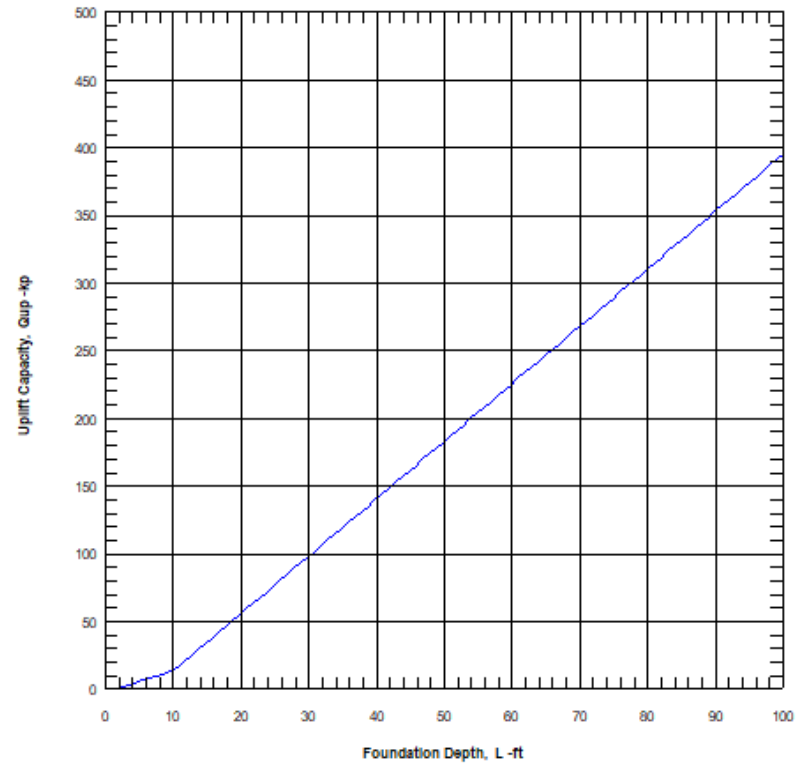
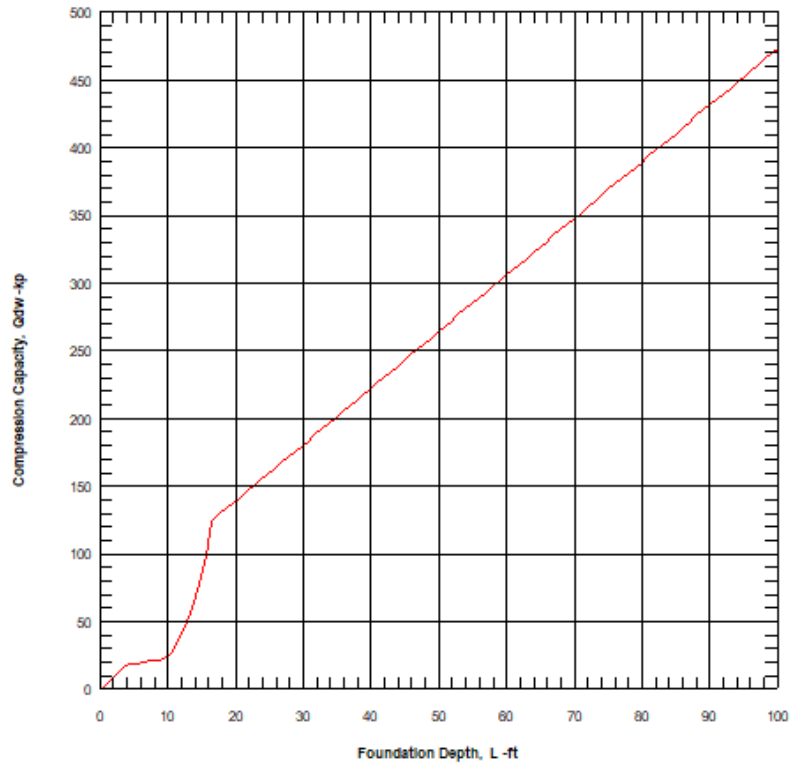

Downward and Uplift Capacity vs Pile Length

The results are for single section pile. Multiple sections may not be correct!

Length -ft	Qtip -kp	Qside -kp	Q_dw -kp	Qd_alw -kp	Weight -kp	Qsid* -kp	Q_up -kp	Qu_alw -kp
0.50	1.69	0.01	1.7	0.85	0.03	0.01	0.04	0.03
1.51	5.44	1.06	6.5	3.43	0.08	1.06	1.14	0.61
2.51	8.89	2.20	11.1	5.91	0.14	2.20	2.34	1.24
3.52	12.24	3.41	15.7	8.40	0.20	3.41	3.61	1.90
4.52	13.48	4.71	18.2	9.88	0.25	4.71	4.96	2.61
5.53	13.30	6.09	19.4	10.71	0.31	6.09	6.40	3.35
6.53	12.77	7.54	20.3	11.41	0.37	7.54	7.91	4.14
7.54	12.05	9.08	21.1	12.08	0.42	9.08	9.50	4.96
8.54	11.23	10.69	21.9	12.74	0.48	10.69	11.17	5.83
9.55	10.35	12.39	22.7	13.43	0.53	12.39	12.92	6.73
10.55	11.27	15.47	26.7	15.95	0.59	15.47	16.06	8.33
11.56	15.77	19.68	35.4	21.00	0.65	19.68	20.33	10.49
12.56	22.32	23.84	46.2	27.05	0.71	23.84	24.55	12.63
13.57	32.11	28.09	60.2	34.78	0.77	28.09	28.85	14.81
14.57	44.51	32.30	76.8	43.78	0.83	32.30	33.12	16.97
15.58	61.73	36.47	98.2	55.18	0.88	36.47	37.35	19.12
16.58	84.07	40.70	124.8	69.17	0.94	40.70	41.64	21.29
17.59	84.14	44.87	129.0	71.99	1.00	44.87	45.87	23.44
18.59	84.06	49.04	133.1	74.72	1.06	49.04	50.09	25.58
19.60	84.14	53.25	137.4	77.58	1.12	53.26	54.37	27.74
20.60	84.00	57.51	141.5	80.34	1.17	57.51	58.69	29.93
21.61	84.19	61.69	145.9	83.23	1.23	61.69	62.93	32.08
22.61	84.01	65.87	149.9	85.92	1.29	65.87	67.17	34.23
23.62	84.03	70.04	154.1	88.71	1.35	70.04	71.39	36.37
24.62	83.80	74.29	158.1	91.43	1.41	74.29	75.70	38.55
25.63	83.81	78.51	162.3	94.24	1.47	78.51	79.98	40.72
26.63	83.86	82.68	166.5	97.05	1.52	82.68	84.21	42.87
27.64	84.00	86.92	170.9	99.95	1.58	86.92	88.50	45.04
28.64	83.93	91.09	175.0	102.69	1.64	91.09	92.73	47.19
29.65	83.99	95.32	179.3	105.54	1.70	95.32	97.02	49.36
30.65	83.84	99.46	183.3	108.23	1.76	99.46	101.22	51.49
31.66	83.89	103.65	187.5	111.05	1.82	103.65	105.47	53.64
32.66	83.76	107.89	191.7	113.81	1.87	107.89	109.76	55.82
33.67	83.86	112.18	196.0	116.71	1.93	112.18	114.11	58.02
34.67	83.83	116.35	200.2	119.48	1.99	116.35	118.34	60.16
35.68	84.05	120.56	204.6	122.40	2.05	120.56	122.61	62.33
36.68	83.73	124.63	208.4	124.95	2.11	124.63	126.74	64.42
37.69	83.72	128.91	212.6	127.80	2.17	128.91	131.08	66.62
38.69	84.04	133.05	217.1	130.72	2.22	133.05	135.27	68.75
39.70	83.79	137.40	221.2	133.50	2.28	137.40	139.69	70.98
40.70	83.92	141.60	225.5	136.36	2.34	141.60	143.94	73.14
41.71	83.93	145.63	229.6	139.06	2.40	145.63	148.03	75.21
42.71	83.85	149.88	233.7	141.85	2.46	149.88	152.34	77.40
43.72	83.67	154.17	237.8	144.61	2.52	154.17	156.68	79.60
44.72	83.93	158.26	242.2	147.47	2.57	158.27	160.84	81.71
45.73	84.13	162.60	246.7	150.47	2.63	162.60	165.23	83.93
46.73	83.67	166.74	250.4	153.00	2.69	166.74	169.43	86.06
47.74	83.71	170.90	254.6	155.79	2.75	170.90	173.65	88.20
48.74	83.67	175.08	258.7	158.55	2.81	175.08	177.89	90.35
49.75	84.16	179.28	263.4	161.60	2.87	179.28	182.15	92.51
50.75	83.98	183.50	267.5	164.32	2.92	183.50	186.42	94.67
51.76	83.73	187.74	271.5	167.02	2.98	187.74	190.72	96.85
52.76	84.04	192.00	276.0	170.02	3.04	192.00	195.04	99.04
53.77	83.65	196.27	279.9	172.67	3.10	196.28	199.37	101.24
54.77	83.84	200.31	284.1	175.46	3.16	200.31	203.47	103.31
55.78	84.01	204.62	288.6	178.42	3.22	204.62	207.84	105.53
56.78	84.11	208.68	292.8	181.17	3.27	208.68	211.95	107.61
57.79	84.18	213.02	297.2	184.11	3.33	213.02	216.36	109.84
58.79	84.17	217.11	301.3	186.82	3.39	217.11	220.50	111.94
59.80	84.14	221.49	305.6	189.73	3.45	221.49	224.94	114.19

					ØLoad_L			
60.80	84.03	225.59	309.6	192.41	3.51	225.60	229.10	116.30
61.81	83.90	229.71	313.6	195.09	3.56	229.71	233.28	118.42
62.81	83.72	233.84	317.6	197.75	3.62	233.84	237.46	120.54
63.82	84.23	238.28	322.5	200.97	3.68	238.28	241.96	122.82
64.82	83.97	242.43	326.4	203.60	3.74	242.43	246.17	124.96
65.83	83.65	246.59	330.2	206.22	3.80	246.59	250.39	127.09
66.83	84.09	250.76	334.9	209.22	3.86	250.76	254.62	129.24
67.84	83.68	254.94	338.6	211.80	3.91	254.94	258.86	131.39
68.84	84.06	259.13	343.2	214.79	3.97	259.13	263.11	133.54
69.85	83.53	263.33	346.9	217.32	4.03	263.33	267.36	135.70
70.85	83.85	267.54	351.4	220.28	4.09	267.54	271.63	137.86
71.86	84.13	271.76	355.9	223.24	4.15	271.76	275.91	140.03
72.86	83.52	275.99	359.5	225.75	4.21	275.99	280.20	142.20
73.87	83.78	280.23	364.0	228.71	4.26	280.23	284.49	144.38
74.87	83.98	284.48	368.5	231.64	4.32	284.48	288.80	146.56
75.88	84.15	288.73	372.9	234.56	4.38	288.74	293.12	148.75
76.88	84.30	292.63	376.9	237.24	4.44	292.63	297.07	150.75
77.89	83.48	296.90	380.4	239.68	4.50	296.90	301.40	152.95
78.89	83.57	301.19	384.8	242.57	4.56	301.19	305.74	155.15
79.90	83.63	305.48	389.1	245.47	4.61	305.48	310.09	157.35
80.90	83.70	309.78	393.5	248.37	4.67	309.78	314.45	159.56
81.91	83.71	313.70	397.4	250.99	4.73	313.70	318.43	161.58
82.91	83.69	318.02	401.7	253.86	4.79	318.01	322.80	163.80
83.92	83.65	322.34	406.0	256.72	4.85	322.34	327.19	166.02
84.92	83.63	326.27	409.9	259.33	4.91	326.27	331.17	168.04
85.93	83.54	330.61	414.1	262.17	4.96	330.61	335.57	170.27
86.93	83.42	334.96	418.4	265.01	5.02	334.96	339.98	172.50
87.94	84.39	338.89	423.3	268.12	5.08	338.90	343.98	174.53
88.94	84.23	343.26	427.5	270.95	5.14	343.26	348.40	176.77
89.95	84.05	347.64	431.7	273.78	5.20	347.63	352.83	179.01
90.95	83.89	351.58	435.5	276.33	5.26	351.58	356.84	181.05
91.96	83.66	355.97	439.6	279.14	5.31	355.97	361.28	183.30
92.96	83.40	359.93	443.3	281.65	5.37	359.92	365.30	185.33
93.97	84.30	364.33	448.6	285.04	5.43	364.33	369.76	187.59
94.97	84.01	368.28	452.3	287.53	5.49	368.29	373.77	189.63
95.98	83.73	372.70	456.4	290.33	5.55	372.70	378.25	191.90
96.98	83.39	376.66	460.0	292.80	5.60	376.66	382.27	193.94
97.99	84.25	381.10	465.3	296.19	5.66	381.10	386.76	196.21
98.99	83.87	385.06	468.9	298.64	5.72	385.06	390.79	198.25
100.00	83.51	389.51	473.0	301.43	5.78	389.51	395.29	200.53

FACTOR OF SAFETY:

FSside FStip FSup FSweight

1.5 2.0 2.0 1.0

Note: Data can be selected, copied and pasted to Excel to create graphics
 Length - Pile length, distance from pile top to tip (not from ground surface)
 Qtip - Ultimate pile tip resistance
 Qside - Ultimate pile side resistance
 Q_dw - Ultimate pile downward resistance
 Qd_alw - Allowable pile downward resistance
 Weight - Weight of pile shaft
 Qsid* - Ultimate pile side uplift resistance
 Q_up - Ultimate pile uplift resistance
 Qu_alw - Allowable pile uplift resistance

Side Resistance vs. Relative Movement between Soil and Shaft (t-z)



Soil Depth (Zs): 3.7, 7.4, 11.1, 14.8, 18.4, 22.1, 25.8 -ft



ØLoad_L

Side Resistance vs. Relative Movement between Soil and Shaft (t-z)

Zs -ft	t -kp/f2	z -in
3.69	0.00	0.00
3.69	0.26	0.00
3.69	0.35	0.01
3.69	0.43	0.01
3.69	0.50	0.01
3.69	0.55	0.01
3.69	0.60	0.01
3.69	0.63	0.02
3.69	0.66	0.02
3.69	0.68	0.02
3.69	0.70	0.02
3.69	0.71	0.02
3.69	0.72	0.03
3.69	0.72	0.03
3.69	0.73	0.03
3.69	0.73	0.03
3.69	0.73	0.03
3.69	0.73	0.04
3.69	0.74	0.04
3.69	0.74	0.04
3.69	0.74	0.04
3.69	0.74	0.04
3.69	0.73	0.05
3.69	0.73	0.05
3.69	0.73	0.05
3.69	0.73	0.05
3.69	0.73	0.05
3.69	0.73	0.06
3.69	0.73	0.06
3.69	0.72	0.06
3.69	0.72	0.06
3.69	0.72	0.06
3.69	0.72	0.06
3.69	0.71	0.07
3.69	0.71	0.07
3.69	0.70	0.07
3.69	0.70	0.07
3.69	0.70	0.07
3.69	0.69	0.08
3.69	0.69	0.08
3.69	0.69	0.08
3.69	0.69	0.08
3.69	0.69	0.08
3.69	0.69	0.09
3.69	0.69	0.09
3.69	0.69	0.09
3.69	0.69	0.09
3.69	0.68	0.10
3.69	0.68	0.10
3.69	0.68	0.10
3.69	0.68	0.10
3.69	0.68	0.10
3.69	0.68	0.11
3.69	0.68	0.11
3.69	0.68	0.11
3.69	0.68	0.11
3.69	0.68	0.11
3.69	0.68	0.12

ØLoad_L

3.69	0.68	0.12
3.69	0.68	0.12
3.69	0.68	0.12
3.69	0.68	0.12
3.69	0.68	0.13
3.69	0.67	0.13
3.69	0.67	0.13
3.69	0.67	0.13
3.69	0.67	0.13
3.69	0.67	0.14
3.69	0.67	0.14
3.69	0.67	0.14
3.69	0.67	0.14
3.69	0.67	0.14
3.69	0.67	0.15
3.69	0.67	0.15
3.69	0.67	0.15
3.69	0.67	0.15
3.69	0.67	0.15
3.69	0.67	0.16
3.69	0.67	0.16
3.69	0.66	0.16
3.69	0.66	0.16
3.69	0.66	0.16
3.69	0.66	0.17
3.69	0.66	0.17
3.69	0.66	0.17
3.69	0.66	0.17
3.69	0.66	0.17
3.69	0.66	0.18
3.69	0.66	0.18
3.69	0.66	0.18
3.69	0.66	0.18
3.69	0.66	0.18
3.69	0.66	0.19
3.69	0.66	0.19
3.69	0.65	0.20
3.69	0.64	0.24
3.69	0.63	0.28
3.69	0.61	0.32
3.69	0.60	0.36
3.69	0.59	0.40

Zs	t	z
-ft	-kp/f2	-in
7.38	0.01	0.00
7.38	0.31	0.00
7.38	0.43	0.01
7.38	0.53	0.01
7.38	0.61	0.01
7.38	0.67	0.01
7.38	0.73	0.01
7.38	0.77	0.02
7.38	0.80	0.02
7.38	0.83	0.02
7.38	0.85	0.02
7.38	0.87	0.02
7.38	0.88	0.03
7.38	0.88	0.03
7.38	0.89	0.03
7.38	0.89	0.03
7.38	0.90	0.03
7.38	0.90	0.04
7.38	0.90	0.04
7.38	0.90	0.04
7.38	0.90	0.04

ØLoad_L

7.38	0.90	0.04
7.38	0.90	0.05
7.38	0.90	0.05
7.38	0.90	0.05
7.38	0.89	0.05
7.38	0.89	0.05
7.38	0.89	0.06
7.38	0.89	0.06
7.38	0.88	0.06
7.38	0.88	0.06
7.38	0.88	0.06
7.38	0.87	0.07
7.38	0.87	0.07
7.38	0.86	0.07
7.38	0.85	0.07
7.38	0.85	0.07
7.38	0.84	0.08
7.38	0.84	0.08
7.38	0.84	0.08
7.38	0.84	0.08
7.38	0.84	0.08
7.38	0.84	0.08
7.38	0.84	0.09
7.38	0.84	0.09
7.38	0.84	0.09
7.38	0.84	0.09
7.38	0.84	0.09
7.38	0.84	0.10
7.38	0.84	0.10
7.38	0.84	0.10
7.38	0.83	0.10
7.38	0.83	0.10
7.38	0.83	0.11
7.38	0.83	0.11
7.38	0.83	0.11
7.38	0.83	0.11
7.38	0.83	0.11
7.38	0.83	0.12
7.38	0.83	0.12
7.38	0.83	0.12
7.38	0.83	0.12
7.38	0.83	0.12
7.38	0.83	0.12
7.38	0.83	0.13
7.38	0.82	0.13
7.38	0.82	0.13
7.38	0.82	0.13
7.38	0.82	0.14
7.38	0.82	0.14
7.38	0.82	0.14
7.38	0.82	0.14
7.38	0.82	0.14
7.38	0.82	0.15
7.38	0.82	0.15
7.38	0.82	0.15
7.38	0.82	0.15
7.38	0.81	0.15
7.38	0.81	0.16
7.38	0.81	0.16
7.38	0.81	0.16
7.38	0.81	0.16
7.38	0.81	0.16
7.38	0.81	0.17
7.38	0.81	0.17
7.38	0.81	0.17
7.38	0.81	0.17
7.38	0.81	0.18

ØLoad_L

7.38	0.81	0.18
7.38	0.80	0.18
7.38	0.80	0.18
7.38	0.80	0.18
7.38	0.80	0.19
7.38	0.80	0.19
7.38	0.80	0.20
7.38	0.78	0.24
7.38	0.77	0.28
7.38	0.75	0.32
7.38	0.74	0.36
7.38	0.72	0.40

Zs	t	z
-ft	-kp/f2	-in
11.06	0.00	0.00
11.06	0.54	0.00
11.06	0.76	0.01
11.06	0.95	0.01
11.06	1.12	0.01
11.06	1.26	0.01
11.06	1.39	0.01
11.06	1.50	0.02
11.06	1.59	0.02
11.06	1.66	0.02
11.06	1.73	0.02
11.06	1.78	0.02
11.06	1.83	0.03
11.06	1.86	0.03
11.06	1.89	0.03
11.06	1.92	0.03
11.06	1.93	0.03
11.06	1.95	0.04
11.06	1.96	0.04
11.06	1.97	0.04
11.06	1.97	0.04
11.06	1.98	0.04
11.06	1.98	0.05
11.06	1.98	0.05
11.06	1.98	0.05
11.06	1.98	0.05
11.06	1.98	0.05
11.06	1.98	0.06
11.06	1.98	0.06
11.06	1.98	0.06
11.06	1.98	0.06
11.06	1.98	0.06
11.06	1.98	0.07
11.06	1.98	0.07
11.06	1.98	0.07
11.06	1.98	0.07
11.06	1.98	0.07
11.06	1.98	0.08
11.06	1.98	0.08
11.06	1.97	0.08
11.06	1.97	0.08
11.06	1.97	0.08
11.06	1.97	0.09
11.06	1.96	0.09
11.06	1.96	0.09
11.06	1.96	0.09
11.06	1.95	0.09
11.06	1.95	0.10
11.06	1.94	0.10
11.06	1.93	0.10
11.06	1.93	0.10

ØLoad_L

11.06	1.92	0.10
11.06	1.91	0.11
11.06	1.90	0.11
11.06	1.90	0.11
11.06	1.89	0.11
11.06	1.88	0.11
11.06	1.87	0.12
11.06	1.86	0.12
11.06	1.86	0.12
11.06	1.85	0.12
11.06	1.84	0.12
11.06	1.84	0.13
11.06	1.83	0.13
11.06	1.82	0.13
11.06	1.82	0.13
11.06	1.82	0.13
11.06	1.81	0.14
11.06	1.81	0.14
11.06	1.80	0.14
11.06	1.80	0.14
11.06	1.80	0.14
11.06	1.80	0.15
11.06	1.79	0.15
11.06	1.79	0.15
11.06	1.78	0.15
11.06	1.77	0.15
11.06	1.76	0.16
11.06	1.75	0.16
11.06	1.75	0.16
11.06	1.75	0.16
11.06	1.75	0.16
11.06	1.75	0.17
11.06	1.74	0.17
11.06	1.74	0.17
11.06	1.74	0.17
11.06	1.74	0.17
11.06	1.74	0.18
11.06	1.74	0.18
11.06	1.73	0.18
11.06	1.73	0.18
11.06	1.73	0.18
11.06	1.73	0.19
11.06	1.73	0.19
11.06	1.72	0.20
11.06	1.68	0.24
11.06	1.64	0.28
11.06	1.61	0.32
11.06	1.57	0.36
11.06	1.54	0.40

Zs	t	z
-ft	-kp/f2	-in

14.75	0.00	0.00
14.75	0.54	0.00
14.75	0.76	0.01
14.75	0.95	0.01
14.75	1.12	0.01
14.75	1.26	0.01
14.75	1.39	0.01
14.75	1.50	0.02
14.75	1.59	0.02
14.75	1.66	0.02
14.75	1.73	0.02
14.75	1.78	0.02
14.75	1.83	0.03
14.75	1.86	0.03

ØLoad_L

14.75	1.89	0.03
14.75	1.92	0.03
14.75	1.93	0.03
14.75	1.95	0.04
14.75	1.96	0.04
14.75	1.97	0.04
14.75	1.97	0.04
14.75	1.98	0.04
14.75	1.98	0.05
14.75	1.98	0.05
14.75	1.98	0.05
14.75	1.98	0.05
14.75	1.98	0.05
14.75	1.98	0.06
14.75	1.98	0.06
14.75	1.98	0.06
14.75	1.98	0.06
14.75	1.98	0.06
14.75	1.98	0.07
14.75	1.98	0.07
14.75	1.98	0.07
14.75	1.98	0.07
14.75	1.98	0.07
14.75	1.98	0.08
14.75	1.98	0.08
14.75	1.97	0.08
14.75	1.97	0.08
14.75	1.97	0.08
14.75	1.97	0.09
14.75	1.96	0.09
14.75	1.96	0.09
14.75	1.96	0.09
14.75	1.95	0.09
14.75	1.95	0.10
14.75	1.94	0.10
14.75	1.93	0.10
14.75	1.93	0.10
14.75	1.92	0.10
14.75	1.91	0.11
14.75	1.90	0.11
14.75	1.90	0.11
14.75	1.89	0.11
14.75	1.88	0.11
14.75	1.87	0.12
14.75	1.86	0.12
14.75	1.86	0.12
14.75	1.85	0.12
14.75	1.84	0.12
14.75	1.84	0.13
14.75	1.83	0.13
14.75	1.82	0.13
14.75	1.82	0.13
14.75	1.82	0.13
14.75	1.81	0.14
14.75	1.81	0.14
14.75	1.80	0.14
14.75	1.80	0.14
14.75	1.80	0.14
14.75	1.80	0.15
14.75	1.79	0.15
14.75	1.79	0.15
14.75	1.78	0.15
14.75	1.77	0.15
14.75	1.76	0.16
14.75	1.75	0.16
14.75	1.75	0.16
14.75	1.75	0.16

ØLoad_L

14.75	1.75	0.16
14.75	1.75	0.17
14.75	1.74	0.17
14.75	1.74	0.17
14.75	1.74	0.17
14.75	1.74	0.17
14.75	1.74	0.18
14.75	1.74	0.18
14.75	1.73	0.18
14.75	1.73	0.18
14.75	1.73	0.18
14.75	1.73	0.19
14.75	1.73	0.19
14.75	1.72	0.20
14.75	1.68	0.24
14.75	1.64	0.28
14.75	1.61	0.32
14.75	1.57	0.36
14.75	1.54	0.40

Zs	t	z
-ft	-kp/f2	-in
18.44	0.01	0.00
18.44	0.68	0.00
18.44	0.94	0.01
18.44	1.15	0.01
18.44	1.32	0.01
18.44	1.47	0.01
18.44	1.58	0.01
18.44	1.68	0.02
18.44	1.75	0.02
18.44	1.81	0.02
18.44	1.85	0.02
18.44	1.88	0.02
18.44	1.91	0.03
18.44	1.93	0.03
18.44	1.94	0.03
18.44	1.95	0.03
18.44	1.95	0.03
18.44	1.95	0.04
18.44	1.95	0.04
18.44	1.96	0.04
18.44	1.95	0.04
18.44	1.95	0.04
18.44	1.95	0.05
18.44	1.95	0.05
18.44	1.95	0.05
18.44	1.95	0.05
18.44	1.95	0.05
18.44	1.94	0.05
18.44	1.94	0.06
18.44	1.93	0.06
18.44	1.92	0.06
18.44	1.92	0.06
18.44	1.91	0.06
18.44	1.90	0.07
18.44	1.88	0.07
18.44	1.87	0.07
18.44	1.86	0.07
18.44	1.85	0.07
18.44	1.84	0.08
18.44	1.83	0.08
18.44	1.83	0.08
18.44	1.83	0.08
18.44	1.83	0.08
18.44	1.83	0.09
18.44	1.83	0.09

ØLoad_L

18.44	1.83	0.09
18.44	1.82	0.09
18.44	1.82	0.09
18.44	1.82	0.10
18.44	1.82	0.10
18.44	1.82	0.10
18.44	1.82	0.10
18.44	1.81	0.10
18.44	1.81	0.11
18.44	1.81	0.11
18.44	1.81	0.11
18.44	1.81	0.11
18.44	1.81	0.11
18.44	1.80	0.12
18.44	1.80	0.12
18.44	1.80	0.12
18.44	1.80	0.12
18.44	1.80	0.12
18.44	1.80	0.13
18.44	1.79	0.13
18.44	1.79	0.13
18.44	1.79	0.13
18.44	1.79	0.13
18.44	1.79	0.14
18.44	1.79	0.14
18.44	1.78	0.14
18.44	1.78	0.14
18.44	1.78	0.14
18.44	1.78	0.15
18.44	1.78	0.15
18.44	1.78	0.15
18.44	1.77	0.15
18.44	1.77	0.15
18.44	1.77	0.16
18.44	1.77	0.16
18.44	1.77	0.16
18.44	1.77	0.16
18.44	1.76	0.16
18.44	1.76	0.17
18.44	1.76	0.17
18.44	1.76	0.17
18.44	1.76	0.17
18.44	1.76	0.17
18.44	1.75	0.18
18.44	1.75	0.18
18.44	1.75	0.18
18.44	1.75	0.18
18.44	1.75	0.18
18.44	1.75	0.19
18.44	1.74	0.19
18.44	1.73	0.20
18.44	1.70	0.24
18.44	1.67	0.28
18.44	1.63	0.32
18.44	1.60	0.36
18.44	1.57	0.40

Zs	t	z
-ft	-kp/f2	-in
22.13	0.01	0.00
22.13	0.68	0.00
22.13	0.94	0.01
22.13	1.15	0.01
22.13	1.32	0.01
22.13	1.47	0.01
22.13	1.58	0.01

ØLoad_L

22.13	1.68	0.02
22.13	1.75	0.02
22.13	1.81	0.02
22.13	1.85	0.02
22.13	1.88	0.02
22.13	1.91	0.03
22.13	1.93	0.03
22.13	1.94	0.03
22.13	1.95	0.03
22.13	1.95	0.03
22.13	1.95	0.04
22.13	1.95	0.04
22.13	1.96	0.04
22.13	1.95	0.04
22.13	1.95	0.04
22.13	1.95	0.05
22.13	1.95	0.05
22.13	1.95	0.05
22.13	1.95	0.05
22.13	1.94	0.05
22.13	1.94	0.06
22.13	1.93	0.06
22.13	1.92	0.06
22.13	1.92	0.06
22.13	1.91	0.06
22.13	1.90	0.07
22.13	1.88	0.07
22.13	1.87	0.07
22.13	1.86	0.07
22.13	1.85	0.07
22.13	1.84	0.08
22.13	1.83	0.08
22.13	1.83	0.08
22.13	1.83	0.08
22.13	1.83	0.08
22.13	1.83	0.09
22.13	1.83	0.09
22.13	1.83	0.09
22.13	1.82	0.09
22.13	1.82	0.09
22.13	1.82	0.10
22.13	1.82	0.10
22.13	1.82	0.10
22.13	1.81	0.10
22.13	1.81	0.11
22.13	1.81	0.11
22.13	1.81	0.11
22.13	1.81	0.11
22.13	1.81	0.11
22.13	1.80	0.12
22.13	1.80	0.12
22.13	1.80	0.12
22.13	1.80	0.12
22.13	1.80	0.12
22.13	1.80	0.13
22.13	1.79	0.13
22.13	1.79	0.13
22.13	1.79	0.13
22.13	1.79	0.13
22.13	1.79	0.14
22.13	1.79	0.14
22.13	1.78	0.14
22.13	1.78	0.14
22.13	1.78	0.15
22.13	1.78	0.15

ØLoad_L

22.13	1.78	0.15
22.13	1.77	0.15
22.13	1.77	0.15
22.13	1.77	0.16
22.13	1.77	0.16
22.13	1.77	0.16
22.13	1.77	0.16
22.13	1.76	0.16
22.13	1.76	0.17
22.13	1.76	0.17
22.13	1.76	0.17
22.13	1.76	0.17
22.13	1.76	0.17
22.13	1.75	0.18
22.13	1.75	0.18
22.13	1.75	0.18
22.13	1.75	0.18
22.13	1.75	0.19
22.13	1.74	0.19
22.13	1.73	0.20
22.13	1.70	0.24
22.13	1.67	0.28
22.13	1.63	0.32
22.13	1.60	0.36
22.13	1.57	0.40

Zs	t	z
-ft	-kp/f2	-in
25.81	0.01	0.00
25.81	0.68	0.00
25.81	0.94	0.01
25.81	1.15	0.01
25.81	1.32	0.01
25.81	1.47	0.01
25.81	1.58	0.01
25.81	1.68	0.02
25.81	1.75	0.02
25.81	1.81	0.02
25.81	1.85	0.02
25.81	1.88	0.02
25.81	1.91	0.03
25.81	1.93	0.03
25.81	1.94	0.03
25.81	1.95	0.03
25.81	1.95	0.03
25.81	1.95	0.04
25.81	1.95	0.04
25.81	1.96	0.04
25.81	1.95	0.04
25.81	1.95	0.04
25.81	1.95	0.05
25.81	1.95	0.05
25.81	1.95	0.05
25.81	1.95	0.05
25.81	1.94	0.05
25.81	1.94	0.06
25.81	1.93	0.06
25.81	1.92	0.06
25.81	1.92	0.06
25.81	1.91	0.06
25.81	1.90	0.07
25.81	1.88	0.07
25.81	1.87	0.07
25.81	1.86	0.07
25.81	1.85	0.07

ØLoad_L

25.81	1.84	0.08
25.81	1.83	0.08
25.81	1.83	0.08
25.81	1.83	0.08
25.81	1.83	0.08
25.81	1.83	0.09
25.81	1.83	0.09
25.81	1.82	0.09
25.81	1.82	0.09
25.81	1.82	0.10
25.81	1.82	0.10
25.81	1.82	0.10
25.81	1.82	0.10
25.81	1.81	0.10
25.81	1.81	0.11
25.81	1.81	0.11
25.81	1.81	0.11
25.81	1.81	0.11
25.81	1.80	0.12
25.81	1.80	0.12
25.81	1.80	0.12
25.81	1.80	0.12
25.81	1.80	0.12
25.81	1.80	0.13
25.81	1.79	0.13
25.81	1.79	0.13
25.81	1.79	0.13
25.81	1.79	0.13
25.81	1.79	0.14
25.81	1.79	0.14
25.81	1.78	0.14
25.81	1.78	0.14
25.81	1.78	0.14
25.81	1.78	0.15
25.81	1.78	0.15
25.81	1.78	0.15
25.81	1.77	0.15
25.81	1.77	0.15
25.81	1.77	0.16
25.81	1.77	0.16
25.81	1.77	0.16
25.81	1.76	0.16
25.81	1.76	0.17
25.81	1.76	0.17
25.81	1.76	0.17
25.81	1.76	0.17
25.81	1.75	0.17
25.81	1.75	0.18
25.81	1.75	0.18
25.81	1.75	0.18
25.81	1.75	0.18
25.81	1.75	0.19
25.81	1.74	0.19
25.81	1.73	0.20
25.81	1.70	0.24
25.81	1.67	0.28
25.81	1.63	0.32
25.81	1.60	0.36
25.81	1.57	0.40

Zs - Depth from Soil Top
t - Side Resistance
z - Relative Movement between Soil and Shaft

0Load_L

Tip Resistance vs. Tip Movement (q-w)

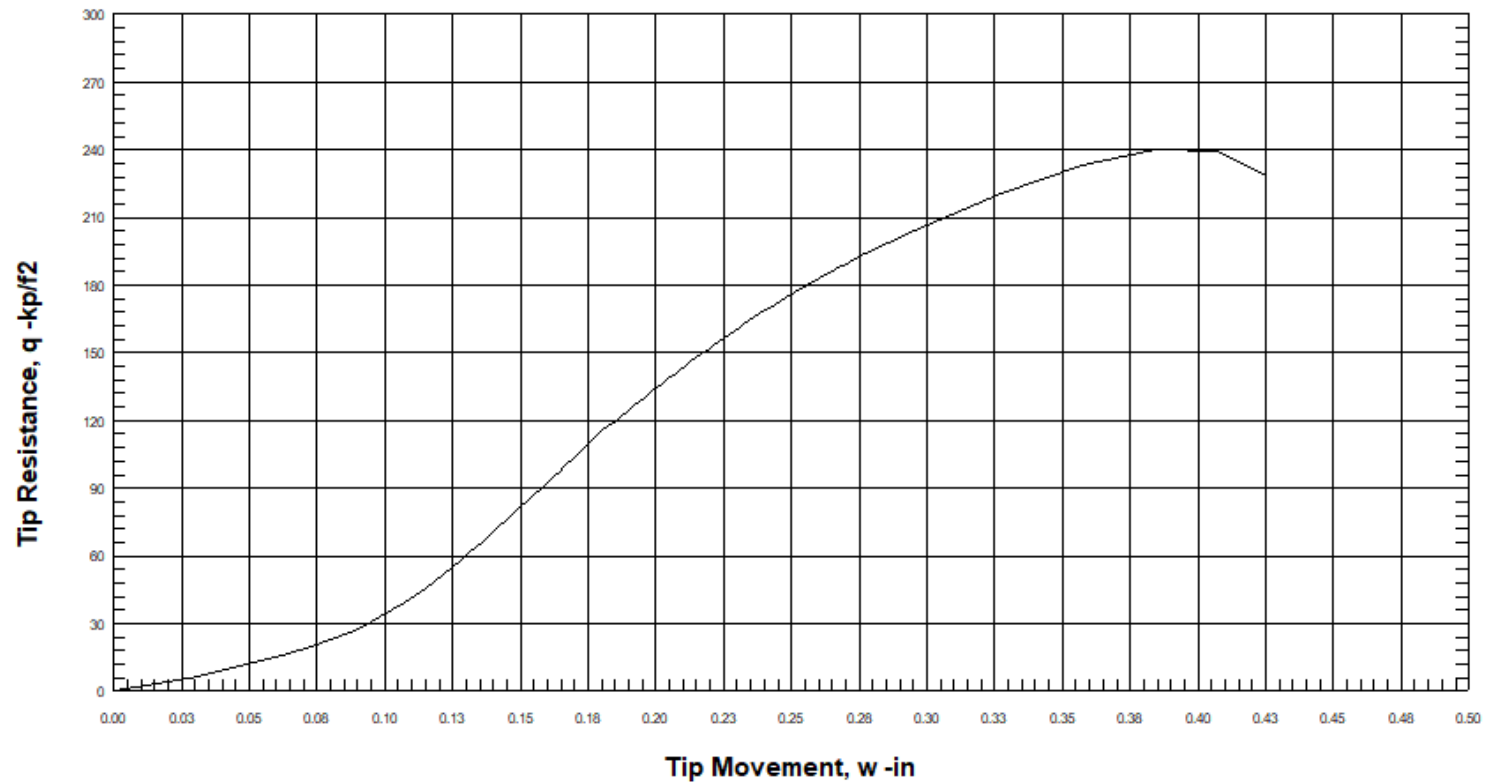

Tip Resistance vs. Tip Movement (q-w)

Depth of Pile Tip from Ground Surface = 29.50-ft

q -kp/f2	w -in
0.32	0.00
6.82	0.03
10.08	0.04
13.34	0.05
16.60	0.06
19.85	0.07
23.09	0.08
26.33	0.09
29.56	0.09
32.78	0.10
35.98	0.10
39.16	0.11
42.33	0.11
45.47	0.11
48.60	0.12
51.70	0.12
54.79	0.12
57.84	0.13
60.87	0.13
63.87	0.13
66.85	0.14
69.79	0.14
72.71	0.14
75.60	0.14
78.45	0.15
81.27	0.15
84.06	0.15
86.81	0.15
89.53	0.16
92.22	0.16
94.87	0.16
97.49	0.16
100.07	0.17
102.62	0.17
105.13	0.17
107.60	0.17
110.04	0.18
112.44	0.18
114.81	0.18
117.14	0.18
119.43	0.18
121.69	0.19
123.91	0.19
126.10	0.19
128.25	0.19
130.36	0.20
132.44	0.20
134.49	0.20
136.50	0.20
138.48	0.20
140.42	0.21
142.33	0.21
144.20	0.21
146.05	0.21
147.86	0.21
149.64	0.22
151.38	0.22

ØLoad_L

153.10	0.22
154.79	0.22
156.45	0.22
158.07	0.23
159.67	0.23
161.24	0.23
162.78	0.23
164.30	0.23
165.79	0.24
167.25	0.24
168.69	0.24
170.10	0.24
171.49	0.24
172.85	0.25
174.19	0.25
175.51	0.25
176.80	0.25
178.08	0.25
179.33	0.25
180.56	0.26
181.77	0.26
182.97	0.26
184.14	0.26
185.30	0.26
186.43	0.27
187.55	0.27
188.66	0.27
189.74	0.27
190.82	0.27
191.87	0.27
192.91	0.28
193.94	0.28
194.95	0.28
195.95	0.28
196.94	0.28
197.91	0.28
198.87	0.29
204.40	0.30
220.41	0.33
232.92	0.36
240.17	0.38
239.17	0.41
228.39	0.43

q - Tip Resistance
w - Tip Movement

LATERAL ANALYSIS

Figure 2

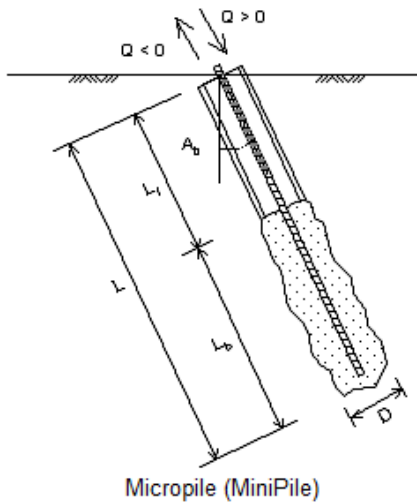

Loads:

Load Factor for Vertical Loads= 1.0
 Load Factor for Lateral Loads= 1.0
 Loads Supported by Pile Cap= 0 %
 Shear Condition: Static

(with Load Factor)

Vertical Load, Q= 100.0 -kp
 Shear Load, P= 14.0 -kp
 Slope Restrain St= 0.00000 -in/-in

Profile:

Pile Length, L= 30.0 -ft
 Top Height, H= .5 -ft
 Slope Angle, As= 0.0
 Batter Angle, Ab= 0
 Fixed Head Condition

Soil Data:

Depth -ft	Gamma -lb/f3	Phi	C -kp/f2	K -lb/i3	e50 or Dr %	Nspt
0	125	37.0	.75	122.7	57.53	23
10	120	30	.1	331.6	.85	10
16	130	40	.1	278	85.61	50

Pile Data:

Depth -ft	Width -in	Area -in2	Per. -in	I -in4	E -kp/i2	Weight -kp/f
0.0	6.625	11.1	20.8	46.1	29000	0.056
10.0	8	72.3	25.1	205.5	3000	0.058
30.0						

Single Pile Lateral Analysis:

Top Deflection, yt= 0.39600-in
 Max. Moment, M= -41.50-kp-f
 Top Deflection Slope, St= 0.00000
 OK! Top Deflection, 0.3960-in is less than the Allowable Deflection= 1.00-in

Note: If the program cannot find a result or the result exceeds the upper limit. The result will be displayed as 99999.
 The Max. Moment calculated by program is an internal force from the applied load conditions. Structural engineer has to check whether the pile has enough capacity to resist the moment with adequate factor of safety. If not, the pile may fail under the load conditions.



**CivilTech
Software**

**Lot 44
Foundations P9 & P10**



Micropile Design Calculator

V1.0

Design References: ACI 318-14; 2015 IBC; AISC Steel Construction Manual 14th ED.

Project: Lot 44 Powder Mountain P1-P8 Foundations
 Description: 150 kip ult micropile with 5"x5"x1.25" plate
 Date: 2/21/19
 Designed By: MJH

Checked By: POD

- Objectives: 1. Determine required bearing plate area, A_B
 2. Determine required bearing plate thickness, t_{req}

Loads

Ultimate Axial Design Comp. Load, P_c (kips)	150.0
Ultimate Axial Design Tension Load, P_t (kips)	1.0
Allowable Axial Design Comp. Load, P_c/SF (kips)	100.0
Allowable Axial Design Tension Load, P_t/SF (kips)	0.7

Safety Factor

SF= 1.5

Material Properties & Geometry

Grout

f'_c (ksi)	4
Bit Diameter, D (in)	8
Assumed Grout Diameter, D' (in)	8

Micropile Tendon

Bar Size	#11
f_y (ksi)	75.00
A_s (in ²)	1.41
OD (in)	1.38

Bearing Plate

f_{y-bp} (ksi)	36
Nut Diameter, D_n (in)	2.25

(reduced by corrosion)

Allowable Structural Strength

Allowable Comp. Steel, $P_{c(s)} = 0.4 \cdot f_y \cdot A'_s$ (kips)	42.3
Allowable Comp. Grout, $P_{c(g)} = 0.33 \cdot f'_c \cdot A_c$ (kips)	64.5
Allowable Comp. Strength, $P_c = P_{c(s)} + P_{c(g)}$ (kips)	106.8
Allowable Tension Steel, $P_{t(s)} = 0.6 \cdot f_y \cdot A'_s$ (kips)	63.5

Check Allowable > Load
 » COMPRESSION IS OK
 » TENSION IS OK

Corrosion Rate/Sacrificial Steel

Maximum Steel Loss Rate* (mil/yr)	0.472
Structure Design Life (yrs)	75
Sacrificial Steel (in)	0.035

Equivalent to 12 μ m/yr

1. Req'd Plate Bearing Area ACI 318-08 10.14.1

Bearing Plate Area for Compression

Req'd Bearing Area, A_{bc} (in ²)	21.00
$A_{bc} = ((P_c - P_{c(g)}) \cdot \Omega) / (0.85 \cdot f'_c) / (A_2/A_1)^{1/2}$ $(A_2/A_1)^{1/2} = 2$	
Use: A_{Bc} (in ²)	25

Bearing Plate Area for Tension

Req'd Bearing Area, A_{bt} (in ²)	1.73
$A_{bt} = ((P_t) \cdot \Omega) / (0.85 \cdot f_y) / (A_2/A_1)^{1/2} + \pi \cdot OD^2 / 4$ $(A_2/A_1)^{1/2} = 2$	
Use: A_{Bt} (in ²)	16



Micropile Design Calculator

V1.0

Design References: ACI 318-14; 2015 IBC; AISC Steel Construction Manual 14th ED.

Project: Lot 44 Powder Mountain P1-P8 Foundations
 Description: 150 kip ult micropile with 5"x5"x1.25" plate
 Date: 2/21/19
 Designed By: MJH

Checked By: POD

2. Req'd Bearing Plate Thickness

Plate Thickness for Compression

$M_{max} = wl^2/2$ (k-in)	5.40
$w = \Omega_b \cdot (P_c - P_{c(g)})/A_B$ (k/in)	5.71
$I = (A_{Bc}^{1/2} - D_n)/2$ (in)	1.38
$S_{xc-req} = M_{max}/(F_{y-bp} \cdot .67)$ (in ³)	0.22
$t_{c,req} = (6S_{xc-req})^{1/2}$ (in)	1.16
Plate Required:	5'x5'x1.25"

Plate Thickness for Tension

$M_{max} = wl^2/2$ (k-in)	0.04
$w = \Omega_b \cdot P/A_B$ (k/in)	0.10
$I = (A_{Bt}^{1/2} - D_n)/2$ (in)	0.88
$S_{xt-req} = M_{max}/(F_{y-bp} \cdot .67)$ (in ³)	0.00
$t_{t,req} = (6S_{xt-req})^{1/2}$ (in)	0.10
Plate Required:	4"x4"x0.5"



Micropile Design Calculator

V1.0

Design References: ACI 318-14; 2015 IBC; AISC Steel Construction Manual 14th ED.

Project: Lot 44 Powder Mountain P9 & P10 Foundations
 Description: 100 kip ult micropile with 4"x4"x1" plate
 Date: 2/21/19
 Designed By: MJH

Checked By: POD

- Objectives: 1. Determine required bearing plate area, A_b
 2. Determine required bearing plate thickness, t_{req}

Loads

Ultimate Axial Design Comp. Load, P_c (kips)	100.0
Ultimate Axial Design Tension Load, P_t (kips)	1.0
Allowable Axial Design Comp. Load, P_c/SF (kips)	66.7
Allowable Axial Design Tension Load, P_t/SF (kips)	0.7

Safety Factor

SF= 1.5

Material Properties & Geometry

Grout		Micropile Tendon		Bearing Plate	
f'_c (ksi)	4	Bar Size	#8	f_{y-bp} (ksi)	36
Bit Diameter, D (in)	8	f_y (ksi)	75.00	Nut Diameter, D_n (in)	1.63
Assumed Grout Diameter, D' (in)	8	A_s (in ²)	0.68 (reduced by corrosion)		
		OD (in)	1.00		

Allowable Structural Strength

Allowable Comp. Steel, $P_{c(s)} = 0.4 \cdot f_y \cdot A'_s$ (kips)	20.5	Check Allowable > Load » COMPRESSION IS OK » TENSION IS OK
Allowable Comp. Grout, $P_{c(g)} = 0.33 \cdot f'_c \cdot A_c$ (kips)	65.4	
Allowable Comp. Strength, $P_c = P_{c(s)} + P_{c(g)}$ (kips)	85.9	
Allowable Tension Steel, $P_{t(s)} = 0.6 \cdot f_y \cdot A'_s$ (kips)	30.7	

Corrosion Rate/Sacrificial Steel

Maximum Steel Loss Rate* (mil/yr)	0.472
Structure Design Life (yrs)	75
Sacrificial Steel (in)	0.035

Equivalent to 12 μ m/yr

1. Req'd Plate Bearing Area ACI 318-08 10.14.1

Bearing Plate Area for Compression

Req'd Bearing Area, A_{bc} (in ²)	8.49
$A_{bc} = ((P_c - P_{c(g)}) \cdot \Omega) / (0.85 \cdot f'_c) / (A_2/A_1)^{1/2}$ $(A_2/A_1)^{1/2} = 2$	
Use: A_{Bc} (in ²)	16

Bearing Plate Area for Tension

Req'd Bearing Area, A_{bt} (in ²)	1.03
$A_{bt} = ((P_t) \cdot \Omega) / (0.85 \cdot f_y) / (A_2/A_1)^{1/2} + \pi \cdot OD^2 / 4$ $(A_2/A_1)^{1/2} = 2$	
Use: A_{Bt} (in ²)	16



Micropile Design Calculator

V1.0

Design References: ACI 318-14; 2015 IBC; AISC Steel Construction Manual 14th ED.

Project: Lot 44 Powder Mountain P9 & P10 Foundations

Description: 100 kip ult micropile with 4"x4"x1" plate

Date: 2/21/19

Designed By: MJH

Checked By: POD

2. Req'd Bearing Plate Thickness

Plate Thickness for Compression

$M_{max} = wl^2/2$ (k-in)	2.54
$w = \Omega_b \cdot (P_c - P_{c(g)})/A_B$ (k/in)	3.61
$I = (A_{Bc}^{1/2} - D_n)/2$ (in)	1.19
$S_{xc-req} = M_{max}/(F_{y-bp} \cdot .67)$ (in ³)	0.11
$t_{c,req} = (6S_{xc-req})^{1/2}$ (in)	0.80
Plate Required:	4"x4"x1"

Plate Thickness for Tension

$M_{max} = wl^2/2$ (k-in)	0.07
$w = \Omega_b \cdot P/A_B$ (k/in)	0.10
$I = (A_{Bt}^{1/2} - D_n)/2$ (in)	1.19
$S_{xt-req} = M_{max}/(F_{y-bp} \cdot .67)$ (in ³)	0.00
$t_{t,req} = (6S_{xt-req})^{1/2}$ (in)	0.14
Plate Required:	4"x4"x0.5"



Micropile Design Calculator

V1.0

Design References: ACI 318-14; 2015 IBC; AISC Steel Construction Manual 14th ED.

Project: Lot 44 Powder Mountain P1-P8 Foundations
 Description: 150 kip ult micropile with 5"x5"x1.25" plate
 Date: 2/21/19
 Designed By: MJH

Checked By: POD

- Objectives: 1. Determine required bearing plate area, A_b
 2. Determine required bearing plate thickness, t_{req}

Loads

Ultimate Axial Design Comp. Load, P_c (kips)	150.0
Ultimate Axial Design Tension Load, P_t (kips)	1.0
Allowable Axial Design Comp. Load, P_c/SF (kips)	100.0
Allowable Axial Design Tension Load, P_t/SF (kips)	0.7

Safety Factor

SF= 1.5

Material Properties & Geometry

Grout		Micropile Tendon		Bearing Plate	
f'_c (ksi)	4	Bar Size	#11	f_{y-bp} (ksi)	36
Bit Diameter, D (in)	8	f_y (ksi)	75.00	Nut Diameter, D_n (in)	2.25
Assumed Grout Diameter, D' (in)	8	A_s (in ²)	1.41 (reduced by corrosion)		
		OD (in)	1.38		

Allowable Structural Strength

Allowable Comp. Steel, $P_{c(s)} = 0.4 \cdot f_y \cdot A'_s$ (kips)	42.3	Check Allowable > Load » COMPRESSION IS OK » TENSION IS OK
Allowable Comp. Grout, $P_{c(g)} = 0.33 \cdot f'_c \cdot A_c$ (kips)	64.5	
Allowable Comp. Strength, $P_c = P_{c(s)} + P_{c(g)}$ (kips)	106.8	
Allowable Tension Steel, $P_{t(s)} = 0.6 \cdot f_y \cdot A'_s$ (kips)	63.5	

Corrosion Rate/Sacrificial Steel

Maximum Steel Loss Rate* (mil/yr)	0.472
Structure Design Life (yrs)	75
Sacrificial Steel (in)	0.035

Equivalent to 12 μ m/yr

1. Req'd Plate Bearing Area

ACI 318-08 10.14.1

Bearing Plate Area for Compression

Req'd Bearing Area, A_{bc} (in ²)	21.00
$A_{bc} = ((P_c - P_{c(g)}) \cdot \Omega) / (0.85 \cdot f'_c) / (A_2/A_1)^{1/2}$ $(A_2/A_1)^{1/2} = 2$	
Use: A_{Bc} (in ²)	25

Bearing Plate Area for Tension

Req'd Bearing Area, A_{bt} (in ²)	1.73
$A_{bt} = ((P_t) \cdot \Omega) / (0.85 \cdot f_y) / (A_2/A_1)^{1/2} + \pi \cdot OD^2 / 4$ $(A_2/A_1)^{1/2} = 2$	
Use: A_{Bt} (in ²)	16



Micropile Design Calculator

V1.0

Design References: ACI 318-14; 2015 IBC; AISC Steel Construction Manual 14th ED.

Project: Lot 44 Powder Mountain P1-P8 Foundations
 Description: 150 kip ult micropile with 5"x5"x1.25" plate
 Date: 2/21/19
 Designed By: MJH

Checked By: POD

2. Req'd Bearing Plate Thickness

Plate Thickness for Compression

$M_{max} = wl^2/2$ (k-in)	5.40
$w = \Omega_b \cdot (P_c - P_{c(g)})/A_B$ (k/in)	5.71
$I = (A_{Bc}^{1/2} - D_n)/2$ (in)	1.38
$S_{xc-req} = M_{max}/(F_{y-bp} \cdot .67)$ (in ³)	0.22
$t_{c,req} = (6S_{xc-req})^{1/2}$ (in)	1.16
Plate Required:	5'x5'x1.25"

Plate Thickness for Tension

$M_{max} = wl^2/2$ (k-in)	0.04
$w = \Omega_b \cdot P/A_B$ (k/in)	0.10
$I = (A_{Bt}^{1/2} - D_n)/2$ (in)	0.88
$S_{xt-req} = M_{max}/(F_{y-bp} \cdot .67)$ (in ³)	0.00
$t_{t,req} = (6S_{xt-req})^{1/2}$ (in)	0.10
Plate Required:	4"x4"x0.5"



Micropile Design Calculator

V1.0

Design References: ACI 318-14; 2015 IBC; AISC Steel Construction Manual 14th ED.

Project: Lot 44 Powder Mountain P9 & P10 Foundations
 Description: 100 kip ult micropile with 4"x4"x1" plate
 Date: 2/21/19
 Designed By: MJH

Checked By: POD

- Objectives: 1. Determine required bearing plate area, A_b
 2. Determine required bearing plate thickness, t_{req}

Loads

Ultimate Axial Design Comp. Load, P_c (kips)	100.0
Ultimate Axial Design Tension Load, P_t (kips)	1.0
Allowable Axial Design Comp. Load, P_c/SF (kips)	66.7
Allowable Axial Design Tension Load, P_t/SF (kips)	0.7

Safety Factor

SF = 1.5

Material Properties & Geometry

Grout		Micropile Tendon		Bearing Plate	
f'_c (ksi)	4	Bar Size	#8	f_{y-bp} (ksi)	36
Bit Diameter, D (in)	8	f_y (ksi)	75.00	Nut Diameter, D_n (in)	1.63
Assumed Grout Diameter, D' (in)	8	A_s (in ²)	0.68 (reduced by corrosion)		
		OD (in)	1.00		

Allowable Structural Strength

Allowable Comp. Steel, $P_{c(s)} = 0.4 \cdot f_y \cdot A'_s$ (kips)	20.5	Check Allowable > Load » COMPRESSION IS OK » TENSION IS OK
Allowable Comp. Grout, $P_{c(g)} = 0.33 \cdot f'_c \cdot A_c$ (kips)	65.4	
Allowable Comp. Strength, $P_c = P_{c(s)} + P_{c(g)}$ (kips)	85.9	
Allowable Tension Steel, $P_{t(s)} = 0.6 \cdot f_y \cdot A'_s$ (kips)	30.7	

Corrosion Rate/Sacrificial Steel

Maximum Steel Loss Rate* (mil/yr)	0.472
Structure Design Life (yrs)	75
Sacrificial Steel (in)	0.035

Equivalent to 12 μ m/yr

1. Req'd Plate Bearing Area ACI 318-08 10.14.1

Bearing Plate Area for Compression

Req'd Bearing Area, A_{bc} (in ²)	8.49
$A_{bc} = ((P_c - P_{c(g)}) \cdot \Omega) / (0.85 \cdot f'_c) / (A_2/A_1)^{1/2}$ $(A_2/A_1)^{1/2} = 2$	
Use: A_{Bc} (in ²)	16

Bearing Plate Area for Tension

Req'd Bearing Area, A_{bt} (in ²)	1.03
$A_{bt} = ((P_t) \cdot \Omega) / (0.85 \cdot f_y) / (A_2/A_1)^{1/2} + \pi \cdot OD^2 / 4$ $(A_2/A_1)^{1/2} = 2$	
Use: A_{Bt} (in ²)	16



Micropile Design Calculator

V1.0

Design References: ACI 318-14; 2015 IBC; AISC Steel Construction Manual 14th ED.

Project: Lot 44 Powder Mountain P9 & P10 Foundations

Description: 100 kip ult micropile with 4"x4"x1" plate

Date: 2/21/19

Designed By: MJH

Checked By: POD

2. Req'd Bearing Plate Thickness

Plate Thickness for Compression

$M_{max} = wl^2/2$ (k-in)	2.54
$w = \Omega_b \cdot (P_c - P_{c(g)})/A_B$ (k/in)	3.61
$I = (A_{Bc}^{1/2} - D_n)/2$ (in)	1.19
$S_{xc-req} = M_{max}/(F_{y-bp} \cdot .67)$ (in ³)	0.11
$t_{c,req} = (6S_{xc-req})^{1/2}$ (in)	0.80
Plate Required:	4"x4"x1"

Plate Thickness for Tension

$M_{max} = wl^2/2$ (k-in)	0.07
$w = \Omega_b \cdot P/A_B$ (k/in)	0.10
$I = (A_{Bt}^{1/2} - D_n)/2$ (in)	1.19
$S_{xt-req} = M_{max}/(F_{y-bp} \cdot .67)$ (in ³)	0.00
$t_{t,req} = (6S_{xt-req})^{1/2}$ (in)	0.14
Plate Required:	4"x4"x0.5"

Concrete poured into drilled hole.
Diameter is limited to 24in (61cm).

FOUNDATION PROFILE & SOIL CONDITIONS

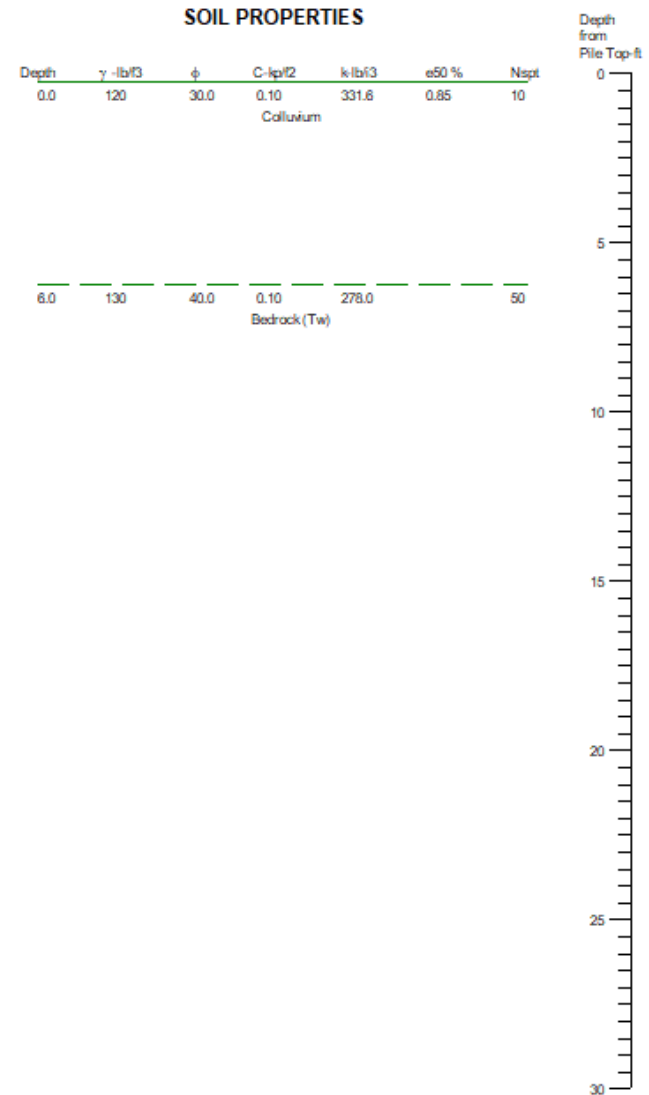
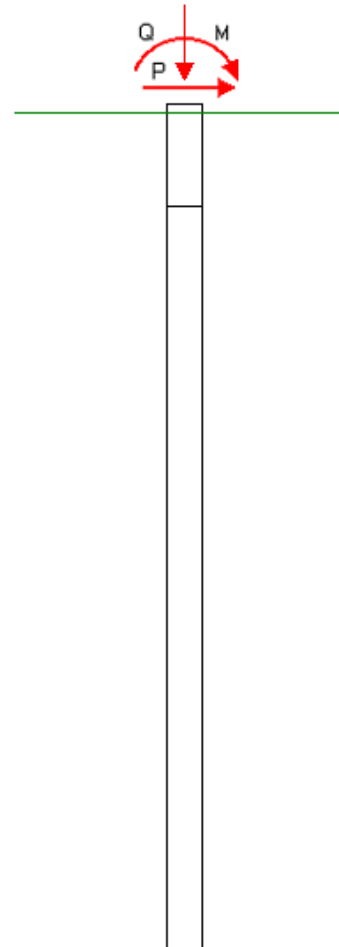
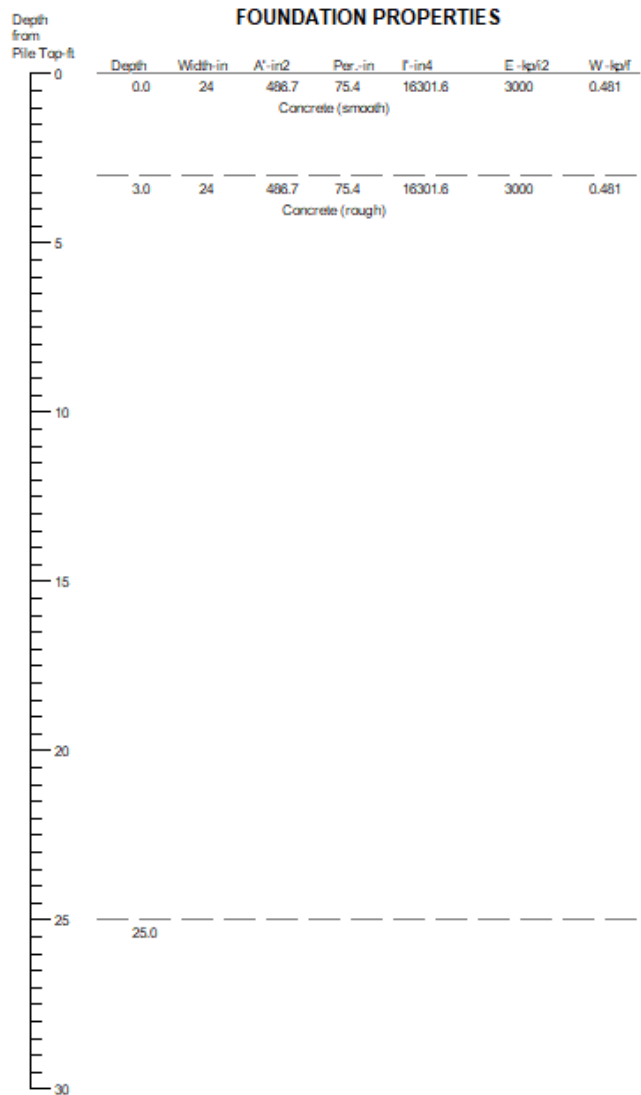

Batter Angle=0

(Pile diameter not to scale)

Surface Angle=0



**CivilTech
Software**

**Lot 44
Foundations P1-P8**

Figure 1

VERTICAL ANALYSIS

Figure 1

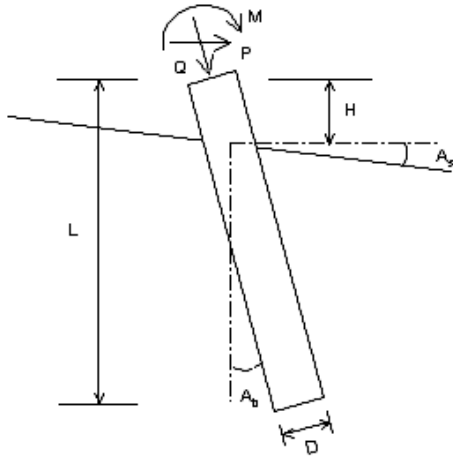

Drilled Pile (dia ≤ 24 in. or 61 cm)

Loads:

Load Factor for Vertical Loads= 1.0
 Load Factor for Lateral Loads= 1.0
 Loads Supported by Pile Cap= 0 %
 Shear Condition: Static

(with Load Factor)

Vertical Load, Q= 460.0 -kp
 Shear Load, P= 40.0 -kp
 Slope Restrain St= 0.00000 -in/in

Profile:

Pile Length, L= 25.0 -ft
 Top Height, H= 0.25 -ft
 Slope Angle, As= 0
 Batter Angle, Ab= 0
 Fixed Head Condition

Soil Data:

Depth -ft	Gamma -lb/f3	Phi	C -kp/f2	K -lb/i3	e50 or Dr %	Nspt
0	120	30.0	0.10	331.6	0.85	10
6	130	40.0	0.10	278.0	85.61	50

Pile Data:

Depth -ft	Width -in	Area -in2	Per. -in	I -in4	E -kp/i2	Weight -kp/f
0.0	24	486.7	75.4	16301.6	3000	0.481
3.0	24	486.7	75.4	16301.6	3000	0.481
25.0						

Vertical Capacity:

Weight above Ground= 0.12 Total Weight= 12.02-kp *Soil Weight is not included
 Side Resistance (Down)= 122.263-kp Side Resistance (Up)= 77.692-kp
 Tip Resistance (Down)= 717.720-kp Tip Resistance (Up)= 0.000-kp
 Total Ultimate Capacity (Down) Qult= 839.983-kp Total Ultimate Capacity (Up)= 89.717-kp
 Total Allowable Capacity (Down) Qallow= 440.369-kp Total Allowable Capacity (Up) Qallow= 50.871-kp
 N/G! Qallow < Q

Settlement Calculation:

At Q= 460.00-kp Settlement= 0.71919-in
 At Xallow= 1.00-in Q= 557.05322-kp

Note: If the program cannot find a result or the result exceeds the upper limit. The result will be displayed as 99999.



**CivilTech
Software**

**Lot 44
Foundations P1-P8**

Øsummary

ALLPILE 7
VERTICAL ANALYSIS SUMMARY OUTPUT
Copyright by CivilTech Software
www.civiltech.com

TOTAL LOADS:

Vertical Load, Q: 460.0 -kp
Vertical Load with Load Factor, Q: 460.0 -kp
Vertical Load with Load factor and Pile Cap, Q= 460.0 -kp
Load Factor for Vertical Load and Torsion= 1.0
Vertical Loads Supported by Pile Cap: 0 %
Load Factor for Vertical Loads: 1.0

PILE PROFILE:

Pile Length, L= 25.0 -ft
Top Height, H= 0.25 -ft
Slope Angle, As= 0
Batter Angle, Ab= 0.00 Batter Factor, Kbat= 1.00

SINGLE PILE:

Kdown= 0.7 Kup= 0.4 Ka= 1.17

Single Pile Vertical Analysis:

Total Ultimate Capacity (Down)= 839.983-kp Total Ultimate Capacity (Up)= 89.717-kp
Total Allowable Capacity (Down)= 440.369-kp Total Allowable Capacity (Up)= 50.871-kp

Weight above Ground= 0.12 Total Weight= 12.02-kp *Soil Weight is not included
Side Resistance (Down)= 122.263-kp Side Resistance (Up)= 77.692-kp
Tip Resistance (Down)= 717.720-kp Tip Resistance (Up)= 0.000-kp
Negative Friction, Qneg= 0.000-kp, which has been subtracted from Total Ultimate Capacity (Down)
Negative friction does not affect Total Ultimate Capacity (Up)

At Work Load= 460.00-kp, Settlement= 0.71919-in
At Work Load= 460.00-kp, Secant Stiffness Kqx= 639.60-kp/-in
At Allowable Settlement= 1.000000-in, Capacity= 557.05-kp
Work Load, 460.00-kp, OK with the Capacity at Allowable Settlement= 1.00000-in, Capacity= 557.05-kp
!!! Work Load, 460.00-kp, Exceeds the Allowable Capacity (Down)= 440.37-kp

FACTOR OF SAFETY:

FSside FStip FSuplif FSweight
1.5 2.0 2.0 1.0

Note: If the program cannot find a result or the result exceeds the upper limit. The result will be displayed as 99999.

1 1 1 1 1

0detail

ALLPILE 7
 VERTICAL ANALYSIS DETAILED OUTPUT
 Copyright by CivilTech Software
 www.civiltech.com

Pile Profile and Loading:

Piletype: Drilled Pile (dia <=24 in. or 61 cm)
 Pile Length, L= 25.0 -ft
 Top Height, H= 0.25 -ft
 Slope Angle, As= 0
 Batter Angle, Ab= 0.00

Single Pile, Vertical Analysis:

Vertical Load with Load factor, Q= 460.0 -kp
 Vertical Load with Load factor and Pile Cap, Q= 460.0 -kp
 Load Factor for Vertical Loads= 1.0
 Vertical Loads Supported by Pile Cap: 0 %
 Kdown= 0.7 Kup= 0.4 Ka= 1.17

Bearing stratum from pile tip extending to 10 Diameter of pile, which is=20.0-ft Starting from Pile Tip= 24.8-ft
 From Ztip=24.8 to 44.8-ft Average Properties: Es= 799.92-kp/f2 C=0.10-kp/f2 Friction=40.00 Cp=0.14 Ksand=1.00
 Limits of Max. tip resistance, q_lim= N/A
 Batter Angle, Ab= 0.00 Batter Factor, Kbat= 1.00
 Qtip_dw=717.7-kp based on qult=228.5-kp/f2 and Base Area=3.1-ft2
 Qtip_up=0.0-kp and Base Area=0.0-ft2

TIP RESISTANCE (Down) CALCULATION:

Tip Depth= 24.8-ft Critical Depth Ratio Z/D= 20 Critical Depth= 40.0-ft
 Equivalent Width of Tip= 2.00-ft, Tip Area= 3.14-ft2 Tip Diameter= 2.00-ft
 Bearing stratum from pile tip extending to 10 Diameter of pile. Bearing stratum= 20.00-ft
 Btip: width at pile tip= 2.00-ft (For group pile, it is equivalent width).
 Phi & C are average value in bearing stratum.
 Batter Angle= 0.00, Batter Factor for Tip and Side= 1.00

Ztip -ft	Z/D	Z_lim -ft	q_lim -kp/f2	Width -ft	Area' -ft2	Phi - o	C -kp/f2	Nq	Nc	Sv -kp/f2	qult -kp/f2	Qtip_dw -kp
24.8	20.0	40.0	N/A	2.00	3.14	40.0	0.10	72.0	9.0	3.2	228.5	717.7

Ztip - Depth of pile tip from ground surface (Zs)
 D - Pile average diameter (below ground) for calculation of critical depth. D=2.00-ft
 Z/D - Critical depth (for tip resistances) as ratio of depth/diameter. Vertical stress will be constant below critical depth
 Z_lim - Critical depth, calculated from Z/D (for tip resistances)
 q_lim - Limit of Maximum tip resistance
 Btip: width or diameter at pile tip
 Bearing stratum: A stratum from pile tip extending to some depth. Average soil properties in the stratum are used for bearing calculation

SIDE RESISTANCE (Uplift & Down) CALCULATION:

D -ft	Z/D	Z_lim -ft	Sf_lim -kp/f2	K_dw	K_up	dz -ft
2.00	20.0	40.00	N/A	0.7	0.4	0.050

D - Pile average diameter for calculation of critical depth
 Z/D - Critical depth (for side resistances) as ratio of depth/diameter. Vertical stress will be constant below critical depth
 Z_lim - Critical depth calculated from Z/D (for side resistances)
 Sf_lim - Limit of Maximum side resistance

SIDE RESISTANCE (Up & Down) CALCULATION vs DEPTH:

Calculation is based on segment dz= 0.05

Zs	Prem	Sv	Phi	Kf(<2)	Delta	f_dw	Ødetail f_up	C	Ka	Kc(<2)	Ca_dw	Ca_up	Sf_dw
Sf_up	Weight	Qneg	Q_dw	Q_up	Torsion	-kp/f2	-kp/f2	-kp/f2		Ca	-kp/f2	-kp/f2	-kp/f2
-ft	-ft	-kp/f2	- o	Delta	- o								
-kp/f2	-kp	-kp	-kp	-kp	-kp-f								
24.75	6.28	3.16	40.0	0.80	32.0	1.38	0.79	0.10	1.17	1.00	0.12	0.12	0.00
0.00	0.00	0.00	717.7	0.0	0.0								
24.70	6.28	3.15	40.0	0.80	32.0	1.38	0.79	0.10	1.17	1.00	0.12	0.12	1.50
0.91	0.02	0.00	718.2	0.3	0.4								
24.65	6.28	3.15	40.0	0.80	32.0	1.38	0.79	0.10	1.17	1.00	0.12	0.12	1.49
0.90	0.05	0.00	718.7	0.6	0.7								
24.60	6.28	3.14	40.0	0.80	32.0	1.37	0.79	0.10	1.17	1.00	0.12	0.12	1.49
0.90	0.07	0.00	719.1	0.9	1.1								
24.55	6.28	3.13	40.0	0.80	32.0	1.37	0.78	0.10	1.17	1.00	0.12	0.12	1.49
0.90	0.10	0.00	719.6	1.2	1.5								
24.50	6.28	3.13	40.0	0.80	32.0	1.37	0.78	0.10	1.17	1.00	0.12	0.12	1.49
0.90	0.12	0.00	720.0	1.5	1.9								
24.45	6.28	3.12	40.0	0.80	32.0	1.37	0.78	0.10	1.17	1.00	0.12	0.12	1.48
0.90	0.14	0.00	720.5	1.8	2.2								
24.40	6.28	3.12	40.0	0.80	32.0	1.36	0.78	0.10	1.17	1.00	0.12	0.12	1.48
0.90	0.17	0.00	721.0	2.1	2.6								
24.35	6.28	3.11	40.0	0.80	32.0	1.36	0.78	0.10	1.17	1.00	0.12	0.12	1.48
0.89	0.19	0.00	721.4	2.4	3.0								
24.30	6.28	3.10	40.0	0.80	32.0	1.36	0.78	0.10	1.17	1.00	0.12	0.12	1.47
0.89	0.21	0.00	721.9	2.7	3.3								
24.25	6.28	3.10	40.0	0.80	32.0	1.35	0.77	0.10	1.17	1.00	0.12	0.12	1.47
0.89	0.24	0.00	722.3	3.0	3.7								
24.20	6.28	3.09	40.0	0.80	32.0	1.35	0.77	0.10	1.17	1.00	0.12	0.12	1.47
0.89	0.26	0.00	722.8	3.3	4.1								
24.15	6.28	3.08	40.0	0.80	32.0	1.35	0.77	0.10	1.17	1.00	0.12	0.12	1.47
0.89	0.29	0.00	723.3	3.6	4.4								
24.11	6.28	3.08	40.0	0.80	32.0	1.35	0.77	0.10	1.17	1.00	0.12	0.12	1.46
0.89	0.31	0.00	723.7	3.9	4.8								
24.06	6.28	3.07	40.0	0.80	32.0	1.34	0.77	0.10	1.17	1.00	0.12	0.12	1.46
0.88	0.33	0.00	724.2	4.2	5.2								
24.01	6.28	3.06	40.0	0.80	32.0	1.34	0.77	0.10	1.17	1.00	0.12	0.12	1.46
0.88	0.36	0.00	724.6	4.5	5.5								
23.96	6.28	3.06	40.0	0.80	32.0	1.34	0.76	0.10	1.17	1.00	0.12	0.12	1.45
0.88	0.38	0.00	725.1	4.8	5.9								
23.91	6.28	3.05	40.0	0.80	32.0	1.33	0.76	0.10	1.17	1.00	0.12	0.12	1.45
0.88	0.41	0.00	725.5	5.1	6.3								
23.86	6.28	3.04	40.0	0.80	32.0	1.33	0.76	0.10	1.17	1.00	0.12	0.12	1.45
0.88	0.43	0.00	726.0	5.4	6.6								
23.81	6.28	3.04	40.0	0.80	32.0	1.33	0.76	0.10	1.17	1.00	0.12	0.12	1.45
0.88	0.45	0.00	726.4	5.7	7.0								
23.76	6.28	3.03	40.0	0.80	32.0	1.33	0.76	0.10	1.17	1.00	0.12	0.12	1.44
0.88	0.48	0.00	726.9	6.0	7.4								
23.71	6.28	3.03	40.0	0.80	32.0	1.32	0.76	0.10	1.17	1.00	0.12	0.12	1.44
0.87	0.50	0.00	727.3	6.3	7.7								
23.66	6.28	3.02	40.0	0.80	32.0	1.32	0.75	0.10	1.17	1.00	0.12	0.12	1.44
0.87	0.52	0.00	727.8	6.6	8.1								
23.61	6.28	3.01	40.0	0.80	32.0	1.32	0.75	0.10	1.17	1.00	0.12	0.12	1.43
0.87	0.55	0.00	728.2	6.9	8.4								
23.56	6.28	3.01	40.0	0.80	32.0	1.31	0.75	0.10	1.17	1.00	0.12	0.12	1.43
0.87	0.57	0.00	728.7	7.2	8.8								
23.51	6.28	3.00	40.0	0.80	32.0	1.31	0.75	0.10	1.17	1.00	0.12	0.12	1.43
0.87	0.60	0.00	729.1	7.5	9.2								
23.46	6.28	2.99	40.0	0.80	32.0	1.31	0.75	0.10	1.17	1.00	0.12	0.12	1.43
0.87	0.62	0.00	729.6	7.8	9.5								
23.41	6.28	2.99	40.0	0.80	32.0	1.31	0.75	0.10	1.17	1.00	0.12	0.12	1.42
0.86	0.64	0.00	730.0	8.1	9.9								
23.36	6.28	2.98	40.0	0.80	32.0	1.30	0.74	0.10	1.17	1.00	0.12	0.12	1.42
0.86	0.67	0.00	730.5	8.4	10.2								
23.31	6.28	2.97	40.0	0.80	32.0	1.30	0.74	0.10	1.17	1.00	0.12	0.12	1.42
0.86	0.69	0.00	730.9	8.7	10.6								
23.26	6.28	2.97	40.0	0.80	32.0	1.30	0.74	0.10	1.17	1.00	0.12	0.12	1.42

Ødetail

0.86	0.72	0.00	731.3	9.0	10.9								
23.21	6.28	2.96	40.0	0.80	32.0	1.29	0.74	0.10	1.17	1.00	0.12	0.12	1.41
0.86	0.74	0.00	731.8	9.3	11.3								
23.16	6.28	2.95	40.0	0.80	32.0	1.29	0.74	0.10	1.17	1.00	0.12	0.12	1.41
0.86	0.76	0.00	732.2	9.5	11.6								
23.11	6.28	2.95	40.0	0.80	32.0	1.29	0.74	0.10	1.17	1.00	0.12	0.12	1.41
0.85	0.79	0.00	732.7	9.8	12.0								
23.06	6.28	2.94	40.0	0.80	32.0	1.29	0.74	0.10	1.17	1.00	0.12	0.12	1.40
0.85	0.81	0.00	733.1	10.1	12.3								
23.01	6.28	2.93	40.0	0.80	32.0	1.28	0.73	0.10	1.17	1.00	0.12	0.12	1.40
0.85	0.84	0.00	733.5	10.4	12.7								
22.96	6.28	2.93	40.0	0.80	32.0	1.28	0.73	0.10	1.17	1.00	0.12	0.12	1.40
0.85	0.86	0.00	734.0	10.7	13.0								
22.91	6.28	2.92	40.0	0.80	32.0	1.28	0.73	0.10	1.17	1.00	0.12	0.12	1.40
0.85	0.88	0.00	734.4	11.0	13.4								
22.87	6.28	2.92	40.0	0.80	32.0	1.28	0.73	0.10	1.17	1.00	0.12	0.12	1.39
0.85	0.91	0.00	734.8	11.3	13.7								
22.82	6.28	2.91	40.0	0.80	32.0	1.27	0.73	0.10	1.17	1.00	0.12	0.12	1.39
0.84	0.93	0.00	735.3	11.6	14.1								
22.77	6.28	2.90	40.0	0.80	32.0	1.27	0.73	0.10	1.17	1.00	0.12	0.12	1.39
0.84	0.95	0.00	735.7	11.9	14.4								
22.72	6.28	2.90	40.0	0.80	32.0	1.27	0.72	0.10	1.17	1.00	0.12	0.12	1.38
0.84	0.98	0.00	736.1	12.1	14.8								
22.67	6.28	2.89	40.0	0.80	32.0	1.26	0.72	0.10	1.17	1.00	0.12	0.12	1.38
0.84	1.00	0.00	736.6	12.4	15.1								
22.62	6.28	2.88	40.0	0.80	32.0	1.26	0.72	0.10	1.17	1.00	0.12	0.12	1.38
0.84	1.03	0.00	737.0	12.7	15.5								
22.57	6.28	2.88	40.0	0.80	32.0	1.26	0.72	0.10	1.17	1.00	0.12	0.12	1.38
0.84	1.05	0.00	737.4	13.0	15.8								
22.52	6.28	2.87	40.0	0.80	32.0	1.26	0.72	0.10	1.17	1.00	0.12	0.12	1.37
0.83	1.07	0.00	737.8	13.3	16.2								
22.47	6.28	2.86	40.0	0.80	32.0	1.25	0.72	0.10	1.17	1.00	0.12	0.12	1.37
0.83	1.10	0.00	738.3	13.6	16.5								
22.42	6.28	2.86	40.0	0.80	32.0	1.25	0.71	0.10	1.17	1.00	0.12	0.12	1.37
0.83	1.12	0.00	738.7	13.8	16.9								
22.37	6.28	2.85	40.0	0.80	32.0	1.25	0.71	0.10	1.17	1.00	0.12	0.12	1.36
0.83	1.15	0.00	739.1	14.1	17.2								
22.32	6.28	2.84	40.0	0.80	32.0	1.24	0.71	0.10	1.17	1.00	0.12	0.12	1.36
0.83	1.17	0.00	739.5	14.4	17.5								
22.27	6.28	2.84	40.0	0.80	32.0	1.24	0.71	0.10	1.17	1.00	0.12	0.12	1.36
0.83	1.19	0.00	740.0	14.7	17.9								
22.22	6.28	2.83	40.0	0.80	32.0	1.24	0.71	0.10	1.17	1.00	0.12	0.12	1.36
0.83	1.22	0.00	740.4	15.0	18.2								
22.17	6.28	2.83	40.0	0.80	32.0	1.24	0.71	0.10	1.17	1.00	0.12	0.12	1.35
0.82	1.24	0.00	740.8	15.3	18.6								
22.12	6.28	2.82	40.0	0.80	32.0	1.23	0.70	0.10	1.17	1.00	0.12	0.12	1.35
0.82	1.26	0.00	741.2	15.5	18.9								
22.07	6.28	2.81	40.0	0.80	32.0	1.23	0.70	0.10	1.17	1.00	0.12	0.12	1.35
0.82	1.29	0.00	741.7	15.8	19.2								
22.02	6.28	2.81	40.0	0.80	32.0	1.23	0.70	0.10	1.17	1.00	0.12	0.12	1.34
0.82	1.31	0.00	742.1	16.1	19.6								
21.97	6.28	2.80	40.0	0.80	32.0	1.22	0.70	0.10	1.17	1.00	0.12	0.12	1.34
0.82	1.34	0.00	742.5	16.4	19.9								
21.92	6.28	2.79	40.0	0.80	32.0	1.22	0.70	0.10	1.17	1.00	0.12	0.12	1.34
0.82	1.36	0.00	742.9	16.6	20.2								
21.87	6.28	2.79	40.0	0.80	32.0	1.22	0.70	0.10	1.17	1.00	0.12	0.12	1.34
0.81	1.38	0.00	743.3	16.9	20.6								
21.82	6.28	2.78	40.0	0.80	32.0	1.22	0.69	0.10	1.17	1.00	0.12	0.12	1.33
0.81	1.41	0.00	743.7	17.2	20.9								
21.77	6.28	2.77	40.0	0.80	32.0	1.21	0.69	0.10	1.17	1.00	0.12	0.12	1.33
0.81	1.43	0.00	744.2	17.5	21.2								
21.72	6.28	2.77	40.0	0.80	32.0	1.21	0.69	0.10	1.17	1.00	0.12	0.12	1.33
0.81	1.46	0.00	744.6	17.8	21.6								
21.67	6.28	2.76	40.0	0.80	32.0	1.21	0.69	0.10	1.17	1.00	0.12	0.12	1.32
0.81	1.48	0.00	745.0	18.0	21.9								
21.63	6.28	2.75	40.0	0.80	32.0	1.20	0.69	0.10	1.17	1.00	0.12	0.12	1.32
0.81	1.50	0.00	745.4	18.3	22.2								

												Ødetail	
21.58	6.28	2.75	40.0	0.80	32.0	1.20	0.69	0.10	1.17	1.00	0.12	0.12	1.32
0.80	1.53	0.00	745.8	18.6	22.6								
21.53	6.28	2.74	40.0	0.80	32.0	1.20	0.69	0.10	1.17	1.00	0.12	0.12	1.32
0.80	1.55	0.00	746.2	18.9	22.9								
21.48	6.28	2.73	40.0	0.80	32.0	1.20	0.68	0.10	1.17	1.00	0.12	0.12	1.31
0.80	1.57	0.00	746.6	19.1	23.2								
21.43	6.28	2.73	40.0	0.80	32.0	1.19	0.68	0.10	1.17	1.00	0.12	0.12	1.31
0.80	1.60	0.00	747.0	19.4	23.6								
21.38	6.28	2.72	40.0	0.80	32.0	1.19	0.68	0.10	1.17	1.00	0.12	0.12	1.31
0.80	1.62	0.00	747.4	19.7	23.9								
21.33	6.28	2.72	40.0	0.80	32.0	1.19	0.68	0.10	1.17	1.00	0.12	0.12	1.31
0.80	1.65	0.00	747.8	19.9	24.2								
21.28	6.28	2.71	40.0	0.80	32.0	1.18	0.68	0.10	1.17	1.00	0.12	0.12	1.30
0.79	1.67	0.00	748.3	20.2	24.5								
21.23	6.28	2.70	40.0	0.80	32.0	1.18	0.68	0.10	1.17	1.00	0.12	0.12	1.30
0.79	1.69	0.00	748.7	20.5	24.9								
21.18	6.28	2.70	40.0	0.80	32.0	1.18	0.67	0.10	1.17	1.00	0.12	0.12	1.30
0.79	1.72	0.00	749.1	20.8	25.2								
21.13	6.28	2.69	40.0	0.80	32.0	1.18	0.67	0.10	1.17	1.00	0.12	0.12	1.29
0.79	1.74	0.00	749.5	21.0	25.5								
21.08	6.28	2.68	40.0	0.80	32.0	1.17	0.67	0.10	1.17	1.00	0.12	0.12	1.29
0.79	1.77	0.00	749.9	21.3	25.8								
21.03	6.28	2.68	40.0	0.80	32.0	1.17	0.67	0.10	1.17	1.00	0.12	0.12	1.29
0.79	1.79	0.00	750.3	21.6	26.2								
20.98	6.28	2.67	40.0	0.80	32.0	1.17	0.67	0.10	1.17	1.00	0.12	0.12	1.29
0.78	1.81	0.00	750.7	21.8	26.5								
20.93	6.28	2.66	40.0	0.80	32.0	1.17	0.67	0.10	1.17	1.00	0.12	0.12	1.28
0.78	1.84	0.00	751.1	22.1	26.8								
20.88	6.28	2.66	40.0	0.80	32.0	1.16	0.66	0.10	1.17	1.00	0.12	0.12	1.28
0.78	1.86	0.00	751.5	22.4	27.1								
20.83	6.28	2.65	40.0	0.80	32.0	1.16	0.66	0.10	1.17	1.00	0.12	0.12	1.28
0.78	1.88	0.00	751.9	22.6	27.5								
20.78	6.28	2.64	40.0	0.80	32.0	1.16	0.66	0.10	1.17	1.00	0.12	0.12	1.27
0.78	1.91	0.00	752.3	22.9	27.8								
20.73	6.28	2.64	40.0	0.80	32.0	1.15	0.66	0.10	1.17	1.00	0.12	0.12	1.27
0.78	1.93	0.00	752.7	23.2	28.1								
20.68	6.28	2.63	40.0	0.80	32.0	1.15	0.66	0.10	1.17	1.00	0.12	0.12	1.27
0.78	1.96	0.00	753.1	23.4	28.4								
20.63	6.28	2.63	40.0	0.80	32.0	1.15	0.66	0.10	1.17	1.00	0.12	0.12	1.27
0.77	1.98	0.00	753.5	23.7	28.7								
20.58	6.28	2.62	40.0	0.80	32.0	1.15	0.65	0.10	1.17	1.00	0.12	0.12	1.26
0.77	2.00	0.00	753.8	24.0	29.0								
20.53	6.28	2.61	40.0	0.80	32.0	1.14	0.65	0.10	1.17	1.00	0.12	0.12	1.26
0.77	2.03	0.00	754.2	24.2	29.4								
20.48	6.28	2.61	40.0	0.80	32.0	1.14	0.65	0.10	1.17	1.00	0.12	0.12	1.26
0.77	2.05	0.00	754.6	24.5	29.7								
20.43	6.28	2.60	40.0	0.80	32.0	1.14	0.65	0.10	1.17	1.00	0.12	0.12	1.25
0.77	2.08	0.00	755.0	24.8	30.0								
20.39	6.28	2.59	40.0	0.80	32.0	1.13	0.65	0.10	1.17	1.00	0.12	0.12	1.25
0.77	2.10	0.00	755.4	25.0	30.3								
20.34	6.28	2.59	40.0	0.80	32.0	1.13	0.65	0.10	1.17	1.00	0.12	0.12	1.25
0.76	2.12	0.00	755.8	25.3	30.6								
20.29	6.28	2.58	40.0	0.80	32.0	1.13	0.64	0.10	1.17	1.00	0.12	0.12	1.25
0.76	2.15	0.00	756.2	25.5	30.9								
20.24	6.28	2.57	40.0	0.80	32.0	1.13	0.64	0.10	1.17	1.00	0.12	0.12	1.24
0.76	2.17	0.00	756.6	25.8	31.2								
20.19	6.28	2.57	40.0	0.80	32.0	1.12	0.64	0.10	1.17	1.00	0.12	0.12	1.24
0.76	2.19	0.00	757.0	26.1	31.6								
20.14	6.28	2.56	40.0	0.80	32.0	1.12	0.64	0.10	1.17	1.00	0.12	0.12	1.24
0.76	2.22	0.00	757.3	26.3	31.9								
20.09	6.28	2.55	40.0	0.80	32.0	1.12	0.64	0.10	1.17	1.00	0.12	0.12	1.23
0.76	2.24	0.00	757.7	26.6	32.2								
20.04	6.28	2.55	40.0	0.80	32.0	1.11	0.64	0.10	1.17	1.00	0.12	0.12	1.23
0.75	2.27	0.00	758.1	26.8	32.5								
19.99	6.28	2.54	40.0	0.80	32.0	1.11	0.64	0.10	1.17	1.00	0.12	0.12	1.23
0.75	2.29	0.00	758.5	27.1	32.8								
19.94	6.28	2.54	40.0	0.80	32.0	1.11	0.63	0.10	1.17	1.00	0.12	0.12	1.23

Ødetail

0.75	2.31	0.00	758.9	27.4	33.1								
19.89	6.28	2.53	40.0	0.80	32.0	1.11	0.63	0.10	1.17	1.00	0.12	0.12	1.22
0.75	2.34	0.00	759.3	27.6	33.4								
19.84	6.28	2.52	40.0	0.80	32.0	1.10	0.63	0.10	1.17	1.00	0.12	0.12	1.22
0.75	2.36	0.00	759.6	27.9	33.7								
19.79	6.28	2.52	40.0	0.80	32.0	1.10	0.63	0.10	1.17	1.00	0.12	0.12	1.22
0.75	2.39	0.00	760.0	28.1	34.0								
19.74	6.28	2.51	40.0	0.80	32.0	1.10	0.63	0.10	1.17	1.00	0.12	0.12	1.22
0.74	2.41	0.00	760.4	28.4	34.3								
19.69	6.28	2.50	40.0	0.80	32.0	1.09	0.63	0.10	1.17	1.00	0.12	0.12	1.21
0.74	2.43	0.00	760.8	28.6	34.6								
19.64	6.28	2.50	40.0	0.80	32.0	1.09	0.62	0.10	1.17	1.00	0.12	0.12	1.21
0.74	2.46	0.00	761.2	28.9	34.9								
19.59	6.28	2.49	40.0	0.80	32.0	1.09	0.62	0.10	1.17	1.00	0.12	0.12	1.21
0.74	2.48	0.00	761.5	29.1	35.2								
19.54	6.28	2.48	40.0	0.80	32.0	1.09	0.62	0.10	1.17	1.00	0.12	0.12	1.20
0.74	2.51	0.00	761.9	29.4	35.5								
19.49	6.28	2.48	40.0	0.80	32.0	1.08	0.62	0.10	1.17	1.00	0.12	0.12	1.20
0.74	2.53	0.00	762.3	29.7	35.8								
19.44	6.28	2.47	40.0	0.80	32.0	1.08	0.62	0.10	1.17	1.00	0.12	0.12	1.20
0.73	2.55	0.00	762.7	29.9	36.1								
19.39	6.28	2.46	40.0	0.80	32.0	1.08	0.62	0.10	1.17	1.00	0.12	0.12	1.20
0.73	2.58	0.00	763.0	30.2	36.4								
19.34	6.28	2.46	40.0	0.80	32.0	1.07	0.61	0.10	1.17	1.00	0.12	0.12	1.19
0.73	2.60	0.00	763.4	30.4	36.7								
19.29	6.28	2.45	40.0	0.80	32.0	1.07	0.61	0.10	1.17	1.00	0.12	0.12	1.19
0.73	2.62	0.00	763.8	30.7	37.0								
19.24	6.28	2.44	40.0	0.80	32.0	1.07	0.61	0.10	1.17	1.00	0.12	0.12	1.19
0.73	2.65	0.00	764.1	30.9	37.3								
19.19	6.28	2.44	40.0	0.80	32.0	1.07	0.61	0.10	1.17	1.00	0.12	0.12	1.18
0.73	2.67	0.00	764.5	31.2	37.6								
19.15	6.28	2.43	40.0	0.80	32.0	1.06	0.61	0.10	1.17	1.00	0.12	0.12	1.18
0.73	2.70	0.00	764.9	31.4	37.9								
19.10	6.28	2.43	40.0	0.80	32.0	1.06	0.61	0.10	1.17	1.00	0.12	0.12	1.18
0.72	2.72	0.00	765.2	31.7	38.2								
19.05	6.28	2.42	40.0	0.80	32.0	1.06	0.60	0.10	1.17	1.00	0.12	0.12	1.18
0.72	2.74	0.00	765.6	31.9	38.5								
19.00	6.28	2.41	40.0	0.80	32.0	1.06	0.60	0.10	1.17	1.00	0.12	0.12	1.17
0.72	2.77	0.00	766.0	32.2	38.8								
18.95	6.28	2.41	40.0	0.80	32.0	1.05	0.60	0.10	1.17	1.00	0.12	0.12	1.17
0.72	2.79	0.00	766.3	32.4	39.1								
18.90	6.28	2.40	40.0	0.80	32.0	1.05	0.60	0.10	1.17	1.00	0.12	0.12	1.17
0.72	2.82	0.00	766.7	32.7	39.4								
18.85	6.28	2.39	40.0	0.80	32.0	1.05	0.60	0.10	1.17	1.00	0.12	0.12	1.16
0.72	2.84	0.00	767.1	32.9	39.7								
18.80	6.28	2.39	40.0	0.80	32.0	1.04	0.60	0.10	1.17	1.00	0.12	0.12	1.16
0.71	2.86	0.00	767.4	33.2	40.0								
18.75	6.28	2.38	40.0	0.80	32.0	1.04	0.59	0.10	1.17	1.00	0.12	0.12	1.16
0.71	2.89	0.00	767.8	33.4	40.3								
18.70	6.28	2.37	40.0	0.80	32.0	1.04	0.59	0.10	1.17	1.00	0.12	0.12	1.16
0.71	2.91	0.00	768.2	33.6	40.6								
18.65	6.28	2.37	40.0	0.80	32.0	1.04	0.59	0.10	1.17	1.00	0.12	0.12	1.15
0.71	2.93	0.00	768.5	33.9	40.9								
18.60	6.28	2.36	40.0	0.80	32.0	1.03	0.59	0.10	1.17	1.00	0.12	0.12	1.15
0.71	2.96	0.00	768.9	34.1	41.2								
18.55	6.28	2.35	40.0	0.80	32.0	1.03	0.59	0.10	1.17	1.00	0.12	0.12	1.15
0.71	2.98	0.00	769.2	34.4	41.5								
18.50	6.28	2.35	40.0	0.80	32.0	1.03	0.59	0.10	1.17	1.00	0.12	0.12	1.14
0.70	3.01	0.00	769.6	34.6	41.7								
18.45	6.28	2.34	40.0	0.80	32.0	1.02	0.59	0.10	1.17	1.00	0.12	0.12	1.14
0.70	3.03	0.00	769.9	34.9	42.0								
18.40	6.28	2.34	40.0	0.80	32.0	1.02	0.58	0.10	1.17	1.00	0.12	0.12	1.14
0.70	3.05	0.00	770.3	35.1	42.3								
18.35	6.28	2.33	40.0	0.80	32.0	1.02	0.58	0.10	1.17	1.00	0.12	0.12	1.14
0.70	3.08	0.00	770.6	35.3	42.6								
18.30	6.28	2.32	40.0	0.80	32.0	1.02	0.58	0.10	1.17	1.00	0.12	0.12	1.13
0.70	3.10	0.00	771.0	35.6	42.9								

													Ødetail
18.25	6.28	2.32	40.0	0.80	32.0	1.01	0.58	0.10	1.17	1.00	0.12	0.12	1.13
0.70	3.13	0.00	771.4	35.8	43.2								
18.20	6.28	2.31	40.0	0.80	32.0	1.01	0.58	0.10	1.17	1.00	0.12	0.12	1.13
0.69	3.15	0.00	771.7	36.1	43.5								
18.15	6.28	2.30	40.0	0.80	32.0	1.01	0.58	0.10	1.17	1.00	0.12	0.12	1.12
0.69	3.17	0.00	772.1	36.3	43.7								
18.10	6.28	2.30	40.0	0.80	32.0	1.00	0.57	0.10	1.17	1.00	0.12	0.12	1.12
0.69	3.20	0.00	772.4	36.5	44.0								
18.05	6.28	2.29	40.0	0.80	32.0	1.00	0.57	0.10	1.17	1.00	0.12	0.12	1.12
0.69	3.22	0.00	772.8	36.8	44.3								
18.00	6.28	2.28	40.0	0.80	32.0	1.00	0.57	0.10	1.17	1.00	0.12	0.12	1.12
0.69	3.24	0.00	773.1	37.0	44.6								
17.95	6.28	2.28	40.0	0.80	32.0	1.00	0.57	0.10	1.17	1.00	0.12	0.12	1.11
0.69	3.27	0.00	773.4	37.3	44.9								
17.91	6.28	2.27	40.0	0.80	32.0	0.99	0.57	0.10	1.17	1.00	0.12	0.12	1.11
0.68	3.29	0.00	773.8	37.5	45.1								
17.86	6.28	2.26	40.0	0.80	32.0	0.99	0.57	0.10	1.17	1.00	0.12	0.12	1.11
0.68	3.32	0.00	774.1	37.7	45.4								
17.81	6.28	2.26	40.0	0.80	32.0	0.99	0.56	0.10	1.17	1.00	0.12	0.12	1.11
0.68	3.34	0.00	774.5	38.0	45.7								
17.76	6.28	2.25	40.0	0.80	32.0	0.98	0.56	0.10	1.17	1.00	0.12	0.12	1.10
0.68	3.36	0.00	774.8	38.2	46.0								
17.71	6.28	2.24	40.0	0.80	32.0	0.98	0.56	0.10	1.17	1.00	0.12	0.12	1.10
0.68	3.39	0.00	775.2	38.4	46.3								
17.66	6.28	2.24	40.0	0.80	32.0	0.98	0.56	0.10	1.17	1.00	0.12	0.12	1.10
0.68	3.41	0.00	775.5	38.7	46.5								
17.61	6.28	2.23	40.0	0.80	32.0	0.98	0.56	0.10	1.17	1.00	0.12	0.12	1.09
0.68	3.44	0.00	775.9	38.9	46.8								
17.56	6.28	2.23	40.0	0.80	32.0	0.97	0.56	0.10	1.17	1.00	0.12	0.12	1.09
0.67	3.46	0.00	776.2	39.1	47.1								
17.51	6.28	2.22	40.0	0.80	32.0	0.97	0.55	0.10	1.17	1.00	0.12	0.12	1.09
0.67	3.48	0.00	776.5	39.4	47.4								
17.46	6.28	2.21	40.0	0.80	32.0	0.97	0.55	0.10	1.17	1.00	0.12	0.12	1.09
0.67	3.51	0.00	776.9	39.6	47.6								
17.41	6.28	2.21	40.0	0.80	32.0	0.96	0.55	0.10	1.17	1.00	0.12	0.12	1.08
0.67	3.53	0.00	777.2	39.8	47.9								
17.36	6.28	2.20	40.0	0.80	32.0	0.96	0.55	0.10	1.17	1.00	0.12	0.12	1.08
0.67	3.55	0.00	777.5	40.1	48.2								
17.31	6.28	2.19	40.0	0.80	32.0	0.96	0.55	0.10	1.17	1.00	0.12	0.12	1.08
0.67	3.58	0.00	777.9	40.3	48.4								
17.26	6.28	2.19	40.0	0.80	32.0	0.96	0.55	0.10	1.17	1.00	0.12	0.12	1.07
0.66	3.60	0.00	778.2	40.5	48.7								
17.21	6.28	2.18	40.0	0.80	32.0	0.95	0.54	0.10	1.17	1.00	0.12	0.12	1.07
0.66	3.63	0.00	778.5	40.8	49.0								
17.16	6.28	2.17	40.0	0.80	32.0	0.95	0.54	0.10	1.17	1.00	0.12	0.12	1.07
0.66	3.65	0.00	778.9	41.0	49.3								
17.11	6.28	2.17	40.0	0.80	32.0	0.95	0.54	0.10	1.17	1.00	0.12	0.12	1.07
0.66	3.67	0.00	779.2	41.2	49.5								
17.06	6.28	2.16	40.0	0.80	32.0	0.95	0.54	0.10	1.17	1.00	0.12	0.12	1.06
0.66	3.70	0.00	779.5	41.5	49.8								
17.01	6.28	2.15	40.0	0.80	32.0	0.94	0.54	0.10	1.17	1.00	0.12	0.12	1.06
0.66	3.72	0.00	779.9	41.7	50.1								
16.96	6.28	2.15	40.0	0.80	32.0	0.94	0.54	0.10	1.17	1.00	0.12	0.12	1.06
0.65	3.75	0.00	780.2	41.9	50.3								
16.91	6.28	2.14	40.0	0.80	32.0	0.94	0.54	0.10	1.17	1.00	0.12	0.12	1.05
0.65	3.77	0.00	780.5	42.1	50.6								
16.86	6.28	2.14	40.0	0.80	32.0	0.93	0.53	0.10	1.17	1.00	0.12	0.12	1.05
0.65	3.79	0.00	780.9	42.4	50.9								
16.81	6.28	2.13	40.0	0.80	32.0	0.93	0.53	0.10	1.17	1.00	0.12	0.12	1.05
0.65	3.82	0.00	781.2	42.6	51.1								
16.76	6.28	2.12	40.0	0.80	32.0	0.93	0.53	0.10	1.17	1.00	0.12	0.12	1.05
0.65	3.84	0.00	781.5	42.8	51.4								
16.71	6.28	2.12	40.0	0.80	32.0	0.93	0.53	0.10	1.17	1.00	0.12	0.12	1.04
0.65	3.86	0.00	781.8	43.0	51.7								
16.67	6.28	2.11	40.0	0.80	32.0	0.92	0.53	0.10	1.17	1.00	0.12	0.12	1.04
0.64	3.89	0.00	782.2	43.3	51.9								
16.62	6.28	2.10	40.0	0.80	32.0	0.92	0.53	0.10	1.17	1.00	0.12	0.12	1.04

Ødetail

0.64	3.91	0.00	782.5	43.5	52.2								
16.57	6.28	2.10	40.0	0.80	32.0	0.92	0.52	0.10	1.17	1.00	0.12	0.12	1.03
0.64	3.94	0.00	782.8	43.7	52.4								
16.52	6.28	2.09	40.0	0.80	32.0	0.91	0.52	0.10	1.17	1.00	0.12	0.12	1.03
0.64	3.96	0.00	783.1	43.9	52.7								
16.47	6.28	2.08	40.0	0.80	32.0	0.91	0.52	0.10	1.17	1.00	0.12	0.12	1.03
0.64	3.98	0.00	783.5	44.2	53.0								
16.42	6.28	2.08	40.0	0.80	32.0	0.91	0.52	0.10	1.17	1.00	0.12	0.12	1.03
0.64	4.01	0.00	783.8	44.4	53.2								
16.37	6.28	2.07	40.0	0.80	32.0	0.91	0.52	0.10	1.17	1.00	0.12	0.12	1.02
0.64	4.03	0.00	784.1	44.6	53.5								
16.32	6.28	2.06	40.0	0.80	32.0	0.90	0.52	0.10	1.17	1.00	0.12	0.12	1.02
0.63	4.06	0.00	784.4	44.8	53.7								
16.27	6.28	2.06	40.0	0.80	32.0	0.90	0.51	0.10	1.17	1.00	0.12	0.12	1.02
0.63	4.08	0.00	784.7	45.1	54.0								
16.22	6.28	2.05	40.0	0.80	32.0	0.90	0.51	0.10	1.17	1.00	0.12	0.12	1.01
0.63	4.10	0.00	785.0	45.3	54.2								
16.17	6.28	2.04	40.0	0.80	32.0	0.89	0.51	0.10	1.17	1.00	0.12	0.12	1.01
0.63	4.13	0.00	785.4	45.5	54.5								
16.12	6.28	2.04	40.0	0.80	32.0	0.89	0.51	0.10	1.17	1.00	0.12	0.12	1.01
0.63	4.15	0.00	785.7	45.7	54.8								
16.07	6.28	2.03	40.0	0.80	32.0	0.89	0.51	0.10	1.17	1.00	0.12	0.12	1.01
0.63	4.18	0.00	786.0	45.9	55.0								
16.02	6.28	2.03	40.0	0.80	32.0	0.89	0.51	0.10	1.17	1.00	0.12	0.12	1.00
0.62	4.20	0.00	786.3	46.1	55.3								
15.97	6.28	2.02	40.0	0.80	32.0	0.88	0.50	0.10	1.17	1.00	0.12	0.12	1.00
0.62	4.22	0.00	786.6	46.4	55.5								
15.92	6.28	2.01	40.0	0.80	32.0	0.88	0.50	0.10	1.17	1.00	0.12	0.12	1.00
0.62	4.25	0.00	786.9	46.6	55.8								
15.87	6.28	2.01	40.0	0.80	32.0	0.88	0.50	0.10	1.17	1.00	0.12	0.12	1.00
0.62	4.27	0.00	787.2	46.8	56.0								
15.82	6.28	2.00	40.0	0.80	32.0	0.87	0.50	0.10	1.17	1.00	0.12	0.12	0.99
0.62	4.29	0.00	787.5	47.0	56.3								
15.77	6.28	1.99	40.0	0.80	32.0	0.87	0.50	0.10	1.17	1.00	0.12	0.12	0.99
0.62	4.32	0.00	787.8	47.2	56.5								
15.72	6.28	1.99	40.0	0.80	32.0	0.87	0.50	0.10	1.17	1.00	0.12	0.12	0.99
0.61	4.34	0.00	788.2	47.4	56.8								
15.67	6.28	1.98	40.0	0.80	32.0	0.87	0.50	0.10	1.17	1.00	0.12	0.12	0.98
0.61	4.37	0.00	788.5	47.7	57.0								
15.62	6.28	1.97	40.0	0.80	32.0	0.86	0.49	0.10	1.17	1.00	0.12	0.12	0.98
0.61	4.39	0.00	788.8	47.9	57.3								
15.57	6.28	1.97	40.0	0.80	32.0	0.86	0.49	0.10	1.17	1.00	0.12	0.12	0.98
0.61	4.41	0.00	789.1	48.1	57.5								
15.52	6.28	1.96	40.0	0.80	32.0	0.86	0.49	0.10	1.17	1.00	0.12	0.12	0.98
0.61	4.44	0.00	789.4	48.3	57.8								
15.47	6.28	1.95	40.0	0.80	32.0	0.86	0.49	0.10	1.17	1.00	0.12	0.12	0.97
0.61	4.46	0.00	789.7	48.5	58.0								
15.43	6.28	1.95	40.0	0.80	32.0	0.85	0.49	0.10	1.17	1.00	0.12	0.12	0.97
0.60	4.49	0.00	790.0	48.7	58.3								
15.38	6.28	1.94	40.0	0.80	32.0	0.85	0.49	0.10	1.17	1.00	0.12	0.12	0.97
0.60	4.51	0.00	790.3	48.9	58.5								
15.33	6.28	1.94	40.0	0.80	32.0	0.85	0.48	0.10	1.17	1.00	0.12	0.12	0.96
0.60	4.53	0.00	790.6	49.1	58.7								
15.28	6.28	1.93	40.0	0.80	32.0	0.84	0.48	0.10	1.17	1.00	0.12	0.12	0.96
0.60	4.56	0.00	790.9	49.4	59.0								
15.23	6.28	1.92	40.0	0.80	32.0	0.84	0.48	0.10	1.17	1.00	0.12	0.12	0.96
0.60	4.58	0.00	791.2	49.6	59.2								
15.18	6.28	1.92	40.0	0.80	32.0	0.84	0.48	0.10	1.17	1.00	0.12	0.12	0.96
0.60	4.60	0.00	791.5	49.8	59.5								
15.13	6.28	1.91	40.0	0.80	32.0	0.84	0.48	0.10	1.17	1.00	0.12	0.12	0.95
0.59	4.63	0.00	791.8	50.0	59.7								
15.08	6.28	1.90	40.0	0.80	32.0	0.83	0.48	0.10	1.17	1.00	0.12	0.12	0.95
0.59	4.65	0.00	792.1	50.2	59.9								
15.03	6.28	1.90	40.0	0.80	32.0	0.83	0.47	0.10	1.17	1.00	0.12	0.12	0.95
0.59	4.68	0.00	792.4	50.4	60.2								
14.98	6.28	1.89	40.0	0.80	32.0	0.83	0.47	0.10	1.17	1.00	0.12	0.12	0.94
0.59	4.70	0.00	792.7	50.6	60.4								

													0detail
14.93	6.28	1.88	40.0	0.80	32.0	0.82	0.47	0.10	1.17	1.00	0.12	0.12	0.94
0.59	4.72	0.00	793.0	50.8	60.7								
14.88	6.28	1.88	40.0	0.80	32.0	0.82	0.47	0.10	1.17	1.00	0.12	0.12	0.94
0.59	4.75	0.00	793.2	51.0	60.9								
14.83	6.28	1.87	40.0	0.80	32.0	0.82	0.47	0.10	1.17	1.00	0.12	0.12	0.94
0.59	4.77	0.00	793.5	51.2	61.1								
14.78	6.28	1.86	40.0	0.80	32.0	0.82	0.47	0.10	1.17	1.00	0.12	0.12	0.93
0.58	4.80	0.00	793.8	51.4	61.4								
14.73	6.28	1.86	40.0	0.80	32.0	0.81	0.46	0.10	1.17	1.00	0.12	0.12	0.93
0.58	4.82	0.00	794.1	51.6	61.6								
14.68	6.28	1.85	40.0	0.80	32.0	0.81	0.46	0.10	1.17	1.00	0.12	0.12	0.93
0.58	4.84	0.00	794.4	51.8	61.8								
14.63	6.28	1.85	40.0	0.80	32.0	0.81	0.46	0.10	1.17	1.00	0.12	0.12	0.92
0.58	4.87	0.00	794.7	52.1	62.1								
14.58	6.28	1.84	40.0	0.80	32.0	0.80	0.46	0.10	1.17	1.00	0.12	0.12	0.92
0.58	4.89	0.00	795.0	52.3	62.3								
14.53	6.28	1.83	40.0	0.80	32.0	0.80	0.46	0.10	1.17	1.00	0.12	0.12	0.92
0.58	4.91	0.00	795.3	52.5	62.5								
14.48	6.28	1.83	40.0	0.80	32.0	0.80	0.46	0.10	1.17	1.00	0.12	0.12	0.92
0.57	4.94	0.00	795.6	52.7	62.8								
14.43	6.28	1.82	40.0	0.80	32.0	0.80	0.45	0.10	1.17	1.00	0.12	0.12	0.91
0.57	4.96	0.00	795.8	52.9	63.0								
14.38	6.28	1.81	40.0	0.80	32.0	0.79	0.45	0.10	1.17	1.00	0.12	0.12	0.91
0.57	4.99	0.00	796.1	53.1	63.2								
14.33	6.28	1.81	40.0	0.80	32.0	0.79	0.45	0.10	1.17	1.00	0.12	0.12	0.91
0.57	5.01	0.00	796.4	53.3	63.5								
14.28	6.28	1.80	40.0	0.80	32.0	0.79	0.45	0.10	1.17	1.00	0.12	0.12	0.90
0.57	5.03	0.00	796.7	53.5	63.7								
14.23	6.28	1.79	40.0	0.80	32.0	0.78	0.45	0.10	1.17	1.00	0.12	0.12	0.90
0.57	5.06	0.00	797.0	53.7	63.9								
14.19	6.28	1.79	40.0	0.80	32.0	0.78	0.45	0.10	1.17	1.00	0.12	0.12	0.90
0.56	5.08	0.00	797.2	53.9	64.2								
14.14	6.28	1.78	40.0	0.80	32.0	0.78	0.45	0.10	1.17	1.00	0.12	0.12	0.90
0.56	5.11	0.00	797.5	54.1	64.4								
14.09	6.28	1.77	40.0	0.80	32.0	0.78	0.44	0.10	1.17	1.00	0.12	0.12	0.89
0.56	5.13	0.00	797.8	54.3	64.6								
14.04	6.28	1.77	40.0	0.80	32.0	0.77	0.44	0.10	1.17	1.00	0.12	0.12	0.89
0.56	5.15	0.00	798.1	54.5	64.8								
13.99	6.28	1.76	40.0	0.80	32.0	0.77	0.44	0.10	1.17	1.00	0.12	0.12	0.89
0.56	5.18	0.00	798.4	54.7	65.1								
13.94	6.28	1.75	40.0	0.80	32.0	0.77	0.44	0.10	1.17	1.00	0.12	0.12	0.89
0.56	5.20	0.00	798.6	54.9	65.3								
13.89	6.28	1.75	40.0	0.80	32.0	0.76	0.44	0.10	1.17	1.00	0.12	0.12	0.88
0.55	5.22	0.00	798.9	55.1	65.5								
13.84	6.28	1.74	40.0	0.80	32.0	0.76	0.44	0.10	1.17	1.00	0.12	0.12	0.88
0.55	5.25	0.00	799.2	55.3	65.7								
13.79	6.28	1.74	40.0	0.80	32.0	0.76	0.43	0.10	1.17	1.00	0.12	0.12	0.88
0.55	5.27	0.00	799.5	55.4	66.0								
13.74	6.28	1.73	40.0	0.80	32.0	0.76	0.43	0.10	1.17	1.00	0.12	0.12	0.87
0.55	5.30	0.00	799.7	55.6	66.2								
13.69	6.28	1.72	40.0	0.80	32.0	0.75	0.43	0.10	1.17	1.00	0.12	0.12	0.87
0.55	5.32	0.00	800.0	55.8	66.4								
13.64	6.28	1.72	40.0	0.80	32.0	0.75	0.43	0.10	1.17	1.00	0.12	0.12	0.87
0.55	5.34	0.00	800.3	56.0	66.6								
13.59	6.28	1.71	40.0	0.80	32.0	0.75	0.43	0.10	1.17	1.00	0.12	0.12	0.87
0.54	5.37	0.00	800.5	56.2	66.8								
13.54	6.28	1.70	40.0	0.80	32.0	0.75	0.43	0.10	1.17	1.00	0.12	0.12	0.86
0.54	5.39	0.00	800.8	56.4	67.1								
13.49	6.28	1.70	40.0	0.80	32.0	0.74	0.42	0.10	1.17	1.00	0.12	0.12	0.86
0.54	5.42	0.00	801.1	56.6	67.3								
13.44	6.28	1.69	40.0	0.80	32.0	0.74	0.42	0.10	1.17	1.00	0.12	0.12	0.86
0.54	5.44	0.00	801.3	56.8	67.5								
13.39	6.28	1.68	40.0	0.80	32.0	0.74	0.42	0.10	1.17	1.00	0.12	0.12	0.85
0.54	5.46	0.00	801.6	57.0	67.7								
13.34	6.28	1.68	40.0	0.80	32.0	0.73	0.42	0.10	1.17	1.00	0.12	0.12	0.85
0.54	5.49	0.00	801.9	57.2	67.9								
13.29	6.28	1.67	40.0	0.80	32.0	0.73	0.42	0.10	1.17	1.00	0.12	0.12	0.85

Ødetail

0.54	5.51	0.00	802.1	57.4	68.1								
13.24	6.28	1.66	40.0	0.80	32.0	0.73	0.42	0.10	1.17	1.00	0.12	0.12	0.85
0.53	5.53	0.00	802.4	57.6	68.4								
13.19	6.28	1.66	40.0	0.80	32.0	0.73	0.41	0.10	1.17	1.00	0.12	0.12	0.84
0.53	5.56	0.00	802.7	57.8	68.6								
13.14	6.28	1.65	40.0	0.80	32.0	0.72	0.41	0.10	1.17	1.00	0.12	0.12	0.84
0.53	5.58	0.00	802.9	57.9	68.8								
13.09	6.28	1.65	40.0	0.80	32.0	0.72	0.41	0.10	1.17	1.00	0.12	0.12	0.84
0.53	5.61	0.00	803.2	58.1	69.0								
13.04	6.28	1.64	40.0	0.80	32.0	0.72	0.41	0.10	1.17	1.00	0.12	0.12	0.83
0.53	5.63	0.00	803.5	58.3	69.2								
12.99	6.28	1.63	40.0	0.80	32.0	0.71	0.41	0.10	1.17	1.00	0.12	0.12	0.83
0.53	5.65	0.00	803.7	58.5	69.4								
12.95	6.28	1.63	40.0	0.80	32.0	0.71	0.41	0.10	1.17	1.00	0.12	0.12	0.83
0.52	5.68	0.00	804.0	58.7	69.6								
12.90	6.28	1.62	40.0	0.80	32.0	0.71	0.40	0.10	1.17	1.00	0.12	0.12	0.83
0.52	5.70	0.00	804.2	58.9	69.8								
12.85	6.28	1.61	40.0	0.80	32.0	0.71	0.40	0.10	1.17	1.00	0.12	0.12	0.82
0.52	5.73	0.00	804.5	59.1	70.1								
12.80	6.28	1.61	40.0	0.80	32.0	0.70	0.40	0.10	1.17	1.00	0.12	0.12	0.82
0.52	5.75	0.00	804.7	59.3	70.3								
12.75	6.28	1.60	40.0	0.80	32.0	0.70	0.40	0.10	1.17	1.00	0.12	0.12	0.82
0.52	5.77	0.00	805.0	59.4	70.5								
12.70	6.28	1.59	40.0	0.80	32.0	0.70	0.40	0.10	1.17	1.00	0.12	0.12	0.81
0.52	5.80	0.00	805.2	59.6	70.7								
12.65	6.28	1.59	40.0	0.80	32.0	0.69	0.40	0.10	1.17	1.00	0.12	0.12	0.81
0.51	5.82	0.00	805.5	59.8	70.9								
12.60	6.28	1.58	40.0	0.80	32.0	0.69	0.40	0.10	1.17	1.00	0.12	0.12	0.81
0.51	5.85	0.00	805.8	60.0	71.1								
12.55	6.28	1.57	40.0	0.80	32.0	0.69	0.39	0.10	1.17	1.00	0.12	0.12	0.81
0.51	5.87	0.00	806.0	60.2	71.3								
12.50	6.28	1.57	40.0	0.80	32.0	0.69	0.39	0.10	1.17	1.00	0.12	0.12	0.80
0.51	5.89	0.00	806.3	60.4	71.5								
12.45	6.28	1.56	40.0	0.80	32.0	0.68	0.39	0.10	1.17	1.00	0.12	0.12	0.80
0.51	5.92	0.00	806.5	60.5	71.7								
12.40	6.28	1.55	40.0	0.80	32.0	0.68	0.39	0.10	1.17	1.00	0.12	0.12	0.80
0.51	5.94	0.00	806.8	60.7	71.9								
12.35	6.28	1.55	40.0	0.80	32.0	0.68	0.39	0.10	1.17	1.00	0.12	0.12	0.79
0.50	5.96	0.00	807.0	60.9	72.1								
12.30	6.28	1.54	40.0	0.80	32.0	0.67	0.39	0.10	1.17	1.00	0.12	0.12	0.79
0.50	5.99	0.00	807.2	61.1	72.3								
12.25	6.28	1.54	40.0	0.80	32.0	0.67	0.38	0.10	1.17	1.00	0.12	0.12	0.79
0.50	6.01	0.00	807.5	61.3	72.5								
12.20	6.28	1.53	40.0	0.80	32.0	0.67	0.38	0.10	1.17	1.00	0.12	0.12	0.79
0.50	6.04	0.00	807.7	61.4	72.7								
12.15	6.28	1.52	40.0	0.80	32.0	0.67	0.38	0.10	1.17	1.00	0.12	0.12	0.78
0.50	6.06	0.00	808.0	61.6	72.9								
12.10	6.28	1.52	40.0	0.80	32.0	0.66	0.38	0.10	1.17	1.00	0.12	0.12	0.78
0.50	6.08	0.00	808.2	61.8	73.1								
12.05	6.28	1.51	40.0	0.80	32.0	0.66	0.38	0.10	1.17	1.00	0.12	0.12	0.78
0.49	6.11	0.00	808.5	62.0	73.3								
12.00	6.28	1.50	40.0	0.80	32.0	0.66	0.38	0.10	1.17	1.00	0.12	0.12	0.78
0.49	6.13	0.00	808.7	62.2	73.5								
11.95	6.28	1.50	40.0	0.80	32.0	0.65	0.37	0.10	1.17	1.00	0.12	0.12	0.77
0.49	6.16	0.00	808.9	62.3	73.7								
11.90	6.28	1.49	40.0	0.80	32.0	0.65	0.37	0.10	1.17	1.00	0.12	0.12	0.77
0.49	6.18	0.00	809.2	62.5	73.9								
11.85	6.28	1.48	40.0	0.80	32.0	0.65	0.37	0.10	1.17	1.00	0.12	0.12	0.77
0.49	6.20	0.00	809.4	62.7	74.1								
11.80	6.28	1.48	40.0	0.80	32.0	0.65	0.37	0.10	1.17	1.00	0.12	0.12	0.76
0.49	6.23	0.00	809.7	62.9	74.3								
11.76	6.28	1.47	40.0	0.80	32.0	0.64	0.37	0.10	1.17	1.00	0.12	0.12	0.76
0.49	6.25	0.00	809.9	63.0	74.5								
11.71	6.28	1.46	40.0	0.80	32.0	0.64	0.37	0.10	1.17	1.00	0.12	0.12	0.76
0.48	6.27	0.00	810.1	63.2	74.7								
11.66	6.28	1.46	40.0	0.80	32.0	0.64	0.36	0.10	1.17	1.00	0.12	0.12	0.76
0.48	6.30	0.00	810.4	63.4	74.9								

													0detail
11.61	6.28	1.45	40.0	0.80	32.0	0.64	0.36	0.10	1.17	1.00	0.12	0.12	0.75
0.48	6.32	0.00	810.6	63.6	75.1								
11.56	6.28	1.45	40.0	0.80	32.0	0.63	0.36	0.10	1.17	1.00	0.12	0.12	0.75
0.48	6.35	0.00	810.8	63.7	75.3								
11.51	6.28	1.44	40.0	0.80	32.0	0.63	0.36	0.10	1.17	1.00	0.12	0.12	0.75
0.48	6.37	0.00	811.1	63.9	75.4								
11.46	6.28	1.43	40.0	0.80	32.0	0.63	0.36	0.10	1.17	1.00	0.12	0.12	0.74
0.48	6.39	0.00	811.3	64.1	75.6								
11.41	6.28	1.43	40.0	0.80	32.0	0.62	0.36	0.10	1.17	1.00	0.12	0.12	0.74
0.47	6.42	0.00	811.5	64.2	75.8								
11.36	6.28	1.42	40.0	0.80	32.0	0.62	0.35	0.10	1.17	1.00	0.12	0.12	0.74
0.47	6.44	0.00	811.8	64.4	76.0								
11.31	6.28	1.41	40.0	0.80	32.0	0.62	0.35	0.10	1.17	1.00	0.12	0.12	0.74
0.47	6.47	0.00	812.0	64.6	76.2								
11.26	6.28	1.41	40.0	0.80	32.0	0.62	0.35	0.10	1.17	1.00	0.12	0.12	0.73
0.47	6.49	0.00	812.2	64.8	76.4								
11.21	6.28	1.40	40.0	0.80	32.0	0.61	0.35	0.10	1.17	1.00	0.12	0.12	0.73
0.47	6.51	0.00	812.5	64.9	76.6								
11.16	6.28	1.39	40.0	0.80	32.0	0.61	0.35	0.10	1.17	1.00	0.12	0.12	0.73
0.47	6.54	0.00	812.7	65.1	76.8								
11.11	6.28	1.39	40.0	0.80	32.0	0.61	0.35	0.10	1.17	1.00	0.12	0.12	0.72
0.46	6.56	0.00	812.9	65.3	76.9								
11.06	6.28	1.38	40.0	0.80	32.0	0.60	0.35	0.10	1.17	1.00	0.12	0.12	0.72
0.46	6.58	0.00	813.1	65.4	77.1								
11.01	6.28	1.37	40.0	0.80	32.0	0.60	0.34	0.10	1.17	1.00	0.12	0.12	0.72
0.46	6.61	0.00	813.4	65.6	77.3								
10.96	6.28	1.37	40.0	0.80	32.0	0.60	0.34	0.10	1.17	1.00	0.12	0.12	0.72
0.46	6.63	0.00	813.6	65.8	77.5								
10.91	6.28	1.36	40.0	0.80	32.0	0.60	0.34	0.10	1.17	1.00	0.12	0.12	0.71
0.46	6.66	0.00	813.8	65.9	77.7								
10.86	6.28	1.36	40.0	0.80	32.0	0.59	0.34	0.10	1.17	1.00	0.12	0.12	0.71
0.46	6.68	0.00	814.0	66.1	77.9								
10.81	6.28	1.35	40.0	0.80	32.0	0.59	0.34	0.10	1.17	1.00	0.12	0.12	0.71
0.45	6.70	0.00	814.2	66.3	78.0								
10.76	6.28	1.34	40.0	0.80	32.0	0.59	0.34	0.10	1.17	1.00	0.12	0.12	0.70
0.45	6.73	0.00	814.5	66.4	78.2								
10.71	6.28	1.34	40.0	0.80	32.0	0.58	0.33	0.10	1.17	1.00	0.12	0.12	0.70
0.45	6.75	0.00	814.7	66.6	78.4								
10.66	6.28	1.33	40.0	0.80	32.0	0.58	0.33	0.10	1.17	1.00	0.12	0.12	0.70
0.45	6.78	0.00	814.9	66.8	78.6								
10.61	6.28	1.32	40.0	0.80	32.0	0.58	0.33	0.10	1.17	1.00	0.12	0.12	0.70
0.45	6.80	0.00	815.1	66.9	78.8								
10.56	6.28	1.32	40.0	0.80	32.0	0.58	0.33	0.10	1.17	1.00	0.12	0.12	0.69
0.45	6.82	0.00	815.3	67.1	78.9								
10.52	6.28	1.31	40.0	0.80	32.0	0.57	0.33	0.10	1.17	1.00	0.12	0.12	0.69
0.44	6.85	0.00	815.5	67.2	79.1								
10.47	6.28	1.30	40.0	0.80	32.0	0.57	0.33	0.10	1.17	1.00	0.12	0.12	0.69
0.44	6.87	0.00	815.8	67.4	79.3								
10.42	6.28	1.30	40.0	0.80	32.0	0.57	0.32	0.10	1.17	1.00	0.12	0.12	0.68
0.44	6.89	0.00	816.0	67.6	79.5								
10.37	6.28	1.29	40.0	0.80	32.0	0.56	0.32	0.10	1.17	1.00	0.12	0.12	0.68
0.44	6.92	0.00	816.2	67.7	79.6								
10.32	6.28	1.28	40.0	0.80	32.0	0.56	0.32	0.10	1.17	1.00	0.12	0.12	0.68
0.44	6.94	0.00	816.4	67.9	79.8								
10.27	6.28	1.28	40.0	0.80	32.0	0.56	0.32	0.10	1.17	1.00	0.12	0.12	0.68
0.44	6.97	0.00	816.6	68.1	80.0								
10.22	6.28	1.27	40.0	0.80	32.0	0.56	0.32	0.10	1.17	1.00	0.12	0.12	0.67
0.44	6.99	0.00	816.8	68.2	80.2								
10.17	6.28	1.26	40.0	0.80	32.0	0.55	0.32	0.10	1.17	1.00	0.12	0.12	0.67
0.43	7.01	0.00	817.0	68.4	80.3								
10.12	6.28	1.26	40.0	0.80	32.0	0.55	0.31	0.10	1.17	1.00	0.12	0.12	0.67
0.43	7.04	0.00	817.2	68.5	80.5								
10.07	6.28	1.25	40.0	0.80	32.0	0.55	0.31	0.10	1.17	1.00	0.12	0.12	0.67
0.43	7.06	0.00	817.4	68.7	80.7								
10.02	6.28	1.25	40.0	0.80	32.0	0.54	0.31	0.10	1.17	1.00	0.12	0.12	0.66
0.43	7.09	0.00	817.6	68.8	80.8								
9.97	6.28	1.24	40.0	0.80	32.0	0.54	0.31	0.10	1.17	1.00	0.12	0.12	0.66

Ødetail													
0.43	7.11	0.00	817.9	69.0	81.0								
9.92	6.28	1.23	40.0	0.80	32.0	0.54	0.31	0.10	1.17	1.00	0.12	0.12	0.66
0.43	7.13	0.00	818.1	69.2	81.2								
9.87	6.28	1.23	40.0	0.80	32.0	0.54	0.31	0.10	1.17	1.00	0.12	0.12	0.65
0.42	7.16	0.00	818.3	69.3	81.4								
9.82	6.28	1.22	40.0	0.80	32.0	0.53	0.30	0.10	1.17	1.00	0.12	0.12	0.65
0.42	7.18	0.00	818.5	69.5	81.5								
9.77	6.28	1.21	40.0	0.80	32.0	0.53	0.30	0.10	1.17	1.00	0.12	0.12	0.65
0.42	7.20	0.00	818.7	69.6	81.7								
9.72	6.28	1.21	40.0	0.80	32.0	0.53	0.30	0.10	1.17	1.00	0.12	0.12	0.65
0.42	7.23	0.00	818.9	69.8	81.9								
9.67	6.28	1.20	40.0	0.80	32.0	0.53	0.30	0.10	1.17	1.00	0.12	0.12	0.64
0.42	7.25	0.00	819.1	69.9	82.0								
9.62	6.28	1.19	40.0	0.80	32.0	0.52	0.30	0.10	1.17	1.00	0.12	0.12	0.64
0.42	7.28	0.00	819.3	70.1	82.2								
9.57	6.28	1.19	40.0	0.80	32.0	0.52	0.30	0.10	1.17	1.00	0.12	0.12	0.64
0.41	7.30	0.00	819.5	70.2	82.3								
9.52	6.28	1.18	40.0	0.80	32.0	0.52	0.30	0.10	1.17	1.00	0.12	0.12	0.63
0.41	7.32	0.00	819.7	70.4	82.5								
9.47	6.28	1.17	40.0	0.80	32.0	0.51	0.29	0.10	1.17	1.00	0.12	0.12	0.63
0.41	7.35	0.00	819.9	70.5	82.7								
9.42	6.28	1.17	40.0	0.80	32.0	0.51	0.29	0.10	1.17	1.00	0.12	0.12	0.63
0.41	7.37	0.00	820.1	70.7	82.8								
9.37	6.28	1.16	40.0	0.80	32.0	0.51	0.29	0.10	1.17	1.00	0.12	0.12	0.63
0.41	7.40	0.00	820.3	70.8	83.0								
9.32	6.28	1.16	40.0	0.80	32.0	0.51	0.29	0.10	1.17	1.00	0.12	0.12	0.62
0.41	7.42	0.00	820.4	71.0	83.2								
9.28	6.28	1.15	40.0	0.80	32.0	0.50	0.29	0.10	1.17	1.00	0.12	0.12	0.62
0.40	7.44	0.00	820.6	71.1	83.3								
9.23	6.28	1.14	40.0	0.80	32.0	0.50	0.29	0.10	1.17	1.00	0.12	0.12	0.62
0.40	7.47	0.00	820.8	71.3	83.5								
9.18	6.28	1.14	40.0	0.80	32.0	0.50	0.28	0.10	1.17	1.00	0.12	0.12	0.61
0.40	7.49	0.00	821.0	71.4	83.6								
9.13	6.28	1.13	40.0	0.80	32.0	0.49	0.28	0.10	1.17	1.00	0.12	0.12	0.61
0.40	7.52	0.00	821.2	71.6	83.8								
9.08	6.28	1.12	40.0	0.80	32.0	0.49	0.28	0.10	1.17	1.00	0.12	0.12	0.61
0.40	7.54	0.00	821.4	71.7	83.9								
9.03	6.28	1.12	40.0	0.80	32.0	0.49	0.28	0.10	1.17	1.00	0.12	0.12	0.61
0.40	7.56	0.00	821.6	71.9	84.1								
8.98	6.28	1.11	40.0	0.80	32.0	0.49	0.28	0.10	1.17	1.00	0.12	0.12	0.60
0.39	7.59	0.00	821.8	72.0	84.3								
8.93	6.28	1.10	40.0	0.80	32.0	0.48	0.28	0.10	1.17	1.00	0.12	0.12	0.60
0.39	7.61	0.00	822.0	72.2	84.4								
8.88	6.28	1.10	40.0	0.80	32.0	0.48	0.27	0.10	1.17	1.00	0.12	0.12	0.60
0.39	7.63	0.00	822.2	72.3	84.6								
8.83	6.28	1.09	40.0	0.80	32.0	0.48	0.27	0.10	1.17	1.00	0.12	0.12	0.59
0.39	7.66	0.00	822.3	72.5	84.7								
8.78	6.28	1.08	40.0	0.80	32.0	0.47	0.27	0.10	1.17	1.00	0.12	0.12	0.59
0.39	7.68	0.00	822.5	72.6	84.9								
8.73	6.28	1.08	40.0	0.80	32.0	0.47	0.27	0.10	1.17	1.00	0.12	0.12	0.59
0.39	7.71	0.00	822.7	72.8	85.0								
8.68	6.28	1.07	40.0	0.80	32.0	0.47	0.27	0.10	1.17	1.00	0.12	0.12	0.59
0.39	7.73	0.00	822.9	72.9	85.2								
8.63	6.28	1.06	40.0	0.80	32.0	0.47	0.27	0.10	1.17	1.00	0.12	0.12	0.58
0.38	7.75	0.00	823.1	73.1	85.3								
8.58	6.28	1.06	40.0	0.80	32.0	0.46	0.26	0.10	1.17	1.00	0.12	0.12	0.58
0.38	7.78	0.00	823.3	73.2	85.5								
8.53	6.28	1.05	40.0	0.80	32.0	0.46	0.26	0.10	1.17	1.00	0.12	0.12	0.58
0.38	7.80	0.00	823.4	73.3	85.6								
8.48	6.28	1.05	40.0	0.80	32.0	0.46	0.26	0.10	1.17	1.00	0.12	0.12	0.57
0.38	7.83	0.00	823.6	73.5	85.8								
8.43	6.28	1.04	40.0	0.80	32.0	0.45	0.26	0.10	1.17	1.00	0.12	0.12	0.57
0.38	7.85	0.00	823.8	73.6	85.9								
8.38	6.28	1.03	40.0	0.80	32.0	0.45	0.26	0.10	1.17	1.00	0.12	0.12	0.57
0.38	7.87	0.00	824.0	73.8	86.1								
8.33	6.28	1.03	40.0	0.80	32.0	0.45	0.26	0.10	1.17	1.00	0.12	0.12	0.57
0.37	7.90	0.00	824.1	73.9	86.2								

													0detail
8.28	6.28	1.02	40.0	0.80	32.0	0.45	0.25	0.10	1.17	1.00	0.12	0.12	0.56
0.37	7.92	0.00	824.3	74.0	86.4								
8.23	6.28	1.01	40.0	0.80	32.0	0.44	0.25	0.10	1.17	1.00	0.12	0.12	0.56
0.37	7.94	0.00	824.5	74.2	86.5								
8.18	6.28	1.01	40.0	0.80	32.0	0.44	0.25	0.10	1.17	1.00	0.12	0.12	0.56
0.37	7.97	0.00	824.7	74.3	86.7								
8.13	6.28	1.00	40.0	0.80	32.0	0.44	0.25	0.10	1.17	1.00	0.12	0.12	0.56
0.37	7.99	0.00	824.8	74.5	86.8								
8.08	6.28	0.99	40.0	0.80	32.0	0.43	0.25	0.10	1.17	1.00	0.12	0.12	0.55
0.37	8.02	0.00	825.0	74.6	86.9								
8.04	6.28	0.99	40.0	0.80	32.0	0.43	0.25	0.10	1.17	1.00	0.12	0.12	0.55
0.36	8.04	0.00	825.2	74.7	87.1								
7.99	6.28	0.98	40.0	0.80	32.0	0.43	0.25	0.10	1.17	1.00	0.12	0.12	0.55
0.36	8.06	0.00	825.4	74.9	87.2								
7.94	6.28	0.97	40.0	0.80	32.0	0.43	0.24	0.10	1.17	1.00	0.12	0.12	0.54
0.36	8.09	0.00	825.5	75.0	87.4								
7.89	6.28	0.97	40.0	0.80	32.0	0.42	0.24	0.10	1.17	1.00	0.12	0.12	0.54
0.36	8.11	0.00	825.7	75.1	87.5								
7.84	6.28	0.96	40.0	0.80	32.0	0.42	0.24	0.10	1.17	1.00	0.12	0.12	0.54
0.36	8.14	0.00	825.9	75.3	87.6								
7.79	6.28	0.96	40.0	0.80	32.0	0.42	0.24	0.10	1.17	1.00	0.12	0.12	0.54
0.36	8.16	0.00	826.0	75.4	87.8								
7.74	6.28	0.95	40.0	0.80	32.0	0.42	0.24	0.10	1.17	1.00	0.12	0.12	0.53
0.35	8.18	0.00	826.2	75.5	87.9								
7.69	6.28	0.94	40.0	0.80	32.0	0.41	0.24	0.10	1.17	1.00	0.12	0.12	0.53
0.35	8.21	0.00	826.4	75.7	88.1								
7.64	6.28	0.94	40.0	0.80	32.0	0.41	0.23	0.10	1.17	1.00	0.12	0.12	0.53
0.35	8.23	0.00	826.5	75.8	88.2								
7.59	6.28	0.93	40.0	0.80	32.0	0.41	0.23	0.10	1.17	1.00	0.12	0.12	0.52
0.35	8.25	0.00	826.7	75.9	88.3								
7.54	6.28	0.92	40.0	0.80	32.0	0.40	0.23	0.10	1.17	1.00	0.12	0.12	0.52
0.35	8.28	0.00	826.8	76.1	88.5								
7.49	6.28	0.92	40.0	0.80	32.0	0.40	0.23	0.10	1.17	1.00	0.12	0.12	0.52
0.35	8.30	0.00	827.0	76.2	88.6								
7.44	6.28	0.91	40.0	0.80	32.0	0.40	0.23	0.10	1.17	1.00	0.12	0.12	0.52
0.34	8.33	0.00	827.2	76.3	88.7								
7.39	6.28	0.90	40.0	0.80	32.0	0.40	0.23	0.10	1.17	1.00	0.12	0.12	0.51
0.34	8.35	0.00	827.3	76.5	88.9								
7.34	6.28	0.90	40.0	0.80	32.0	0.39	0.22	0.10	1.17	1.00	0.12	0.12	0.51
0.34	8.37	0.00	827.5	76.6	89.0								
7.29	6.28	0.89	40.0	0.80	32.0	0.39	0.22	0.10	1.17	1.00	0.12	0.12	0.51
0.34	8.40	0.00	827.6	76.7	89.1								
7.24	6.28	0.88	40.0	0.80	32.0	0.39	0.22	0.10	1.17	1.00	0.12	0.12	0.50
0.34	8.42	0.00	827.8	76.9	89.3								
7.19	6.28	0.88	40.0	0.80	32.0	0.38	0.22	0.10	1.17	1.00	0.12	0.12	0.50
0.34	8.45	0.00	828.0	77.0	89.4								
7.14	6.28	0.87	40.0	0.80	32.0	0.38	0.22	0.10	1.17	1.00	0.12	0.12	0.50
0.34	8.47	0.00	828.1	77.1	89.5								
7.09	6.28	0.87	40.0	0.80	32.0	0.38	0.22	0.10	1.17	1.00	0.12	0.12	0.50
0.33	8.49	0.00	828.3	77.2	89.7								
7.04	6.28	0.86	40.0	0.80	32.0	0.38	0.21	0.10	1.17	1.00	0.12	0.12	0.49
0.33	8.52	0.00	828.4	77.4	89.8								
6.99	6.28	0.85	40.0	0.80	32.0	0.37	0.21	0.10	1.17	1.00	0.12	0.12	0.49
0.33	8.54	0.00	828.6	77.5	89.9								
6.94	6.28	0.85	40.0	0.80	32.0	0.37	0.21	0.10	1.17	1.00	0.12	0.12	0.49
0.33	8.56	0.00	828.7	77.6	90.0								
6.89	6.28	0.84	40.0	0.80	32.0	0.37	0.21	0.10	1.17	1.00	0.12	0.12	0.48
0.33	8.59	0.00	828.9	77.8	90.2								
6.84	6.28	0.83	40.0	0.80	32.0	0.36	0.21	0.10	1.17	1.00	0.12	0.12	0.48
0.33	8.61	0.00	829.0	77.9	90.3								
6.80	6.28	0.83	40.0	0.80	32.0	0.36	0.21	0.10	1.17	1.00	0.12	0.12	0.48
0.32	8.64	0.00	829.2	78.0	90.4								
6.75	6.28	0.82	40.0	0.80	32.0	0.36	0.20	0.10	1.17	1.00	0.12	0.12	0.48
0.32	8.66	0.00	829.3	78.1	90.5								
6.70	6.28	0.81	40.0	0.80	32.0	0.36	0.20	0.10	1.17	1.00	0.12	0.12	0.47
0.32	8.68	0.00	829.5	78.3	90.7								
6.65	6.28	0.81	40.0	0.80	32.0	0.35	0.20	0.10	1.17	1.00	0.12	0.12	0.47

Ødetail													
0.32	8.71	0.00	829.6	78.4	90.8								
6.60	6.28	0.80	40.0	0.80	32.0	0.35	0.20	0.10	1.17	1.00	0.12	0.12	0.47
0.32	8.73	0.00	829.8	78.5	90.9								
6.55	6.28	0.79	40.0	0.80	32.0	0.35	0.20	0.10	1.17	1.00	0.12	0.12	0.46
0.32	8.76	0.00	829.9	78.6	91.0								
6.50	6.28	0.79	40.0	0.80	32.0	0.34	0.20	0.10	1.17	1.00	0.12	0.12	0.46
0.31	8.78	0.00	830.1	78.7	91.2								
6.45	6.28	0.78	40.0	0.80	32.0	0.34	0.20	0.10	1.17	1.00	0.12	0.12	0.46
0.31	8.80	0.00	830.2	78.9	91.3								
6.40	6.28	0.77	40.0	0.80	32.0	0.34	0.19	0.10	1.17	1.00	0.12	0.12	0.46
0.31	8.83	0.00	830.3	79.0	91.4								
6.35	6.28	0.77	40.0	0.80	32.0	0.34	0.19	0.10	1.17	1.00	0.12	0.12	0.45
0.31	8.85	0.00	830.5	79.1	91.5								
6.30	6.28	0.76	40.0	0.80	32.0	0.33	0.19	0.10	1.17	1.00	0.12	0.12	0.45
0.31	8.87	0.00	830.6	79.2	91.6								
6.25	6.28	0.76	40.0	0.80	32.0	0.33	0.19	0.10	1.17	1.00	0.12	0.12	0.45
0.31	8.90	0.00	830.8	79.3	91.7								
6.20	6.28	0.75	40.0	0.80	32.0	0.33	0.19	0.10	1.17	1.00	0.12	0.12	0.45
0.30	8.92	0.00	830.9	79.5	91.9								
6.15	6.28	0.74	40.0	0.80	32.0	0.32	0.19	0.10	1.17	1.00	0.12	0.12	0.44
0.30	8.95	0.00	831.0	79.6	92.0								
6.10	6.28	0.74	40.0	0.80	32.0	0.32	0.18	0.10	1.17	1.00	0.12	0.12	0.44
0.30	8.97	0.00	831.2	79.7	92.1								
6.05	6.28	0.73	40.0	0.80	32.0	0.32	0.18	0.10	1.17	1.00	0.12	0.12	0.44
0.30	8.99	0.00	831.3	79.8	92.2								
6.00	6.28	0.72	40.0	0.80	32.0	0.32	0.18	0.10	1.17	1.00	0.12	0.12	0.43
0.30	9.02	0.00	831.4	79.9	92.3								
5.95	6.28	0.72	30.0	0.80	24.0	0.22	0.13	0.10	1.17	1.00	0.12	0.12	0.34
0.25	9.04	0.00	831.6	80.0	92.4								
5.90	6.28	0.71	30.0	0.80	24.0	0.22	0.13	0.10	1.17	1.00	0.12	0.12	0.34
0.24	9.07	0.00	831.7	80.1	92.5								
5.85	6.28	0.71	30.0	0.80	24.0	0.22	0.13	0.10	1.17	1.00	0.12	0.12	0.34
0.24	9.09	0.00	831.8	80.2	92.6								
5.80	6.28	0.70	30.0	0.80	24.0	0.22	0.12	0.10	1.17	1.00	0.12	0.12	0.34
0.24	9.11	0.00	831.9	80.3	92.7								
5.75	6.28	0.69	30.0	0.80	24.0	0.22	0.12	0.10	1.17	1.00	0.12	0.12	0.33
0.24	9.14	0.00	832.0	80.4	92.8								
5.70	6.28	0.69	30.0	0.80	24.0	0.21	0.12	0.10	1.17	1.00	0.12	0.12	0.33
0.24	9.16	0.00	832.1	80.5	92.9								
5.65	6.28	0.68	30.0	0.80	24.0	0.21	0.12	0.10	1.17	1.00	0.12	0.12	0.33
0.24	9.18	0.00	832.2	80.6	93.0								
5.60	6.28	0.68	30.0	0.80	24.0	0.21	0.12	0.10	1.17	1.00	0.12	0.12	0.33
0.24	9.21	0.00	832.3	80.7	93.0								
5.56	6.28	0.67	30.0	0.80	24.0	0.21	0.12	0.10	1.17	1.00	0.12	0.12	0.33
0.24	9.23	0.00	832.4	80.8	93.1								
5.51	6.28	0.66	30.0	0.80	24.0	0.21	0.12	0.10	1.17	1.00	0.12	0.12	0.32
0.24	9.26	0.00	832.5	80.9	93.2								
5.46	6.28	0.66	30.0	0.80	24.0	0.20	0.12	0.10	1.17	1.00	0.12	0.12	0.32
0.23	9.28	0.00	832.6	81.0	93.3								
5.41	6.28	0.65	30.0	0.80	24.0	0.20	0.12	0.10	1.17	1.00	0.12	0.12	0.32
0.23	9.30	0.00	832.7	81.1	93.4								
5.36	6.28	0.65	30.0	0.80	24.0	0.20	0.12	0.10	1.17	1.00	0.12	0.12	0.32
0.23	9.33	0.00	832.8	81.2	93.5								
5.31	6.28	0.64	30.0	0.80	24.0	0.20	0.11	0.10	1.17	1.00	0.12	0.12	0.32
0.23	9.35	0.00	832.9	81.3	93.6								
5.26	6.28	0.63	30.0	0.80	24.0	0.20	0.11	0.10	1.17	1.00	0.12	0.12	0.32
0.23	9.38	0.00	833.0	81.4	93.6								
5.21	6.28	0.63	30.0	0.80	24.0	0.20	0.11	0.10	1.17	1.00	0.12	0.12	0.31
0.23	9.40	0.00	833.1	81.5	93.7								
5.16	6.28	0.62	30.0	0.80	24.0	0.19	0.11	0.10	1.17	1.00	0.12	0.12	0.31
0.23	9.42	0.00	833.2	81.6	93.8								
5.11	6.28	0.62	30.0	0.80	24.0	0.19	0.11	0.10	1.17	1.00	0.12	0.12	0.31
0.23	9.45	0.00	833.3	81.7	93.9								
5.06	6.28	0.61	30.0	0.80	24.0	0.19	0.11	0.10	1.17	1.00	0.12	0.12	0.31
0.23	9.47	0.00	833.4	81.8	94.0								
5.01	6.28	0.60	30.0	0.80	24.0	0.19	0.11	0.10	1.17	1.00	0.12	0.12	0.31
0.23	9.50	0.00	833.5	81.9	94.1								

													0detail
4.96	6.28	0.60	30.0	0.80	24.0	0.19	0.11	0.10	1.17	1.00	0.12	0.12	0.30
0.22	9.52	0.00	833.6	82.0	94.1								
4.91	6.28	0.59	30.0	0.80	24.0	0.18	0.11	0.10	1.17	1.00	0.12	0.12	0.30
0.22	9.54	0.00	833.7	82.1	94.2								
4.86	6.28	0.59	30.0	0.80	24.0	0.18	0.10	0.10	1.17	1.00	0.12	0.12	0.30
0.22	9.57	0.00	833.7	82.2	94.3								
4.81	6.28	0.58	30.0	0.80	24.0	0.18	0.10	0.10	1.17	1.00	0.12	0.12	0.30
0.22	9.59	0.00	833.8	82.2	94.4								
4.76	6.28	0.57	30.0	0.80	24.0	0.18	0.10	0.10	1.17	1.00	0.12	0.12	0.30
0.22	9.61	0.00	833.9	82.3	94.5								
4.71	6.28	0.57	30.0	0.80	24.0	0.18	0.10	0.10	1.17	1.00	0.12	0.12	0.29
0.22	9.64	0.00	834.0	82.4	94.6								
4.66	6.28	0.56	30.0	0.80	24.0	0.18	0.10	0.10	1.17	1.00	0.12	0.12	0.29
0.22	9.66	0.00	834.1	82.5	94.6								
4.61	6.28	0.56	30.0	0.80	24.0	0.17	0.10	0.10	1.17	1.00	0.12	0.12	0.29
0.22	9.69	0.00	834.2	82.6	94.7								
4.56	6.28	0.55	30.0	0.80	24.0	0.17	0.10	0.10	1.17	1.00	0.12	0.12	0.29
0.22	9.71	0.00	834.3	82.7	94.8								
4.51	6.28	0.54	30.0	0.80	24.0	0.17	0.10	0.10	1.17	1.00	0.12	0.12	0.29
0.21	9.73	0.00	834.4	82.8	94.9								
4.46	6.28	0.54	30.0	0.80	24.0	0.17	0.10	0.10	1.17	1.00	0.12	0.12	0.29
0.21	9.76	0.00	834.5	82.9	94.9								
4.41	6.28	0.53	30.0	0.80	24.0	0.17	0.09	0.10	1.17	1.00	0.12	0.12	0.28
0.21	9.78	0.00	834.6	83.0	95.0								
4.36	6.28	0.53	30.0	0.80	24.0	0.16	0.09	0.10	1.17	1.00	0.12	0.12	0.28
0.21	9.81	0.00	834.6	83.1	95.1								
4.32	6.28	0.52	30.0	0.80	24.0	0.16	0.09	0.10	1.17	1.00	0.12	0.12	0.28
0.21	9.83	0.00	834.7	83.2	95.2								
4.27	6.28	0.51	30.0	0.80	24.0	0.16	0.09	0.10	1.17	1.00	0.12	0.12	0.28
0.21	9.85	0.00	834.8	83.2	95.3								
4.22	6.28	0.51	30.0	0.80	24.0	0.16	0.09	0.10	1.17	1.00	0.12	0.12	0.28
0.21	9.88	0.00	834.9	83.3	95.3								
4.17	6.28	0.50	30.0	0.80	24.0	0.16	0.09	0.10	1.17	1.00	0.12	0.12	0.27
0.21	9.90	0.00	835.0	83.4	95.4								
4.12	6.28	0.50	30.0	0.80	24.0	0.15	0.09	0.10	1.17	1.00	0.12	0.12	0.27
0.21	9.92	0.00	835.1	83.5	95.5								
4.07	6.28	0.49	30.0	0.80	24.0	0.15	0.09	0.10	1.17	1.00	0.12	0.12	0.27
0.20	9.95	0.00	835.2	83.6	95.5								
4.02	6.28	0.49	30.0	0.80	24.0	0.15	0.09	0.10	1.17	1.00	0.12	0.12	0.27
0.20	9.97	0.00	835.2	83.7	95.6								
3.97	6.28	0.48	30.0	0.80	24.0	0.15	0.09	0.10	1.17	1.00	0.12	0.12	0.27
0.20	10.00	0.00	835.3	83.8	95.7								
3.92	6.28	0.47	30.0	0.80	24.0	0.15	0.08	0.10	1.17	1.00	0.12	0.12	0.26
0.20	10.02	0.00	835.4	83.9	95.8								
3.87	6.28	0.47	30.0	0.80	24.0	0.15	0.08	0.10	1.17	1.00	0.12	0.12	0.26
0.20	10.04	0.00	835.5	83.9	95.8								
3.82	6.28	0.46	30.0	0.80	24.0	0.14	0.08	0.10	1.17	1.00	0.12	0.12	0.26
0.20	10.07	0.00	835.6	84.0	95.9								
3.77	6.28	0.46	30.0	0.80	24.0	0.14	0.08	0.10	1.17	1.00	0.12	0.12	0.26
0.20	10.09	0.00	835.7	84.1	96.0								
3.72	6.28	0.45	30.0	0.80	24.0	0.14	0.08	0.10	1.17	1.00	0.12	0.12	0.26
0.20	10.12	0.00	835.7	84.2	96.1								
3.67	6.28	0.44	30.0	0.80	24.0	0.14	0.08	0.10	1.17	1.00	0.12	0.12	0.26
0.20	10.14	0.00	835.8	84.3	96.1								
3.62	6.28	0.44	30.0	0.80	24.0	0.14	0.08	0.10	1.17	1.00	0.12	0.12	0.25
0.20	10.16	0.00	835.9	84.4	96.2								
3.57	6.28	0.43	30.0	0.80	24.0	0.13	0.08	0.10	1.17	1.00	0.12	0.12	0.25
0.19	10.19	0.00	836.0	84.5	96.3								
3.52	6.28	0.43	30.0	0.80	24.0	0.13	0.08	0.10	1.17	1.00	0.12	0.12	0.25
0.19	10.21	0.00	836.1	84.5	96.3								
3.47	6.28	0.42	30.0	0.80	24.0	0.13	0.07	0.10	1.17	1.00	0.12	0.12	0.25
0.19	10.23	0.00	836.1	84.6	96.4								
3.42	6.28	0.41	30.0	0.80	24.0	0.13	0.07	0.10	1.17	1.00	0.12	0.12	0.25
0.19	10.26	0.00	836.2	84.7	96.5								
3.37	6.28	0.41	30.0	0.80	24.0	0.13	0.07	0.10	1.17	1.00	0.12	0.12	0.24
0.19	10.28	0.00	836.3	84.8	96.5								
3.32	6.28	0.40	30.0	0.80	24.0	0.13	0.07	0.10	1.17	1.00	0.12	0.12	0.24

Ødetail

0.12 12.02 0.00 840.0 89.7 100.0

SETTLEMENT based on Ultimate Loading by Vesic Method (1977):

Ztip=24.75 Btip= 2.00 Cp= 0.135 Cs= 0.202
Xpp=2.545-in Xps= 0.052-in Xtip= 2.597-in
Cp & Cs are average value at bearing stratum from pile tip extend to 10 Btip

At loading: Qtip=717.7-kp Qtop= 840.0-kp Qside= 122.3-kp
Xtip=2.597-in Xtop= 2.759-in Xshaft= 0.162-in

LOAD - TOTAL SETTLEMENT RELATION (from t-z, and q-w curves):

Based on Vesic Method (1977)

Xtop -in	Xshaft -in	Xtip -in	Qtip -kp	Qside -kp	Qtotal -kp
0.0003	0.0003	0.0000	0.9	0.7	1.7
0.0409	0.0084	0.0325	20.4	41.8	62.2
0.0607	0.0120	0.0487	30.1	57.7	87.8
0.0802	0.0153	0.0649	39.9	70.9	110.8
0.0996	0.0184	0.0812	49.6	81.9	131.5
0.1187	0.0213	0.0974	59.3	90.9	150.2
0.1376	0.0240	0.1136	69.0	98.2	167.2
0.1564	0.0266	0.1299	78.7	104.0	182.7
0.1751	0.0290	0.1461	88.3	108.7	197.0
0.1937	0.0313	0.1623	97.9	112.3	210.3
0.2121	0.0336	0.1785	107.5	115.2	222.7
0.2305	0.0357	0.1948	117.0	117.3	234.3
0.2488	0.0378	0.2110	126.5	118.9	245.4
0.2671	0.0399	0.2272	135.9	120.1	256.0
0.2853	0.0418	0.2435	145.2	120.9	266.1
0.3035	0.0438	0.2597	154.5	121.5	276.0
0.3216	0.0457	0.2759	163.7	121.8	285.6
0.3397	0.0476	0.2922	172.9	122.1	294.9
0.3578	0.0494	0.3084	181.9	122.2	304.1
0.3759	0.0513	0.3246	190.9	122.3	313.1
0.3939	0.0531	0.3409	199.8	122.3	322.0
0.4120	0.0549	0.3571	208.6	122.2	330.8
0.4299	0.0566	0.3733	217.3	122.2	339.4
0.4479	0.0584	0.3896	225.9	122.1	348.0
0.4659	0.0601	0.4058	234.4	121.9	356.4
0.4838	0.0618	0.4220	242.9	121.8	364.6
0.5017	0.0635	0.4383	251.2	121.5	372.7
0.5196	0.0651	0.4545	259.4	121.3	380.7
0.5374	0.0667	0.4707	267.6	120.9	388.5
0.5553	0.0683	0.4869	275.6	120.5	396.1
0.5731	0.0699	0.5032	283.5	120.0	403.5
0.5908	0.0714	0.5194	291.3	119.5	410.8
0.6086	0.0729	0.5356	299.1	118.9	417.9
0.6263	0.0744	0.5519	306.7	118.2	424.9
0.6440	0.0759	0.5681	314.2	117.5	431.7
0.6616	0.0773	0.5843	321.6	116.8	438.3
0.6793	0.0787	0.6006	328.8	116.1	445.0
0.6969	0.0801	0.6168	336.0	115.5	451.5
0.7145	0.0815	0.6330	343.1	115.0	458.1
0.7322	0.0829	0.6493	350.1	115.2	465.3
0.7498	0.0843	0.6655	356.9	115.1	472.0
0.7674	0.0857	0.6817	363.7	115.0	478.7
0.7850	0.0870	0.6980	370.3	114.9	485.2
0.8025	0.0883	0.7142	376.8	114.8	491.6
0.8200	0.0896	0.7304	383.3	114.7	497.9
0.8375	0.0909	0.7467	389.6	114.6	504.1
0.8550	0.0921	0.7629	395.8	114.5	510.2
0.8725	0.0934	0.7791	401.9	114.3	516.2
0.8899	0.0946	0.7953	407.9	114.2	522.1
0.9074	0.0958	0.8116	413.8	114.1	527.9
0.9248	0.0969	0.8278	419.6	114.0	533.6
0.9421	0.0981	0.8440	425.3	113.8	539.2

Ødetail

0.9595	0.0992	0.8603	430.9	113.7	544.6
0.9768	0.1003	0.8765	436.4	113.6	550.0
0.9942	0.1014	0.8927	441.9	113.4	555.3
1.0114	0.1025	0.9090	447.2	113.3	560.5
1.0287	0.1035	0.9252	452.4	113.2	565.6
1.0460	0.1046	0.9414	457.5	113.0	570.6
1.0632	0.1056	0.9577	462.6	112.9	575.5
1.0805	0.1066	0.9739	467.5	112.8	580.3
1.0977	0.1075	0.9901	472.4	112.7	585.0
1.1149	0.1085	1.0064	477.2	112.5	589.7
1.1320	0.1094	1.0226	481.9	112.4	594.3
1.1492	0.1104	1.0388	486.5	112.3	598.7
1.1663	0.1113	1.0550	491.0	112.2	603.2
1.1835	0.1122	1.0713	495.4	112.0	607.5
1.2006	0.1131	1.0875	499.8	111.9	611.7
1.2177	0.1139	1.1037	504.1	111.8	615.9
1.2347	0.1148	1.1200	508.3	111.7	620.0
1.2518	0.1156	1.1362	512.5	111.6	624.1
1.2688	0.1164	1.1524	516.5	111.5	628.0
1.2859	0.1172	1.1687	520.5	111.4	631.9
1.3029	0.1180	1.1849	524.5	111.3	635.8
1.3199	0.1188	1.2011	528.4	111.2	639.5
1.3369	0.1195	1.2174	532.2	111.0	643.2
1.3539	0.1203	1.2336	535.9	110.9	646.8
1.3709	0.1210	1.2498	539.6	110.8	650.4
1.3878	0.1217	1.2661	543.2	110.6	653.9
1.4047	0.1225	1.2823	546.8	110.5	657.3
1.4217	0.1232	1.2985	550.3	110.4	660.7
1.4386	0.1239	1.3148	553.7	110.3	664.0
1.4555	0.1245	1.3310	557.1	110.2	667.3
1.4724	0.1252	1.3472	560.5	110.1	670.6
1.4893	0.1259	1.3634	563.8	110.0	673.8
1.5062	0.1265	1.3797	567.0	109.9	676.9
1.5231	0.1272	1.3959	570.2	109.8	680.0
1.5399	0.1278	1.4121	573.4	109.7	683.1
1.5568	0.1284	1.4284	576.5	109.6	686.1
1.5736	0.1290	1.4446	579.6	109.5	689.0
1.5905	0.1296	1.4608	582.6	109.4	691.9
1.6073	0.1302	1.4771	585.6	109.2	694.8
1.6241	0.1308	1.4933	588.5	109.1	697.7
1.6409	0.1314	1.5095	591.4	109.0	700.5
1.6577	0.1320	1.5258	594.3	108.9	703.2
1.7584	0.1353	1.6232	610.8	108.3	719.1
2.0926	0.1448	1.9478	658.7	106.2	764.9
2.4246	0.1522	2.2724	696.1	104.1	800.2
2.7534	0.1564	2.5970	717.7	102.1	819.8
3.0772	0.1556	2.9217	714.7	100.0	814.7
3.3951	0.1488	3.2463	682.5	97.9	780.4

At Qwork= 460.00-kp Settlement= 0.71919-in
 At Qwork= 460.00-kp Secant Stiffness Kqx= 639.60-kp/-in
 At Xallow= 1.00-in Q= 557.05-kp

Note: If the program cannot find a result or the result exceeds the upper limit. The result will be displayed as 99999.

SUMMARY:

Total Ultimate Capacity (Down)= 839.983-kp Total Ultimate Capacity (Up)= 89.717-kp
 Total Allowable Capacity (Down)= 440.369-kp Total Allowable Capacity (Up)= 50.871-kp

Weight above Ground= 0.12 Total Pile Weight= 12.02-kp *Soil Weight is not included
 Side Resistance (Down)= 122.263-kp Side Resistance (Up)= 77.692-kp
 Tip Resistance (Down)= 717.720-kp Tip Resistance (Up)= 0.000-kp
 Negative Friction, Qneg= 0.000-kp, which has been subtracted from Total Ultimate Capacity (Down)
 Negative friction does not affect Total Uplift Ultimate Capacity (Up)

N/G! Qallow < Q * Vertical Load, Q= 460.0 -kp

Ødetail

FACTOR OF SAFETY:

F_Sside F_Stip F_Sup F_Sweight

1.5 2.0 2.0 1.0

* F_Storsion = F_Sside

Notes:

* Settlement in the program is Elastic Settlement only. Consolidation Settlement is not calculated!

Length - Pile length, distance from pile top to tip (not from ground surface)

Width or D - Width of pile shaft (pile diameter)

D_s and D_l - Short Side and Long Side of Footing

Area - Section area of pile shaft or tip area of pile

S_v - Vertical stress in soils (It may be limited based on critical depth, Z_{lim} or Z/D)

q_{ult} - Ultimate tip resistance (pressure)

Q_{tip_dw} - Ultimate downward tip resistance (Force or Capacity)

Q_{tip_up} - Ultimate uplift tip resistance for belled pile or uplift plate (Force or Capacity)

Torsion - Ultimate torsion resistance for single pile (Capacity)

dz - Small Segment of Depth for Calculation

Z_s - Soil Depth, Depth from ground surface

Z_p - Pile Depth, Depth from pile top

Prem - Primer of pile shaft

Phi - Soil internal friction angle (between soils)

Kf - Friction factor to convert Phi to Delta

Delta - Ski friction between soil and pile (function of Phi. It is different from Phi)

f_{dw} - Downward Resistance between soil and pile from Delta

f_{up} - Uplift Resistance between soil and pile from Delta

C - Soil cohesion (between soils)

Ca - Adhesion between soil and pile (function of C. It is different from C) Ca=KaKcC

Ka - Adhesion ratio, C/Ca

Kc - Adhesion factor defended by users

Ca_{dw} - Downward adhesion between pile and soil

Ca_{up} - Uplift adhesion between pile and soil

Sf_{dw} - Downward side resistance (sum of friction and adhesion, f_{dw} + Ca_{dw})

Sf_{up} - Uplift side resistance (sum of friction and adhesion, f_{up} + Ca_{up})

Torsion side resistance = (Sf_{dw}+Sf_{up})/2 * pile diameter/2

Weight - Weight of Pile shaft

Q_{neg} - negative friction Resistance

Q_{side} - Ultimate side resistance (Q_{side_dw} or Q_{side_up})

Q_{tip} - Ultimate tip resistance (Q_{tip_dw} or Q_{tip_up} for uplift plate)

Q_{dw} - Ultimate downward capacity (Q_{tip} + Q_{side_dw})

Q_{up} - Ultimate uplift capacity (Weight + Q_{side_up})

E - Elastic modules

X_s - Settlement due to axial deformation of pile shaft

X_{pp} - Settlement due to point load from pile tip

X_{ps} - Settlement due to load from pile shaft

X_{top} - Total settlement, X_s + X_{pp} + X_{ps}

X_{tip} - Tip settlement, X_{pp} + X_{ps}

X_{shaft} - Shaft deformation, X_s

X_{allow} - Allowable settlement specified by users

Q_{work} - Vertical working load applied to pile

Q_{allow} - Vertical allowable load, Q_{ult}/F.S.

SOIL STRESS, SIDE RESISTANCE, & AXIAL FORCE vs DEPTH Based on Ultimate Load Condition

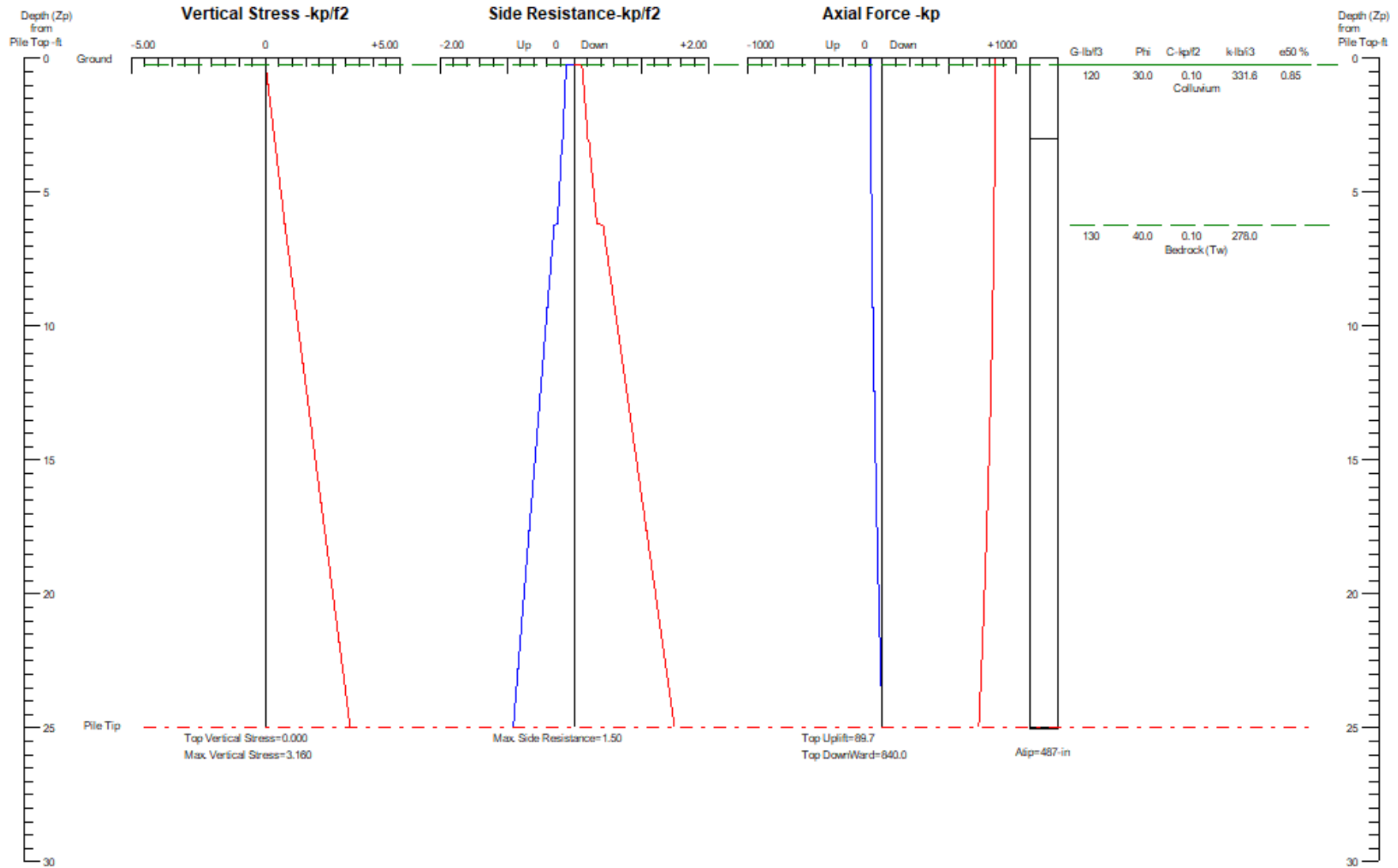

**CivilTech
Software**

**Lot 44
Foundations P1-P8**

Figure 1

Ødetail

Depth vs. Soil Stress, Side Resistance, and Pile Axial Force:

Zp -ft	Sv -kp/f2	Sf_dw -kp/f2	Sf_up -kp/f2	Q_dw -kp	Q_up -kp
0.0	0.00	0.00	0.00	840.0	89.7
0.3	0.00	0.00	0.00	840.0	89.7
0.3	0.00	0.12	0.12	840.0	89.7
0.3	0.01	0.12	0.12	839.9	89.5
0.3	0.01	0.12	0.12	839.9	89.5
0.4	0.02	0.12	0.12	839.9	89.4
0.4	0.03	0.12	0.12	839.8	89.4
0.5	0.03	0.13	0.12	839.8	89.3
0.5	0.04	0.13	0.12	839.8	89.2
0.6	0.04	0.13	0.12	839.7	89.2
0.6	0.05	0.13	0.13	839.7	89.1
0.7	0.06	0.13	0.13	839.6	89.0
0.7	0.06	0.13	0.13	839.6	89.0
0.8	0.07	0.14	0.13	839.6	88.9
0.8	0.07	0.14	0.13	839.5	88.9
0.9	0.08	0.14	0.13	839.5	88.8
0.9	0.09	0.14	0.13	839.4	88.7
1.0	0.09	0.14	0.13	839.4	88.7
1.0	0.10	0.14	0.13	839.3	88.6
1.1	0.10	0.15	0.13	839.3	88.5
1.1	0.11	0.15	0.13	839.2	88.5
1.2	0.12	0.15	0.14	839.2	88.4
1.2	0.12	0.15	0.14	839.2	88.3
1.3	0.13	0.15	0.14	839.1	88.3
1.3	0.13	0.15	0.14	839.1	88.2
1.4	0.14	0.16	0.14	839.0	88.1
1.4	0.15	0.16	0.14	839.0	88.1
1.5	0.15	0.16	0.14	838.9	88.0
1.5	0.16	0.16	0.14	838.9	87.9
1.6	0.16	0.16	0.14	838.8	87.9
1.6	0.17	0.16	0.14	838.8	87.8
1.7	0.18	0.16	0.14	838.7	87.7
1.7	0.18	0.17	0.15	838.7	87.7
1.8	0.19	0.17	0.15	838.6	87.6
1.8	0.19	0.17	0.15	838.6	87.5
1.9	0.20	0.17	0.15	838.5	87.4
1.9	0.21	0.17	0.15	838.5	87.4
2.0	0.21	0.17	0.15	838.4	87.3
2.0	0.22	0.18	0.15	838.3	87.2
2.1	0.22	0.18	0.15	838.3	87.2
2.1	0.23	0.18	0.15	838.2	87.1
2.2	0.24	0.18	0.15	838.2	87.0
2.2	0.24	0.18	0.15	838.1	87.0
2.3	0.25	0.18	0.16	838.1	86.9
2.3	0.25	0.19	0.16	838.0	86.8
2.4	0.26	0.19	0.16	837.9	86.7
2.4	0.26	0.19	0.16	837.9	86.7
2.5	0.27	0.19	0.16	837.8	86.6
2.5	0.28	0.19	0.16	837.8	86.5
2.6	0.28	0.19	0.16	837.7	86.4
2.6	0.29	0.20	0.16	837.7	86.4
2.7	0.29	0.20	0.16	837.6	86.3
2.7	0.30	0.20	0.16	837.5	86.2
2.8	0.31	0.20	0.16	837.5	86.1
2.8	0.31	0.20	0.17	837.4	86.1
2.9	0.32	0.20	0.17	837.3	86.0
2.9	0.32	0.20	0.17	837.3	85.9
3.0	0.33	0.21	0.17	837.2	85.8

Ødetail

3.0	0.34	0.22	0.18	837.2	85.8
3.1	0.34	0.22	0.18	837.1	85.7
3.1	0.35	0.23	0.18	837.0	85.6
3.2	0.35	0.23	0.18	836.9	85.5
3.2	0.36	0.23	0.18	836.9	85.4
3.3	0.37	0.23	0.18	836.8	85.4
3.3	0.37	0.23	0.18	836.7	85.3
3.4	0.38	0.24	0.18	836.7	85.2
3.4	0.38	0.24	0.19	836.6	85.1
3.5	0.39	0.24	0.19	836.5	85.0
3.5	0.40	0.24	0.19	836.4	85.0
3.6	0.40	0.24	0.19	836.4	84.9
3.6	0.41	0.24	0.19	836.3	84.8
3.7	0.41	0.25	0.19	836.2	84.7
3.7	0.42	0.25	0.19	836.1	84.6
3.8	0.43	0.25	0.19	836.1	84.5
3.8	0.43	0.25	0.19	836.0	84.5
3.9	0.44	0.25	0.20	835.9	84.4
3.9	0.44	0.26	0.20	835.8	84.3
4.0	0.45	0.26	0.20	835.7	84.2
4.0	0.46	0.26	0.20	835.7	84.1
4.1	0.46	0.26	0.20	835.6	84.0
4.1	0.47	0.26	0.20	835.5	83.9
4.2	0.47	0.26	0.20	835.4	83.9
4.2	0.48	0.27	0.20	835.3	83.8
4.3	0.49	0.27	0.20	835.2	83.7
4.3	0.49	0.27	0.20	835.2	83.6
4.4	0.50	0.27	0.21	835.1	83.5
4.4	0.50	0.27	0.21	835.0	83.4
4.5	0.51	0.28	0.21	834.9	83.3
4.5	0.51	0.28	0.21	834.8	83.2
4.6	0.52	0.28	0.21	834.7	83.2
4.6	0.53	0.28	0.21	834.6	83.1
4.7	0.53	0.28	0.21	834.6	83.0
4.7	0.54	0.29	0.21	834.5	82.9
4.8	0.54	0.29	0.21	834.4	82.8
4.8	0.55	0.29	0.22	834.3	82.7
4.9	0.56	0.29	0.22	834.2	82.6
4.9	0.56	0.29	0.22	834.1	82.5
5.0	0.57	0.29	0.22	834.0	82.4
5.0	0.57	0.30	0.22	833.9	82.3
5.1	0.58	0.30	0.22	833.8	82.2
5.1	0.59	0.30	0.22	833.7	82.2
5.2	0.59	0.30	0.22	833.7	82.1
5.2	0.60	0.30	0.22	833.6	82.0
5.3	0.60	0.31	0.23	833.5	81.9
5.3	0.61	0.31	0.23	833.4	81.8
5.4	0.62	0.31	0.23	833.3	81.7
5.4	0.62	0.31	0.23	833.2	81.6
5.5	0.63	0.31	0.23	833.1	81.5
5.5	0.63	0.32	0.23	833.0	81.4
5.6	0.64	0.32	0.23	832.9	81.3
5.6	0.65	0.32	0.23	832.8	81.2
5.7	0.65	0.32	0.23	832.7	81.1
5.7	0.66	0.32	0.23	832.6	81.0
5.8	0.66	0.32	0.24	832.5	80.9
5.8	0.67	0.33	0.24	832.4	80.8
5.9	0.68	0.33	0.24	832.3	80.7
5.9	0.68	0.33	0.24	832.2	80.6
6.0	0.69	0.33	0.24	832.1	80.5
6.0	0.69	0.33	0.24	832.0	80.4
6.1	0.70	0.34	0.24	831.9	80.3
6.1	0.71	0.34	0.24	831.8	80.2
6.2	0.71	0.34	0.24	831.7	80.1
6.2	0.72	0.34	0.25	831.6	80.0
6.3	0.72	0.43	0.30	831.4	79.9
6.3	0.73	0.44	0.30	831.3	79.8

Ødetail

6.4	0.74	0.44	0.30	831.2	79.7
6.4	0.74	0.44	0.30	831.0	79.6
6.4	0.75	0.45	0.30	830.9	79.5
6.5	0.76	0.45	0.31	830.8	79.3
6.5	0.76	0.45	0.31	830.6	79.2
6.6	0.77	0.45	0.31	830.5	79.1
6.6	0.77	0.46	0.31	830.3	79.0
6.7	0.78	0.46	0.31	830.2	78.9
6.7	0.79	0.46	0.31	830.1	78.7
6.8	0.79	0.46	0.32	829.9	78.6
6.8	0.80	0.47	0.32	829.8	78.5
6.9	0.81	0.47	0.32	829.6	78.4
6.9	0.81	0.47	0.32	829.5	78.3
7.0	0.82	0.48	0.32	829.3	78.1
7.0	0.83	0.48	0.32	829.2	78.0
7.1	0.83	0.48	0.33	829.0	77.9
7.1	0.84	0.48	0.33	828.9	77.8
7.2	0.85	0.49	0.33	828.7	77.6
7.2	0.85	0.49	0.33	828.6	77.5
7.3	0.86	0.49	0.33	828.4	77.4
7.3	0.87	0.50	0.33	828.3	77.2
7.4	0.87	0.50	0.34	828.1	77.1
7.4	0.88	0.50	0.34	828.0	77.0
7.5	0.88	0.50	0.34	827.8	76.9
7.5	0.89	0.51	0.34	827.6	76.7
7.6	0.90	0.51	0.34	827.5	76.6
7.6	0.90	0.51	0.34	827.3	76.5
7.7	0.91	0.52	0.34	827.2	76.3
7.7	0.92	0.52	0.35	827.0	76.2
7.8	0.92	0.52	0.35	826.8	76.1
7.8	0.93	0.52	0.35	826.7	75.9
7.9	0.94	0.53	0.35	826.5	75.8
7.9	0.94	0.53	0.35	826.4	75.7
8.0	0.95	0.53	0.35	826.2	75.5
8.0	0.96	0.54	0.36	826.0	75.4
8.1	0.96	0.54	0.36	825.9	75.3
8.1	0.97	0.54	0.36	825.7	75.1
8.2	0.97	0.54	0.36	825.5	75.0
8.2	0.98	0.55	0.36	825.4	74.9
8.3	0.99	0.55	0.36	825.2	74.7
8.3	0.99	0.55	0.37	825.0	74.6
8.4	1.00	0.56	0.37	824.8	74.5
8.4	1.01	0.56	0.37	824.7	74.3
8.5	1.01	0.56	0.37	824.5	74.2
8.5	1.02	0.56	0.37	824.3	74.0
8.6	1.03	0.57	0.37	824.1	73.9
8.6	1.03	0.57	0.38	824.0	73.8
8.7	1.04	0.57	0.38	823.8	73.6
8.7	1.05	0.57	0.38	823.6	73.5
8.8	1.05	0.58	0.38	823.4	73.3
8.8	1.06	0.58	0.38	823.3	73.2
8.9	1.06	0.58	0.38	823.1	73.1
8.9	1.07	0.59	0.39	822.9	72.9
9.0	1.08	0.59	0.39	822.7	72.8
9.0	1.08	0.59	0.39	822.5	72.6
9.1	1.09	0.59	0.39	822.3	72.5
9.1	1.10	0.60	0.39	822.2	72.3
9.2	1.10	0.60	0.39	822.0	72.2
9.2	1.11	0.60	0.39	821.8	72.0
9.3	1.12	0.61	0.40	821.6	71.9
9.3	1.12	0.61	0.40	821.4	71.7
9.4	1.13	0.61	0.40	821.2	71.6
9.4	1.14	0.61	0.40	821.0	71.4
9.5	1.14	0.62	0.40	820.8	71.3
9.5	1.15	0.62	0.40	820.6	71.1
9.6	1.16	0.62	0.41	820.4	71.0
9.6	1.16	0.63	0.41	820.3	70.8

Ødetail

9.7	1.17	0.63	0.41	820.1	70.7
9.7	1.17	0.63	0.41	819.9	70.5
9.8	1.18	0.63	0.41	819.7	70.4
9.8	1.19	0.64	0.41	819.5	70.2
9.9	1.19	0.64	0.42	819.3	70.1
9.9	1.20	0.64	0.42	819.1	69.9
10.0	1.21	0.65	0.42	818.9	69.8
10.0	1.21	0.65	0.42	818.7	69.6
10.1	1.22	0.65	0.42	818.5	69.5
10.1	1.23	0.65	0.42	818.3	69.3
10.2	1.23	0.66	0.43	818.1	69.2
10.2	1.24	0.66	0.43	817.9	69.0
10.3	1.25	0.66	0.43	817.6	68.8
10.3	1.25	0.67	0.43	817.4	68.7
10.4	1.26	0.67	0.43	817.2	68.5
10.4	1.26	0.67	0.43	817.0	68.4
10.5	1.27	0.67	0.44	816.8	68.2
10.5	1.28	0.68	0.44	816.6	68.1
10.6	1.28	0.68	0.44	816.4	67.9
10.6	1.29	0.68	0.44	816.2	67.7
10.7	1.30	0.68	0.44	816.0	67.6
10.7	1.30	0.69	0.44	815.8	67.4
10.8	1.31	0.69	0.44	815.5	67.2
10.8	1.32	0.69	0.45	815.3	67.1
10.9	1.32	0.70	0.45	815.1	66.9
10.9	1.33	0.70	0.45	814.9	66.8
11.0	1.34	0.70	0.45	814.7	66.6
11.0	1.34	0.70	0.45	814.5	66.4
11.1	1.35	0.71	0.45	814.2	66.3
11.1	1.36	0.71	0.46	814.0	66.1
11.2	1.36	0.71	0.46	813.8	65.9
11.2	1.37	0.72	0.46	813.6	65.8
11.3	1.37	0.72	0.46	813.4	65.6
11.3	1.38	0.72	0.46	813.1	65.4
11.4	1.39	0.72	0.46	812.9	65.3
11.4	1.39	0.73	0.47	812.7	65.1
11.5	1.40	0.73	0.47	812.5	64.9
11.5	1.41	0.73	0.47	812.2	64.8
11.6	1.41	0.74	0.47	812.0	64.6
11.6	1.42	0.74	0.47	811.8	64.4
11.7	1.43	0.74	0.47	811.5	64.2
11.7	1.43	0.74	0.48	811.3	64.1
11.8	1.44	0.75	0.48	811.1	63.9
11.8	1.45	0.75	0.48	810.8	63.7
11.9	1.45	0.75	0.48	810.6	63.6
11.9	1.46	0.76	0.48	810.4	63.4
12.0	1.46	0.76	0.48	810.1	63.2
12.0	1.47	0.76	0.49	809.9	63.0
12.1	1.48	0.76	0.49	809.7	62.9
12.1	1.48	0.77	0.49	809.4	62.7
12.2	1.49	0.77	0.49	809.2	62.5
12.2	1.50	0.77	0.49	808.9	62.3
12.3	1.50	0.78	0.49	808.7	62.2
12.3	1.51	0.78	0.49	808.5	62.0
12.4	1.52	0.78	0.50	808.2	61.8
12.4	1.52	0.78	0.50	808.0	61.6
12.5	1.53	0.79	0.50	807.7	61.4
12.5	1.54	0.79	0.50	807.5	61.3
12.6	1.54	0.79	0.50	807.2	61.1
12.6	1.55	0.79	0.50	807.0	60.9
12.6	1.55	0.80	0.51	806.8	60.7
12.7	1.56	0.80	0.51	806.5	60.5
12.7	1.57	0.80	0.51	806.3	60.4
12.8	1.57	0.81	0.51	806.0	60.2
12.8	1.58	0.81	0.51	805.8	60.0
12.9	1.59	0.81	0.51	805.5	59.8
12.9	1.59	0.81	0.52	805.2	59.6

Ødetail

13.0	1.60	0.82	0.52	805.0	59.4
13.0	1.61	0.82	0.52	804.7	59.3
13.1	1.61	0.82	0.52	804.5	59.1
13.1	1.62	0.83	0.52	804.2	58.9
13.2	1.63	0.83	0.52	804.0	58.7
13.2	1.63	0.83	0.53	803.7	58.5
13.3	1.64	0.83	0.53	803.5	58.3
13.3	1.65	0.84	0.53	803.2	58.1
13.4	1.65	0.84	0.53	802.9	57.9
13.4	1.66	0.84	0.53	802.7	57.8
13.5	1.66	0.85	0.53	802.4	57.6
13.5	1.67	0.85	0.54	802.1	57.4
13.6	1.68	0.85	0.54	801.9	57.2
13.6	1.68	0.85	0.54	801.6	57.0
13.7	1.69	0.86	0.54	801.3	56.8
13.7	1.70	0.86	0.54	801.1	56.6
13.8	1.70	0.86	0.54	800.8	56.4
13.8	1.71	0.87	0.54	800.5	56.2
13.9	1.72	0.87	0.55	800.3	56.0
13.9	1.72	0.87	0.55	800.0	55.8
14.0	1.73	0.87	0.55	799.7	55.6
14.0	1.74	0.88	0.55	799.5	55.4
14.1	1.74	0.88	0.55	799.2	55.3
14.1	1.75	0.88	0.55	798.9	55.1
14.2	1.75	0.89	0.56	798.6	54.9
14.2	1.76	0.89	0.56	798.4	54.7
14.3	1.77	0.89	0.56	798.1	54.5
14.3	1.77	0.89	0.56	797.8	54.3
14.4	1.78	0.90	0.56	797.5	54.1
14.4	1.79	0.90	0.56	797.2	53.9
14.5	1.79	0.90	0.57	797.0	53.7
14.5	1.80	0.90	0.57	796.7	53.5
14.6	1.81	0.91	0.57	796.4	53.3
14.6	1.81	0.91	0.57	796.1	53.1
14.7	1.82	0.91	0.57	795.8	52.9
14.7	1.83	0.92	0.57	795.6	52.7
14.8	1.83	0.92	0.58	795.3	52.5
14.8	1.84	0.92	0.58	795.0	52.3
14.9	1.85	0.92	0.58	794.7	52.1
14.9	1.85	0.93	0.58	794.4	51.8
15.0	1.86	0.93	0.58	794.1	51.6
15.0	1.86	0.93	0.58	793.8	51.4
15.1	1.87	0.94	0.59	793.5	51.2
15.1	1.88	0.94	0.59	793.2	51.0
15.2	1.88	0.94	0.59	793.0	50.8
15.2	1.89	0.94	0.59	792.7	50.6
15.3	1.90	0.95	0.59	792.4	50.4
15.3	1.90	0.95	0.59	792.1	50.2
15.4	1.91	0.95	0.59	791.8	50.0
15.4	1.92	0.96	0.60	791.5	49.8
15.5	1.92	0.96	0.60	791.2	49.6
15.5	1.93	0.96	0.60	790.9	49.4
15.6	1.94	0.96	0.60	790.6	49.1
15.6	1.94	0.97	0.60	790.3	48.9
15.7	1.95	0.97	0.60	790.0	48.7
15.7	1.95	0.97	0.61	789.7	48.5
15.8	1.96	0.98	0.61	789.4	48.3
15.8	1.97	0.98	0.61	789.1	48.1
15.9	1.97	0.98	0.61	788.8	47.9
15.9	1.98	0.98	0.61	788.5	47.7
16.0	1.99	0.99	0.61	788.2	47.4
16.0	1.99	0.99	0.62	787.8	47.2
16.1	2.00	0.99	0.62	787.5	47.0
16.1	2.01	1.00	0.62	787.2	46.8
16.2	2.01	1.00	0.62	786.9	46.6
16.2	2.02	1.00	0.62	786.6	46.4
16.3	2.03	1.00	0.62	786.3	46.1

Ødetail

16.3	2.03	1.01	0.63	786.0	45.9
16.4	2.04	1.01	0.63	785.7	45.7
16.4	2.04	1.01	0.63	785.4	45.5
16.5	2.05	1.01	0.63	785.0	45.3
16.5	2.06	1.02	0.63	784.7	45.1
16.6	2.06	1.02	0.63	784.4	44.8
16.6	2.07	1.02	0.64	784.1	44.6
16.7	2.08	1.03	0.64	783.8	44.4
16.7	2.08	1.03	0.64	783.5	44.2
16.8	2.09	1.03	0.64	783.1	43.9
16.8	2.10	1.03	0.64	782.8	43.7
16.9	2.10	1.04	0.64	782.5	43.5
16.9	2.11	1.04	0.64	782.2	43.3
17.0	2.12	1.04	0.65	781.8	43.0
17.0	2.12	1.05	0.65	781.5	42.8
17.1	2.13	1.05	0.65	781.2	42.6
17.1	2.14	1.05	0.65	780.9	42.4
17.2	2.14	1.05	0.65	780.5	42.1
17.2	2.15	1.06	0.65	780.2	41.9
17.3	2.15	1.06	0.66	779.9	41.7
17.3	2.16	1.06	0.66	779.5	41.5
17.4	2.17	1.07	0.66	779.2	41.2
17.4	2.17	1.07	0.66	778.9	41.0
17.5	2.18	1.07	0.66	778.5	40.8
17.5	2.19	1.07	0.66	778.2	40.5
17.6	2.19	1.08	0.67	777.9	40.3
17.6	2.20	1.08	0.67	777.5	40.1
17.7	2.21	1.08	0.67	777.2	39.8
17.7	2.21	1.09	0.67	776.9	39.6
17.8	2.22	1.09	0.67	776.5	39.4
17.8	2.23	1.09	0.67	776.2	39.1
17.9	2.23	1.09	0.68	775.9	38.9
17.9	2.24	1.10	0.68	775.5	38.7
18.0	2.24	1.10	0.68	775.2	38.4
18.0	2.25	1.10	0.68	774.8	38.2
18.1	2.26	1.11	0.68	774.5	38.0
18.1	2.26	1.11	0.68	774.1	37.7
18.2	2.27	1.11	0.68	773.8	37.5
18.2	2.28	1.11	0.69	773.4	37.3
18.3	2.28	1.12	0.69	773.1	37.0
18.3	2.29	1.12	0.69	772.8	36.8
18.4	2.30	1.12	0.69	772.4	36.5
18.4	2.30	1.12	0.69	772.1	36.3
18.5	2.31	1.13	0.69	771.7	36.1
18.5	2.32	1.13	0.70	771.4	35.8
18.6	2.32	1.13	0.70	771.0	35.6
18.6	2.33	1.14	0.70	770.6	35.3
18.7	2.34	1.14	0.70	770.3	35.1
18.7	2.34	1.14	0.70	769.9	34.9
18.8	2.35	1.14	0.70	769.6	34.6
18.8	2.35	1.15	0.71	769.2	34.4
18.8	2.36	1.15	0.71	768.9	34.1
18.9	2.37	1.15	0.71	768.5	33.9
18.9	2.37	1.16	0.71	768.2	33.6
19.0	2.38	1.16	0.71	767.8	33.4
19.0	2.39	1.16	0.71	767.4	33.2
19.1	2.39	1.16	0.72	767.1	32.9
19.1	2.40	1.17	0.72	766.7	32.7
19.2	2.41	1.17	0.72	766.3	32.4
19.2	2.41	1.17	0.72	766.0	32.2
19.3	2.42	1.18	0.72	765.6	31.9
19.3	2.43	1.18	0.72	765.2	31.7
19.4	2.43	1.18	0.73	764.9	31.4
19.4	2.44	1.18	0.73	764.5	31.2
19.5	2.44	1.19	0.73	764.1	30.9
19.5	2.45	1.19	0.73	763.8	30.7
19.6	2.46	1.19	0.73	763.4	30.4

Ødetail

19.6	2.46	1.20	0.73	763.0	30.2
19.7	2.47	1.20	0.73	762.7	29.9
19.7	2.48	1.20	0.74	762.3	29.7
19.8	2.48	1.20	0.74	761.9	29.4
19.8	2.49	1.21	0.74	761.5	29.1
19.9	2.50	1.21	0.74	761.2	28.9
19.9	2.50	1.21	0.74	760.8	28.6
20.0	2.51	1.22	0.74	760.4	28.4
20.0	2.52	1.22	0.75	760.0	28.1
20.1	2.52	1.22	0.75	759.6	27.9
20.1	2.53	1.22	0.75	759.3	27.6
20.2	2.54	1.23	0.75	758.9	27.4
20.2	2.54	1.23	0.75	758.5	27.1
20.3	2.55	1.23	0.75	758.1	26.8
20.3	2.55	1.23	0.76	757.7	26.6
20.4	2.56	1.24	0.76	757.3	26.3
20.4	2.57	1.24	0.76	757.0	26.1
20.5	2.57	1.24	0.76	756.6	25.8
20.5	2.58	1.25	0.76	756.2	25.5
20.6	2.59	1.25	0.76	755.8	25.3
20.6	2.59	1.25	0.77	755.4	25.0
20.7	2.60	1.25	0.77	755.0	24.8
20.7	2.61	1.26	0.77	754.6	24.5
20.8	2.61	1.26	0.77	754.2	24.2
20.8	2.62	1.26	0.77	753.8	24.0
20.9	2.63	1.27	0.77	753.5	23.7
20.9	2.63	1.27	0.78	753.1	23.4
21.0	2.64	1.27	0.78	752.7	23.2
21.0	2.64	1.27	0.78	752.3	22.9
21.1	2.65	1.28	0.78	751.9	22.6
21.1	2.66	1.28	0.78	751.5	22.4
21.2	2.66	1.28	0.78	751.1	22.1
21.2	2.67	1.29	0.78	750.7	21.8
21.3	2.68	1.29	0.79	750.3	21.6
21.3	2.68	1.29	0.79	749.9	21.3
21.4	2.69	1.29	0.79	749.5	21.0
21.4	2.70	1.30	0.79	749.1	20.8
21.5	2.70	1.30	0.79	748.7	20.5
21.5	2.71	1.30	0.79	748.3	20.2
21.6	2.72	1.31	0.80	747.8	19.9
21.6	2.72	1.31	0.80	747.4	19.7
21.7	2.73	1.31	0.80	747.0	19.4
21.7	2.73	1.31	0.80	746.6	19.1
21.8	2.74	1.32	0.80	746.2	18.9
21.8	2.75	1.32	0.80	745.8	18.6
21.9	2.75	1.32	0.81	745.4	18.3
21.9	2.76	1.32	0.81	745.0	18.0
22.0	2.77	1.33	0.81	744.6	17.8
22.0	2.77	1.33	0.81	744.2	17.5
22.1	2.78	1.33	0.81	743.7	17.2
22.1	2.79	1.34	0.81	743.3	16.9
22.2	2.79	1.34	0.82	742.9	16.6
22.2	2.80	1.34	0.82	742.5	16.4
22.3	2.81	1.34	0.82	742.1	16.1
22.3	2.81	1.35	0.82	741.7	15.8
22.4	2.82	1.35	0.82	741.2	15.5
22.4	2.83	1.35	0.82	740.8	15.3
22.5	2.83	1.36	0.83	740.4	15.0
22.5	2.84	1.36	0.83	740.0	14.7
22.6	2.84	1.36	0.83	739.5	14.4
22.6	2.85	1.36	0.83	739.1	14.1
22.7	2.86	1.37	0.83	738.7	13.8
22.7	2.86	1.37	0.83	738.3	13.6
22.8	2.87	1.37	0.83	737.8	13.3
22.8	2.88	1.38	0.84	737.4	13.0
22.9	2.88	1.38	0.84	737.0	12.7
22.9	2.89	1.38	0.84	736.6	12.4

Ødetail

23.0	2.90	1.38	0.84	736.1	12.1
23.0	2.90	1.39	0.84	735.7	11.9
23.1	2.91	1.39	0.84	735.3	11.6
23.1	2.92	1.39	0.85	734.8	11.3
23.2	2.92	1.40	0.85	734.4	11.0
23.2	2.93	1.40	0.85	734.0	10.7
23.3	2.93	1.40	0.85	733.5	10.4
23.3	2.94	1.40	0.85	733.1	10.1
23.4	2.95	1.41	0.85	732.7	9.8
23.4	2.95	1.41	0.86	732.2	9.5
23.5	2.96	1.41	0.86	731.8	9.3
23.5	2.97	1.42	0.86	731.3	9.0
23.6	2.97	1.42	0.86	730.9	8.7
23.6	2.98	1.42	0.86	730.5	8.4
23.7	2.99	1.42	0.86	730.0	8.1
23.7	2.99	1.43	0.87	729.6	7.8
23.8	3.00	1.43	0.87	729.1	7.5
23.8	3.01	1.43	0.87	728.7	7.2
23.9	3.01	1.43	0.87	728.2	6.9
23.9	3.02	1.44	0.87	727.8	6.6
24.0	3.03	1.44	0.87	727.3	6.3
24.0	3.03	1.44	0.88	726.9	6.0
24.1	3.04	1.45	0.88	726.4	5.7
24.1	3.04	1.45	0.88	726.0	5.4
24.2	3.05	1.45	0.88	725.5	5.1
24.2	3.06	1.45	0.88	725.1	4.8
24.3	3.06	1.46	0.88	724.6	4.5
24.3	3.07	1.46	0.88	724.2	4.2
24.4	3.08	1.46	0.89	723.7	3.9
24.4	3.08	1.47	0.89	723.3	3.6
24.5	3.09	1.47	0.89	722.8	3.3
24.5	3.10	1.47	0.89	722.3	3.0
24.6	3.10	1.47	0.89	721.9	2.7
24.6	3.11	1.48	0.89	721.4	2.4
24.7	3.12	1.48	0.90	721.0	2.1
24.7	3.12	1.48	0.90	720.5	1.8
24.8	3.13	1.49	0.90	720.0	1.5
24.8	3.13	1.49	0.90	719.6	1.2
24.9	3.14	1.49	0.90	719.1	0.9
24.9	3.15	1.49	0.90	718.7	0.6
25.0	3.15	1.50	0.91	718.2	0.3
25.0	3.16	1.50	0.91	717.7	0.0

Zs - Soil Depth, Depth from Ground Surface
 Zp - Pile Depth, Depth from Pile Top
 Sv - Vertical Effective Stress in Soils
 Sf_dw - Uplift Side Resistance between Soil and Pile
 Sf_up - Uplift Side Resistance between Soil and Pile
 Q_dw - Downward Axial Force in Pile Shaft (Ultimate Uplift Capacity)
 Q_up - Uplift Axial Force in Pile Shaft (Ultimate Uplift Capacity)

Vertical Load vs. Total Settlement

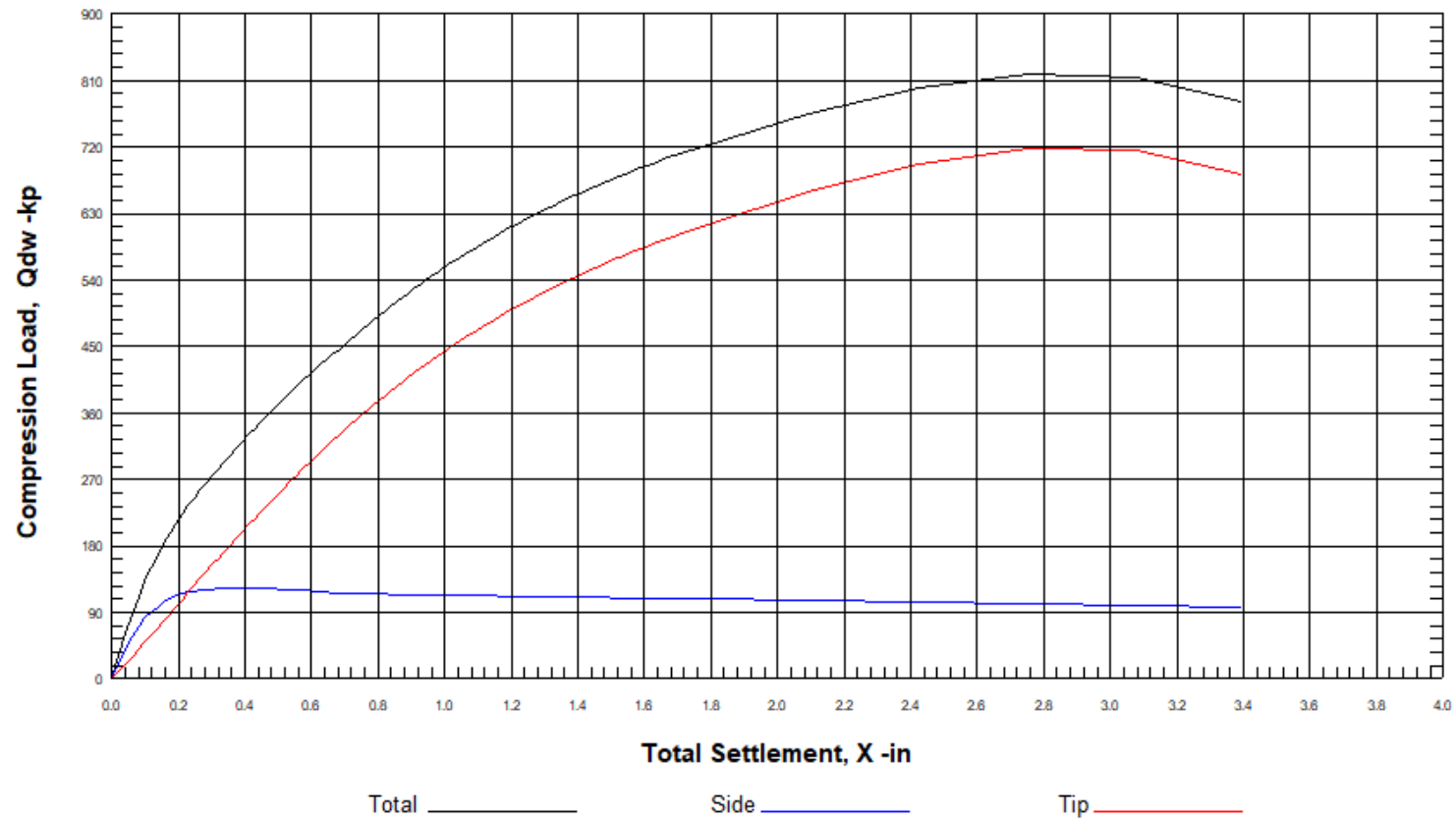

ØLoad_L

Vertical Side and Tip Resistance vs. Total Settlement:

Xtop -in	Qside -kp	Qtip -kp	Qtotal -kp
0.000	0.7	0.9	1.7
0.041	41.8	20.4	62.2
0.061	57.7	30.1	87.8
0.080	70.9	39.9	110.8
0.100	81.9	49.6	131.5
0.119	90.9	59.3	150.2
0.138	98.2	69.0	167.2
0.156	104.0	78.7	182.7
0.175	108.7	88.3	197.0
0.194	112.3	97.9	210.3
0.212	115.2	107.5	222.7
0.231	117.3	117.0	234.3
0.249	118.9	126.5	245.4
0.267	120.1	135.9	256.0
0.285	120.9	145.2	266.1
0.303	121.5	154.5	276.0
0.322	121.8	163.7	285.6
0.340	122.1	172.9	294.9
0.358	122.2	181.9	304.1
0.376	122.3	190.9	313.1
0.394	122.3	199.8	322.0
0.412	122.2	208.6	330.8
0.430	122.2	217.3	339.4
0.448	122.1	225.9	348.0
0.466	121.9	234.4	356.4
0.484	121.8	242.9	364.6
0.502	121.5	251.2	372.7
0.520	121.3	259.4	380.7
0.537	120.9	267.6	388.5
0.555	120.5	275.6	396.1
0.573	120.0	283.5	403.5
0.591	119.5	291.3	410.8
0.609	118.9	299.1	417.9
0.626	118.2	306.7	424.9
0.644	117.5	314.2	431.7
0.662	116.8	321.6	438.3
0.679	116.1	328.8	445.0
0.697	115.5	336.0	451.5
0.715	115.0	343.1	458.1
0.732	115.2	350.1	465.3
0.750	115.1	356.9	472.0
0.767	115.0	363.7	478.7
0.785	114.9	370.3	485.2
0.803	114.8	376.8	491.6
0.820	114.7	383.3	497.9
0.838	114.6	389.6	504.1
0.855	114.5	395.8	510.2
0.872	114.3	401.9	516.2
0.890	114.2	407.9	522.1
0.907	114.1	413.8	527.9
0.925	114.0	419.6	533.6
0.942	113.8	425.3	539.2
0.959	113.7	430.9	544.6
0.977	113.6	436.4	550.0
0.994	113.4	441.9	555.3
1.011	113.3	447.2	560.5
1.029	113.2	452.4	565.6
1.046	113.0	457.5	570.6

ØLoad_L

1.063	112.9	462.6	575.5
1.080	112.8	467.5	580.3
1.098	112.7	472.4	585.0
1.115	112.5	477.2	589.7
1.132	112.4	481.9	594.3
1.149	112.3	486.5	598.7
1.166	112.2	491.0	603.2
1.183	112.0	495.4	607.5
1.201	111.9	499.8	611.7
1.218	111.8	504.1	615.9
1.235	111.7	508.3	620.0
1.252	111.6	512.5	624.1
1.269	111.5	516.5	628.0
1.286	111.4	520.5	631.9
1.303	111.3	524.5	635.8
1.320	111.2	528.4	639.5
1.337	111.0	532.2	643.2
1.354	110.9	535.9	646.8
1.371	110.8	539.6	650.4
1.388	110.6	543.2	653.9
1.405	110.5	546.8	657.3
1.422	110.4	550.3	660.7
1.439	110.3	553.7	664.0
1.456	110.2	557.1	667.3
1.472	110.1	560.5	670.6
1.489	110.0	563.8	673.8
1.506	109.9	567.0	676.9
1.523	109.8	570.2	680.0
1.540	109.7	573.4	683.1
1.557	109.6	576.5	686.1
1.574	109.5	579.6	689.0
1.590	109.4	582.6	691.9
1.607	109.2	585.6	694.8
1.624	109.1	588.5	697.7
1.641	109.0	591.4	700.5
1.658	108.9	594.3	703.2
1.758	108.3	610.8	719.1
2.093	106.2	658.7	764.9
2.425	104.1	696.1	800.2
2.753	102.1	717.7	819.8
3.077	100.0	714.7	814.7
3.395	97.9	682.5	780.4

Xtop - Total Vertical Settlement
Qside - Vertical Side Resistance (Down)
Qtip - Vertical Tip Resistance (Down)
Qtotal - Vertical Total Resistance (Ultimate)

ULTIMATE CAPACITY vs FOUNDATION DEPTH

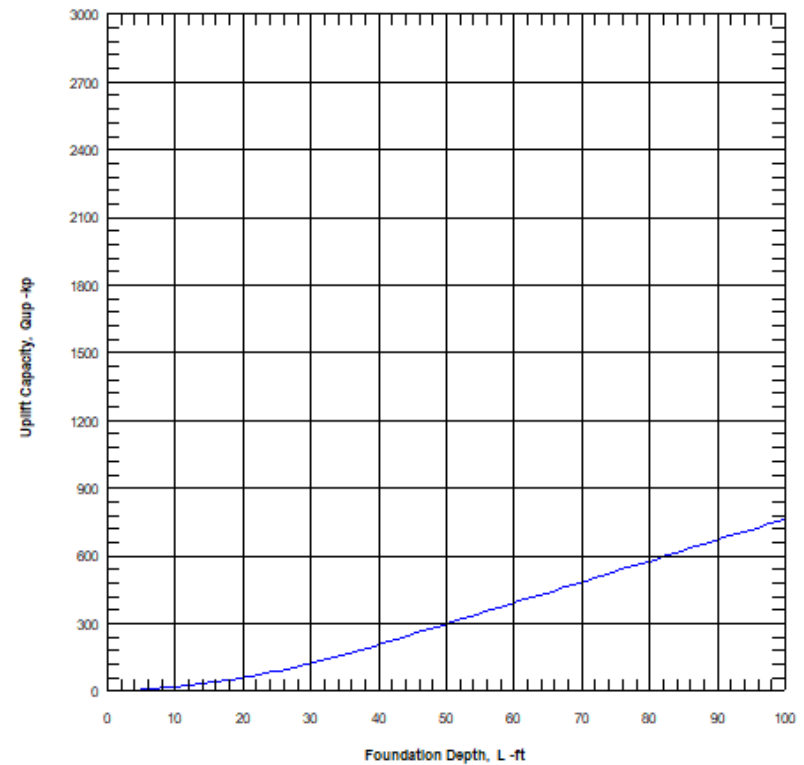
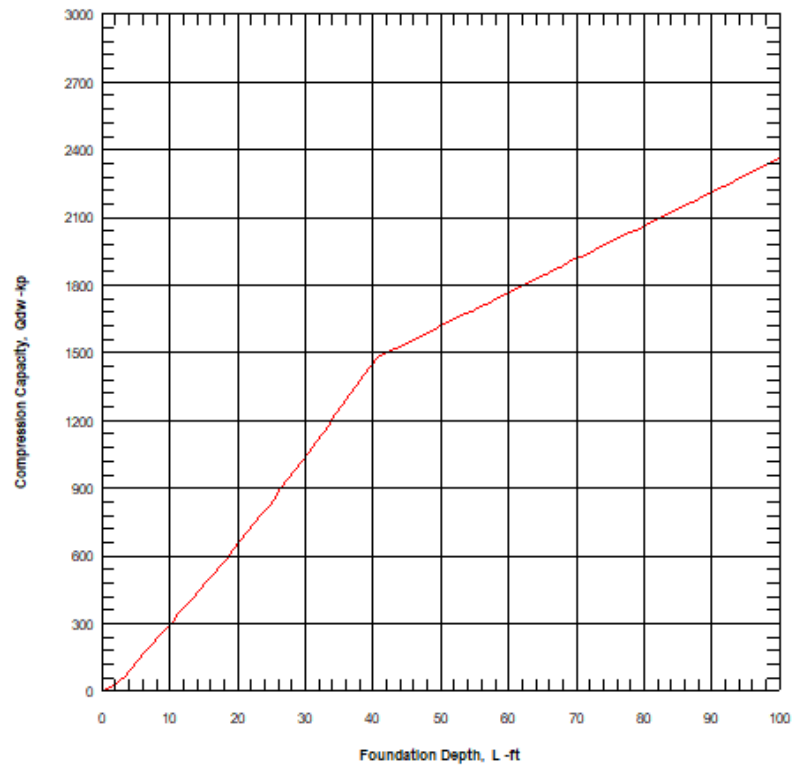

Downward and Uplift Capacity vs Pile Length

The results are for single section pile. Multiple sections may not be correct!

Length -ft	Qtip -kp	Qside -kp	Q_dw -kp	Qd_alw -kp	Weight -kp	Qsid* -kp	Q_up -kp	Qu_alw -kp
0.30	2.70	0.04	2.7	1.38	0.14	0.04	0.18	0.16
1.31	18.85	0.89	19.7	10.02	0.63	0.84	1.47	1.05
2.31	38.64	1.95	40.6	20.62	1.11	1.77	2.88	2.00
3.32	62.79	3.25	66.0	33.56	1.60	2.83	4.43	3.01
4.33	92.18	4.84	97.0	49.32	2.08	4.06	6.14	4.11
5.34	127.78	6.67	134.4	68.33	2.57	5.42	7.99	5.28
6.34	168.49	8.78	177.3	90.10	3.05	6.95	10.00	6.52
7.35	198.17	11.73	209.9	106.91	3.54	8.95	12.49	8.01
8.36	227.83	15.04	242.9	123.95	4.02	11.16	15.18	9.60
9.36	257.48	18.72	276.2	141.22	4.50	13.58	18.08	11.29
10.37	287.13	22.76	309.9	158.74	4.99	16.21	21.19	13.09
11.38	316.73	27.15	343.9	176.46	5.47	19.03	24.50	14.99
12.38	346.41	31.92	378.3	194.48	5.96	22.08	28.03	17.00
13.39	376.05	37.04	413.1	212.72	6.44	25.32	31.77	19.10
14.40	405.68	42.53	448.2	231.19	6.93	28.78	35.70	21.31
15.41	437.05	48.37	485.4	250.77	7.41	32.43	39.84	23.63
16.41	464.93	54.57	519.5	268.85	7.89	36.30	44.19	26.04
17.42	494.58	61.15	555.7	288.06	8.38	40.37	48.75	28.57
18.43	524.25	68.09	592.3	307.52	8.86	44.66	53.52	31.19
19.43	553.83	75.37	629.2	327.16	9.35	49.13	58.48	33.91
20.44	583.48	83.03	666.5	347.10	9.83	53.83	63.67	36.75
21.45	613.12	91.05	704.2	367.26	10.32	58.73	69.05	39.68
22.46	642.82	99.46	742.3	387.72	10.80	63.86	74.66	42.73
23.46	672.48	108.21	780.7	408.38	11.29	69.18	80.46	45.87
24.47	702.08	117.30	819.4	429.24	11.77	74.69	86.46	49.12
25.48	731.72	126.78	858.5	450.38	12.25	80.42	92.68	52.47
26.48	761.30	136.58	897.9	471.70	12.74	86.34	99.08	55.91
27.49	791.03	146.82	937.8	493.39	13.22	92.51	105.73	59.48
28.50	820.68	157.38	978.1	515.26	13.71	98.87	112.57	63.14
29.51	850.23	168.26	1018.5	537.29	14.19	105.40	119.59	66.89
30.51	879.96	179.58	1059.5	559.70	14.68	112.19	126.87	70.77
31.52	909.57	191.21	1100.8	582.26	15.16	119.16	134.32	74.74
32.53	939.21	203.22	1142.4	605.08	15.65	126.33	141.98	78.81
33.53	968.89	215.60	1184.5	628.18	16.13	133.73	149.86	82.99
34.54	998.42	228.28	1226.7	651.40	16.61	141.29	157.90	87.26
35.55	1028.15	241.42	1269.6	675.02	17.10	149.12	166.22	91.66
36.55	1057.72	254.84	1312.6	698.76	17.58	157.11	174.69	96.14
37.56	1087.33	268.64	1356.0	722.75	18.07	165.31	183.37	100.72
38.57	1116.94	282.80	1399.7	747.00	18.55	173.72	192.27	105.41
39.58	1146.58	297.34	1443.9	771.52	19.04	182.35	201.38	110.21
40.58	1164.36	312.23	1476.6	790.33	19.52	191.17	210.69	115.11
41.59	1164.49	327.20	1491.7	800.38	20.00	200.05	220.05	120.03
42.60	1165.73	342.23	1508.0	811.02	20.49	208.95	229.44	124.97
43.60	1165.48	357.11	1522.6	820.82	20.97	217.77	238.75	129.86
44.61	1164.14	372.06	1536.2	830.11	21.46	226.64	248.10	134.78
45.62	1164.17	387.08	1551.3	840.14	21.94	235.54	257.48	139.71
46.63	1165.56	402.09	1567.6	850.84	22.43	244.43	266.85	144.64
47.63	1165.90	417.04	1582.9	860.97	22.91	253.29	276.20	149.56
48.64	1165.40	432.05	1597.4	870.73	23.40	262.19	285.58	154.49
49.65	1166.53	447.10	1613.6	881.33	23.88	271.11	294.99	159.44
50.65	1166.71	462.07	1628.8	891.40	24.36	279.98	304.35	164.36
51.66	1165.97	476.94	1642.9	900.94	24.85	288.79	313.64	169.25
52.67	1164.28	491.63	1655.9	909.89	25.33	297.51	322.84	174.09
53.67	1164.80	506.66	1671.5	920.17	25.82	306.41	332.23	179.02
54.68	1164.50	521.54	1686.0	929.94	26.30	315.24	341.54	183.92
55.69	1166.63	536.90	1703.5	941.25	26.79	324.34	351.12	188.95
56.70	1164.75	551.51	1716.3	950.05	27.27	333.00	360.27	193.77
57.70	1165.43	566.64	1732.1	960.47	27.76	341.96	369.71	198.73
58.71	1165.40	581.61	1747.0	970.44	28.24	350.83	379.07	203.66
59.72	1164.67	596.42	1761.1	979.94	28.72	359.62	388.34	208.53

										ØLoad_L			
60.72	1166.79	611.93	1778.7	991.35	29.21	368.80	398.01	213.61					
61.73	1164.72	626.41	1791.1	999.97	29.69	377.39	407.09	218.39					
62.74	1165.63	641.67	1807.3	1010.59	30.18	386.43	416.61	223.39					
63.75	1165.66	656.50	1822.2	1020.49	30.66	395.22	425.88	228.27					
64.75	1165.38	671.42	1836.8	1030.31	31.15	404.07	435.22	233.18					
65.76	1164.53	686.20	1850.7	1039.73	31.63	412.83	444.46	238.04					
66.77	1166.71	701.70	1868.4	1051.16	32.11	422.01	454.13	243.12					
67.77	1164.74	716.10	1880.8	1059.77	32.60	430.55	463.15	247.87					
68.78	1166.23	731.64	1897.9	1070.88	33.08	439.75	472.84	252.96					
69.79	1166.93	746.73	1913.7	1081.29	33.57	448.70	482.27	257.92					
70.79	1163.33	760.47	1923.8	1088.65	34.05	456.86	490.91	262.48					
71.80	1163.35	775.49	1938.8	1098.67	34.54	465.77	500.31	267.42					
72.81	1166.86	791.70	1958.6	1111.23	35.02	475.35	510.38	272.70					
73.82	1166.01	806.44	1972.4	1120.63	35.51	484.09	519.59	277.55					
74.82	1164.35	820.59	1984.9	1129.23	35.99	492.49	528.48	282.24					
75.83	1167.02	836.80	2003.8	1141.38	36.47	502.07	538.55	287.51					
76.84	1164.48	850.54	2015.0	1149.27	36.96	510.25	547.21	292.08					
77.84	1166.39	866.48	2032.9	1160.85	37.44	519.67	557.12	297.28					
78.85	1162.96	879.72	2042.7	1167.96	37.93	527.56	565.49	301.71					
79.86	1164.11	895.34	2059.5	1178.95	38.41	536.80	575.21	306.81					
80.87	1164.55	910.38	2074.9	1189.19	38.90	545.72	584.62	311.76					
81.87	1165.01	925.71	2090.7	1199.64	39.38	554.80	594.18	316.78					
82.88	1164.73	940.44	2105.2	1209.33	39.87	563.52	603.39	321.63					
83.89	1164.48	955.39	2119.9	1219.17	40.35	572.39	612.74	326.55					
84.89	1163.51	969.70	2133.2	1228.22	40.83	580.89	621.72	331.28					
85.90	1167.61	987.09	2154.7	1241.86	41.32	591.13	632.45	336.88					
86.91	1165.99	1001.06	2167.1	1250.37	41.80	599.44	641.24	341.52					
87.92	1164.01	1014.78	2178.8	1258.52	42.29	607.60	649.88	346.08					
88.92	1167.30	1031.84	2199.1	1271.54	42.77	617.66	660.43	351.60					
89.93	1164.67	1045.14	2209.8	1279.09	43.26	625.58	668.83	356.04					
90.94	1167.03	1061.43	2228.5	1291.13	43.74	635.21	678.95	361.35					
91.94	1164.16	1074.82	2239.0	1298.63	44.22	643.18	687.40	365.81					
92.95	1165.99	1090.83	2256.8	1310.21	44.71	652.65	697.36	371.03					
93.96	1168.01	1107.28	2275.3	1322.19	45.19	662.38	707.57	376.38					
94.96	1163.79	1119.39	2283.2	1328.15	45.68	669.61	715.28	380.48					
95.97	1164.85	1134.97	2299.8	1339.07	46.16	678.82	724.98	385.57					
96.98	1166.11	1151.00	2317.1	1350.39	46.65	688.30	734.94	390.79					
97.99	1166.70	1166.27	2333.0	1360.86	47.13	697.35	744.48	395.81					
98.99	1167.06	1181.43	2348.5	1371.15	47.62	706.33	753.95	400.78					
100.00	1167.17	1196.39	2363.6	1381.18	48.10	715.21	763.31	405.71					

FACTOR OF SAFETY:

FSSide	FStip	FSup	FSweight
1.5	2.0	2.0	1.0

Note: Data can be selected, copied and pasted to Excel to create graphics
 Length - Pile length, distance from pile top to tip (not from ground surface)
 Qtip - Ultimate pile tip resistance
 Qside - Ultimate pile side resistance
 Q_dw - Ultimate pile downward resistance
 Qd_alw - Allowable pile downward resistance
 Weight - Weight of pile shaft
 Qsid* - Ultimate pile side uplift resistance
 Q_up - Ultimate pile uplift resistance
 Qu_alw - Allowable pile uplift resistance

Side Resistance vs. Relative Movement between Soil and Shaft (t-z)

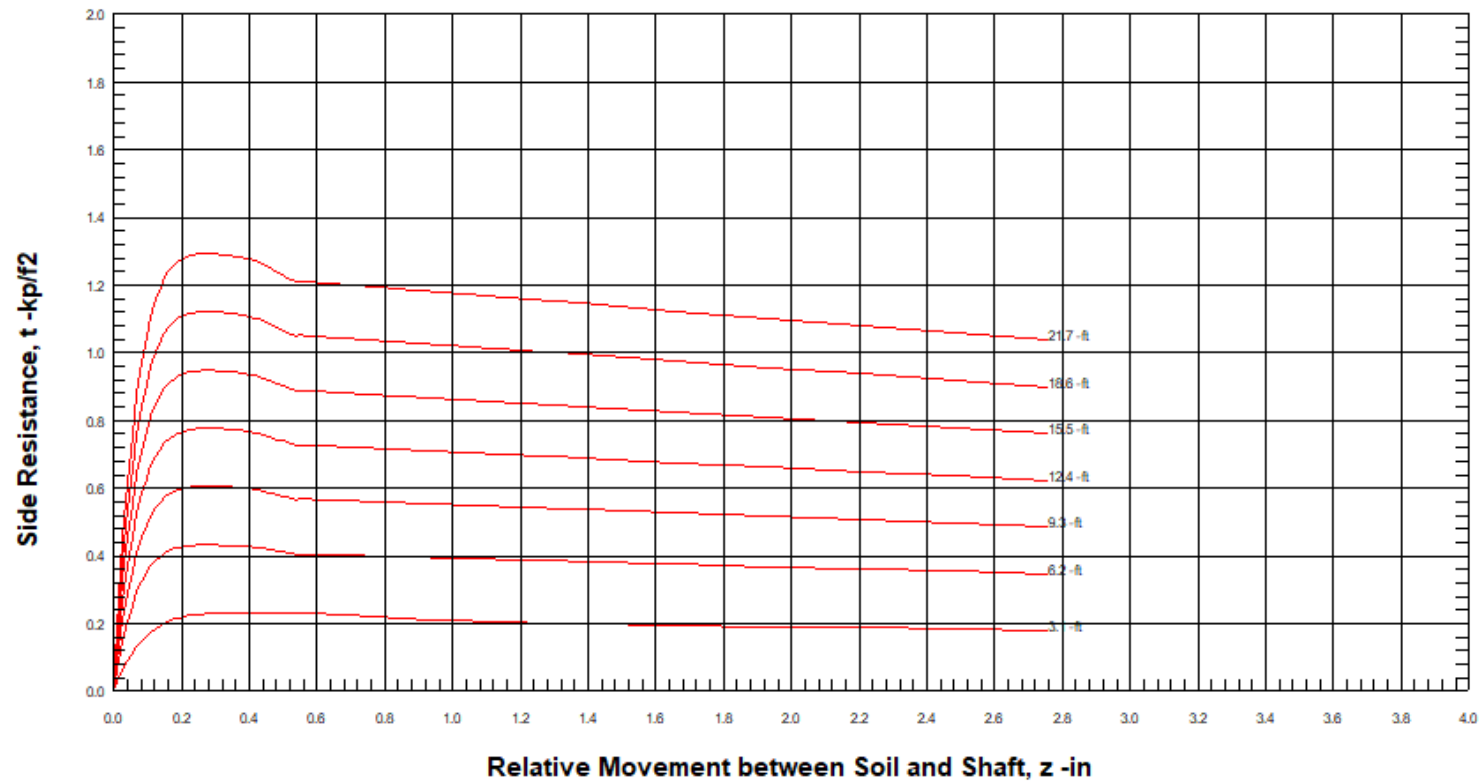

Soil Depth (Zs): 3.1, 6.2, 9.3, 12.4, 15.5, 18.6, 21.7 -ft



ØLoad_L

Side Resistance vs. Relative Movement between Soil and Shaft (t-z)

Zs -ft	t -kp/f2	z -in
3.09	0.00	0.00
3.09	0.06	0.03
3.09	0.09	0.04
3.09	0.11	0.06
3.09	0.13	0.07
3.09	0.15	0.08
3.09	0.16	0.10
3.09	0.17	0.11
3.09	0.19	0.12
3.09	0.19	0.14
3.09	0.20	0.15
3.09	0.21	0.17
3.09	0.21	0.18
3.09	0.22	0.19
3.09	0.22	0.21
3.09	0.22	0.22
3.09	0.23	0.23
3.09	0.23	0.25
3.09	0.23	0.26
3.09	0.23	0.28
3.09	0.23	0.29
3.09	0.23	0.30
3.09	0.23	0.32
3.09	0.23	0.33
3.09	0.23	0.34
3.09	0.23	0.36
3.09	0.23	0.37
3.09	0.23	0.39
3.09	0.23	0.40
3.09	0.23	0.41
3.09	0.23	0.43
3.09	0.23	0.44
3.09	0.23	0.46
3.09	0.23	0.47
3.09	0.23	0.48
3.09	0.23	0.50
3.09	0.23	0.51
3.09	0.23	0.52
3.09	0.23	0.54
3.09	0.23	0.55
3.09	0.23	0.57
3.09	0.23	0.58
3.09	0.23	0.59
3.09	0.23	0.61
3.09	0.23	0.62
3.09	0.23	0.63
3.09	0.23	0.65
3.09	0.23	0.66
3.09	0.23	0.68
3.09	0.23	0.69
3.09	0.22	0.70
3.09	0.22	0.72
3.09	0.22	0.73
3.09	0.22	0.75
3.09	0.22	0.76
3.09	0.22	0.77
3.09	0.22	0.79
3.09	0.22	0.80

ØLoad_L

3.09	0.22	0.81
3.09	0.22	0.83
3.09	0.22	0.84
3.09	0.22	0.86
3.09	0.21	0.87
3.09	0.21	0.88
3.09	0.21	0.90
3.09	0.21	0.91
3.09	0.21	0.92
3.09	0.21	0.94
3.09	0.21	0.95
3.09	0.21	0.97
3.09	0.21	0.98
3.09	0.21	0.99
3.09	0.21	1.01
3.09	0.21	1.02
3.09	0.21	1.03
3.09	0.21	1.05
3.09	0.21	1.06
3.09	0.21	1.08
3.09	0.20	1.09
3.09	0.20	1.10
3.09	0.20	1.12
3.09	0.20	1.13
3.09	0.20	1.15
3.09	0.20	1.16
3.09	0.20	1.17
3.09	0.20	1.19
3.09	0.20	1.20
3.09	0.20	1.21
3.09	0.20	1.23
3.09	0.20	1.24
3.09	0.20	1.26
3.09	0.20	1.27
3.09	0.20	1.28
3.09	0.20	1.30
3.09	0.20	1.38
3.09	0.20	1.66
3.09	0.19	1.93
3.09	0.19	2.21
3.09	0.18	2.48
3.09	0.18	2.76

Zs	t	z
-ft	-kp/f2	-in
6.19	0.00	0.00
6.19	0.15	0.03
6.19	0.21	0.04
6.19	0.25	0.06
6.19	0.29	0.07
6.19	0.32	0.08
6.19	0.35	0.10
6.19	0.37	0.11
6.19	0.39	0.12
6.19	0.40	0.14
6.19	0.41	0.15
6.19	0.42	0.17
6.19	0.42	0.18
6.19	0.43	0.19
6.19	0.43	0.21
6.19	0.43	0.22
6.19	0.43	0.23
6.19	0.43	0.25
6.19	0.43	0.26
6.19	0.43	0.28
6.19	0.43	0.29

ØLoad_L

6.19	0.43	0.30
6.19	0.43	0.32
6.19	0.43	0.33
6.19	0.43	0.34
6.19	0.43	0.36
6.19	0.43	0.37
6.19	0.43	0.39
6.19	0.43	0.40
6.19	0.43	0.41
6.19	0.42	0.43
6.19	0.42	0.44
6.19	0.42	0.46
6.19	0.42	0.47
6.19	0.41	0.48
6.19	0.41	0.50
6.19	0.41	0.51
6.19	0.41	0.52
6.19	0.40	0.54
6.19	0.41	0.55
6.19	0.41	0.57
6.19	0.40	0.58
6.19	0.40	0.59
6.19	0.40	0.61
6.19	0.40	0.62
6.19	0.40	0.63
6.19	0.40	0.65
6.19	0.40	0.66
6.19	0.40	0.68
6.19	0.40	0.69
6.19	0.40	0.70
6.19	0.40	0.72
6.19	0.40	0.73
6.19	0.40	0.75
6.19	0.40	0.76
6.19	0.40	0.77
6.19	0.40	0.79
6.19	0.40	0.80
6.19	0.40	0.81
6.19	0.40	0.83
6.19	0.40	0.84
6.19	0.40	0.86
6.19	0.40	0.87
6.19	0.40	0.88
6.19	0.40	0.90
6.19	0.40	0.91
6.19	0.40	0.92
6.19	0.40	0.94
6.19	0.39	0.95
6.19	0.39	0.97
6.19	0.39	0.98
6.19	0.39	0.99
6.19	0.39	1.01
6.19	0.39	1.02
6.19	0.39	1.03
6.19	0.39	1.05
6.19	0.39	1.06
6.19	0.39	1.08
6.19	0.39	1.09
6.19	0.39	1.10
6.19	0.39	1.12
6.19	0.39	1.13
6.19	0.39	1.15
6.19	0.39	1.16
6.19	0.39	1.17
6.19	0.39	1.19
6.19	0.39	1.20
6.19	0.39	1.21

ØLoad_L

6.19	0.39	1.23
6.19	0.39	1.24
6.19	0.39	1.26
6.19	0.39	1.27
6.19	0.39	1.28
6.19	0.39	1.30
6.19	0.38	1.38
6.19	0.38	1.66
6.19	0.37	1.93
6.19	0.36	2.21
6.19	0.35	2.48
6.19	0.35	2.76

Zs	t	z
-ft	-kp/f2	-in
9.28	0.00	0.00
9.28	0.21	0.03
9.28	0.29	0.04
9.28	0.36	0.06
9.28	0.41	0.07
9.28	0.45	0.08
9.28	0.49	0.10
9.28	0.52	0.11
9.28	0.54	0.12
9.28	0.56	0.14
9.28	0.57	0.15
9.28	0.58	0.17
9.28	0.59	0.18
9.28	0.60	0.19
9.28	0.60	0.21
9.28	0.60	0.22
9.28	0.60	0.23
9.28	0.61	0.25
9.28	0.61	0.26
9.28	0.61	0.28
9.28	0.61	0.29
9.28	0.61	0.30
9.28	0.61	0.32
9.28	0.60	0.33
9.28	0.60	0.34
9.28	0.60	0.36
9.28	0.60	0.37
9.28	0.60	0.39
9.28	0.60	0.40
9.28	0.60	0.41
9.28	0.59	0.43
9.28	0.59	0.44
9.28	0.59	0.46
9.28	0.58	0.47
9.28	0.58	0.48
9.28	0.58	0.50
9.28	0.57	0.51
9.28	0.57	0.52
9.28	0.57	0.54
9.28	0.57	0.55
9.28	0.57	0.57
9.28	0.57	0.58
9.28	0.57	0.59
9.28	0.57	0.61
9.28	0.57	0.62
9.28	0.57	0.63
9.28	0.56	0.65
9.28	0.56	0.66
9.28	0.56	0.68
9.28	0.56	0.69
9.28	0.56	0.70

ØLoad_L

9.28	0.56	0.72
9.28	0.56	0.73
9.28	0.56	0.75
9.28	0.56	0.76
9.28	0.56	0.77
9.28	0.56	0.79
9.28	0.56	0.80
9.28	0.56	0.81
9.28	0.56	0.83
9.28	0.56	0.84
9.28	0.56	0.86
9.28	0.56	0.87
9.28	0.56	0.88
9.28	0.56	0.90
9.28	0.55	0.91
9.28	0.55	0.92
9.28	0.55	0.94
9.28	0.55	0.95
9.28	0.55	0.97
9.28	0.55	0.98
9.28	0.55	0.99
9.28	0.55	1.01
9.28	0.55	1.02
9.28	0.55	1.03
9.28	0.55	1.05
9.28	0.55	1.06
9.28	0.55	1.08
9.28	0.55	1.09
9.28	0.55	1.10
9.28	0.55	1.12
9.28	0.55	1.13
9.28	0.55	1.15
9.28	0.55	1.16
9.28	0.55	1.17
9.28	0.54	1.19
9.28	0.54	1.20
9.28	0.54	1.21
9.28	0.54	1.23
9.28	0.54	1.24
9.28	0.54	1.26
9.28	0.54	1.27
9.28	0.54	1.28
9.28	0.54	1.30
9.28	0.54	1.38
9.28	0.53	1.66
9.28	0.52	1.93
9.28	0.51	2.21
9.28	0.50	2.48
9.28	0.49	2.76

Zs	t	z
-ft	-kp/f2	-in

12.38	0.00	0.00
12.38	0.27	0.03
12.38	0.37	0.04
12.38	0.46	0.06
12.38	0.53	0.07
12.38	0.58	0.08
12.38	0.63	0.10
12.38	0.67	0.11
12.38	0.70	0.12
12.38	0.72	0.14
12.38	0.74	0.15
12.38	0.75	0.17
12.38	0.76	0.18
12.38	0.77	0.19

ØLoad_L

12.38	0.77	0.21
12.38	0.77	0.22
12.38	0.78	0.23
12.38	0.78	0.25
12.38	0.78	0.26
12.38	0.78	0.28
12.38	0.78	0.29
12.38	0.78	0.30
12.38	0.78	0.32
12.38	0.78	0.33
12.38	0.77	0.34
12.38	0.77	0.36
12.38	0.77	0.37
12.38	0.77	0.39
12.38	0.77	0.40
12.38	0.76	0.41
12.38	0.76	0.43
12.38	0.76	0.44
12.38	0.75	0.46
12.38	0.75	0.47
12.38	0.74	0.48
12.38	0.74	0.50
12.38	0.73	0.51
12.38	0.73	0.52
12.38	0.73	0.54
12.38	0.73	0.55
12.38	0.73	0.57
12.38	0.73	0.58
12.38	0.73	0.59
12.38	0.73	0.61
12.38	0.73	0.62
12.38	0.72	0.63
12.38	0.72	0.65
12.38	0.72	0.66
12.38	0.72	0.68
12.38	0.72	0.69
12.38	0.72	0.70
12.38	0.72	0.72
12.38	0.72	0.73
12.38	0.72	0.75
12.38	0.72	0.76
12.38	0.72	0.77
12.38	0.72	0.79
12.38	0.72	0.80
12.38	0.72	0.81
12.38	0.72	0.83
12.38	0.71	0.84
12.38	0.71	0.86
12.38	0.71	0.87
12.38	0.71	0.88
12.38	0.71	0.90
12.38	0.71	0.91
12.38	0.71	0.92
12.38	0.71	0.94
12.38	0.71	0.95
12.38	0.71	0.97
12.38	0.71	0.98
12.38	0.71	0.99
12.38	0.71	1.01
12.38	0.71	1.02
12.38	0.71	1.03
12.38	0.70	1.05
12.38	0.70	1.06
12.38	0.70	1.08
12.38	0.70	1.09
12.38	0.70	1.10
12.38	0.70	1.12

ØLoad_L

12.38	0.70	1.13
12.38	0.70	1.15
12.38	0.70	1.16
12.38	0.70	1.17
12.38	0.70	1.19
12.38	0.70	1.20
12.38	0.70	1.21
12.38	0.70	1.23
12.38	0.70	1.24
12.38	0.70	1.26
12.38	0.69	1.27
12.38	0.69	1.28
12.38	0.69	1.30
12.38	0.69	1.38
12.38	0.68	1.66
12.38	0.66	1.93
12.38	0.65	2.21
12.38	0.64	2.48
12.38	0.62	2.76

Zs	t	z
-ft	-kp/f2	-in
15.47	0.01	0.00
15.47	0.33	0.03
15.47	0.45	0.04
15.47	0.56	0.06
15.47	0.64	0.07
15.47	0.71	0.08
15.47	0.77	0.10
15.47	0.81	0.11
15.47	0.85	0.12
15.47	0.88	0.14
15.47	0.90	0.15
15.47	0.91	0.17
15.47	0.93	0.18
15.47	0.93	0.19
15.47	0.94	0.21
15.47	0.94	0.22
15.47	0.95	0.23
15.47	0.95	0.25
15.47	0.95	0.26
15.47	0.95	0.28
15.47	0.95	0.29
15.47	0.95	0.30
15.47	0.95	0.32
15.47	0.95	0.33
15.47	0.94	0.34
15.47	0.94	0.36
15.47	0.94	0.37
15.47	0.94	0.39
15.47	0.94	0.40
15.47	0.93	0.41
15.47	0.93	0.43
15.47	0.92	0.44
15.47	0.92	0.46
15.47	0.91	0.47
15.47	0.91	0.48
15.47	0.90	0.50
15.47	0.90	0.51
15.47	0.89	0.52
15.47	0.89	0.54
15.47	0.89	0.55
15.47	0.89	0.57
15.47	0.89	0.58
15.47	0.89	0.59
15.47	0.89	0.61

ØLoad_L

15.47	0.88	0.62
15.47	0.88	0.63
15.47	0.88	0.65
15.47	0.88	0.66
15.47	0.88	0.68
15.47	0.88	0.69
15.47	0.88	0.70
15.47	0.88	0.72
15.47	0.88	0.73
15.47	0.88	0.75
15.47	0.88	0.76
15.47	0.88	0.77
15.47	0.88	0.79
15.47	0.87	0.80
15.47	0.87	0.81
15.47	0.87	0.83
15.47	0.87	0.84
15.47	0.87	0.86
15.47	0.87	0.87
15.47	0.87	0.88
15.47	0.87	0.90
15.47	0.87	0.91
15.47	0.87	0.92
15.47	0.87	0.94
15.47	0.87	0.95
15.47	0.86	0.97
15.47	0.86	0.98
15.47	0.86	0.99
15.47	0.86	1.01
15.47	0.86	1.02
15.47	0.86	1.03
15.47	0.86	1.05
15.47	0.86	1.06
15.47	0.86	1.08
15.47	0.86	1.09
15.47	0.86	1.10
15.47	0.86	1.12
15.47	0.86	1.13
15.47	0.85	1.15
15.47	0.85	1.16
15.47	0.85	1.17
15.47	0.85	1.19
15.47	0.85	1.20
15.47	0.85	1.21
15.47	0.85	1.23
15.47	0.85	1.24
15.47	0.85	1.26
15.47	0.85	1.27
15.47	0.85	1.28
15.47	0.85	1.30
15.47	0.84	1.38
15.47	0.82	1.66
15.47	0.81	1.93
15.47	0.79	2.21
15.47	0.78	2.48
15.47	0.76	2.76

Zs	t	z
-ft	-kp/f2	-in
18.56	0.01	0.00
18.56	0.39	0.03
18.56	0.54	0.04
18.56	0.66	0.06
18.56	0.76	0.07
18.56	0.84	0.08
18.56	0.91	0.10

ØLoad_L

18.56	0.96	0.11
18.56	1.00	0.12
18.56	1.04	0.14
18.56	1.06	0.15
18.56	1.08	0.17
18.56	1.09	0.18
18.56	1.10	0.19
18.56	1.11	0.21
18.56	1.12	0.22
18.56	1.12	0.23
18.56	1.12	0.25
18.56	1.12	0.26
18.56	1.12	0.28
18.56	1.12	0.29
18.56	1.12	0.30
18.56	1.12	0.32
18.56	1.12	0.33
18.56	1.12	0.34
18.56	1.12	0.36
18.56	1.11	0.37
18.56	1.11	0.39
18.56	1.11	0.40
18.56	1.10	0.41
18.56	1.10	0.43
18.56	1.09	0.44
18.56	1.09	0.46
18.56	1.08	0.47
18.56	1.07	0.48
18.56	1.07	0.50
18.56	1.06	0.51
18.56	1.05	0.52
18.56	1.05	0.54
18.56	1.05	0.55
18.56	1.05	0.57
18.56	1.05	0.58
18.56	1.05	0.59
18.56	1.05	0.61
18.56	1.05	0.62
18.56	1.05	0.63
18.56	1.05	0.65
18.56	1.04	0.66
18.56	1.04	0.68
18.56	1.04	0.69
18.56	1.04	0.70
18.56	1.04	0.72
18.56	1.04	0.73
18.56	1.04	0.75
18.56	1.04	0.76
18.56	1.04	0.77
18.56	1.04	0.79
18.56	1.03	0.80
18.56	1.03	0.81
18.56	1.03	0.83
18.56	1.03	0.84
18.56	1.03	0.86
18.56	1.03	0.87
18.56	1.03	0.88
18.56	1.03	0.90
18.56	1.03	0.91
18.56	1.03	0.92
18.56	1.03	0.94
18.56	1.02	0.95
18.56	1.02	0.97
18.56	1.02	0.98
18.56	1.02	0.99
18.56	1.02	1.01
18.56	1.02	1.02

ØLoad_L

18.56	1.02	1.03
18.56	1.02	1.05
18.56	1.02	1.06
18.56	1.02	1.08
18.56	1.01	1.09
18.56	1.01	1.10
18.56	1.01	1.12
18.56	1.01	1.13
18.56	1.01	1.15
18.56	1.01	1.16
18.56	1.01	1.17
18.56	1.01	1.19
18.56	1.01	1.20
18.56	1.01	1.21
18.56	1.01	1.23
18.56	1.00	1.24
18.56	1.00	1.26
18.56	1.00	1.27
18.56	1.00	1.28
18.56	1.00	1.30
18.56	0.99	1.38
18.56	0.98	1.66
18.56	0.96	1.93
18.56	0.94	2.21
18.56	0.92	2.48
18.56	0.90	2.76

Zs	t	z
-ft	-kp/f2	-in

21.66	0.01	0.00
21.66	0.45	0.03
21.66	0.62	0.04
21.66	0.76	0.06
21.66	0.88	0.07
21.66	0.97	0.08
21.66	1.05	0.10
21.66	1.11	0.11
21.66	1.16	0.12
21.66	1.19	0.14
21.66	1.22	0.15
21.66	1.25	0.17
21.66	1.26	0.18
21.66	1.27	0.19
21.66	1.28	0.21
21.66	1.29	0.22
21.66	1.29	0.23
21.66	1.29	0.25
21.66	1.29	0.26
21.66	1.29	0.28
21.66	1.29	0.29
21.66	1.29	0.30
21.66	1.29	0.32
21.66	1.29	0.33
21.66	1.29	0.34
21.66	1.29	0.36
21.66	1.28	0.37
21.66	1.28	0.39
21.66	1.28	0.40
21.66	1.27	0.41
21.66	1.27	0.43
21.66	1.26	0.44
21.66	1.25	0.46
21.66	1.25	0.47
21.66	1.24	0.48
21.66	1.23	0.50
21.66	1.22	0.51

ØLoad_L

21.66	1.22	0.52
21.66	1.21	0.54
21.66	1.21	0.55
21.66	1.21	0.57
21.66	1.21	0.58
21.66	1.21	0.59
21.66	1.21	0.61
21.66	1.21	0.62
21.66	1.21	0.63
21.66	1.20	0.65
21.66	1.20	0.66
21.66	1.20	0.68
21.66	1.20	0.69
21.66	1.20	0.70
21.66	1.20	0.72
21.66	1.20	0.73
21.66	1.20	0.75
21.66	1.20	0.76
21.66	1.19	0.77
21.66	1.19	0.79
21.66	1.19	0.80
21.66	1.19	0.81
21.66	1.19	0.83
21.66	1.19	0.84
21.66	1.19	0.86
21.66	1.19	0.87
21.66	1.19	0.88
21.66	1.18	0.90
21.66	1.18	0.91
21.66	1.18	0.92
21.66	1.18	0.94
21.66	1.18	0.95
21.66	1.18	0.97
21.66	1.18	0.98
21.66	1.18	0.99
21.66	1.18	1.01
21.66	1.17	1.02
21.66	1.17	1.03
21.66	1.17	1.05
21.66	1.17	1.06
21.66	1.17	1.08
21.66	1.17	1.09
21.66	1.17	1.10
21.66	1.17	1.12
21.66	1.17	1.13
21.66	1.16	1.15
21.66	1.16	1.16
21.66	1.16	1.17
21.66	1.16	1.19
21.66	1.16	1.20
21.66	1.16	1.21
21.66	1.16	1.23
21.66	1.16	1.24
21.66	1.16	1.26
21.66	1.16	1.27
21.66	1.15	1.28
21.66	1.15	1.30
21.66	1.15	1.38
21.66	1.12	1.66
21.66	1.10	1.93
21.66	1.08	2.21
21.66	1.06	2.48
21.66	1.04	2.76

Zs - Depth from Soil Top
t - Side Resistance
z - Relative Movement between Soil and Shaft

0Load_L

Tip Resistance vs. Tip Movement (q-w)

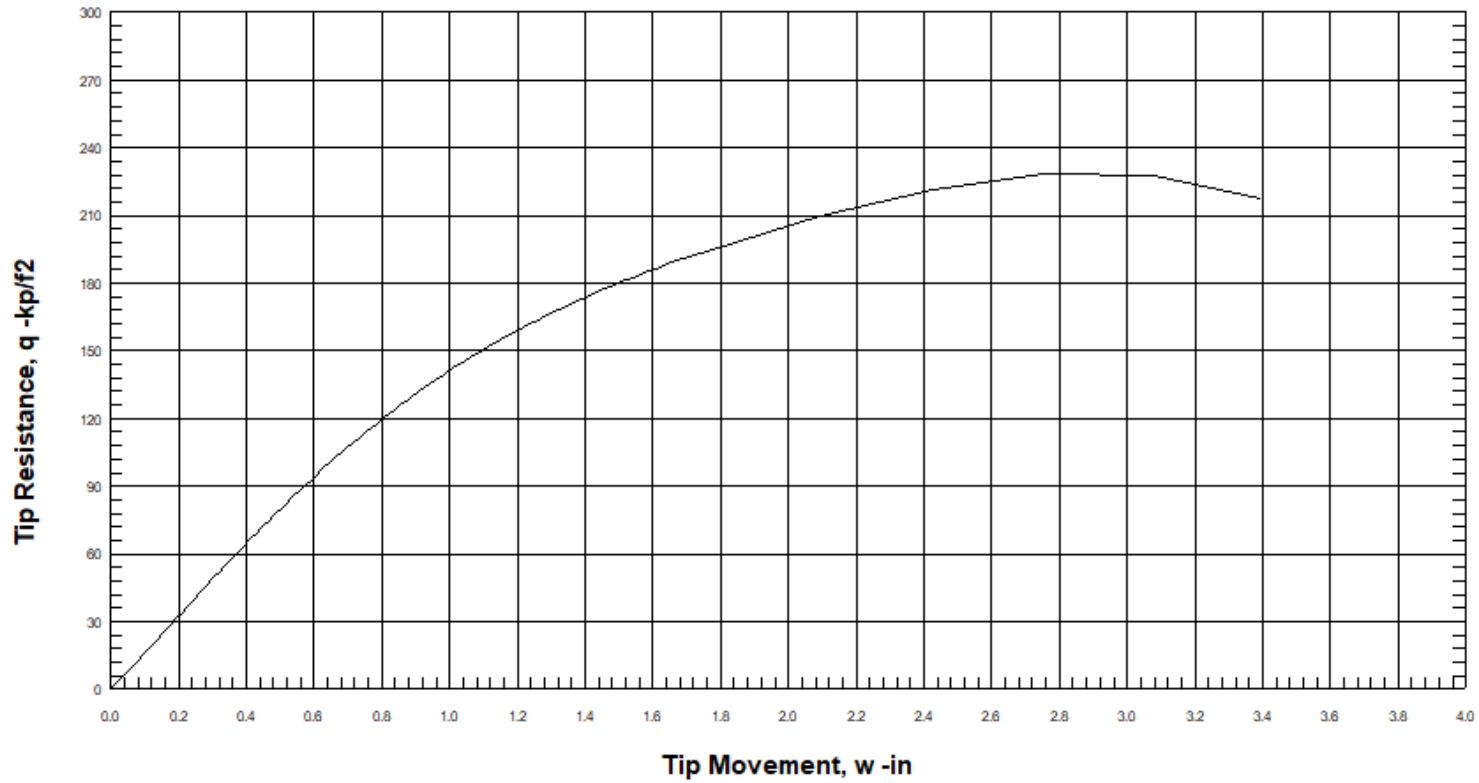

Tip Resistance vs. Tip Movement (q-w)

Depth of Pile Tip from Ground Surface = 24.75-ft

q -kp/f2	w -in
0.30	0.00
6.49	0.04
9.59	0.06
12.69	0.08
15.79	0.10
18.88	0.12
21.97	0.14
25.05	0.16
28.12	0.18
31.18	0.19
34.22	0.21
37.25	0.23
40.26	0.25
43.26	0.27
46.23	0.29
49.18	0.30
52.11	0.32
55.02	0.34
57.90	0.36
60.76	0.38
63.59	0.39
66.39	0.41
69.16	0.43
71.91	0.45
74.62	0.47
77.30	0.48
79.96	0.50
82.58	0.52
85.17	0.54
87.72	0.56
90.25	0.57
92.73	0.59
95.19	0.61
97.61	0.63
100.00	0.64
102.35	0.66
104.67	0.68
106.96	0.70
109.21	0.71
111.42	0.73
113.61	0.75
115.75	0.77
117.87	0.78
119.95	0.80
121.99	0.82
124.00	0.84
125.98	0.86
127.93	0.87
129.84	0.89
131.72	0.91
133.57	0.92
135.38	0.94
137.17	0.96
138.92	0.98
140.64	0.99
142.34	1.01
144.00	1.03

ØLoad_L

145.63	1.05
147.24	1.06
148.81	1.08
150.36	1.10
151.88	1.11
153.37	1.13
154.84	1.15
156.28	1.17
157.70	1.18
159.09	1.20
160.46	1.22
161.80	1.23
163.12	1.25
164.42	1.27
165.69	1.29
166.94	1.30
168.18	1.32
169.39	1.34
170.58	1.35
171.75	1.37
172.90	1.39
174.04	1.40
175.16	1.42
176.26	1.44
177.34	1.46
178.40	1.47
179.45	1.49
180.49	1.51
181.51	1.52
182.51	1.54
183.50	1.56
184.48	1.57
185.44	1.59
186.39	1.61
187.33	1.62
188.26	1.64
189.17	1.66
194.43	1.76
209.66	2.09
221.56	2.42
228.45	2.75
227.50	3.08
217.24	3.40

q - Tip Resistance
w - Tip Movement

LATERAL ANALYSIS

Figure 2

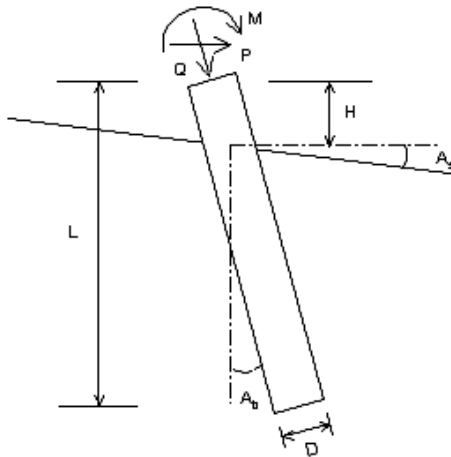

Drilled Pile (dia \leq 24 in. or 61 cm)

Loads:

Load Factor for Vertical Loads= 1.0
 Load Factor for Lateral Loads= 1.0
 Loads Supported by Pile Cap= 0 %
 Shear Condition: Static

(with Load Factor)

Vertical Load, Q= 460.0 -kp
 Shear Load, P= 40.0 -kp
 Slope Restrain St= 0.00000 -in/in

Profile:

Pile Length, L= 25.0 -ft
 Top Height, H= 0.25 -ft
 Slope Angle, As= 0
 Batter Angle, Ab= 0
 Fixed Head Condition

Soil Data:

Depth -ft	Gamma -lb/f3	Phi	C -kp/f2	K -lb/i3	e50 or Dr %	Nspt
0	120	30.0	0.10	331.6	0.85	10
6	130	40.0	0.10	278.0	85.61	50

Pile Data:

Depth -ft	Width -in	Area -in2	Per. -in	I -in4	E -kp/i2	Weight -kp/f
0.0	24	486.7	75.4	16301.6	3000	0.481
3.0	24	486.7	75.4	16301.6	3000	0.481
25.0						

Single Pile Lateral Analysis:

Top Deflection, yt= 0.13300-in
 Max. Moment, M= -185.00-kp-f
 Top Deflection Slope, St= 0.00000
 OK! Top Deflection, 0.1330-in is less than the Allowable Deflection= 1.00-in

Note: If the program cannot find a result or the result exceeds the upper limit. The result will be displayed as 99999.
 The Max. Moment calculated by program is an internal force from the applied load conditions. Structural engineer has to check whether the pile has enough capacity to resist the moment with adequate factor of safety. If not, the pile may fail under the load conditions.



**CivilTech
Software**

**Lot 44
Foundations P1-P8**

Øsummary

ALLPILE 7
LATERAL ANALYSIS SUMMARY OUTPUT
Copyright by CivilTech Software
www.civiltech.com

FACTORS AND CONDITIONS:

Load Factor for Vertical Loads: 1.0
Load Factor for Lateral Loads: 1.0
Loads Supported by Pile Cap: 0 %
Shear Condition: Static

SINGLE PILE:

(with Load Factor)
Vertical Load= 460.00 -kp
Shear= 40.00 -kp
Slope Restrain, St= 0.00 -in/-in

Results:

Top Deflection, yt= 0.13300-in
Max. Moment, M= -185.00-kp-f
Top Deflection Slope, St= 0.00000

Top Deflection, 0.1330-in, OK with the Allowable Deflection= 1.00-in

Note: If the program cannot find a result or the result exceeds the upper limit. The result will be displayed as 99999.

Notes:

- Q - Vertical Load at pile top
- P - Lateral Shear Load at pile top
- M - Moment at pile top
- Xtop - Pile top total settlement
- yt - Pile top deflection
- St - Pile top deflection slope (deflection/unit length)

The Max. Moment calculated by program is an internal moment of shaft due to the loading. EGINEERS have to check whether the pile has enough moment capacity to resist the Max. Moment with adequate factor of safety. If not, the pile may be damaged under the loading.

1 1 1 1 1

PILE MOMENT vs LOADING Single Pile, Khead=5, Kbc=2

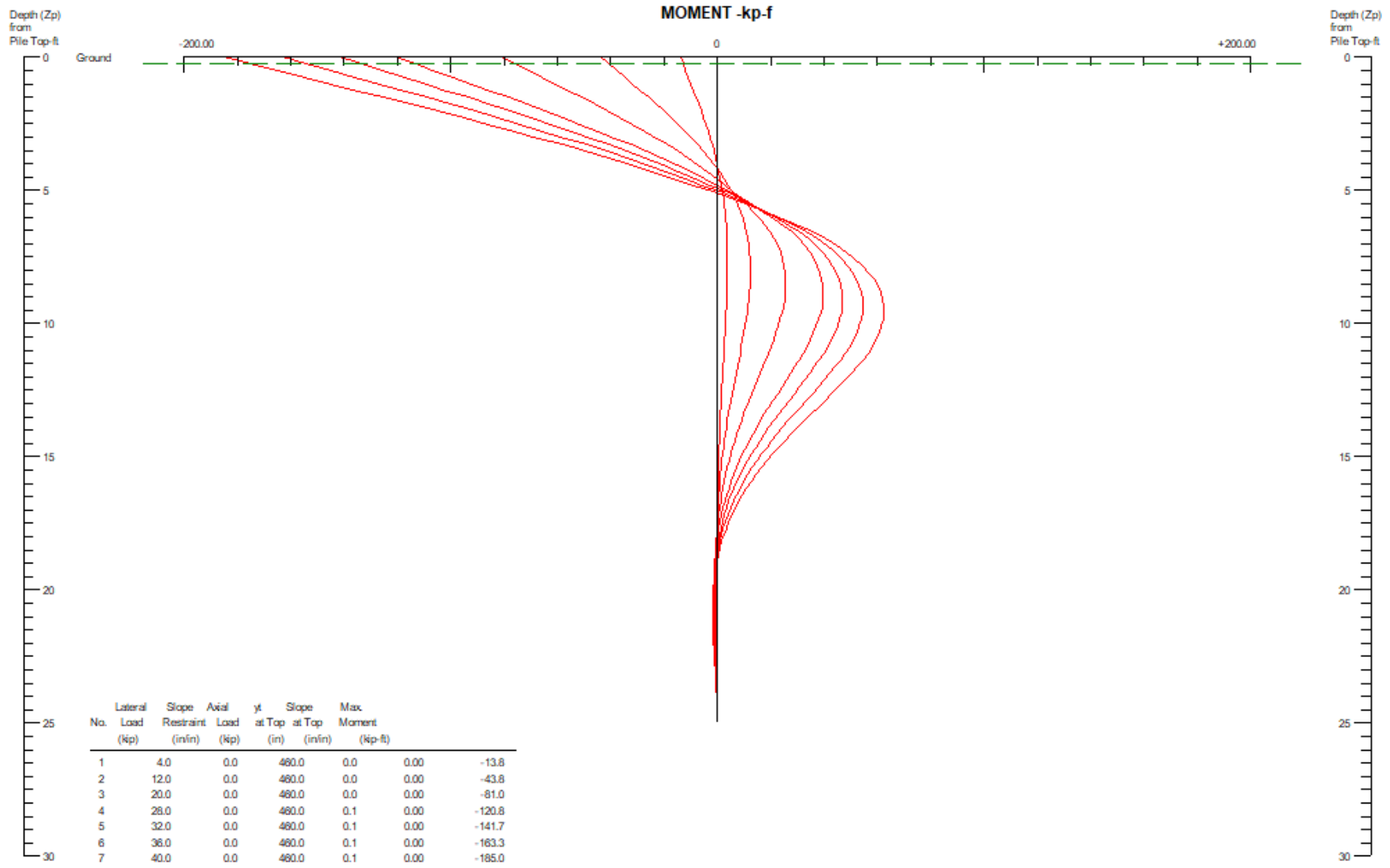

**CivilTech
Software**

**Lot 44
Foundations P1-P8**

Figure 2

PILE DEFLECTION vs LOADING Single Pile, Khead=5, Kbc=2

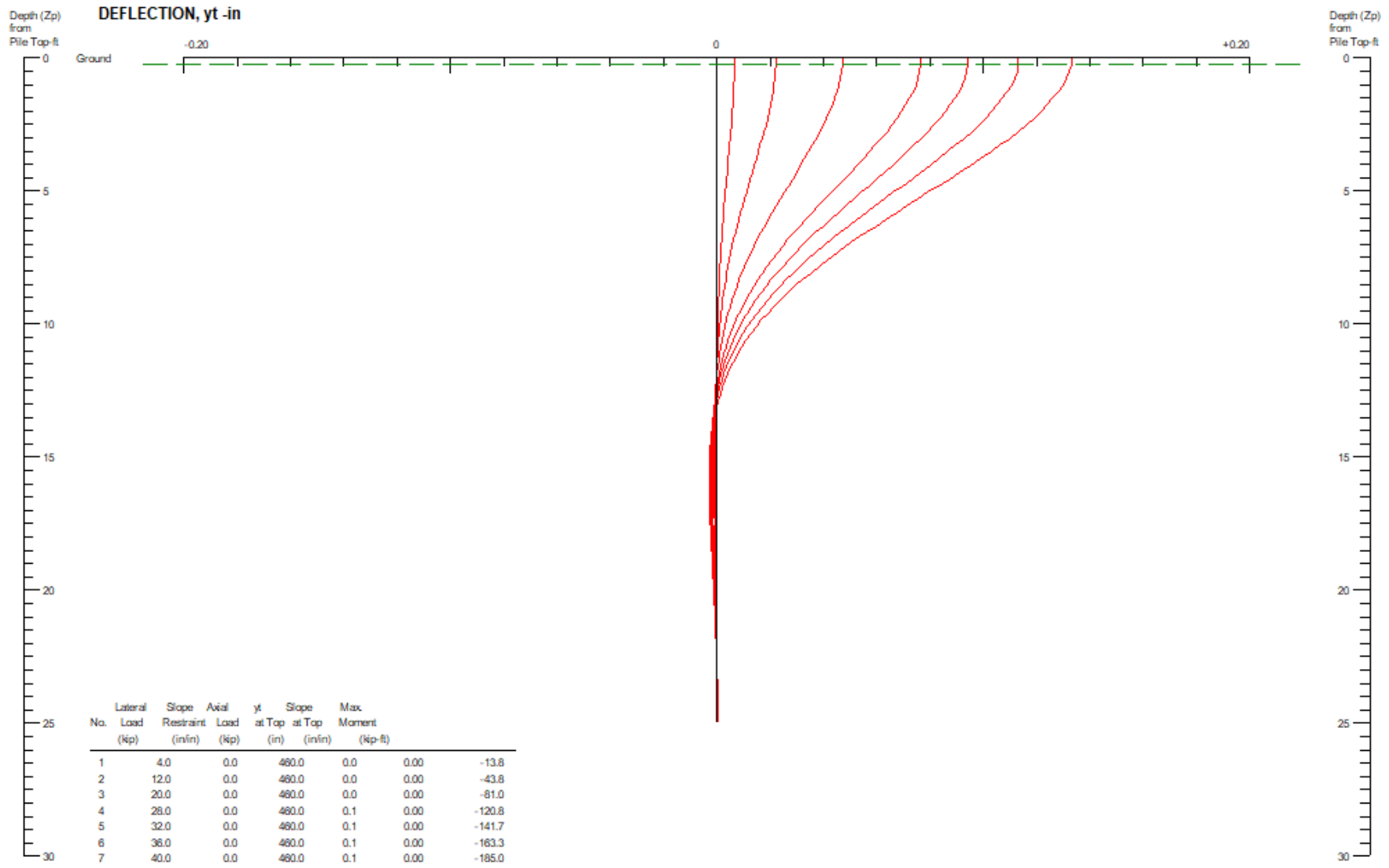

**CivilTech
Software**

**Lot 44
Foundations P1-P8**

Figure 2

PILE DEFLECTION & FORCE vs DEPTH

Single Pile, Khead=5, Kbc=2

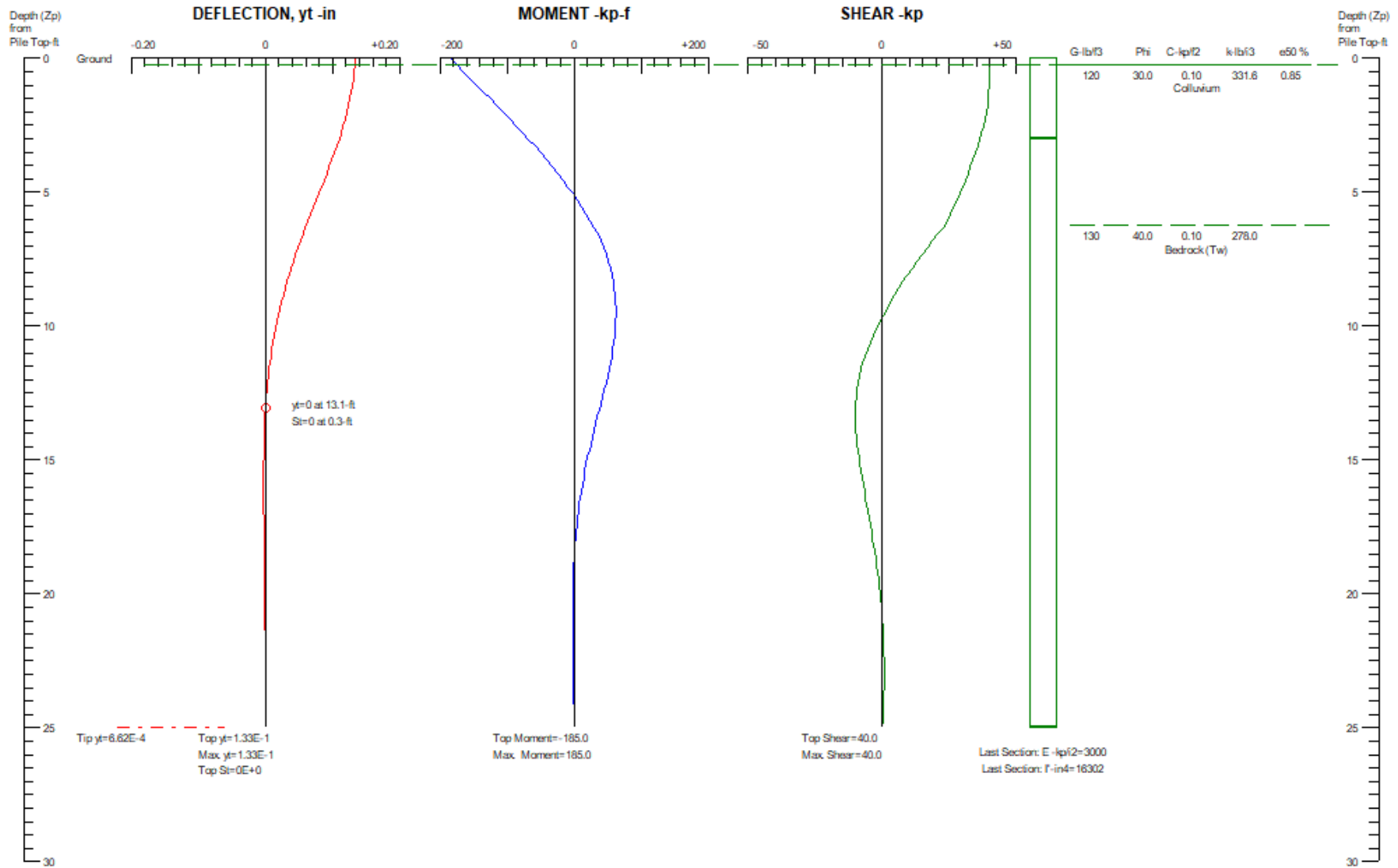

ØLoad_L

Depth vs. Deflection, Moment, Shear, and Slope in Single Pile:

Zp -ft	yt -in	Moment -kp-f	Shear -kp	Pressure -kp/f2	Slope
0.0	0.133	-185.0	40.0	0.0	0.00000
0.3	0.133	-175.0	39.8	0.0	0.00000
0.5	0.132	-165.0	39.7	0.0	-0.00033
0.8	0.131	-155.0	39.7	-0.1	-0.00033
1.0	0.130	-145.0	39.6	-0.1	-0.00033
1.3	0.128	-135.0	39.6	-0.1	-0.00066
1.5	0.126	-125.0	39.6	-0.2	-0.00066
1.8	0.124	-115.0	39.4	-0.2	-0.00066
2.0	0.122	-105.0	38.9	-0.3	-0.00066
2.3	0.119	-95.0	38.3	-0.3	-0.00099
2.5	0.116	-85.8	37.7	-0.3	-0.00099
2.8	0.113	-76.3	37.0	-0.4	-0.00099
3.0	0.110	-67.2	36.3	-0.4	-0.00099
3.3	0.106	-58.2	35.5	-0.4	-0.00132
3.5	0.103	-49.4	34.7	-0.4	-0.00099
3.8	0.099	-40.8	33.8	-0.5	-0.00139
4.0	0.095	-32.5	32.8	-0.5	-0.00125
4.3	0.091	-24.4	31.9	-0.5	-0.00125
4.5	0.087	-16.7	30.9	-0.5	-0.00132
4.8	0.083	-9.1	29.8	-0.5	-0.00129
5.1	0.079	-1.8	28.8	-0.5	-0.00132
5.3	0.075	5.2	27.7	-0.5	-0.00132
5.6	0.071	11.9	26.6	-0.5	-0.00132
5.8	0.067	18.3	25.4	-0.6	-0.00129
6.1	0.064	24.5	24.1	-0.8	-0.00129
6.3	0.060	30.4	22.5	-0.9	-0.00129
6.6	0.056	35.8	20.7	-1.0	-0.00122
6.8	0.052	40.6	18.8	-1.0	-0.00122
7.1	0.049	44.8	16.8	-1.0	-0.00122
7.3	0.045	48.5	14.8	-1.0	-0.00116
7.6	0.042	51.7	12.9	-0.9	-0.00112
7.8	0.038	54.4	11.0	-0.9	-0.00106
8.1	0.035	56.7	9.3	-0.8	-0.00106
8.3	0.032	58.6	7.6	-0.8	-0.00099
8.6	0.029	60.1	6.0	-0.7	-0.00096
8.8	0.026	61.2	4.5	-0.7	-0.00092
9.1	0.024	61.9	3.1	-0.7	-0.00086
9.3	0.021	62.3	1.7	-0.7	-0.00083
9.6	0.019	62.4	0.4	-0.6	-0.00079
9.8	0.017	62.2	-0.9	-0.6	-0.00073
10.1	0.015	61.6	-2.2	-0.6	-0.00066
10.4	0.013	60.7	-3.4	-0.5	-0.00066
10.6	0.011	59.5	-4.5	-0.5	-0.00059
10.9	0.009	58.1	-5.5	-0.5	-0.00053
11.1	0.008	56.4	-6.4	-0.4	-0.00050
11.4	0.006	54.5	-7.3	-0.4	-0.00046
11.6	0.005	52.4	-8.0	-0.3	-0.00042
11.9	0.004	50.3	-8.6	-0.2	-0.00038
12.1	0.003	47.8	-9.1	-0.2	-0.00035
12.4	0.002	45.4	-9.5	-0.1	-0.00031
12.6	0.001	42.8	-9.8	-0.1	-0.00027
12.9	0.000	40.3	-9.9	0.0	-0.00024
13.1	0.000	37.8	-10.0	0.0	-0.00021
13.4	-0.001	35.2	-10.1	0.0	-0.00019
13.6	-0.001	32.6	-10.0	0.1	-0.00016
13.9	-0.002	30.1	-9.9	0.1	-0.00014
14.1	-0.002	27.6	-9.7	0.1	-0.00011
14.4	-0.002	25.2	-9.4	0.2	-0.00009

					θLoad_L
14.6	-0.002	22.8	-9.1	0.2	-0.00007
14.9	-0.003	20.6	-8.8	0.2	-0.00006
15.2	-0.003	18.5	-8.4	0.2	-0.00004
15.4	-0.003	16.4	-8.0	0.2	-0.00003
15.7	-0.003	14.5	-7.6	0.2	-0.00002
15.9	-0.003	12.8	-7.1	0.2	0.00000
16.2	-0.003	11.0	-6.7	0.2	0.00000
16.4	-0.003	9.4	-6.2	0.2	0.00001
16.7	-0.003	8.0	-5.8	0.2	0.00002
16.9	-0.003	6.6	-5.3	0.2	0.00003
17.2	-0.003	5.4	-4.9	0.2	0.00003
17.4	-0.003	4.3	-4.4	0.2	0.00003
17.7	-0.002	3.3	-4.0	0.2	0.00004
17.9	-0.002	2.4	-3.6	0.2	0.00004
18.2	-0.002	1.6	-3.2	0.2	0.00004
18.4	-0.002	0.9	-2.8	0.2	0.00004
18.7	-0.002	0.3	-2.4	0.2	0.00005
18.9	-0.002	-0.2	-2.1	0.2	0.00004
19.2	-0.002	-0.7	-1.8	0.2	0.00005
19.4	-0.001	-1.0	-1.5	0.1	0.00004
19.7	-0.001	-1.3	-1.2	0.1	0.00004
19.9	-0.001	-1.5	-0.9	0.1	0.00004
20.2	-0.001	-1.7	-0.7	0.1	0.00004
20.5	-0.001	-1.8	-0.4	0.1	0.00004
20.7	-0.001	-1.8	-0.2	0.1	0.00004
21.0	-0.001	-1.8	-0.1	0.1	0.00004
21.2	-0.001	-1.8	0.1	0.1	0.00004
21.5	-0.001	-1.7	0.2	0.1	0.00003
21.7	0.000	-1.6	0.3	0.0	0.00003
22.0	0.000	-1.5	0.4	0.0	0.00003
22.2	0.000	-1.4	0.5	0.0	0.00003
22.5	0.000	-1.2	0.6	0.0	0.00003
22.7	0.000	-1.0	0.6	0.0	0.00003
23.0	0.000	-0.9	0.6	0.0	0.00003
23.2	0.000	-0.7	0.6	0.0	0.00003
23.5	0.000	-0.6	0.6	0.0	0.00003
23.7	0.000	-0.4	0.5	0.0	0.00003
24.0	0.000	-0.3	0.5	0.0	0.00003
24.2	0.000	-0.2	0.4	-0.1	0.00003
24.5	0.001	-0.1	0.3	-0.1	0.00003
24.7	0.001	0.0	0.2	-0.1	0.00003
25.0	0.001	0.0	0.0	-0.1	0.00003

Zp - Depth from pile Top
 yt - Pile top deflection
 Moment - Internal moment in pile shaft
 Shear - Internal shear force in pile shaft
 Pressure - Soil-Pile interactive pressure (Arching is considered)
 Slope - Deflection slope at pile top

LATERAL LOAD vs DEFLECTION & MAX. MOMENT

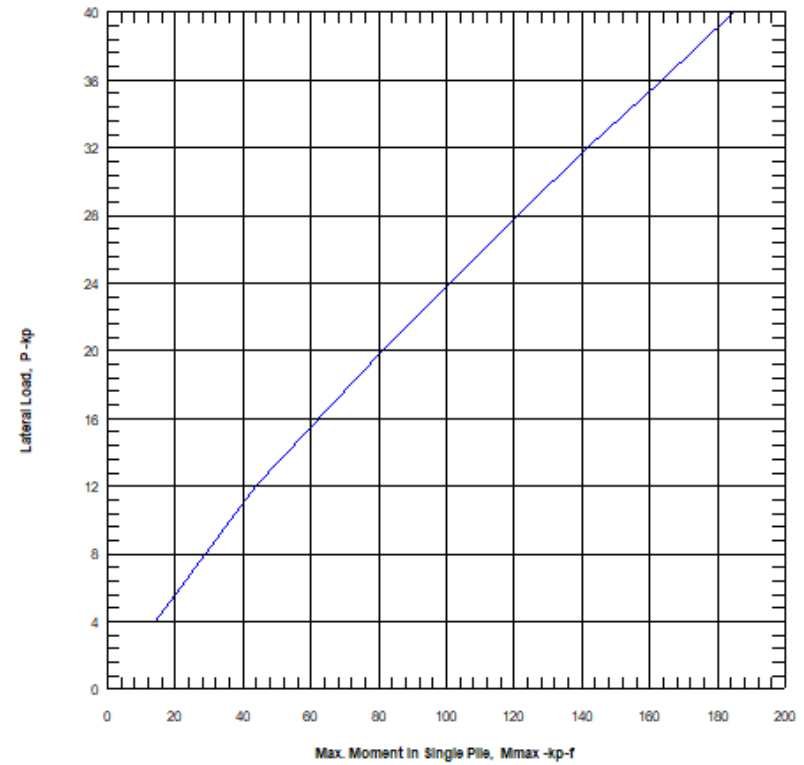
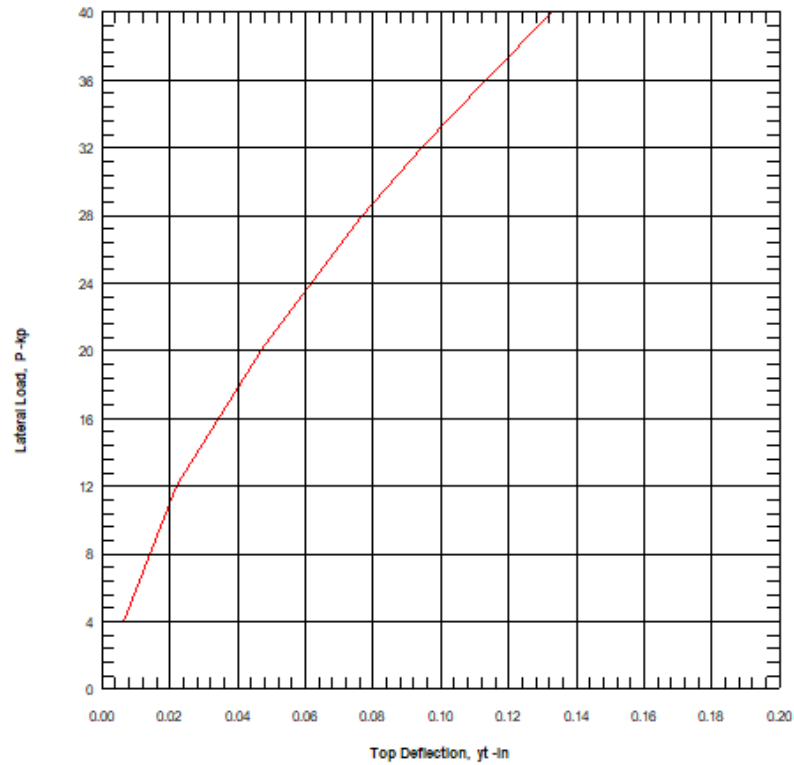

Lateral Load vs Deflection and Max. Moment

P	Q	yt	St	Mmax
-kp	-kp	-in		-kp-f
4.0	460.0	0.01	0.000	-13.8
12.0	460.0	0.02	0.000	-43.8
20.0	460.0	0.05	0.000	-81.0
28.0	460.0	0.08	0.000	-120.8
32.0	460.0	0.09	0.000	-141.7
36.0	460.0	0.11	0.000	-163.3
40.0	460.0	0.13	0.000	-185.0

P - Lateral load at pile top
 Q - Vertical load at pile top
 yt - Lateral deflection at pile top
 St - Deflection slope at pile top
 Mmax - Max. moment in a single pile

Soil Resistance vs. Pile Deflection (p-y)

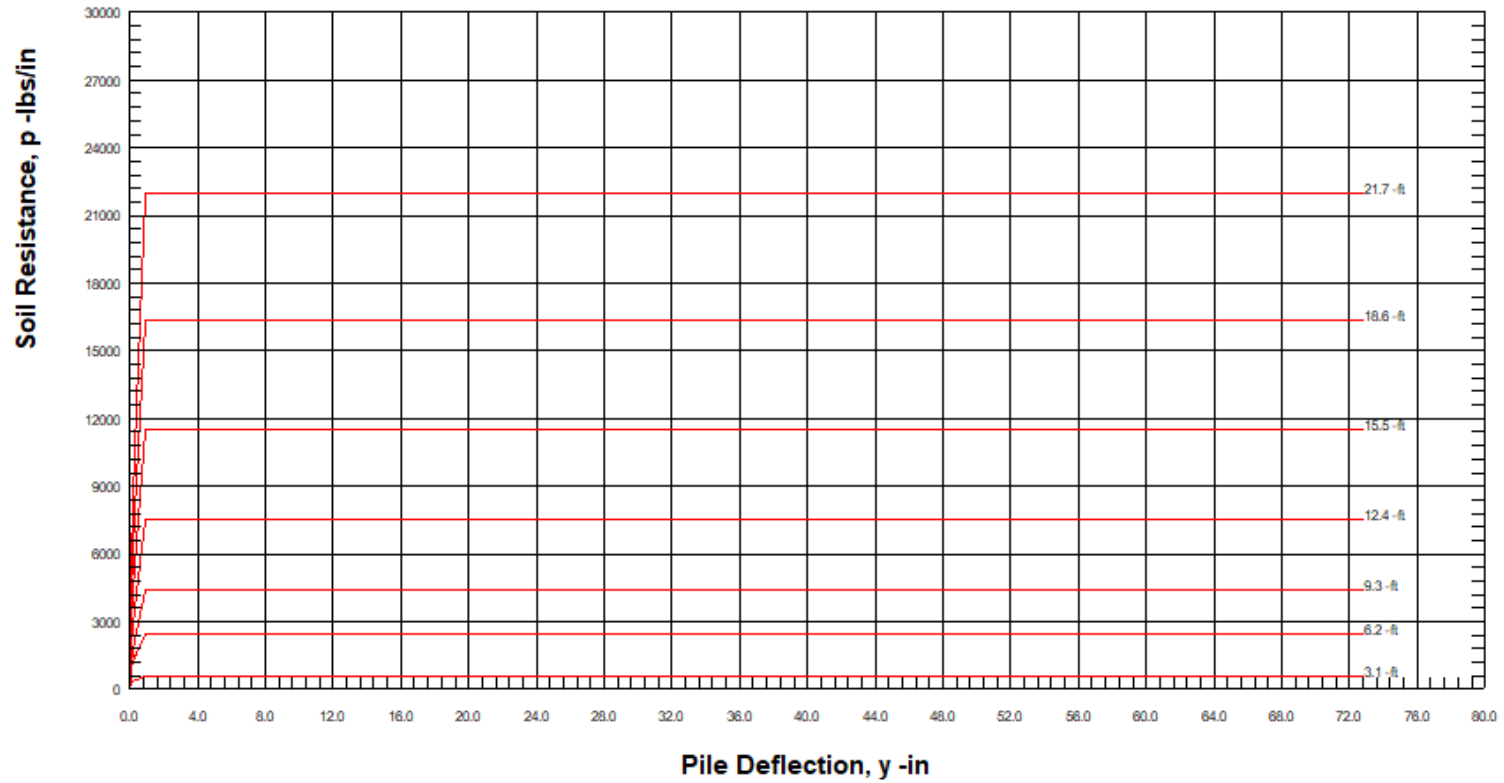

Soil Depth (Zs): 3.1, 6.2, 9.3, 12.4, 15.5, 18.6, 21.7 -ft



Soil Resistance vs. Pile Deflection (p-y)

Zs -ft	p -lbs/in	y -in
3.09	0.0	0.000
3.09	201.0	0.033
3.09	249.2	0.067
3.09	282.6	0.100
3.09	309.0	0.133
3.09	331.2	0.167
3.09	350.4	0.200
3.09	367.6	0.233
3.09	383.1	0.267
3.09	397.4	0.300
3.09	410.6	0.333
3.09	422.9	0.367
3.09	434.5	0.400
3.09	602.9	0.900
3.09	602.9	24.900
3.09	602.9	48.900
3.09	602.9	72.900
6.19	0.0	0.000
6.19	585.7	0.033
6.19	776.3	0.067
6.19	915.4	0.100
6.19	1028.9	0.133
6.19	1126.6	0.167
6.19	1213.3	0.200
6.19	1291.7	0.233
6.19	1363.7	0.267
6.19	1430.6	0.300
6.19	1493.2	0.333
6.19	1552.1	0.367
6.19	1608.0	0.400
6.19	2424.9	0.900
6.19	2424.9	24.900
6.19	2424.9	48.900
6.19	2424.9	72.900
9.28	0.0	0.000
9.28	583.0	0.033
9.28	877.3	0.067
9.28	1114.2	0.100
9.28	1320.1	0.133
9.28	1505.7	0.167
9.28	1676.6	0.200
9.28	1836.1	0.233
9.28	1986.5	0.267
9.28	2129.4	0.300
9.28	2265.9	0.333
9.28	2396.8	0.367
9.28	2523.0	0.400
9.28	4382.4	0.900
9.28	4382.4	24.900
9.28	4382.4	48.900
9.28	4382.4	72.900
12.38	0.0	0.000
12.38	939.9	0.033
12.38	1432.5	0.067

ØLoad_L

12.38	1833.0	0.100
12.38	2183.3	0.133
12.38	2500.6	0.167
12.38	2793.7	0.200
12.38	3068.2	0.233
12.38	3327.7	0.267
12.38	3574.8	0.300
12.38	3811.2	0.333
12.38	4038.6	0.367
12.38	4258.0	0.400
12.38	7494.1	0.900
12.38	7494.1	24.900
12.38	7494.1	48.900
12.38	7494.1	72.900
15.47	0.0	0.000
15.47	1440.2	0.033
15.47	2195.1	0.067
15.47	2808.8	0.100
15.47	3345.7	0.133
15.47	3831.9	0.167
15.47	4281.1	0.200
15.47	4701.7	0.233
15.47	5099.3	0.267
15.47	5477.9	0.300
15.47	5840.3	0.333
15.47	6188.7	0.367
15.47	6525.0	0.400
15.47	11483.9	0.900
15.47	11483.9	24.900
15.47	11483.9	48.900
15.47	11483.9	72.900
18.56	0.0	0.000
18.56	2048.1	0.033
18.56	3121.6	0.067
18.56	3994.3	0.100
18.56	4757.7	0.133
18.56	5449.0	0.167
18.56	6087.8	0.200
18.56	6686.0	0.233
18.56	7251.4	0.267
18.56	7789.8	0.300
18.56	8305.1	0.333
18.56	8800.6	0.367
18.56	9278.7	0.400
18.56	16330.6	0.900
18.56	16330.6	24.900
18.56	16330.6	48.900
18.56	16330.6	72.900
21.66	0.0	0.000
21.66	2408.4	0.033
21.66	4206.8	0.067
21.66	5382.9	0.100
21.66	6411.8	0.133
21.66	7343.4	0.167
21.66	8204.3	0.200
21.66	9010.4	0.233
21.66	9772.5	0.267
21.66	10498.0	0.300
21.66	11192.5	0.333
21.66	11860.2	0.367
21.66	12504.5	0.400
21.66	22008.0	0.900
21.66	22008.0	24.900
21.66	22008.0	48.900

21.66	22008.0	72.900	0Load_L
-------	---------	--------	---------

Zs - Depth from Soil Top
p - Soil Resistance
y - Pile Deflection

FOUNDATION PROFILE & SOIL CONDITIONS

Concrete poured into drilled hole.
Diameter is limited to 24in (61cm).

Depth from Pile Top-ft

Depth	Width-in	A'-in ²	Per.-in	I'-in ⁴	E-kgf/2	W-kgf
0.0	24	486.7	75.4	16301.6	3000	0.481
Concrete (smooth)						
3.0	24	486.7	75.4	16301.6	3000	0.481
Concrete (rough)						

30.0

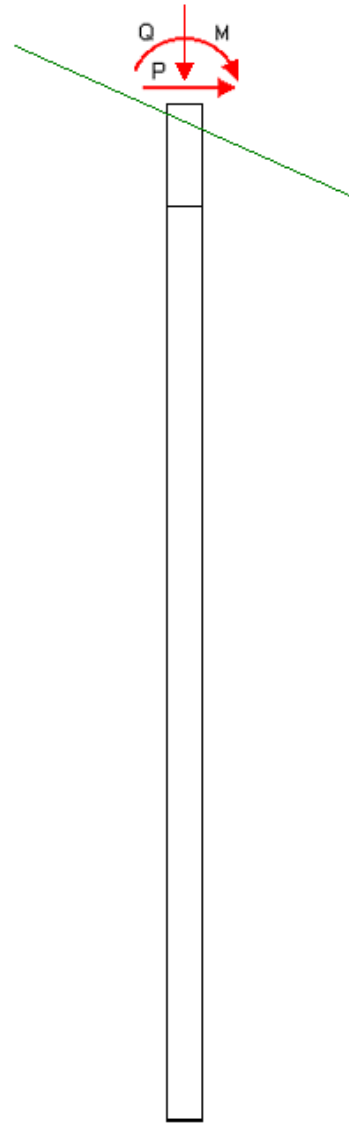

Depth from Pile Top-ft

Depth	γ -lb/ft ³	ϕ	C-kgf/2	k-lb/ft ³	e50 %	Nspt
0.0	125	37.0	.75	122.7		23
Embankment Fill (A)						
10.0	120	30	.1	331.6	.85	10
Colluvium						
16.0	130	40	.1	278		50
Bedrock (Tw)						

30

Batter Angle=0

(Pile diameter not to scale)

Surface Angle=24.0



**CivilTech
Software**

**Lot 44
Foundations P9 & P10**

Figure 1

LATERAL ANALYSIS

Figure 2

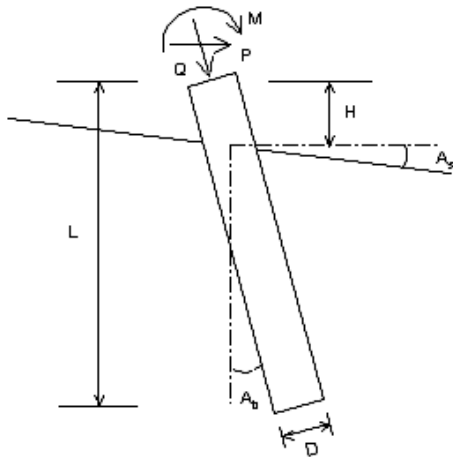

Drilled Pile (dia \leq 24 in. or 61 cm)

Loads:

Load Factor for Vertical Loads= 1.0
 Load Factor for Lateral Loads= 1.0
 Loads Supported by Pile Cap= 0 %
 Shear Condition: Static

(with Load Factor)

Vertical Load, Q= 460.0 -kp
 Shear Load, P= 40.0 -kp
 Slope Restrain St= 0.00000 -in/-in

Profile:

Pile Length, L= 30.0 -ft
 Top Height, H= .5 -ft
 Slope Angle, As= 24.0
 Batter Angle, Ab= 0
 Fixed Head Condition

Soil Data:

Depth -ft	Gamma -lb/f3	Phi	C -kp/f2	K -lb/i3	e50 or Dr %	Nspt
0	125	37.0	.75	122.7	57.53	23
10	120	30	.1	331.6	.85	10
16	130	40	.1	278	85.61	50

Pile Data:

Depth -ft	Width -in	Area -in2	Per. -in	I -in4	E -kp/i2	Weight -kp/f
0.0	24	486.7	75.4	16301.6	3000	0.481
3.0	24	486.7	75.4	16301.6	3000	0.481
30.0						

Single Pile Lateral Analysis:

Top Deflection, yt= 0.27200-in
 Max. Moment, M= -226.67-kp-f
 Top Deflection Slope, St= 0.00000
 OK! Top Deflection, 0.2720-in is less than the Allowable Deflection= 1.00-in

Note: If the program cannot find a result or the result exceeds the upper limit. The result will be displayed as 99999.
 The Max. Moment calculated by program is an internal force from the applied load conditions. Structural engineer has to check whether the pile has enough capacity to resist the moment with adequate factor of safety. If not, the pile may fail under the load conditions.



**CivilTech
Software**

**Lot 44
Foundations P9 & P10**

Øsummary

ALLPILE 7

VERTICAL ANALYSIS SUMMARY OUTPUT
Copyright by CivilTech Software
www.civiltech.com

TOTAL LOADS:

Vertical Load, Q: 460.0 -kp
Vertical Load with Load Factor, Q: 460.0 -kp
Vertical Load with Load factor and Pile Cap, Q= 460.0 -kp
Load Factor for Vertical Load and Torsion= 1.0
Vertical Loads Supported by Pile Cap: 0 %
Load Factor for Vertical Loads: 1.0

PILE PROFILE:

Pile Length, L= 30.0 -ft
Top Height, H= .5 -ft
Slope Angle, As= 24.0
Batter Angle, Ab= 0.00 Batter Factor, Kbat= 1.00

SINGLE PILE:

Kdown= 0.7 Kup= 0.4 Ka= 0.82

Single Pile Vertical Analysis:

Total Ultimate Capacity (Down)= 1039.718-kp Total Ultimate Capacity (Up)= 147.861-kp
Total Allowable Capacity (Down)= 552.100-kp Total Allowable Capacity (Up)= 81.146-kp

Weight above Ground= 0.24 Total Weight= 14.43-kp *Soil Weight is not included
Side Resistance (Down)= 193.448-kp Side Resistance (Up)= 133.431-kp
Tip Resistance (Down)= 846.269-kp Tip Resistance (Up)= 0.000-kp
Negative Friction, Qneg= 0.000-kp, which has been subtracted from Total Ultimate Capacity (Down)
Negative friction does not affect Total Ultimate Capacity (Up)

At Work Load= 460.00-kp, Settlement= 0.47968-in
At Work Load= 460.00-kp, Secant Stiffness Kqx= 958.97-kp/-in
At Allowable Settlement= 1.000000-in, Capacity= 685.52-kp
Work Load, 460.00-kp, OK with the Capacity at Allowable Settlement= 1.00000-in, Capacity= 685.52-kp
Work Load, 460.00-kp, OK with the Allowable Capacity (Down)= 552.10-kp

FACTOR OF SAFETY:

FSside FStip FSuplif FSweight
1.5 2.0 2.0 1.0

Note: If the program cannot find a result or the result exceeds the upper limit. The result will be displayed as 99999.

1 1 1 1 1

0detail

ALLPILE 7
 VERTICAL ANALYSIS DETAILED OUTPUT
 Copyright by CivilTech Software
 www.civiltech.com

Pile Profile and Loading:

Piletype: Drilled Pile (dia <=24 in. or 61 cm)
 Pile Length, L= 30.0 -ft
 Top Height, H= .5 -ft
 Slope Angle, As= 24.0
 Batter Angle, Ab= 0.00

Single Pile, Vertical Analysis:

Vertical Load with Load factor, Q= 460.0 -kp
 Vertical Load with Load factor and Pile Cap, Q= 460.0 -kp
 Load Factor for Vertical Loads= 1.0
 Vertical Loads Supported by Pile Cap: 0 %
 Kdown= 0.7 Kup= 0.4 Ka= 0.82

Bearing stratum from pile tip extending to 10 Diameter of pile, which is=20.0-ft Starting from Pile Tip= 29.5-ft
 From Ztip=29.5 to 49.5-ft Average Properties: Es= 799.92-kp/f2 C=0.10-kp/f2 Friction=40.00 Cp=0.14 Ksand=1.00
 Limits of Max. tip resistance, q_lim= N/A
 Batter Angle, Ab= 0.00 Batter Factor, Kbat= 1.00
 Qtip_dw=846.3-kp based on qult=269.4-kp/f2 and Base Area=3.1-ft2
 Qtip_up=0.0-kp and Base Area=0.0-ft2

TIP RESISTANCE (Down) CALCULATION:

Tip Depth= 29.5-ft Critical Depth Ratio Z/D= 20 Critical Depth= 40.0-ft
 Equivalent Width of Tip= 2.00-ft, Tip Area= 3.14-ft2 Tip Diameter= 2.00-ft
 Bearing stratum from pile tip extending to 10 Diameter of pile. Bearing stratum= 20.00-ft
 Btip: width at pile tip= 2.00-ft (For group pile, it is equivalent width).
 Phi & C are average value in bearing stratum.
 Batter Angle= 0.00, Batter Factor for Tip and Side= 1.00

Ztip -ft	Z/D	Z_lim -ft	q_lim -kp/f2	Width -ft	Area' -ft2	Phi - o	C -kp/f2	Nq	Nc	Sv -kp/f2	qult -kp/f2	Qtip_dw -kp
29.5	20.0	40.0	N/A	2.00	3.14	40.0	0.10	72.0	9.0	3.7	269.4	846.3

Ztip - Depth of pile tip from ground surface (Zs)
 D - Pile average diameter (below ground) for calculation of critical depth. D=2.00-ft
 Z/D - Critical depth (for tip resistances) as ratio of depth/diameter. Vertical stress will be constant below critical depth
 Z_lim - Critical depth, calculated from Z/D (for tip resistances)
 q_lim - Limit of Maximum tip resistance
 Btip: width or diameter at pile tip
 Bearing stratum: A stratum from pile tip extending to some depth. Average soil properties in the stratum are used for bearing calculation

SIDE RESISTANCE (Uplift & Down) CALCULATION:

D -ft	Z/D	Z_lim -ft	Sf_lim -kp/f2	K_dw	K_up	dz -ft
2.00	20.0	40.00	N/A	0.7	0.4	0.059

D - Pile average diameter for calculation of critical depth
 Z/D - Critical depth (for side resistances) as ratio of depth/diameter. Vertical stress will be constant below critical depth
 Z_lim - Critical depth calculated from Z/D (for side resistances)
 Sf_lim - Limit of Maximum side resistance

SIDE RESISTANCE (Up & Down) CALCULATION vs DEPTH:

Calculation is based on segment dz= 0.06

Zs	Prem	Sv	Phi	Kf(<2)	Delta	f_dw	Ødetail f_up	C	Ka	Kc(<2)	Ca_dw	Ca_up	Sf_dw
Sf_up	Weight	Qneg	Q_dw	Q_up	Torsion	-kp/f2	-kp/f2	-kp/f2		Ca	-kp/f2	-kp/f2	-kp/f2
-ft	-ft	-kp/f2	- o	Delta	- o								
-kp/f2	-kp	-kp	-kp	-kp	-kp-f								
29.50	6.28	3.73	40.0	0.80	32.0	1.63	0.93	0.10	1.17	1.00	0.12	0.12	0.00
0.00	0.00	0.00	846.3	0.0	0.0								
29.44	6.28	3.72	40.0	0.80	32.0	1.63	0.93	0.10	1.17	1.00	0.12	0.12	1.75
1.05	0.03	0.00	846.9	0.4	0.5								
29.38	6.28	3.71	40.0	0.80	32.0	1.62	0.93	0.10	1.17	1.00	0.12	0.12	1.74
1.05	0.06	0.00	847.6	0.8	1.0								
29.32	6.28	3.71	40.0	0.80	32.0	1.62	0.93	0.10	1.17	1.00	0.12	0.12	1.74
1.04	0.09	0.00	848.2	1.3	1.6								
29.26	6.28	3.70	40.0	0.80	32.0	1.62	0.92	0.10	1.17	1.00	0.12	0.12	1.73
1.04	0.11	0.00	848.9	1.7	2.1								
29.20	6.28	3.69	40.0	0.80	32.0	1.61	0.92	0.10	1.17	1.00	0.12	0.12	1.73
1.04	0.14	0.00	849.5	2.1	2.6								
29.15	6.28	3.68	40.0	0.80	32.0	1.61	0.92	0.10	1.17	1.00	0.12	0.12	1.73
1.04	0.17	0.00	850.1	2.5	3.1								
29.09	6.28	3.67	40.0	0.80	32.0	1.61	0.92	0.10	1.17	1.00	0.12	0.12	1.72
1.04	0.20	0.00	850.8	2.9	3.6								
29.03	6.28	3.67	40.0	0.80	32.0	1.60	0.92	0.10	1.17	1.00	0.12	0.12	1.72
1.03	0.23	0.00	851.4	3.3	4.1								
28.97	6.28	3.66	40.0	0.80	32.0	1.60	0.91	0.10	1.17	1.00	0.12	0.12	1.72
1.03	0.26	0.00	852.1	3.7	4.6								
28.91	6.28	3.65	40.0	0.80	32.0	1.60	0.91	0.10	1.17	1.00	0.12	0.12	1.71
1.03	0.28	0.00	852.7	4.1	5.1								
28.85	6.28	3.64	40.0	0.80	32.0	1.59	0.91	0.10	1.17	1.00	0.12	0.12	1.71
1.03	0.31	0.00	853.3	4.6	5.7								
28.79	6.28	3.64	40.0	0.80	32.0	1.59	0.91	0.10	1.17	1.00	0.12	0.12	1.71
1.03	0.34	0.00	854.0	5.0	6.2								
28.73	6.28	3.63	40.0	0.80	32.0	1.59	0.91	0.10	1.17	1.00	0.12	0.12	1.70
1.02	0.37	0.00	854.6	5.4	6.7								
28.67	6.28	3.62	40.0	0.80	32.0	1.58	0.91	0.10	1.17	1.00	0.12	0.12	1.70
1.02	0.40	0.00	855.2	5.8	7.2								
28.61	6.28	3.61	40.0	0.80	32.0	1.58	0.90	0.10	1.17	1.00	0.12	0.12	1.70
1.02	0.43	0.00	855.9	6.2	7.7								
28.55	6.28	3.61	40.0	0.80	32.0	1.58	0.90	0.10	1.17	1.00	0.12	0.12	1.69
1.02	0.45	0.00	856.5	6.6	8.2								
28.49	6.28	3.60	40.0	0.80	32.0	1.57	0.90	0.10	1.17	1.00	0.12	0.12	1.69
1.02	0.48	0.00	857.1	7.0	8.7								
28.44	6.28	3.59	40.0	0.80	32.0	1.57	0.90	0.10	1.17	1.00	0.12	0.12	1.69
1.01	0.51	0.00	857.7	7.4	9.2								
28.38	6.28	3.58	40.0	0.80	32.0	1.57	0.90	0.10	1.17	1.00	0.12	0.12	1.68
1.01	0.54	0.00	858.4	7.8	9.7								
28.32	6.28	3.58	40.0	0.80	32.0	1.56	0.89	0.10	1.17	1.00	0.12	0.12	1.68
1.01	0.57	0.00	859.0	8.2	10.2								
28.26	6.28	3.57	40.0	0.80	32.0	1.56	0.89	0.10	1.17	1.00	0.12	0.12	1.68
1.01	0.60	0.00	859.6	8.6	10.7								
28.20	6.28	3.56	40.0	0.80	32.0	1.56	0.89	0.10	1.17	1.00	0.12	0.12	1.67
1.01	0.63	0.00	860.2	9.0	11.2								
28.14	6.28	3.55	40.0	0.80	32.0	1.55	0.89	0.10	1.17	1.00	0.12	0.12	1.67
1.01	0.65	0.00	860.9	9.4	11.7								
28.08	6.28	3.54	40.0	0.80	32.0	1.55	0.89	0.10	1.17	1.00	0.12	0.12	1.67
1.00	0.68	0.00	861.5	9.8	12.2								
28.02	6.28	3.54	40.0	0.80	32.0	1.55	0.88	0.10	1.17	1.00	0.12	0.12	1.66
1.00	0.71	0.00	862.1	10.2	12.7								
27.96	6.28	3.53	40.0	0.80	32.0	1.54	0.88	0.10	1.17	1.00	0.12	0.12	1.66
1.00	0.74	0.00	862.7	10.6	13.2								
27.90	6.28	3.52	40.0	0.80	32.0	1.54	0.88	0.10	1.17	1.00	0.12	0.12	1.66
1.00	0.77	0.00	863.3	11.0	13.7								
27.84	6.28	3.51	40.0	0.80	32.0	1.54	0.88	0.10	1.17	1.00	0.12	0.12	1.65
1.00	0.80	0.00	863.9	11.4	14.2								
27.79	6.28	3.51	40.0	0.80	32.0	1.53	0.88	0.10	1.17	1.00	0.12	0.12	1.65
0.99	0.82	0.00	864.6	11.8	14.6								
27.73	6.28	3.50	40.0	0.80	32.0	1.53	0.87	0.10	1.17	1.00	0.12	0.12	1.65

													Ødetail	
0.99	0.85	0.00	865.2	12.2	15.1									
27.67	6.28	3.49	40.0	0.80	32.0	1.53	0.87	0.10	1.17	1.00	0.12	0.12	1.64	
0.99	0.88	0.00	865.8	12.6	15.6									
27.61	6.28	3.48	40.0	0.80	32.0	1.52	0.87	0.10	1.17	1.00	0.12	0.12	1.64	
0.99	0.91	0.00	866.4	13.0	16.1									
27.55	6.28	3.48	40.0	0.80	32.0	1.52	0.87	0.10	1.17	1.00	0.12	0.12	1.64	
0.99	0.94	0.00	867.0	13.4	16.6									
27.49	6.28	3.47	40.0	0.80	32.0	1.52	0.87	0.10	1.17	1.00	0.12	0.12	1.63	
0.98	0.97	0.00	867.6	13.8	17.1									
27.43	6.28	3.46	40.0	0.80	32.0	1.51	0.86	0.10	1.17	1.00	0.12	0.12	1.63	
0.98	1.00	0.00	868.2	14.2	17.6									
27.37	6.28	3.45	40.0	0.80	32.0	1.51	0.86	0.10	1.17	1.00	0.12	0.12	1.63	
0.98	1.02	0.00	868.8	14.6	18.1									
27.31	6.28	3.44	40.0	0.80	32.0	1.51	0.86	0.10	1.17	1.00	0.12	0.12	1.62	
0.98	1.05	0.00	869.4	15.0	18.5									
27.25	6.28	3.44	40.0	0.80	32.0	1.50	0.86	0.10	1.17	1.00	0.12	0.12	1.62	
0.98	1.08	0.00	870.0	15.4	19.0									
27.19	6.28	3.43	40.0	0.80	32.0	1.50	0.86	0.10	1.17	1.00	0.12	0.12	1.62	
0.97	1.11	0.00	870.6	15.8	19.5									
27.14	6.28	3.42	40.0	0.80	32.0	1.50	0.86	0.10	1.17	1.00	0.12	0.12	1.61	
0.97	1.14	0.00	871.2	16.1	20.0									
27.08	6.28	3.41	40.0	0.80	32.0	1.49	0.85	0.10	1.17	1.00	0.12	0.12	1.61	
0.97	1.17	0.00	871.8	16.5	20.5									
27.02	6.28	3.41	40.0	0.80	32.0	1.49	0.85	0.10	1.17	1.00	0.12	0.12	1.61	
0.97	1.19	0.00	872.4	16.9	20.9									
26.96	6.28	3.40	40.0	0.80	32.0	1.49	0.85	0.10	1.17	1.00	0.12	0.12	1.60	
0.97	1.22	0.00	873.0	17.3	21.4									
26.90	6.28	3.39	40.0	0.80	32.0	1.48	0.85	0.10	1.17	1.00	0.12	0.12	1.60	
0.96	1.25	0.00	873.6	17.7	21.9									
26.84	6.28	3.38	40.0	0.80	32.0	1.48	0.85	0.10	1.17	1.00	0.12	0.12	1.60	
0.96	1.28	0.00	874.2	18.1	22.4									
26.78	6.28	3.38	40.0	0.80	32.0	1.48	0.84	0.10	1.17	1.00	0.12	0.12	1.59	
0.96	1.31	0.00	874.8	18.5	22.8									
26.72	6.28	3.37	40.0	0.80	32.0	1.47	0.84	0.10	1.17	1.00	0.12	0.12	1.59	
0.96	1.34	0.00	875.4	18.9	23.3									
26.66	6.28	3.36	40.0	0.80	32.0	1.47	0.84	0.10	1.17	1.00	0.12	0.12	1.59	
0.96	1.36	0.00	876.0	19.2	23.8									
26.60	6.28	3.35	40.0	0.80	32.0	1.47	0.84	0.10	1.17	1.00	0.12	0.12	1.58	
0.96	1.39	0.00	876.6	19.6	24.3									
26.54	6.28	3.34	40.0	0.80	32.0	1.46	0.84	0.10	1.17	1.00	0.12	0.12	1.58	
0.95	1.42	0.00	877.2	20.0	24.7									
26.48	6.28	3.34	40.0	0.80	32.0	1.46	0.83	0.10	1.17	1.00	0.12	0.12	1.58	
0.95	1.45	0.00	877.7	20.4	25.2									
26.43	6.28	3.33	40.0	0.80	32.0	1.46	0.83	0.10	1.17	1.00	0.12	0.12	1.57	
0.95	1.48	0.00	878.3	20.8	25.7									
26.37	6.28	3.32	40.0	0.80	32.0	1.45	0.83	0.10	1.17	1.00	0.12	0.12	1.57	
0.95	1.51	0.00	878.9	21.1	26.1									
26.31	6.28	3.31	40.0	0.80	32.0	1.45	0.83	0.10	1.17	1.00	0.12	0.12	1.57	
0.95	1.54	0.00	879.5	21.5	26.6									
26.25	6.28	3.31	40.0	0.80	32.0	1.45	0.83	0.10	1.17	1.00	0.12	0.12	1.56	
0.94	1.56	0.00	880.1	21.9	27.1									
26.19	6.28	3.30	40.0	0.80	32.0	1.44	0.82	0.10	1.17	1.00	0.12	0.12	1.56	
0.94	1.59	0.00	880.6	22.3	27.5									
26.13	6.28	3.29	40.0	0.80	32.0	1.44	0.82	0.10	1.17	1.00	0.12	0.12	1.56	
0.94	1.62	0.00	881.2	22.7	28.0									
26.07	6.28	3.28	40.0	0.80	32.0	1.44	0.82	0.10	1.17	1.00	0.12	0.12	1.55	
0.94	1.65	0.00	881.8	23.0	28.5									
26.01	6.28	3.28	40.0	0.80	32.0	1.43	0.82	0.10	1.17	1.00	0.12	0.12	1.55	
0.94	1.68	0.00	882.4	23.4	28.9									
25.95	6.28	3.27	40.0	0.80	32.0	1.43	0.82	0.10	1.17	1.00	0.12	0.12	1.55	
0.93	1.71	0.00	883.0	23.8	29.4									
25.89	6.28	3.26	40.0	0.80	32.0	1.43	0.81	0.10	1.17	1.00	0.12	0.12	1.54	
0.93	1.73	0.00	883.5	24.2	29.8									
25.83	6.28	3.25	40.0	0.80	32.0	1.42	0.81	0.10	1.17	1.00	0.12	0.12	1.54	
0.93	1.76	0.00	884.1	24.5	30.3									
25.78	6.28	3.24	40.0	0.80	32.0	1.42	0.81	0.10	1.17	1.00	0.12	0.12	1.54	
0.93	1.79	0.00	884.7	24.9	30.8									

													Ødetail
25.72	6.28	3.24	40.0	0.80	32.0	1.42	0.81	0.10	1.17	1.00	0.12	0.12	1.53
0.93	1.82	0.00	885.2	25.3	31.2								
25.66	6.28	3.23	40.0	0.80	32.0	1.41	0.81	0.10	1.17	1.00	0.12	0.12	1.53
0.92	1.85	0.00	885.8	25.7	31.7								
25.60	6.28	3.22	40.0	0.80	32.0	1.41	0.81	0.10	1.17	1.00	0.12	0.12	1.53
0.92	1.88	0.00	886.4	26.0	32.1								
25.54	6.28	3.21	40.0	0.80	32.0	1.41	0.80	0.10	1.17	1.00	0.12	0.12	1.52
0.92	1.91	0.00	886.9	26.4	32.6								
25.48	6.28	3.21	40.0	0.80	32.0	1.40	0.80	0.10	1.17	1.00	0.12	0.12	1.52
0.92	1.93	0.00	887.5	26.8	33.0								
25.42	6.28	3.20	40.0	0.80	32.0	1.40	0.80	0.10	1.17	1.00	0.12	0.12	1.52
0.92	1.96	0.00	888.1	27.1	33.5								
25.36	6.28	3.19	40.0	0.80	32.0	1.40	0.80	0.10	1.17	1.00	0.12	0.12	1.51
0.91	1.99	0.00	888.6	27.5	33.9								
25.30	6.28	3.18	40.0	0.80	32.0	1.39	0.80	0.10	1.17	1.00	0.12	0.12	1.51
0.91	2.02	0.00	889.2	27.9	34.4								
25.24	6.28	3.18	40.0	0.80	32.0	1.39	0.79	0.10	1.17	1.00	0.12	0.12	1.51
0.91	2.05	0.00	889.7	28.2	34.8								
25.18	6.28	3.17	40.0	0.80	32.0	1.39	0.79	0.10	1.17	1.00	0.12	0.12	1.50
0.91	2.08	0.00	890.3	28.6	35.3								
25.13	6.28	3.16	40.0	0.80	32.0	1.38	0.79	0.10	1.17	1.00	0.12	0.12	1.50
0.91	2.10	0.00	890.9	29.0	35.7								
25.07	6.28	3.15	40.0	0.80	32.0	1.38	0.79	0.10	1.17	1.00	0.12	0.12	1.50
0.91	2.13	0.00	891.4	29.3	36.2								
25.01	6.28	3.14	40.0	0.80	32.0	1.38	0.79	0.10	1.17	1.00	0.12	0.12	1.49
0.90	2.16	0.00	892.0	29.7	36.6								
24.95	6.28	3.14	40.0	0.80	32.0	1.37	0.78	0.10	1.17	1.00	0.12	0.12	1.49
0.90	2.19	0.00	892.5	30.1	37.1								
24.89	6.28	3.13	40.0	0.80	32.0	1.37	0.78	0.10	1.17	1.00	0.12	0.12	1.49
0.90	2.22	0.00	893.1	30.4	37.5								
24.83	6.28	3.12	40.0	0.80	32.0	1.37	0.78	0.10	1.17	1.00	0.12	0.12	1.48
0.90	2.25	0.00	893.6	30.8	38.0								
24.77	6.28	3.11	40.0	0.80	32.0	1.36	0.78	0.10	1.17	1.00	0.12	0.12	1.48
0.90	2.27	0.00	894.2	31.1	38.4								
24.71	6.28	3.11	40.0	0.80	32.0	1.36	0.78	0.10	1.17	1.00	0.12	0.12	1.48
0.89	2.30	0.00	894.7	31.5	38.8								
24.65	6.28	3.10	40.0	0.80	32.0	1.36	0.77	0.10	1.17	1.00	0.12	0.12	1.47
0.89	2.33	0.00	895.3	31.9	39.3								
24.59	6.28	3.09	40.0	0.80	32.0	1.35	0.77	0.10	1.17	1.00	0.12	0.12	1.47
0.89	2.36	0.00	895.8	32.2	39.7								
24.53	6.28	3.08	40.0	0.80	32.0	1.35	0.77	0.10	1.17	1.00	0.12	0.12	1.47
0.89	2.39	0.00	896.4	32.6	40.1								
24.47	6.28	3.08	40.0	0.80	32.0	1.35	0.77	0.10	1.17	1.00	0.12	0.12	1.46
0.89	2.42	0.00	896.9	32.9	40.6								
24.42	6.28	3.07	40.0	0.80	32.0	1.34	0.77	0.10	1.17	1.00	0.12	0.12	1.46
0.88	2.45	0.00	897.5	33.3	41.0								
24.36	6.28	3.06	40.0	0.80	32.0	1.34	0.76	0.10	1.17	1.00	0.12	0.12	1.46
0.88	2.47	0.00	898.0	33.7	41.5								
24.30	6.28	3.05	40.0	0.80	32.0	1.34	0.76	0.10	1.17	1.00	0.12	0.12	1.45
0.88	2.50	0.00	898.5	34.0	41.9								
24.24	6.28	3.04	40.0	0.80	32.0	1.33	0.76	0.10	1.17	1.00	0.12	0.12	1.45
0.88	2.53	0.00	899.1	34.4	42.3								
24.18	6.28	3.04	40.0	0.80	32.0	1.33	0.76	0.10	1.17	1.00	0.12	0.12	1.45
0.88	2.56	0.00	899.6	34.7	42.8								
24.12	6.28	3.03	40.0	0.80	32.0	1.33	0.76	0.10	1.17	1.00	0.12	0.12	1.44
0.87	2.59	0.00	900.1	35.1	43.2								
24.06	6.28	3.02	40.0	0.80	32.0	1.32	0.76	0.10	1.17	1.00	0.12	0.12	1.44
0.87	2.62	0.00	900.7	35.4	43.6								
24.00	6.28	3.01	40.0	0.80	32.0	1.32	0.75	0.10	1.17	1.00	0.12	0.12	1.44
0.87	2.64	0.00	901.2	35.8	44.0								
23.94	6.28	3.01	40.0	0.80	32.0	1.31	0.75	0.10	1.17	1.00	0.12	0.12	1.43
0.87	2.67	0.00	901.7	36.1	44.5								
23.88	6.28	3.00	40.0	0.80	32.0	1.31	0.75	0.10	1.17	1.00	0.12	0.12	1.43
0.87	2.70	0.00	902.3	36.5	44.9								
23.82	6.28	2.99	40.0	0.80	32.0	1.31	0.75	0.10	1.17	1.00	0.12	0.12	1.43
0.87	2.73	0.00	902.8	36.8	45.3								
23.77	6.28	2.98	40.0	0.80	32.0	1.30	0.75	0.10	1.17	1.00	0.12	0.12	1.42

														Ødetail			
0.86	2.76	0.00	903.3	37.2	45.7												
23.71	6.28	2.98	40.0	0.80	32.0	1.30	0.74	0.10	1.17	1.00	0.12	0.12	1.42				
0.86	2.79	0.00	903.9	37.5	46.2												
23.65	6.28	2.97	40.0	0.80	32.0	1.30	0.74	0.10	1.17	1.00	0.12	0.12	1.42				
0.86	2.82	0.00	904.4	37.9	46.6												
23.59	6.28	2.96	40.0	0.80	32.0	1.29	0.74	0.10	1.17	1.00	0.12	0.12	1.41				
0.86	2.84	0.00	904.9	38.2	47.0												
23.53	6.28	2.95	40.0	0.80	32.0	1.29	0.74	0.10	1.17	1.00	0.12	0.12	1.41				
0.86	2.87	0.00	905.4	38.6	47.4												
23.47	6.28	2.94	40.0	0.80	32.0	1.29	0.74	0.10	1.17	1.00	0.12	0.12	1.41				
0.85	2.90	0.00	906.0	38.9	47.9												
23.41	6.28	2.94	40.0	0.80	32.0	1.28	0.73	0.10	1.17	1.00	0.12	0.12	1.40				
0.85	2.93	0.00	906.5	39.3	48.3												
23.35	6.28	2.93	40.0	0.80	32.0	1.28	0.73	0.10	1.17	1.00	0.12	0.12	1.40				
0.85	2.96	0.00	907.0	39.6	48.7												
23.29	6.28	2.92	40.0	0.80	32.0	1.28	0.73	0.10	1.17	1.00	0.12	0.12	1.40				
0.85	2.99	0.00	907.5	39.9	49.1												
23.23	6.28	2.91	40.0	0.80	32.0	1.27	0.73	0.10	1.17	1.00	0.12	0.12	1.39				
0.85	3.01	0.00	908.0	40.3	49.5												
23.17	6.28	2.91	40.0	0.80	32.0	1.27	0.73	0.10	1.17	1.00	0.12	0.12	1.39				
0.84	3.04	0.00	908.5	40.6	49.9												
23.12	6.28	2.90	40.0	0.80	32.0	1.27	0.72	0.10	1.17	1.00	0.12	0.12	1.39				
0.84	3.07	0.00	909.1	41.0	50.3												
23.06	6.28	2.89	40.0	0.80	32.0	1.26	0.72	0.10	1.17	1.00	0.12	0.12	1.38				
0.84	3.10	0.00	909.6	41.3	50.8												
23.00	6.28	2.88	40.0	0.80	32.0	1.26	0.72	0.10	1.17	1.00	0.12	0.12	1.38				
0.84	3.13	0.00	910.1	41.7	51.2												
22.94	6.28	2.88	40.0	0.80	32.0	1.26	0.72	0.10	1.17	1.00	0.12	0.12	1.38				
0.84	3.16	0.00	910.6	42.0	51.6												
22.88	6.28	2.87	40.0	0.80	32.0	1.25	0.72	0.10	1.17	1.00	0.12	0.12	1.37				
0.83	3.18	0.00	911.1	42.3	52.0												
22.82	6.28	2.86	40.0	0.80	32.0	1.25	0.71	0.10	1.17	1.00	0.12	0.12	1.37				
0.83	3.21	0.00	911.6	42.7	52.4												
22.76	6.28	2.85	40.0	0.80	32.0	1.25	0.71	0.10	1.17	1.00	0.12	0.12	1.37				
0.83	3.24	0.00	912.1	43.0	52.8												
22.70	6.28	2.84	40.0	0.80	32.0	1.24	0.71	0.10	1.17	1.00	0.12	0.12	1.36				
0.83	3.27	0.00	912.6	43.3	53.2												
22.64	6.28	2.84	40.0	0.80	32.0	1.24	0.71	0.10	1.17	1.00	0.12	0.12	1.36				
0.83	3.30	0.00	913.1	43.7	53.6												
22.58	6.28	2.83	40.0	0.80	32.0	1.24	0.71	0.10	1.17	1.00	0.12	0.12	1.36				
0.82	3.33	0.00	913.6	44.0	54.0												
22.52	6.28	2.82	40.0	0.80	32.0	1.23	0.71	0.10	1.17	1.00	0.12	0.12	1.35				
0.82	3.36	0.00	914.1	44.3	54.4												
22.46	6.28	2.81	40.0	0.80	32.0	1.23	0.70	0.10	1.17	1.00	0.12	0.12	1.35				
0.82	3.38	0.00	914.6	44.7	54.8												
22.41	6.28	2.81	40.0	0.80	32.0	1.23	0.70	0.10	1.17	1.00	0.12	0.12	1.35				
0.82	3.41	0.00	915.1	45.0	55.2												
22.35	6.28	2.80	40.0	0.80	32.0	1.22	0.70	0.10	1.17	1.00	0.12	0.12	1.34				
0.82	3.44	0.00	915.6	45.3	55.6												
22.29	6.28	2.79	40.0	0.80	32.0	1.22	0.70	0.10	1.17	1.00	0.12	0.12	1.34				
0.82	3.47	0.00	916.1	45.7	56.0												
22.23	6.28	2.78	40.0	0.80	32.0	1.22	0.70	0.10	1.17	1.00	0.12	0.12	1.33				
0.81	3.50	0.00	916.6	46.0	56.4												
22.17	6.28	2.78	40.0	0.80	32.0	1.21	0.69	0.10	1.17	1.00	0.12	0.12	1.33				
0.81	3.53	0.00	917.1	46.3	56.8												
22.11	6.28	2.77	40.0	0.80	32.0	1.21	0.69	0.10	1.17	1.00	0.12	0.12	1.33				
0.81	3.55	0.00	917.6	46.7	57.2												
22.05	6.28	2.76	40.0	0.80	32.0	1.21	0.69	0.10	1.17	1.00	0.12	0.12	1.32				
0.81	3.58	0.00	918.1	47.0	57.6												
21.99	6.28	2.75	40.0	0.80	32.0	1.20	0.69	0.10	1.17	1.00	0.12	0.12	1.32				
0.81	3.61	0.00	918.6	47.3	58.0												
21.93	6.28	2.75	40.0	0.80	32.0	1.20	0.69	0.10	1.17	1.00	0.12	0.12	1.32				
0.80	3.64	0.00	919.1	47.6	58.4												
21.87	6.28	2.74	40.0	0.80	32.0	1.20	0.68	0.10	1.17	1.00	0.12	0.12	1.31				
0.80	3.67	0.00	919.6	48.0	58.8												
21.81	6.28	2.73	40.0	0.80	32.0	1.19	0.68	0.10	1.17	1.00	0.12	0.12	1.31				
0.80	3.70	0.00	920.1	48.3	59.2												

													Ødetail
21.76	6.28	2.72	40.0	0.80	32.0	1.19	0.68	0.10	1.17	1.00	0.12	0.12	1.31
0.80	3.73	0.00	920.6	48.6	59.6								
21.70	6.28	2.71	40.0	0.80	32.0	1.19	0.68	0.10	1.17	1.00	0.12	0.12	1.30
0.80	3.75	0.00	921.0	48.9	60.0								
21.64	6.28	2.71	40.0	0.80	32.0	1.18	0.68	0.10	1.17	1.00	0.12	0.12	1.30
0.79	3.78	0.00	921.5	49.3	60.4								
21.58	6.28	2.70	40.0	0.80	32.0	1.18	0.67	0.10	1.17	1.00	0.12	0.12	1.30
0.79	3.81	0.00	922.0	49.6	60.8								
21.52	6.28	2.69	40.0	0.80	32.0	1.18	0.67	0.10	1.17	1.00	0.12	0.12	1.29
0.79	3.84	0.00	922.5	49.9	61.1								
21.46	6.28	2.68	40.0	0.80	32.0	1.17	0.67	0.10	1.17	1.00	0.12	0.12	1.29
0.79	3.87	0.00	923.0	50.2	61.5								
21.40	6.28	2.68	40.0	0.80	32.0	1.17	0.67	0.10	1.17	1.00	0.12	0.12	1.29
0.79	3.90	0.00	923.4	50.6	61.9								
21.34	6.28	2.67	40.0	0.80	32.0	1.17	0.67	0.10	1.17	1.00	0.12	0.12	1.28
0.78	3.92	0.00	923.9	50.9	62.3								
21.28	6.28	2.66	40.0	0.80	32.0	1.16	0.66	0.10	1.17	1.00	0.12	0.12	1.28
0.78	3.95	0.00	924.4	51.2	62.7								
21.22	6.28	2.65	40.0	0.80	32.0	1.16	0.66	0.10	1.17	1.00	0.12	0.12	1.28
0.78	3.98	0.00	924.9	51.5	63.1								
21.16	6.28	2.65	40.0	0.80	32.0	1.16	0.66	0.10	1.17	1.00	0.12	0.12	1.27
0.78	4.01	0.00	925.3	51.8	63.4								
21.11	6.28	2.64	40.0	0.80	32.0	1.15	0.66	0.10	1.17	1.00	0.12	0.12	1.27
0.78	4.04	0.00	925.8	52.1	63.8								
21.05	6.28	2.63	40.0	0.80	32.0	1.15	0.66	0.10	1.17	1.00	0.12	0.12	1.27
0.77	4.07	0.00	926.3	52.5	64.2								
20.99	6.28	2.62	40.0	0.80	32.0	1.15	0.66	0.10	1.17	1.00	0.12	0.12	1.26
0.77	4.09	0.00	926.8	52.8	64.6								
20.93	6.28	2.61	40.0	0.80	32.0	1.14	0.65	0.10	1.17	1.00	0.12	0.12	1.26
0.77	4.12	0.00	927.2	53.1	65.0								
20.87	6.28	2.61	40.0	0.80	32.0	1.14	0.65	0.10	1.17	1.00	0.12	0.12	1.26
0.77	4.15	0.00	927.7	53.4	65.3								
20.81	6.28	2.60	40.0	0.80	32.0	1.14	0.65	0.10	1.17	1.00	0.12	0.12	1.25
0.77	4.18	0.00	928.2	53.7	65.7								
20.75	6.28	2.59	40.0	0.80	32.0	1.13	0.65	0.10	1.17	1.00	0.12	0.12	1.25
0.77	4.21	0.00	928.6	54.0	66.1								
20.69	6.28	2.58	40.0	0.80	32.0	1.13	0.65	0.10	1.17	1.00	0.12	0.12	1.25
0.76	4.24	0.00	929.1	54.3	66.5								
20.63	6.28	2.58	40.0	0.80	32.0	1.13	0.64	0.10	1.17	1.00	0.12	0.12	1.24
0.76	4.27	0.00	929.5	54.7	66.8								
20.57	6.28	2.57	40.0	0.80	32.0	1.12	0.64	0.10	1.17	1.00	0.12	0.12	1.24
0.76	4.29	0.00	930.0	55.0	67.2								
20.51	6.28	2.56	40.0	0.80	32.0	1.12	0.64	0.10	1.17	1.00	0.12	0.12	1.24
0.76	4.32	0.00	930.5	55.3	67.6								
20.45	6.28	2.55	40.0	0.80	32.0	1.12	0.64	0.10	1.17	1.00	0.12	0.12	1.23
0.76	4.35	0.00	930.9	55.6	67.9								
20.40	6.28	2.55	40.0	0.80	32.0	1.11	0.64	0.10	1.17	1.00	0.12	0.12	1.23
0.75	4.38	0.00	931.4	55.9	68.3								
20.34	6.28	2.54	40.0	0.80	32.0	1.11	0.63	0.10	1.17	1.00	0.12	0.12	1.23
0.75	4.41	0.00	931.8	56.2	68.7								
20.28	6.28	2.53	40.0	0.80	32.0	1.11	0.63	0.10	1.17	1.00	0.12	0.12	1.22
0.75	4.44	0.00	932.3	56.5	69.1								
20.22	6.28	2.52	40.0	0.80	32.0	1.10	0.63	0.10	1.17	1.00	0.12	0.12	1.22
0.75	4.46	0.00	932.7	56.8	69.4								
20.16	6.28	2.51	40.0	0.80	32.0	1.10	0.63	0.10	1.17	1.00	0.12	0.12	1.22
0.75	4.49	0.00	933.2	57.1	69.8								
20.10	6.28	2.51	40.0	0.80	32.0	1.10	0.63	0.10	1.17	1.00	0.12	0.12	1.21
0.74	4.52	0.00	933.7	57.4	70.1								
20.04	6.28	2.50	40.0	0.80	32.0	1.09	0.62	0.10	1.17	1.00	0.12	0.12	1.21
0.74	4.55	0.00	934.1	57.7	70.5								
19.98	6.28	2.49	40.0	0.80	32.0	1.09	0.62	0.10	1.17	1.00	0.12	0.12	1.21
0.74	4.58	0.00	934.5	58.0	70.9								
19.92	6.28	2.48	40.0	0.80	32.0	1.09	0.62	0.10	1.17	1.00	0.12	0.12	1.20
0.74	4.61	0.00	935.0	58.3	71.2								
19.86	6.28	2.48	40.0	0.80	32.0	1.08	0.62	0.10	1.17	1.00	0.12	0.12	1.20
0.74	4.64	0.00	935.4	58.6	71.6								
19.80	6.28	2.47	40.0	0.80	32.0	1.08	0.62	0.10	1.17	1.00	0.12	0.12	1.20

Ødetail

0.73	4.66	0.00	935.9	58.9	71.9								
19.75	6.28	2.46	40.0	0.80	32.0	1.08	0.62	0.10	1.17	1.00	0.12	0.12	1.19
0.73	4.69	0.00	936.3	59.2	72.3								
19.69	6.28	2.45	40.0	0.80	32.0	1.07	0.61	0.10	1.17	1.00	0.12	0.12	1.19
0.73	4.72	0.00	936.8	59.5	72.7								
19.63	6.28	2.45	40.0	0.80	32.0	1.07	0.61	0.10	1.17	1.00	0.12	0.12	1.19
0.73	4.75	0.00	937.2	59.8	73.0								
19.57	6.28	2.44	40.0	0.80	32.0	1.07	0.61	0.10	1.17	1.00	0.12	0.12	1.18
0.73	4.78	0.00	937.7	60.1	73.4								
19.51	6.28	2.43	40.0	0.80	32.0	1.06	0.61	0.10	1.17	1.00	0.12	0.12	1.18
0.72	4.81	0.00	938.1	60.4	73.7								
19.45	6.28	2.42	40.0	0.80	32.0	1.06	0.61	0.10	1.17	1.00	0.12	0.12	1.18
0.72	4.83	0.00	938.5	60.7	74.1								
19.39	6.28	2.41	40.0	0.80	32.0	1.06	0.60	0.10	1.17	1.00	0.12	0.12	1.17
0.72	4.86	0.00	939.0	61.0	74.4								
19.33	6.28	2.41	40.0	0.80	32.0	1.05	0.60	0.10	1.17	1.00	0.12	0.12	1.17
0.72	4.89	0.00	939.4	61.3	74.8								
19.27	6.28	2.40	40.0	0.80	32.0	1.05	0.60	0.10	1.17	1.00	0.12	0.12	1.17
0.72	4.92	0.00	939.8	61.6	75.1								
19.21	6.28	2.39	40.0	0.80	32.0	1.05	0.60	0.10	1.17	1.00	0.12	0.12	1.16
0.72	4.95	0.00	940.3	61.9	75.5								
19.15	6.28	2.38	40.0	0.80	32.0	1.04	0.60	0.10	1.17	1.00	0.12	0.12	1.16
0.71	4.98	0.00	940.7	62.2	75.8								
19.10	6.28	2.38	40.0	0.80	32.0	1.04	0.59	0.10	1.17	1.00	0.12	0.12	1.16
0.71	5.00	0.00	941.1	62.5	76.2								
19.04	6.28	2.37	40.0	0.80	32.0	1.04	0.59	0.10	1.17	1.00	0.12	0.12	1.15
0.71	5.03	0.00	941.6	62.8	76.5								
18.98	6.28	2.36	40.0	0.80	32.0	1.03	0.59	0.10	1.17	1.00	0.12	0.12	1.15
0.71	5.06	0.00	942.0	63.1	76.9								
18.92	6.28	2.35	40.0	0.80	32.0	1.03	0.59	0.10	1.17	1.00	0.12	0.12	1.15
0.71	5.09	0.00	942.4	63.4	77.2								
18.86	6.28	2.35	40.0	0.80	32.0	1.03	0.59	0.10	1.17	1.00	0.12	0.12	1.14
0.70	5.12	0.00	942.8	63.7	77.6								
18.80	6.28	2.34	40.0	0.80	32.0	1.02	0.58	0.10	1.17	1.00	0.12	0.12	1.14
0.70	5.15	0.00	943.3	64.0	77.9								
18.74	6.28	2.33	40.0	0.80	32.0	1.02	0.58	0.10	1.17	1.00	0.12	0.12	1.14
0.70	5.18	0.00	943.7	64.2	78.2								
18.68	6.28	2.32	40.0	0.80	32.0	1.02	0.58	0.10	1.17	1.00	0.12	0.12	1.13
0.70	5.20	0.00	944.1	64.5	78.6								
18.62	6.28	2.31	40.0	0.80	32.0	1.01	0.58	0.10	1.17	1.00	0.12	0.12	1.13
0.70	5.23	0.00	944.5	64.8	78.9								
18.56	6.28	2.31	40.0	0.80	32.0	1.01	0.58	0.10	1.17	1.00	0.12	0.12	1.13
0.69	5.26	0.00	944.9	65.1	79.3								
18.50	6.28	2.30	40.0	0.80	32.0	1.01	0.57	0.10	1.17	1.00	0.12	0.12	1.12
0.69	5.29	0.00	945.4	65.4	79.6								
18.44	6.28	2.29	40.0	0.80	32.0	1.00	0.57	0.10	1.17	1.00	0.12	0.12	1.12
0.69	5.32	0.00	945.8	65.7	79.9								
18.39	6.28	2.28	40.0	0.80	32.0	1.00	0.57	0.10	1.17	1.00	0.12	0.12	1.12
0.69	5.35	0.00	946.2	66.0	80.3								
18.33	6.28	2.28	40.0	0.80	32.0	1.00	0.57	0.10	1.17	1.00	0.12	0.12	1.11
0.69	5.37	0.00	946.6	66.2	80.6								
18.27	6.28	2.27	40.0	0.80	32.0	0.99	0.57	0.10	1.17	1.00	0.12	0.12	1.11
0.68	5.40	0.00	947.0	66.5	80.9								
18.21	6.28	2.26	40.0	0.80	32.0	0.99	0.57	0.10	1.17	1.00	0.12	0.12	1.11
0.68	5.43	0.00	947.4	66.8	81.3								
18.15	6.28	2.25	40.0	0.80	32.0	0.99	0.56	0.10	1.17	1.00	0.12	0.12	1.10
0.68	5.46	0.00	947.8	67.1	81.6								
18.09	6.28	2.25	40.0	0.80	32.0	0.98	0.56	0.10	1.17	1.00	0.12	0.12	1.10
0.68	5.49	0.00	948.2	67.4	81.9								
18.03	6.28	2.24	40.0	0.80	32.0	0.98	0.56	0.10	1.17	1.00	0.12	0.12	1.10
0.68	5.52	0.00	948.6	67.6	82.3								
17.97	6.28	2.23	40.0	0.80	32.0	0.98	0.56	0.10	1.17	1.00	0.12	0.12	1.09
0.67	5.54	0.00	949.1	67.9	82.6								
17.91	6.28	2.22	40.0	0.80	32.0	0.97	0.56	0.10	1.17	1.00	0.12	0.12	1.09
0.67	5.57	0.00	949.5	68.2	82.9								
17.85	6.28	2.21	40.0	0.80	32.0	0.97	0.55	0.10	1.17	1.00	0.12	0.12	1.09
0.67	5.60	0.00	949.9	68.5	83.2								

													Ødetail
17.79	6.28	2.21	40.0	0.80	32.0	0.97	0.55	0.10	1.17	1.00	0.12	0.12	1.08
0.67	5.63	0.00	950.3	68.8	83.6								
17.74	6.28	2.20	40.0	0.80	32.0	0.96	0.55	0.10	1.17	1.00	0.12	0.12	1.08
0.67	5.66	0.00	950.7	69.0	83.9								
17.68	6.28	2.19	40.0	0.80	32.0	0.96	0.55	0.10	1.17	1.00	0.12	0.12	1.08
0.67	5.69	0.00	951.1	69.3	84.2								
17.62	6.28	2.18	40.0	0.80	32.0	0.96	0.55	0.10	1.17	1.00	0.12	0.12	1.07
0.66	5.72	0.00	951.5	69.6	84.5								
17.56	6.28	2.18	40.0	0.80	32.0	0.95	0.54	0.10	1.17	1.00	0.12	0.12	1.07
0.66	5.74	0.00	951.9	69.9	84.9								
17.50	6.28	2.17	40.0	0.80	32.0	0.95	0.54	0.10	1.17	1.00	0.12	0.12	1.07
0.66	5.77	0.00	952.3	70.1	85.2								
17.44	6.28	2.16	40.0	0.80	32.0	0.95	0.54	0.10	1.17	1.00	0.12	0.12	1.06
0.66	5.80	0.00	952.7	70.4	85.5								
17.38	6.28	2.15	40.0	0.80	32.0	0.94	0.54	0.10	1.17	1.00	0.12	0.12	1.06
0.66	5.83	0.00	953.0	70.7	85.8								
17.32	6.28	2.15	40.0	0.80	32.0	0.94	0.54	0.10	1.17	1.00	0.12	0.12	1.06
0.65	5.86	0.00	953.4	70.9	86.1								
17.26	6.28	2.14	40.0	0.80	32.0	0.94	0.53	0.10	1.17	1.00	0.12	0.12	1.05
0.65	5.89	0.00	953.8	71.2	86.4								
17.20	6.28	2.13	40.0	0.80	32.0	0.93	0.53	0.10	1.17	1.00	0.12	0.12	1.05
0.65	5.91	0.00	954.2	71.5	86.8								
17.14	6.28	2.12	40.0	0.80	32.0	0.93	0.53	0.10	1.17	1.00	0.12	0.12	1.05
0.65	5.94	0.00	954.6	71.8	87.1								
17.09	6.28	2.11	40.0	0.80	32.0	0.93	0.53	0.10	1.17	1.00	0.12	0.12	1.04
0.65	5.97	0.00	955.0	72.0	87.4								
17.03	6.28	2.11	40.0	0.80	32.0	0.92	0.53	0.10	1.17	1.00	0.12	0.12	1.04
0.64	6.00	0.00	955.4	72.3	87.7								
16.97	6.28	2.10	40.0	0.80	32.0	0.92	0.52	0.10	1.17	1.00	0.12	0.12	1.04
0.64	6.03	0.00	955.8	72.6	88.0								
16.91	6.28	2.09	40.0	0.80	32.0	0.91	0.52	0.10	1.17	1.00	0.12	0.12	1.03
0.64	6.06	0.00	956.1	72.8	88.3								
16.85	6.28	2.08	40.0	0.80	32.0	0.91	0.52	0.10	1.17	1.00	0.12	0.12	1.03
0.64	6.09	0.00	956.5	73.1	88.6								
16.79	6.28	2.08	40.0	0.80	32.0	0.91	0.52	0.10	1.17	1.00	0.12	0.12	1.03
0.64	6.11	0.00	956.9	73.4	88.9								
16.73	6.28	2.07	40.0	0.80	32.0	0.90	0.52	0.10	1.17	1.00	0.12	0.12	1.02
0.63	6.14	0.00	957.3	73.6	89.3								
16.67	6.28	2.06	40.0	0.80	32.0	0.90	0.52	0.10	1.17	1.00	0.12	0.12	1.02
0.63	6.17	0.00	957.7	73.9	89.6								
16.61	6.28	2.05	40.0	0.80	32.0	0.90	0.51	0.10	1.17	1.00	0.12	0.12	1.02
0.63	6.20	0.00	958.0	74.1	89.9								
16.55	6.28	2.05	40.0	0.80	32.0	0.89	0.51	0.10	1.17	1.00	0.12	0.12	1.01
0.63	6.23	0.00	958.4	74.4	90.2								
16.49	6.28	2.04	40.0	0.80	32.0	0.89	0.51	0.10	1.17	1.00	0.12	0.12	1.01
0.63	6.26	0.00	958.8	74.7	90.5								
16.43	6.28	2.03	40.0	0.80	32.0	0.89	0.51	0.10	1.17	1.00	0.12	0.12	1.01
0.62	6.28	0.00	959.2	74.9	90.8								
16.38	6.28	2.02	40.0	0.80	32.0	0.88	0.51	0.10	1.17	1.00	0.12	0.12	1.00
0.62	6.31	0.00	959.5	75.2	91.1								
16.32	6.28	2.01	40.0	0.80	32.0	0.88	0.50	0.10	1.17	1.00	0.12	0.12	1.00
0.62	6.34	0.00	959.9	75.5	91.4								
16.26	6.28	2.01	40.0	0.80	32.0	0.88	0.50	0.10	1.17	1.00	0.12	0.12	1.00
0.62	6.37	0.00	960.3	75.7	91.7								
16.20	6.28	2.00	40.0	0.80	32.0	0.87	0.50	0.10	1.17	1.00	0.12	0.12	0.99
0.62	6.40	0.00	960.7	76.0	92.0								
16.14	6.28	1.99	40.0	0.80	32.0	0.87	0.50	0.10	1.17	1.00	0.12	0.12	0.99
0.62	6.43	0.00	961.0	76.2	92.3								
16.08	6.28	1.98	40.0	0.80	32.0	0.87	0.50	0.10	1.17	1.00	0.12	0.12	0.99
0.61	6.45	0.00	961.4	76.5	92.6								
16.02	6.28	1.98	40.0	0.80	32.0	0.86	0.49	0.10	1.17	1.00	0.12	0.12	0.98
0.61	6.48	0.00	961.7	76.7	92.9								
15.96	6.28	1.97	30.0	0.80	24.0	0.61	0.35	0.10	1.17	1.00	0.12	0.12	0.73
0.47	6.51	0.00	962.0	76.9	93.1								
15.90	6.28	1.96	30.0	0.80	24.0	0.61	0.35	0.10	1.17	1.00	0.12	0.12	0.73
0.47	6.54	0.00	962.3	77.1	93.3								
15.84	6.28	1.96	30.0	0.80	24.0	0.61	0.35	0.10	1.17	1.00	0.12	0.12	0.73

Ødetail

0.47	6.57	0.00	962.6	77.3	93.5								
15.78	6.28	1.95	30.0	0.80	24.0	0.61	0.35	0.10	1.17	1.00	0.12	0.12	0.72
0.46	6.60	0.00	962.8	77.5	93.8								
15.73	6.28	1.94	30.0	0.80	24.0	0.60	0.35	0.10	1.17	1.00	0.12	0.12	0.72
0.46	6.63	0.00	963.1	77.7	94.0								
15.67	6.28	1.93	30.0	0.80	24.0	0.60	0.34	0.10	1.17	1.00	0.12	0.12	0.72
0.46	6.65	0.00	963.4	77.9	94.2								
15.61	6.28	1.93	30.0	0.80	24.0	0.60	0.34	0.10	1.17	1.00	0.12	0.12	0.72
0.46	6.68	0.00	963.6	78.1	94.4								
15.55	6.28	1.92	30.0	0.80	24.0	0.60	0.34	0.10	1.17	1.00	0.12	0.12	0.72
0.46	6.71	0.00	963.9	78.3	94.6								
15.49	6.28	1.91	30.0	0.80	24.0	0.60	0.34	0.10	1.17	1.00	0.12	0.12	0.71
0.46	6.74	0.00	964.2	78.5	94.9								
15.43	6.28	1.91	30.0	0.80	24.0	0.59	0.34	0.10	1.17	1.00	0.12	0.12	0.71
0.46	6.77	0.00	964.4	78.7	95.1								
15.37	6.28	1.90	30.0	0.80	24.0	0.59	0.34	0.10	1.17	1.00	0.12	0.12	0.71
0.46	6.80	0.00	964.7	78.9	95.3								
15.31	6.28	1.89	30.0	0.80	24.0	0.59	0.34	0.10	1.17	1.00	0.12	0.12	0.71
0.45	6.82	0.00	965.0	79.1	95.5								
15.25	6.28	1.88	30.0	0.80	24.0	0.59	0.34	0.10	1.17	1.00	0.12	0.12	0.70
0.45	6.85	0.00	965.2	79.3	95.7								
15.19	6.28	1.88	30.0	0.80	24.0	0.59	0.33	0.10	1.17	1.00	0.12	0.12	0.70
0.45	6.88	0.00	965.5	79.5	95.9								
15.13	6.28	1.87	30.0	0.80	24.0	0.58	0.33	0.10	1.17	1.00	0.12	0.12	0.70
0.45	6.91	0.00	965.7	79.7	96.1								
15.08	6.28	1.86	30.0	0.80	24.0	0.58	0.33	0.10	1.17	1.00	0.12	0.12	0.70
0.45	6.94	0.00	966.0	79.9	96.4								
15.02	6.28	1.86	30.0	0.80	24.0	0.58	0.33	0.10	1.17	1.00	0.12	0.12	0.70
0.45	6.97	0.00	966.3	80.1	96.6								
14.96	6.28	1.85	30.0	0.80	24.0	0.58	0.33	0.10	1.17	1.00	0.12	0.12	0.69
0.45	7.00	0.00	966.5	80.3	96.8								
14.90	6.28	1.84	30.0	0.80	24.0	0.57	0.33	0.10	1.17	1.00	0.12	0.12	0.69
0.45	7.02	0.00	966.8	80.5	97.0								
14.84	6.28	1.83	30.0	0.80	24.0	0.57	0.33	0.10	1.17	1.00	0.12	0.12	0.69
0.44	7.05	0.00	967.0	80.7	97.2								
14.78	6.28	1.83	30.0	0.80	24.0	0.57	0.33	0.10	1.17	1.00	0.12	0.12	0.69
0.44	7.08	0.00	967.3	80.9	97.4								
14.72	6.28	1.82	30.0	0.80	24.0	0.57	0.32	0.10	1.17	1.00	0.12	0.12	0.68
0.44	7.11	0.00	967.5	81.1	97.6								
14.66	6.28	1.81	30.0	0.80	24.0	0.57	0.32	0.10	1.17	1.00	0.12	0.12	0.68
0.44	7.14	0.00	967.8	81.3	97.8								
14.60	6.28	1.81	30.0	0.80	24.0	0.56	0.32	0.10	1.17	1.00	0.12	0.12	0.68
0.44	7.17	0.00	968.0	81.5	98.0								
14.54	6.28	1.80	30.0	0.80	24.0	0.56	0.32	0.10	1.17	1.00	0.12	0.12	0.68
0.44	7.19	0.00	968.3	81.7	98.2								
14.48	6.28	1.79	30.0	0.80	24.0	0.56	0.32	0.10	1.17	1.00	0.12	0.12	0.68
0.44	7.22	0.00	968.5	81.8	98.5								
14.42	6.28	1.78	30.0	0.80	24.0	0.56	0.32	0.10	1.17	1.00	0.12	0.12	0.67
0.44	7.25	0.00	968.8	82.0	98.7								
14.37	6.28	1.78	30.0	0.80	24.0	0.55	0.32	0.10	1.17	1.00	0.12	0.12	0.67
0.43	7.28	0.00	969.0	82.2	98.9								
14.31	6.28	1.77	30.0	0.80	24.0	0.55	0.32	0.10	1.17	1.00	0.12	0.12	0.67
0.43	7.31	0.00	969.3	82.4	99.1								
14.25	6.28	1.76	30.0	0.80	24.0	0.55	0.31	0.10	1.17	1.00	0.12	0.12	0.67
0.43	7.34	0.00	969.5	82.6	99.3								
14.19	6.28	1.76	30.0	0.80	24.0	0.55	0.31	0.10	1.17	1.00	0.12	0.12	0.66
0.43	7.36	0.00	969.8	82.8	99.5								
14.13	6.28	1.75	30.0	0.80	24.0	0.55	0.31	0.10	1.17	1.00	0.12	0.12	0.66
0.43	7.39	0.00	970.0	83.0	99.7								
14.07	6.28	1.74	30.0	0.80	24.0	0.54	0.31	0.10	1.17	1.00	0.12	0.12	0.66
0.43	7.42	0.00	970.3	83.2	99.9								
14.01	6.28	1.74	30.0	0.80	24.0	0.54	0.31	0.10	1.17	1.00	0.12	0.12	0.66
0.43	7.45	0.00	970.5	83.4	100.1								
13.95	6.28	1.73	30.0	0.80	24.0	0.54	0.31	0.10	1.17	1.00	0.12	0.12	0.66
0.43	7.48	0.00	970.8	83.5	100.3								
13.89	6.28	1.72	30.0	0.80	24.0	0.54	0.31	0.10	1.17	1.00	0.12	0.12	0.65
0.42	7.51	0.00	971.0	83.7	100.5								

							0detail						
13.83	6.28	1.71	30.0	0.80	24.0	0.53	0.31	0.10	1.17	1.00	0.12	0.12	0.65
0.42	7.54	0.00	971.3	83.9	100.7								
13.77	6.28	1.71	30.0	0.80	24.0	0.53	0.30	0.10	1.17	1.00	0.12	0.12	0.65
0.42	7.56	0.00	971.5	84.1	100.9								
13.72	6.28	1.70	30.0	0.80	24.0	0.53	0.30	0.10	1.17	1.00	0.12	0.12	0.65
0.42	7.59	0.00	971.7	84.3	101.1								
13.66	6.28	1.69	30.0	0.80	24.0	0.53	0.30	0.10	1.17	1.00	0.12	0.12	0.64
0.42	7.62	0.00	972.0	84.5	101.3								
13.60	6.28	1.69	30.0	0.80	24.0	0.53	0.30	0.10	1.17	1.00	0.12	0.12	0.64
0.42	7.65	0.00	972.2	84.6	101.5								
13.54	6.28	1.68	30.0	0.80	24.0	0.52	0.30	0.10	1.17	1.00	0.12	0.12	0.64
0.42	7.68	0.00	972.5	84.8	101.7								
13.48	6.28	1.67	30.0	0.80	24.0	0.52	0.30	0.10	1.17	1.00	0.12	0.12	0.64
0.42	7.71	0.00	972.7	85.0	101.9								
13.42	6.28	1.66	30.0	0.80	24.0	0.52	0.30	0.10	1.17	1.00	0.12	0.12	0.64
0.41	7.73	0.00	972.9	85.2	102.1								
13.36	6.28	1.66	30.0	0.80	24.0	0.52	0.30	0.10	1.17	1.00	0.12	0.12	0.63
0.41	7.76	0.00	973.2	85.4	102.3								
13.30	6.28	1.65	30.0	0.80	24.0	0.51	0.29	0.10	1.17	1.00	0.12	0.12	0.63
0.41	7.79	0.00	973.4	85.6	102.4								
13.24	6.28	1.64	30.0	0.80	24.0	0.51	0.29	0.10	1.17	1.00	0.12	0.12	0.63
0.41	7.82	0.00	973.6	85.7	102.6								
13.18	6.28	1.64	30.0	0.80	24.0	0.51	0.29	0.10	1.17	1.00	0.12	0.12	0.63
0.41	7.85	0.00	973.9	85.9	102.8								
13.12	6.28	1.63	30.0	0.80	24.0	0.51	0.29	0.10	1.17	1.00	0.12	0.12	0.63
0.41	7.88	0.00	974.1	86.1	103.0								
13.07	6.28	1.62	30.0	0.80	24.0	0.51	0.29	0.10	1.17	1.00	0.12	0.12	0.62
0.41	7.91	0.00	974.3	86.3	103.2								
13.01	6.28	1.61	30.0	0.80	24.0	0.50	0.29	0.10	1.17	1.00	0.12	0.12	0.62
0.41	7.93	0.00	974.6	86.5	103.4								
12.95	6.28	1.61	30.0	0.80	24.0	0.50	0.29	0.10	1.17	1.00	0.12	0.12	0.62
0.40	7.96	0.00	974.8	86.6	103.6								
12.89	6.28	1.60	30.0	0.80	24.0	0.50	0.29	0.10	1.17	1.00	0.12	0.12	0.62
0.40	7.99	0.00	975.0	86.8	103.8								
12.83	6.28	1.59	30.0	0.80	24.0	0.50	0.28	0.10	1.17	1.00	0.12	0.12	0.61
0.40	8.02	0.00	975.2	87.0	104.0								
12.77	6.28	1.59	30.0	0.80	24.0	0.49	0.28	0.10	1.17	1.00	0.12	0.12	0.61
0.40	8.05	0.00	975.5	87.2	104.2								
12.71	6.28	1.58	30.0	0.80	24.0	0.49	0.28	0.10	1.17	1.00	0.12	0.12	0.61
0.40	8.08	0.00	975.7	87.3	104.3								
12.65	6.28	1.57	30.0	0.80	24.0	0.49	0.28	0.10	1.17	1.00	0.12	0.12	0.61
0.40	8.10	0.00	975.9	87.5	104.5								
12.59	6.28	1.57	30.0	0.80	24.0	0.49	0.28	0.10	1.17	1.00	0.12	0.12	0.61
0.40	8.13	0.00	976.1	87.7	104.7								
12.53	6.28	1.56	30.0	0.80	24.0	0.49	0.28	0.10	1.17	1.00	0.12	0.12	0.60
0.39	8.16	0.00	976.4	87.9	104.9								
12.47	6.28	1.55	30.0	0.80	24.0	0.48	0.28	0.10	1.17	1.00	0.12	0.12	0.60
0.39	8.19	0.00	976.6	88.0	105.1								
12.41	6.28	1.54	30.0	0.80	24.0	0.48	0.27	0.10	1.17	1.00	0.12	0.12	0.60
0.39	8.22	0.00	976.8	88.2	105.3								
12.36	6.28	1.54	30.0	0.80	24.0	0.48	0.27	0.10	1.17	1.00	0.12	0.12	0.60
0.39	8.25	0.00	977.0	88.4	105.5								
12.30	6.28	1.53	30.0	0.80	24.0	0.48	0.27	0.10	1.17	1.00	0.12	0.12	0.59
0.39	8.27	0.00	977.3	88.6	105.6								
12.24	6.28	1.52	30.0	0.80	24.0	0.47	0.27	0.10	1.17	1.00	0.12	0.12	0.59
0.39	8.30	0.00	977.5	88.7	105.8								
12.18	6.28	1.52	30.0	0.80	24.0	0.47	0.27	0.10	1.17	1.00	0.12	0.12	0.59
0.39	8.33	0.00	977.7	88.9	106.0								
12.12	6.28	1.51	30.0	0.80	24.0	0.47	0.27	0.10	1.17	1.00	0.12	0.12	0.59
0.39	8.36	0.00	977.9	89.1	106.2								
12.06	6.28	1.50	30.0	0.80	24.0	0.47	0.27	0.10	1.17	1.00	0.12	0.12	0.59
0.38	8.39	0.00	978.1	89.3	106.4								
12.00	6.28	1.49	30.0	0.80	24.0	0.47	0.27	0.10	1.17	1.00	0.12	0.12	0.58
0.38	8.42	0.00	978.3	89.4	106.5								
11.94	6.28	1.49	30.0	0.80	24.0	0.46	0.26	0.10	1.17	1.00	0.12	0.12	0.58
0.38	8.45	0.00	978.6	89.6	106.7								
11.88	6.28	1.48	30.0	0.80	24.0	0.46	0.26	0.10	1.17	1.00	0.12	0.12	0.58

Ødetail

0.38	8.47	0.00	978.8	89.8	106.9								
11.82	6.28	1.47	30.0	0.80	24.0	0.46	0.26	0.10	1.17	1.00	0.12	0.12	0.58
0.38	8.50	0.00	979.0	89.9	107.1								
11.76	6.28	1.47	30.0	0.80	24.0	0.46	0.26	0.10	1.17	1.00	0.12	0.12	0.57
0.38	8.53	0.00	979.2	90.1	107.3								
11.71	6.28	1.46	30.0	0.80	24.0	0.45	0.26	0.10	1.17	1.00	0.12	0.12	0.57
0.38	8.56	0.00	979.4	90.3	107.4								
11.65	6.28	1.45	30.0	0.80	24.0	0.45	0.26	0.10	1.17	1.00	0.12	0.12	0.57
0.38	8.59	0.00	979.6	90.4	107.6								
11.59	6.28	1.44	30.0	0.80	24.0	0.45	0.26	0.10	1.17	1.00	0.12	0.12	0.57
0.37	8.62	0.00	979.8	90.6	107.8								
11.53	6.28	1.44	30.0	0.80	24.0	0.45	0.26	0.10	1.17	1.00	0.12	0.12	0.57
0.37	8.64	0.00	980.1	90.8	108.0								
11.47	6.28	1.43	30.0	0.80	24.0	0.45	0.25	0.10	1.17	1.00	0.12	0.12	0.56
0.37	8.67	0.00	980.3	90.9	108.1								
11.41	6.28	1.42	30.0	0.80	24.0	0.44	0.25	0.10	1.17	1.00	0.12	0.12	0.56
0.37	8.70	0.00	980.5	91.1	108.3								
11.35	6.28	1.42	30.0	0.80	24.0	0.44	0.25	0.10	1.17	1.00	0.12	0.12	0.56
0.37	8.73	0.00	980.7	91.3	108.5								
11.29	6.28	1.41	30.0	0.80	24.0	0.44	0.25	0.10	1.17	1.00	0.12	0.12	0.56
0.37	8.76	0.00	980.9	91.4	108.7								
11.23	6.28	1.40	30.0	0.80	24.0	0.44	0.25	0.10	1.17	1.00	0.12	0.12	0.55
0.37	8.79	0.00	981.1	91.6	108.8								
11.17	6.28	1.39	30.0	0.80	24.0	0.43	0.25	0.10	1.17	1.00	0.12	0.12	0.55
0.37	8.82	0.00	981.3	91.8	109.0								
11.11	6.28	1.39	30.0	0.80	24.0	0.43	0.25	0.10	1.17	1.00	0.12	0.12	0.55
0.36	8.84	0.00	981.5	91.9	109.2								
11.06	6.28	1.38	30.0	0.80	24.0	0.43	0.25	0.10	1.17	1.00	0.12	0.12	0.55
0.36	8.87	0.00	981.7	92.1	109.3								
11.00	6.28	1.37	30.0	0.80	24.0	0.43	0.24	0.10	1.17	1.00	0.12	0.12	0.55
0.36	8.90	0.00	981.9	92.3	109.5								
10.94	6.28	1.37	30.0	0.80	24.0	0.43	0.24	0.10	1.17	1.00	0.12	0.12	0.54
0.36	8.93	0.00	982.1	92.4	109.7								
10.88	6.28	1.36	30.0	0.80	24.0	0.42	0.24	0.10	1.17	1.00	0.12	0.12	0.54
0.36	8.96	0.00	982.3	92.6	109.8								
10.82	6.28	1.35	30.0	0.80	24.0	0.42	0.24	0.10	1.17	1.00	0.12	0.12	0.54
0.36	8.99	0.00	982.5	92.7	110.0								
10.76	6.28	1.35	30.0	0.80	24.0	0.42	0.24	0.10	1.17	1.00	0.12	0.12	0.54
0.36	9.01	0.00	982.7	92.9	110.2								
10.70	6.28	1.34	30.0	0.80	24.0	0.42	0.24	0.10	1.17	1.00	0.12	0.12	0.53
0.36	9.04	0.00	982.9	93.1	110.3								
10.64	6.28	1.33	30.0	0.80	24.0	0.41	0.24	0.10	1.17	1.00	0.12	0.12	0.53
0.35	9.07	0.00	983.1	93.2	110.5								
10.58	6.28	1.32	30.0	0.80	24.0	0.41	0.24	0.10	1.17	1.00	0.12	0.12	0.53
0.35	9.10	0.00	983.3	93.4	110.7								
10.52	6.28	1.32	30.0	0.80	24.0	0.41	0.23	0.10	1.17	1.00	0.12	0.12	0.53
0.35	9.13	0.00	983.5	93.5	110.8								
10.46	6.28	1.31	30.0	0.80	24.0	0.41	0.23	0.10	1.17	1.00	0.12	0.12	0.53
0.35	9.16	0.00	983.7	93.7	111.0								
10.40	6.28	1.30	30.0	0.80	24.0	0.41	0.23	0.10	1.17	1.00	0.12	0.12	0.52
0.35	9.18	0.00	983.9	93.9	111.2								
10.35	6.28	1.30	30.0	0.80	24.0	0.40	0.23	0.10	1.17	1.00	0.12	0.12	0.52
0.35	9.21	0.00	984.1	94.0	111.3								
10.29	6.28	1.29	30.0	0.80	24.0	0.40	0.23	0.10	1.17	1.00	0.12	0.12	0.52
0.35	9.24	0.00	984.3	94.2	111.5								
10.23	6.28	1.28	30.0	0.80	24.0	0.40	0.23	0.10	1.17	1.00	0.12	0.12	0.52
0.35	9.27	0.00	984.5	94.3	111.6								
10.17	6.28	1.27	30.0	0.80	24.0	0.40	0.23	0.10	1.17	1.00	0.12	0.12	0.51
0.34	9.30	0.00	984.7	94.5	111.8								
10.11	6.28	1.27	30.0	0.80	24.0	0.39	0.23	0.10	1.17	1.00	0.12	0.12	0.51
0.34	9.33	0.00	984.8	94.6	112.0								
10.05	6.28	1.26	30.0	0.80	24.0	0.39	0.22	0.10	1.17	1.00	0.12	0.12	0.51
0.34	9.36	0.00	985.0	94.8	112.1								
9.99	6.28	1.25	37.0	0.80	29.6	0.50	0.28	0.75	0.82	1.00	0.62	0.62	1.12
0.90	9.38	0.00	985.5	95.2	112.5								
9.93	6.28	1.25	37.0	0.80	29.6	0.50	0.28	0.75	0.82	1.00	0.62	0.62	1.11
0.90	9.41	0.00	985.9	95.5	112.9								

							Ødetail						
9.87	6.28	1.24	37.0	0.80	29.6	0.49	0.28	0.75	0.82	1.00	0.62	0.62	1.11
0.90	9.44	0.00	986.3	95.9	113.2								
9.81	6.28	1.23	37.0	0.80	29.6	0.49	0.28	0.75	0.82	1.00	0.62	0.62	1.11
0.90	9.47	0.00	986.7	96.3	113.6								
9.75	6.28	1.22	37.0	0.80	29.6	0.49	0.28	0.75	0.82	1.00	0.62	0.62	1.10
0.90	9.50	0.00	987.1	96.6	114.0								
9.70	6.28	1.22	37.0	0.80	29.6	0.48	0.28	0.75	0.82	1.00	0.62	0.62	1.10
0.89	9.53	0.00	987.5	97.0	114.3								
9.64	6.28	1.21	37.0	0.80	29.6	0.48	0.27	0.75	0.82	1.00	0.62	0.62	1.10
0.89	9.55	0.00	987.9	97.3	114.7								
9.58	6.28	1.20	37.0	0.80	29.6	0.48	0.27	0.75	0.82	1.00	0.62	0.62	1.10
0.89	9.58	0.00	988.3	97.7	115.1								
9.52	6.28	1.19	37.0	0.80	29.6	0.47	0.27	0.75	0.82	1.00	0.62	0.62	1.09
0.89	9.61	0.00	988.7	98.1	115.5								
9.46	6.28	1.19	37.0	0.80	29.6	0.47	0.27	0.75	0.82	1.00	0.62	0.62	1.09
0.89	9.64	0.00	989.1	98.4	115.8								
9.40	6.28	1.18	37.0	0.80	29.6	0.47	0.27	0.75	0.82	1.00	0.62	0.62	1.09
0.89	9.67	0.00	989.5	98.8	116.2								
9.34	6.28	1.17	37.0	0.80	29.6	0.47	0.27	0.75	0.82	1.00	0.62	0.62	1.08
0.88	9.70	0.00	989.9	99.1	116.6								
9.28	6.28	1.16	37.0	0.80	29.6	0.46	0.26	0.75	0.82	1.00	0.62	0.62	1.08
0.88	9.73	0.00	990.3	99.5	116.9								
9.22	6.28	1.16	37.0	0.80	29.6	0.46	0.26	0.75	0.82	1.00	0.62	0.62	1.08
0.88	9.75	0.00	990.7	99.8	117.3								
9.16	6.28	1.15	37.0	0.80	29.6	0.46	0.26	0.75	0.82	1.00	0.62	0.62	1.08
0.88	9.78	0.00	991.1	100.2	117.6								
9.10	6.28	1.14	37.0	0.80	29.6	0.45	0.26	0.75	0.82	1.00	0.62	0.62	1.07
0.88	9.81	0.00	991.5	100.5	118.0								
9.05	6.28	1.13	37.0	0.80	29.6	0.45	0.26	0.75	0.82	1.00	0.62	0.62	1.07
0.88	9.84	0.00	991.9	100.9	118.4								
8.99	6.28	1.13	37.0	0.80	29.6	0.45	0.26	0.75	0.82	1.00	0.62	0.62	1.07
0.87	9.87	0.00	992.3	101.3	118.7								
8.93	6.28	1.12	37.0	0.80	29.6	0.45	0.25	0.75	0.82	1.00	0.62	0.62	1.06
0.87	9.90	0.00	992.7	101.6	119.1								
8.87	6.28	1.11	37.0	0.80	29.6	0.44	0.25	0.75	0.82	1.00	0.62	0.62	1.06
0.87	9.92	0.00	993.1	102.0	119.4								
8.81	6.28	1.10	37.0	0.80	29.6	0.44	0.25	0.75	0.82	1.00	0.62	0.62	1.06
0.87	9.95	0.00	993.5	102.3	119.8								
8.75	6.28	1.10	37.0	0.80	29.6	0.44	0.25	0.75	0.82	1.00	0.62	0.62	1.05
0.87	9.98	0.00	993.9	102.7	120.2								
8.69	6.28	1.09	37.0	0.80	29.6	0.43	0.25	0.75	0.82	1.00	0.62	0.62	1.05
0.87	10.01	0.00	994.3	103.0	120.5								
8.63	6.28	1.08	37.0	0.80	29.6	0.43	0.25	0.75	0.82	1.00	0.62	0.62	1.05
0.86	10.04	0.00	994.7	103.4	120.9								
8.57	6.28	1.08	37.0	0.80	29.6	0.43	0.24	0.75	0.82	1.00	0.62	0.62	1.05
0.86	10.07	0.00	995.1	103.7	121.2								
8.51	6.28	1.07	37.0	0.80	29.6	0.42	0.24	0.75	0.82	1.00	0.62	0.62	1.04
0.86	10.09	0.00	995.5	104.1	121.6								
8.45	6.28	1.06	37.0	0.80	29.6	0.42	0.24	0.75	0.82	1.00	0.62	0.62	1.04
0.86	10.12	0.00	995.9	104.4	121.9								
8.39	6.28	1.05	37.0	0.80	29.6	0.42	0.24	0.75	0.82	1.00	0.62	0.62	1.04
0.86	10.15	0.00	996.2	104.8	122.3								
8.34	6.28	1.05	37.0	0.80	29.6	0.42	0.24	0.75	0.82	1.00	0.62	0.62	1.03
0.86	10.18	0.00	996.6	105.1	122.6								
8.28	6.28	1.04	37.0	0.80	29.6	0.41	0.24	0.75	0.82	1.00	0.62	0.62	1.03
0.85	10.21	0.00	997.0	105.4	123.0								
8.22	6.28	1.03	37.0	0.80	29.6	0.41	0.23	0.75	0.82	1.00	0.62	0.62	1.03
0.85	10.24	0.00	997.4	105.8	123.3								
8.16	6.28	1.02	37.0	0.80	29.6	0.41	0.23	0.75	0.82	1.00	0.62	0.62	1.03
0.85	10.27	0.00	997.8	106.1	123.7								
8.10	6.28	1.02	37.0	0.80	29.6	0.40	0.23	0.75	0.82	1.00	0.62	0.62	1.02
0.85	10.29	0.00	998.1	106.5	124.0								
8.04	6.28	1.01	37.0	0.80	29.6	0.40	0.23	0.75	0.82	1.00	0.62	0.62	1.02
0.85	10.32	0.00	998.5	106.8	124.4								
7.98	6.28	1.00	37.0	0.80	29.6	0.40	0.23	0.75	0.82	1.00	0.62	0.62	1.02
0.85	10.35	0.00	998.9	107.2	124.7								
7.92	6.28	0.99	37.0	0.80	29.6	0.40	0.23	0.75	0.82	1.00	0.62	0.62	1.01

													Ødetail		
0.84	10.38	0.00	999.3	107.5	125.1										
7.86	6.28	0.99	37.0	0.80	29.6	0.39	0.22	0.75	0.82	1.00	0.62	0.62	1.01		
0.84	10.41	0.00	999.7	107.9	125.4										
7.80	6.28	0.98	37.0	0.80	29.6	0.39	0.22	0.75	0.82	1.00	0.62	0.62	1.01		
0.84	10.44	0.00	1000.0	108.2	125.8										
7.74	6.28	0.97	37.0	0.80	29.6	0.39	0.22	0.75	0.82	1.00	0.62	0.62	1.00		
0.84	10.46	0.00	1000.4	108.5	126.1										
7.69	6.28	0.96	37.0	0.80	29.6	0.38	0.22	0.75	0.82	1.00	0.62	0.62	1.00		
0.84	10.49	0.00	1000.8	108.9	126.4										
7.63	6.28	0.96	37.0	0.80	29.6	0.38	0.22	0.75	0.82	1.00	0.62	0.62	1.00		
0.84	10.52	0.00	1001.1	109.2	126.8										
7.57	6.28	0.95	37.0	0.80	29.6	0.38	0.22	0.75	0.82	1.00	0.62	0.62	1.00		
0.83	10.55	0.00	1001.5	109.5	127.1										
7.51	6.28	0.94	37.0	0.80	29.6	0.37	0.21	0.75	0.82	1.00	0.62	0.62	0.99		
0.83	10.58	0.00	1001.9	109.9	127.5										
7.45	6.28	0.93	37.0	0.80	29.6	0.37	0.21	0.75	0.82	1.00	0.62	0.62	0.99		
0.83	10.61	0.00	1002.3	110.2	127.8										
7.39	6.28	0.93	37.0	0.80	29.6	0.37	0.21	0.75	0.82	1.00	0.62	0.62	0.99		
0.83	10.63	0.00	1002.6	110.6	128.1										
7.33	6.28	0.92	37.0	0.80	29.6	0.37	0.21	0.75	0.82	1.00	0.62	0.62	0.98		
0.83	10.66	0.00	1003.0	110.9	128.5										
7.27	6.28	0.91	37.0	0.80	29.6	0.36	0.21	0.75	0.82	1.00	0.62	0.62	0.98		
0.83	10.69	0.00	1003.3	111.2	128.8										
7.21	6.28	0.91	37.0	0.80	29.6	0.36	0.21	0.75	0.82	1.00	0.62	0.62	0.98		
0.82	10.72	0.00	1003.7	111.6	129.1										
7.15	6.28	0.90	37.0	0.80	29.6	0.36	0.20	0.75	0.82	1.00	0.62	0.62	0.98		
0.82	10.75	0.00	1004.1	111.9	129.5										
7.09	6.28	0.89	37.0	0.80	29.6	0.35	0.20	0.75	0.82	1.00	0.62	0.62	0.97		
0.82	10.78	0.00	1004.4	112.2	129.8										
7.04	6.28	0.88	37.0	0.80	29.6	0.35	0.20	0.75	0.82	1.00	0.62	0.62	0.97		
0.82	10.81	0.00	1004.8	112.6	130.1										
6.98	6.28	0.88	37.0	0.80	29.6	0.35	0.20	0.75	0.82	1.00	0.62	0.62	0.97		
0.82	10.83	0.00	1005.2	112.9	130.5										
6.92	6.28	0.87	37.0	0.80	29.6	0.35	0.20	0.75	0.82	1.00	0.62	0.62	0.96		
0.82	10.86	0.00	1005.5	113.2	130.8										
6.86	6.28	0.86	37.0	0.80	29.6	0.34	0.20	0.75	0.82	1.00	0.62	0.62	0.96		
0.81	10.89	0.00	1005.9	113.6	131.1										
6.80	6.28	0.85	37.0	0.80	29.6	0.34	0.19	0.75	0.82	1.00	0.62	0.62	0.96		
0.81	10.92	0.00	1006.2	113.9	131.5										
6.74	6.28	0.85	37.0	0.80	29.6	0.34	0.19	0.75	0.82	1.00	0.62	0.62	0.95		
0.81	10.95	0.00	1006.6	114.2	131.8										
6.68	6.28	0.84	37.0	0.80	29.6	0.33	0.19	0.75	0.82	1.00	0.62	0.62	0.95		
0.81	10.98	0.00	1006.9	114.5	132.1										
6.62	6.28	0.83	37.0	0.80	29.6	0.33	0.19	0.75	0.82	1.00	0.62	0.62	0.95		
0.81	11.00	0.00	1007.3	114.9	132.4										
6.56	6.28	0.82	37.0	0.80	29.6	0.33	0.19	0.75	0.82	1.00	0.62	0.62	0.95		
0.81	11.03	0.00	1007.6	115.2	132.8										
6.50	6.28	0.82	37.0	0.80	29.6	0.32	0.19	0.75	0.82	1.00	0.62	0.62	0.94		
0.80	11.06	0.00	1008.0	115.5	133.1										
6.44	6.28	0.81	37.0	0.80	29.6	0.32	0.18	0.75	0.82	1.00	0.62	0.62	0.94		
0.80	11.09	0.00	1008.3	115.9	133.4										
6.38	6.28	0.80	37.0	0.80	29.6	0.32	0.18	0.75	0.82	1.00	0.62	0.62	0.94		
0.80	11.12	0.00	1008.7	116.2	133.7										
6.33	6.28	0.79	37.0	0.80	29.6	0.32	0.18	0.75	0.82	1.00	0.62	0.62	0.93		
0.80	11.15	0.00	1009.0	116.5	134.1										
6.27	6.28	0.79	37.0	0.80	29.6	0.31	0.18	0.75	0.82	1.00	0.62	0.62	0.93		
0.80	11.18	0.00	1009.4	116.8	134.4										
6.21	6.28	0.78	37.0	0.80	29.6	0.31	0.18	0.75	0.82	1.00	0.62	0.62	0.93		
0.80	11.20	0.00	1009.7	117.2	134.7										
6.15	6.28	0.77	37.0	0.80	29.6	0.31	0.18	0.75	0.82	1.00	0.62	0.62	0.93		
0.79	11.23	0.00	1010.1	117.5	135.0										
6.09	6.28	0.76	37.0	0.80	29.6	0.30	0.17	0.75	0.82	1.00	0.62	0.62	0.92		
0.79	11.26	0.00	1010.4	117.8	135.3										
6.03	6.28	0.76	37.0	0.80	29.6	0.30	0.17	0.75	0.82	1.00	0.62	0.62	0.92		
0.79	11.29	0.00	1010.8	118.1	135.7										
5.97	6.28	0.75	37.0	0.80	29.6	0.30	0.17	0.75	0.82	1.00	0.62	0.62	0.92		
0.79	11.32	0.00	1011.1	118.4	136.0										

													0detail
5.91	6.28	0.74	37.0	0.80	29.6	0.30	0.17	0.75	0.82	1.00	0.62	0.62	0.91
0.79	11.35	0.00	1011.4	118.8	136.3								
5.85	6.28	0.74	37.0	0.80	29.6	0.29	0.17	0.75	0.82	1.00	0.62	0.62	0.91
0.79	11.37	0.00	1011.8	119.1	136.6								
5.79	6.28	0.73	37.0	0.80	29.6	0.29	0.17	0.75	0.82	1.00	0.62	0.62	0.91
0.78	11.40	0.00	1012.1	119.4	136.9								
5.73	6.28	0.72	37.0	0.80	29.6	0.29	0.16	0.75	0.82	1.00	0.62	0.62	0.90
0.78	11.43	0.00	1012.4	119.7	137.2								
5.68	6.28	0.71	37.0	0.80	29.6	0.28	0.16	0.75	0.82	1.00	0.62	0.62	0.90
0.78	11.46	0.00	1012.8	120.0	137.6								
5.62	6.28	0.71	37.0	0.80	29.6	0.28	0.16	0.75	0.82	1.00	0.62	0.62	0.90
0.78	11.49	0.00	1013.1	120.4	137.9								
5.56	6.28	0.70	37.0	0.80	29.6	0.28	0.16	0.75	0.82	1.00	0.62	0.62	0.90
0.78	11.52	0.00	1013.4	120.7	138.2								
5.50	6.28	0.69	37.0	0.80	29.6	0.27	0.16	0.75	0.82	1.00	0.62	0.62	0.89
0.78	11.54	0.00	1013.8	121.0	138.5								
5.44	6.28	0.68	37.0	0.80	29.6	0.27	0.16	0.75	0.82	1.00	0.62	0.62	0.89
0.77	11.57	0.00	1014.1	121.3	138.8								
5.38	6.28	0.68	37.0	0.80	29.6	0.27	0.15	0.75	0.82	1.00	0.62	0.62	0.89
0.77	11.60	0.00	1014.4	121.6	139.1								
5.32	6.28	0.67	37.0	0.80	29.6	0.27	0.15	0.75	0.82	1.00	0.62	0.62	0.88
0.77	11.63	0.00	1014.8	121.9	139.4								
5.26	6.28	0.66	37.0	0.80	29.6	0.26	0.15	0.75	0.82	1.00	0.62	0.62	0.88
0.77	11.66	0.00	1015.1	122.3	139.7								
5.20	6.28	0.65	37.0	0.80	29.6	0.26	0.15	0.75	0.82	1.00	0.62	0.62	0.88
0.77	11.69	0.00	1015.4	122.6	140.0								
5.14	6.28	0.65	37.0	0.80	29.6	0.26	0.15	0.75	0.82	1.00	0.62	0.62	0.88
0.77	11.72	0.00	1015.7	122.9	140.3								
5.08	6.28	0.64	37.0	0.80	29.6	0.25	0.15	0.75	0.82	1.00	0.62	0.62	0.87
0.76	11.74	0.00	1016.1	123.2	140.6								
5.03	6.28	0.63	37.0	0.80	29.6	0.25	0.14	0.75	0.82	1.00	0.62	0.62	0.87
0.76	11.77	0.00	1016.4	123.5	140.9								
4.97	6.28	0.62	37.0	0.80	29.6	0.25	0.14	0.75	0.82	1.00	0.62	0.62	0.87
0.76	11.80	0.00	1016.7	123.8	141.2								
4.91	6.28	0.62	37.0	0.80	29.6	0.25	0.14	0.75	0.82	1.00	0.62	0.62	0.86
0.76	11.83	0.00	1017.0	124.1	141.5								
4.85	6.28	0.61	37.0	0.80	29.6	0.24	0.14	0.75	0.82	1.00	0.62	0.62	0.86
0.76	11.86	0.00	1017.4	124.4	141.8								
4.79	6.28	0.60	37.0	0.80	29.6	0.24	0.14	0.75	0.82	1.00	0.62	0.62	0.86
0.76	11.89	0.00	1017.7	124.7	142.1								
4.73	6.28	0.59	37.0	0.80	29.6	0.24	0.14	0.75	0.82	1.00	0.62	0.62	0.86
0.75	11.91	0.00	1018.0	125.1	142.4								
4.67	6.28	0.59	37.0	0.80	29.6	0.23	0.13	0.75	0.82	1.00	0.62	0.62	0.85
0.75	11.94	0.00	1018.3	125.4	142.7								
4.61	6.28	0.58	37.0	0.80	29.6	0.23	0.13	0.75	0.82	1.00	0.62	0.62	0.85
0.75	11.97	0.00	1018.6	125.7	143.0								
4.55	6.28	0.57	37.0	0.80	29.6	0.23	0.13	0.75	0.82	1.00	0.62	0.62	0.85
0.75	12.00	0.00	1018.9	126.0	143.3								
4.49	6.28	0.57	37.0	0.80	29.6	0.22	0.13	0.75	0.82	1.00	0.62	0.62	0.84
0.75	12.03	0.00	1019.3	126.3	143.6								
4.43	6.28	0.56	37.0	0.80	29.6	0.22	0.13	0.75	0.82	1.00	0.62	0.62	0.84
0.75	12.06	0.00	1019.6	126.6	143.9								
4.37	6.28	0.55	37.0	0.80	29.6	0.22	0.13	0.75	0.82	1.00	0.62	0.62	0.84
0.74	12.09	0.00	1019.9	126.9	144.2								
4.32	6.28	0.54	37.0	0.80	29.6	0.22	0.12	0.75	0.82	1.00	0.62	0.62	0.83
0.74	12.11	0.00	1020.2	127.2	144.5								
4.26	6.28	0.54	37.0	0.80	29.6	0.21	0.12	0.75	0.82	1.00	0.62	0.62	0.83
0.74	12.14	0.00	1020.5	127.5	144.8								
4.20	6.28	0.53	37.0	0.80	29.6	0.21	0.12	0.75	0.82	1.00	0.62	0.62	0.83
0.74	12.17	0.00	1020.8	127.8	145.1								
4.14	6.28	0.52	37.0	0.80	29.6	0.21	0.12	0.75	0.82	1.00	0.62	0.62	0.83
0.74	12.20	0.00	1021.1	128.1	145.4								
4.08	6.28	0.51	37.0	0.80	29.6	0.20	0.12	0.75	0.82	1.00	0.62	0.62	0.82
0.74	12.23	0.00	1021.4	128.4	145.7								
4.02	6.28	0.51	37.0	0.80	29.6	0.20	0.12	0.75	0.82	1.00	0.62	0.62	0.82
0.73	12.26	0.00	1021.7	128.7	146.0								
3.96	6.28	0.50	37.0	0.80	29.6	0.20	0.11	0.75	0.82	1.00	0.62	0.62	0.82

Ødetail													
0.73	12.28	0.00	1022.0	129.0	146.2								
3.90	6.28	0.49	37.0	0.80	29.6	0.20	0.11	0.75	0.82	1.00	0.62	0.62	0.81
0.73	12.31	0.00	1022.3	129.3	146.5								
3.84	6.28	0.48	37.0	0.80	29.6	0.19	0.11	0.75	0.82	1.00	0.62	0.62	0.81
0.73	12.34	0.00	1022.6	129.6	146.8								
3.78	6.28	0.48	37.0	0.80	29.6	0.19	0.11	0.75	0.82	1.00	0.62	0.62	0.81
0.73	12.37	0.00	1022.9	129.9	147.1								
3.72	6.28	0.47	37.0	0.80	29.6	0.19	0.11	0.75	0.82	1.00	0.62	0.62	0.81
0.73	12.40	0.00	1023.2	130.2	147.4								
3.67	6.28	0.46	37.0	0.80	29.6	0.18	0.10	0.75	0.82	1.00	0.62	0.62	0.80
0.72	12.43	0.00	1023.5	130.5	147.7								
3.61	6.28	0.45	37.0	0.80	29.6	0.18	0.10	0.75	0.82	1.00	0.62	0.62	0.80
0.72	12.45	0.00	1023.8	130.8	147.9								
3.55	6.28	0.45	37.0	0.80	29.6	0.18	0.10	0.75	0.82	1.00	0.62	0.62	0.80
0.72	12.48	0.00	1024.1	131.1	148.2								
3.49	6.28	0.44	37.0	0.80	29.6	0.17	0.10	0.75	0.82	1.00	0.62	0.62	0.79
0.72	12.51	0.00	1024.4	131.4	148.5								
3.43	6.28	0.43	37.0	0.80	29.6	0.17	0.10	0.75	0.82	1.00	0.62	0.62	0.79
0.72	12.54	0.00	1024.7	131.7	148.8								
3.37	6.28	0.42	37.0	0.80	29.6	0.17	0.10	0.75	0.82	1.00	0.62	0.62	0.79
0.72	12.57	0.00	1025.0	132.0	149.1								
3.31	6.28	0.42	37.0	0.80	29.6	0.17	0.09	0.75	0.82	1.00	0.62	0.62	0.78
0.71	12.60	0.00	1025.3	132.3	149.3								
3.25	6.28	0.41	37.0	0.80	29.6	0.16	0.09	0.75	0.82	1.00	0.62	0.62	0.78
0.71	12.63	0.00	1025.6	132.6	149.6								
3.19	6.28	0.40	37.0	0.80	29.6	0.16	0.09	0.75	0.82	1.00	0.62	0.62	0.78
0.71	12.65	0.00	1025.9	132.9	149.9								
3.13	6.28	0.40	37.0	0.80	29.6	0.16	0.09	0.75	0.82	1.00	0.62	0.62	0.78
0.71	12.68	0.00	1026.2	133.1	150.2								
3.07	6.28	0.39	37.0	0.80	29.6	0.15	0.09	0.75	0.82	1.00	0.62	0.62	0.77
0.71	12.71	0.00	1026.4	133.4	150.5								
3.02	6.28	0.38	37.0	0.80	29.6	0.15	0.09	0.75	0.82	1.00	0.62	0.62	0.77
0.70	12.74	0.00	1026.7	133.7	150.7								
2.96	6.28	0.37	37.0	0.80	29.6	0.15	0.08	0.75	0.82	1.00	0.62	0.62	0.77
0.70	12.77	0.00	1027.0	134.0	151.0								
2.90	6.28	0.37	37.0	0.80	29.6	0.15	0.08	0.75	0.82	1.00	0.62	0.62	0.76
0.70	12.80	0.00	1027.3	134.3	151.3								
2.84	6.28	0.36	37.0	0.80	29.6	0.14	0.08	0.75	0.82	1.00	0.62	0.62	0.76
0.70	12.82	0.00	1027.6	134.6	151.5								
2.78	6.28	0.35	37.0	0.80	29.6	0.14	0.08	0.75	0.82	1.00	0.62	0.62	0.76
0.70	12.85	0.00	1027.9	134.9	151.8								
2.72	6.28	0.34	37.0	0.80	29.6	0.14	0.08	0.75	0.82	1.00	0.62	0.62	0.76
0.70	12.88	0.00	1028.1	135.2	152.1								
2.66	6.28	0.34	37.0	0.80	29.6	0.13	0.08	0.75	0.82	1.00	0.62	0.62	0.75
0.69	12.91	0.00	1028.4	135.5	152.4								
2.60	6.28	0.33	37.0	0.80	29.6	0.13	0.07	0.75	0.82	1.00	0.62	0.62	0.75
0.69	12.94	0.00	1028.7	135.7	152.6								
2.54	6.28	0.32	37.0	0.80	29.6	0.13	0.07	0.75	0.82	1.00	0.62	0.62	0.75
0.69	12.97	0.00	1029.0	136.0	152.9								
2.48	6.28	0.31	37.0	0.70	25.9	0.11	0.06	0.75	0.82	1.00	0.62	0.62	0.73
0.68	13.00	0.00	1029.2	136.3	153.1								
2.42	6.28	0.31	37.0	0.70	25.9	0.10	0.06	0.75	0.82	1.00	0.62	0.62	0.72
0.68	13.02	0.00	1029.5	136.6	153.4								
2.36	6.28	0.30	37.0	0.70	25.9	0.10	0.06	0.75	0.82	1.00	0.62	0.62	0.72
0.68	13.05	0.00	1029.8	136.9	153.7								
2.31	6.28	0.29	37.0	0.70	25.9	0.10	0.06	0.75	0.82	1.00	0.62	0.62	0.72
0.68	13.08	0.00	1030.0	137.1	153.9								
2.25	6.28	0.28	37.0	0.70	25.9	0.10	0.06	0.75	0.82	1.00	0.62	0.62	0.72
0.67	13.11	0.00	1030.3	137.4	154.2								
2.19	6.28	0.28	37.0	0.70	25.9	0.09	0.05	0.75	0.82	1.00	0.62	0.62	0.71
0.67	13.14	0.00	1030.6	137.7	154.4								
2.13	6.28	0.27	37.0	0.70	25.9	0.09	0.05	0.75	0.82	1.00	0.62	0.62	0.71
0.67	13.17	0.00	1030.8	138.0	154.7								
2.07	6.28	0.26	37.0	0.70	25.9	0.09	0.05	0.75	0.82	1.00	0.62	0.62	0.71
0.67	13.19	0.00	1031.1	138.3	155.0								
2.01	6.28	0.25	37.0	0.70	25.9	0.09	0.05	0.75	0.82	1.00	0.62	0.62	0.71
0.67	13.22	0.00	1031.4	138.5	155.2								

							0detail						
1.95	6.28	0.25	37.0	0.70	25.9	0.08	0.05	0.75	0.82	1.00	0.62	0.62	0.70
0.67	13.25	0.00	1031.6	138.8	155.5								
1.89	6.28	0.24	37.0	0.70	25.9	0.08	0.05	0.75	0.82	1.00	0.62	0.62	0.70
0.67	13.28	0.00	1031.9	139.1	155.7								
1.83	6.28	0.23	37.0	0.70	25.9	0.08	0.05	0.75	0.82	1.00	0.62	0.62	0.70
0.66	13.31	0.00	1032.1	139.4	156.0								
1.77	6.28	0.23	37.0	0.70	25.9	0.08	0.04	0.75	0.82	1.00	0.62	0.62	0.70
0.66	13.34	0.00	1032.4	139.6	156.2								
1.71	6.28	0.22	37.0	0.70	25.9	0.07	0.04	0.75	0.82	1.00	0.62	0.62	0.69
0.66	13.36	0.00	1032.7	139.9	156.5								
1.66	6.28	0.21	37.0	0.70	25.9	0.07	0.04	0.75	0.82	1.00	0.62	0.62	0.69
0.66	13.39	0.00	1032.9	140.2	156.7								
1.60	6.28	0.20	37.0	0.70	25.9	0.07	0.04	0.75	0.82	1.00	0.62	0.62	0.69
0.66	13.42	0.00	1033.2	140.5	157.0								
1.54	6.28	0.20	37.0	0.70	25.9	0.07	0.04	0.75	0.82	1.00	0.62	0.62	0.69
0.66	13.45	0.00	1033.4	140.7	157.2								
1.48	6.28	0.19	37.0	0.70	25.9	0.06	0.04	0.75	0.82	1.00	0.62	0.62	0.68
0.66	13.48	0.00	1033.7	141.0	157.5								
1.42	6.28	0.18	37.0	0.70	25.9	0.06	0.04	0.75	0.82	1.00	0.62	0.62	0.68
0.65	13.51	0.00	1033.9	141.3	157.7								
1.36	6.28	0.17	37.0	0.70	25.9	0.06	0.03	0.75	0.82	1.00	0.62	0.62	0.68
0.65	13.54	0.00	1034.2	141.5	158.0								
1.30	6.28	0.17	37.0	0.70	25.9	0.06	0.03	0.75	0.82	1.00	0.62	0.62	0.67
0.65	13.56	0.00	1034.4	141.8	158.2								
1.24	6.28	0.16	37.0	0.70	25.9	0.05	0.03	0.75	0.82	1.00	0.62	0.62	0.67
0.65	13.59	0.00	1034.7	142.1	158.5								
1.18	6.28	0.15	37.0	0.70	25.9	0.05	0.03	0.75	0.82	1.00	0.62	0.62	0.67
0.65	13.62	0.00	1034.9	142.4	158.7								
1.12	6.28	0.14	37.0	0.70	25.9	0.05	0.03	0.75	0.82	1.00	0.62	0.62	0.67
0.65	13.65	0.00	1035.2	142.6	158.9								
1.06	6.28	0.14	37.0	0.70	25.9	0.05	0.03	0.75	0.82	1.00	0.62	0.62	0.66
0.65	13.68	0.00	1035.4	142.9	159.2								
1.01	6.28	0.13	37.0	0.70	25.9	0.04	0.03	0.75	0.82	1.00	0.62	0.62	0.66
0.64	13.71	0.00	1035.7	143.2	159.4								
0.95	6.28	0.12	37.0	0.70	25.9	0.04	0.02	0.75	0.82	1.00	0.62	0.62	0.66
0.64	13.73	0.00	1035.9	143.4	159.7								
0.89	6.28	0.11	37.0	0.70	25.9	0.04	0.02	0.75	0.82	1.00	0.62	0.62	0.66
0.64	13.76	0.00	1036.2	143.7	159.9								
0.83	6.28	0.11	37.0	0.70	25.9	0.04	0.02	0.75	0.82	1.00	0.62	0.62	0.65
0.64	13.79	0.00	1036.4	144.0	160.2								
0.77	6.28	0.10	37.0	0.70	25.9	0.03	0.02	0.75	0.82	1.00	0.62	0.62	0.65
0.64	13.82	0.00	1036.7	144.2	160.4								
0.71	6.28	0.09	37.0	0.70	25.9	0.03	0.02	0.75	0.82	1.00	0.62	0.62	0.65
0.64	13.85	0.00	1036.9	144.5	160.6								
0.65	6.28	0.08	37.0	0.70	25.9	0.03	0.02	0.75	0.82	1.00	0.62	0.62	0.65
0.63	13.88	0.00	1037.1	144.7	160.9								
0.59	6.28	0.08	37.0	0.70	25.9	0.03	0.02	0.75	0.82	1.00	0.62	0.62	0.64
0.63	13.91	0.00	1037.4	145.0	161.1								
0.53	6.28	0.07	37.0	0.70	25.9	0.02	0.01	0.75	0.82	1.00	0.62	0.62	0.64
0.63	13.93	0.00	1037.6	145.3	161.3								
0.47	6.28	0.06	37.0	0.70	25.9	0.02	0.01	0.75	0.82	1.00	0.62	0.62	0.64
0.63	13.96	0.00	1037.8	145.5	161.6								
0.41	6.28	0.06	37.0	0.70	25.9	0.02	0.01	0.75	0.82	1.00	0.62	0.62	0.64
0.63	13.99	0.00	1038.1	145.8	161.8								
0.35	6.28	0.05	37.0	0.70	25.9	0.02	0.01	0.75	0.82	1.00	0.62	0.62	0.63
0.63	14.02	0.00	1038.3	146.1	162.1								
0.30	6.28	0.04	37.0	0.70	25.9	0.01	0.01	0.75	0.82	1.00	0.62	0.62	0.63
0.63	14.05	0.00	1038.6	146.3	162.3								
0.24	6.28	0.03	37.0	0.70	25.9	0.01	0.01	0.75	0.82	1.00	0.62	0.62	0.63
0.62	14.08	0.00	1038.8	146.6	162.5								
0.18	6.28	0.03	37.0	0.70	25.9	0.01	0.01	0.75	0.82	1.00	0.62	0.62	0.63
0.62	14.10	0.00	1039.0	146.8	162.8								
0.12	6.28	0.02	37.0	0.70	25.9	0.01	0.00	0.75	0.82	1.00	0.62	0.62	0.62
0.62	14.13	0.00	1039.3	147.1	163.0								
0.06	6.28	0.01	37.0	0.70	25.9	0.00	0.00	0.75	0.82	1.00	0.62	0.62	0.62
0.62	14.16	0.00	1039.5	147.4	163.2								
0.00	6.28	0.00	37.0	0.70	25.9	0.00	0.00	0.75	0.82	1.00	0.62	0.62	0.62

Ødetail

0.62 14.43 0.00 1039.7 147.9 163.4

SETTLEMENT based on Ultimate Loading by Vesic Method (1977):

Ztip=29.50 Btip= 2.00 Cp= 0.135 Cs= 0.209
 Xpp=2.545-in Xps= 0.061-in Xtip= 2.606-in
 Cp & Cs are average value at bearing stratum from pile tip extend to 10 Btip

At loading: Qtip=846.3-kp Qtop= 1039.7-kp Qside= 193.4-kp
 Xtip=2.606-in Xtop= 2.838-in Xshaft= 0.232-in

LOAD - TOTAL SETTLEMENT RELATION (from t-z, and q-w curves):

Based on Vesic Method (1977)

Xtop -in	Xshaft -in	Xtip -in	Qtip -kp	Qside -kp	Qtotal -kp
0.0004	0.0004	0.0000	1.1	1.1	2.2
0.0463	0.0138	0.0326	24.0	65.5	89.5
0.0684	0.0196	0.0489	35.5	90.4	125.9
0.0900	0.0249	0.0651	47.0	111.2	158.2
0.1112	0.0297	0.0814	58.5	128.5	186.9
0.1320	0.0343	0.0977	69.9	142.7	212.6
0.1524	0.0384	0.1140	81.4	154.3	235.6
0.1726	0.0423	0.1303	92.8	163.6	256.4
0.1926	0.0460	0.1466	104.2	171.1	275.2
0.2123	0.0495	0.1629	115.5	177.0	292.4
0.2319	0.0527	0.1791	126.8	181.5	308.3
0.2513	0.0559	0.1954	138.0	185.0	323.0
0.2706	0.0589	0.2117	149.1	187.6	336.8
0.2898	0.0618	0.2280	160.2	189.6	349.8
0.3090	0.0647	0.2443	171.2	191.0	362.2
0.3280	0.0674	0.2606	182.2	191.9	374.1
0.3470	0.0702	0.2769	193.0	192.6	385.6
0.3660	0.0728	0.2931	203.8	193.0	396.8
0.3849	0.0754	0.3094	214.5	193.3	407.8
0.4037	0.0780	0.3257	225.1	193.4	418.5
0.4226	0.0806	0.3420	235.5	193.4	429.0
0.4414	0.0831	0.3583	245.9	193.4	439.3
0.4601	0.0856	0.3746	256.2	193.3	449.5
0.4788	0.0880	0.3908	266.4	193.2	459.6
0.4975	0.0904	0.4071	276.4	193.0	469.4
0.5162	0.0928	0.4234	286.4	192.7	479.1
0.5348	0.0951	0.4397	296.2	192.4	488.6
0.5534	0.0974	0.4560	305.9	192.0	497.9
0.5720	0.0997	0.4723	315.5	191.5	507.0
0.5905	0.1019	0.4886	325.0	190.9	515.8
0.6089	0.1041	0.5048	334.3	190.1	524.4
0.6274	0.1062	0.5211	343.5	189.3	532.8
0.6457	0.1083	0.5374	352.6	188.4	541.0
0.6641	0.1104	0.5537	361.6	187.4	549.0
0.6824	0.1124	0.5700	370.4	186.3	556.8
0.7007	0.1144	0.5863	379.2	185.3	564.4
0.7189	0.1163	0.6026	387.7	184.3	572.0
0.7371	0.1183	0.6188	396.2	183.3	579.6
0.7553	0.1202	0.6351	404.5	182.6	587.1
0.7737	0.1222	0.6514	412.8	182.9	595.7
0.7919	0.1242	0.6677	420.8	182.8	603.6
0.8101	0.1261	0.6840	428.8	182.6	611.4
0.8282	0.1280	0.7003	436.6	182.4	619.0
0.8464	0.1298	0.7166	444.3	182.2	626.6
0.8645	0.1316	0.7328	451.9	182.0	633.9
0.8825	0.1334	0.7491	459.4	181.9	641.2
0.9006	0.1352	0.7654	466.7	181.7	648.3
0.9186	0.1369	0.7817	473.9	181.4	655.3
0.9366	0.1386	0.7980	481.0	181.2	662.2
0.9545	0.1402	0.8143	487.9	181.0	669.0
0.9724	0.1419	0.8306	494.8	180.8	675.6
0.9903	0.1435	0.8468	501.5	180.6	682.1

Ødetail

1.0082	0.1451	0.8631	508.1	180.3	688.4
1.0260	0.1466	0.8794	514.6	180.1	694.7
1.0438	0.1481	0.8957	521.0	179.8	700.8
1.0616	0.1496	0.9120	527.3	179.6	706.9
1.0793	0.1511	0.9283	533.4	179.4	712.8
1.0971	0.1525	0.9446	539.5	179.1	718.6
1.1148	0.1539	0.9608	545.4	178.9	724.3
1.1324	0.1553	0.9771	551.3	178.7	729.9
1.1501	0.1567	0.9934	557.0	178.4	735.4
1.1677	0.1580	1.0097	562.6	178.2	740.8
1.1853	0.1593	1.0260	568.2	178.0	746.1
1.2029	0.1606	1.0423	573.6	177.8	751.3
1.2204	0.1619	1.0585	578.9	177.5	756.5
1.2380	0.1631	1.0748	584.2	177.3	761.5
1.2555	0.1644	1.0911	589.3	177.1	766.5
1.2730	0.1656	1.1074	594.4	177.0	771.3
1.2904	0.1667	1.1237	599.4	176.8	776.1
1.3079	0.1679	1.1400	604.3	176.6	780.8
1.3253	0.1691	1.1563	609.1	176.4	785.5
1.3427	0.1702	1.1725	613.8	176.2	790.0
1.3601	0.1713	1.1888	618.4	176.1	794.5
1.3775	0.1724	1.2051	623.0	175.9	798.8
1.3948	0.1734	1.2214	627.5	175.7	803.1
1.4122	0.1745	1.2377	631.9	175.4	807.3
1.4295	0.1755	1.2540	636.2	175.2	811.4
1.4468	0.1765	1.2703	640.5	174.9	815.4
1.4640	0.1775	1.2865	644.7	174.6	819.3
1.4813	0.1785	1.3028	648.8	174.5	823.4
1.4985	0.1794	1.3191	652.9	174.3	827.3
1.5158	0.1804	1.3354	656.9	174.2	831.1
1.5330	0.1813	1.3517	660.9	174.0	834.9
1.5502	0.1822	1.3680	664.8	173.8	838.6
1.5674	0.1832	1.3843	668.6	173.7	842.3
1.5846	0.1840	1.4005	672.4	173.5	845.9
1.6018	0.1849	1.4168	676.1	173.4	849.4
1.6189	0.1858	1.4331	679.8	173.2	852.9
1.6361	0.1867	1.4494	683.4	173.0	856.4
1.6532	0.1875	1.4657	686.9	172.9	859.8
1.6703	0.1883	1.4820	690.5	172.7	863.2
1.6874	0.1892	1.4983	693.9	172.5	866.5
1.7045	0.1900	1.5145	697.4	172.4	869.7
1.7216	0.1908	1.5308	700.8	172.2	873.0
1.8239	0.1954	1.6285	720.2	171.2	891.4
2.1629	0.2086	1.9542	776.6	167.9	944.5
2.4989	0.2189	2.2800	820.7	164.6	985.3
2.8304	0.2247	2.6057	846.3	161.3	1007.5
3.1548	0.2235	2.9314	842.7	158.0	1000.7
3.4709	0.2139	3.2571	804.7	154.6	959.4

At Qwork= 460.00-kp Settlement= 0.47968-in
 At Qwork= 460.00-kp Secant Stiffness Kqx= 958.97-kp/-in
 At Xallow= 1.00-in Q= 685.52-kp

Note: If the program cannot find a result or the result exceeds the upper limit. The result will be displayed as 99999.

SUMMARY:

Total Ultimate Capacity (Down)= 1039.718-kp Total Ultimate Capacity (Up)= 147.861-kp
 Total Allowable Capacity (Down)= 552.100-kp Total Allowable Capacity (Up)= 81.146-kp

Weight above Ground= 0.24 Total Pile Weight= 14.43-kp *Soil Weight is not included
 Side Resistance (Down)= 193.448-kp Side Resistance (Up)= 133.431-kp
 Tip Resistance (Down)= 846.269-kp Tip Resistance (Up)= 0.000-kp
 Negative Friction, Qneg= 0.000-kp, which has been subtracted from Total Ultimate Capacity (Down)
 Negative friction does not affect Total Uplift Ultimate Capacity (Up)

OK! Qallow > Q * Vertical Load, Q= 460.0 -kp

Ødetail

FACTOR OF SAFETY:

FSSide FStip FSup FSweight

1.5 2.0 2.0 1.0

* FStorsion = FSSide

Notes:

* Settlement in the program is Elastic Settlement only. Consolidation Settlement is not calculated!

Length - Pile length, distance from pile top to tip (not from ground surface)

Width or D - Width of pile shaft (pile diameter)

Ds and Dl - Short Side and Long Side of Footing

Area - Section area of pile shaft or tip area of pile

Sv - Vertical stress in soils (It may be limited based on critical depth, Z_lim or Z/D

qult - Ultimate tip resistance (pressure)

Qtip_dw - Ultimate downward tip resistance (Force or Capacity)

Qtip_up - Ultimate uplift tip resistance for belled pile or uplift plate (Force or Capacity)

Torsion - Ultimate torsion resistance for single pile (Capacity)

dz - Small Segment of Depth for Calculation

Zs - Soil Depth, Depth from ground surface

Zp - Pile Depth, Depth from pile top

Prem - Primer of pile shaft

Phi - Soil internal friction angle (between soils)

Kf - Friction factor to convert Phi to Delta

Delta - Ski friction between soil and pile (function of Phi. It is different from Phi)

f_dw - Downward Resistance between soil and pile from Delta

f_up - Uplift Resistance between soil and pile from Delta

C - Soil cohesion (between soils)

Ca - Adhesion between soil and pile (function of C. It is different from C) Ca=KaKcC

Ka - Adhesion ratio, C/Ca

Kc - Adhesion factor defended by users

Ca_dw - Downward adhesion between pile and soil

Ca_up - Uplift adhesion between pile and soil

Sf_dw - Downward side resistance (sum of friction and adhesion, f_dw + Ca_dw)

Sf_up - Uplift side resistance (sum of friction and adhesion, f_up + Ca_up)

Torsion side resistance = (Sf_dw+Sf_up)/2 * pile diameter/2

Weight - Weight of Pile shaft

Qneg - negative friction Resistance

Qside - Ultimate side resistance (Qside_dw or Qside_up)

Qtip - Ultimate tip resistance (Qtip_dw or Qtip_up for uplift plate)

Q_dw - Ultimate downward capacity (Qtip + Qside_dw)

Q_up - Ultimate uplift capacity (Weight + Qside_up)

E - Elastic modules

Xs - Settlement due to axial deformation of pile shaft

Xpp - Settlement due to point load from pile tip

Xps - Settlement due to load from pile shaft

Xtop - Total settlement, Xs + Xpp + Xps

Xtip - Tip settlement, Xpp + Xps

Xshaft - Shaft deformation, Xs

Xallow - Allowable settlement specified by users

Qwork - Vertical working load applied to pile

Qallow - Vertical allowable load, Qult/F.S.

SOIL STRESS, SIDE RESISTANCE, & AXIAL FORCE vs DEPTH Based on Ultimate Load Condition

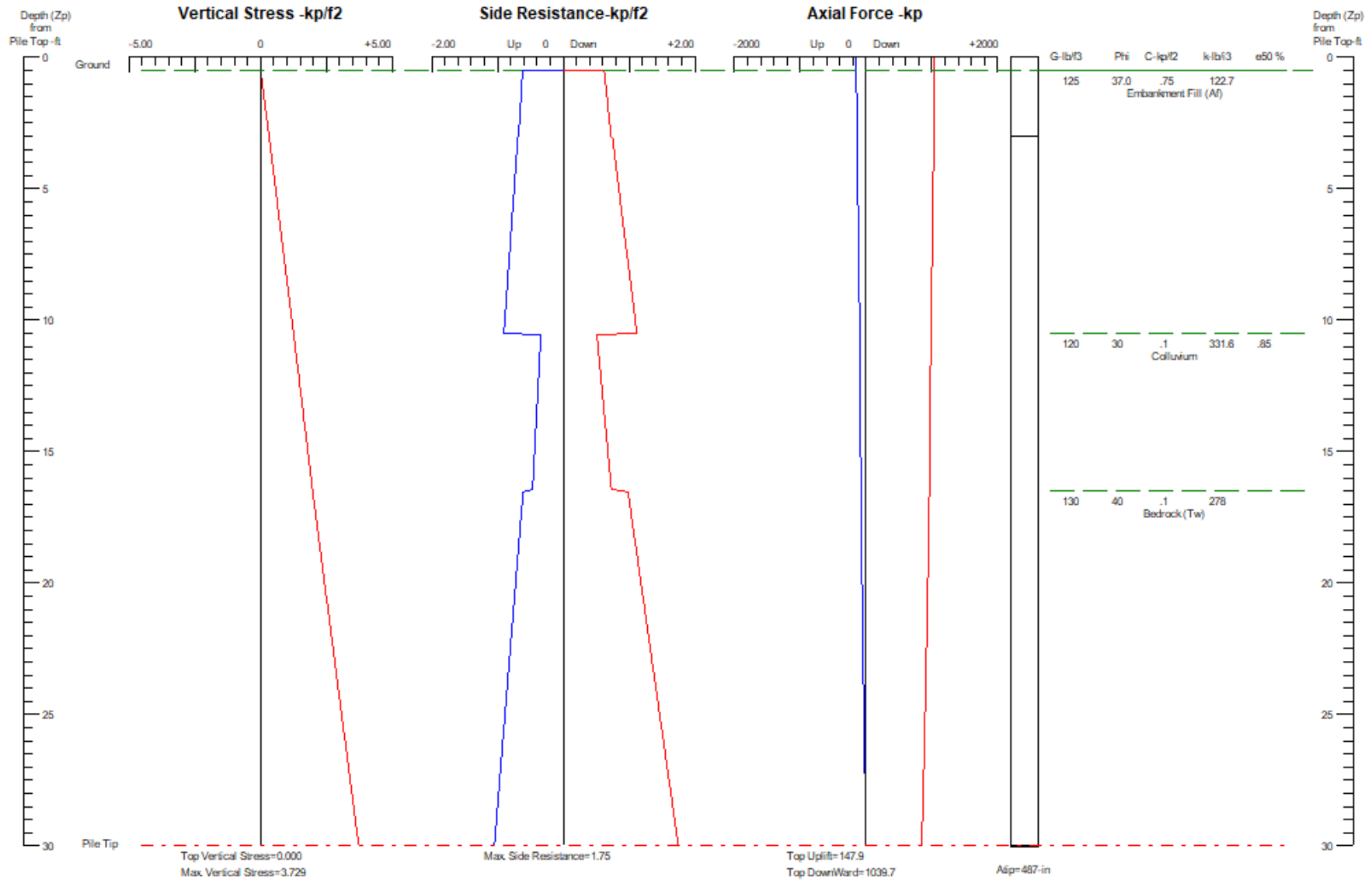

**CivilTech
Software**

**Lot 44
Foundations P9 & P10**

Figure 1

Ødetail

Depth vs. Soil Stress, Side Resistance, and Pile Axial Force:

Zp -ft	Sv -kp/f2	Sf_dw -kp/f2	Sf_up -kp/f2	Q_dw -kp	Q_up -kp
0.0	0.00	0.00	0.00	1039.7	147.9
0.5	0.00	0.00	0.00	1039.7	147.9
0.5	0.00	0.62	0.62	1039.7	147.9
0.6	0.01	0.62	0.62	1039.5	147.4
0.6	0.02	0.62	0.62	1039.3	147.1
0.7	0.03	0.63	0.62	1039.0	146.8
0.7	0.03	0.63	0.62	1038.8	146.6
0.8	0.04	0.63	0.63	1038.6	146.3
0.9	0.05	0.63	0.63	1038.3	146.1
0.9	0.06	0.64	0.63	1038.1	145.8
1.0	0.06	0.64	0.63	1037.8	145.5
1.0	0.07	0.64	0.63	1037.6	145.3
1.1	0.08	0.64	0.63	1037.4	145.0
1.2	0.08	0.65	0.63	1037.1	144.7
1.2	0.09	0.65	0.64	1036.9	144.5
1.3	0.10	0.65	0.64	1036.7	144.2
1.3	0.11	0.65	0.64	1036.4	144.0
1.4	0.11	0.66	0.64	1036.2	143.7
1.4	0.12	0.66	0.64	1035.9	143.4
1.5	0.13	0.66	0.64	1035.7	143.2
1.6	0.14	0.66	0.65	1035.4	142.9
1.6	0.14	0.67	0.65	1035.2	142.6
1.7	0.15	0.67	0.65	1034.9	142.4
1.7	0.16	0.67	0.65	1034.7	142.1
1.8	0.17	0.67	0.65	1034.4	141.8
1.9	0.17	0.68	0.65	1034.2	141.5
1.9	0.18	0.68	0.65	1033.9	141.3
2.0	0.19	0.68	0.66	1033.7	141.0
2.0	0.20	0.69	0.66	1033.4	140.7
2.1	0.20	0.69	0.66	1033.2	140.5
2.2	0.21	0.69	0.66	1032.9	140.2
2.2	0.22	0.69	0.66	1032.7	139.9
2.3	0.23	0.70	0.66	1032.4	139.6
2.3	0.23	0.70	0.66	1032.1	139.4
2.4	0.24	0.70	0.67	1031.9	139.1
2.5	0.25	0.70	0.67	1031.6	138.8
2.5	0.25	0.71	0.67	1031.4	138.5
2.6	0.26	0.71	0.67	1031.1	138.3
2.6	0.27	0.71	0.67	1030.8	138.0
2.7	0.28	0.71	0.67	1030.6	137.7
2.7	0.28	0.72	0.67	1030.3	137.4
2.8	0.29	0.72	0.68	1030.0	137.1
2.9	0.30	0.72	0.68	1029.8	136.9
2.9	0.31	0.72	0.68	1029.5	136.6
3.0	0.31	0.73	0.68	1029.2	136.3
3.0	0.32	0.75	0.69	1029.0	136.0
3.1	0.33	0.75	0.69	1028.7	135.7
3.2	0.34	0.75	0.69	1028.4	135.5
3.2	0.34	0.76	0.70	1028.1	135.2
3.3	0.35	0.76	0.70	1027.9	134.9
3.3	0.36	0.76	0.70	1027.6	134.6
3.4	0.37	0.76	0.70	1027.3	134.3
3.5	0.37	0.77	0.70	1027.0	134.0
3.5	0.38	0.77	0.70	1026.7	133.7
3.6	0.39	0.77	0.71	1026.4	133.4
3.6	0.40	0.78	0.71	1026.2	133.1
3.7	0.40	0.78	0.71	1025.9	132.9
3.8	0.41	0.78	0.71	1025.6	132.6

Ødetail

3.8	0.42	0.78	0.71	1025.3	132.3
3.9	0.42	0.79	0.72	1025.0	132.0
3.9	0.43	0.79	0.72	1024.7	131.7
4.0	0.44	0.79	0.72	1024.4	131.4
4.0	0.45	0.80	0.72	1024.1	131.1
4.1	0.45	0.80	0.72	1023.8	130.8
4.2	0.46	0.80	0.72	1023.5	130.5
4.2	0.47	0.81	0.73	1023.2	130.2
4.3	0.48	0.81	0.73	1022.9	129.9
4.3	0.48	0.81	0.73	1022.6	129.6
4.4	0.49	0.81	0.73	1022.3	129.3
4.5	0.50	0.82	0.73	1022.0	129.0
4.5	0.51	0.82	0.73	1021.7	128.7
4.6	0.51	0.82	0.74	1021.4	128.4
4.6	0.52	0.83	0.74	1021.1	128.1
4.7	0.53	0.83	0.74	1020.8	127.8
4.8	0.54	0.83	0.74	1020.5	127.5
4.8	0.54	0.83	0.74	1020.2	127.2
4.9	0.55	0.84	0.74	1019.9	126.9
4.9	0.56	0.84	0.75	1019.6	126.6
5.0	0.57	0.84	0.75	1019.3	126.3
5.1	0.57	0.85	0.75	1018.9	126.0
5.1	0.58	0.85	0.75	1018.6	125.7
5.2	0.59	0.85	0.75	1018.3	125.4
5.2	0.59	0.86	0.75	1018.0	125.1
5.3	0.60	0.86	0.76	1017.7	124.7
5.3	0.61	0.86	0.76	1017.4	124.4
5.4	0.62	0.86	0.76	1017.0	124.1
5.5	0.62	0.87	0.76	1016.7	123.8
5.5	0.63	0.87	0.76	1016.4	123.5
5.6	0.64	0.87	0.76	1016.1	123.2
5.6	0.65	0.88	0.77	1015.7	122.9
5.7	0.65	0.88	0.77	1015.4	122.6
5.8	0.66	0.88	0.77	1015.1	122.3
5.8	0.67	0.88	0.77	1014.8	121.9
5.9	0.68	0.89	0.77	1014.4	121.6
5.9	0.68	0.89	0.77	1014.1	121.3
6.0	0.69	0.89	0.78	1013.8	121.0
6.1	0.70	0.90	0.78	1013.4	120.7
6.1	0.71	0.90	0.78	1013.1	120.4
6.2	0.71	0.90	0.78	1012.8	120.0
6.2	0.72	0.90	0.78	1012.4	119.7
6.3	0.73	0.91	0.78	1012.1	119.4
6.4	0.74	0.91	0.79	1011.8	119.1
6.4	0.74	0.91	0.79	1011.4	118.8
6.5	0.75	0.92	0.79	1011.1	118.4
6.5	0.76	0.92	0.79	1010.8	118.1
6.6	0.76	0.92	0.79	1010.4	117.8
6.6	0.77	0.93	0.79	1010.1	117.5
6.7	0.78	0.93	0.80	1009.7	117.2
6.8	0.79	0.93	0.80	1009.4	116.8
6.8	0.79	0.93	0.80	1009.0	116.5
6.9	0.80	0.94	0.80	1008.7	116.2
6.9	0.81	0.94	0.80	1008.3	115.9
7.0	0.82	0.94	0.80	1008.0	115.5
7.1	0.82	0.95	0.81	1007.6	115.2
7.1	0.83	0.95	0.81	1007.3	114.9
7.2	0.84	0.95	0.81	1006.9	114.5
7.2	0.85	0.95	0.81	1006.6	114.2
7.3	0.85	0.96	0.81	1006.2	113.9
7.4	0.86	0.96	0.81	1005.9	113.6
7.4	0.87	0.96	0.82	1005.5	113.2
7.5	0.88	0.97	0.82	1005.2	112.9
7.5	0.88	0.97	0.82	1004.8	112.6
7.6	0.89	0.97	0.82	1004.4	112.2
7.7	0.90	0.98	0.82	1004.1	111.9
7.7	0.91	0.98	0.82	1003.7	111.6

Ødetail

7.8	0.91	0.98	0.83	1003.3	111.2
7.8	0.92	0.98	0.83	1003.0	110.9
7.9	0.93	0.99	0.83	1002.6	110.6
7.9	0.93	0.99	0.83	1002.3	110.2
8.0	0.94	0.99	0.83	1001.9	109.9
8.1	0.95	1.00	0.83	1001.5	109.5
8.1	0.96	1.00	0.84	1001.1	109.2
8.2	0.96	1.00	0.84	1000.8	108.9
8.2	0.97	1.00	0.84	1000.4	108.5
8.3	0.98	1.01	0.84	1000.0	108.2
8.4	0.99	1.01	0.84	999.7	107.9
8.4	0.99	1.01	0.84	999.3	107.5
8.5	1.00	1.02	0.85	998.9	107.2
8.5	1.01	1.02	0.85	998.5	106.8
8.6	1.02	1.02	0.85	998.1	106.5
8.7	1.02	1.03	0.85	997.8	106.1
8.7	1.03	1.03	0.85	997.4	105.8
8.8	1.04	1.03	0.85	997.0	105.4
8.8	1.05	1.03	0.86	996.6	105.1
8.9	1.05	1.04	0.86	996.2	104.8
9.0	1.06	1.04	0.86	995.9	104.4
9.0	1.07	1.04	0.86	995.5	104.1
9.1	1.08	1.05	0.86	995.1	103.7
9.1	1.08	1.05	0.86	994.7	103.4
9.2	1.09	1.05	0.87	994.3	103.0
9.2	1.10	1.05	0.87	993.9	102.7
9.3	1.10	1.06	0.87	993.5	102.3
9.4	1.11	1.06	0.87	993.1	102.0
9.4	1.12	1.06	0.87	992.7	101.6
9.5	1.13	1.07	0.87	992.3	101.3
9.5	1.13	1.07	0.88	991.9	100.9
9.6	1.14	1.07	0.88	991.5	100.5
9.7	1.15	1.08	0.88	991.1	100.2
9.7	1.16	1.08	0.88	990.7	99.8
9.8	1.16	1.08	0.88	990.3	99.5
9.8	1.17	1.08	0.88	989.9	99.1
9.9	1.18	1.09	0.89	989.5	98.8
10.0	1.19	1.09	0.89	989.1	98.4
10.0	1.19	1.09	0.89	988.7	98.1
10.1	1.20	1.10	0.89	988.3	97.7
10.1	1.21	1.10	0.89	987.9	97.3
10.2	1.22	1.10	0.89	987.5	97.0
10.3	1.22	1.10	0.90	987.1	96.6
10.3	1.23	1.11	0.90	986.7	96.3
10.4	1.24	1.11	0.90	986.3	95.9
10.4	1.25	1.11	0.90	985.9	95.5
10.5	1.25	1.12	0.90	985.5	95.2
10.6	1.26	0.51	0.34	985.0	94.8
10.6	1.27	0.51	0.34	984.8	94.6
10.7	1.27	0.51	0.34	984.7	94.5
10.7	1.28	0.52	0.35	984.5	94.3
10.8	1.29	0.52	0.35	984.3	94.2
10.8	1.30	0.52	0.35	984.1	94.0
10.9	1.30	0.52	0.35	983.9	93.9
11.0	1.31	0.53	0.35	983.7	93.7
11.0	1.32	0.53	0.35	983.5	93.5
11.1	1.32	0.53	0.35	983.3	93.4
11.1	1.33	0.53	0.35	983.1	93.2
11.2	1.34	0.53	0.36	982.9	93.1
11.3	1.35	0.54	0.36	982.7	92.9
11.3	1.35	0.54	0.36	982.5	92.7
11.4	1.36	0.54	0.36	982.3	92.6
11.4	1.37	0.54	0.36	982.1	92.4
11.5	1.37	0.55	0.36	981.9	92.3
11.6	1.38	0.55	0.36	981.7	92.1
11.6	1.39	0.55	0.36	981.5	91.9
11.7	1.39	0.55	0.37	981.3	91.8

Ødetail

11.7	1.40	0.55	0.37	981.1	91.6
11.8	1.41	0.56	0.37	980.9	91.4
11.9	1.42	0.56	0.37	980.7	91.3
11.9	1.42	0.56	0.37	980.5	91.1
12.0	1.43	0.56	0.37	980.3	90.9
12.0	1.44	0.57	0.37	980.1	90.8
12.1	1.44	0.57	0.37	979.8	90.6
12.1	1.45	0.57	0.38	979.6	90.4
12.2	1.46	0.57	0.38	979.4	90.3
12.3	1.47	0.57	0.38	979.2	90.1
12.3	1.47	0.58	0.38	979.0	89.9
12.4	1.48	0.58	0.38	978.8	89.8
12.4	1.49	0.58	0.38	978.6	89.6
12.5	1.49	0.58	0.38	978.3	89.4
12.6	1.50	0.59	0.38	978.1	89.3
12.6	1.51	0.59	0.39	977.9	89.1
12.7	1.52	0.59	0.39	977.7	88.9
12.7	1.52	0.59	0.39	977.5	88.7
12.8	1.53	0.59	0.39	977.3	88.6
12.9	1.54	0.60	0.39	977.0	88.4
12.9	1.54	0.60	0.39	976.8	88.2
13.0	1.55	0.60	0.39	976.6	88.0
13.0	1.56	0.60	0.39	976.4	87.9
13.1	1.57	0.61	0.40	976.1	87.7
13.2	1.57	0.61	0.40	975.9	87.5
13.2	1.58	0.61	0.40	975.7	87.3
13.3	1.59	0.61	0.40	975.5	87.2
13.3	1.59	0.61	0.40	975.2	87.0
13.4	1.60	0.62	0.40	975.0	86.8
13.4	1.61	0.62	0.40	974.8	86.6
13.5	1.61	0.62	0.41	974.6	86.5
13.6	1.62	0.62	0.41	974.3	86.3
13.6	1.63	0.63	0.41	974.1	86.1
13.7	1.64	0.63	0.41	973.9	85.9
13.7	1.64	0.63	0.41	973.6	85.7
13.8	1.65	0.63	0.41	973.4	85.6
13.9	1.66	0.63	0.41	973.2	85.4
13.9	1.66	0.64	0.41	972.9	85.2
14.0	1.67	0.64	0.42	972.7	85.0
14.0	1.68	0.64	0.42	972.5	84.8
14.1	1.69	0.64	0.42	972.2	84.6
14.2	1.69	0.64	0.42	972.0	84.5
14.2	1.70	0.65	0.42	971.7	84.3
14.3	1.71	0.65	0.42	971.5	84.1
14.3	1.71	0.65	0.42	971.3	83.9
14.4	1.72	0.65	0.42	971.0	83.7
14.5	1.73	0.66	0.43	970.8	83.5
14.5	1.74	0.66	0.43	970.5	83.4
14.6	1.74	0.66	0.43	970.3	83.2
14.6	1.75	0.66	0.43	970.0	83.0
14.7	1.76	0.66	0.43	969.8	82.8
14.7	1.76	0.67	0.43	969.5	82.6
14.8	1.77	0.67	0.43	969.3	82.4
14.9	1.78	0.67	0.43	969.0	82.2
14.9	1.78	0.67	0.44	968.8	82.0
15.0	1.79	0.68	0.44	968.5	81.8
15.0	1.80	0.68	0.44	968.3	81.7
15.1	1.81	0.68	0.44	968.0	81.5
15.2	1.81	0.68	0.44	967.8	81.3
15.2	1.82	0.68	0.44	967.5	81.1
15.3	1.83	0.69	0.44	967.3	80.9
15.3	1.83	0.69	0.44	967.0	80.7
15.4	1.84	0.69	0.45	966.8	80.5
15.5	1.85	0.69	0.45	966.5	80.3
15.5	1.86	0.70	0.45	966.3	80.1
15.6	1.86	0.70	0.45	966.0	79.9
15.6	1.87	0.70	0.45	965.7	79.7

Ødetail

15.7	1.88	0.70	0.45	965.5	79.5
15.8	1.88	0.70	0.45	965.2	79.3
15.8	1.89	0.71	0.45	965.0	79.1
15.9	1.90	0.71	0.46	964.7	78.9
15.9	1.91	0.71	0.46	964.4	78.7
16.0	1.91	0.71	0.46	964.2	78.5
16.0	1.92	0.72	0.46	963.9	78.3
16.1	1.93	0.72	0.46	963.6	78.1
16.2	1.93	0.72	0.46	963.4	77.9
16.2	1.94	0.72	0.46	963.1	77.7
16.3	1.95	0.72	0.46	962.8	77.5
16.3	1.96	0.73	0.47	962.6	77.3
16.4	1.96	0.73	0.47	962.3	77.1
16.5	1.97	0.73	0.47	962.0	76.9
16.5	1.98	0.98	0.61	961.7	76.7
16.6	1.98	0.99	0.61	961.4	76.5
16.6	1.99	0.99	0.62	961.0	76.2
16.7	2.00	0.99	0.62	960.7	76.0
16.8	2.01	1.00	0.62	960.3	75.7
16.8	2.01	1.00	0.62	959.9	75.5
16.9	2.02	1.00	0.62	959.5	75.2
16.9	2.03	1.01	0.62	959.2	74.9
17.0	2.04	1.01	0.63	958.8	74.7
17.1	2.05	1.01	0.63	958.4	74.4
17.1	2.05	1.02	0.63	958.0	74.1
17.2	2.06	1.02	0.63	957.7	73.9
17.2	2.07	1.02	0.63	957.3	73.6
17.3	2.08	1.03	0.64	956.9	73.4
17.3	2.08	1.03	0.64	956.5	73.1
17.4	2.09	1.03	0.64	956.1	72.8
17.5	2.10	1.04	0.64	955.8	72.6
17.5	2.11	1.04	0.64	955.4	72.3
17.6	2.11	1.04	0.65	955.0	72.0
17.6	2.12	1.05	0.65	954.6	71.8
17.7	2.13	1.05	0.65	954.2	71.5
17.8	2.14	1.05	0.65	953.8	71.2
17.8	2.15	1.06	0.65	953.4	70.9
17.9	2.15	1.06	0.66	953.0	70.7
17.9	2.16	1.06	0.66	952.7	70.4
18.0	2.17	1.07	0.66	952.3	70.1
18.1	2.18	1.07	0.66	951.9	69.9
18.1	2.18	1.07	0.66	951.5	69.6
18.2	2.19	1.08	0.67	951.1	69.3
18.2	2.20	1.08	0.67	950.7	69.0
18.3	2.21	1.08	0.67	950.3	68.8
18.4	2.21	1.09	0.67	949.9	68.5
18.4	2.22	1.09	0.67	949.5	68.2
18.5	2.23	1.09	0.67	949.1	67.9
18.5	2.24	1.10	0.68	948.6	67.6
18.6	2.25	1.10	0.68	948.2	67.4
18.6	2.25	1.10	0.68	947.8	67.1
18.7	2.26	1.11	0.68	947.4	66.8
18.8	2.27	1.11	0.68	947.0	66.5
18.8	2.28	1.11	0.69	946.6	66.2
18.9	2.28	1.12	0.69	946.2	66.0
18.9	2.29	1.12	0.69	945.8	65.7
19.0	2.30	1.12	0.69	945.4	65.4
19.1	2.31	1.13	0.69	944.9	65.1
19.1	2.31	1.13	0.70	944.5	64.8
19.2	2.32	1.13	0.70	944.1	64.5
19.2	2.33	1.14	0.70	943.7	64.2
19.3	2.34	1.14	0.70	943.3	64.0
19.4	2.35	1.14	0.70	942.8	63.7
19.4	2.35	1.15	0.71	942.4	63.4
19.5	2.36	1.15	0.71	942.0	63.1
19.5	2.37	1.15	0.71	941.6	62.8
19.6	2.38	1.16	0.71	941.1	62.5

Ødetail

19.7	2.38	1.16	0.71	940.7	62.2
19.7	2.39	1.16	0.72	940.3	61.9
19.8	2.40	1.17	0.72	939.8	61.6
19.8	2.41	1.17	0.72	939.4	61.3
19.9	2.41	1.17	0.72	939.0	61.0
19.9	2.42	1.18	0.72	938.5	60.7
20.0	2.43	1.18	0.72	938.1	60.4
20.1	2.44	1.18	0.73	937.7	60.1
20.1	2.45	1.19	0.73	937.2	59.8
20.2	2.45	1.19	0.73	936.8	59.5
20.2	2.46	1.19	0.73	936.3	59.2
20.3	2.47	1.20	0.73	935.9	58.9
20.4	2.48	1.20	0.74	935.4	58.6
20.4	2.48	1.20	0.74	935.0	58.3
20.5	2.49	1.21	0.74	934.5	58.0
20.5	2.50	1.21	0.74	934.1	57.7
20.6	2.51	1.21	0.74	933.7	57.4
20.7	2.51	1.22	0.75	933.2	57.1
20.7	2.52	1.22	0.75	932.7	56.8
20.8	2.53	1.22	0.75	932.3	56.5
20.8	2.54	1.23	0.75	931.8	56.2
20.9	2.55	1.23	0.75	931.4	55.9
21.0	2.55	1.23	0.76	930.9	55.6
21.0	2.56	1.24	0.76	930.5	55.3
21.1	2.57	1.24	0.76	930.0	55.0
21.1	2.58	1.24	0.76	929.5	54.7
21.2	2.58	1.25	0.76	929.1	54.3
21.3	2.59	1.25	0.77	928.6	54.0
21.3	2.60	1.25	0.77	928.2	53.7
21.4	2.61	1.26	0.77	927.7	53.4
21.4	2.61	1.26	0.77	927.2	53.1
21.5	2.62	1.26	0.77	926.8	52.8
21.5	2.63	1.27	0.77	926.3	52.5
21.6	2.64	1.27	0.78	925.8	52.1
21.7	2.65	1.27	0.78	925.3	51.8
21.7	2.65	1.28	0.78	924.9	51.5
21.8	2.66	1.28	0.78	924.4	51.2
21.8	2.67	1.28	0.78	923.9	50.9
21.9	2.68	1.29	0.79	923.4	50.6
22.0	2.68	1.29	0.79	923.0	50.2
22.0	2.69	1.29	0.79	922.5	49.9
22.1	2.70	1.30	0.79	922.0	49.6
22.1	2.71	1.30	0.79	921.5	49.3
22.2	2.71	1.30	0.80	921.0	48.9
22.3	2.72	1.31	0.80	920.6	48.6
22.3	2.73	1.31	0.80	920.1	48.3
22.4	2.74	1.31	0.80	919.6	48.0
22.4	2.75	1.32	0.80	919.1	47.6
22.5	2.75	1.32	0.81	918.6	47.3
22.6	2.76	1.32	0.81	918.1	47.0
22.6	2.77	1.33	0.81	917.6	46.7
22.7	2.78	1.33	0.81	917.1	46.3
22.7	2.78	1.33	0.81	916.6	46.0
22.8	2.79	1.34	0.82	916.1	45.7
22.8	2.80	1.34	0.82	915.6	45.3
22.9	2.81	1.35	0.82	915.1	45.0
23.0	2.81	1.35	0.82	914.6	44.7
23.0	2.82	1.35	0.82	914.1	44.3
23.1	2.83	1.36	0.82	913.6	44.0
23.1	2.84	1.36	0.83	913.1	43.7
23.2	2.84	1.36	0.83	912.6	43.3
23.3	2.85	1.37	0.83	912.1	43.0
23.3	2.86	1.37	0.83	911.6	42.7
23.4	2.87	1.37	0.83	911.1	42.3
23.4	2.88	1.38	0.84	910.6	42.0
23.5	2.88	1.38	0.84	910.1	41.7
23.6	2.89	1.38	0.84	909.6	41.3

Ødetail

23.6	2.90	1.39	0.84	909.1	41.0
23.7	2.91	1.39	0.84	908.5	40.6
23.7	2.91	1.39	0.85	908.0	40.3
23.8	2.92	1.40	0.85	907.5	39.9
23.9	2.93	1.40	0.85	907.0	39.6
23.9	2.94	1.40	0.85	906.5	39.3
24.0	2.94	1.41	0.85	906.0	38.9
24.0	2.95	1.41	0.86	905.4	38.6
24.1	2.96	1.41	0.86	904.9	38.2
24.1	2.97	1.42	0.86	904.4	37.9
24.2	2.98	1.42	0.86	903.9	37.5
24.3	2.98	1.42	0.86	903.3	37.2
24.3	2.99	1.43	0.87	902.8	36.8
24.4	3.00	1.43	0.87	902.3	36.5
24.4	3.01	1.43	0.87	901.7	36.1
24.5	3.01	1.44	0.87	901.2	35.8
24.6	3.02	1.44	0.87	900.7	35.4
24.6	3.03	1.44	0.87	900.1	35.1
24.7	3.04	1.45	0.88	899.6	34.7
24.7	3.04	1.45	0.88	899.1	34.4
24.8	3.05	1.45	0.88	898.5	34.0
24.9	3.06	1.46	0.88	898.0	33.7
24.9	3.07	1.46	0.88	897.5	33.3
25.0	3.08	1.46	0.89	896.9	32.9
25.0	3.08	1.47	0.89	896.4	32.6
25.1	3.09	1.47	0.89	895.8	32.2
25.2	3.10	1.47	0.89	895.3	31.9
25.2	3.11	1.48	0.89	894.7	31.5
25.3	3.11	1.48	0.90	894.2	31.1
25.3	3.12	1.48	0.90	893.6	30.8
25.4	3.13	1.49	0.90	893.1	30.4
25.4	3.14	1.49	0.90	892.5	30.1
25.5	3.14	1.49	0.90	892.0	29.7
25.6	3.15	1.50	0.91	891.4	29.3
25.6	3.16	1.50	0.91	890.9	29.0
25.7	3.17	1.50	0.91	890.3	28.6
25.7	3.18	1.51	0.91	889.7	28.2
25.8	3.18	1.51	0.91	889.2	27.9
25.9	3.19	1.51	0.91	888.6	27.5
25.9	3.20	1.52	0.92	888.1	27.1
26.0	3.21	1.52	0.92	887.5	26.8
26.0	3.21	1.52	0.92	886.9	26.4
26.1	3.22	1.53	0.92	886.4	26.0
26.2	3.23	1.53	0.92	885.8	25.7
26.2	3.24	1.53	0.93	885.2	25.3
26.3	3.24	1.54	0.93	884.7	24.9
26.3	3.25	1.54	0.93	884.1	24.5
26.4	3.26	1.54	0.93	883.5	24.2
26.5	3.27	1.55	0.93	883.0	23.8
26.5	3.28	1.55	0.94	882.4	23.4
26.6	3.28	1.55	0.94	881.8	23.0
26.6	3.29	1.56	0.94	881.2	22.7
26.7	3.30	1.56	0.94	880.6	22.3
26.7	3.31	1.56	0.94	880.1	21.9
26.8	3.31	1.57	0.95	879.5	21.5
26.9	3.32	1.57	0.95	878.9	21.1
26.9	3.33	1.57	0.95	878.3	20.8
27.0	3.34	1.58	0.95	877.7	20.4
27.0	3.34	1.58	0.95	877.2	20.0
27.1	3.35	1.58	0.96	876.6	19.6
27.2	3.36	1.59	0.96	876.0	19.2
27.2	3.37	1.59	0.96	875.4	18.9
27.3	3.38	1.59	0.96	874.8	18.5
27.3	3.38	1.60	0.96	874.2	18.1
27.4	3.39	1.60	0.96	873.6	17.7
27.5	3.40	1.60	0.97	873.0	17.3
27.5	3.41	1.61	0.97	872.4	16.9

Ødetail

27.6	3.41	1.61	0.97	871.8	16.5
27.6	3.42	1.61	0.97	871.2	16.1
27.7	3.43	1.62	0.97	870.6	15.8
27.8	3.44	1.62	0.98	870.0	15.4
27.8	3.44	1.62	0.98	869.4	15.0
27.9	3.45	1.63	0.98	868.8	14.6
27.9	3.46	1.63	0.98	868.2	14.2
28.0	3.47	1.63	0.98	867.6	13.8
28.0	3.48	1.64	0.99	867.0	13.4
28.1	3.48	1.64	0.99	866.4	13.0
28.2	3.49	1.64	0.99	865.8	12.6
28.2	3.50	1.65	0.99	865.2	12.2
28.3	3.51	1.65	0.99	864.6	11.8
28.3	3.51	1.65	1.00	863.9	11.4
28.4	3.52	1.66	1.00	863.3	11.0
28.5	3.53	1.66	1.00	862.7	10.6
28.5	3.54	1.66	1.00	862.1	10.2
28.6	3.54	1.67	1.00	861.5	9.8
28.6	3.55	1.67	1.01	860.9	9.4
28.7	3.56	1.67	1.01	860.2	9.0
28.8	3.57	1.68	1.01	859.6	8.6
28.8	3.58	1.68	1.01	859.0	8.2
28.9	3.58	1.68	1.01	858.4	7.8
28.9	3.59	1.69	1.01	857.7	7.4
29.0	3.60	1.69	1.02	857.1	7.0
29.1	3.61	1.69	1.02	856.5	6.6
29.1	3.61	1.70	1.02	855.9	6.2
29.2	3.62	1.70	1.02	855.2	5.8
29.2	3.63	1.70	1.02	854.6	5.4
29.3	3.64	1.71	1.03	854.0	5.0
29.3	3.64	1.71	1.03	853.3	4.6
29.4	3.65	1.71	1.03	852.7	4.1
29.5	3.66	1.72	1.03	852.1	3.7
29.5	3.67	1.72	1.03	851.4	3.3
29.6	3.67	1.72	1.04	850.8	2.9
29.6	3.68	1.73	1.04	850.1	2.5
29.7	3.69	1.73	1.04	849.5	2.1
29.8	3.70	1.73	1.04	848.9	1.7
29.8	3.71	1.74	1.04	848.2	1.3
29.9	3.71	1.74	1.05	847.6	0.8
29.9	3.72	1.75	1.05	846.9	0.4
30.0	3.73	1.75	1.05	846.3	0.0

Zs - Soil Depth, Depth from Ground Surface

Zp - Pile Depth, Depth from Pile Top

Sv - Vertical Effective Stress in Soils

Sf_dw - Uplift Side Resistance between Soil and Pile

Sf_up - Uplift Side Resistance between Soil and Pile

Q_dw - Downward Axial Force in Pile Shaft (Ultimate Uplift Capacity)

Q_up - Uplift Axial Force in Pile Shaft (Ultimate Uplift Capacity)

ULTIMATE CAPACITY vs FOUNDATION DEPTH

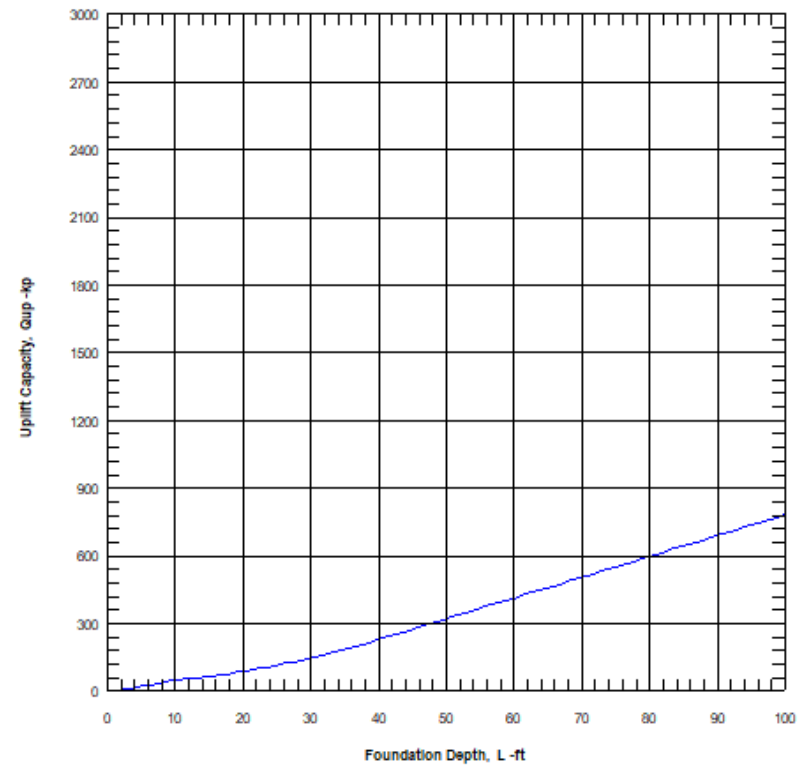
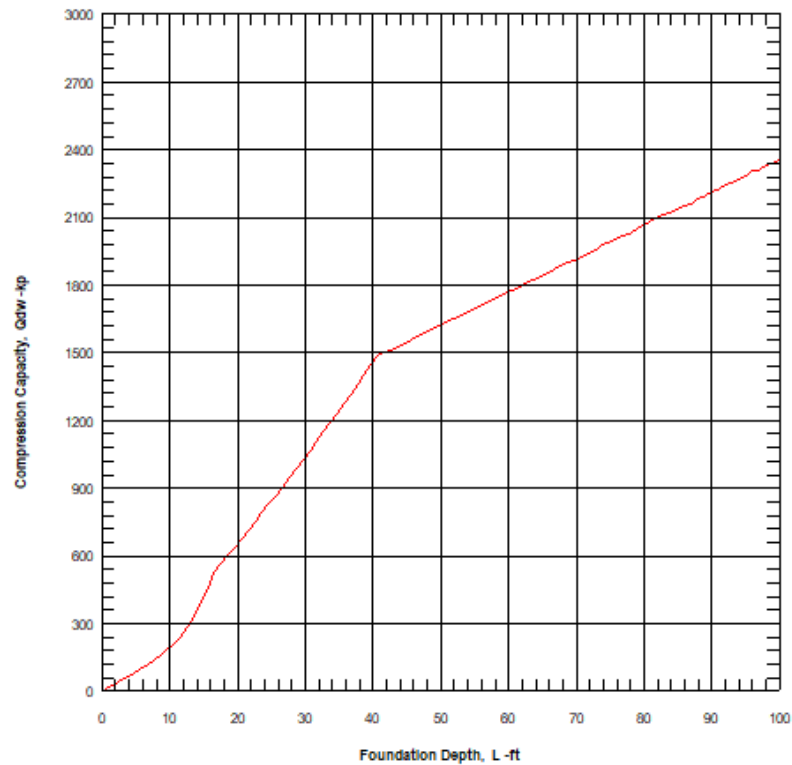

Downward and Uplift Capacity vs Pile Length

The results are for single section pile. Multiple sections may not be correct!

Length -ft	Qtip -kp	Qside -kp	Q_dw -kp	Qd_alw -kp	Weight -kp	Qsid* -kp	Q_up -kp	Qu_alw -kp
0.50	8.54	0.04	8.6	4.30	0.25	0.04	0.28	0.26
1.51	19.87	4.04	23.9	12.63	0.72	3.98	4.71	2.72
2.51	31.57	8.35	39.9	21.35	1.21	8.12	9.33	5.27
3.52	43.68	12.99	56.7	30.50	1.69	12.45	14.14	7.91
4.52	56.34	18.00	74.3	40.17	2.17	16.98	19.16	10.67
5.53	69.68	23.33	93.0	50.39	2.66	21.70	24.36	13.51
6.53	83.80	28.97	112.8	61.22	3.14	26.60	29.74	16.44
7.54	98.80	34.93	133.7	72.69	3.62	31.67	35.30	19.46
8.54	114.75	41.20	155.9	84.84	4.11	36.93	41.04	22.57
9.55	131.63	47.79	179.4	97.68	4.59	42.37	46.96	25.78
10.55	150.17	54.53	204.7	111.44	5.07	47.85	52.92	29.00
11.56	182.88	57.88	240.8	130.03	5.56	50.08	55.64	30.60
12.56	221.49	61.42	282.9	151.69	6.04	52.41	58.45	32.25
13.57	267.00	65.21	332.2	176.98	6.53	54.89	61.42	33.97
14.57	320.56	69.29	389.9	206.47	7.01	57.55	64.56	35.78
15.58	383.41	73.53	456.9	240.73	7.49	60.28	67.77	37.63
16.58	451.26	78.24	529.5	277.79	7.98	63.32	71.29	39.63
17.59	480.84	84.66	565.5	296.86	8.46	67.31	75.77	42.12
18.59	510.39	91.31	601.7	316.07	8.94	71.40	80.34	44.64
19.60	539.97	98.48	638.5	335.64	9.43	75.84	85.27	47.35
20.60	569.56	105.98	675.5	355.43	9.91	80.45	90.36	50.13
21.61	599.15	113.79	712.9	375.43	10.39	85.22	95.62	53.00
22.61	628.70	121.93	750.6	395.64	10.88	90.18	101.06	55.97
23.62	658.30	130.48	788.8	416.13	11.36	95.37	106.73	59.05
24.62	687.94	139.45	827.4	436.94	11.84	100.81	112.66	62.25
25.63	717.52	148.76	866.3	457.93	12.33	106.47	118.80	65.56
26.63	747.05	158.31	905.4	479.06	12.81	112.22	125.03	68.92
27.64	776.60	168.29	944.9	500.49	13.29	118.25	131.54	72.42
28.64	806.27	178.83	985.1	522.36	13.78	124.63	138.41	76.09
29.65	835.89	189.61	1025.5	544.35	14.26	131.12	145.38	79.82
30.65	865.45	200.61	1066.1	566.46	14.74	137.70	152.45	83.60
31.66	894.97	212.08	1107.1	588.87	15.23	144.60	159.83	87.53
32.66	924.55	223.89	1148.4	611.54	15.71	151.68	167.39	91.55
33.67	954.18	236.04	1190.2	634.45	16.19	158.91	175.11	95.65
34.67	983.79	248.68	1232.5	657.69	16.68	166.49	183.17	99.92
35.68	1013.36	261.38	1274.7	680.94	17.16	173.99	191.15	104.16
36.68	1042.89	274.57	1317.5	704.49	17.64	181.84	199.48	108.56
37.69	1072.53	288.41	1360.9	728.54	18.13	190.14	208.27	113.20
38.69	1101.96	302.13	1404.1	752.40	18.61	198.25	216.86	117.74
39.70	1131.69	316.69	1448.4	776.97	19.09	206.93	226.02	122.56
40.70	1154.16	331.42	1485.6	798.02	19.58	215.68	235.26	127.42
41.71	1154.46	346.27	1500.7	808.08	20.06	224.49	244.55	132.31
42.71	1153.18	360.89	1514.1	817.18	20.54	233.15	253.70	137.12
43.72	1153.24	375.71	1529.0	827.10	21.03	241.92	262.94	141.99
44.72	1154.44	390.38	1544.8	837.47	21.51	250.57	272.08	146.80
45.73	1154.57	405.39	1560.0	847.54	21.99	259.53	281.52	151.76
46.73	1153.44	419.91	1573.4	856.66	22.48	268.07	290.55	156.51
47.74	1153.82	434.70	1588.5	866.71	22.96	276.88	299.84	161.40
48.74	1153.39	449.65	1603.0	876.46	23.45	285.77	309.21	166.33
49.75	1154.59	464.54	1619.1	886.99	23.93	294.61	318.53	171.23
50.75	1155.09	479.59	1634.7	897.27	24.41	303.53	327.95	176.18
51.76	1154.43	494.26	1648.7	906.72	24.90	312.23	337.13	181.01
52.76	1152.85	508.79	1661.6	915.62	25.38	320.83	346.21	185.79
53.77	1153.48	523.61	1677.1	925.81	25.86	329.59	355.45	190.66
54.77	1153.04	538.02	1691.1	935.20	26.35	338.11	364.46	195.40
55.78	1155.42	553.64	1709.1	946.80	26.83	347.45	374.28	200.55
56.78	1153.67	568.03	1721.7	955.52	27.31	355.93	383.25	205.28
57.79	1154.36	583.13	1737.5	965.93	27.80	364.96	392.76	210.28
58.79	1154.47	597.86	1752.3	975.81	28.28	373.63	401.91	215.09
59.80	1153.77	612.65	1766.4	985.32	28.76	382.46	411.23	220.00

						ØLoad_L			
60.80	1152.23	626.70	1778.9	993.91	29.25	390.72	419.97	224.61	
61.81	1153.74	642.00	1795.7	1004.87	29.73	399.84	429.57	229.65	
62.81	1154.67	657.19	1811.9	1015.46	30.21	408.89	439.10	234.66	
63.82	1154.88	671.66	1826.5	1025.21	30.70	417.36	448.06	239.38	
64.82	1154.64	686.55	1841.2	1035.02	31.18	426.22	457.40	244.29	
65.83	1153.84	701.22	1855.1	1044.40	31.66	434.96	466.63	249.14	
66.83	1152.45	715.73	1868.2	1053.38	32.15	443.59	475.74	253.94	
67.84	1154.45	731.29	1885.7	1064.75	32.63	452.84	485.47	259.05	
68.84	1156.00	746.76	1902.8	1075.84	33.11	462.01	495.13	264.12	
69.85	1152.53	759.61	1912.1	1082.67	33.60	469.49	503.09	268.34	
70.85	1153.09	774.70	1927.8	1093.01	34.08	478.45	512.53	273.30	
71.86	1153.18	789.65	1942.8	1103.02	34.56	487.31	521.87	278.22	
72.86	1152.49	803.97	1956.5	1112.22	35.05	495.80	530.85	282.95	
73.87	1156.15	820.96	1977.1	1125.38	35.53	506.02	541.55	288.54	
74.87	1154.59	834.97	1989.6	1133.94	36.01	514.32	550.33	293.17	
75.88	1152.89	849.16	2002.1	1142.55	36.50	522.73	559.23	297.86	
76.88	1154.90	864.61	2019.5	1153.85	36.98	531.86	568.84	302.91	
77.89	1151.99	877.89	2029.9	1161.26	37.46	539.73	577.19	307.33	
78.89	1153.59	893.54	2047.1	1172.48	37.95	548.96	586.90	312.43	
79.90	1154.49	908.52	2063.0	1182.93	38.43	557.80	596.23	317.33	
80.90	1155.21	924.13	2079.3	1193.69	38.91	567.20	606.12	322.52	
81.91	1155.41	938.82	2094.2	1203.58	39.40	575.85	615.25	327.33	
82.91	1155.63	953.84	2109.5	1213.71	39.88	584.71	624.60	332.24	
83.92	1155.13	968.16	2123.3	1223.01	40.37	593.16	633.52	336.94	
84.92	1154.47	983.07	2137.5	1232.61	40.85	602.16	643.01	341.93	
85.93	1153.27	996.97	2150.2	1241.28	41.33	610.34	651.67	346.50	
86.93	1151.72	1010.61	2162.3	1249.60	41.82	618.38	660.20	351.01	
87.94	1155.17	1027.84	2183.0	1262.81	42.30	628.70	671.00	356.65	
88.94	1152.98	1041.07	2194.1	1270.54	42.78	636.51	679.29	361.04	
89.95	1155.71	1057.25	2213.0	1282.69	43.27	645.98	689.24	366.25	
90.95	1153.08	1070.94	2224.0	1290.50	43.75	654.26	698.01	370.88	
91.96	1155.29	1086.81	2242.1	1302.19	44.23	663.56	707.79	376.01	
92.96	1151.82	1099.11	2250.9	1308.65	44.72	670.81	715.52	380.12	
93.97	1153.71	1115.60	2269.3	1320.59	45.20	680.69	725.89	385.54	
94.97	1155.17	1131.04	2286.2	1331.61	45.68	689.73	735.41	390.55	
95.98	1156.61	1147.33	2303.9	1343.19	46.17	699.49	745.66	395.91	
96.98	1151.91	1158.64	2310.6	1348.38	46.65	706.16	752.81	399.73	
97.99	1152.84	1174.54	2327.4	1359.45	47.13	715.72	762.85	404.99	
98.99	1152.86	1188.61	2341.5	1368.84	47.62	723.93	771.55	409.58	
100.00	1153.32	1204.21	2357.5	1379.46	48.10	733.31	781.41	414.76	

FACTOR OF SAFETY:

FSSide	FStip	FSup	FSweight
1.5	2.0	2.0	1.0

Note: Data can be selected, copied and pasted to Excel to create graphics
 Length - Pile length, distance from pile top to tip (not from ground surface)
 Qtip - Ultimate pile tip resistance
 Qside - Ultimate pile side resistance
 Q_dw - Ultimate pile downward resistance
 Qd_alw - Allowable pile downward resistance
 Weight - Weight of pile shaft
 Qsid* - Ultimate pile side uplift resistance
 Q_up - Ultimate pile uplift resistance
 Qu_alw - Allowable pile uplift resistance

Vertical Load vs. Total Settlement

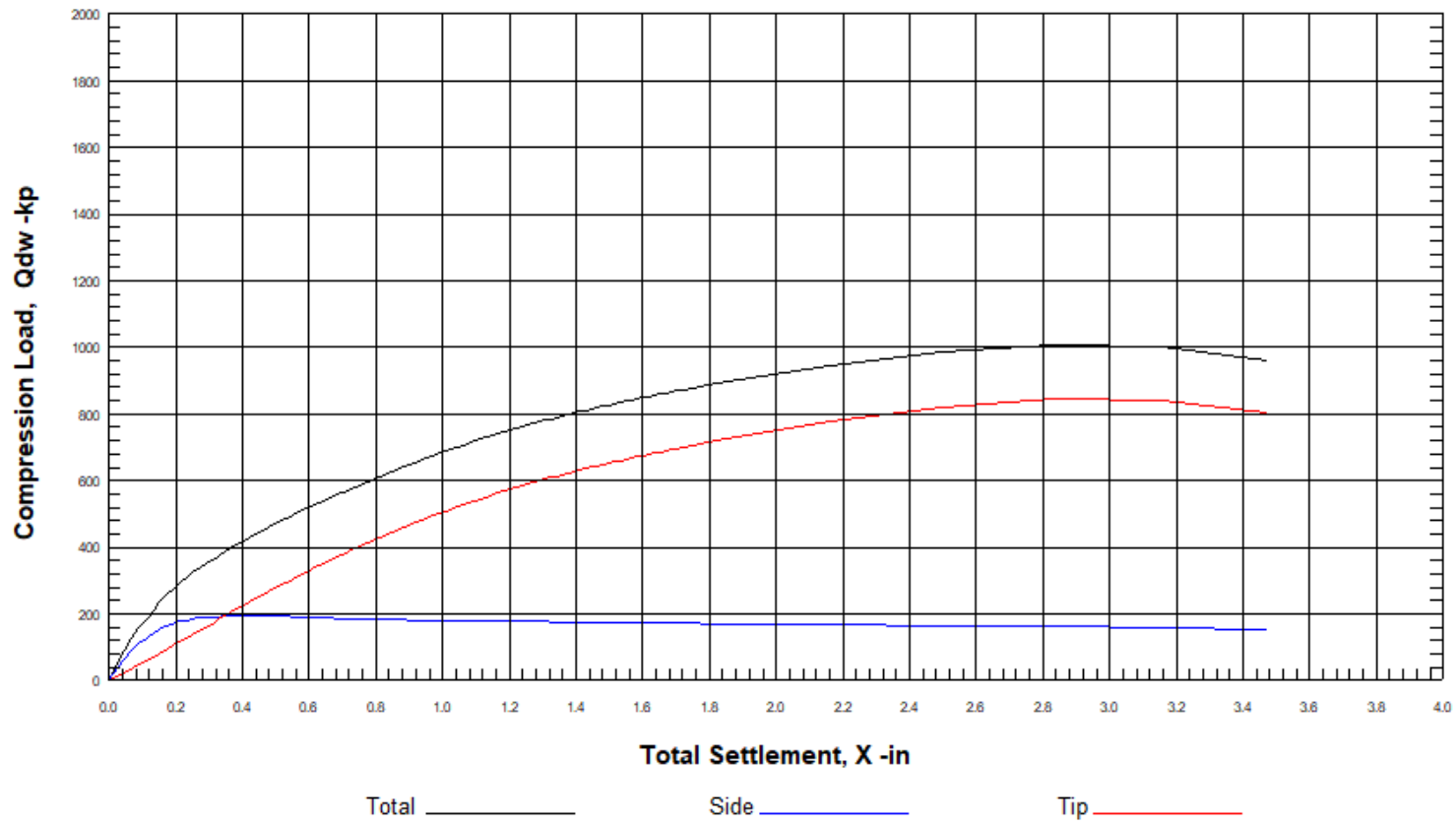

ØLoad_L

Vertical Side and Tip Resistance vs. Total Settlement:

Xtop -in	Qside -kp	Qtip -kp	Qtotal -kp
0.000	1.1	1.1	2.2
0.046	65.5	24.0	89.5
0.068	90.4	35.5	125.9
0.090	111.2	47.0	158.2
0.111	128.5	58.5	186.9
0.132	142.7	69.9	212.6
0.152	154.3	81.4	235.6
0.173	163.6	92.8	256.4
0.193	171.1	104.2	275.2
0.212	177.0	115.5	292.4
0.232	181.5	126.8	308.3
0.251	185.0	138.0	323.0
0.271	187.6	149.1	336.8
0.290	189.6	160.2	349.8
0.309	191.0	171.2	362.2
0.328	191.9	182.2	374.1
0.347	192.6	193.0	385.6
0.366	193.0	203.8	396.8
0.385	193.3	214.5	407.8
0.404	193.4	225.1	418.5
0.423	193.4	235.5	429.0
0.441	193.4	245.9	439.3
0.460	193.3	256.2	449.5
0.479	193.2	266.4	459.6
0.498	193.0	276.4	469.4
0.516	192.7	286.4	479.1
0.535	192.4	296.2	488.6
0.553	192.0	305.9	497.9
0.572	191.5	315.5	507.0
0.590	190.9	325.0	515.8
0.609	190.1	334.3	524.4
0.627	189.3	343.5	532.8
0.646	188.4	352.6	541.0
0.664	187.4	361.6	549.0
0.682	186.3	370.4	556.8
0.701	185.3	379.2	564.4
0.719	184.3	387.7	572.0
0.737	183.3	396.2	579.6
0.755	182.6	404.5	587.1
0.774	182.9	412.8	595.7
0.792	182.8	420.8	603.6
0.810	182.6	428.8	611.4
0.828	182.4	436.6	619.0
0.846	182.2	444.3	626.6
0.864	182.0	451.9	633.9
0.883	181.9	459.4	641.2
0.901	181.7	466.7	648.3
0.919	181.4	473.9	655.3
0.937	181.2	481.0	662.2
0.955	181.0	487.9	669.0
0.972	180.8	494.8	675.6
0.990	180.6	501.5	682.1
1.008	180.3	508.1	688.4
1.026	180.1	514.6	694.7
1.044	179.8	521.0	700.8
1.062	179.6	527.3	706.9
1.079	179.4	533.4	712.8
1.097	179.1	539.5	718.6

ØLoad_L

1.115	178.9	545.4	724.3
1.132	178.7	551.3	729.9
1.150	178.4	557.0	735.4
1.168	178.2	562.6	740.8
1.185	178.0	568.2	746.1
1.203	177.8	573.6	751.3
1.220	177.5	578.9	756.5
1.238	177.3	584.2	761.5
1.255	177.1	589.3	766.5
1.273	177.0	594.4	771.3
1.290	176.8	599.4	776.1
1.308	176.6	604.3	780.8
1.325	176.4	609.1	785.5
1.343	176.2	613.8	790.0
1.360	176.1	618.4	794.5
1.377	175.9	623.0	798.8
1.395	175.7	627.5	803.1
1.412	175.4	631.9	807.3
1.429	175.2	636.2	811.4
1.447	174.9	640.5	815.4
1.464	174.6	644.7	819.3
1.481	174.5	648.8	823.4
1.499	174.3	652.9	827.3
1.516	174.2	656.9	831.1
1.533	174.0	660.9	834.9
1.550	173.8	664.8	838.6
1.567	173.7	668.6	842.3
1.585	173.5	672.4	845.9
1.602	173.4	676.1	849.4
1.619	173.2	679.8	852.9
1.636	173.0	683.4	856.4
1.653	172.9	686.9	859.8
1.670	172.7	690.5	863.2
1.687	172.5	693.9	866.5
1.705	172.4	697.4	869.7
1.722	172.2	700.8	873.0
1.824	171.2	720.2	891.4
2.163	167.9	776.6	944.5
2.499	164.6	820.7	985.3
2.830	161.3	846.3	1007.5
3.155	158.0	842.7	1000.7
3.471	154.6	804.7	959.4

Xtop - Total Vertical Settlement
Qside - Vertical Side Resistance (Down)
Qtip - Vertical Tip Resistance (Down)
Qtotal - Vertical Total Resistance (Ultimate)

Side Resistance vs. Relative Movement between Soil and Shaft (t-z)



Soil Depth (Zs): 3.7, 7.4, 11.1, 14.8, 18.4, 22.1, 25.8 -ft



ØLoad_L

Side Resistance vs. Relative Movement between Soil and Shaft (t-z)

Zs -ft	t -kp/f2	z -in
3.69	0.00	0.00
3.69	0.27	0.03
3.69	0.38	0.04
3.69	0.46	0.06
3.69	0.53	0.07
3.69	0.59	0.09
3.69	0.64	0.10
3.69	0.67	0.11
3.69	0.70	0.13
3.69	0.72	0.14
3.69	0.74	0.16
3.69	0.76	0.17
3.69	0.77	0.18
3.69	0.77	0.20
3.69	0.78	0.21
3.69	0.78	0.23
3.69	0.78	0.24
3.69	0.78	0.26
3.69	0.78	0.27
3.69	0.78	0.28
3.69	0.78	0.30
3.69	0.78	0.31
3.69	0.78	0.33
3.69	0.78	0.34
3.69	0.78	0.35
3.69	0.78	0.37
3.69	0.78	0.38
3.69	0.78	0.40
3.69	0.77	0.41
3.69	0.77	0.43
3.69	0.77	0.44
3.69	0.76	0.45
3.69	0.76	0.47
3.69	0.76	0.48
3.69	0.75	0.50
3.69	0.75	0.51
3.69	0.74	0.53
3.69	0.74	0.54
3.69	0.73	0.55
3.69	0.74	0.57
3.69	0.73	0.58
3.69	0.73	0.60
3.69	0.73	0.61
3.69	0.73	0.62
3.69	0.73	0.64
3.69	0.73	0.65
3.69	0.73	0.67
3.69	0.73	0.68
3.69	0.73	0.70
3.69	0.73	0.71
3.69	0.73	0.72
3.69	0.73	0.74
3.69	0.73	0.75
3.69	0.73	0.77
3.69	0.73	0.78
3.69	0.72	0.79
3.69	0.72	0.81
3.69	0.72	0.82

0Load_L

3.69	0.72	0.84
3.69	0.72	0.85
3.69	0.72	0.87
3.69	0.72	0.88
3.69	0.72	0.89
3.69	0.72	0.91
3.69	0.72	0.92
3.69	0.72	0.94
3.69	0.72	0.95
3.69	0.72	0.96
3.69	0.72	0.98
3.69	0.72	0.99
3.69	0.71	1.01
3.69	0.71	1.02
3.69	0.71	1.04
3.69	0.71	1.05
3.69	0.71	1.06
3.69	0.71	1.08
3.69	0.71	1.09
3.69	0.71	1.11
3.69	0.71	1.12
3.69	0.71	1.14
3.69	0.71	1.15
3.69	0.71	1.16
3.69	0.71	1.18
3.69	0.71	1.19
3.69	0.71	1.21
3.69	0.70	1.22
3.69	0.70	1.23
3.69	0.70	1.25
3.69	0.70	1.26
3.69	0.70	1.28
3.69	0.70	1.29
3.69	0.70	1.31
3.69	0.70	1.32
3.69	0.70	1.33
3.69	0.70	1.42
3.69	0.68	1.70
3.69	0.67	1.99
3.69	0.66	2.27
3.69	0.64	2.55
3.69	0.63	2.84

Zs	t	z
-ft	-kp/f2	-in
7.38	0.01	0.00
7.38	0.33	0.03
7.38	0.46	0.04
7.38	0.57	0.06
7.38	0.65	0.07
7.38	0.72	0.09
7.38	0.78	0.10
7.38	0.83	0.11
7.38	0.86	0.13
7.38	0.89	0.14
7.38	0.91	0.16
7.38	0.93	0.17
7.38	0.94	0.18
7.38	0.95	0.20
7.38	0.95	0.21
7.38	0.96	0.23
7.38	0.96	0.24
7.38	0.96	0.26
7.38	0.96	0.27
7.38	0.96	0.28
7.38	0.96	0.30

ØLoad_L

7.38	0.96	0.31
7.38	0.96	0.33
7.38	0.96	0.34
7.38	0.96	0.35
7.38	0.96	0.37
7.38	0.96	0.38
7.38	0.95	0.40
7.38	0.95	0.41
7.38	0.95	0.43
7.38	0.94	0.44
7.38	0.94	0.45
7.38	0.93	0.47
7.38	0.93	0.48
7.38	0.92	0.50
7.38	0.92	0.51
7.38	0.91	0.53
7.38	0.90	0.54
7.38	0.90	0.55
7.38	0.90	0.57
7.38	0.90	0.58
7.38	0.90	0.60
7.38	0.90	0.61
7.38	0.90	0.62
7.38	0.90	0.64
7.38	0.90	0.65
7.38	0.90	0.67
7.38	0.90	0.68
7.38	0.90	0.70
7.38	0.89	0.71
7.38	0.89	0.72
7.38	0.89	0.74
7.38	0.89	0.75
7.38	0.89	0.77
7.38	0.89	0.78
7.38	0.89	0.79
7.38	0.89	0.81
7.38	0.89	0.82
7.38	0.89	0.84
7.38	0.89	0.85
7.38	0.89	0.87
7.38	0.88	0.88
7.38	0.88	0.89
7.38	0.88	0.91
7.38	0.88	0.92
7.38	0.88	0.94
7.38	0.88	0.95
7.38	0.88	0.96
7.38	0.88	0.98
7.38	0.88	0.99
7.38	0.88	1.01
7.38	0.88	1.02
7.38	0.88	1.04
7.38	0.87	1.05
7.38	0.87	1.06
7.38	0.87	1.08
7.38	0.87	1.09
7.38	0.87	1.11
7.38	0.87	1.12
7.38	0.87	1.14
7.38	0.87	1.15
7.38	0.87	1.16
7.38	0.87	1.18
7.38	0.87	1.19
7.38	0.87	1.21
7.38	0.86	1.22
7.38	0.86	1.23
7.38	0.86	1.25

ØLoad_L

7.38	0.86	1.26
7.38	0.86	1.28
7.38	0.86	1.29
7.38	0.86	1.31
7.38	0.86	1.32
7.38	0.86	1.33
7.38	0.85	1.42
7.38	0.84	1.70
7.38	0.82	1.99
7.38	0.80	2.27
7.38	0.79	2.55
7.38	0.77	2.84

Zs	t	z
-ft	-kp/f2	-in
11.06	0.00	0.00
11.06	0.15	0.03
11.06	0.21	0.04
11.06	0.26	0.06
11.06	0.31	0.07
11.06	0.35	0.09
11.06	0.38	0.10
11.06	0.41	0.11
11.06	0.43	0.13
11.06	0.46	0.14
11.06	0.47	0.16
11.06	0.49	0.17
11.06	0.50	0.18
11.06	0.51	0.20
11.06	0.52	0.21
11.06	0.52	0.23
11.06	0.53	0.24
11.06	0.53	0.26
11.06	0.54	0.27
11.06	0.54	0.28
11.06	0.54	0.30
11.06	0.54	0.31
11.06	0.54	0.33
11.06	0.54	0.34
11.06	0.54	0.35
11.06	0.54	0.37
11.06	0.54	0.38
11.06	0.54	0.40
11.06	0.54	0.41
11.06	0.54	0.43
11.06	0.54	0.44
11.06	0.54	0.45
11.06	0.54	0.47
11.06	0.54	0.48
11.06	0.54	0.50
11.06	0.54	0.51
11.06	0.54	0.53
11.06	0.54	0.54
11.06	0.54	0.55
11.06	0.54	0.57
11.06	0.54	0.58
11.06	0.54	0.60
11.06	0.54	0.61
11.06	0.54	0.62
11.06	0.54	0.64
11.06	0.54	0.65
11.06	0.53	0.67
11.06	0.53	0.68
11.06	0.53	0.70
11.06	0.53	0.71
11.06	0.53	0.72

ØLoad_L

11.06	0.53	0.74
11.06	0.52	0.75
11.06	0.52	0.77
11.06	0.52	0.78
11.06	0.52	0.79
11.06	0.52	0.81
11.06	0.51	0.82
11.06	0.51	0.84
11.06	0.51	0.85
11.06	0.51	0.87
11.06	0.50	0.88
11.06	0.50	0.89
11.06	0.50	0.91
11.06	0.50	0.92
11.06	0.50	0.94
11.06	0.50	0.95
11.06	0.50	0.96
11.06	0.50	0.98
11.06	0.49	0.99
11.06	0.49	1.01
11.06	0.49	1.02
11.06	0.49	1.04
11.06	0.49	1.05
11.06	0.49	1.06
11.06	0.49	1.08
11.06	0.49	1.09
11.06	0.48	1.11
11.06	0.48	1.12
11.06	0.48	1.14
11.06	0.48	1.15
11.06	0.48	1.16
11.06	0.48	1.18
11.06	0.48	1.19
11.06	0.48	1.21
11.06	0.48	1.22
11.06	0.48	1.23
11.06	0.48	1.25
11.06	0.48	1.26
11.06	0.47	1.28
11.06	0.47	1.29
11.06	0.47	1.31
11.06	0.47	1.32
11.06	0.47	1.33
11.06	0.47	1.42
11.06	0.46	1.70
11.06	0.45	1.99
11.06	0.44	2.27
11.06	0.43	2.55
11.06	0.42	2.84

Zs	t	z
-ft	-kp/f2	-in

14.75	0.00	0.00
14.75	0.18	0.03
14.75	0.26	0.04
14.75	0.33	0.06
14.75	0.38	0.07
14.75	0.43	0.09
14.75	0.48	0.10
14.75	0.51	0.11
14.75	0.54	0.13
14.75	0.57	0.14
14.75	0.59	0.16
14.75	0.61	0.17
14.75	0.63	0.18
14.75	0.64	0.20

ØLoad_L

14.75	0.65	0.21
14.75	0.66	0.23
14.75	0.66	0.24
14.75	0.67	0.26
14.75	0.67	0.27
14.75	0.67	0.28
14.75	0.68	0.30
14.75	0.68	0.31
14.75	0.68	0.33
14.75	0.68	0.34
14.75	0.68	0.35
14.75	0.68	0.37
14.75	0.68	0.38
14.75	0.68	0.40
14.75	0.68	0.41
14.75	0.68	0.43
14.75	0.68	0.44
14.75	0.68	0.45
14.75	0.68	0.47
14.75	0.68	0.48
14.75	0.68	0.50
14.75	0.68	0.51
14.75	0.68	0.53
14.75	0.68	0.54
14.75	0.68	0.55
14.75	0.68	0.57
14.75	0.68	0.58
14.75	0.67	0.60
14.75	0.67	0.61
14.75	0.67	0.62
14.75	0.67	0.64
14.75	0.67	0.65
14.75	0.67	0.67
14.75	0.67	0.68
14.75	0.66	0.70
14.75	0.66	0.71
14.75	0.66	0.72
14.75	0.66	0.74
14.75	0.65	0.75
14.75	0.65	0.77
14.75	0.65	0.78
14.75	0.65	0.79
14.75	0.64	0.81
14.75	0.64	0.82
14.75	0.64	0.84
14.75	0.64	0.85
14.75	0.63	0.87
14.75	0.63	0.88
14.75	0.63	0.89
14.75	0.63	0.91
14.75	0.62	0.92
14.75	0.62	0.94
14.75	0.62	0.95
14.75	0.62	0.96
14.75	0.62	0.98
14.75	0.62	0.99
14.75	0.62	1.01
14.75	0.62	1.02
14.75	0.61	1.04
14.75	0.61	1.05
14.75	0.61	1.06
14.75	0.61	1.08
14.75	0.61	1.09
14.75	0.60	1.11
14.75	0.60	1.12
14.75	0.60	1.14
14.75	0.60	1.15

ØLoad_L

14.75	0.60	1.16
14.75	0.60	1.18
14.75	0.60	1.19
14.75	0.60	1.21
14.75	0.60	1.22
14.75	0.60	1.23
14.75	0.59	1.25
14.75	0.59	1.26
14.75	0.59	1.28
14.75	0.59	1.29
14.75	0.59	1.31
14.75	0.59	1.32
14.75	0.59	1.33
14.75	0.59	1.42
14.75	0.58	1.70
14.75	0.56	1.99
14.75	0.55	2.27
14.75	0.54	2.55
14.75	0.53	2.84

Zs	t	z
-ft	-kp/f2	-in
18.44	0.01	0.00
18.44	0.38	0.03
18.44	0.52	0.04
18.44	0.64	0.06
18.44	0.74	0.07
18.44	0.82	0.09
18.44	0.88	0.10
18.44	0.94	0.11
18.44	0.98	0.13
18.44	1.01	0.14
18.44	1.03	0.16
18.44	1.05	0.17
18.44	1.07	0.18
18.44	1.07	0.20
18.44	1.08	0.21
18.44	1.09	0.23
18.44	1.09	0.24
18.44	1.09	0.26
18.44	1.09	0.27
18.44	1.09	0.28
18.44	1.09	0.30
18.44	1.09	0.31
18.44	1.09	0.33
18.44	1.09	0.34
18.44	1.09	0.35
18.44	1.09	0.37
18.44	1.08	0.38
18.44	1.08	0.40
18.44	1.08	0.41
18.44	1.07	0.43
18.44	1.07	0.44
18.44	1.06	0.45
18.44	1.06	0.47
18.44	1.05	0.48
18.44	1.05	0.50
18.44	1.04	0.51
18.44	1.03	0.53
18.44	1.03	0.54
18.44	1.02	0.55
18.44	1.02	0.57
18.44	1.02	0.58
18.44	1.02	0.60
18.44	1.02	0.61
18.44	1.02	0.62

ØLoad_L

18.44	1.02	0.64
18.44	1.02	0.65
18.44	1.02	0.67
18.44	1.02	0.68
18.44	1.02	0.70
18.44	1.01	0.71
18.44	1.01	0.72
18.44	1.01	0.74
18.44	1.01	0.75
18.44	1.01	0.77
18.44	1.01	0.78
18.44	1.01	0.79
18.44	1.01	0.81
18.44	1.01	0.82
18.44	1.01	0.84
18.44	1.01	0.85
18.44	1.00	0.87
18.44	1.00	0.88
18.44	1.00	0.89
18.44	1.00	0.91
18.44	1.00	0.92
18.44	1.00	0.94
18.44	1.00	0.95
18.44	1.00	0.96
18.44	1.00	0.98
18.44	1.00	0.99
18.44	0.99	1.01
18.44	0.99	1.02
18.44	0.99	1.04
18.44	0.99	1.05
18.44	0.99	1.06
18.44	0.99	1.08
18.44	0.99	1.09
18.44	0.99	1.11
18.44	0.99	1.12
18.44	0.99	1.14
18.44	0.99	1.15
18.44	0.98	1.16
18.44	0.98	1.18
18.44	0.98	1.19
18.44	0.98	1.21
18.44	0.98	1.22
18.44	0.98	1.23
18.44	0.98	1.25
18.44	0.98	1.26
18.44	0.98	1.28
18.44	0.98	1.29
18.44	0.98	1.31
18.44	0.97	1.32
18.44	0.97	1.33
18.44	0.97	1.42
18.44	0.95	1.70
18.44	0.93	1.99
18.44	0.91	2.27
18.44	0.89	2.55
18.44	0.88	2.84

Zs	t	z
-ft	-kp/f2	-in
22.13	0.01	0.00
22.13	0.45	0.03
22.13	0.62	0.04
22.13	0.76	0.06
22.13	0.88	0.07
22.13	0.97	0.09
22.13	1.05	0.10

ØLoad_L

22.13	1.11	0.11
22.13	1.16	0.13
22.13	1.20	0.14
22.13	1.23	0.16
22.13	1.25	0.17
22.13	1.27	0.18
22.13	1.28	0.20
22.13	1.29	0.21
22.13	1.29	0.23
22.13	1.30	0.24
22.13	1.30	0.26
22.13	1.30	0.27
22.13	1.30	0.28
22.13	1.30	0.30
22.13	1.30	0.31
22.13	1.30	0.33
22.13	1.30	0.34
22.13	1.29	0.35
22.13	1.29	0.37
22.13	1.29	0.38
22.13	1.29	0.40
22.13	1.28	0.41
22.13	1.28	0.43
22.13	1.27	0.44
22.13	1.27	0.45
22.13	1.26	0.47
22.13	1.25	0.48
22.13	1.24	0.50
22.13	1.24	0.51
22.13	1.23	0.53
22.13	1.22	0.54
22.13	1.22	0.55
22.13	1.22	0.57
22.13	1.22	0.58
22.13	1.22	0.60
22.13	1.21	0.61
22.13	1.21	0.62
22.13	1.21	0.64
22.13	1.21	0.65
22.13	1.21	0.67
22.13	1.21	0.68
22.13	1.21	0.70
22.13	1.21	0.71
22.13	1.21	0.72
22.13	1.20	0.74
22.13	1.20	0.75
22.13	1.20	0.77
22.13	1.20	0.78
22.13	1.20	0.79
22.13	1.20	0.81
22.13	1.20	0.82
22.13	1.20	0.84
22.13	1.20	0.85
22.13	1.19	0.87
22.13	1.19	0.88
22.13	1.19	0.89
22.13	1.19	0.91
22.13	1.19	0.92
22.13	1.19	0.94
22.13	1.19	0.95
22.13	1.19	0.96
22.13	1.19	0.98
22.13	1.18	0.99
22.13	1.18	1.01
22.13	1.18	1.02
22.13	1.18	1.04
22.13	1.18	1.05

ØLoad_L

22.13	1.18	1.06
22.13	1.18	1.08
22.13	1.18	1.09
22.13	1.18	1.11
22.13	1.17	1.12
22.13	1.17	1.14
22.13	1.17	1.15
22.13	1.17	1.16
22.13	1.17	1.18
22.13	1.17	1.19
22.13	1.17	1.21
22.13	1.17	1.22
22.13	1.17	1.23
22.13	1.16	1.25
22.13	1.16	1.26
22.13	1.16	1.28
22.13	1.16	1.29
22.13	1.16	1.31
22.13	1.16	1.32
22.13	1.16	1.33
22.13	1.15	1.42
22.13	1.13	1.70
22.13	1.11	1.99
22.13	1.09	2.27
22.13	1.06	2.55
22.13	1.04	2.84

Zs	t	z
-ft	-kp/f2	-in
25.81	0.01	0.00
25.81	0.52	0.03
25.81	0.72	0.04
25.81	0.88	0.06
25.81	1.02	0.07
25.81	1.13	0.09
25.81	1.22	0.10
25.81	1.29	0.11
25.81	1.34	0.13
25.81	1.39	0.14
25.81	1.42	0.16
25.81	1.45	0.17
25.81	1.47	0.18
25.81	1.48	0.20
25.81	1.49	0.21
25.81	1.49	0.23
25.81	1.50	0.24
25.81	1.50	0.26
25.81	1.50	0.27
25.81	1.50	0.28
25.81	1.50	0.30
25.81	1.50	0.31
25.81	1.50	0.33
25.81	1.50	0.34
25.81	1.50	0.35
25.81	1.49	0.37
25.81	1.49	0.38
25.81	1.49	0.40
25.81	1.48	0.41
25.81	1.48	0.43
25.81	1.47	0.44
25.81	1.46	0.45
25.81	1.46	0.47
25.81	1.45	0.48
25.81	1.44	0.50
25.81	1.43	0.51
25.81	1.42	0.53

ØLoad_L

25.81	1.41	0.54
25.81	1.41	0.55
25.81	1.41	0.57
25.81	1.41	0.58
25.81	1.41	0.60
25.81	1.40	0.61
25.81	1.40	0.62
25.81	1.40	0.64
25.81	1.40	0.65
25.81	1.40	0.67
25.81	1.40	0.68
25.81	1.40	0.70
25.81	1.40	0.71
25.81	1.39	0.72
25.81	1.39	0.74
25.81	1.39	0.75
25.81	1.39	0.77
25.81	1.39	0.78
25.81	1.39	0.79
25.81	1.39	0.81
25.81	1.39	0.82
25.81	1.38	0.84
25.81	1.38	0.85
25.81	1.38	0.87
25.81	1.38	0.88
25.81	1.38	0.89
25.81	1.38	0.91
25.81	1.38	0.92
25.81	1.38	0.94
25.81	1.37	0.95
25.81	1.37	0.96
25.81	1.37	0.98
25.81	1.37	0.99
25.81	1.37	1.01
25.81	1.37	1.02
25.81	1.37	1.04
25.81	1.37	1.05
25.81	1.36	1.06
25.81	1.36	1.08
25.81	1.36	1.09
25.81	1.36	1.11
25.81	1.36	1.12
25.81	1.36	1.14
25.81	1.36	1.15
25.81	1.36	1.16
25.81	1.35	1.18
25.81	1.35	1.19
25.81	1.35	1.21
25.81	1.35	1.22
25.81	1.35	1.23
25.81	1.35	1.25
25.81	1.35	1.26
25.81	1.35	1.28
25.81	1.34	1.29
25.81	1.34	1.31
25.81	1.34	1.32
25.81	1.34	1.33
25.81	1.33	1.42
25.81	1.31	1.70
25.81	1.28	1.99
25.81	1.26	2.27
25.81	1.23	2.55
25.81	1.20	2.84

Zs - Depth from Soil Top
t - Side Resistance
z - Relative Movement between Soil and Shaft

0Load_L

Tip Resistance vs. Tip Movement (q-w)

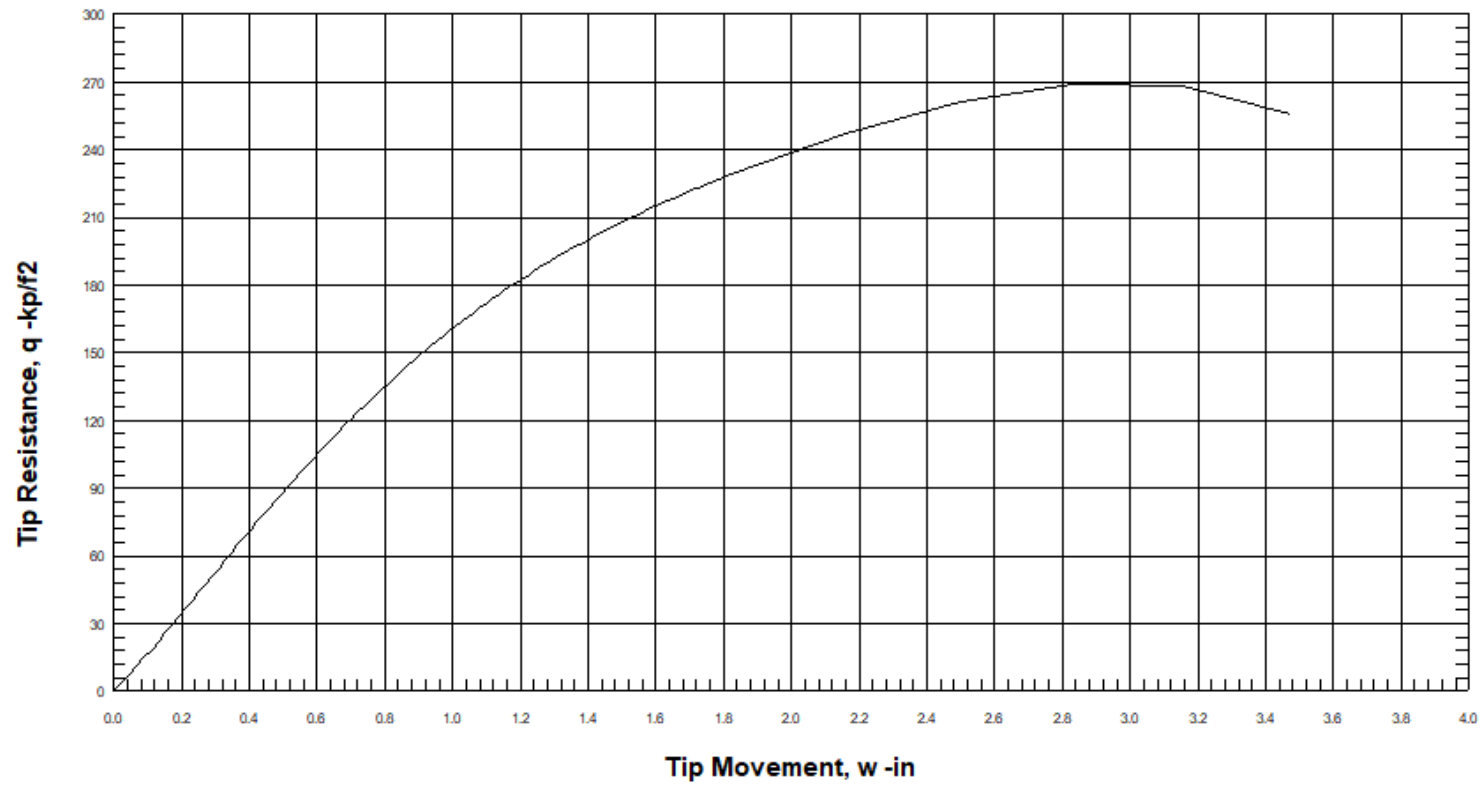

Tip Resistance vs. Tip Movement (q-w)

Depth of Pile Tip from Ground Surface = 29.50-ft

q -kp/f2	w -in
0.36	0.00
7.65	0.05
11.31	0.07
14.96	0.09
18.61	0.11
22.26	0.13
25.90	0.15
29.53	0.17
33.15	0.19
36.76	0.21
40.35	0.23
43.92	0.25
47.47	0.27
51.00	0.29
54.51	0.31
57.99	0.33
61.45	0.35
64.87	0.37
68.27	0.38
71.64	0.40
74.98	0.42
78.28	0.44
81.55	0.46
84.79	0.48
87.99	0.50
91.15	0.52
94.28	0.53
97.37	0.55
100.42	0.57
103.43	0.59
106.41	0.61
109.34	0.63
112.24	0.65
115.10	0.66
117.91	0.68
120.69	0.70
123.42	0.72
126.11	0.74
128.77	0.76
131.38	0.77
133.95	0.79
136.49	0.81
138.98	0.83
141.43	0.85
143.84	0.86
146.21	0.88
148.55	0.90
150.84	0.92
153.09	0.94
155.31	0.95
157.49	0.97
159.63	0.99
161.74	1.01
163.80	1.03
165.83	1.04
167.83	1.06
169.79	1.08

ØLoad_L

171.72	1.10
173.61	1.11
175.47	1.13
177.29	1.15
179.08	1.17
180.85	1.19
182.58	1.20
184.27	1.22
185.94	1.24
187.58	1.26
189.20	1.27
190.78	1.29
192.34	1.31
193.86	1.33
195.37	1.34
196.85	1.36
198.30	1.38
199.73	1.39
201.13	1.41
202.51	1.43
203.87	1.45
205.21	1.46
206.53	1.48
207.82	1.50
209.10	1.52
210.36	1.53
211.59	1.55
212.81	1.57
214.02	1.58
215.20	1.60
216.37	1.62
217.52	1.64
218.66	1.65
219.78	1.67
220.88	1.69
221.97	1.70
223.05	1.72
229.25	1.82
247.21	2.16
261.24	2.50
269.37	2.83
268.25	3.15
256.15	3.47

q - Tip Resistance
w - Tip Movement

LATERAL ANALYSIS

Figure 2

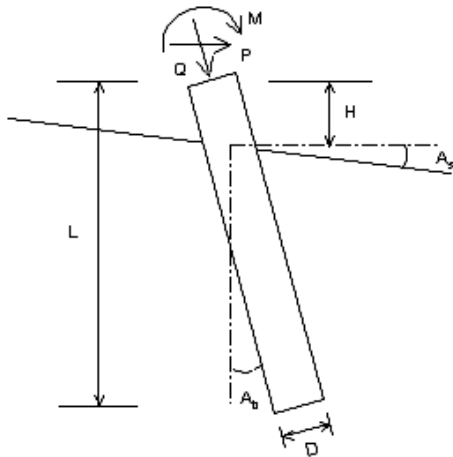

Drilled Pile (dia \leq 24 in. or 61 cm)

Loads:

Load Factor for Vertical Loads= 1.0
 Load Factor for Lateral Loads= 1.0
 Loads Supported by Pile Cap= 0 %
 Shear Condition: Static

(with Load Factor)

Vertical Load, Q= 460.0 -kp
 Shear Load, P= 40.0 -kp
 Slope Restrain St= 0.00000 -in/-in

Profile:

Pile Length, L= 25.0 -ft
 Top Height, H= .5 -ft
 Slope Angle, As= 24.0
 Batter Angle, Ab= 0
 Fixed Head Condition

Soil Data:

Depth -ft	Gamma -lb/f3	Phi	C -kp/f2	K -lb/i3	e50 or Dr %	Nspt
0	125	37.0	.75	122.7	57.53	23
10	120	30	.1	331.6	.85	10
16	130	40	.1	278	85.61	50

Pile Data:

Depth -ft	Width -in	Area -in2	Per. -in %	I -in4	E -kp/i2	Weight -kp/f
0.0	24	482.9	75.4	16298.3	3000	0.479
3.0	24	482.9	75.4	16298.3	3000	0.479
25.0						

Single Pile Lateral Analysis:

Top Deflection, yt= 0.27200-in
 Max. Moment, M= -226.67-kp-f
 Top Deflection Slope, St= 0.00000
 OK! Top Deflection, 0.2720-in is less than the Allowable Deflection= 1.00-in

Note: If the program cannot find a result or the result exceeds the upper limit. The result will be displayed as 99999.
 The Max. Moment calculated by program is an internal force from the applied load conditions. Structural engineer has to check whether the pile has enough capacity to resist the moment with adequate factor of safety. If not, the pile may fail under the load conditions.



**CivilTech
Software**

**Lot 44
Foundations P9 & P10**

Øsummary

ALLPILE 7
LATERAL ANALYSIS SUMMARY OUTPUT
Copyright by CivilTech Software
www.civiltech.com

FACTORS AND CONDITIONS:

Load Factor for Vertical Loads: 1.0
Load Factor for Lateral Loads: 1.0
Loads Supported by Pile Cap: 0 %
Shear Condition: Static

SINGLE PILE:

(with Load Factor)
Vertical Load= 460.00 -kp
Shear= 40.00 -kp
Slope Restrain, St= 0.00 -in/-in

Results:

Top Deflection, yt= 0.27200-in
Max. Moment, M= -226.67-kp-f
Top Deflection Slope, St= 0.00000

Top Deflection, 0.2720-in, OK with the Allowable Deflection= 1.00-in

Note: If the program cannot find a result or the result exceeds the upper limit. The result will be displayed as 99999.

Notes:

Q - Vertical Load at pile top
P - Lateral Shear Load at pile top
M - Moment at pile top
Xtop - Pile top total settlement
yt - Pile top deflection
St - Pile top deflection slope (deflection/unit length)

The Max. Moment calculated by program is an internal moment of shaft due to the loading. Engineers have to check whether the pile has enough moment capacity to resist the Max. Moment with adequate factor of safety. If not, the pile may be damaged under the loading.

1 1 1 1 1

PILE DEFLECTION & FORCE vs DEPTH Single Pile, Khead=5, Kbc=2

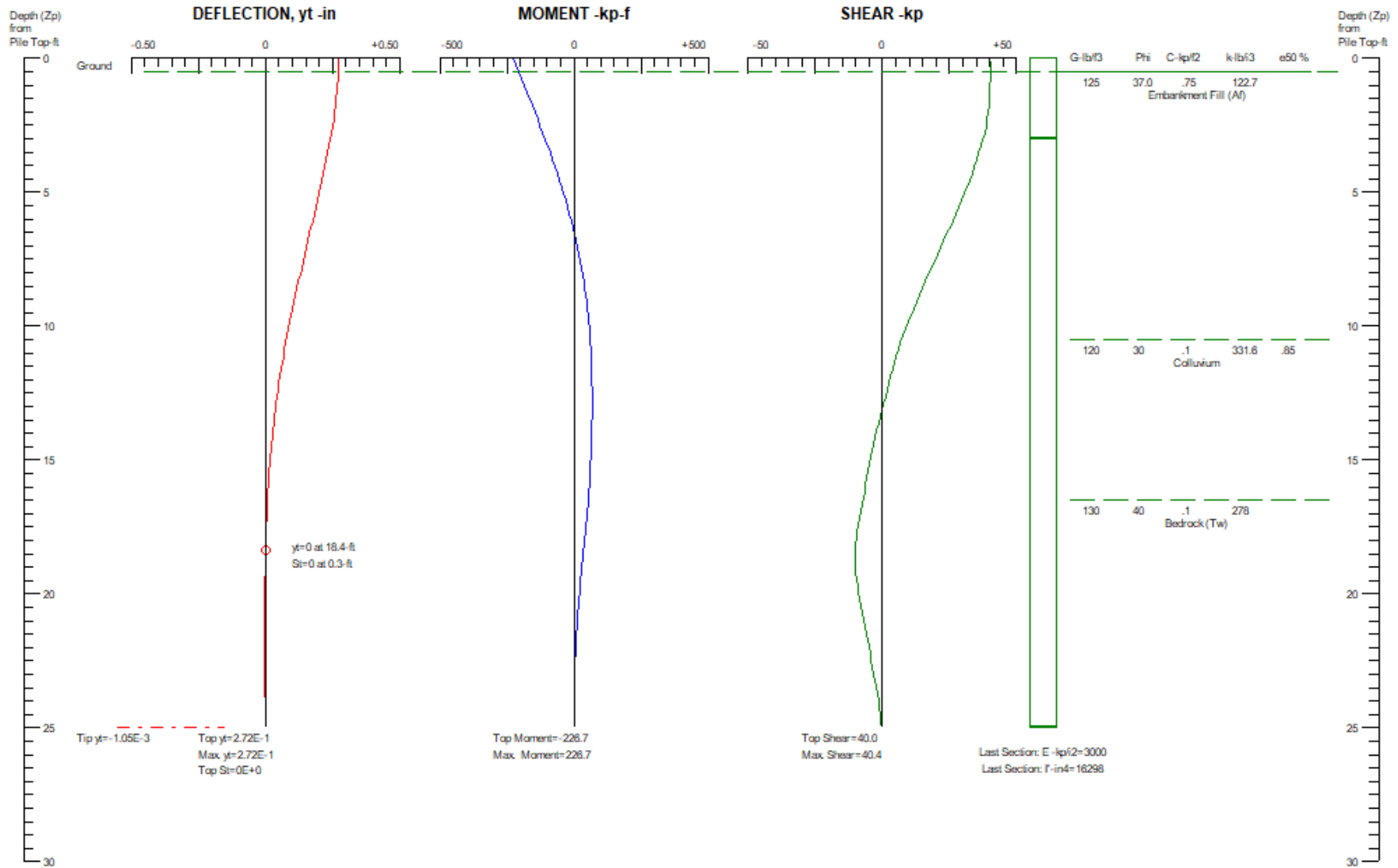

**CivilTech
Software**

**Lot 44
Foundations P9 & P10**

Figure 2

ØLoad_L

Depth vs. Deflection, Moment, Shear, and Slope in Single Pile:

Zp -ft	yt -in	Moment -kp-f	Shear -kp	Pressure -kp/f2	Slope
0.0	0.272	-226.7	40.0	0.0	0.00000
0.3	0.272	-216.7	40.3	0.0	0.00000
0.5	0.271	-206.7	40.4	0.0	-0.00033
0.8	0.270	-195.8	40.3	0.0	-0.00033
1.0	0.268	-185.8	40.1	-0.1	-0.00066
1.3	0.266	-175.8	39.9	-0.1	-0.00066
1.5	0.264	-165.8	39.8	-0.1	-0.00066
1.8	0.261	-155.8	39.7	-0.2	-0.00099
2.0	0.258	-145.8	39.4	-0.2	-0.00099
2.3	0.254	-135.8	39.1	-0.2	-0.00132
2.5	0.250	-125.8	38.7	-0.3	-0.00132
2.8	0.246	-116.7	38.2	-0.3	-0.00132
3.0	0.242	-106.7	37.5	-0.3	-0.00132
3.3	0.237	-97.5	36.7	-0.4	-0.00165
3.5	0.232	-88.3	35.9	-0.4	-0.00165
3.8	0.227	-79.7	35.1	-0.4	-0.00165
4.0	0.222	-70.9	34.3	-0.5	-0.00165
4.3	0.217	-62.4	33.4	-0.5	-0.00164
4.5	0.211	-54.2	32.5	-0.5	-0.00198
4.8	0.206	-46.2	31.6	-0.5	-0.00165
5.1	0.200	-38.4	30.6	-0.5	-0.00198
5.3	0.194	-30.9	29.5	-0.5	-0.00198
5.6	0.188	-23.8	28.5	-0.6	-0.00198
5.8	0.182	-16.8	27.3	-0.6	-0.00198
6.1	0.176	-10.2	26.2	-0.6	-0.00198
6.3	0.170	-3.9	25.1	-0.6	-0.00198
6.6	0.164	2.2	23.9	-0.6	-0.00198
6.8	0.158	7.9	22.8	-0.6	-0.00198
7.1	0.152	13.4	21.6	-0.6	-0.00198
7.3	0.146	18.6	20.5	-0.6	-0.00198
7.6	0.140	23.4	19.3	-0.6	-0.00198
7.8	0.134	28.1	18.2	-0.5	-0.00198
8.1	0.129	32.3	17.1	-0.5	-0.00165
8.3	0.123	36.4	16.0	-0.5	-0.00198
8.6	0.117	40.2	15.0	-0.5	-0.00198
8.8	0.112	43.7	13.9	-0.5	-0.00165
9.1	0.106	46.9	12.8	-0.5	-0.00198
9.3	0.101	49.9	11.8	-0.5	-0.00165
9.6	0.096	52.6	10.7	-0.5	-0.00178
9.8	0.090	55.0	9.6	-0.5	-0.00168
10.1	0.086	57.2	8.6	-0.5	-0.00165
10.4	0.081	59.1	7.7	-0.4	-0.00162
10.6	0.076	60.8	6.8	-0.4	-0.00155
10.9	0.071	62.2	6.0	-0.3	-0.00152
11.1	0.067	63.5	5.2	-0.3	-0.00149
11.4	0.063	64.7	4.5	-0.3	-0.00142
11.6	0.058	65.6	3.8	-0.3	-0.00139
11.9	0.054	66.3	3.1	-0.3	-0.00132
12.1	0.050	67.0	2.5	-0.3	-0.00129
12.4	0.047	67.4	1.8	-0.3	-0.00122
12.6	0.043	67.8	1.1	-0.3	-0.00118
12.9	0.040	67.8	0.5	-0.3	-0.00112
13.1	0.036	67.8	-0.2	-0.3	-0.00109
13.4	0.033	67.6	-0.8	-0.3	-0.00102
13.6	0.030	67.2	-1.4	-0.3	-0.00099
13.9	0.027	66.7	-2.0	-0.3	-0.00092
14.1	0.025	66.0	-2.6	-0.3	-0.00089
14.4	0.022	65.2	-3.2	-0.3	-0.00083

						θLoad_L
14.6	0.020	64.3	-3.8	-0.3		-0.00079
14.9	0.018	63.1	-4.3	-0.2		-0.00073
15.2	0.016	61.9	-4.8	-0.2		-0.00069
15.4	0.014	60.5	-5.3	-0.2		-0.00063
15.7	0.012	59.1	-5.8	-0.2		-0.00059
15.9	0.010	57.5	-6.2	-0.2		-0.00056
16.2	0.009	55.8	-6.7	-0.2		-0.00051
16.4	0.007	54.0	-7.1	-0.2		-0.00047
16.7	0.006	52.1	-7.6	-0.3		-0.00043
16.9	0.005	50.1	-8.2	-0.3		-0.00039
17.2	0.004	47.8	-8.6	-0.2		-0.00035
17.4	0.003	45.5	-9.1	-0.2		-0.00032
17.7	0.002	43.1	-9.5	-0.1		-0.00028
17.9	0.001	40.6	-9.8	-0.1		-0.00025
18.2	0.000	38.0	-10.0	0.0		-0.00022
18.4	0.000	35.4	-10.1	0.0		-0.00019
18.7	-0.001	32.8	-10.1	0.1		-0.00017
18.9	-0.001	30.3	-10.0	0.1		-0.00014
19.2	-0.001	27.7	-9.9	0.1		-0.00012
19.4	-0.002	25.3	-9.6	0.2		-0.00010
19.7	-0.002	22.8	-9.3	0.2		-0.00008
19.9	-0.002	20.6	-8.9	0.2		-0.00006
20.2	-0.002	18.4	-8.5	0.2		-0.00005
20.5	-0.002	16.3	-8.1	0.2		-0.00003
20.7	-0.002	14.4	-7.6	0.2		-0.00002
21.0	-0.002	12.6	-7.2	0.3		-0.00001
21.2	-0.002	10.9	-6.7	0.3		0.00000
21.5	-0.002	9.3	-6.2	0.3		0.00001
21.7	-0.002	7.9	-5.6	0.3		0.00001
22.0	-0.002	6.6	-5.1	0.3		0.00002
22.2	-0.002	5.4	-4.6	0.2		0.00002
22.5	-0.002	4.4	-4.1	0.2		0.00003
22.7	-0.002	3.5	-3.7	0.2		0.00003
23.0	-0.002	2.7	-3.2	0.2		0.00003
23.2	-0.002	2.0	-2.7	0.2		0.00004
23.5	-0.002	1.5	-2.3	0.2		0.00004
23.7	-0.002	1.0	-1.9	0.2		0.00004
24.0	-0.002	0.6	-1.5	0.2		0.00004
24.2	-0.001	0.3	-1.1	0.2		0.00004
24.5	-0.001	0.1	-0.8	0.2		0.00004
24.7	-0.001	0.0	-0.5	0.1		0.00004
25.0	-0.001	0.0	0.0	0.1		0.00004

Zp - Depth from pile Top
 yt - Pile top deflection
 Moment - Internal moment in pile shaft
 Shear - Internal shear force in pile shaft
 Pressure - Soil-Pile interactive pressure (Arching is considered)
 Slope - Deflection slope at pile top

Lateral Load vs Deflection and Max. Moment

P	Q	yt	St	Mmax
-kp	-kp	-in		-kp-f
4.0	460.0	0.01	0.000	-17.3
12.0	460.0	0.04	0.000	-51.9
20.0	460.0	0.09	0.000	-96.7
28.0	460.0	0.15	0.000	-145.8
32.0	460.0	0.19	0.000	-172.5
36.0	460.0	0.23	0.000	-199.2
40.0	460.0	0.27	0.000	-226.7

P - Lateral load at pile top
 Q - Vertical load at pile top
 yt - Lateral deflection at pile top
 St - Deflection slope at pile top
 Mmax - Max. moment in a single pile

PILE DEFLECTION vs LOADING Single Pile, Khead=5, Kbc=2

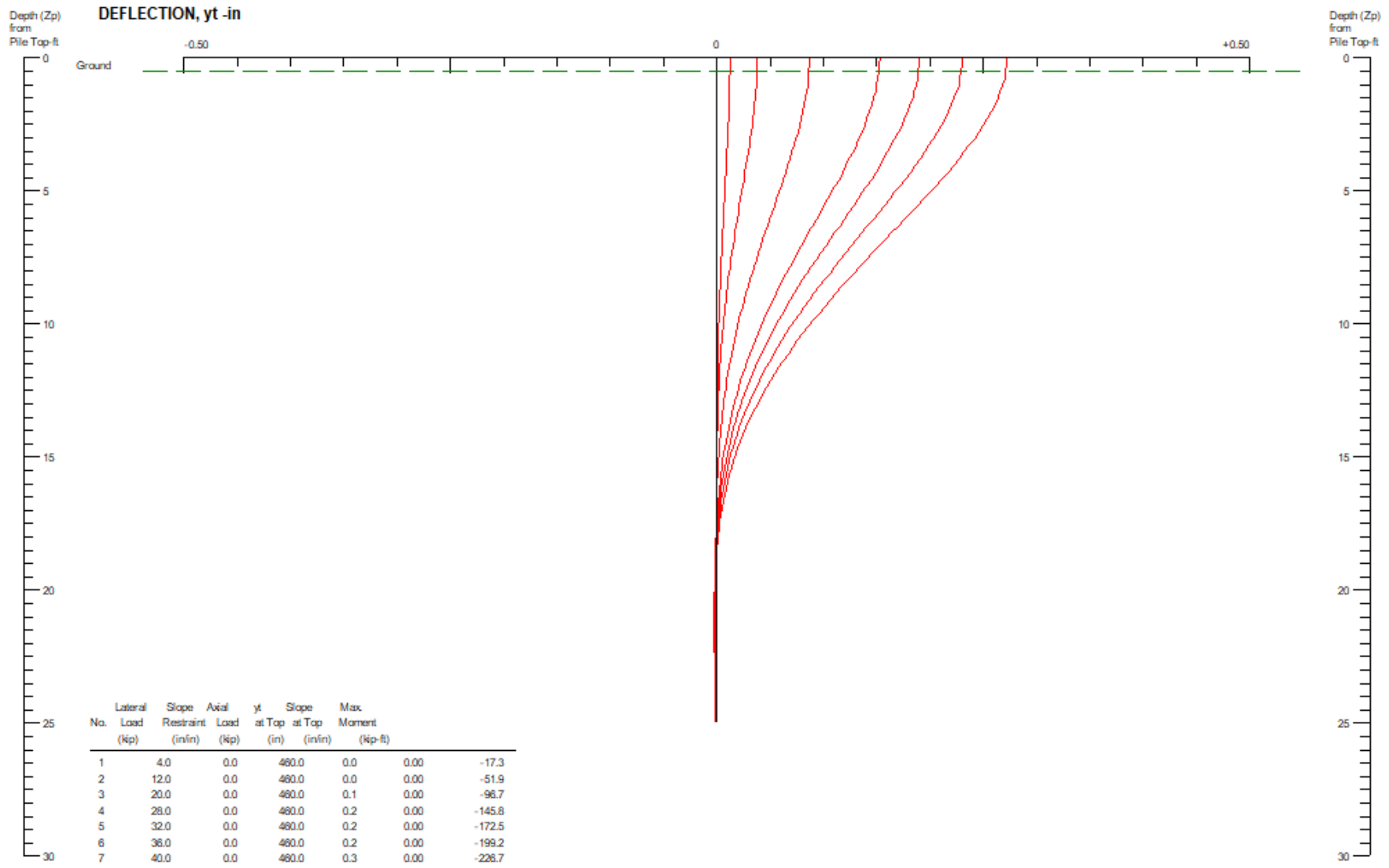

**CivilTech
Software**

**Lot 44
Foundations P9 & P10**

Figure 2

PILE MOMENT vs LOADING Single Pile, Khead=5, Kbc=2

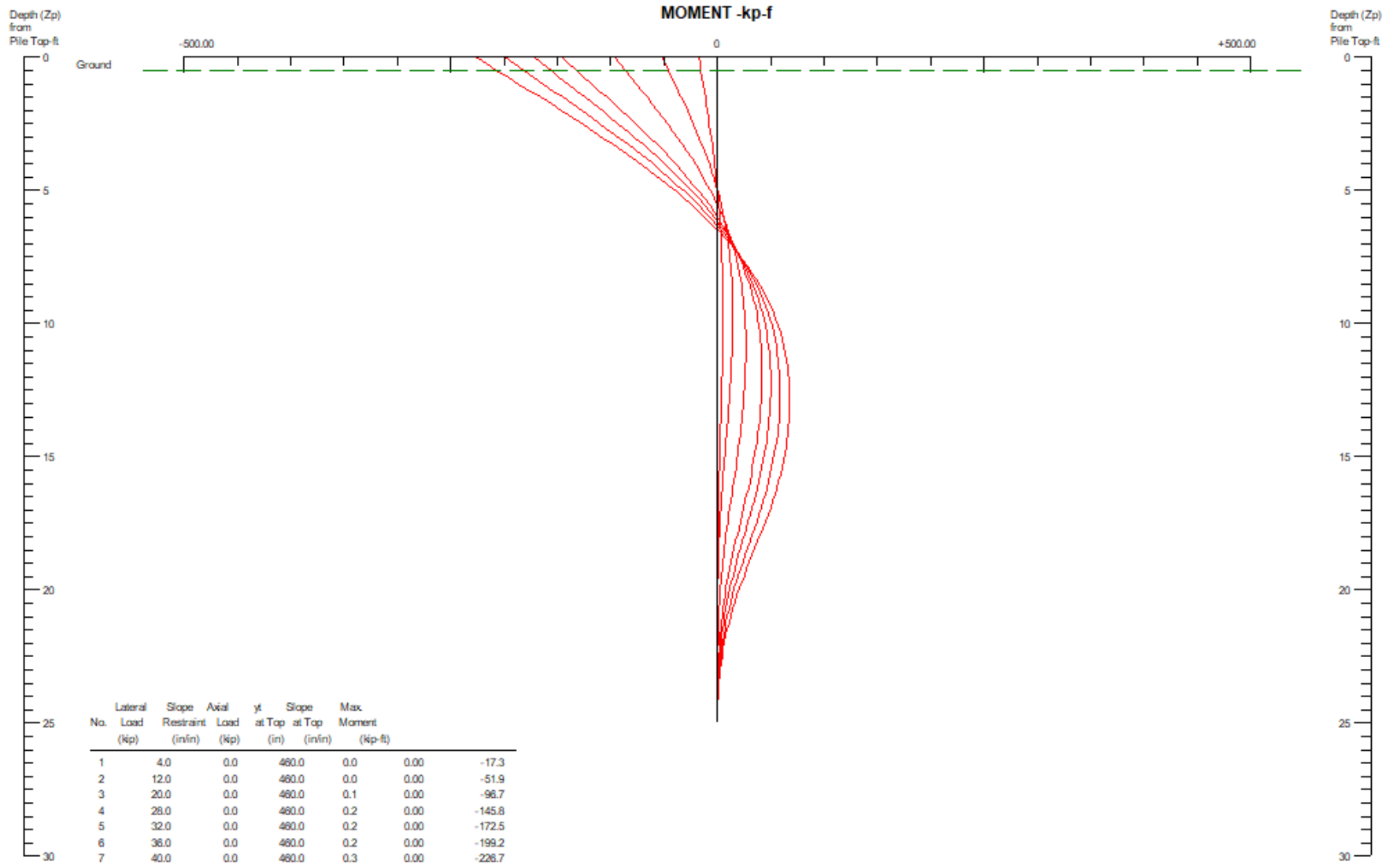

**CivilTech
Software**

**Lot 44
Foundations P9 & P10**

Figure 2

LATERAL LOAD vs DEFLECTION & MAX. MOMENT

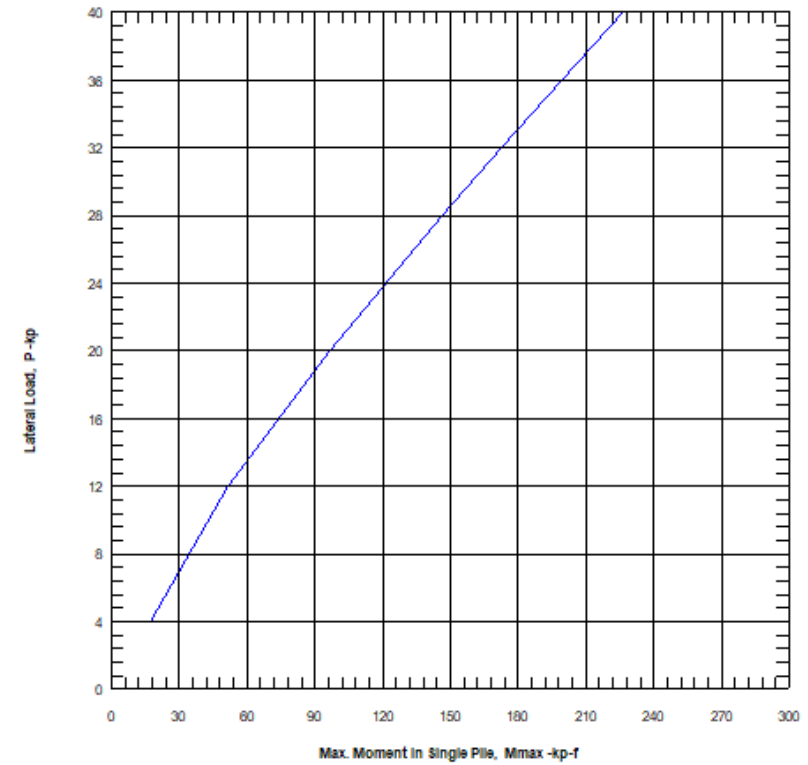
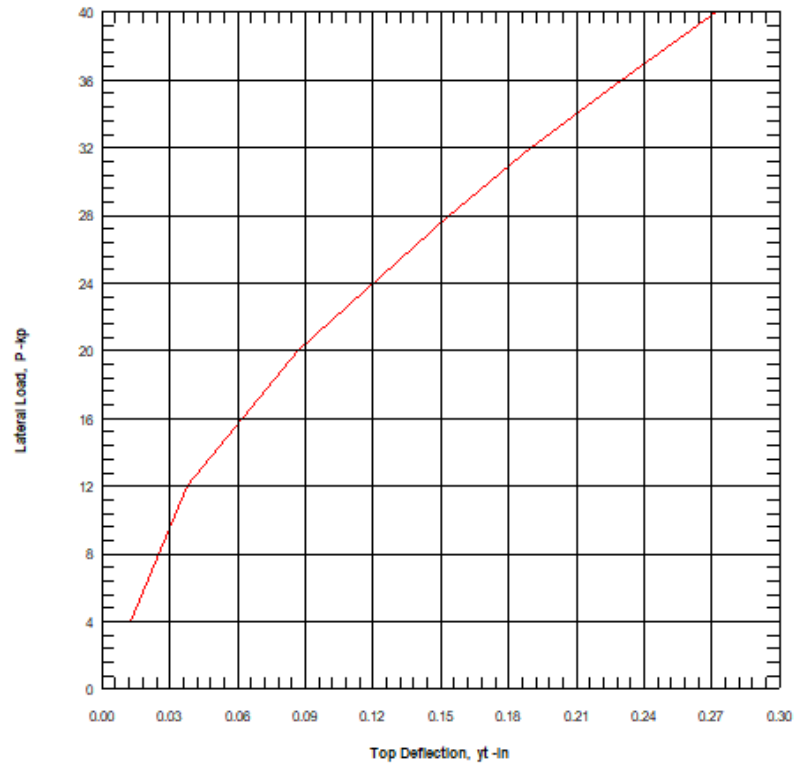

Soil Resistance vs. Pile Deflection (p-y)

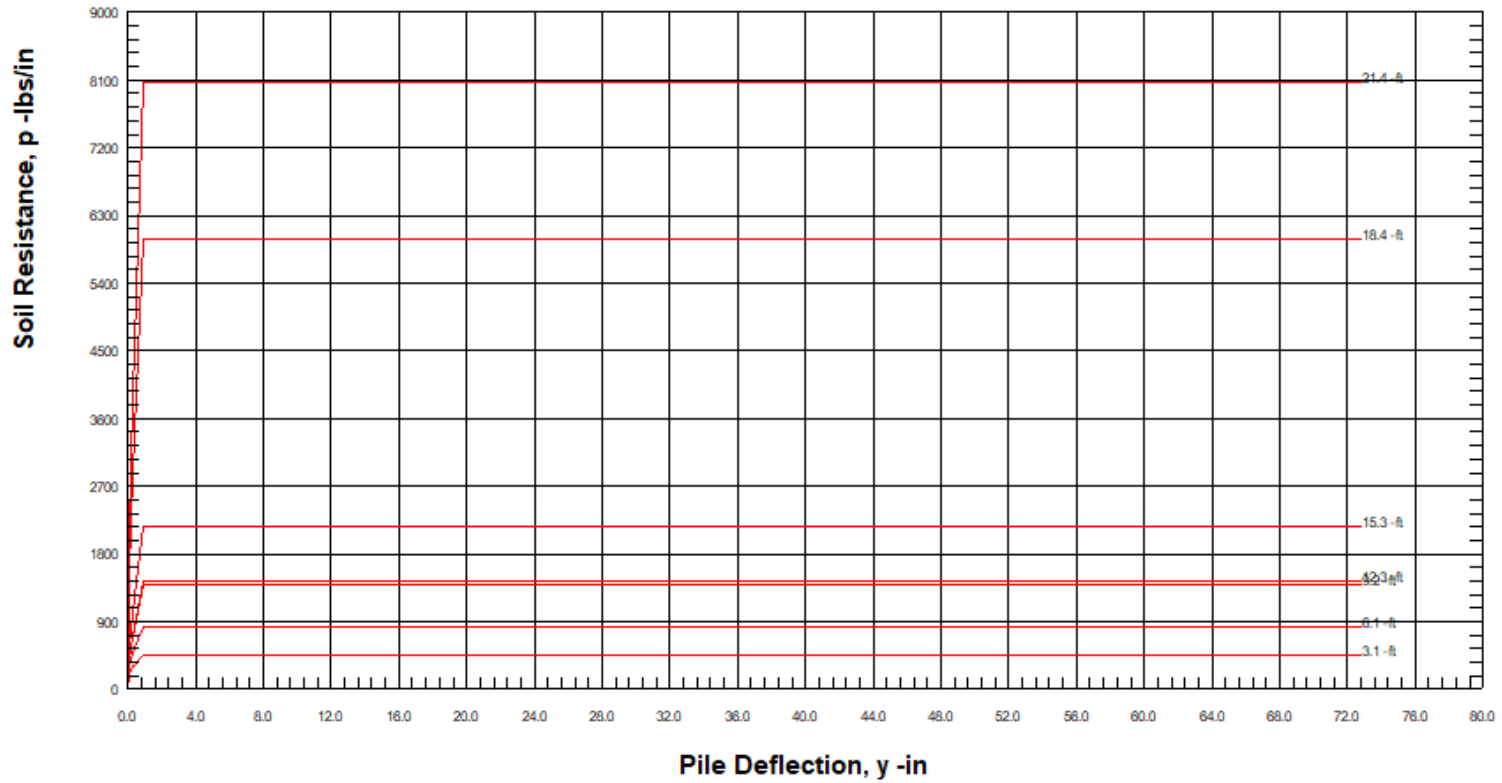

Soil Depth (Zs): 3.1, 6.1, 9.2, 12.3, 15.3, 18.4, 21.4 -ft



Soil Resistance vs. Pile Deflection (p-y)

Zs -ft	p -lbs/in	y -in
3.06	0.0	0.000
3.06	148.8	0.033
3.06	184.4	0.067
3.06	209.0	0.100
3.06	228.5	0.133
3.06	244.9	0.167
3.06	259.1	0.200
3.06	271.8	0.233
3.06	283.2	0.267
3.06	293.8	0.300
3.06	303.5	0.333
3.06	312.6	0.367
3.06	321.1	0.400
3.06	445.5	0.900
3.06	445.5	24.900
3.06	445.5	48.900
3.06	445.5	72.900
6.13	0.0	0.000
6.13	201.1	0.033
6.13	265.7	0.067
6.13	312.8	0.100
6.13	351.2	0.133
6.13	384.1	0.167
6.13	413.4	0.200
6.13	439.8	0.233
6.13	464.0	0.267
6.13	486.6	0.300
6.13	507.6	0.333
6.13	527.5	0.367
6.13	546.2	0.400
6.13	820.8	0.900
6.13	820.8	24.900
6.13	820.8	48.900
6.13	820.8	72.900
9.19	0.0	0.000
9.19	188.1	0.033
9.19	282.6	0.067
9.19	358.6	0.100
9.19	424.6	0.133
9.19	484.1	0.167
9.19	538.8	0.200
9.19	589.8	0.233
9.19	637.9	0.267
9.19	683.6	0.300
9.19	727.3	0.333
9.19	769.1	0.367
9.19	809.5	0.400
9.19	1403.7	0.900
9.19	1403.7	24.900
9.19	1403.7	48.900
9.19	1403.7	72.900
12.25	0.0	0.000
12.25	181.8	0.033
12.25	277.0	0.067

ØLoad_L

12.25	354.5	0.100
12.25	422.3	0.133
12.25	483.6	0.167
12.25	540.3	0.200
12.25	593.4	0.233
12.25	643.6	0.267
12.25	691.4	0.300
12.25	737.1	0.333
12.25	781.1	0.367
12.25	823.5	0.400
12.25	1449.4	0.900
12.25	1449.4	24.900
12.25	1449.4	48.900
12.25	1449.4	72.900
15.31	0.0	0.000
15.31	270.5	0.033
15.31	412.2	0.067
15.31	527.5	0.100
15.31	628.3	0.133
15.31	719.6	0.167
15.31	804.0	0.200
15.31	883.0	0.233
15.31	957.6	0.267
15.31	1028.7	0.300
15.31	1096.8	0.333
15.31	1162.2	0.367
15.31	1225.4	0.400
15.31	2156.6	0.900
15.31	2156.6	24.900
15.31	2156.6	48.900
15.31	2156.6	72.900
18.38	0.0	0.000
18.38	750.1	0.033
18.38	1143.3	0.067
18.38	1463.0	0.100
18.38	1742.6	0.133
18.38	1995.8	0.167
18.38	2229.8	0.200
18.38	2448.9	0.233
18.38	2656.0	0.267
18.38	2853.2	0.300
18.38	3041.9	0.333
18.38	3223.4	0.367
18.38	3398.5	0.400
18.38	5981.4	0.900
18.38	5981.4	24.900
18.38	5981.4	48.900
18.38	5981.4	72.900
21.44	0.0	0.000
21.44	1010.9	0.033
21.44	1540.8	0.067
21.44	1971.6	0.100
21.44	2348.4	0.133
21.44	2689.7	0.167
21.44	3005.0	0.200
21.44	3300.2	0.233
21.44	3579.3	0.267
21.44	3845.0	0.300
21.44	4099.4	0.333
21.44	4344.0	0.367
21.44	4580.0	0.400
21.44	8060.8	0.900
21.44	8060.8	24.900
21.44	8060.8	48.900

21.44	8060.8	72.900	0Load_L
-------	--------	--------	---------

Zs - Depth from Soil Top
p - Soil Resistance
y - Pile Deflection