



## Land Use Permit

### Weber County Planning Commission

2380 Washington Blvd. STE 240

Ogden, UT 84401

Phone: (801) 399-8791 FAX: (801) 399-8862

webercountyutah.gov/planning

**Permit Number: LUP154-2018**

Permit Type: Structure

Permit Date: 06/25/2018

### Applicant

**Name:** Signature Builders  
**Business:**  
**Address:** 3625 S Honeycutt Rd  
SLC, UT 84106  
**Phone:** 801-699-4571

### Owner

**Name:** SMHG Village Development LLC  
**Business:**  
**Address:** 3923 N Wolf Creek Dr  
Eden, UT 84310  
**Phone:** 435-640-7002

### Parcel

**Parcel:** 231510028

**Zoning:** DRR-1 **Area:** .0264 **Sq Ft:** **Lot(s):** 129 **Subdivision:** Horizon PRUD Amd 1  
**Address:** 7866 E HORIZON RUN RD EDEN, UT 84310 **T - R - S - QS:** 7N - 2E - 6 - SE

### Proposal

**Proposed Structure:** Single Family Dwelling

**Proposed Structure Height:** 34

**# of Dwelling Units:** 1

**# Off Street Parking Reqd:** 1

**Building Footprint:** 666

**Max Structure Height in Zone:** 35

**# of Accessory Bldgs:**

**\*Is Structure > 1,000 Sq. Ft?** N/A

\*If True Need Certif. Statement

### Permit Checklist

**Access Type:** Across front lot line

**Greater than 4218 ft above sea level?** Yes

**Additional Setback Reqd. ?** No

**> 200 ft from paved Road?** N/A

**Culinary Water District:** PMSWID

**Alternative Access File #**

**Wetlands/Flood Zone?** No

**Meet Zone Area Frontage?** Yes

**Hillside Review Reqd?** N/A

**Waste Water System:** PMWSID

### Comments

All site improvements including the location of the single family residence and the final grading/landscaping of the site shall strictly adhere to the recommendations outlined in the Geologic Hazards Assessment Report from IGES Project# 01628-013 dated August 3, 2016 (revised July 19, 2017). It is recommended that IGES is present during the excavation of the home site to evaluate the site specific soil conditions which will allow IGES to make any necessary modifications to the recommendations outlined in the report if differing conditions are encountered during excavation. Prior to receiving the final occupancy, a Natural Hazards Notice (to be provided by Weber County) must be recorded with the Weber County Recorder's office per LUC #104-27-5. All outdoor lighting must be in compliance with Ogden Valley Outdoor lighting standards.

# Land Use Permit

## Structure Setback Graphic: New Dwelling, Addition, Etc.

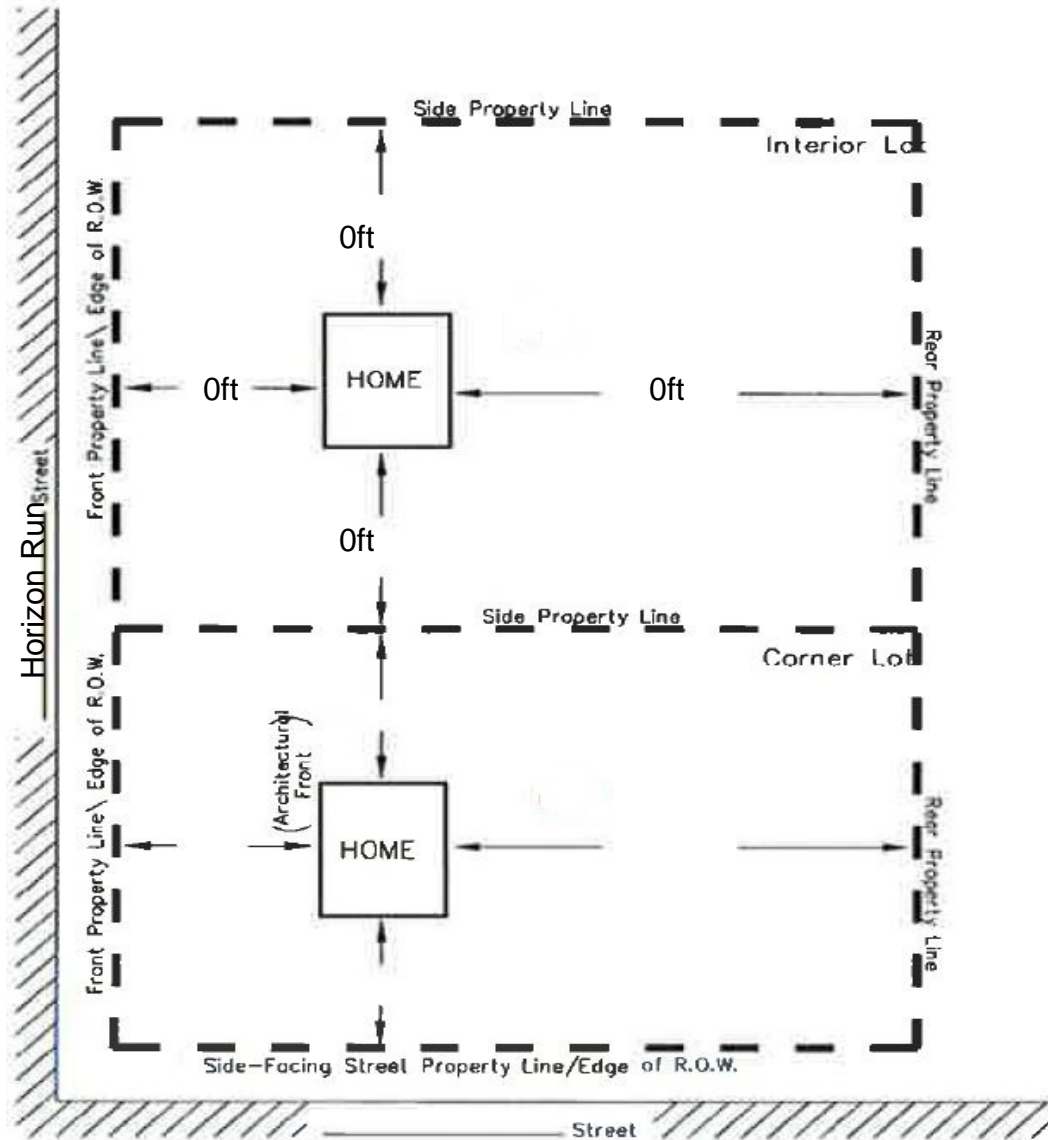

### MINIMUM YARD SETBACKS New Dwelling, Addition, Etc.

#### NOTICE FOR APPLICANT (Please Read Before Signing)

Proposals for the installation of an individual water supply and for a sanitary waste disposal system (septic tank) for any structure designed for human occupation must be approved by Weber County Health Department prior to installation.

**Steven Burton**

**06/25/2018**

\_\_\_\_\_  
Planning Dept. Signature of Approval

\_\_\_\_\_  
Date

I hereby certify that I have read and examined this application and know the same to be true and correct. All provisions of laws and ordinances governing this land use will be complied with whether specified herein or not. I make this statement under penalty of perjury.

\_\_\_\_\_  
Contractor/Owner Signature of Approval

\_\_\_\_\_  
Date