

The Chalets at Ski Lake Phase 7

A Cluster Subdivision

a part of the of Northeast 1/4 of Section 23, T6N, R1E, SLB&M, U.S. Survey
Weber County, Utah
April 2012

North 1/4 corner of Section 23, T6N, R1E, SLB&M, U.S. Survey, Found Bureau of Land Management, Brass Cap, Good Condition, 0.4' above natural ground dated 1967
N 89°38'44" W W.C.S. (N 89°38'27" W)

SURVEYOR'S CERTIFICATE
I, Mark E. Babbitt, do hereby certify that I am a Registered Professional Land Surveyor in the State of Utah, and that I hold Certificate No. 166484 in accordance with Title 58 Chapter 22, Professional Engineers and Land Surveyors Licensing Act. I also do hereby certify that The Chalets at Ski Lake Phase 7, A Cluster Subdivision in Weber County, Utah has been correctly drawn to the designated scale and is a true and correct representation of the following description of lands included in said subdivision, based on data compiled from records in the Weber County Recorder's Office, and of a survey made on the ground in accordance with Section 17-23-17. Monumented Lot corners have been set as shown on this drawing. I also certify that all the lots within The Chalets at Ski Lake Phase 5, A Cluster Subdivision meet the frontage and area requirements of the Weber County Zoning Ordinance.
Signed this _____ day of _____, 2012.

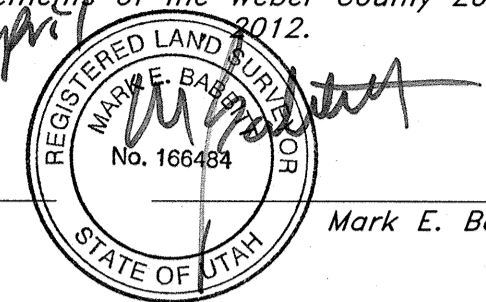

166484
License No.

OWNER'S DEDICATION

I, the undersigned owner of the herein described tract of land, do hereby set apart and subdivide the same into lots and streets as shown on the plat and name this tract The Chalets at Ski Lake Phase 7, a Cluster Subdivision and do hereby dedicate to public use all those parts or portions of said tract of land designated as streets, the same to be used as public thoroughfares, also grant and convey to the subdivision lot (unit) Owners Association, all those parts or portions of said tract of land designated as Common Areas to be used for recreational and open space purposes for the benefit of each lot (unit) Owners Association member in common with all others in the subdivision and grant and dedicate to Weber County a perpetual Open Space Right and Easement on and over the Common Areas to guarantee to Weber County that the Common Areas remain open and undeveloped except for approved recreational, parking and open space purposes, and also grant and dedicate a perpetual right and easement over, upon and under the lands designated hereof as public utility, storm water detention ponds drainage easements and canal maintenance easement, the same to be used for the installation, maintenance and operation of public utility service lines, storm drainage facilities, irrigation canals or for the perpetual preservation of water channels in their natural state whichever is applicable as may be authorized by governing authority with no buildings or structures being erected within such easements.
Dedicate, grant and convey to Weber County, Utah, or its designee, all those parts or portions of said tract of land designated as parks the same to be used as public open space.
Signed this _____ day of _____, 2012.

Valley Enterprise Investment Company, LLC.

Ray Bowden - President

State of }
County of }
On the _____ day of _____, 2012, personally appeared before me, Ray Bowden who being by me duly sworn did say that he is President of Valley Enterprise Investment Company, LLC. and that said instrument was signed in behalf of said Corporation by a resolution of its Board of Directors and Ray Bowden acknowledged to me that said Corporation executed the same.

Residing at: _____ A Notary Public commissioned in Utah

Commission Expires: _____ Print Name _____

BOUNDARY DESCRIPTION

A part of the Northeast Quarter of Section 23, Township 6 North, Range 1 East, Salt Lake Base and Meridian, U.S. Survey:
Beginning at the Northeast corner of Lot 42 of The Chalets at Ski Lake Phase 6 a Cluster Subdivision in Weber County, which point is 543.52 feet North 89°38'27" West along the Section line, and 639.03 feet South 0°21'33" West from the Northeast Corner of said Section 23; and running thence along the Southerly boundary lines of The Chalets at Ski Lake Phase 4 and Phase 2 the following seven (7) courses:
South 64°35'30" East 558.70 feet, South 44°24'47" East 299.29 feet, South 26°08'20" East 221.18 feet, North 67°07'56" East 141.41 feet, Southwesterly along the arc of a 234.00 foot radius curve to the right a distance of 132.30 feet (Central Angle is 32°23'35" and Long Chord bears South 41°30'49" West 130.54 feet), Southwesterly along the arc of a 441.00 foot radius curve to the left a distance of 38.01 feet (Central Angle is 4°56'18" and Long Chord bears South 55°14'27" West 38.00 feet), South 61°02'58" East 217.90 feet to the Westerly right of way line of Snow Basin Road; thence following said right of way line Southwesterly along the arc of a 205.28 foot radius curve to the right a distance of 134.61 feet (Central Angle is 37°34'17" and Long Chord bears South 10°08'12" West 132.22 feet) to the North line of Samarel Family Invest Co. LLC parcel; thence following said Samarel parcel the following four (4) courses: South 89°45'15" West 9.99 feet, Southwesterly along the arc of a 767.46 foot radius curve to the left a distance of 331.58 feet (Central Angle is 24°45'15" and Long Chord bears South 77°22'38" West 329.01 feet), South 65°00'00" West 50.00 feet, Southwesterly along the arc of a 664.32 foot radius curve to the right a distance of 219.94 feet (Central Angle is 19°03'24" and Long Chord bears South 74°31'42" West 174.84 feet), West 201.52 feet to the West line of said Samarel parcel; thence along said West parcel line South 0°48'23" West 201.52 feet to the North line of Nord Investment Co. parcel; thence following said Nord parcel North 89°11'37" West 476.43 feet; thence North 0°48'23" East 25.00 feet; thence South 89°11'37" East 451.43 feet; thence North 0°48'23" East 221.51 feet; thence North 23°10'38" West 60.00 feet; thence Northwesterly along the arc of a 465.00 foot radius curve to the left a distance of 101.98 feet (Central Angle is 12°33'57" and Long Chord bears North 60°32'23" East 101.78 feet); thence North 35°44'35" West 174.84 feet; thence South 79°36'04" West 135.95 feet; thence North 88°37'56" West 130.00 feet; thence South 20°07'51" West 156.83 feet; thence North 40°15'49" West 184.82 feet; thence North 47°49'40" East 140.00 feet; thence North 77°30'13" East 194.13 feet; thence North 40°35'38" East 276.07 feet; thence North 5°09'15" West 111.88 feet; thence North 74°05'42" West 181.13 feet to the Easterly boundary line of said Chalets at Ski Lake Phase 6; thence following said Easterly boundary line the following five (5) courses: North 27°15'33" East 225.07 feet, Southeastly along the arc of a 405.00 foot radius curve to the left a distance of 47.80 feet (Central Angle is 6°45'47" and Long Chord bears South 59°21'34" East 47.78 feet, South 55°58'40" East 30.75 feet, North 34°01'19" East 60.00 feet, and North 25°24'30" East 137.44 feet to the point of beginning.

LEGEND

● Set 5/8" Rebar 24" long with plastic cap (see detail above) was set at all property corners as shown.
○ Set 5/8" Rebar 24" long & Cap w/Fencepost
◆ Monument (to be set)
◆ Found Section corner

Scale: 1" = 100'
Graphic Scale

BOUNDARY CURVE DATA

(A)	(B)	(C)	(D)
Δ = 32°23'35"	Δ = 4°56'18"	Δ = 37°34'17"	Δ = 24°45'15"
R = 234.00'	R = 441.00'	R = 205.28'	R = 767.46'
L = 132.30'	L = 38.01'	L = 134.61'	L = 331.58'
LC = 130.54'	LC = 38.00'	LC = 132.22'	LC = 329.00'
S 41°30'49" W	S 55°14'27" W	S 10°08'12" W	S 77°22'38" W

PROPERTY LINE CURVE DATA

(1)	(2)	(3)	(4)
Δ = 20°36'37"	Δ = 9°53'01"	Δ = 33°09'11"	Δ = 27°53'25"
R = 360.00'	R = 205.00'	R = 205.00'	R = 205.00'
L = 129.50'	L = 35.36'	L = 118.52'	L = 99.79'
LC = 128.80'	LC = 35.32'	LC = 116.99'	LC = 98.81'
N 8°36'11" E	N 71°38'48" W	N 50°07'42" W	N 19°36'24" W

CENTERLINE CURVE DATA

(C1)	(C2)	(C3)	(C4)
Δ = 20°36'37"	Δ = 134°17'54"	Δ = 12°16'24"	Δ = 70°27'28"
R = 360.00'	R = 175.00'	R = 300.00'	R = 495.00'
L = 140.29'	L = 410.19'	L = 107.10'	L = 61.55'
LC = 139.54'	LC = 322.53'	LC = 106.90'	LC = 61.51'
N 8°36'11" E	N 92°52'11" W	S 51°34'25" W	N 48°59'59" E

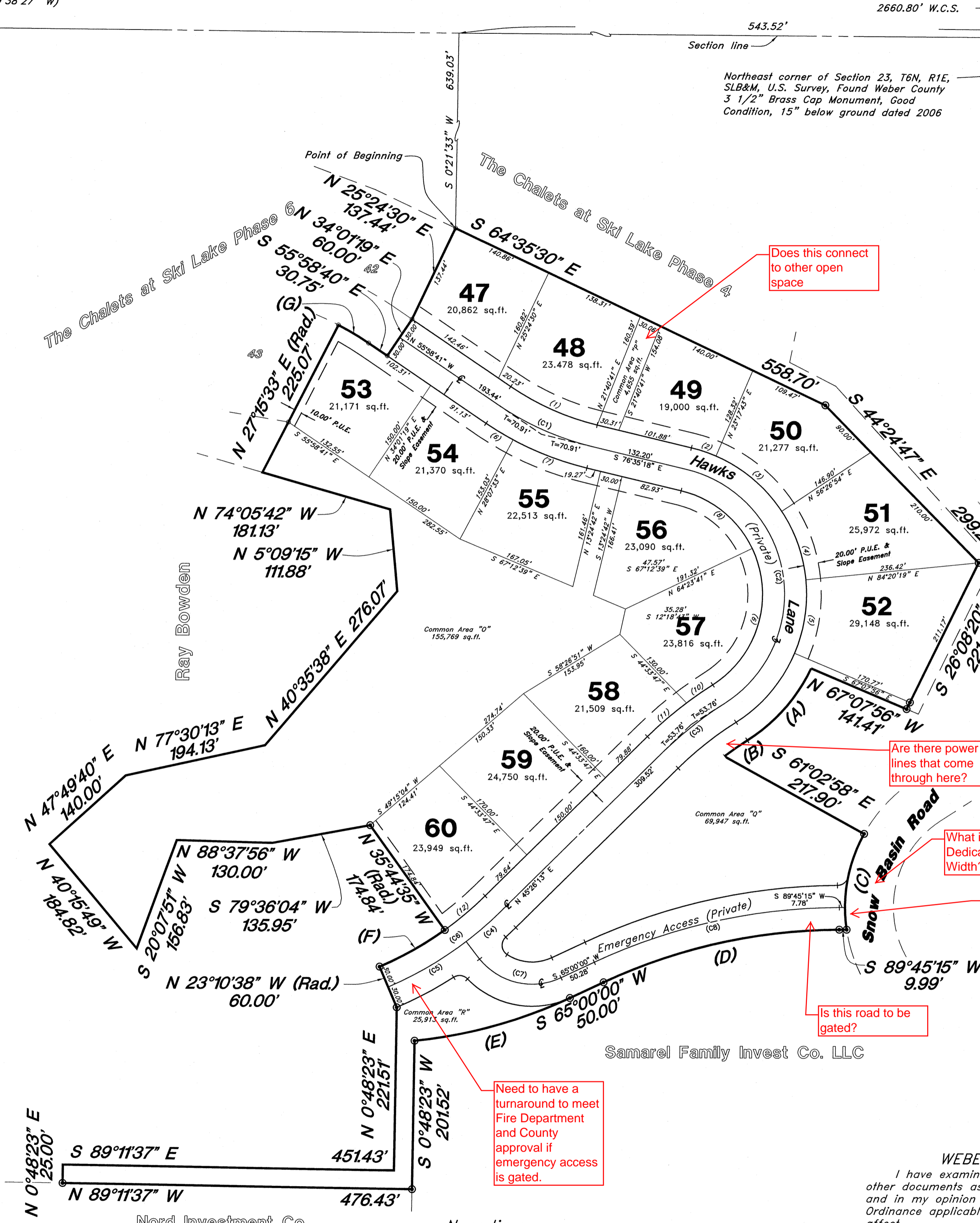

Narrative:

At the request of Ray Bowden, owner and developer, we have prepared this subdivision plat.
The basis of bearing for this plat is S 89°36'57" E between the Brass Caps found at the Northwest corner and the North 1/4 corner of Section 24, Township 6 North, Range 1 East, Salt Lake Base & Meridian, U.S. Survey.

NOTE:

- 10.00' wide Utility and Drainage Easements each side of Property line as indicated by dashed lines, except as otherwise shown.
- 20.00' cut and fill easements along front of lots as shown.
- Centerline monuments to be set upon completion of improvements, as shown.
- Common areas may be used as Public Utility Easements.

WEBER COUNTY ATTORNEY

I have examined the financial guarantee and other documents associated with this subdivision plat and in my opinion they conform with the County Ordinance applicable thereto and now in force and effect.
Signed this _____ day of _____, 2012.
Signature _____

OGDEN VALLEY TOWNSHIP PLANNING COMMISSION

This is to certify that this subdivision plat was duly approved by the Ogden Valley Township Planning Commission on the _____ day of _____, 2012.
Chair, Ogden Valley Township Planning Commission

WEBER COUNTY ENGINEER

I hereby certify that the required public improvement standards and drawings for this subdivision conform with County standards and the amount of the financial guarantee is sufficient for the installation of these improvements.
Signed this _____ day of _____, 2012.
Signature _____

WEBER COUNTY COMMISSION ACCEPTANCE

This is to certify that this subdivision plat, the dedication of streets and other public ways and financial guarantee of public improvements associated with this subdivision, thereon are hereby approved and accepted by the Commissioners of Weber County, Utah this _____ day of _____, 2012.
Title _____
Chair, Weber County Commission

WEBER COUNTY SURVEYOR

I hereby certify that the Weber County Surveyor's Office has reviewed this plat for mathematical correctness, section corner data, and for harmony with the lines and monuments on record in the County offices. The approval of this plat by the Weber County Surveyor does not relieve the Licensed Land Surveyor who executed this plat from the responsibilities and/or liabilities associated therewith.
Signed this _____ day of _____, 2012.
Signature _____

WEBER COUNTY RECORDER

ENTRY NO. _____ FEE PAID _____
RECORDED _____ FILED FOR RECORD AND AT _____
IN BOOK _____ OF OFFICIAL RECORDS, PAGE _____, RECORDED FOR _____
WEBER COUNTY RECORDER
BY: _____ DEPUTY

GREAT BASIN ENGINEERING NORTH
CONSULTING ENGINEERS AND SURVEYORS
5746 South 1475 East - Suite 200
Ogden, Utah 84403
P.O. Box 150048, Ogden, Utah 84415
Ogden (801)394-4315 Salt Lake City (801)521-0222 Fax (801)352-7544

Developer:
Valley Enterprise Investment Company, LLC.
Ray Bowden - President
5393 East 6850 North
Eden, UT. 84310

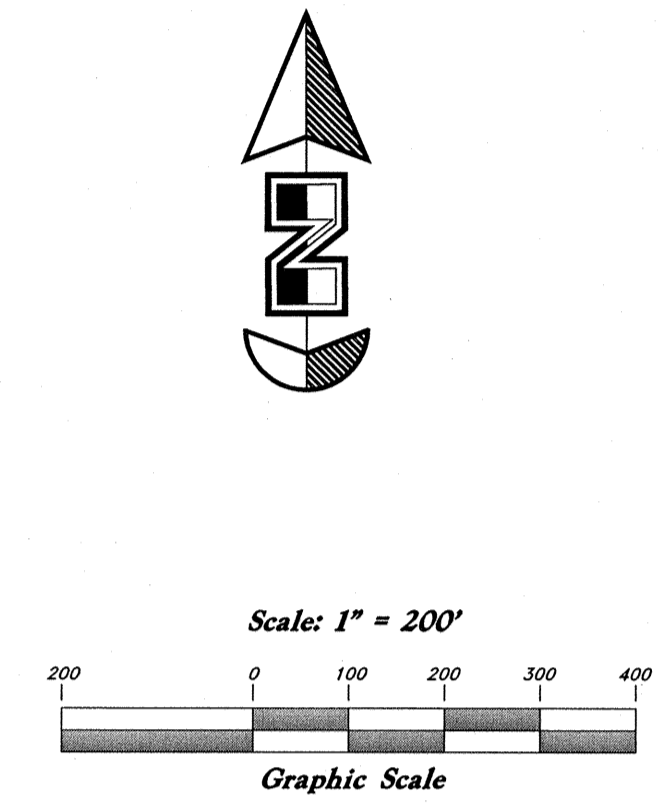
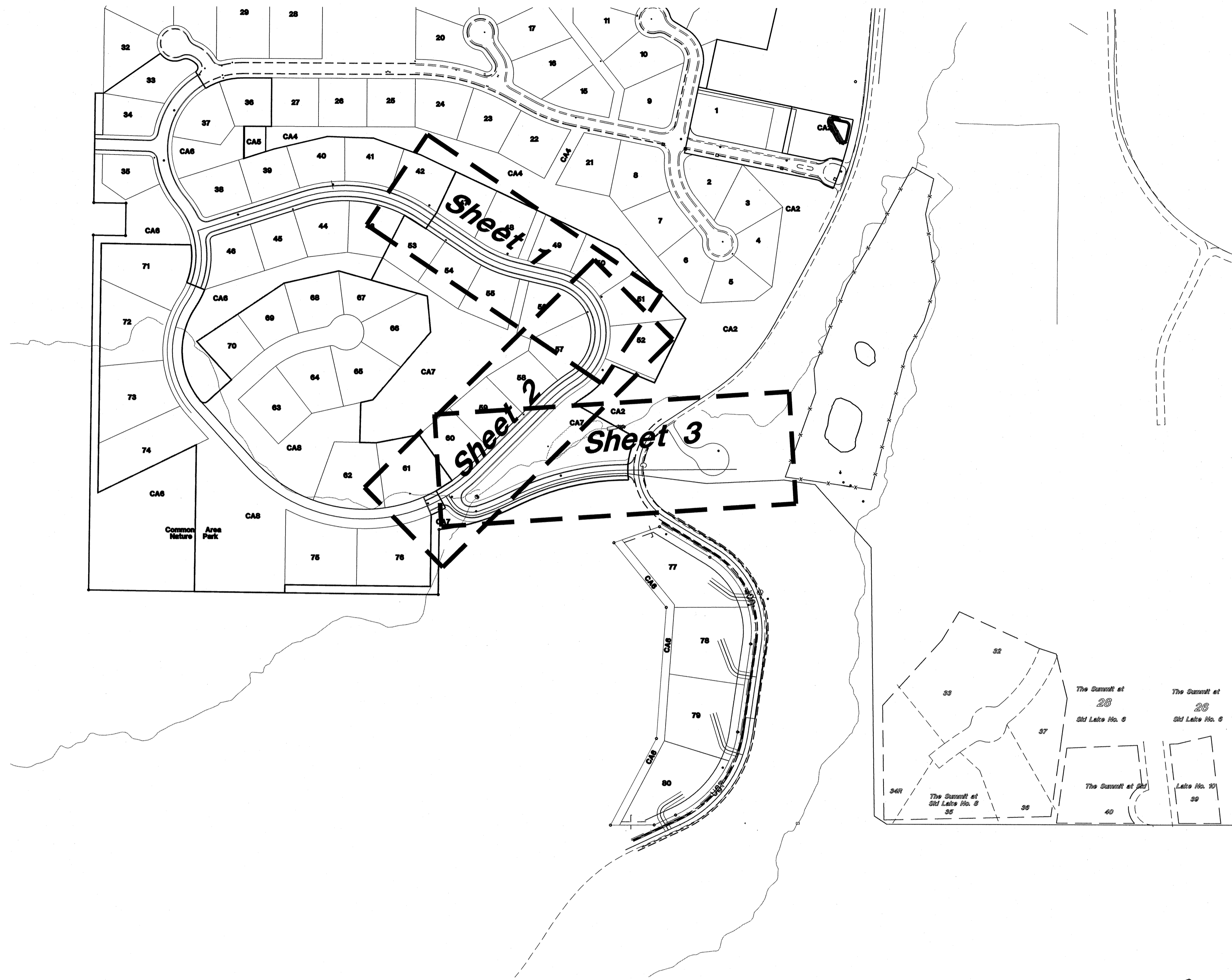

Legend

- (Note: All items may not appear on drawing)
- San. Sewer Manhole
 - Water Manhole
 - Storm Drain Manhole
 - Electrical Manhole
 - Catch Basins
 - Exist. Fire Hydrant
 - Fire Hydrant
 - Exist. Water Valve
 - Water Valve
 - Sanitary Sewer
 - Culinary Water
 - Gas Line
 - Irrigation Line
 - Storm Drain
 - Telephone Line
 - Secondary Waterline
 - Power Line
 - Fire Line
 - Land Drain
 - Power pole
 - Power pole w/guy
 - Light Pole
 - Fence
 - Flowline of ditch
 - Overhead Power line
 - Corrugated Metal Pipe
 - Concrete Pipe
 - Reinforced Concrete Pipe
 - Ductile Iron
 - Polyvinyl Chloride
 - Top of Asphalt
 - Edge of Asphalt
 - Centerline
 - Flowline
 - Finish Floor
 - Top of Curb
 - Top of Wall
 - Top of Walk
 - Top of Concrete
 - Natural Ground
 - Finish Contour
 - Exist. Contour
 - Finish Grade
 - Exist. Grade
 - Ridge Line
 - Direction of Flow
 - Existing Asphalt
 - New Asphalt
 - Heavy Duty Asphalt
 - Concrete
 - Open Face
 - Curb & Gutter

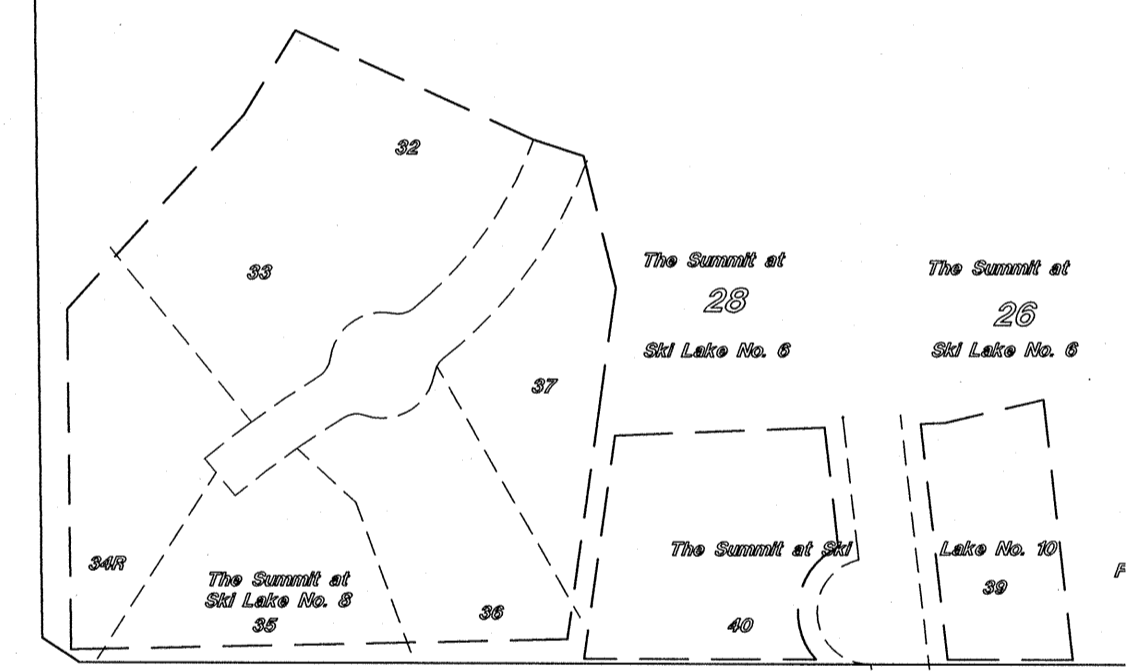

REV	DATE	DESCRIPTION

GREAT BASIN ENGINEERING

5746 SOUTH 1475 EAST OGDEN, UTAH 84403
 W.A. (801) 521-0222 FAX (801) 592-7544
 WWW.GREATBASINENGINEERING.COM

Key Map

The Chalets at Ski Lake No. 7

A part of the Southwest 1/4 of Section 13, a part of the Northeast 1/4 of Section 23, and a part of the Northwest 1/4 of Section 24, T6N, R1E, S188M, U.S. Survey.

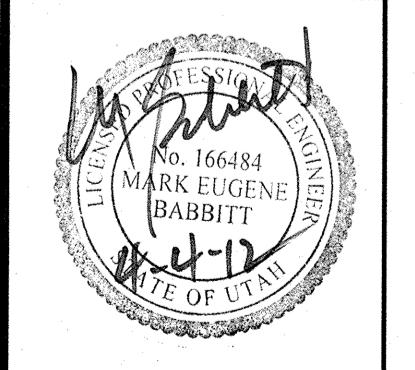

Jan, 2012

SHEET NO.

KM

96N120 Waterline

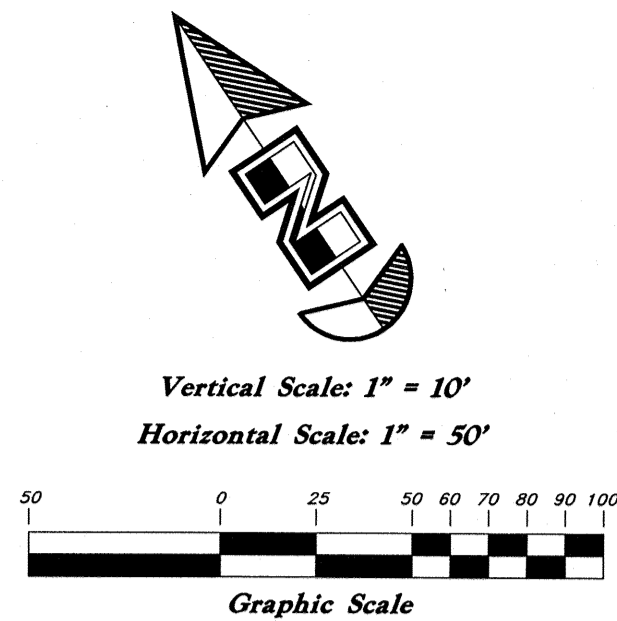

Legend

(Note: All items may not appear on drawing)

- San. Sewer Manhole
- Water Manhole
- Storm Drain Manhole
- Electrical Manhole
- Catch Basins
- Exist. Fire Hydrant
- Fire Hydrant
- Exist. Water Valve
- Water Valve
- Sanitary Sewer
- Culinary Water
- Gas Line
- Irrigation Line
- Storm Drain
- Telephone Line
- Secondary Waterline
- Power Line
- Fire Line
- Land Drain
- Power pole w/guy
- Light Pole
- Fence
- Flowline of ditch
- Overhead Power line
- Corrugated Metal Pipe
- Concrete Pipe
- Reinforced Concrete Pipe
- Ductile Iron
- PVC
- Polyvinyl Chloride
- Top of Asphalt
- Edge of Asphalt
- Centerline
- Flowline
- Finish Floor
- TC
- Top of Curb
- Top of Wall
- Top of Walk
- TCN
- Top of Concrete
- Natural Ground
- Finish Contour
- Exist. Contour
- Finish Grade
- Exist. Grade
- Ridge Line
- Direction of Flow
- Existing Asphalt
- New Asphalt
- Heavy Duty Asphalt
- Concrete
- Open Face Curb & Gutter

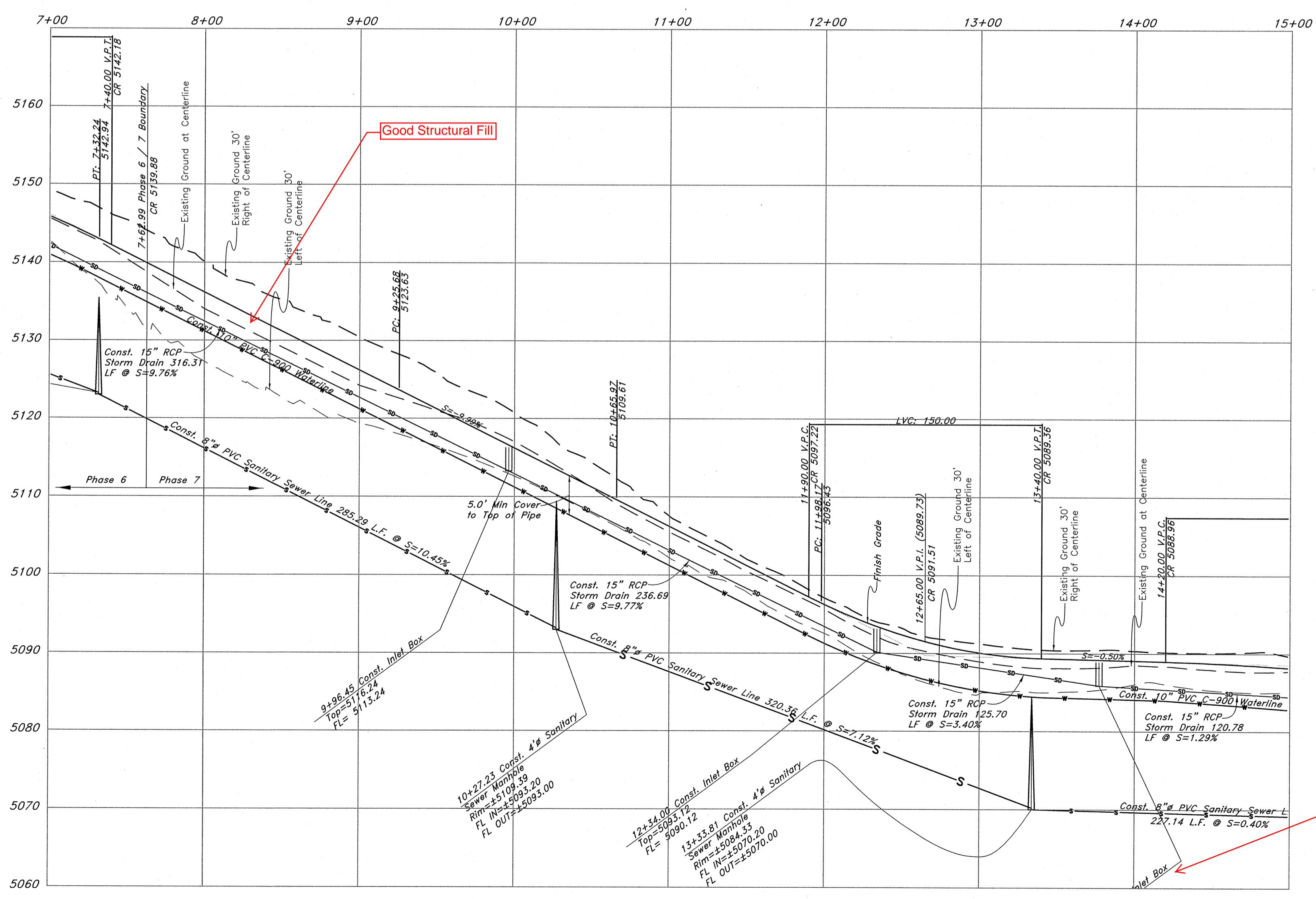
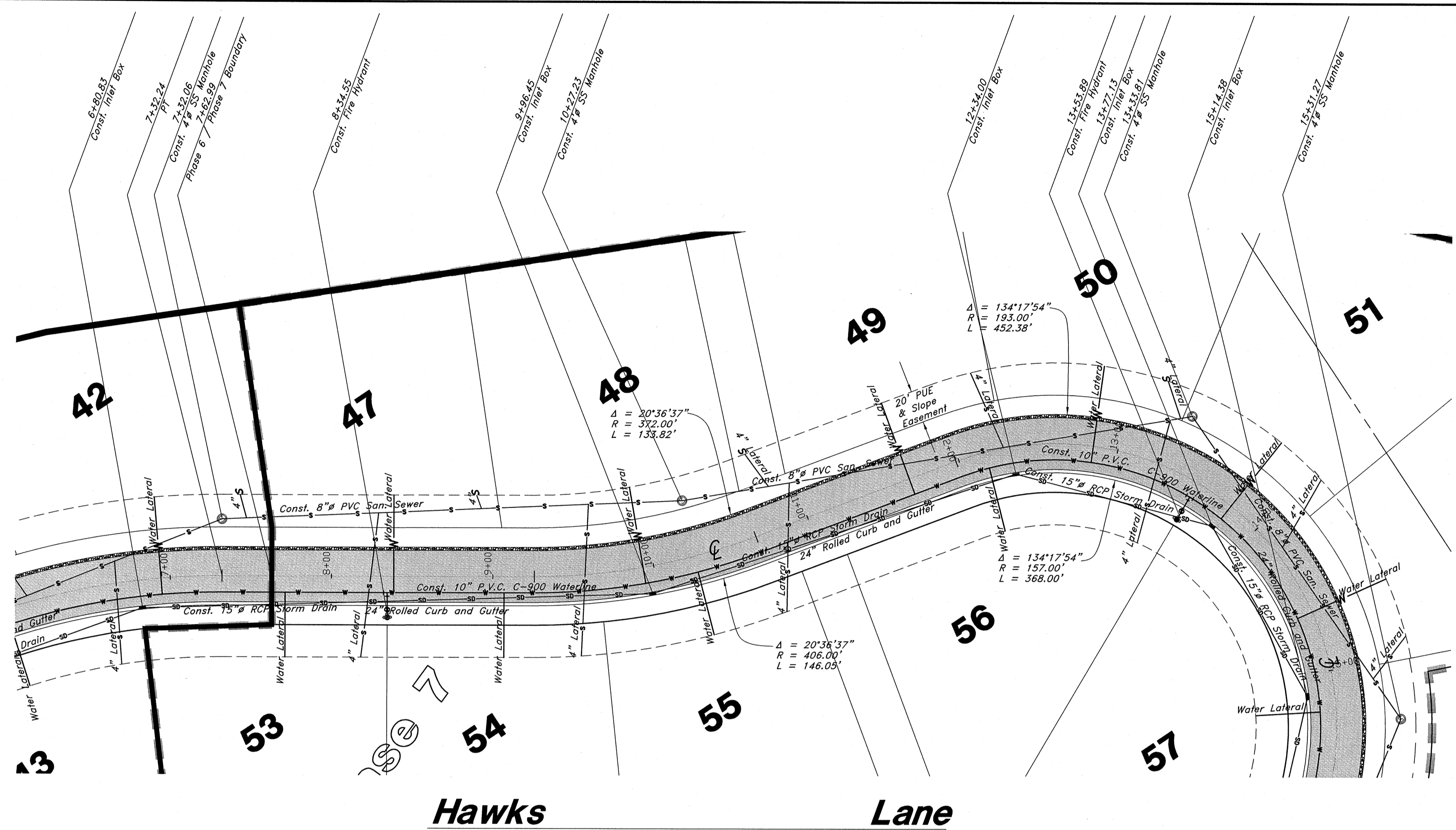

GREAT BASIN ENGINEERING

5746 SOUTH 1475 EAST OGDEN, UTAH 84403
 MAIN (801)394-4515 S.L.C. (801)521-0222 FAX (801)392-7544
 WWW.GREATBASINENGINEERING.COM

Plan / Profile (Utility)

The Chalets at Ski Lake No. 7

A part of the Southwest 1/4 of Section 13, a part of the Northeast 1/4 of Section 23, and a part of the Northwest 1/4 of Section 24, T6N, R1E, S18&M, U.S. Survey

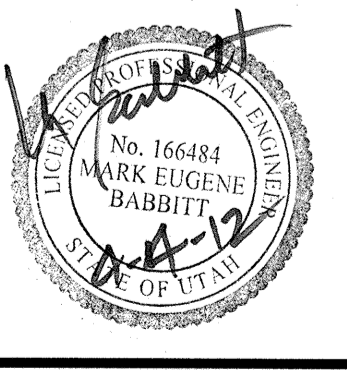

Jan, 2012

SHEET NO. **1**

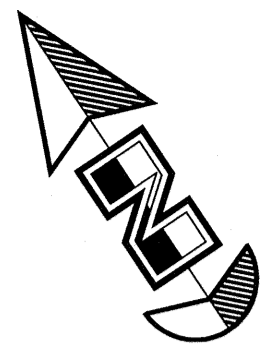

Vertical Scale: 1" = 10'
Horizontal Scale: 1" = 50'

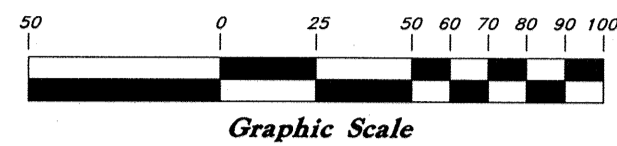

Legend

(Note: All items may not appear on drawing)

- San. Sewer Manhole
- Water Manhole
- Storm Drain Manhole
- Electrical Manhole
- Catch Basins
- Exist. Fire Hydrant
- Fire Hydrant
- Exist. Water Valve
- Water Valve
- Sanitary Sewer
- Culinary Water
- Gas Line
- Irrigation Line
- Storm Drain
- Telephone Line
- Secondary Waterline
- Power Line
- Fire Line
- Land Drain
- Power pole w/guy
- Light Pole
- Fence
- Flowline of ditch
- Overhead Power line
- Corrugated Metal Pipe
- Concrete Pipe
- Reinforced Concrete Pipe
- Ductile Iron
- PVC
- Polyvinyl Chloride
- Top of Asphalt
- Edge of Asphalt
- Centerline
- Flowline
- Finish Floor
- Top of Curb
- Top of Wall
- Top of Walk
- Top of Concrete
- Natural Ground
- Finish Contour
- Exist. Contour
- Finish Grade
- Exist. Grade
- Ridge Line
- Direction of Flow
- Existing Asphalt
- New Asphalt
- Heavy Duty Asphalt
- Concrete
- Open Face
- Curb & Gutter

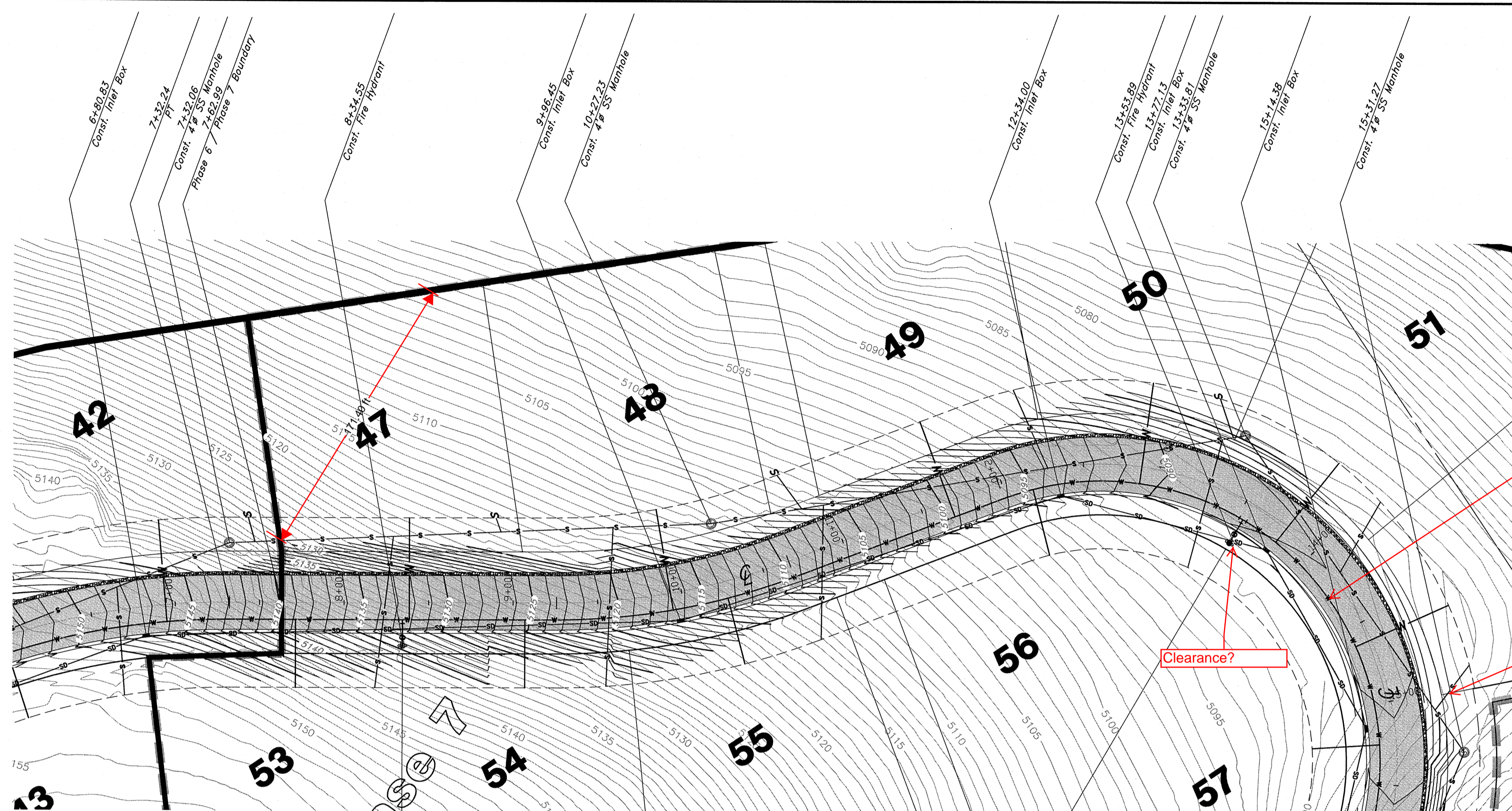

Benchmark: Monument at Intersection of Quail Lane and Meadow Lark Lane
Elevation: 5022.34

What is the min. bending radius on 10" pvc.

Clearance?

can lateral be shifted to avoid crossing lot?

Hawk Lane

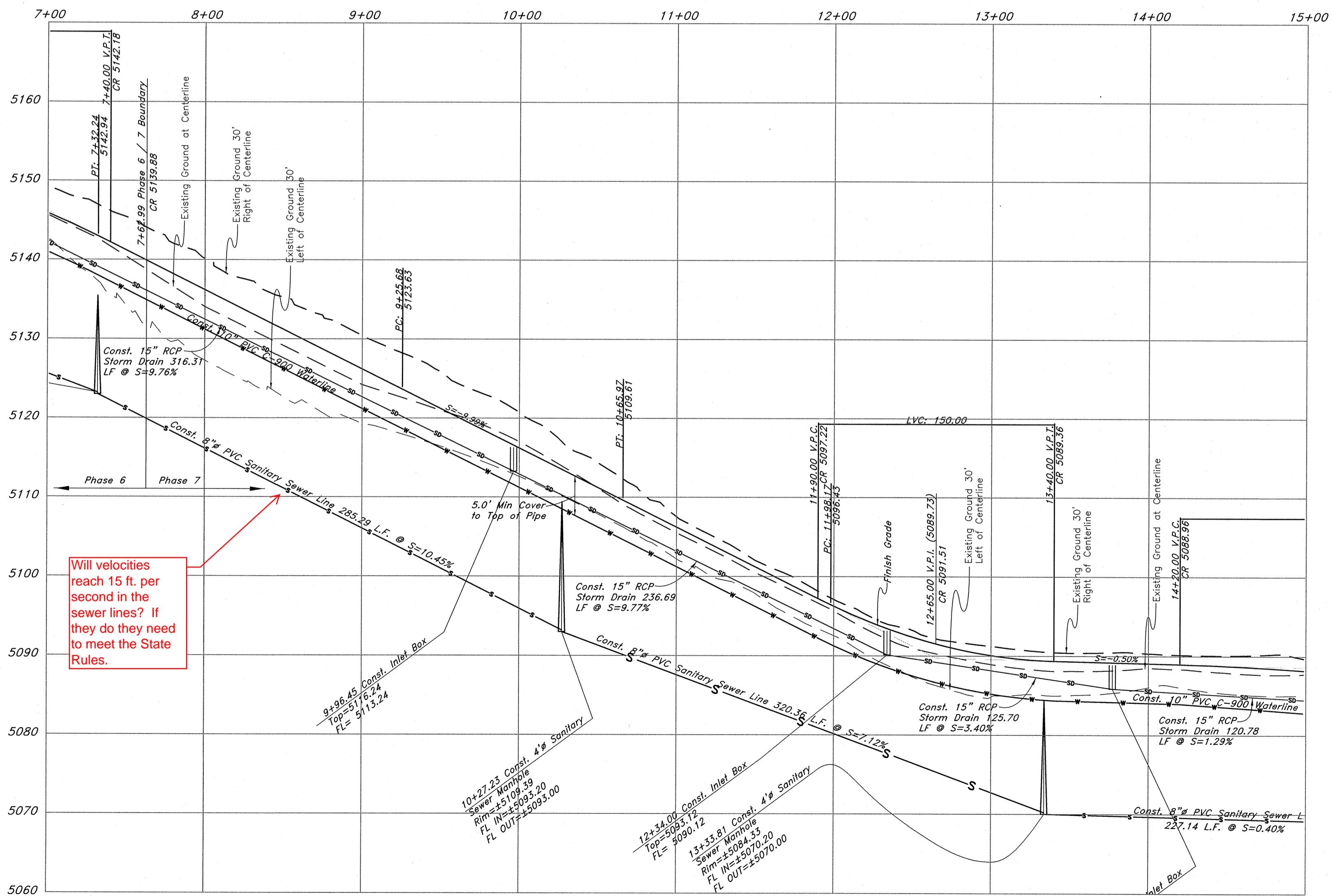

Will velocities reach 15 ft. per second in the sewer lines? If they do they need to meet the State Rules.

REV	DATE	DESCRIPTION

GREAT BASIN ENGINEERING

5746 SOUTH N. 1475 EAST OGDEN, UTAH 84409
 MAIN (801) 394-4515 SLLC (801) 521-0222 FAX (801) 392-7544
 WWW.GREATBASINENGINEERING.COM

Plan / Profile (Grading)

The Chalets at Ski Lake No. 7

A part of the Southwest 1/4 of Section 13, a part of the Northeast 1/4 of Section 23, and a part of the Northwest 1/4 of Section 24, T6N, R1E, SL&M, U.S. Survey

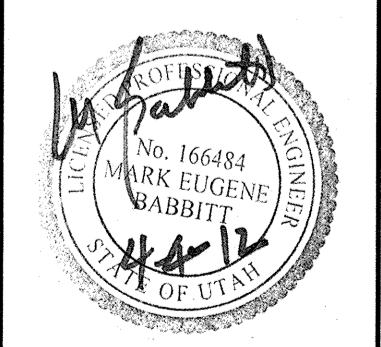

Jan, 2012

SHEET NO.

1a

96N120 Waterline

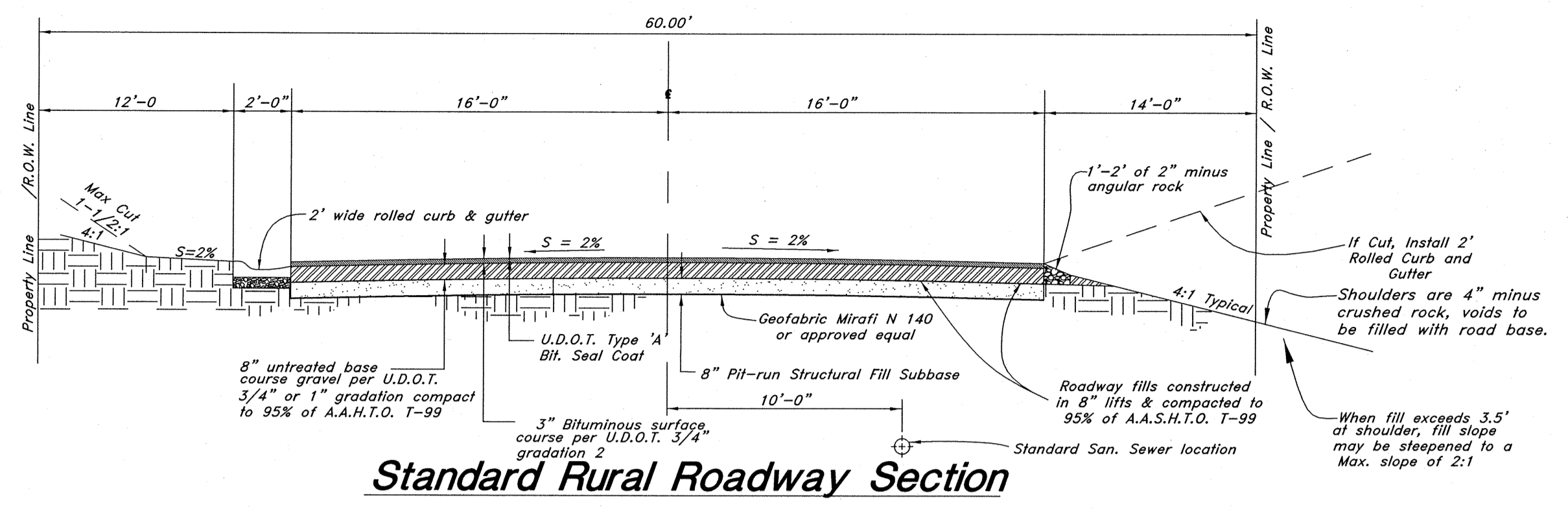
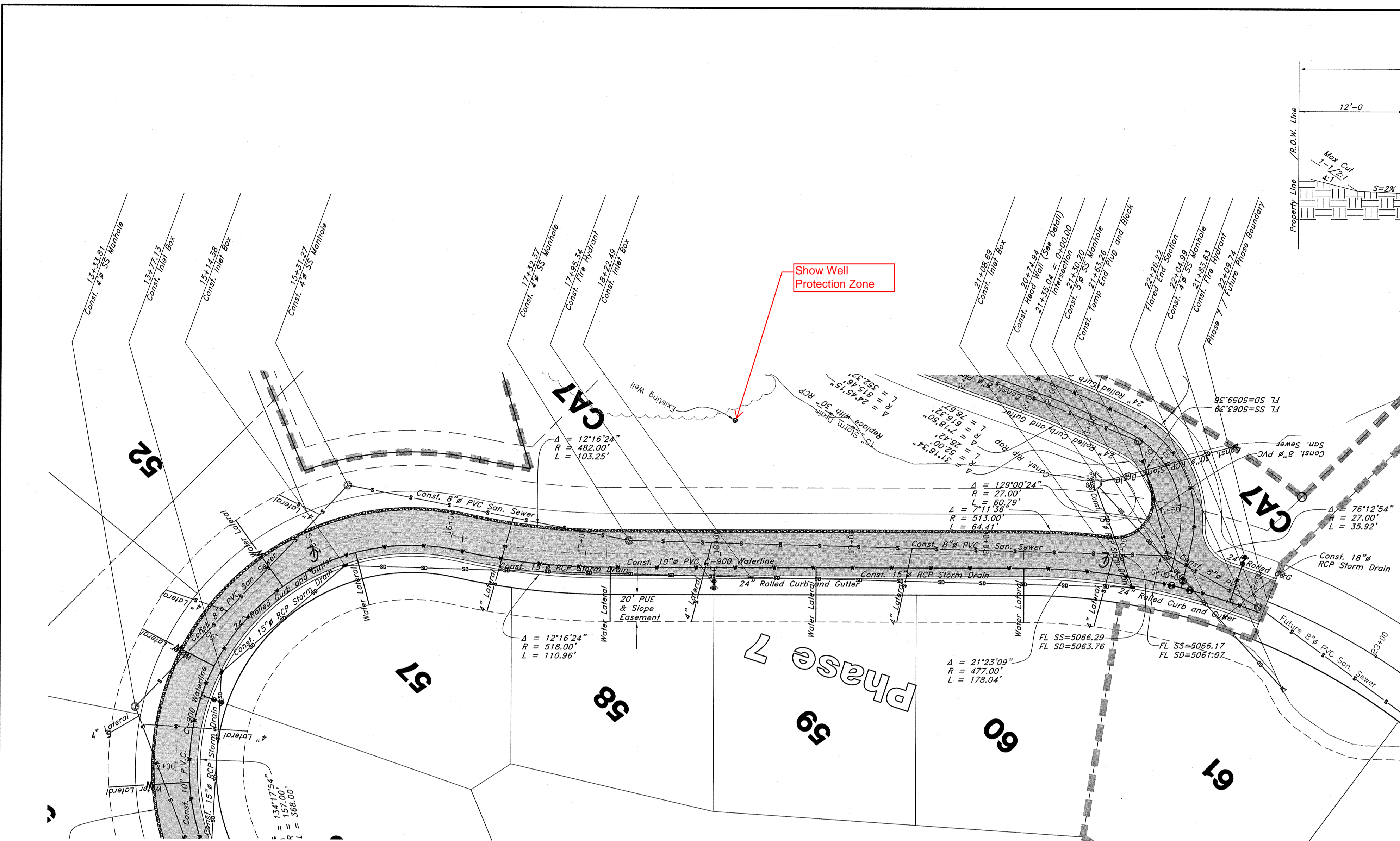

NOTE: TO PREVENT SOIL EROSION, PROTECT STEEP SLOPES WITH HYDROSEEDING OR EROSION CONTROL BLANKETS.

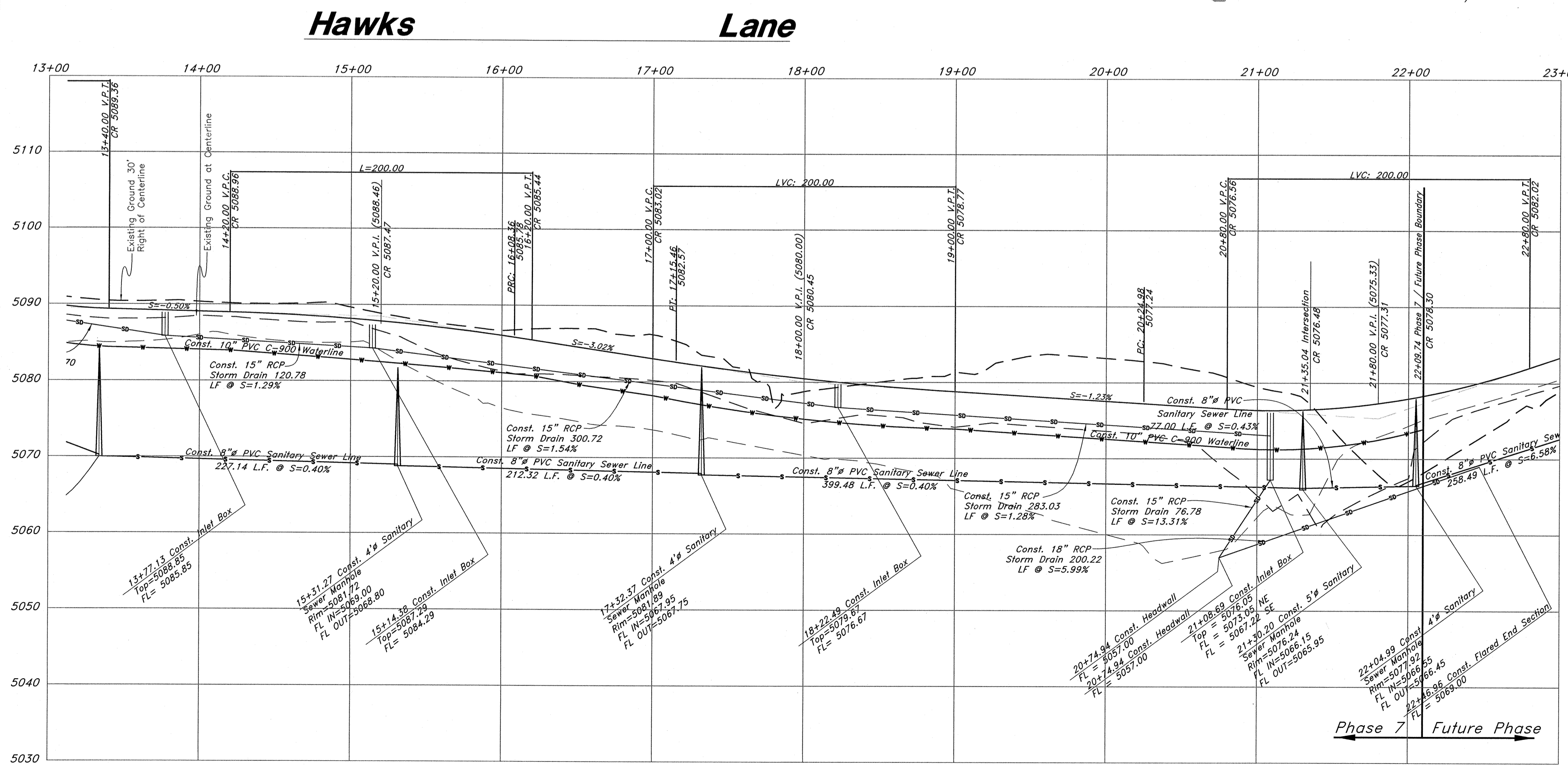
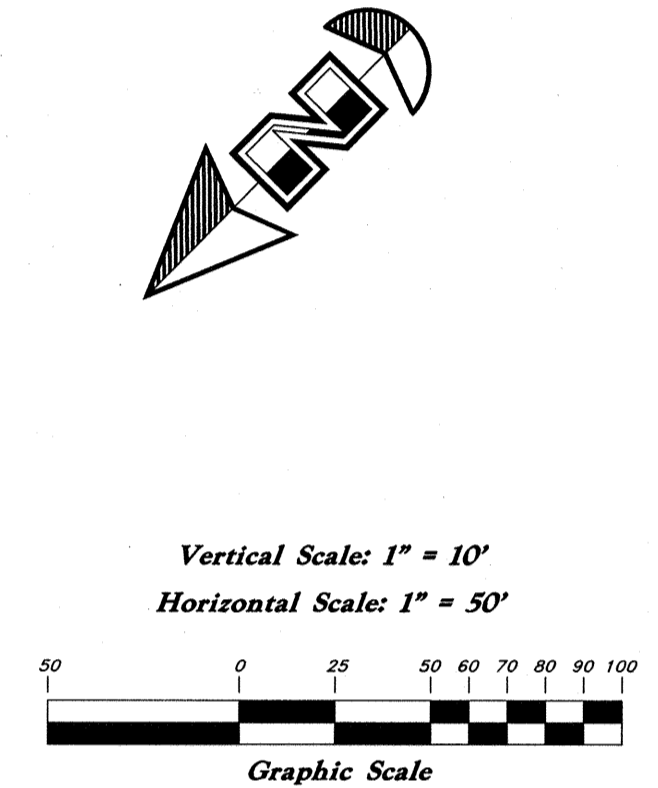

Legend

(Note: All items may not appear on drawing)

- San Sewer Manhole
- Water Manhole
- Storm Drain Manhole
- Electrical Manhole
- Catch Basins
- Exist. Fire Hydrant
- Fire Hydrant
- Exist. Water Valve
- Water Valve
- Sanitary Sewer
- Culinary Water
- Gas Line
- Irrigation Line
- Storm Drain
- Telephone Line
- Secondary Waterline
- Power Line
- Fire Line
- Land Drain
- Power pole
- Power pole w/guy
- Light Pole
- Fence
- Flowline of ditch
- Overhead Power line
- Corrugated Metal Pipe
- Concrete Pipe
- Reinforced Concrete Pipe
- Ductile Iron
- Polyvinyl Chloride
- Top of Asphalt
- Edge of Asphalt
- Centerline
- Flowline
- Finish Floor
- Top of Curb
- Top of Wall
- Top of Walk
- Top of Concrete
- Natural Ground
- Finish Contour
- Exist. Contour
- Finish Grade
- Exist. Grade
- Ridge Line
- Direction of Flow
- Existing Asphalt
- New Asphalt
- Heavy Duty Asphalt
- Concrete
- Open Face Curb & Gutter

GREAT BASIN ENGINEERING
 5746 SOUTH 1475 EAST, OGDEN, UTAH 84403
 (409) 451-5151 FAX (409) 592-7544
 WWW.GREATBASINENGINEERING.COM

Plan / Profile (Utility)
The Chalets at Ski Lake No. 7
 A part of the Southwest 1/4 of Section 13, a part of the Northeast 1/4 of Section 24, 1/4 of Section 23, and a part of the Northwest 1/4 of Section 24, T6N, R1E, SLB&M, U.S. Survey.

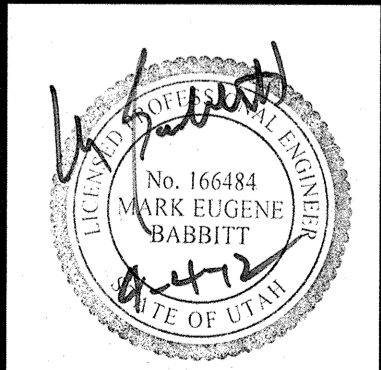

Jan, 2012

SHEET NO. **2**

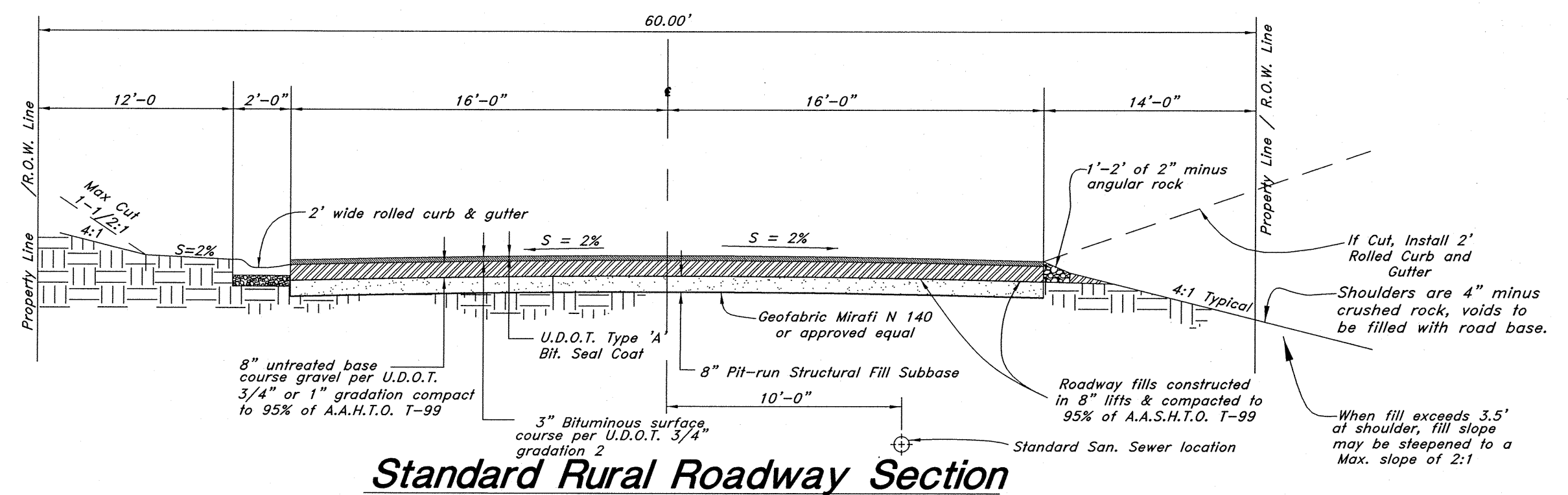
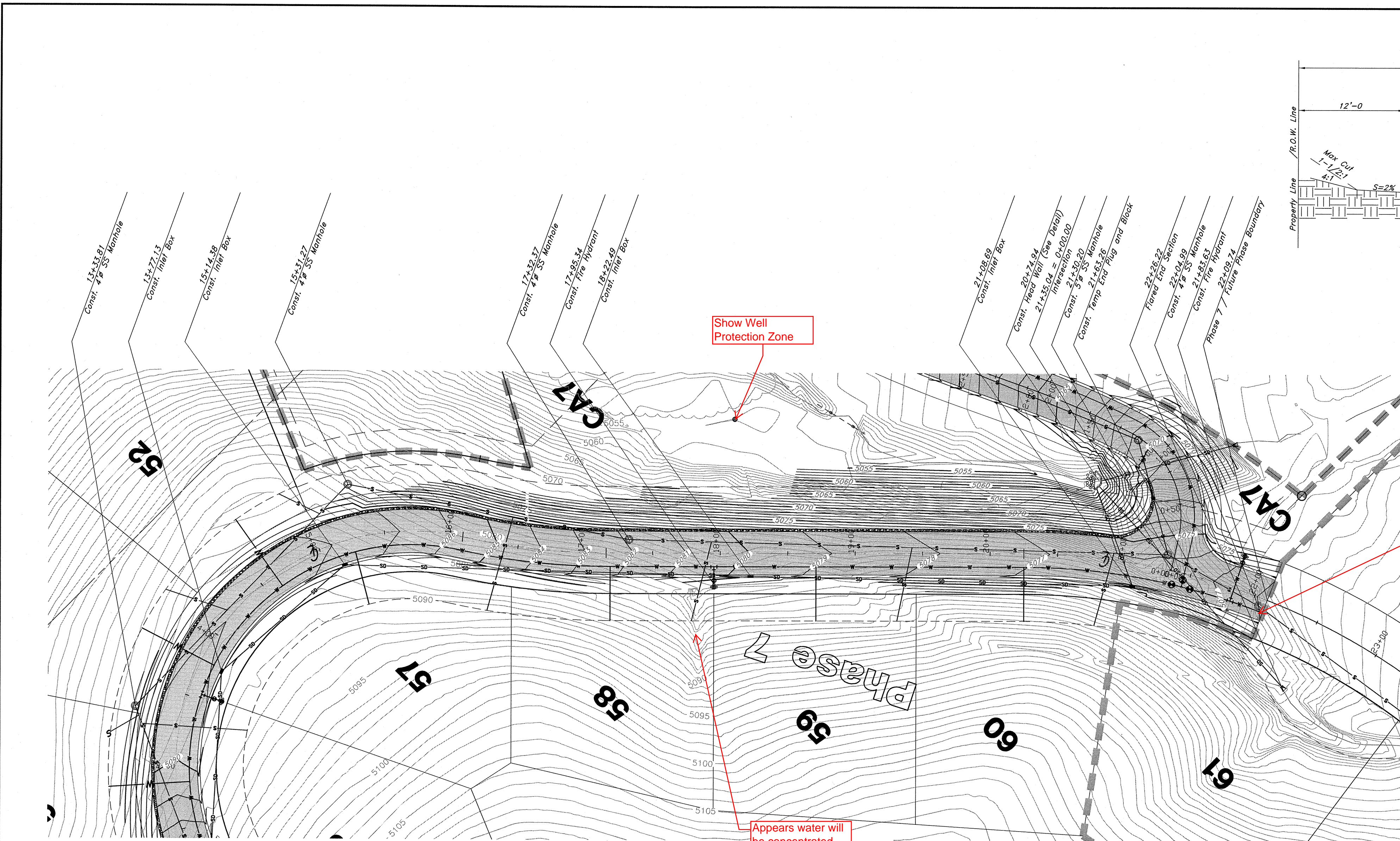

NOTE: TO PREVENT SOIL EROSION, PROTECT STEEP SLOPES WITH HYDROSEEDING OR EROSION CONTROL BLANKETS.

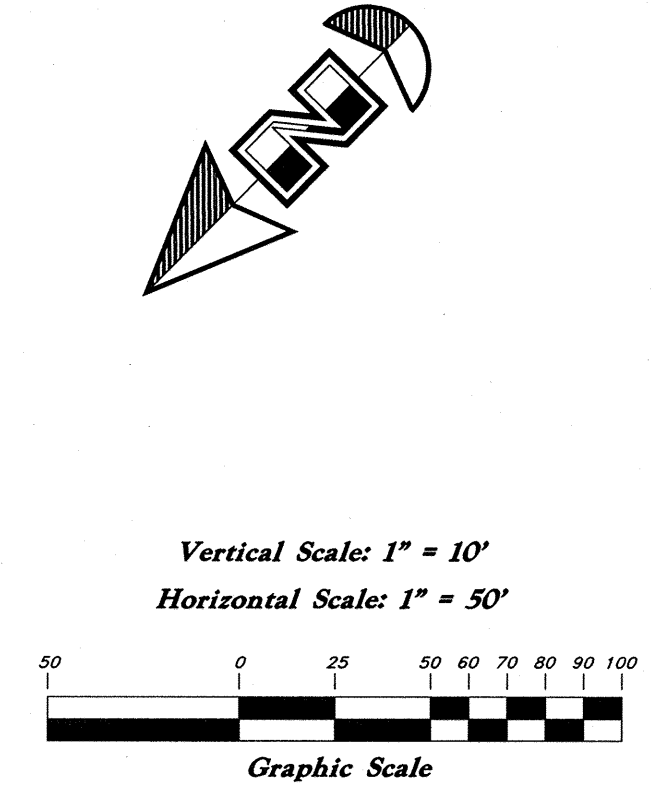

Legend

- (Note: All items may not appear on drawing)
- San. Sewer Manhole
 - Water Manhole
 - Storm Drain Manhole
 - Electrical Manhole
 - Catch Basins
 - Exist. Fire Hydrant
 - Fire Hydrant
 - Exist. Water Valve
 - Water Valve
 - Sanitary Sewer
 - Culinary Water
 - Gas Line
 - Irrigation Line
 - Storm Drain
 - Telephone Line
 - Secondary Waterline
 - Power Line
 - Fire Line
 - Land Drain
 - Power pole
 - Power pole w/guy
 - Light Pole
 - Fence
 - Flowline of ditch
 - Overhead Power line
 - Corrugated Metal Pipe
 - Concrete Pipe
 - Reinforced Concrete Pipe
 - Ductile Iron
 - Polyvinyl Chloride
 - Top of Asphalt
 - Edge of Asphalt
 - Centerline
 - Flowline
 - Finish Floor
 - Top of Curb
 - Top of Wall
 - Top of Concrete
 - Natural Ground
 - Finish Contour
 - Exist. Contour
 - Finish Grade
 - Exist. Grade
 - Ridge Line
 - Direction of Flow
 - Existing Asphalt
 - New Asphalt
 - Heavy Duty Asphalt
 - Concrete
 - Open Face
 - Curb & Gutter

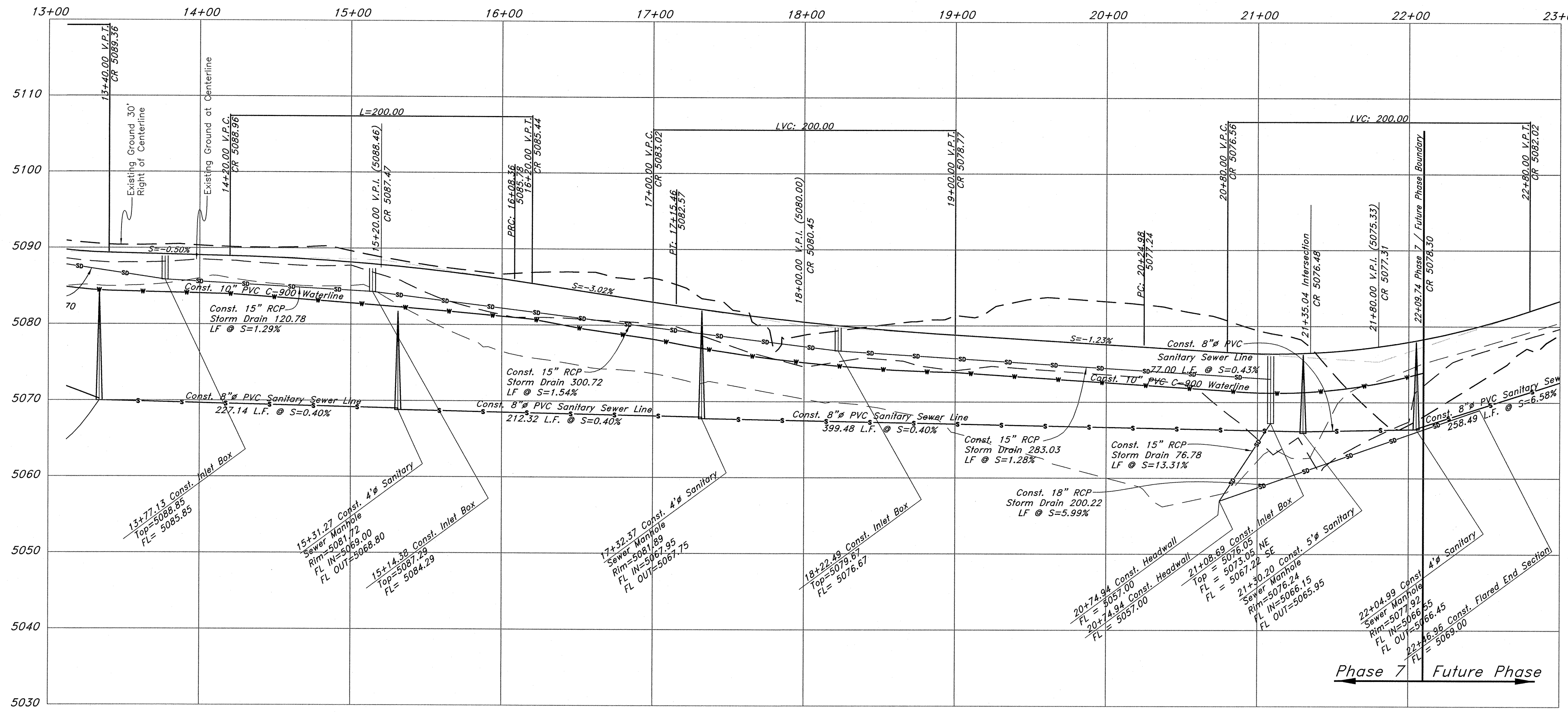

GREAT BASIN ENGINEERING

95.33TA
95.72TA

5746 SOUTH 1475 EAST, OGDEN, UTAH 84403
WWW.GREATBASINENGINEERING.UGM

Plan / Profile (Grading)

The Chalets at Ski Lake No. 7

A part of the Southwest 1/4 of Section 13, a part of the Northeast 1/4 of Section 23, and a part of the Northwest 1/4 of Section 24, T6N, R1E, S188M, U.S. Survey

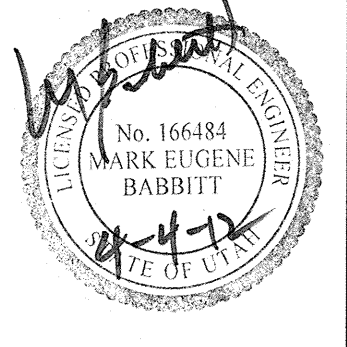

Jan, 2012

SHEET NO.

2a

96N120 Waterline

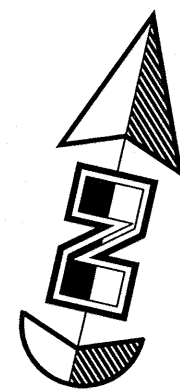

Vertical Scale: 1" = 10'
Horizontal Scale: 1" = 50'

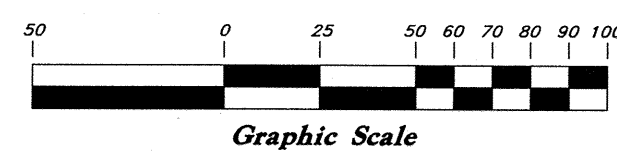

Legend

(Note: All items may not appear on drawing)

- San. Sewer Manhole
- Water Manhole
- Storm Drain Manhole
- Electrical Manhole
- Catch Basins
- Exist. Fire Hydrant
- Fire Hydrant
- Exist. Water Valve
- Water Valve
- Sanitary Sewer
- Culinary Water
- Gas Line
- Irrigation Line
- Storm Drain
- Telephone Line
- Secondary Waterline
- Power Line
- Fire Line
- Land Drain
- Power pole w/guy
- Light Pole
- Fence
- Flowline of ditch
- Overhead Power line
- Corrugated Metal Pipe
- Concrete Pipe
- Reinforced Concrete Pipe
- Ductile Iron
- PVC
- Polyvinyl Chloride
- Top of Asphalt
- Edge of Asphalt
- Centerline
- Flowline
- Finish Floor
- Top of Curb
- Top of Wall
- Top of Walk
- Top of Concrete
- Natural Ground
- Finish Contour
- Exist. Contour
- Finish Grade
- Exist. Grade
- Ridge Line
- Direction of Flow
- Existing Asphalt
- New Asphalt
- Heavy Duty Asphalt
- Concrete
- Open Face
- Curb & Gutter

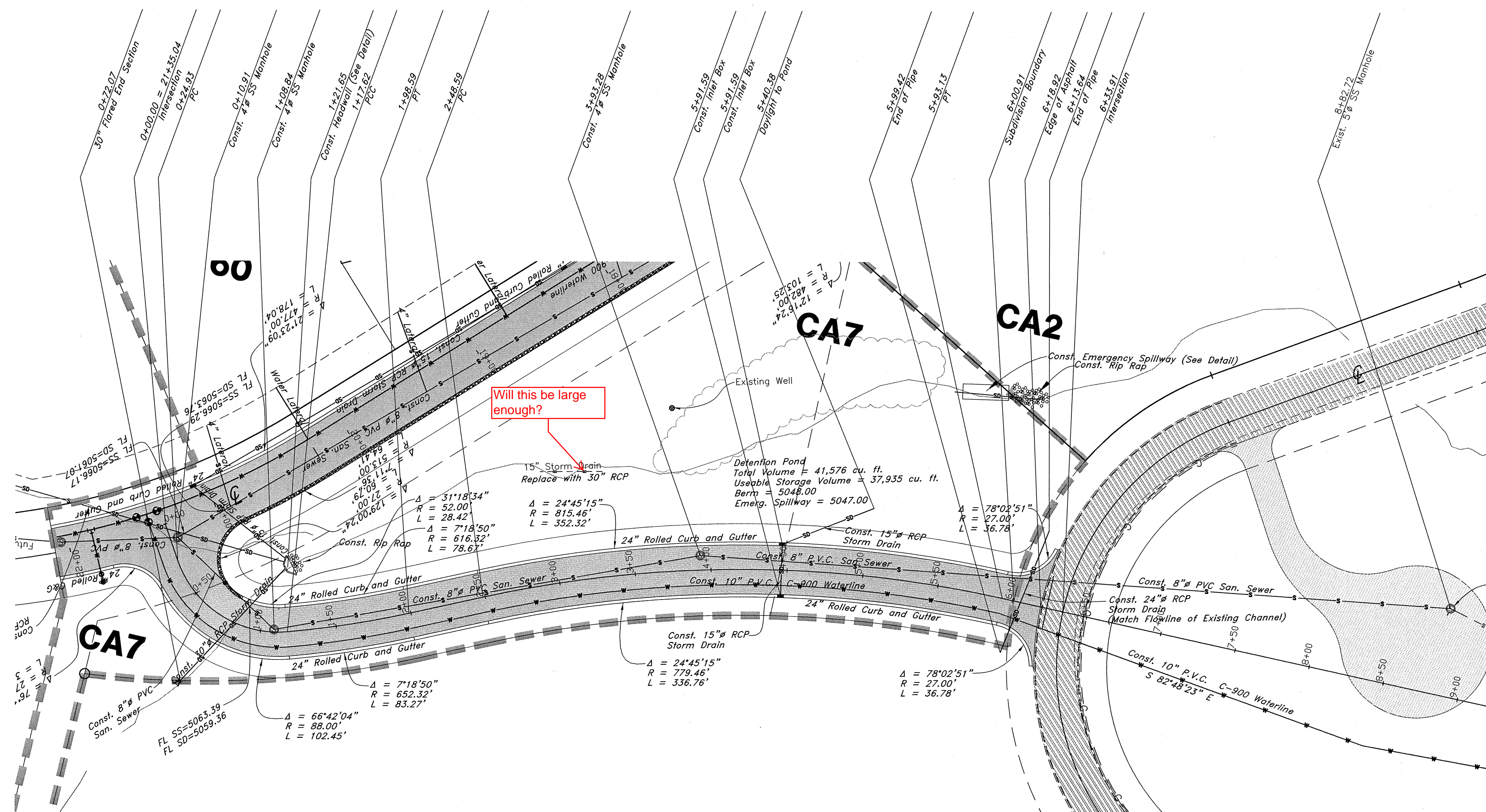

NOTE: TO PREVENT SOIL EROSION, PROTECT STEEP SLOPES WITH HYDROSEEDING OR EROSION CONTROL BLANKETS.

Emergency Access Road

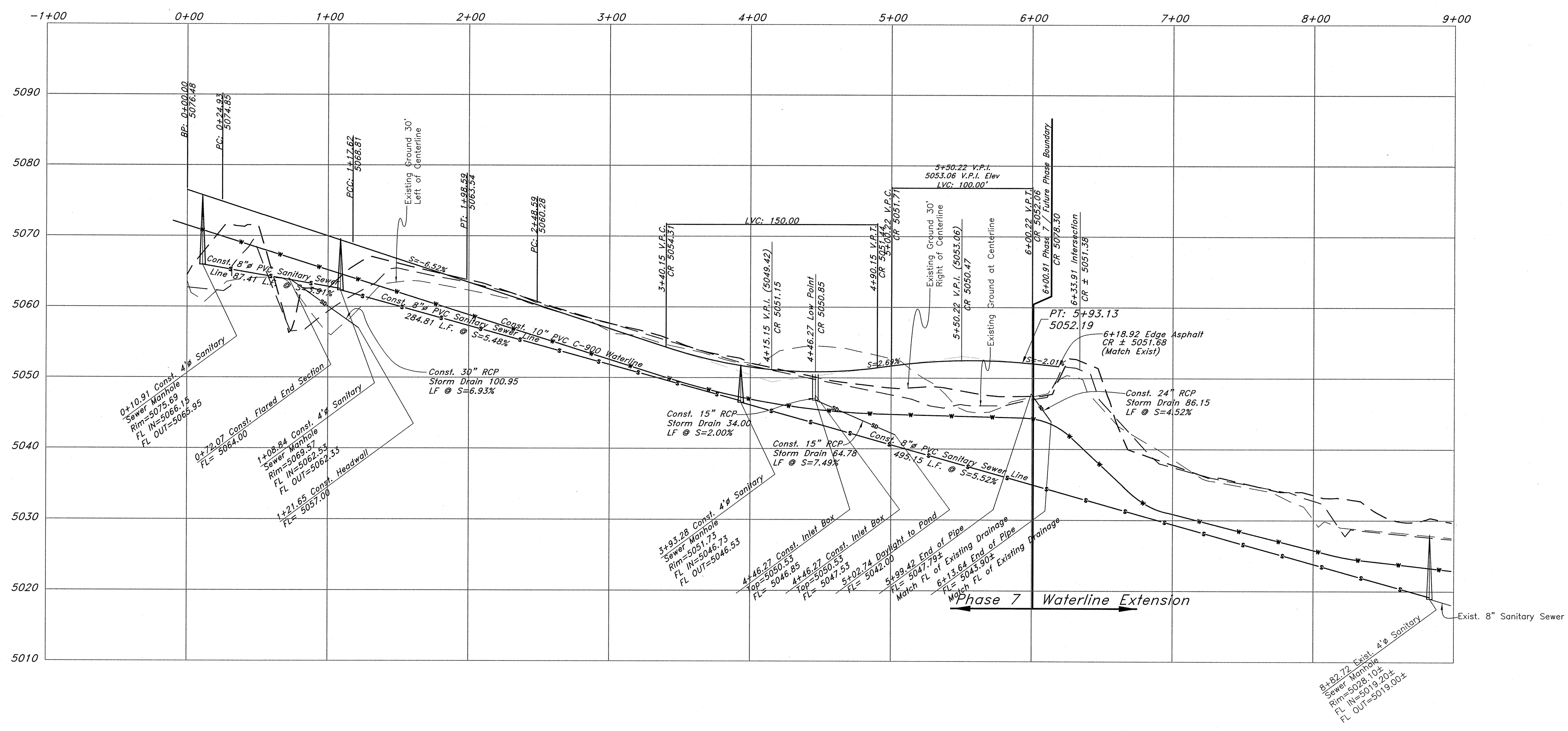

NO.	DESCRIPTION	DATE	REV.

GREAT BASIN ENGINEERING

5746 S. OULM 1475 E. EAST OGDEN, UTAH 84403
 MAIN (801) 394-4515 FAX (801) 392-7544
 WWW.GREATBASINENGINEERING.COM

Plan / Profile (Utility)

The Chalets at Ski Lake No. 7

A part of the Southwest 1/4 of Section 13, a part of the Northeast 1/4 of Section 23, and a part of the Northwest 1/4 of Section 24, T6N, R1E, SL&M, U.S. Survey

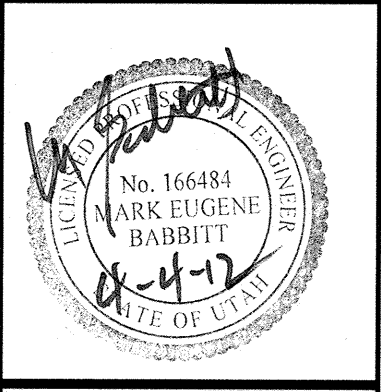

Jan, 2012

SHEET NO. **3**

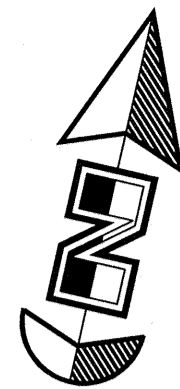

Vertical Scale: 1" = 10'
Horizontal Scale: 1" = 50'

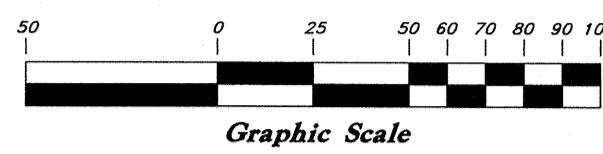

Legend

(Note: All items may not appear on drawing)

- San. Sewer Manhole
- Water Manhole
- Storm Drain Manhole
- Electrical Manhole
- Catch Basins
- Exist. Fire Hydrant
- Fire Hydrant
- Exist. Water Valve
- Water Valve
- Sanitary Sewer
- Culinary Water
- Gas Line
- Irrigation Line
- Storm Drain
- Telephone Line
- Secondary Waterline
- Power Line
- Fire Line
- Land Drain
- Power pole w/guy
- Light Pole
- Fence
- Flowline of ditch
- Overhead Power line
- Corrugated Metal Pipe
- Concrete Pipe
- RCP
- Reinforced Concrete Pipe
- Ductile Iron
- Polyvinyl Chloride
- Top of Asphalt
- Edge of asphalt
- Centerline
- Flowline
- Finish Floor
- Top of Curb
- Top of Wall
- Top of Walk
- TCN
- NG
- Finish Contour
- Exist. Contour
- Finish Grade
- Exist. Grade
- Ridge Line
- Direction of Flow
- Existing Asphalt
- New Asphalt
- Heavy Duty Asphalt
- Concrete
- Open Face
- Curb & Gutter

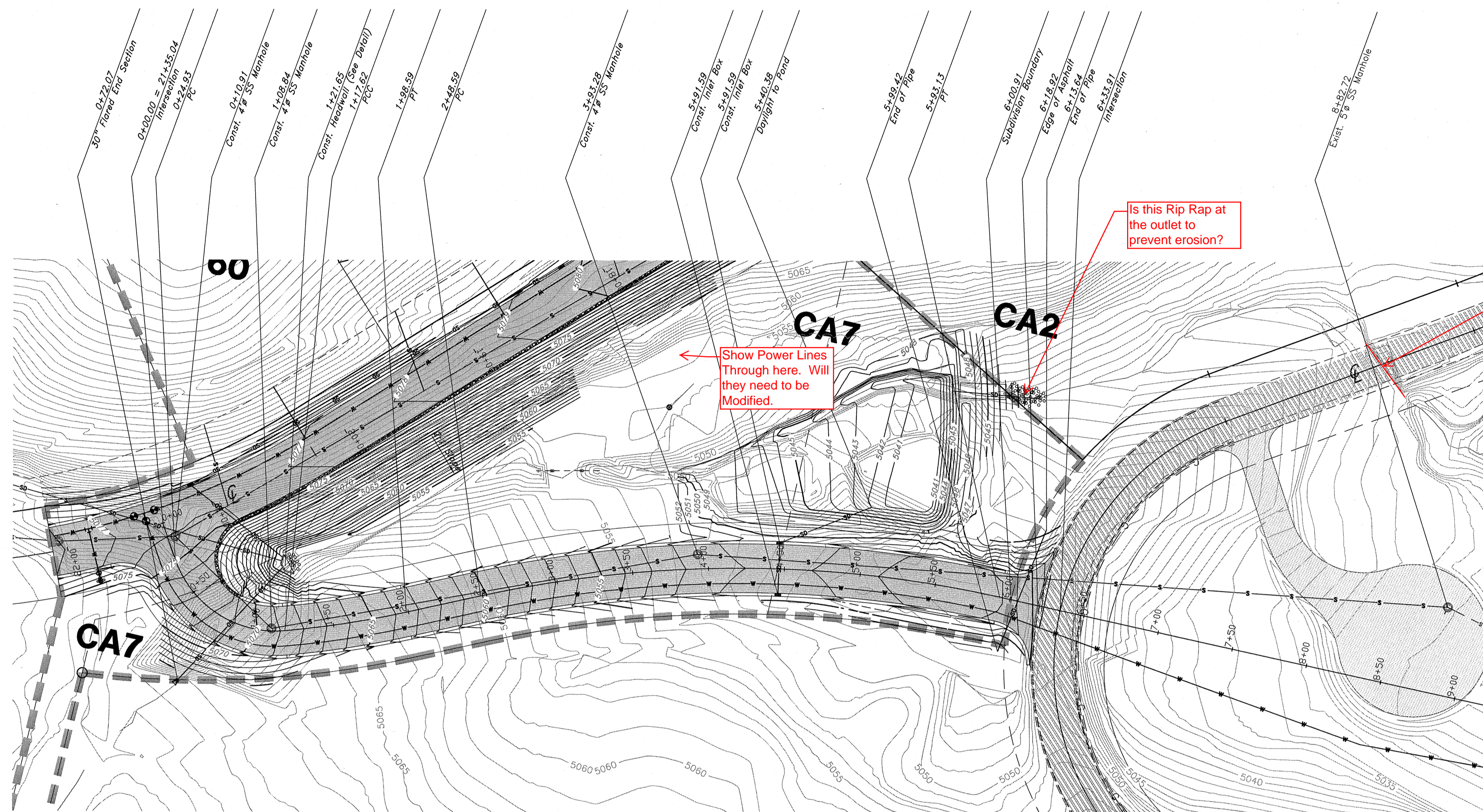

NOTE: TO PREVENT SOIL EROSION, PROTECT STEEP SLOPES WITH HYDROSEEDING OR EROSION CONTROL BLANKETS.

Emergency Access Road

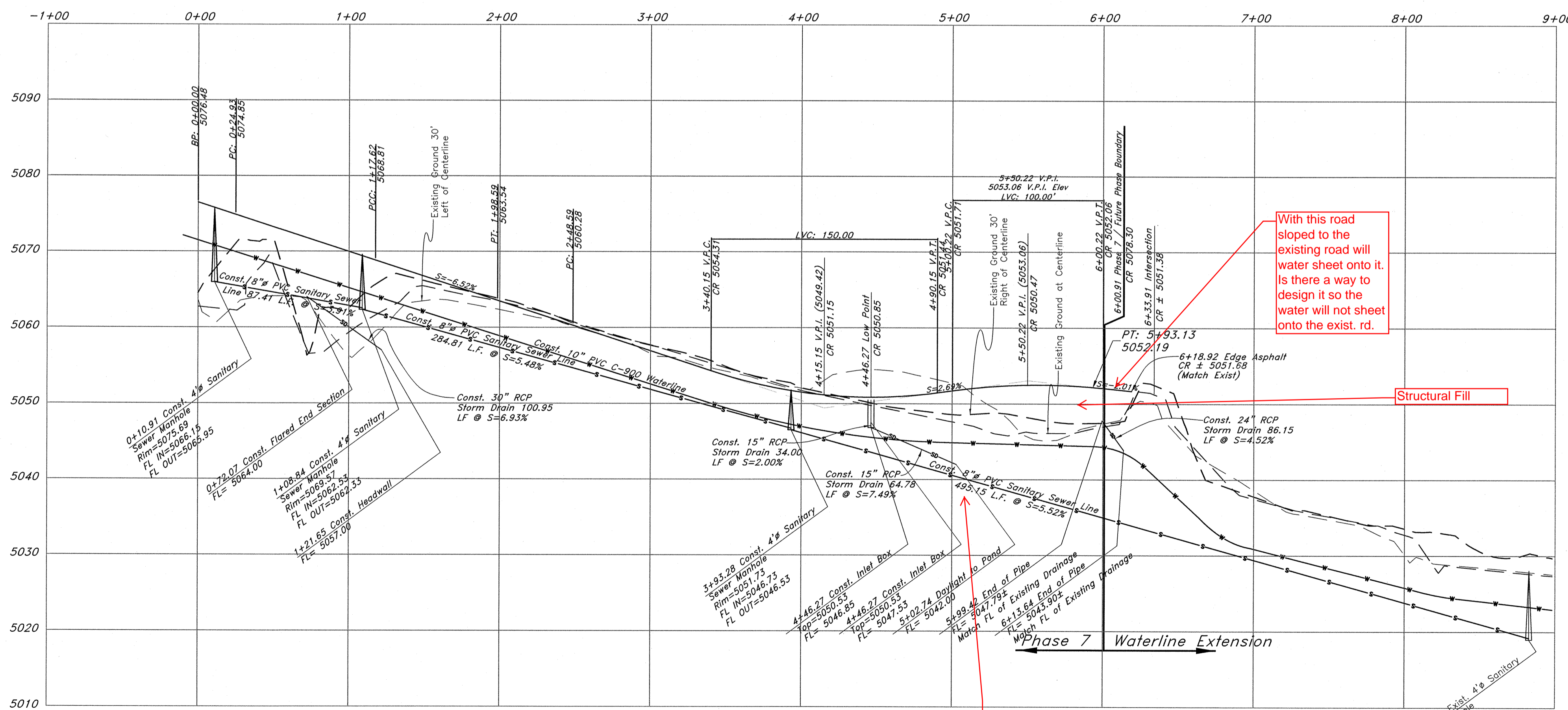

REV	DATE	DESCRIPTION

GREAT BASIN ENGINEERING

574 SOUTH 1475 EAST, SUITE 10222, SALT LAKE CITY, UT 84143
 MAIN (801) 391-4515, FAX (801) 392-7544
 WWW.GREATBASINENGINEERING.COM

Plan / Profile (Grading)

The Chalets at Ski Lake No. 7

A part of the Southwest 1/4 of Section 13, a part of the Northeast 1/4 of Section 23, and a part of the Northwest 1/4 of Section 24, T6N, R1E, S18E, U.S. Survey.

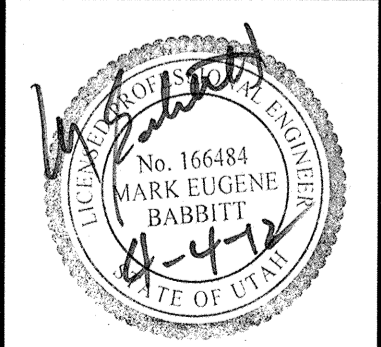

Jan, 2012

SHEET NO. **3a**

96N120 Waterline

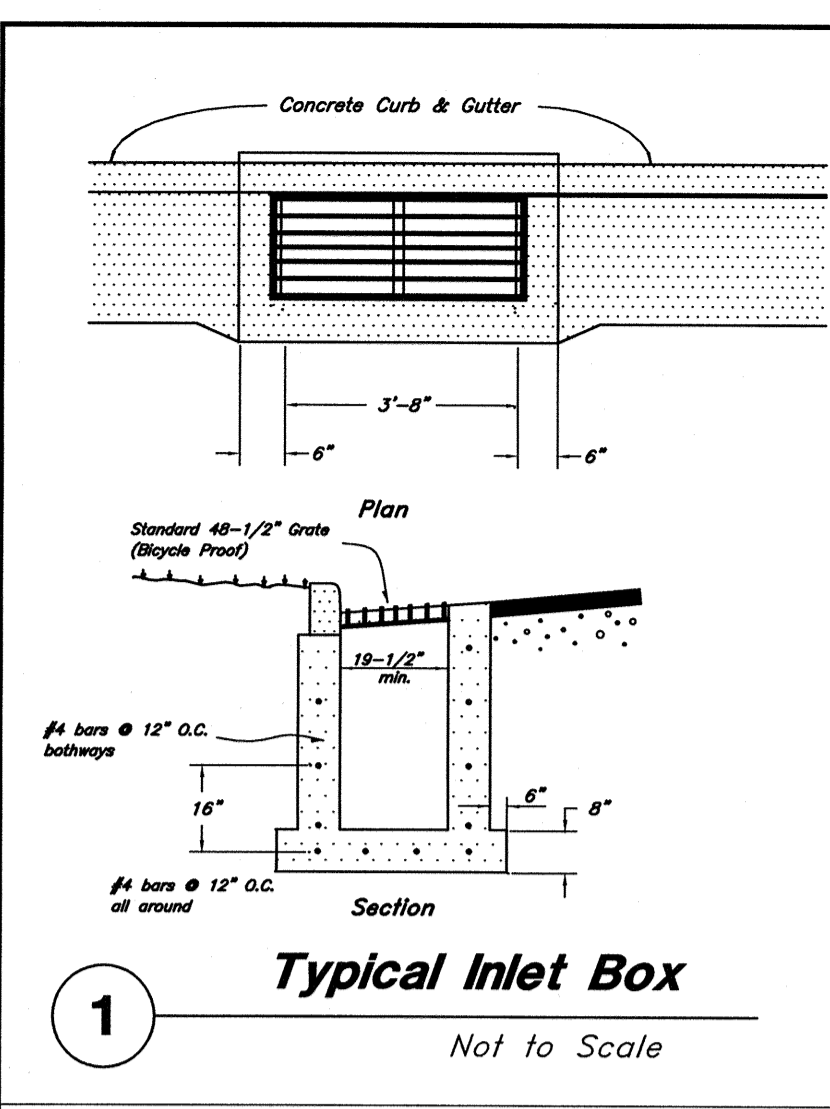

1 Typical Inlet Box
Not to Scale

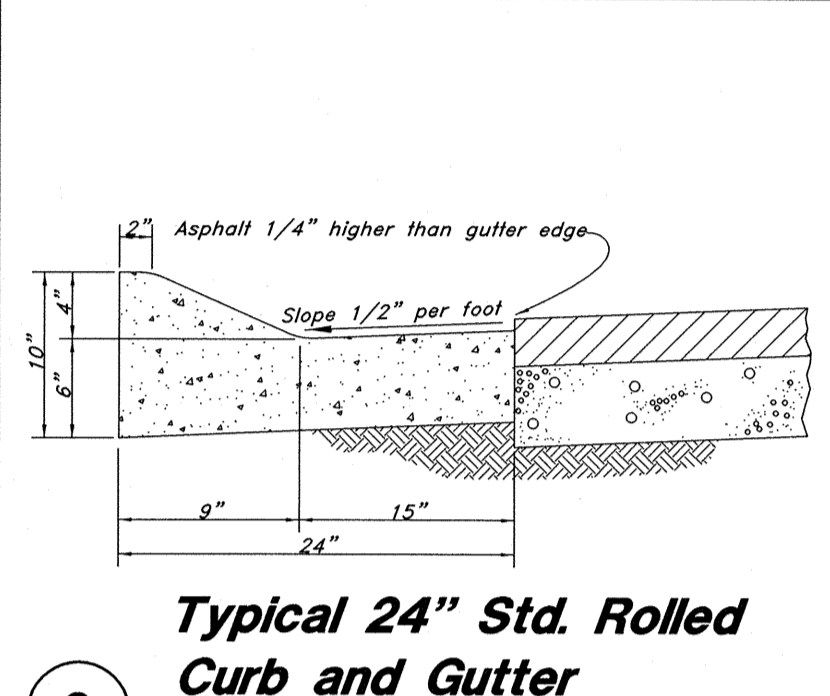

2 Typical 24\"/>Std. Rolled Curb and Gutter
Not to Scale

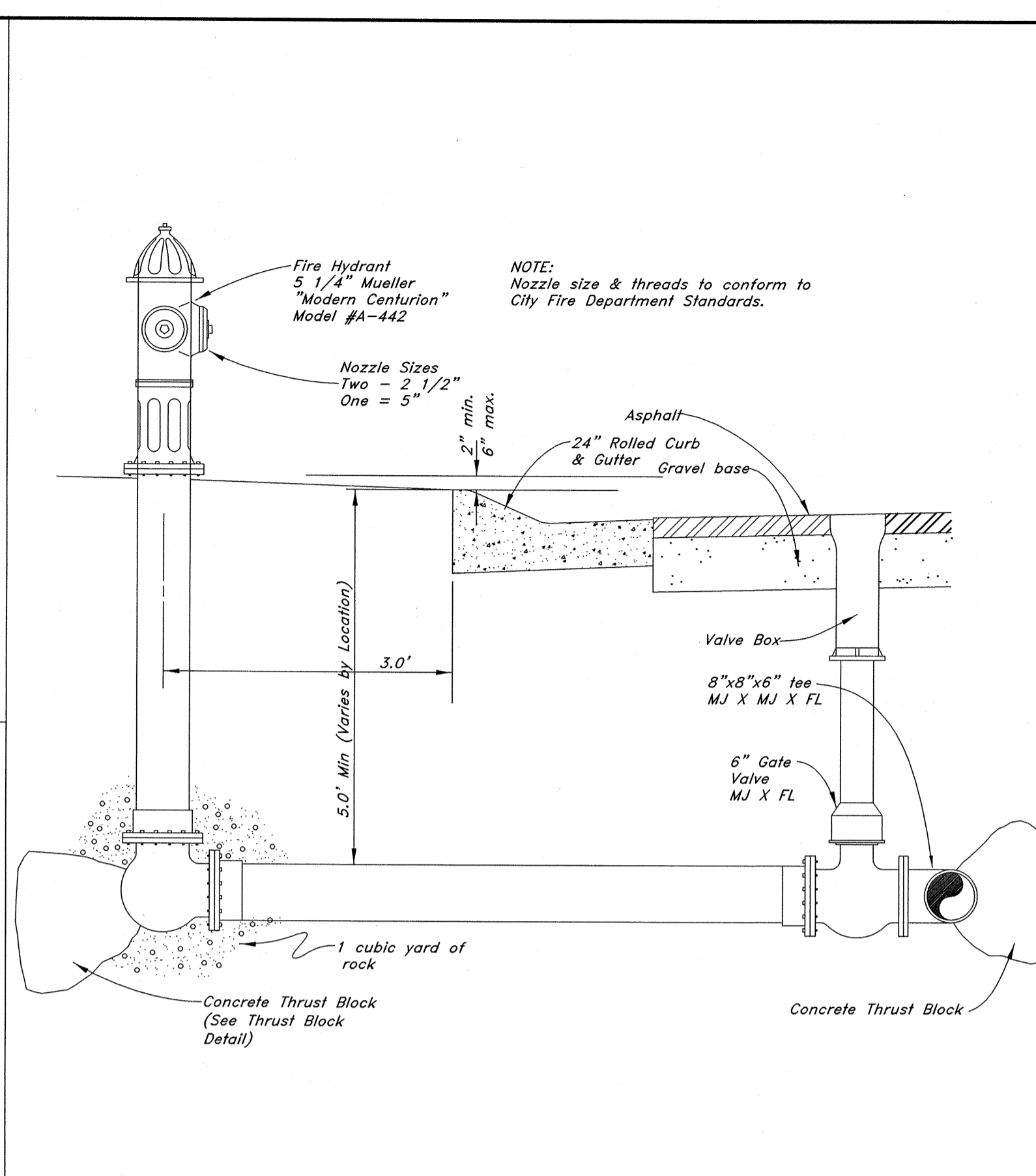

3 Typical Fire Hydrant & Valve Connection
Not to Scale

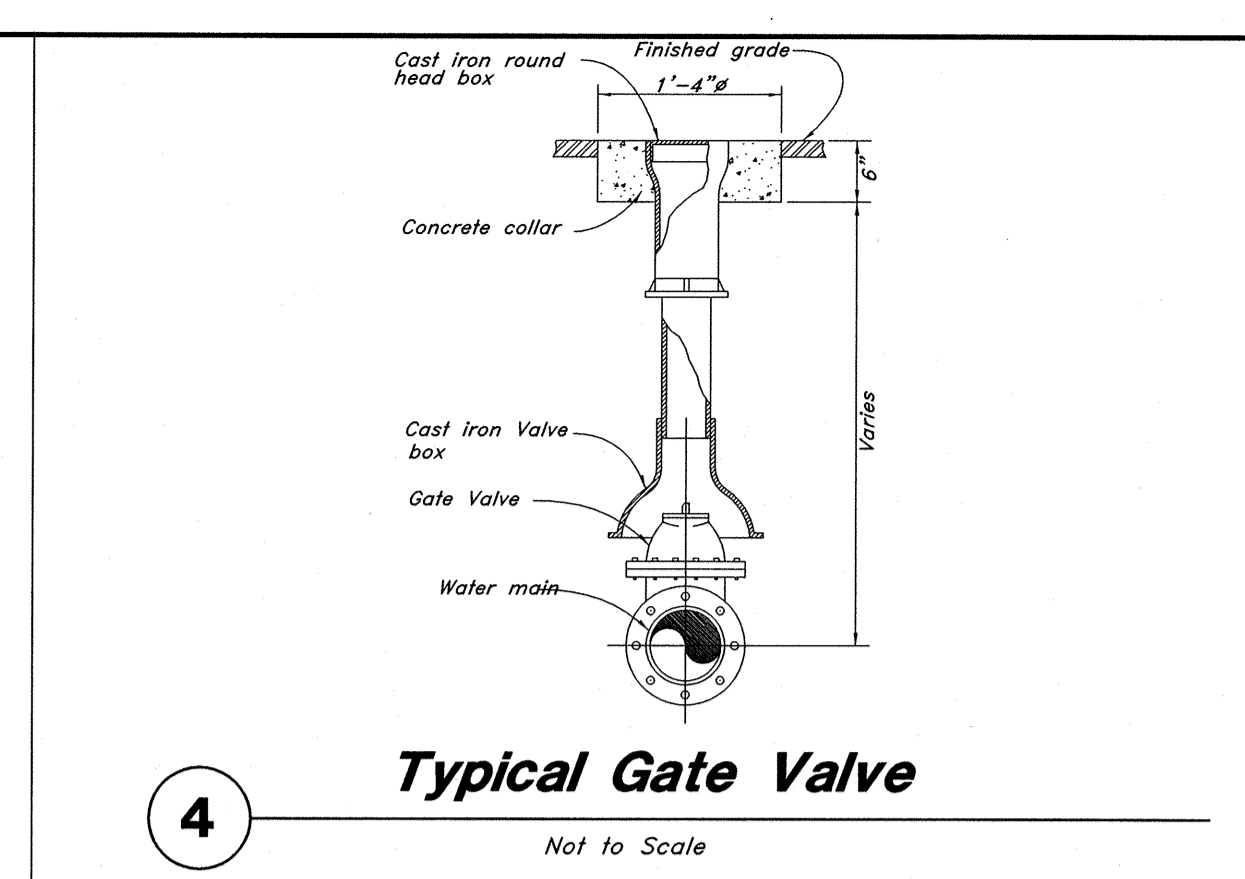

4 Typical Gate Valve
Not to Scale

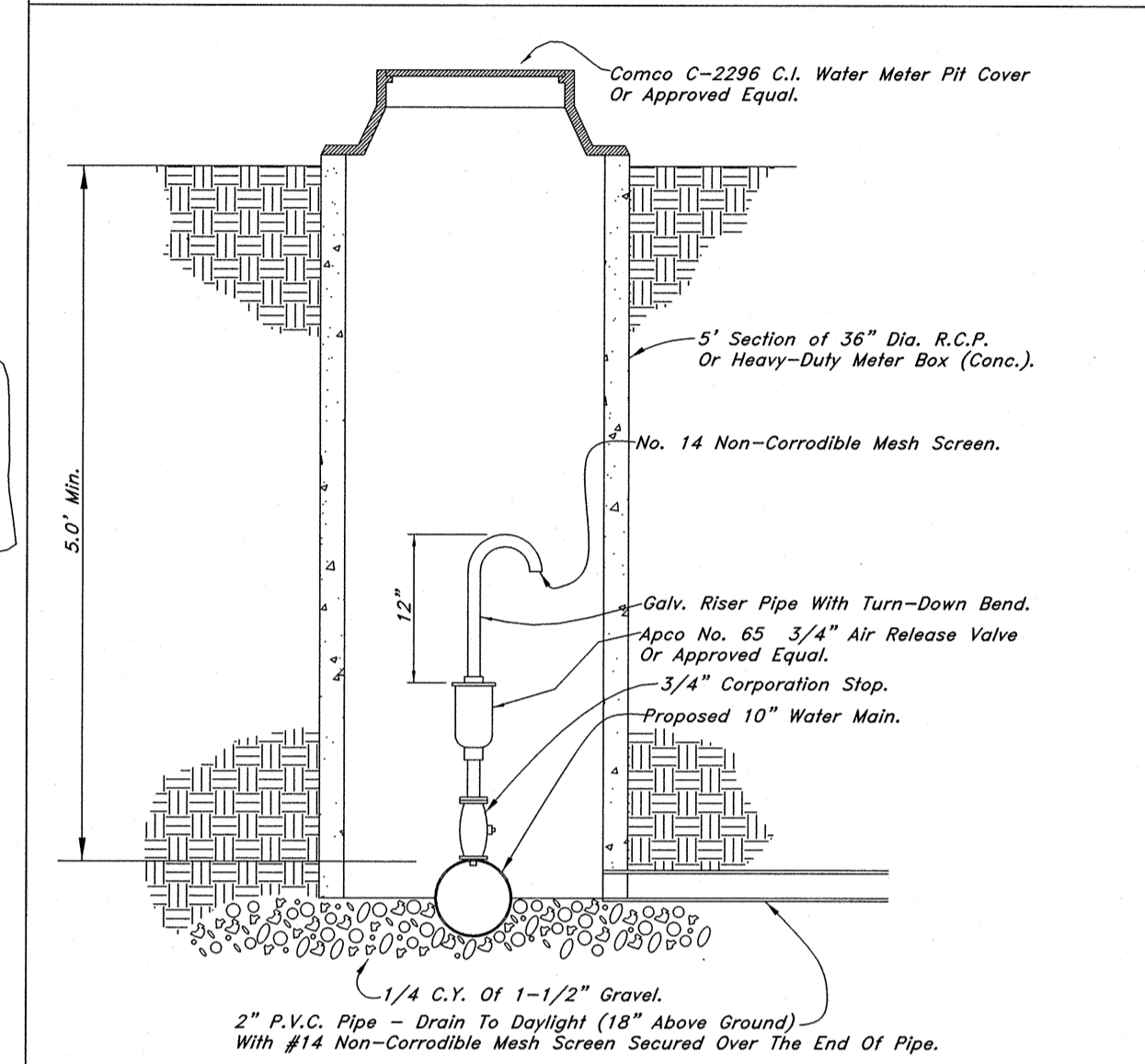

5 Air Release Detail
Not to Scale

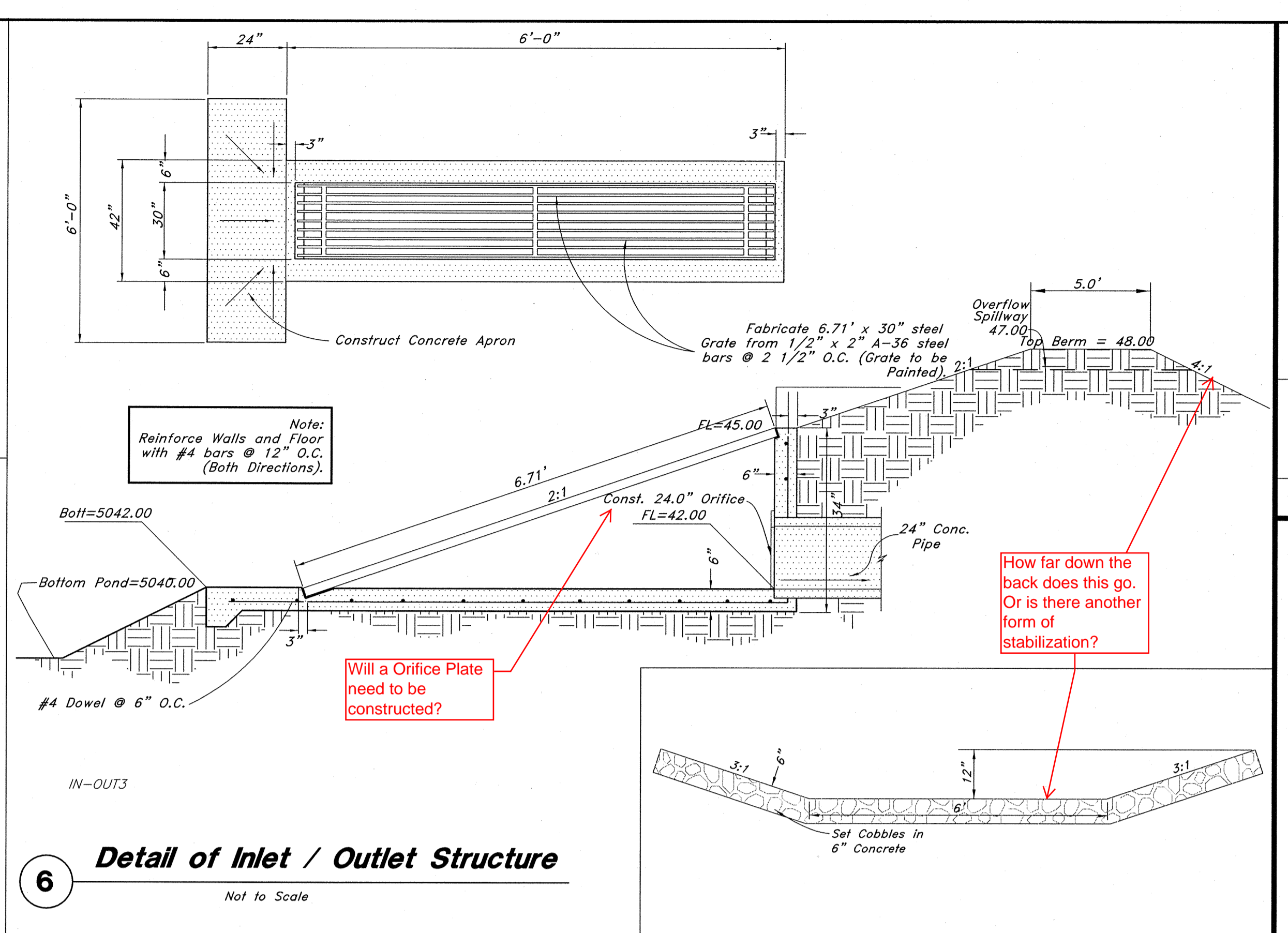

6 Detail of Inlet / Outlet Structure
Not to Scale

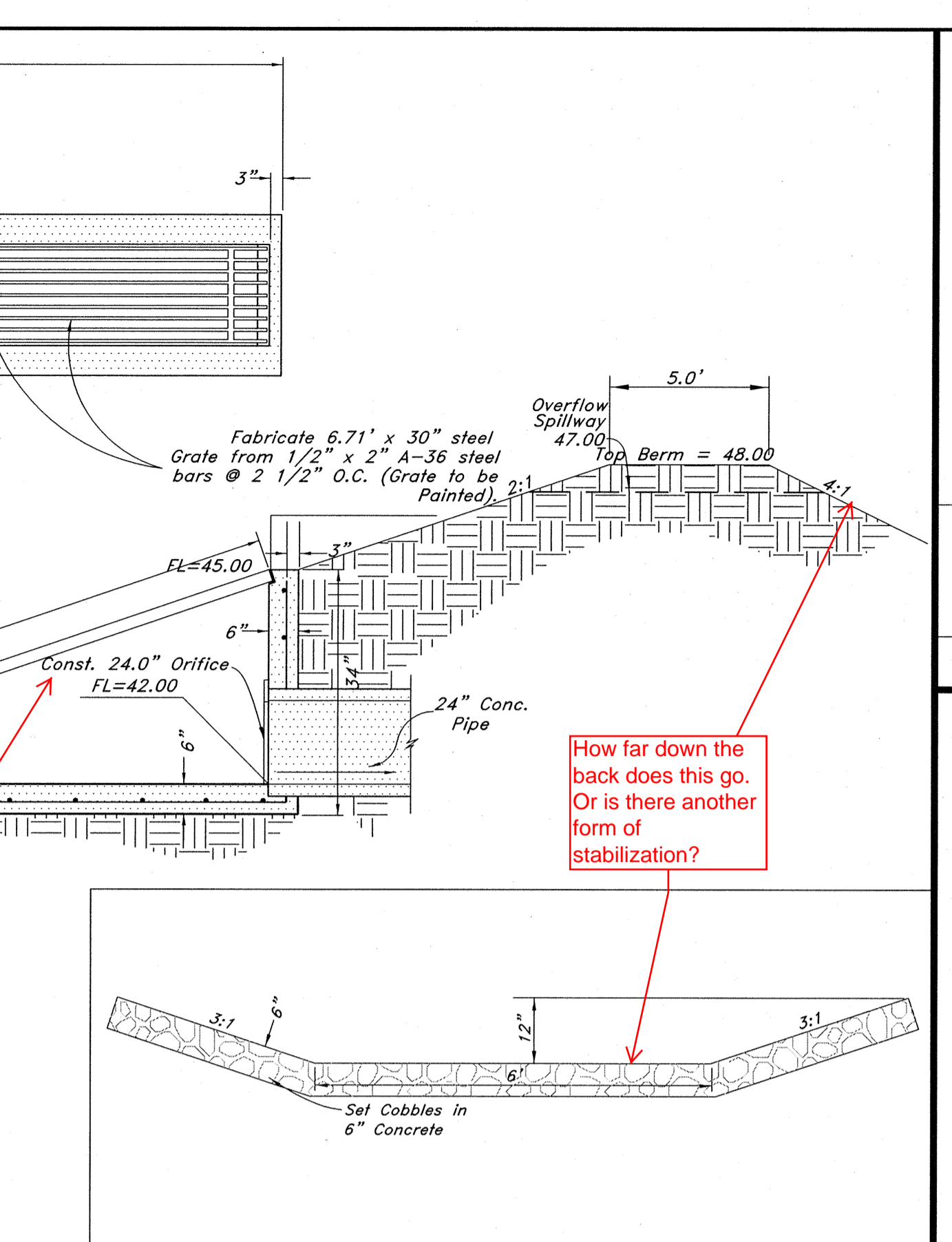

7 Emergency Overflow Spillway
Not to Scale

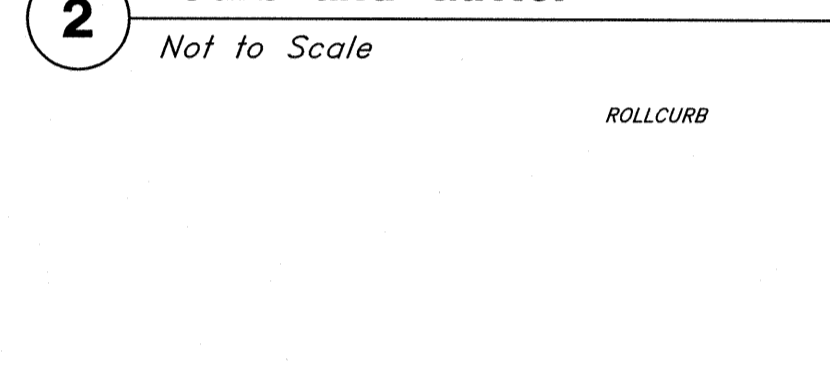

ROLLCURB

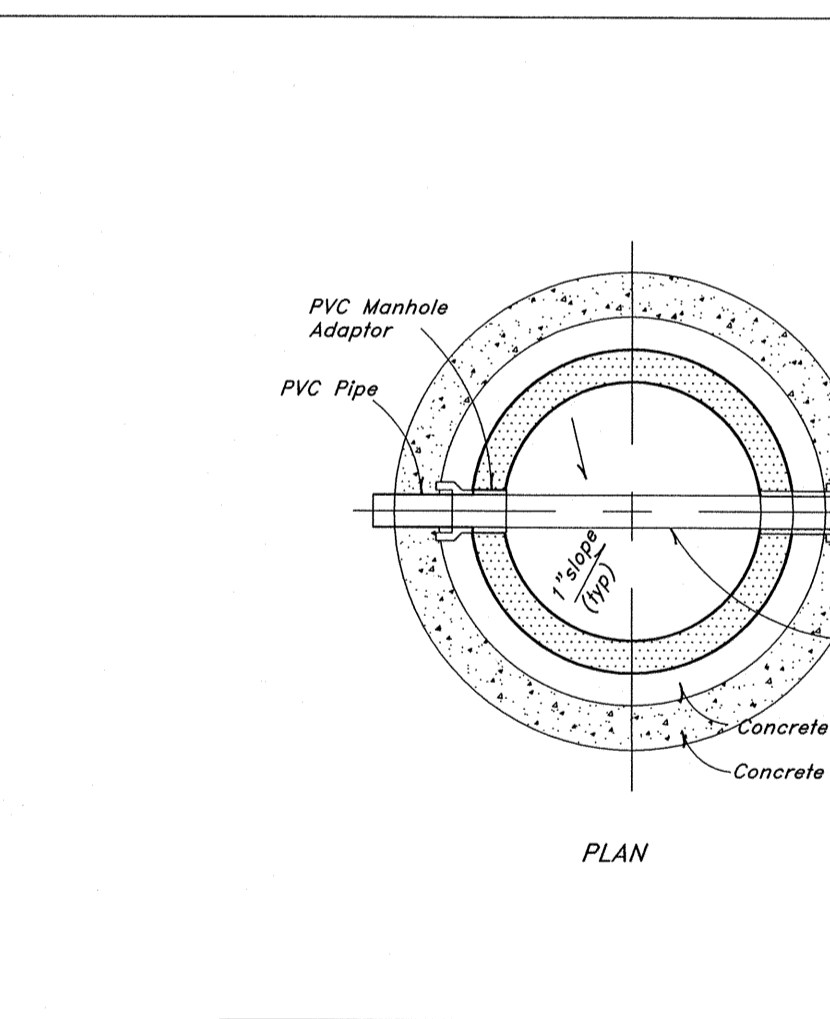

8 Typical 4.0' Manhole Detail
Not to Scale

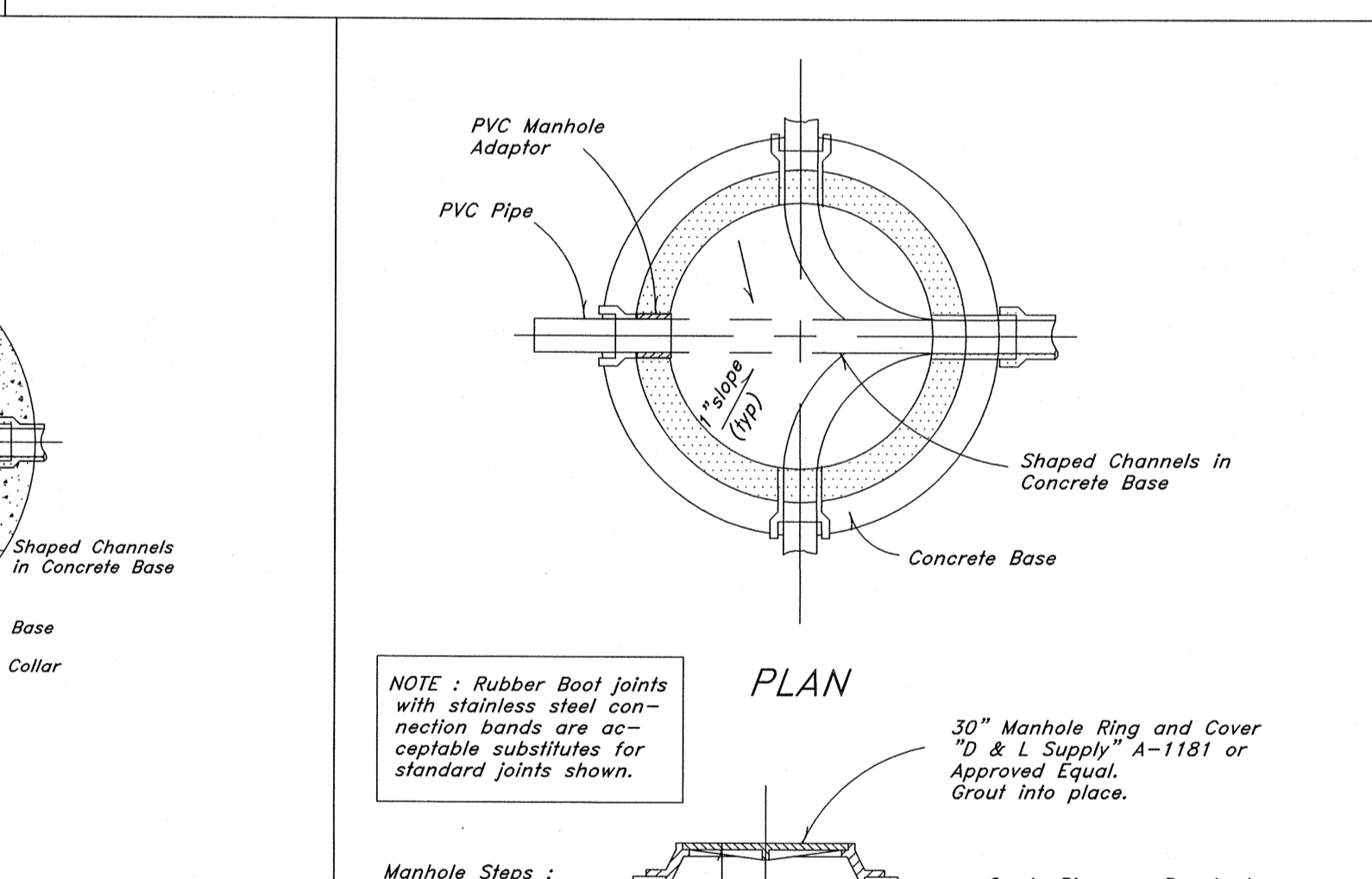

9 Typical 5.0' Manhole Detail
Not to Scale

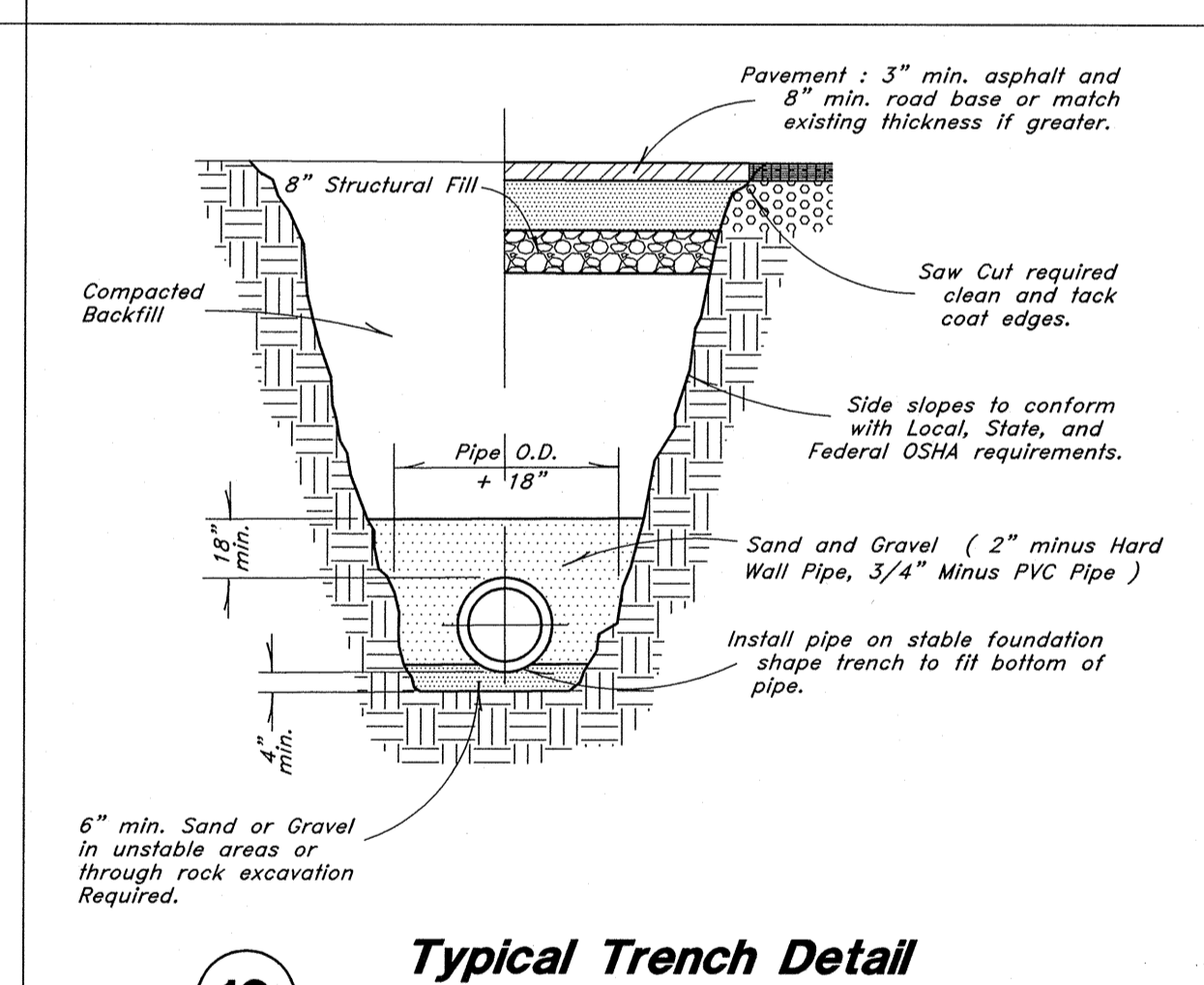

10 Typical Trench Detail
Not to Scale

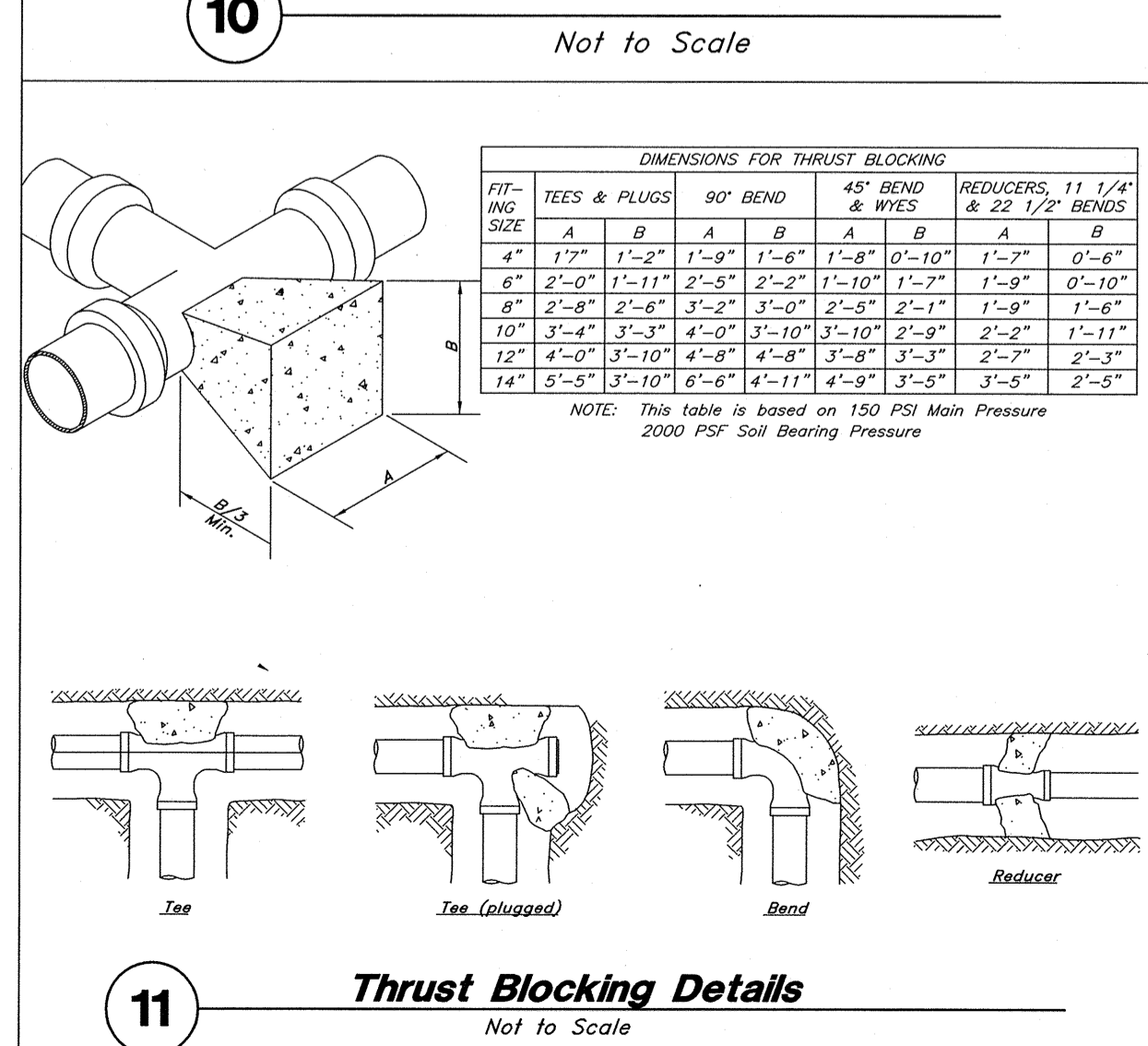

11 Thrust Blocking Details
Not to Scale

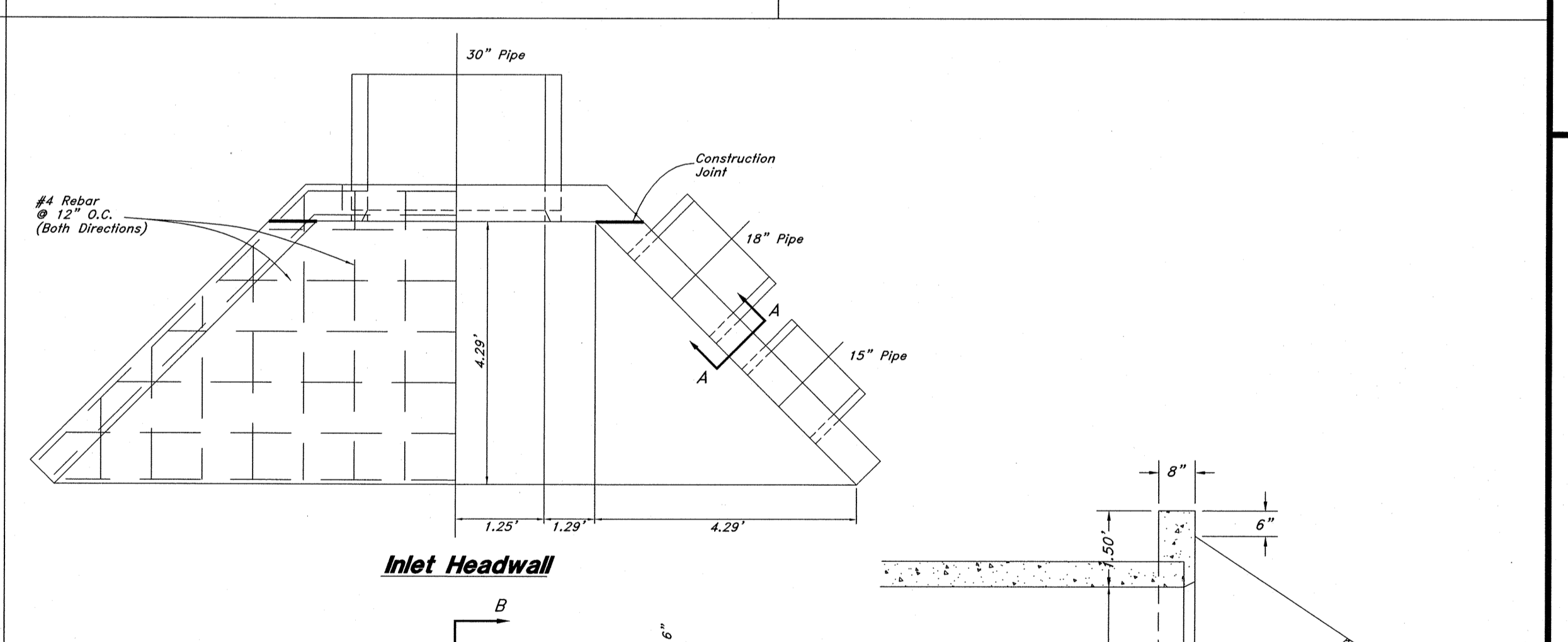

Inlet Headwall

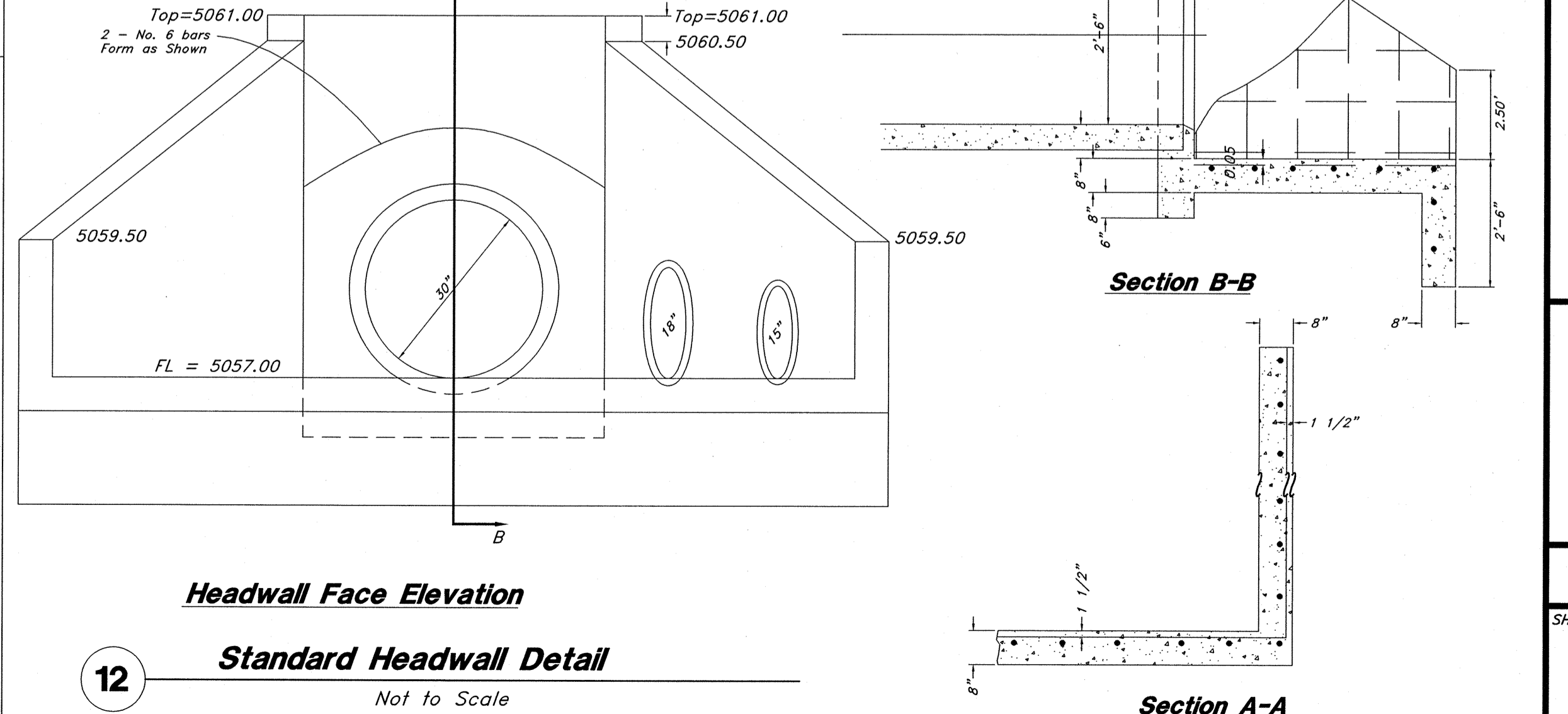

12 Standard Headwall Detail
Not to Scale

GREAT BASIN ENGINEERING
 5748 SOUTH 1475 EAST, OGDEN, UTAH 84403
 MAIN OFFICE: 402.231.8223 FAX: 402.231.8204
 WWW.GREATBASINENGINEERING.COM

The Chalets at Ski Lake No. 7
 A part of the Southwest 1/4 of Section 13, a part of the Northeast 1/4 of Section 24, 1/4 of Section 23, and a part of the Northwest 1/4 of Section 24, T6N, R1E, S18BM, U.S. Survey.

Details
 Jan, 2012
 SHEET NO. **4**
 96N120 Waterline