

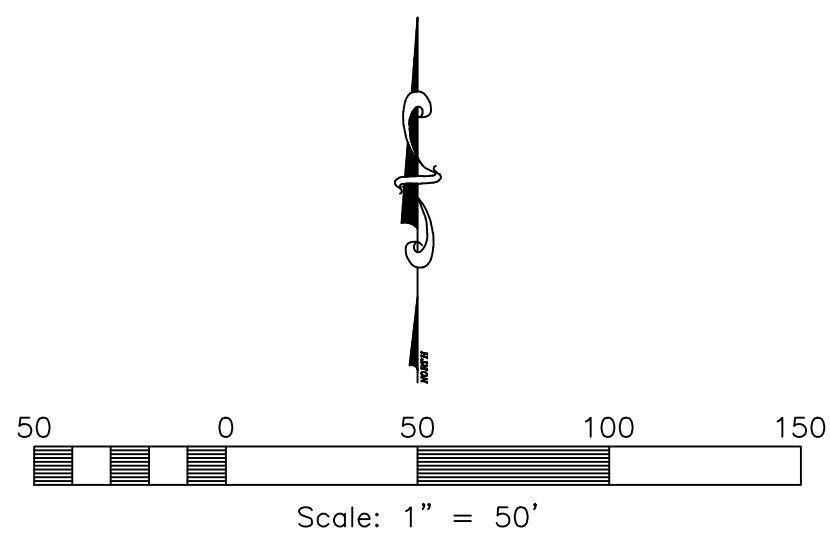

Vicinity Map

Design Criteria

| | |
|-------------------------------|------------------|
| Total Area..... | 12.67 ac. |
| Right-of-Way..... | 0.25 ac. |
| Developable Area..... | 12.42 ac. |
| Open Space..... | 3.82 ac. (30.2%) |
| Base Density..... | 13.53 lots |
| Bonus Density..... | 6.76 lots |
| Total Lots Proposed..... | 13 lots |
| Bonus Points Breakdown | |
| Cluster Development..... | 15.0% |
| Public Access..... | 15.0% |
| Excess Open Space..... | 14.8% |
| Bonus Proposed..... | 44.8% |



Boundary Description

A PART OF THE NE QUARTER OF SECTION 28, T.6N., R.2W., S.L.B.&M., U.S. SURVEY, DESCRIBED AS FOLLOWS:
 BEGINNING AT THE INTERSECTION OF THE WEST RIGHT OF WAY OF 3500 SOUTH STREET AND THE NORTH RIGHT OF WAY OF 2200 SOUTH STREET, A POINT WHICH LIES N00°46'46"E 33.10 FEET AND N89°23'09"W 33.00 FEET FROM THE EAST QUARTER CORNER OF SECTION 28, THENCE N89°13'14"W 990.39 FEET TO THE SE CORNER OF LOT 8, ALLEN ESTATES PHASE 1; THENCE N00°46'46"E 303.48 FEET TO THE SE CORNER OF ALLEN ESTATES PHASE 2, THEN ALONG SAID SUBDIVISION THE FOLLOWING FOUR (4) COURSES: (1)N32°28'59"E 72.51 FEET; (2)N57°56'50"E 300.14 FEET; (3)N70°50'18"E 302.53 FEET; (4)S89°13'43"E 413.87 FEET TO THE WEST RIGHT OF WAY LINE OF 3500 WEST STREET; THENCE S00°36'51"W 631.14 FEET TO THE POINT OF BEGINNING.
 HAVING AN AREA OF 551928.56 SQUARE FEET, 12.671 ACRES

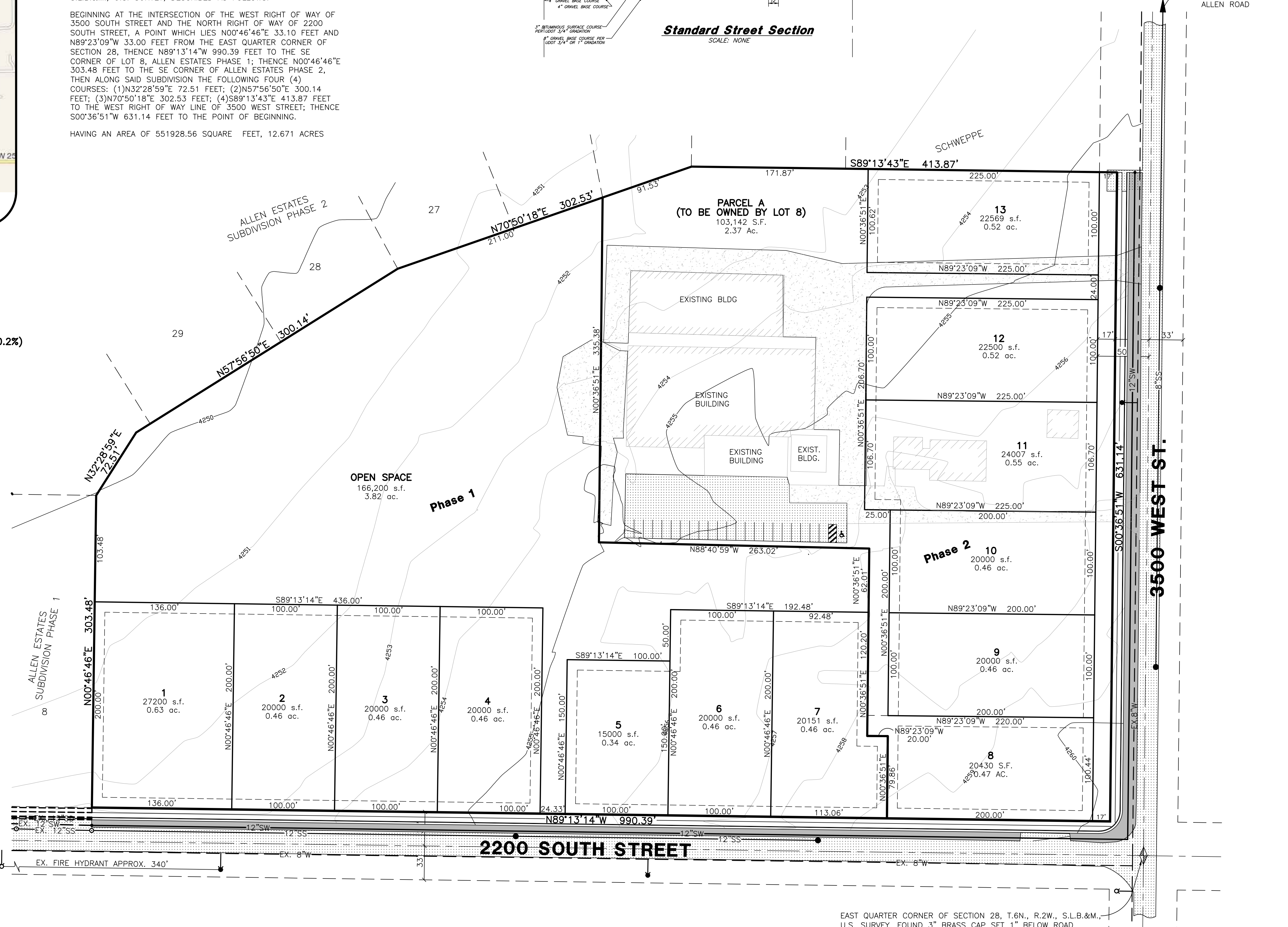
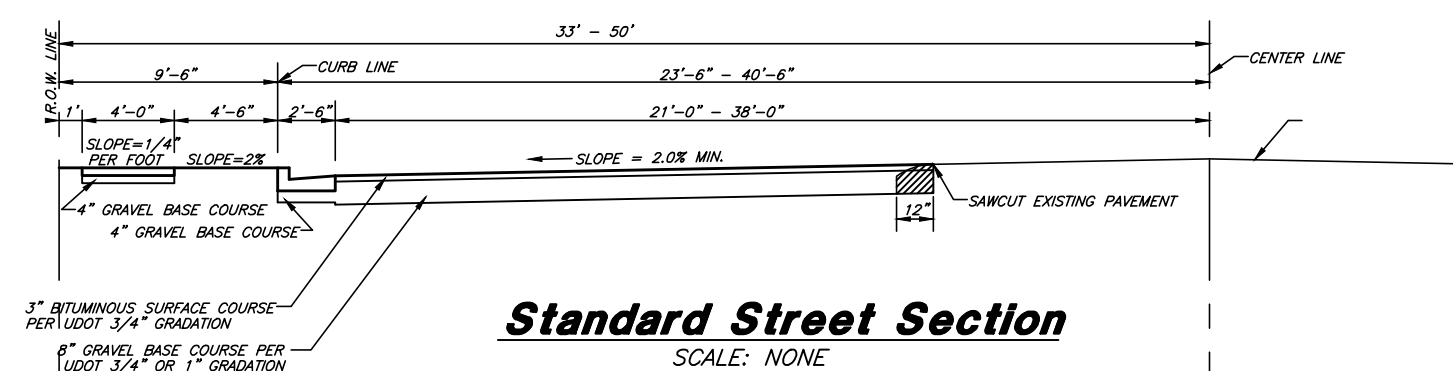

Legend

- SS— = PROPOSED SANITARY SEWER LINE
- EX SS— = EXISTING SANITARY SEWER LINE
- SW— = PROPOSED IRRIGATION WATER LINE
- EXIST SW— = EXISTING IRRIGATION WATER LINE (SIZE VARIES)
- W— = PROPOSED CULINARY WATER LINE (SIZE VARIES)
- EXIST W— = EXISTING CULINARY WATER LINE
- SD— = PROPOSED STORM DRAIN (SIZE VARIES)
- EXIST SD— = EXISTING STORM DRAIN
- X— = EXISTING FENCE LINE
- = PROPOSED FIRE HYDRANT
- = PROPOSED SANITARY SEWER MANHOLE
- = PROPOSED GATE VALVE
- = PLUG W/ 2" BLOW-OFF
- = PROPOSED STORM DRAIN MANHOLE
- = PROPOSED SINGLE GRATE CATCH BASIN WITH BICYCLE-SAFE GRATE
- = PROPOSED REDUCERS
- = PLUG & BLOCK
- = AIR-VAC ASSEMBLY
- ▨ = EXISTING ASPHALT SURFACE
- ▨ = PROPOSED ASPHALT SURFACE

NOTES:
 CONTOURS ARE SHOWN WITH A ONE FOOT INTERVAL.

Allen Horseplay Cluster Subdivision
 Weber County, Utah

EAST QUARTER CORNER OF SECTION 28, T.6N., R.2W., S.L.B.&M., U.S. SURVEY, FOUND 3" BRASS CAP SET 1" BELOW ROAD SURFACE (1963), GOOD CONDITION

Subdivider:
 Vaughn Allen
 2191 S. 3500 W.
 OGDEN, UT. 84401
 (801) 391-3880

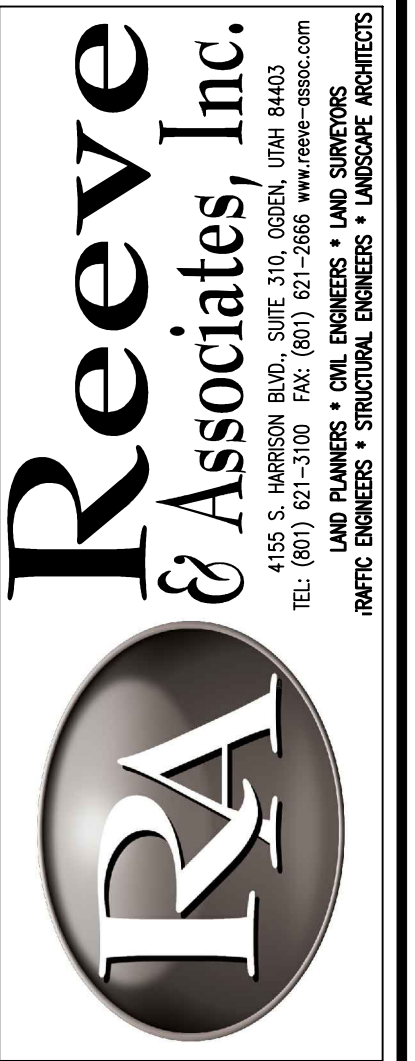

| REVISIONS | DESCRIPTION |
|-----------|-------------|
| | |
| | |
| | |
| | |
| | |
| | |
| | |
| | |
| | |
| | |

Allen Horseplay - Cluster Subdivision
 PART OF THE NE 1/4 OF SECTION 28, T.6N., R. 2W., S.L.B. & M., U.S. SURVEY
 WEBER COUNTY, UTAH

Preliminary Design

Preliminary
 INFORMATION CONTAINED HEREIN HAS NOT BEEN FINAL CHECKED. IT IS PROVIDED AT THIS TIME FOR PRELIMINARY REVIEW ONLY AND THE DATA SHOWN HEREON SHOULD NOT BE RELIED UPON FOR FINAL APPROVAL, DOCUMENTATION, DESIGN, AND/OR CONSTRUCTION.

Project Info.

| | |
|-------------|-------------------------------------|
| Engineer: | N. Reeve |
| Designer: | C. Cove |
| Begin Date: | MAY 3, 2010 |
| Name: | ALLEN HORSEPLAY CLUSTER SUBDIVISION |
| Number: | 5125-02 |