

Engineer's Notice To Contractors
 The existence and location of any underground utility pipes or structures shown on these plans were obtained from available information provided by others. The locations shown are approximate and shall be confirmed in the field by the contractor, so that any necessary adjustment can be made in alignment and/or grade of the proposed improvement. The contractor is required to contact the utility companies and take due precautionary measure to protect any utility lines shown, and any other lines obtained by the contractors research, and others not of record or not shown on these plans.

NOTICE!
 EXISTING UTILITIES ARE SHOWN ON PLANS FOR THE CONVENIENCE OF THE CONTRACTOR ONLY. THE CONTRACTOR IS RESPONSIBLE FOR THE PROTECTION OF ALL UTILITIES. THE ENGINEER BEARS NO RESPONSIBILITY FOR UTILITIES NOT SHOWN OR SHOWN INCORRECTLY.

Call Djs BEFORE YOU

1-800-662-4111
 UNDERGROUND SERVICE

LEGEND

- Subject Property Line
- - - Interior Lot Lines
- Adjoining Property Line
- - - Previous Property Line
- Centerline
- - - Public Utility Easement (PUE)
- - - Ditch
- - - Field Separation Line
- - - Fence Line (Wire)
- - - Fence Line (wood or Vinyl)
- Street Monument
- Found rebar set by others
- Set 5/8"x24" Rebar With Cap
- ◆ Section Corner

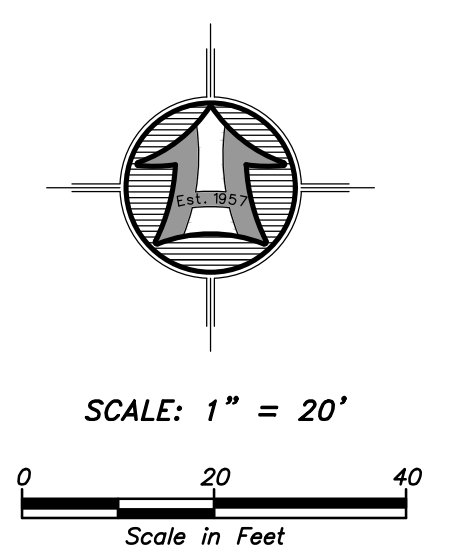

Layne & Joann Christensen
 22-071-0004

Jessica Berna
 22-022-0137

William & Lisa Rules
 22-071-0003

Conilyn P. Judge
 22-071-0002

Elizabeth M. & Bradley T Wilson
 22-022-0093

Site Plan for
Bill Rules
 4033 Nordic Valley Drive
 Liberty, UT

A Part of the Southwest Quarter of Section 28
 Township 7 North, Range 1 East, S.L.B.&M.

Drawn By: MTH Date: 10/23/17
 Designed By:
 Checked By:
 Approved By:
 Scale: 1" = 20'
 Drawing Title: 17-3-166/16
 JOB NUMBER: 17-3-166

HANSEN & ASSOCIATES, INC.
 Consulting Engineers and Land Surveyors
 538 North Main Street, Brigham, Utah 84302
 Visit us at www.haes.net
 Logan, Utah
 (435) 723-3491 (801) 399-4905 (435) 752-8272
 Celebrating 60 Years of Business

| No. | Date | By | Revision |
|-----|------|----|----------|
| | | | |
| | | | |
| | | | |

Sheet
1
 of
1
 Sheets