

SUNSET EQUESTRIAN Cluster Subdivision

WEBER COUNTY, UTAH

SHEET 3/SHEET 7

SHEET 6/SHEET 10

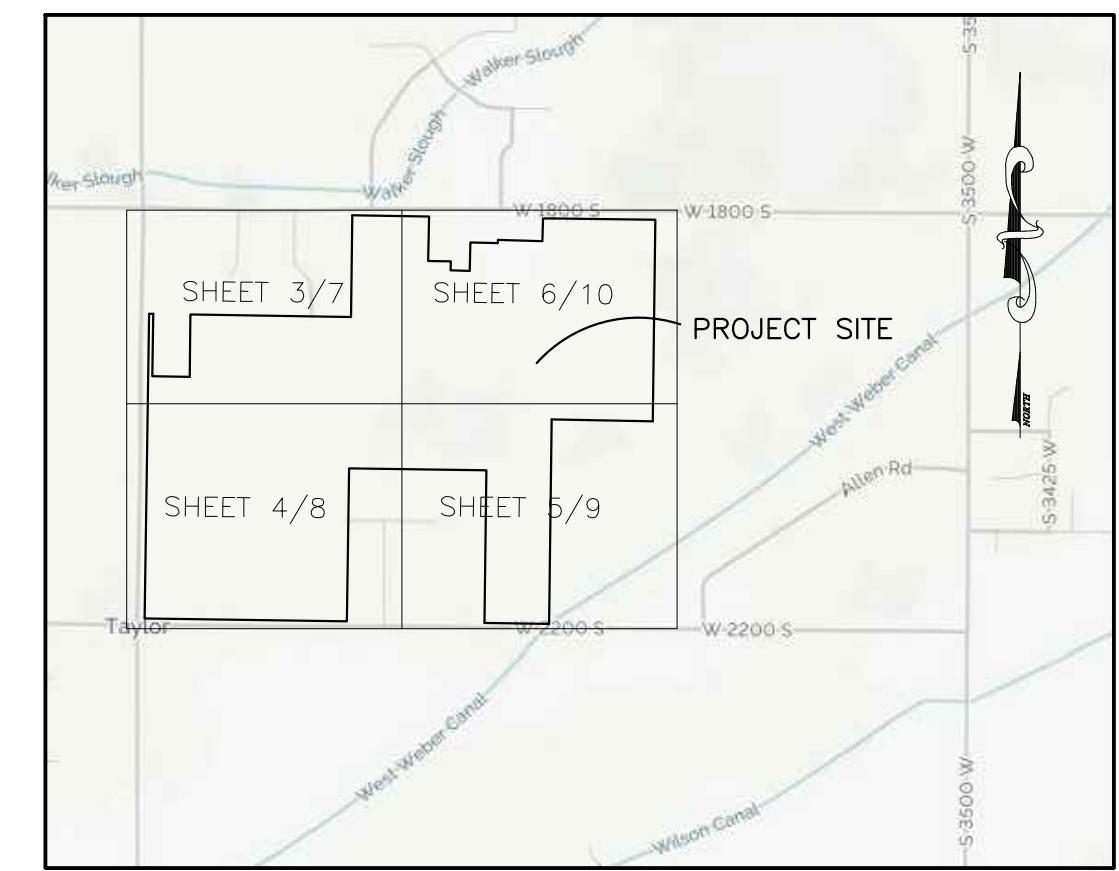

Vicinity Map
NOT TO SCALE

NORTH QUARTER CORNER OF SECTION 28, TOWNSHIP 6 NORTH, RANGE 2 WEST, SALT LAKE BASE & MERIDIAN, U.S. SURVEY, FOUND WEBER COUNTY SURVEY BRASS CAP MONUMENT DATED 1963, GOOD CONDITION

NORTHEAST CORNER OF SECTION 28, TOWNSHIP 6 NORTH, RANGE 2 WEST, SALT LAKE BASE & MERIDIAN, U.S. SURVEY, FOUND WEBER COUNTY SURVEY BRASS CAP MONUMENT DATED 1963, GOOD CONDITION

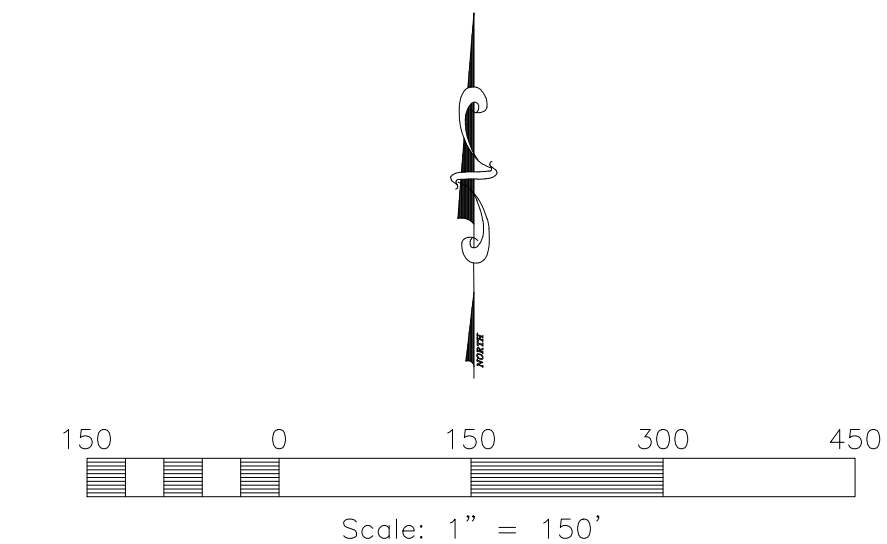

Sheet Index

- Sheet 1 - Cover/Index Sheet
- Sheet 2 - Notes/Legend/Street Cross-Section
- Sheet 3 - Preliminary Plan
- Sheet 4 - Preliminary Plan
- Sheet 5 - Preliminary Plan
- Sheet 6 - Preliminary Plan
- Sheet 7 - Preliminary Utilities Plan
- Sheet 8 - Preliminary Utilities Plan
- Sheet 9 - Preliminary Utilities Plan
- Sheet 10 - Preliminary Utilities Plan

Boundary Description

A PART OF THE NORTH HALF OF SECTION 28, TOWNSHIP 6 NORTH, RANGE 2 WEST DESCRIBED AS FOLLOWS:

BEGINNING AT A POINT ON THE NORTH SECTION LINE OF SAID SECTION 28, SAID POINT BEING N89°15'08"W 1982.76 FEET FROM NORTHEAST CORNER SAID SECTION 28; THENCE S00°40'05"W 1319.22 FEET; THENCE N88°58'51"W 661.97 FEET; THENCE S00°42'57"W 1338.28 FEET; THENCE N89°19'18"W 423.93 FEET; THENCE N00°46'46"E 1001.00 FEET; THENCE N89°13'14"W 900.33 FEET; THENCE S00°46'09"W 1001.00 FEET; THENCE N89°13'14"W 1324.08 FEET; THENCE N00°49'18"E 1994.38 FEET; THENCE S89°09'17"E 27.00 FEET; THENCE S00°49'10"W 407.99 FEET; THENCE S89°10'50"E 244.00 FEET; THENCE N00°49'10"E 407.88 FEET; THENCE S89°09'16"E 1051.19 FEET; THENCE N00°46'28"E 664.28 FEET; THENCE S89°07'58"E 502.24 FEET; THENCE S01°26'36"W 290.33 FEET; THENCE S88°33'24"E 150.00 FEET; THENCE S01°26'36"W 58.15 FEET; THENCE S88°33'24"E 125.00 FEET; THENCE N01°26'36"E 186.72 FEET; THENCE S88°33'24"E 180.00 FEET; THENCE N01°26'36"E 20.00 FEET; THENCE S88°33'24"E 290.00 FEET; THENCE N01°26'36"E 149.25 FEET; THENCE S89°07'58"E 74.34 FEET; THENCE S89°15'08"E 660.86 FEET TO THE POINT OF BEGINNING.

CONTAINING 5,862,085 SQUARE FEET OR 134.575 ACRES MORE OR LESS

Design Specs.

Total Area.....	134.58 ac.
Right-of-Way.....	20.71 ac.
Developable Area.....	113.87 ac.
Open Space.....	60.84 ac. (45.2%)
Base Density.....	124.00 lots
Bonus Density	
10% Purpose and Intent	
20% Street Trees and Lighting	
15% Public Access to Open Space	
20% Extra Open Space	
Total Lots Proposed.....	180 lots
Agriculture Parcels.....	40 parcels

Engineer's Notice To Contractors

THE EXISTENCE AND LOCATION OF ANY UNDERGROUND UTILITY PIPES OR STRUCTURES SHOWN ON THESE PLANS WERE OBTAINED FROM AVAILABLE INFORMATION PROVIDED BY OTHERS. THE LOCATIONS SHOWN ARE APPROXIMATE AND SHALL BE CONFIRMED IN THE FIELD BY THE CONTRACTOR, SO THAT ANY NECESSARY ADJUSTMENT CAN BE MADE IN ALIGNMENT AND/OR GRADE OF THE PROPOSED IMPROVEMENT. THE CONTRACTOR IS REQUIRED TO CONTACT THE UTILITY COMPANIES AND TAKE DUE PRECAUTIONARY MEASURE TO PROTECT ANY UTILITY LINES SHOWN, AND ANY OTHER LINES OBTAINED BY THE CONTRACTOR'S RESEARCH, AND OTHERS NOT OF RECORD OR NOT SHOWN ON THESE PLANS.

Developer Contact:

Fieldbrook Properties, Inc.
Chris Hoertel/Doug Nosler
Irvine, CA 92618
PH: (949) 453-9279

Blue Stakes Location Center

Call: Toll Free
1-800-662-4111
Two Working Days Before You Dig

Revised: 10-2-17

Project Info.

Engineer: N. REEVE
Drafted: E. ROCHE
Begin Date: 6-15-17
Name: SUNSET EQUESTRIAN CLUSTER SUBDIVISION
Number: 5336-05

Sheet **10**
1 Sheets

Reeve & Associates, Inc.
5160 SOUTH 1500 WEST RIVERDALE, UTAH 84405
TEL: (801) 921-2100 FAX: (801) 921-2666 WWW: REEVE-ASSOCIATES.COM
LAND PLANNERS • CIVIL ENGINEERS • LAND SURVEYORS
TRAFFIC ENGINEERS • STRUCTURAL ENGINEERS • LANDSCAPE ARCHITECTS

REVISIONS	DATE	DESCRIPTION
	07/21/17	JM Preim Completed
	06/23/17	ER City Redlines
	10/2/17	ER Cluster Revised

Sunset Equestrian Cluster Subdivision
WEBER COUNTY, UTAH
Cover/Index Sheet

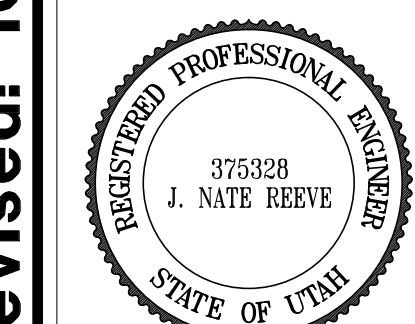

1/4/2016 | E:\3336\05\Preliminary\Preliminary 09-28-17.dwg | Reeve & Associates, Inc. - Solutions You Can Build On

General Notes:

- ALL CONSTRUCTION MUST STRICTLY FOLLOW THE STANDARDS AND SPECIFICATIONS SET FORTH BY: GOVERNING UTILITY MUNICIPALITY, GOVERNING CITY OR COUNTY (IF UNINCORPORATED), INDIVIDUAL PRODUCT MANUFACTURERS, AMERICAN PUBLIC WORKS ASSOCIATION (APWA), AND THE DESIGN ENGINEER. THE ORDER LISTED ABOVE IS ARRANGED BY SENIORITY. IF A CONSTRUCTION PRACTICE IS NOT SPECIFIED BY ANY OF THE LISTED SOURCES, CONTRACTOR MUST CONTACT DESIGN ENGINEER FOR DIRECTION.
- CONTRACTOR TO STRICTLY FOLLOW GEOTECHNICAL RECOMMENDATIONS FOR THIS PROJECT, ALL GRADING INCLUDING BUT NOT LIMITED TO CUT, FILL, CONCRETION, ASPHALT SECTION, SUBBASE, TRENCH, EXCAVATION/BACKFILL, SITE GRUBBING, RETAINING WALLS AND FOOTINGS MUST BE COORDINATED DIRECTLY WITH THE PROJECT GEOTECHNICAL ENGINEER.
- TRAFFIC CONTROL, STRIPING & SIGNAGE TO CONFORM TO CURRENT GOVERNING AGENCIES TRANSPORTATION ENGINEER'S MANUAL AND MANUAL OF UNIFORM TRAFFIC CONTROL DEVICES.
- ANY AREA OUTSIDE THE LIMIT OF WORK THAT IS DISTURBED SHALL BE RESTORED TO ITS ORIGINAL CONDITION AT NO COST TO OWNER.
- CONSULT ALL OF THE DRAWINGS AND SPECIFICATIONS FOR COORDINATION REQUIREMENTS BEFORE COMMENCING CONSTRUCTION.
- AT ALL LOCATIONS WHERE EXISTING PAVEMENT ABUTS NEW CONSTRUCTION, THE EDGE OF THE EXISTING PAVEMENT SHALL BE SAWCUT TO A CLEAN, SMOOTH EDGE.
- ALL CONSTRUCTION AND MATERIALS SHALL BE IN ACCORDANCE WITH THE MOST RECENT, ADOPTED EDITION OF ADA ACCESSIBILITY GUIDELINES.
- PRIOR TO STARTING CONSTRUCTION, THE CONTRACTOR SHALL BE RESPONSIBLE FOR MAKING SURE THAT ALL REQUIRED PERMITS AND APPROVALS HAVE BEEN OBTAINED. NO CONSTRUCTION OR FABRICATION SHALL BEGIN UNTIL THE CONTRACTOR HAS RECEIVED THOROUGHLY REVIEWED PLANS AND OTHER DOCUMENTS APPROVED BY ALL OF THE PERMITTING AUTHORITIES.
- CONTRACTOR IS RESPONSIBLE FOR SCHEDULING AND NOTIFYING ENGINEER OR INSPECTING AUTHORITY 48 HOURS IN ADVANCE OF COVERING UP ANY PHASE OF CONSTRUCTION REQUIRING OBSERVATION.
- ANY WORK IN THE PUBLIC RIGHT OF WAY WILL REQUIRE PERMITS FROM THE APPROPRIATE CITY, COUNTY OR STATE AGENCY CONTROLLING THE ROAD, INCLUDING OBTAINING REQUIRED INSPECTIONS.
- ALL DIMENSIONS, GRADES & UTILITY DESIGNS SHOWN ON THE PLANS SHALL BE VERIFIED BY THE CONTRACTOR PRIOR TO CONSTRUCTION. CONTRACTOR SHALL NOTIFY ENGINEER OF ANY DISCREPANCIES PRIOR TO PROCEEDING WITH CONSTRUCTION FOR NECESSARY PLAN OR GRADE CHANGES.
- CONTRACTOR MUST VERIFY ALL EXISTING CONDITIONS BEFORE BIDDING AND BRING UP ANY QUESTIONS BEFOREHAND.
- SITE GRADING SHALL BE PERFORMED IN ACCORDANCE WITH THESE PLANS AND SPECIFICATIONS AND THE RECOMMENDATIONS SET FORTH BY THE GEOTECHNICAL ENGINEER.
- CATCH SLOPES SHALL BE GRADED AS SPECIFIED ON GRADING PLANS.
- CONTRACTOR SHALL BE RESPONSIBLE FOR ALL FLAGGING, CAUTION SIGNS, LIGHTS, BARRICADES, FLAGMEN, AND ALL OTHER DEVICES NECESSARY FOR PUBLIC SAFETY.
- CONTRACTOR SHALL, AT THE TIME OF BIDDING AND THROUGHOUT THE PERIOD OF THE CONTRACT, BE LICENSED IN THE STATE WHERE THE PROJECT IS LOCATED AND SHALL BE BONDABLE FOR AN AMOUNT EQUAL TO OR GREATER THAN THE AMOUNT BID AND TO DO THE TYPE OF WORK CONTEMPLATED IN THE PLANS AND SPECIFICATIONS. CONTRACTOR SHALL BE SKILLED AND REGULARLY ENGAGED IN THE GENERAL CLASS AND TYPE OF WORK CALLED FOR IN THE PLANS AND SPECIFICATIONS.
- CONTRACTOR SHALL INSPECT THE SITE OF THE WORK PRIOR TO BIDDING TO SATISFY HIMSELF BY PERSONAL EXAMINATION OR BY SUCH OTHER MEANS AS HE MAY PREFER OF THE LOCATIONS OF THE PROPOSED WORK AND OF THE ACTUAL CONDITIONS OF AND AT THE SITE OF WORK. IF DURING THE COURSE OF HIS EXAMINATION, A BIDDER FINDS FACTS OR CONDITIONS WHICH APPEAR TO HIM TO BE IN CONFLICT WITH THE LETTER OR SPIRIT OF THE PROJECT PLANS AND SPECIFICATIONS, HE SHALL CONTACT THE ENGINEER FOR ADDITIONAL INFORMATION AND EXPLANATION BEFORE SUBMITTING HIS BID. SUBMISSION OF A BID BY THE CONTRACTOR SHALL CONSTITUTE ACKNOWLEDGMENT THAT, IF AWARDED THE CONTRACT, HE HAS RELIED AND IS RELYING ON HIS OWN EXAMINATION OF (1) THE SITE OF THE WORK, (2) ACCESS TO THE SITE, AND (3) ALL OTHER DATA AND MATTERS REQUISITE TO THE FULFILLMENT OF THE WORK AND ON HIS OWN KNOWLEDGE OF EXISTING FACILITIES ON AND IN THE VICINITY OF THE SITE OF THE WORK TO BE CONSTRUCTED UNDER THIS CONTRACT. THE INFORMATION PROVIDED BY THE ENGINEER IS NOT INTENDED TO BE A SUBSTITUTE FOR, OR A SUPPLEMENT TO, THE INDEPENDENT VERIFICATION BY THE CONTRACTOR TO THE EXTENT SUCH INDEPENDENT INVESTIGATION OF SITE CONDITIONS IS DEEMED NECESSARY OR DESIRABLE BY THE CONTRACTOR. CONTRACTOR SHALL ACKNOWLEDGE THAT HE HAS NOT RELIED SOLELY UPON OWNER- OR ENGINEER-FURNISHED INFORMATION REGARDING SITE CONDITIONS IN PREPARING AND SUBMITTING HIS BID.
- CONTRACTOR SHALL BE RESPONSIBLE TO PROVIDE ALL WATER, POWER, SANITARY FACILITIES AND TELEPHONE SERVICES AS REQUIRED FOR THE CONTRACTOR'S USE DURING CONSTRUCTION.
- CONTRACTOR SHALL BE HELD RESPONSIBLE FOR ANY FIELD CHANGES MADE WITHOUT PRIOR WRITTEN AUTHORIZATION FROM THE OWNER, ENGINEER, AND/OR GOVERNING AGENCIES.
- CONTRACTOR SHALL EXERCISE DUE CAUTION AND SHALL CAREFULLY PRESERVE BENCH MARKS, CONTROL POINTS, REFERENCE POINTS AND ALL SURVEY STAKES, AND SHALL BEAR ALL EXPENSES FOR REPLACEMENT AND/OR ERRORS CAUSED BY THEIR UNNECESSARY LOSS OR DISTURBANCE.
- CONTRACTOR SHALL ASSUME SOLE AND COMPLETE RESPONSIBILITY FOR JOBSITE CONDITIONS DURING THE COURSE OF CONSTRUCTION OF THIS PROJECT, INCLUDING SAFETY OF ALL PERSONS AND PROPERTY. THIS REQUIREMENT SHALL APPLY CONTINUOUSLY AND NOT BE LIMITED TO NORMAL WORKING HOURS. THE CONTRACTOR SHALL DEFEND, INDEMNIFY AND HOLD THE OWNER AND ENGINEER HARMLESS FROM ANY AND ALL LIABILITY, REAL OR ALLEGED, IN CONNECTION WITH THE PERFORMANCE OF WORK ON THIS PROJECT, EXCEPTING FOR LIABILITY ARISING FROM THE SOLE NEGLIGENCE OF THE OWNER OR THE ENGINEER.
- CONTRACTOR SHALL BE RESPONSIBLE FOR ADEQUATELY SCHEDULING INSPECTION AND TESTING OF ALL FACILITIES CONSTRUCTED UNDER THIS CONTRACT. ALL TESTING SHALL CONFORM TO THE REGULATORY AGENCY'S STANDARD SPECIFICATIONS. ALL TESTING AND INSPECTION SHALL BE PAID FOR BY THE OWNER; ALL RE-TESTING AND/OR RE-INSPECTION SHALL BE PAID FOR BY THE CONTRACTOR.
- IF EXISTING IMPROVEMENTS NEED TO BE DISTURBED AND/OR REMOVED FOR THE PROPER PLACEMENT OF IMPROVEMENTS TO BE CONSTRUCTED BY THESE PLANS, THE CONTRACTOR SHALL BE RESPONSIBLE FOR PROTECTING EXISTING IMPROVEMENTS. THE COST OF REPLACING OR REPAIRING EXISTING IMPROVEMENTS SHALL BE INCLUDED IN THE UNIT PRICE BID FOR ITEMS REQUIRING REMOVAL AND/OR REPLACEMENT. THERE WILL BE NO EXTRA COST DUE TO THE CONTRACTOR FOR REPLACING OR REPAIRING EXISTING IMPROVEMENTS.
- WHENEVER EXISTING FACILITIES ARE REMOVED, DAMAGED, BROKEN, OR CUT IN THE INSTALLATION OF THE WORK COVERED BY THESE PLANS OR SPECIFICATIONS, SAID FACILITIES SHALL BE REPLACED AT THE CONTRACTOR'S EXPENSE WITH MATERIALS EQUAL TO OR BETTER THAN THE MATERIALS USED IN THE ORIGINAL EXISTING FACILITIES. THE FINISHED PRODUCT SHALL BE SUBJECT TO THE APPROVAL OF THE OWNER, THE ENGINEER, AND THE RESPECTIVE REGULATORY AGENCY.
- CONTRACTOR SHALL MAINTAIN A NEATLY MARKED SET OF FULL-SIZE AS-BUILT RECORD DRAWINGS SHOWING THE FINAL LOCATION AND LAYOUT OF ALL STRUCTURES AND OTHER FACILITIES, AS-BUILT RECORD DRAWINGS SHALL REFLECT CHANGE ORDERS, ACCOMMODATIONS, AND ADJUSTMENTS TO ALL IMPROVEMENTS CONSTRUCTED, WHERE NECESSARY. SUPPLEMENTAL DRAWINGS SHALL BE PREPARED AND SUBMITTED BY THE CONTRACTOR, PRIOR TO ACCEPTANCE OF THE PROJECT, THE CONTRACTOR SHALL DELIVER TO THE ENGINEER ONE SET OF NEATLY MARKED AS-BUILT RECORD DRAWINGS SHOWING THE INFORMATION REQUIRED ABOVE. AS-BUILT RECORD DRAWINGS SHALL BE REVIEWED AND THE COMPLETE AS-BUILT RECORD DRAWING SET SHALL BE CURRENT WITH ALL CHANGES AND DEVIATIONS REDLINED AS A PRECONDITION TO THE FINAL PROGRESS PAYMENT APPROVAL AND/OR FINAL ACCEPTANCE.
- WHERE THE PLANS OR SPECIFICATIONS DESCRIBE PORTIONS OF THE WORK IN GENERAL TERMS BUT NOT IN COMPLETE DETAIL, IT IS UNDERSTOOD THAT ONLY THE BEST GENERAL PRACTICE IS TO PREVAIL AND THAT ONLY MATERIALS AND WORKMANSHIP OF THE HIGHEST QUALITY ARE TO BE USED.
- CONTRACTOR SHALL BE SKILLED AND REGULARLY ENGAGED IN THE GENERAL CLASS AND TYPE OF WORK CALLED FOR IN THE PROJECT PLANS AND SPECIFICATIONS. THEREFORE, THE OWNER IS RELYING UPON THE EXPERIENCE AND EXPERTISE OF THE CONTRACTOR. PRICES PROVIDED WITHIN THE CONTRACT DOCUMENTS SHALL INCLUDE ALL LABOR AND MATERIALS NECESSARY AND PROPER FOR THE WORK CONTEMPLATED AND THAT THE WORK BE COMPLETED IN ACCORDANCE WITH THE TRUE INTENT AND PURPOSE OF THESE PLANS AND SPECIFICATIONS. THE CONTRACTOR SHALL BE COMPETENT, KNOWLEDGEABLE AND HAVE SPECIAL SKILLS IN THE NATURE, EXTENT AND INHERENT CONDITIONS OF THE WORK TO BE PERFORMED. CONTRACTOR SHALL ALSO ACKNOWLEDGE THAT THERE ARE CERTAIN PECULIAR AND INHERENT CONDITIONS EXISTENT IN THE CONSTRUCTION OF THE PARTICULAR FACILITIES WHICH MAY CREATE, DURING THE CONSTRUCTION PROGRAM, UNUSUAL OR UNSAFE CONDITIONS HAZARDOUS TO PERSONS, PROPERTY AND THE ENVIRONMENT. CONTRACTOR SHALL BE AWARE OF SUCH PECULIAR RISKS AND HAVE THE SKILL AND EXPERIENCE TO FORESEE AND TO ADOPT PROTECTIVE MEASURES TO ADEQUATELY AND SAFELY PERFORM THE CONSTRUCTION WORK WITH RESPECT TO SUCH HAZARDS.
- CONTRACTOR SHALL BE RESPONSIBLE FOR THE REMOVAL OF ALL STRIPING AND/OR PAVEMENT MARKINGS NECESSARY TO THE EXISTING STRIPING INTO FUTURE STRIPING. METHOD OF REMOVAL SHALL BE BY WATER BLASTING.
- CONTRACTOR SHALL PROVIDE ALL SHORING, BRACING, SLOPING OR OTHER PROVISIONS NECESSARY TO PROTECT WORKMEN FOR ALL AREAS TO BE EXCAVATED TO A DEPTH OF 4 FEET OR MORE. FOR EXCAVATIONS 4 FEET OR MORE IN DEPTH, THE CONTRACTOR SHALL COMPLY WITH LOCAL, STATE, AND NATIONAL SAFETY CODES, ORDINANCES, OR REQUIREMENTS FOR EXCAVATION AND TRENCHES.
- ALL EXISTING GATES AND FENCES TO REMAIN UNLESS OTHERWISE NOTED ON PLANS. PROTECT ALL GATES AND FENCES FROM DAMAGE

Curve Table

#	RADIUS	ARC LENGTH	CHD LENGTH	TANGENT	CHD BEARING	DELTA
C1	30.00'	17.09'	16.86'	8.78'	N15°29'46"W	32°38'13"
C2	65.00'	74.85'	70.79'	42.20'	S01°10'36"W	65°58'58"
C3	65.00'	79.21'	74.40'	45.37'	S69°04'48"W	69°49'27"
C4	65.00'	22.08'	21.98'	11.15'	N66°16'28"W	19°28'01"
C5	30.00'	17.09'	16.86'	8.78'	N72°51'54"W	32°38'13"
C6	20.00'	31.42'	28.28'	20.00'	N49°49'20"E	90°00'00"
C7	267.00'	67.73'	67.55'	34.05'	N06°26'41"E	14°32'02"
C8	267.00'	20.89'	20.89'	10.45'	S15°57'13"E	4°29'01"
C9	267.00'	118.06'	117.10'	60.01'	S30°51'44"E	25°20'02"
C10	333.00'	7.41'	7.41'	3.70'	N42°53'31"W	1°16'29"
C11	333.00'	250.62'	244.75'	131.58'	S20°41'37"E	43°07'18"
C12	300.00'	232.46'	226.69'	122.42'	S21°19'52"E	44°23'48"
C13	267.00'	55.10'	55.00'	27.65'	N05°02'42"W	11°49'28"
C14	267.00'	127.22'	126.02'	64.84'	S24°36'25"E	27°17'58"
C15	267.00'	24.57'	24.56'	12.29'	S40°53'35"E	5°16'22"
C16	333.00'	83.40'	83.18'	41.92'	N36°21'17"W	14°20'58"
C17	333.00'	101.37'	100.98'	51.08'	N20°27'32"W	17°26'32"
C18	333.00'	20.00'	20.00'	10.00'	N10°01'01"W	3°26'30"
C19	333.00'	52.99'	52.94'	26.55'	N03°44'13"W	9°07'06"
C20	300.00'	232.22'	226.47'	122.28'	S21°21'13"E	44°21'06"
C21	30.00'	17.09'	16.86'	8.78'	N74°30'14"E	32°38'13"
C22	65.00'	4.02'	4.01'	2.01'	N59°57'18"E	3°32'21"
C23	65.00'	172.14'	126.07'	258.15'	N42°24'30"W	151°44'05"
C24	30.00'	17.09'	16.86'	8.78'	S17°08'26"W	32°38'13"
C25	20.00'	31.42'	28.28'	20.00'	N44°10'40"W	90°00'00"
C26	267.00'	103.84'	103.19'	52.58'	N11°57'50"E	27°16'59"
C27	333.00'	37.39'	37.37'	18.71'	N19°53'20"E	6°25'58"
C28	333.00'	92.12'	91.83'	46.36'	N08°44'51"E	15°51'01"
C29	275.00'	25.96'	25.95'	12.99'	N86°30'57"W	5°24'34"
C30	275.00'	45.06'	45.01'	22.58'	S79°07'03"E	9°23'16"
C31	55.00'	3.09'	3.09'	1.54'	N76°01'56"W	3°13'02"
C32	55.00'	61.50'	58.34'	34.41'	N70°19'39"E	64°03'49"
C33	55.00'	57.56'	54.97'	31.73'	N08°18'53"E	59°57'44"
C34	55.00'	57.56'	54.97'	31.73'	N51°38'51"W	59°57'44"
C35	55.00'	63.06'	59.66'	35.51'	S65°31'35"W	65°41'25"
C36	30.00'	38.11'	38.65'	22.16'	S69°10'44"E	72°54'43"
C37	325.00'	35.99'	35.97'	18.01'	N77°35'45"W	6°20'41"
C38	325.00'	47.94'	47.90'	24.02'	N84°59'40"W	8°27'08"
C39	300.00'	77.48'	77.26'	38.96'	S81°49'19"E	14°47'49"
C40	267.00'	35.13'	35.10'	17.59'	S04°35'29"W	7°32'17"
C41	267.00'	68.71'	68.52'	34.55'	S15°43'58"W	14°44'42"
C42	300.00'	116.67'	115.94'	59.08'	N11°57'50"E	22°16'59"
C43	333.00'	47.17'	47.13'	23.62'	N19°02'52"E	8°06'55"
C44	333.00'	82.34'	82.13'	41.38'	S07°54'22"W	14°10'04"
C45	300.00'	116.67'	115.94'	59.08'	S11°57'50"W	22°16'59"
C46	332.00'	38.11'	38.45'	16.79'	S03°58'50"E	6°44'51"
C47	332.00'	75.19'	75.03'	37.76'	N12°58'46"W	12°58'35"
C48	332.00'	77.99'	77.82'	39.18'	N26°11'51"E	13°27'37"
C49	332.00'	78.00'	77.82'	39.18'	N39°39'30"E	13°27'40"
C50	332.00'	77.99'	77.81'	39.18'	N53°07'07"E	13°27'35"
C53	332.00'	26.72'	26.71'	13.37'	N62°09'14"E	4°36'39"
C54	299.00'	332.65'	315.76'	185.91'	N32°35'15"E	63°44'37"
C55	299.00'	291.23'	279.85'	158.34'	N28°37'09"E	55°48'25"
C56	299.00'	41.42'	41.38'	20.74'	N60°29'28"E	7°56'12"
C57	266.00'	238.01'	230.15'	127.64'	N26°20'57"E	51°16'00"
C58	175.00'	86.34'	85.94'	43.57'	S51°17'41"E	21°14'10"
C59	175.00'	83.11'	82.23'	42.30'	N75°44'35"W	27°10'39"
C60	150.00'	127.99'	124.14'	68.18'	S64°53'16"E	48°53'18"
C61	125.00'	106.68'	103.47'	56.83'	S64°53'01"E	48°53'49"
C62	225.00'	16.68'	16.67'	8.34'	S87°12'30"E	4°14'49"
C63	225.00'	77.49'	77.10'	39.13'	N75°13'09"W	19°43'53"
C64	275.00'	47.22'	47.16'	23.67'	N70°16'21"W	9°50'18"
C65	275.00'	67.41'	67.24'	33.88'	N82°12'51"W	14°02'42"
C66	250.00'	104.21'	103.46'	52.87'	S77°17'42"E	23°53'00"
C67	225.00'	48.24'	48.14'	24.21'	N83°05'42"W	12°17'00"
C68	225.00'	45.55'	45.48'	22.85'	S71°09'12"E	11°36'00"
C69	275.00'	49.74'	49.62'	29.99'	N71°36'16"W	12°26'48"
C70	275.00'	55.35'	55.26'	27.77'	N83°33'58"W	11°31'55"
C71	250.00'	104.63'	103.86'	53.09'	S77°20'34"E	23°58'43"
C72	483.00'	261.33'	258.15'	133.95'	N49°50'21"E	31°00'00"
C73	483.00'	80.07'	79.98'	40.13'	N29°35'25"E	9°29'53"
C74	483.00'	80.07'	79.98'	40.13'	N20°05'32"E	9°29'53"
C75	483.00'	80.21'	80.12'	40.20'	S10°35'08"W	9°30'54"
C76	483.00'	43.32'	43.30'	21.67'	S03°15'32"W	5°08'19"
C77	450.00'	500.85'	475.39'	279.93'	N32°34'28"E	63°46'11"
C78	450.00'	419.78'	404.72'	226.56'	N37°44'08"E	53°26'51"
C79	450.00'	81.07'	80.96'	40.64'	S05°51'03"W	10°19'20"
C80	417.00'	119.83'	119.42'	60.33'	S23°35'44"W	16°27'52"
C81	417.00'	237.49'	234.30'	122.06'	N48°08'37"E	32°37'53"
C82	417.00'	55.80'	55.76'	27.94'	S04°31'23"W	7°40'00"
C83	30.00'	13.89'	13.76'	7.07'	N77°25'37"E	26°31'31"
C84	65.00'	50.77'	49.49'	26.76'	N86°32'27"E	44°45'10"
C85	65.00'	63.92'	61.37'	34.81'	N42°54'42"W	56°20'33"
C86	65.00'	47.60'	46.54'	24.92'	S06°14'14"W	41°57'20"
C87	30.00'	13.89'	13.76'	7.07'	N13°57'09"E	26°31'31"
C88	20.00'	31.42'	28.28'	20.00'	N44°18'37"W	90°00'00"
C89	30.00'	13.89'	13.76'	7.07'	N12°34'23"W	26°31'31"
C90	65.00'	43.75'	42.93'	22.74'	S06°33'16"E	38°33'44"
C91	65.00'	65.00'	62.33'	35.51'	N41°22'28"E	57°17'45"
C92	65.00'	53.54'	52.04'	28.39'	S86°22'53"E	47°11'34"
C93	30.00'	13.89'	13.76'	7.07'	S76°02'51"E	26°31'31"
C94	20.00'	31.42'	28.28'	20.00'	S45°41'23"W	90°00'00"

Legend

- ⊕ = WITNESS CORNER MONUMENT
- = BOUNDARY LINE
- = LOT LINE
- - - = ADJOINING PROPERTY
- - - = EASEMENTS
- - - = SECTION TIE LINE
- SS = PROPOSED SANITARY SEWER LINE
- - EX.SS - - = EXISTING SANITARY SEWER LINE
- IRR = PROPOSED IRRIGATION WATER LINE
- - EX.IRR - - = EXISTING IRRIGATION WATER LINE (SIZE VARIES)
- W = PROPOSED CULINARY WATER LINE (SIZE VARIES)
- - EX.W - - = EXISTING CULINARY WATER LINE
- SD = PROPOSED STORM DRAIN (SIZE VARIES)
- - EX.SD - - = EXISTING STORM DRAIN
- LD = PROPOSED LAND DRAIN (SIZE VARIES)
- - EX.LD - - = EXISTING LAND DRAIN (SIZE VARIES)
- X = EXISTING FENCE LINE
- ■ ■ ■ ■ = PROPOSED TRAIL
- ⊕ = EXISTING FIRE HYDRANT
- = PROPOSED FIRE HYDRANT
- = EXISTING SANITARY SEWER/STORM DRAIN MANHOLE
- = PROPOSED SANITARY SEWER MANHOLE
- I = PROPOSED GATE VALVE
- ◆ = PLUG W/ 2" BLOW-OFF
- = PROPOSED STORM DRAIN MANHOLE
- = PROPOSED SINGLE GRATE CATCH BASIN WITH BICYCLE-SAFE GRATE
- ⊕ = PLUG & BLOCK
- ◆ = AIR-VAC ASSEMBLY
- ↘ = ROADWAY SLOPE
- [] = EXISTING STRUCTURE

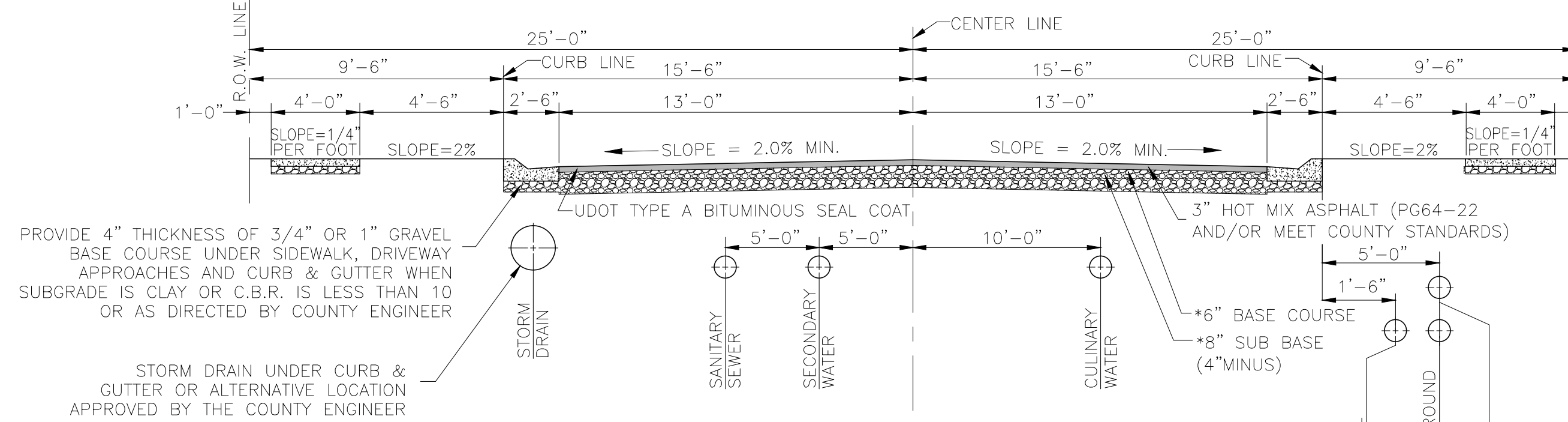

Street Section (50' R.O.W.)

SCALE: NONE
*VERIFY LOCATION WITH PHONE, GAS AND POWER COMPANIES.

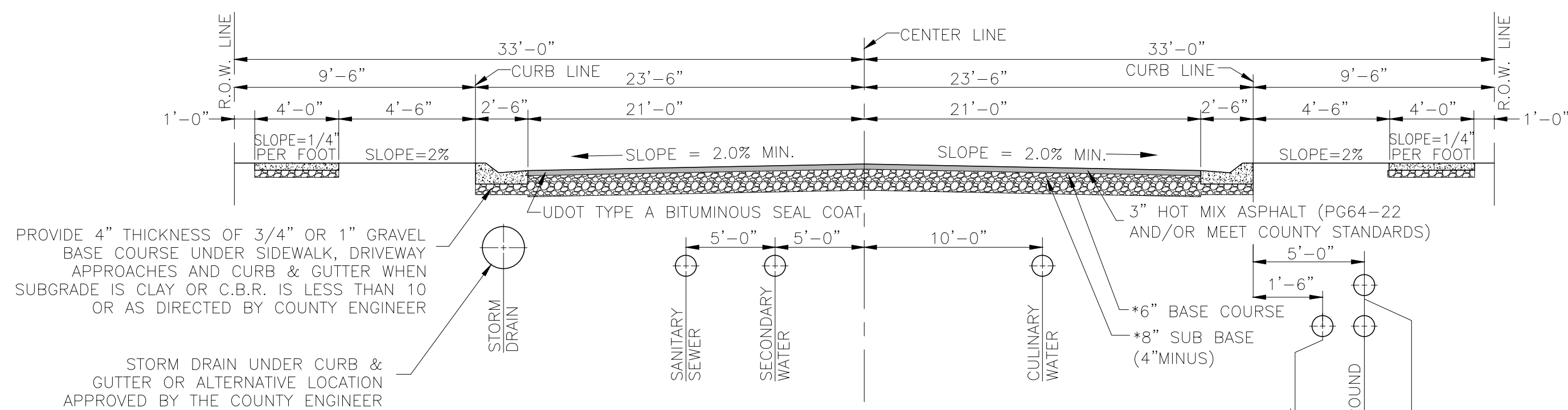

Street Section (66' R.O.W.)

SCALE: NONE
*VERIFY LOCATION WITH PHONE, GAS AND POWER COMPANIES.

Construction Notes:

- PVC 8" SS Slope = 0.40% MIN.
- PVC 10" SS Slope = 0.30% MIN.
- RCP 15" SD Slope = 0.32% MIN.
- RCP 18" SD Slope = 0.26% MIN.
- RCP 21" SD Slope = 0.21% MIN.
- RCP 24" SD Slope = 0.17% MIN.
- RCP 27" SD Slope = 0.15% MIN.
- RCP 30" SD Slope = 0.13% MIN.

Drainage Notes:

Detention Basin #1:
Watershed Area 134.58 AC.
Required Volume 294,902 Cu. ft.
Provided Volume 298,340 Cu. ft.</

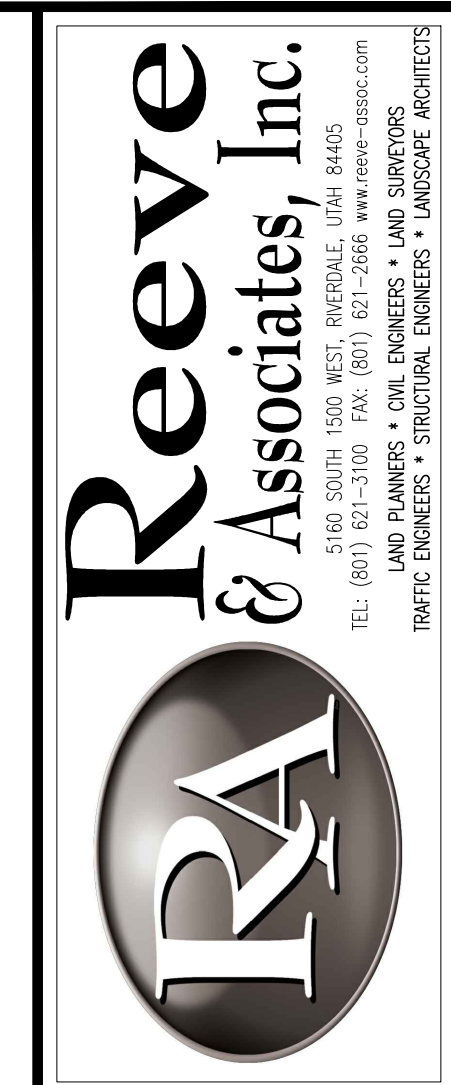

REVISIONS	DATE	DESCRIPTION
	07/21/17	JM Preim. Completed
	08/23/17	ER City Redlines
	10/2/17	ER Cluster Revised

Sunset Equestrian Cluster Subdivision
WEBER COUNTY, UTAH

Preliminary Plan

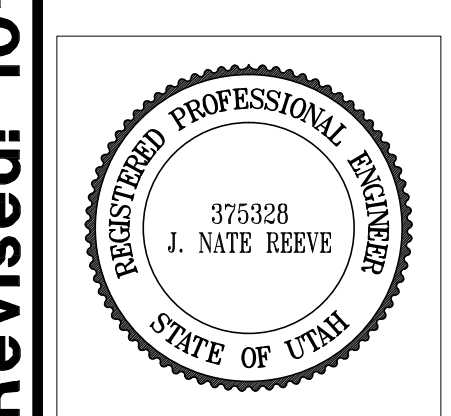

Project Info.

Engineer: N. REEVE
 Drafter: E. ROCHE
 Begin Date: 6-15-17
 Name: SUNSET EQUESTRIAN CLUSTER SUBDIVISION
 Number: 5336-05

Sheet	10
3	Sheets

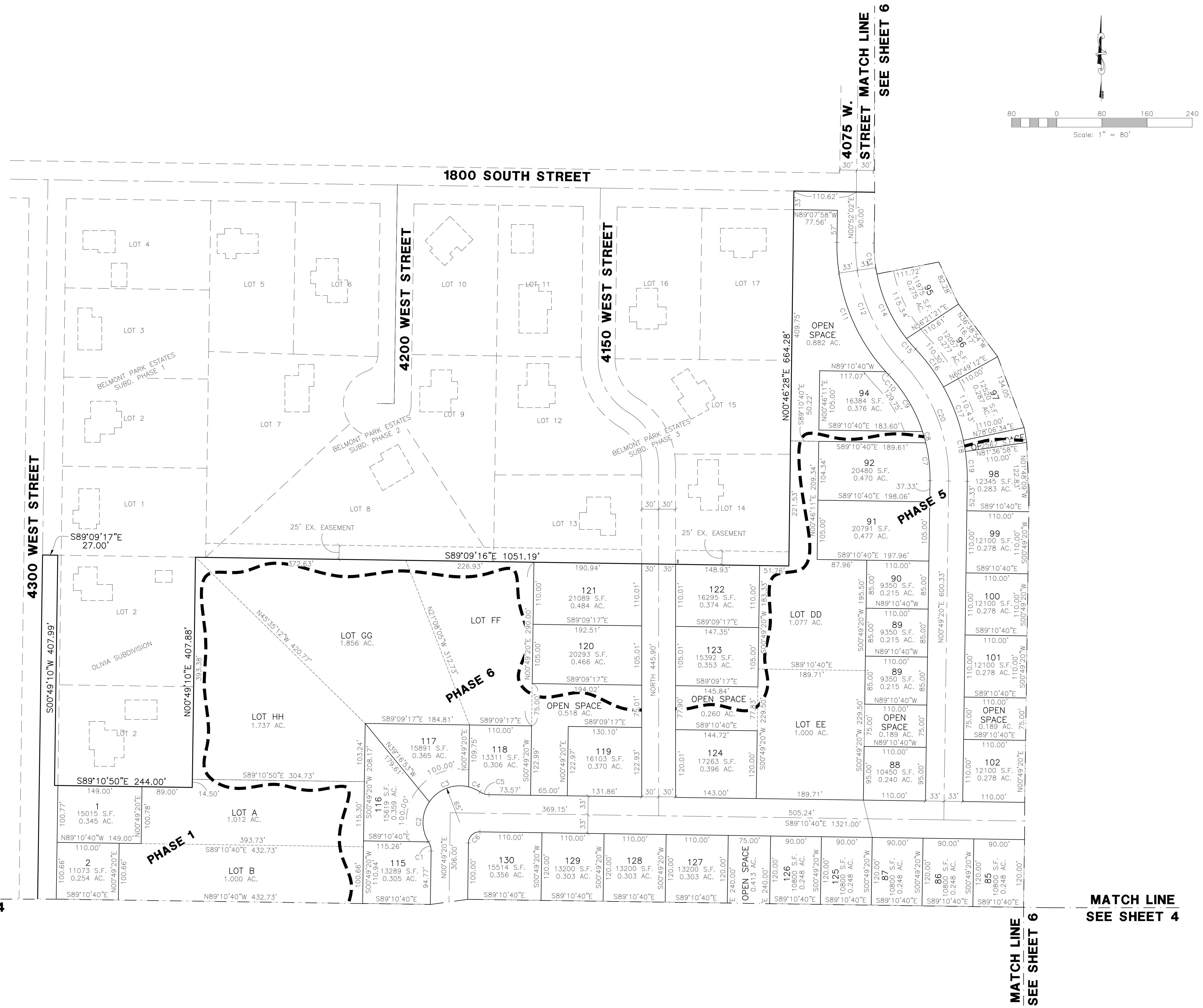
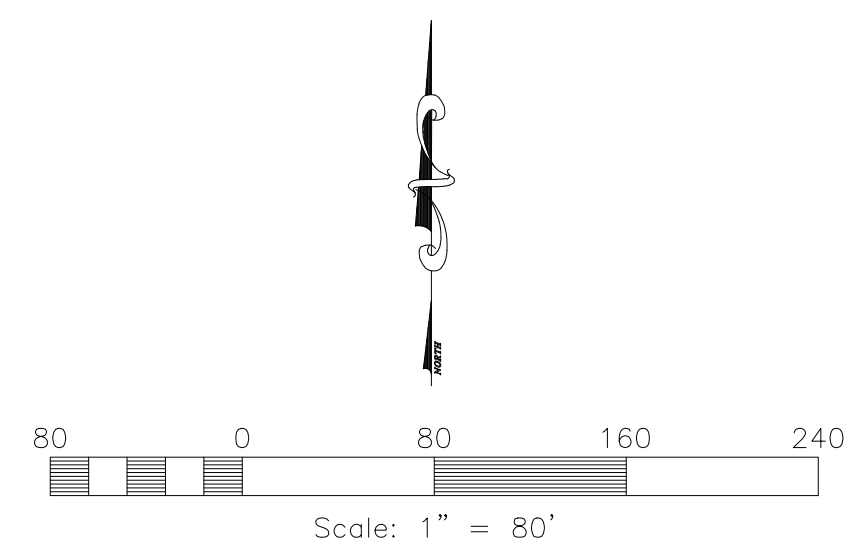

MATCH LINE
SEE SHEET 4

MATCH LINE
SEE SHEET 4

MATCH LINE
SEE SHEET 6

4075 W. STREET MATCH LINE
SEE SHEET 6

MATCH LINE
SEE SHEET 3

MATCH LINE
SEE SHEET 3

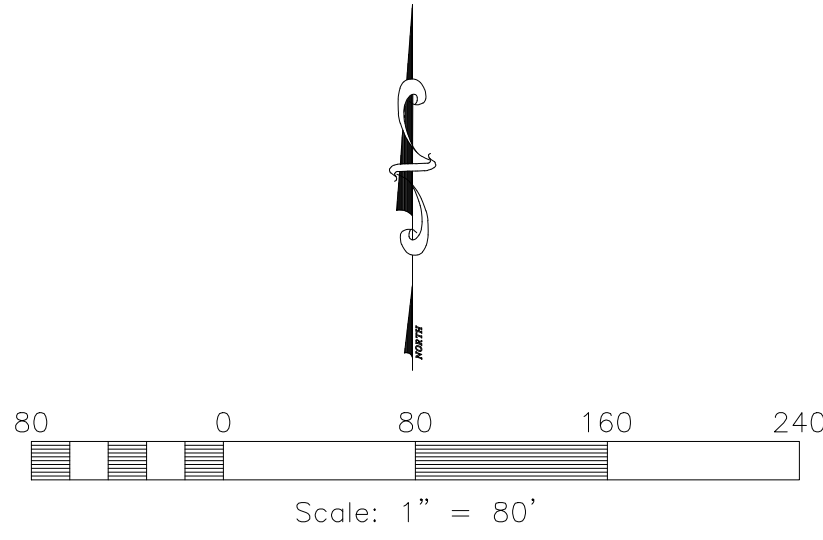

MATCH LINE
SEE SHEET 5

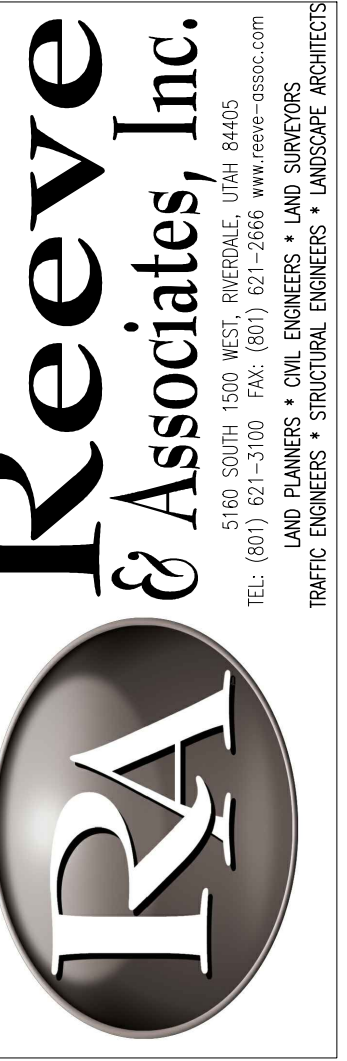

REVISIONS	DATE	DESCRIPTION
	07/21/17 JM	Preim. Completed
	08/23/17 ER	City Redlines
	10/2/17 ER	Cluster Revised

Sunset Equestrian Cluster Subdivision
WEBER COUNTY, UTAH

Preliminary Plan



Project Info.

Engineer:	N. REEVE
Drafter:	E. ROCHE
Begin Date:	6-15-17
Name:	SUNSET EQUESTRIAN CLUSTER SUBDIVISION
Number:	5336-05

MATCH LINE
SEE SHEET 6

MATCH LINE
SEE SHEET 4

MATCH LINE
SEE SHEET 6

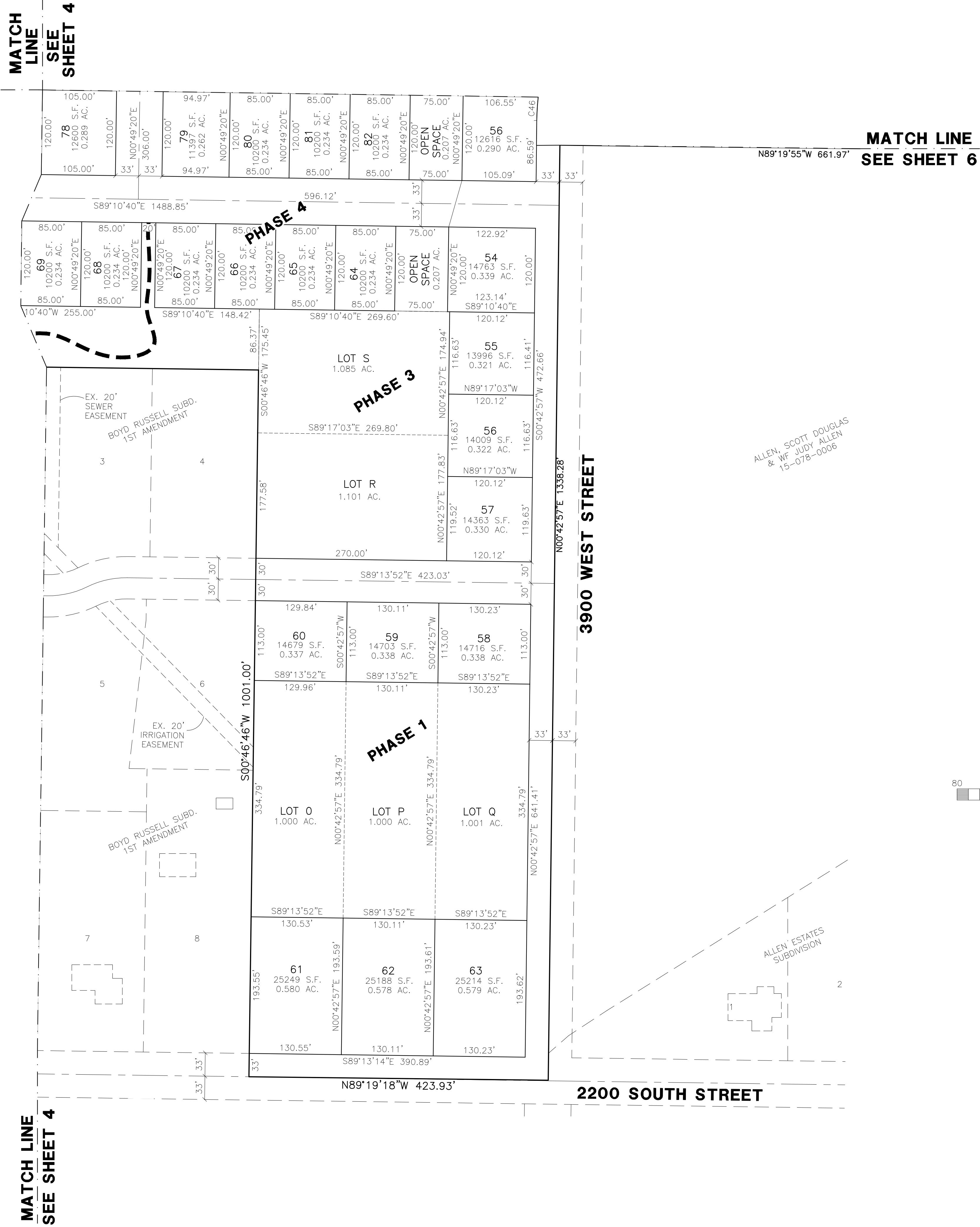

ALLEN, SCOTT DOUGLAS
& WIFE JUDY ALLEN
15-078-0006

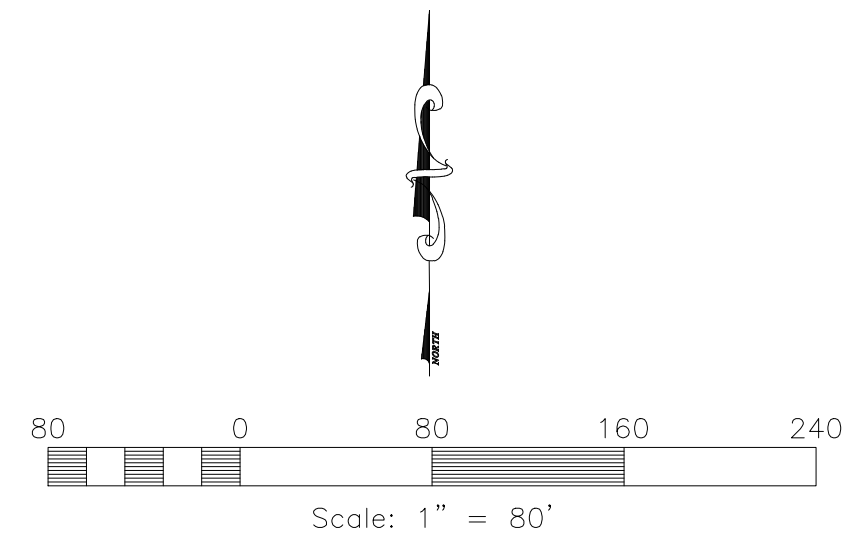

MATCH LINE
SEE SHEET 4

Revised: 10-2-17

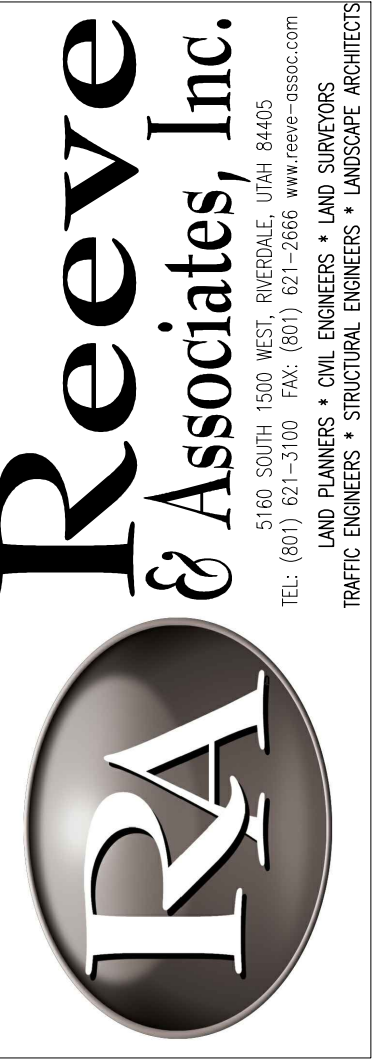

DATE	DESCRIPTION
07/21/17	JM Preim Completed
09/23/17	ER City Readiness
10/2/17	ER Cluster Revised

Sunset Equestrian Cluster Subdivision
WEBER COUNTY, UTAH

Preliminary Plan



Project Info.

Engineer: N. REEVE
 Drafter: E. ROCHE
 Begin Date: 6-15-17
 Name: SUNSET EQUESTRIAN CLUSTER SUBDIVISION
 Number: 5336-05

MATCH LINE
SEE SHEET 3

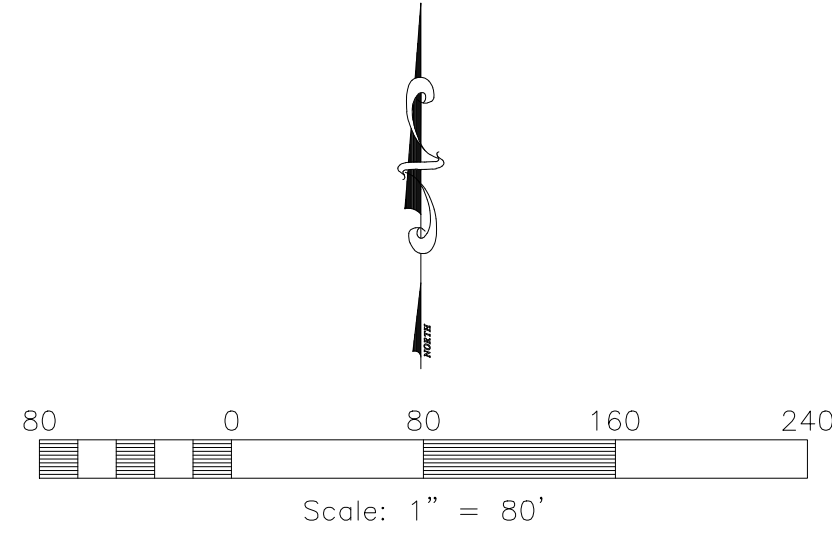
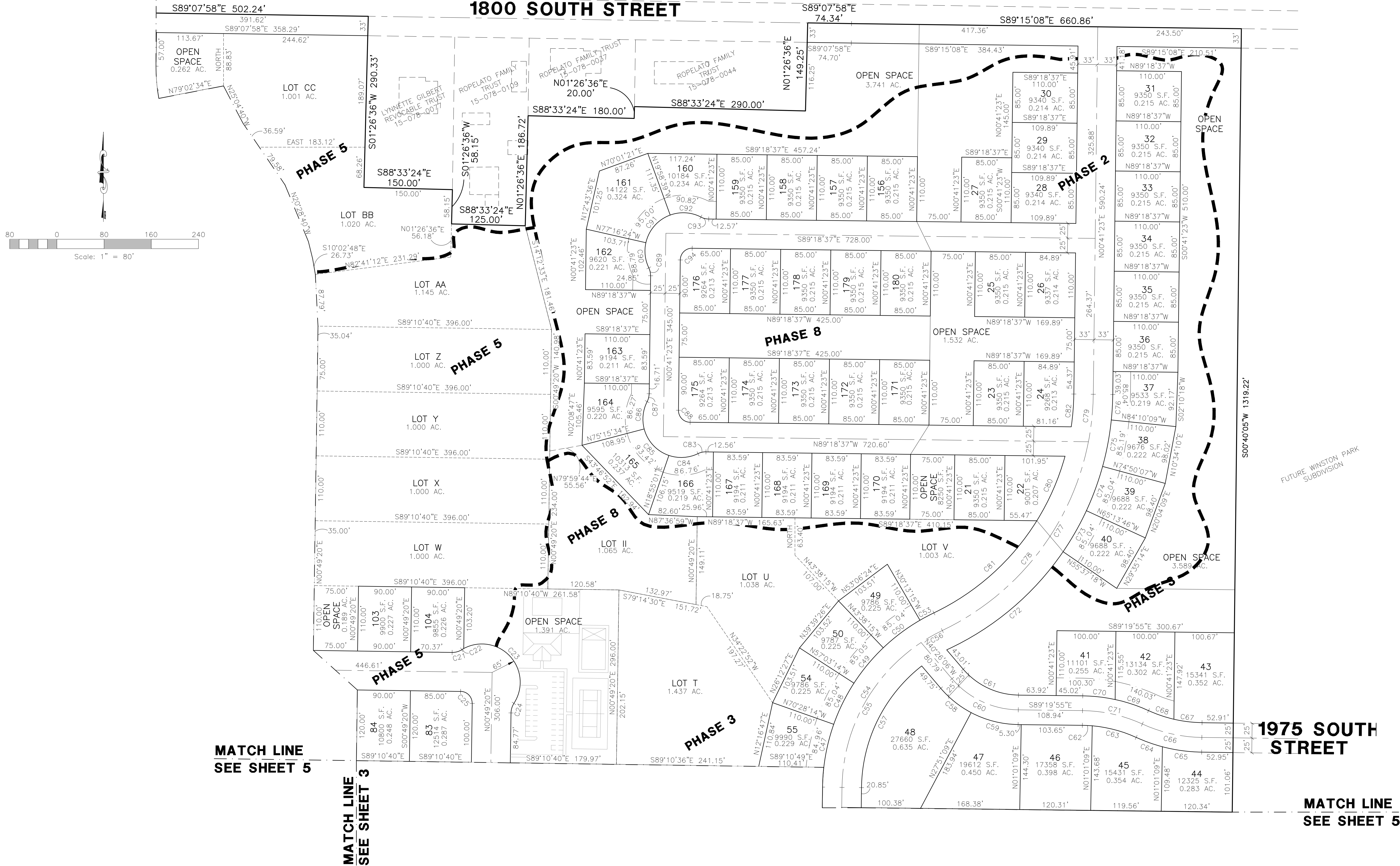

MATCH LINE
SEE SHEET 5

MATCH LINE
SEE SHEET 3

MATCH LINE
SEE SHEET 5

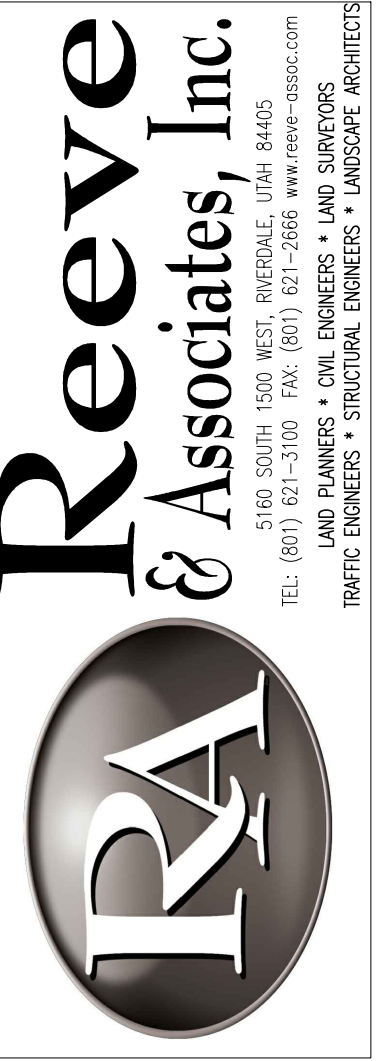

REVISIONS	DATE	DESCRIPTION
	07/21/17 JM	Perim. Completed
	06/23/17 ER	City Redlines
	10/21/17 ER	Cluster Revised

Sunset Equestrian Cluster Subdivision
WEBER COUNTY, UTAH
Preliminary Plan

Revised: 10-2-17

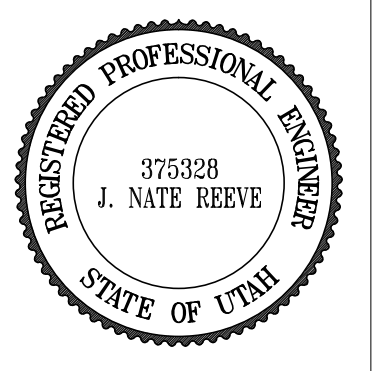

Project Info.	
Engineer:	N. REEVE
Drafter:	E. ROCHE
Begin Date:	6-15-17
Name:	SUNSET EQUESTRIAN CLUSTER SUBDIVISION
Number:	5336-05

Sheet	10
6	Sheets

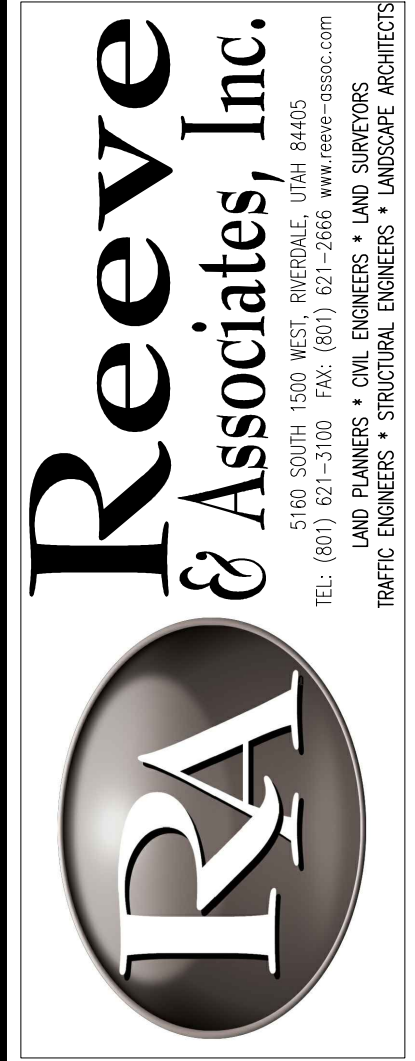
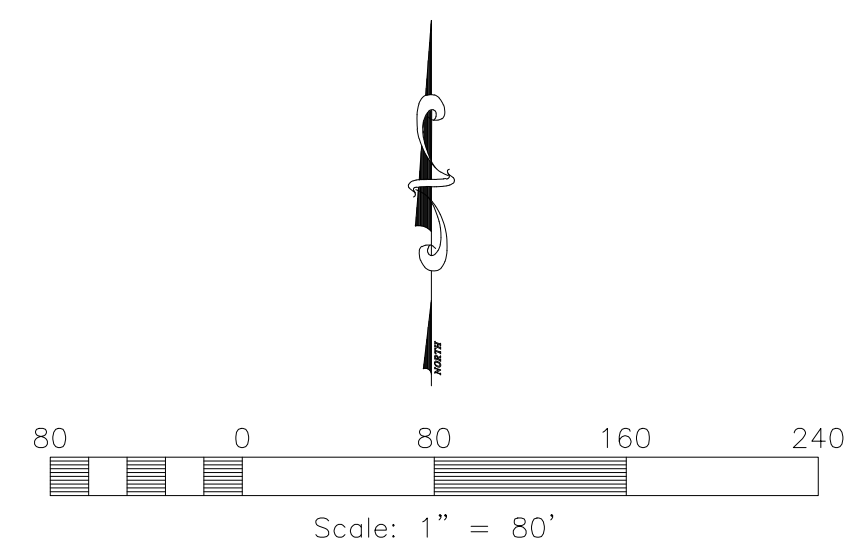

REVISIONS

DATE	DESCRIPTION
07/21/17 JM	Preim. Completed
09/23/17 ER	City Redlines
10/2/17 ER	Cluster Revised

Sunset Equestrian Cluster Subdivision
WEBER COUNTY, UTAH

Preliminary Utilities Plan

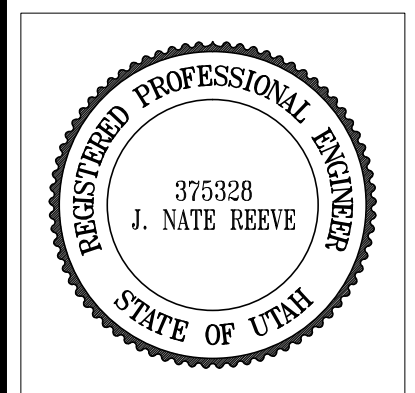

Project Info.
 Engineer: N. REEVE
 Drafter: E. ROCHE
 Begin Date: 6-15-17
 Name: SUNSET EQUESTRIAN CLUSTER SUBDIVISION
 Number: 5336-05

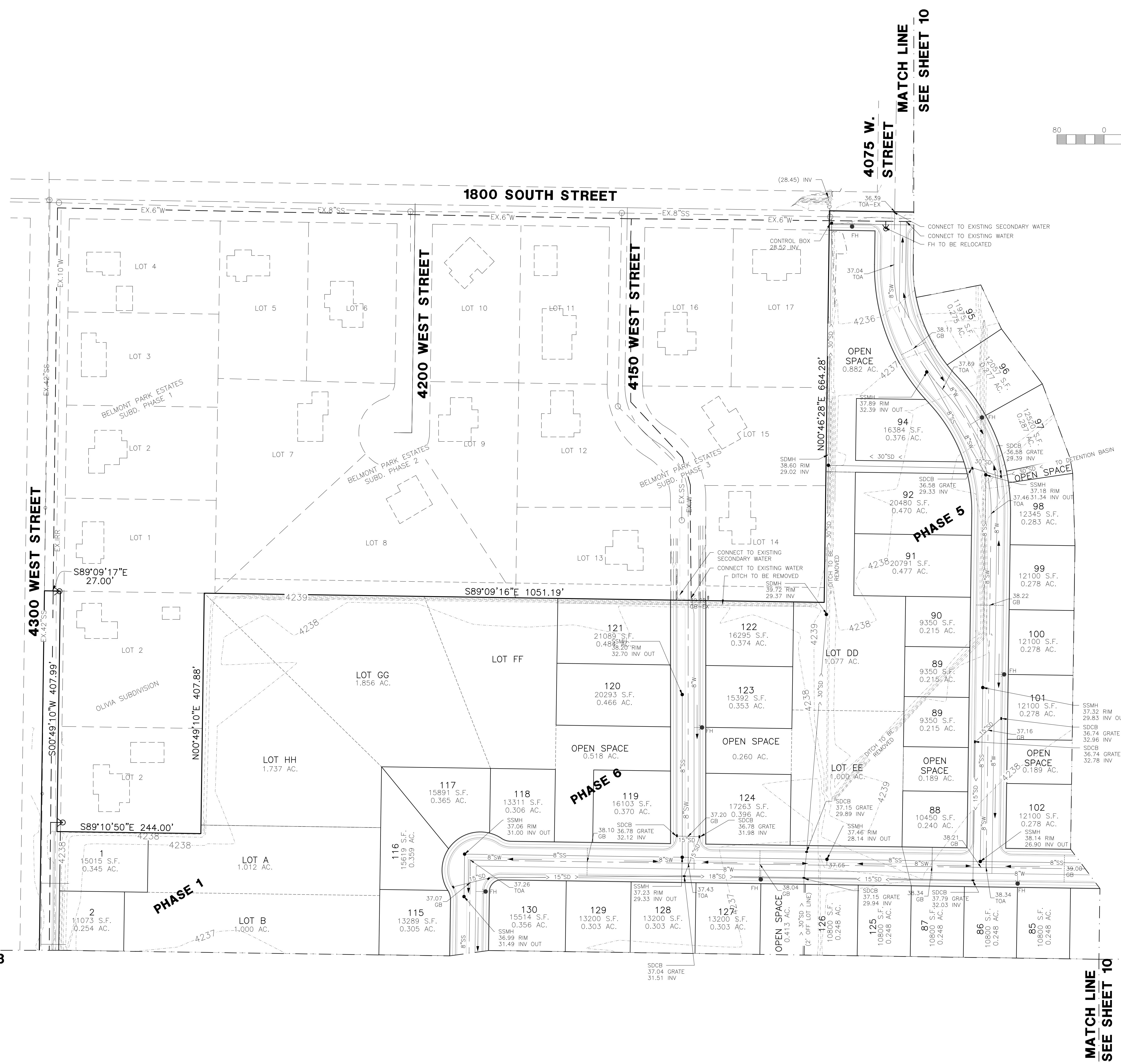

MATCH LINE
SEE SHEET 8

MATCH LINE
SEE SHEET 8

MATCH LINE
SEE SHEET 10

MATCH LINE
SEE SHEET 10

MATCH LINE
SEE SHEET 7

MATCH LINE
SEE SHEET 7

MATCH LINE
SEE SHEET 9

MATCH LINE
SEE SHEET 9

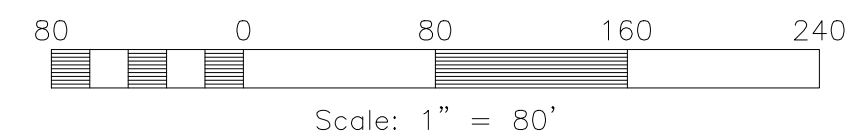

Reeve & Associates, Inc.

 5160 SOUTH 1500 WEST RIVERDALE, UTAH 84405
 TEL: (801) 921-2100 FAX: (801) 621-2666 WWW.REEVE-ASSOCIATES.COM
 LAND PLANNERS • CIVIL ENGINEERS • LAND SURVEYORS
 TRAFFIC ENGINEERS • STRUCTURAL ENGINEERS • LANDSCAPE ARCHITECTS

REVISIONS	DATE	DESCRIPTION
	07/21/17	JM Preim Completed
	06/23/17	ER City Redlines
	10/2/17	ER Cluster Revised

Reeve & Associates, Inc. - Solutions You Can Build On

Sunset Equestrian Cluster Subdivision
 WEBER COUNTY, UTAH

Preliminary Utilities Plan

Revised: 10-2-17

REGISTERED PROFESSIONAL ENGINEER
 375328
 J. NATE REEVE
 STATE OF UTAH

Project Info.

Engineer:	N. REEVE
Drafter:	F. ROCHE
Begin Date:	6-15-17
Name:	SUNSET EQUESTRIAN CLUSTER SUBDIVISION
Number:	5336-05

1/4/2016 | E:\Projects\5336\05_Preliminary\5336-05_Preliminary_09-28-17.dwg

MATCH LINE
SEE SHEET 10

MATCH LINE
SEE SHEET 8

MATCH LINE
SEE SHEET 10

NOTE: WHEN TEMPORARY LIFT STATION IS REMOVED, EXISTING SS LINE IS TO BE RE-ROUTED FROM WEST TO EAST

MATCH LINE
SEE SHEET 8

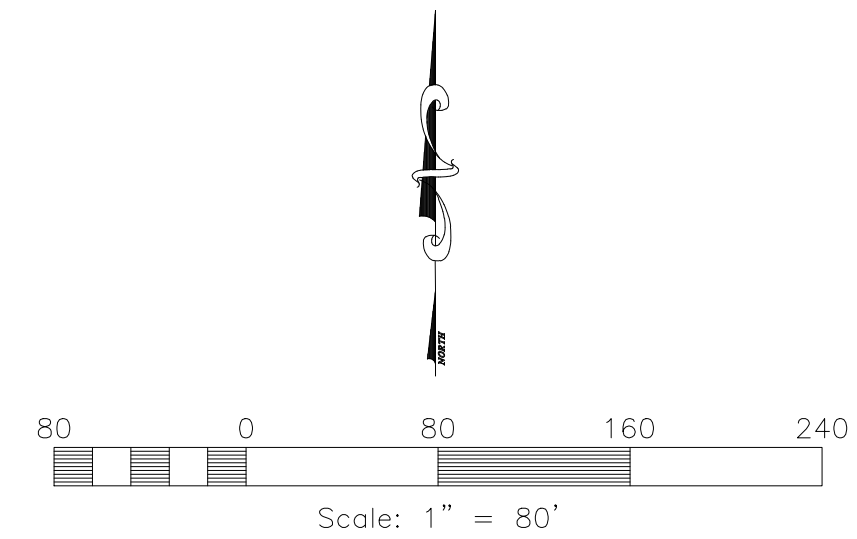
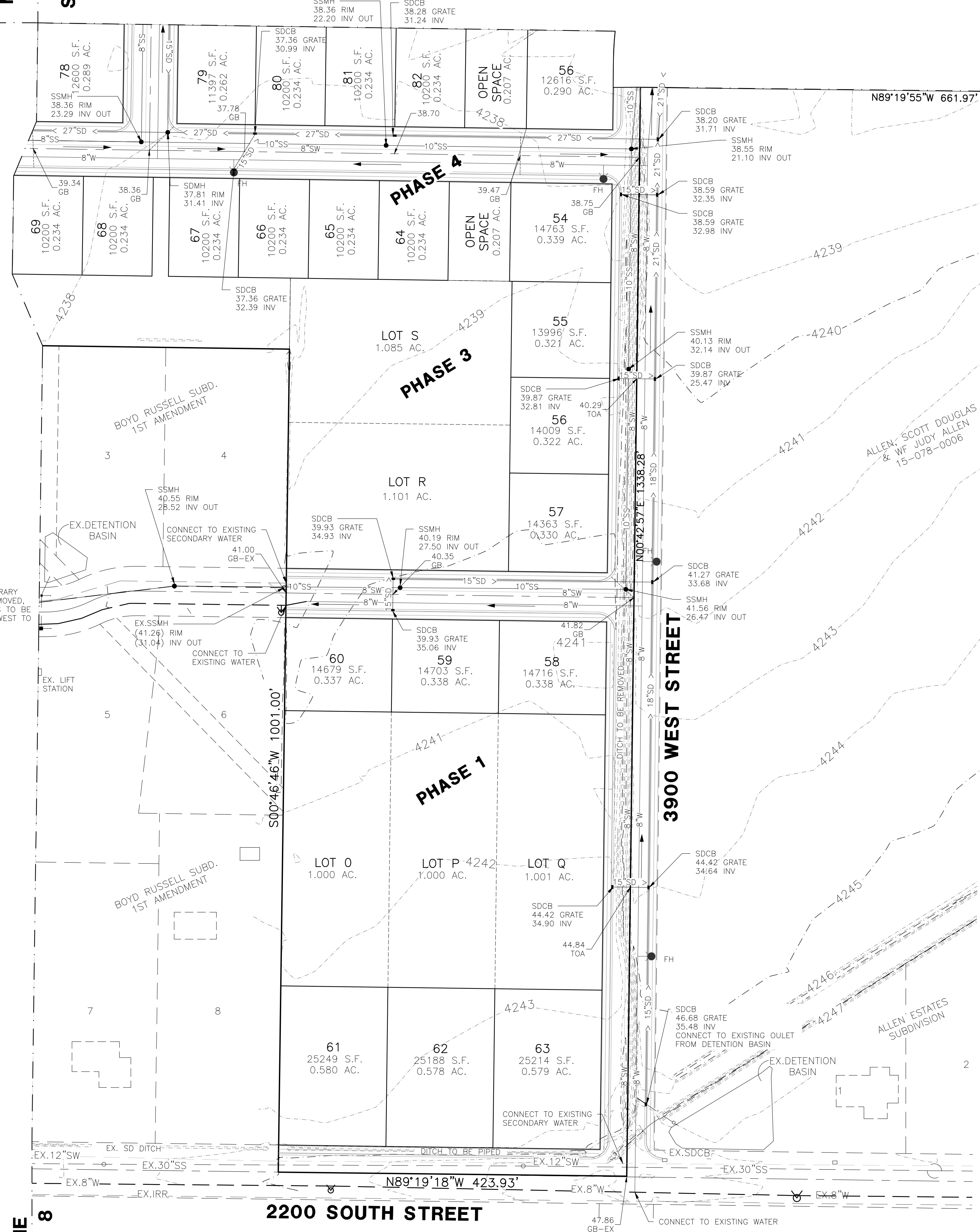

Revised: 10-2-17

Reeve & Associates, Inc.
IRA
 5160 SOUTH 1500 WEST RIVERDALE, UTAH 84405
 TEL: (801) 921-2100 FAX: (801) 921-2666 www.reeve-assoc.com
 LAND PLANNERS • CIVIL ENGINEERS • LAND SURVEYORS
 TRAFFIC ENGINEERS • STRUCTURAL ENGINEERS • LANDSCAPE ARCHITECTS

DATE	DESCRIPTION
07/21/17 JM	Preim. Completed
08/23/17 ER	City Redlines
10/2/17 ER	Cluster Revised

Sunset Equestrian Cluster Subdivision
 WEBER COUNTY, UTAH
Preliminary Utilities Plan



Project Info.

Engineer:	N. REEVE
Drafter:	F. ROCHE
Begin Date:	6-15-17
Name:	SUNSET EQUESTRIAN CLUSTER SUBDIVISION
Number:	5336-05

REVISIONS	DATE	DESCRIPTION
	07/21/17	JM Preim. Completed
	09/23/17	ER City Redlines
	10/2/17	ER Cluster Revised

Sunset Equestrian Cluster Subdivision
 WEBER COUNTY, UTAH
Preliminary Utilities Plan

Revised: 10-2-17

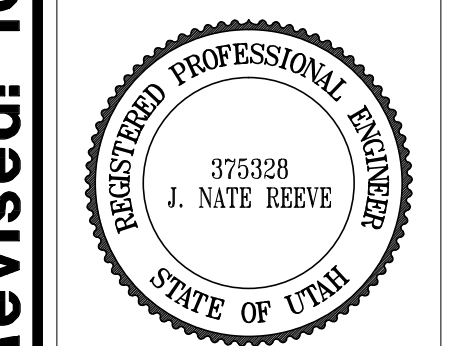

Project Info.

Engineer:	N. REEVE
Drafter:	F. ROCHE
Begin Date:	6-15-17
Name:	SUNSET EQUESTRIAN CLUSTER SUBDIVISION
Number:	5336-05

1/4/2016 | E:\5336\05\Preliminary\05-28-17.dwg | Reeve & Associates, Inc. - Solutions You Can Build On

MATCH LINE
SEE SHEET 7

MATCH LINE
SEE SHEET 9

MATCH LINE
SEE SHEET 7

MATCH LINE
SEE SHEET 9

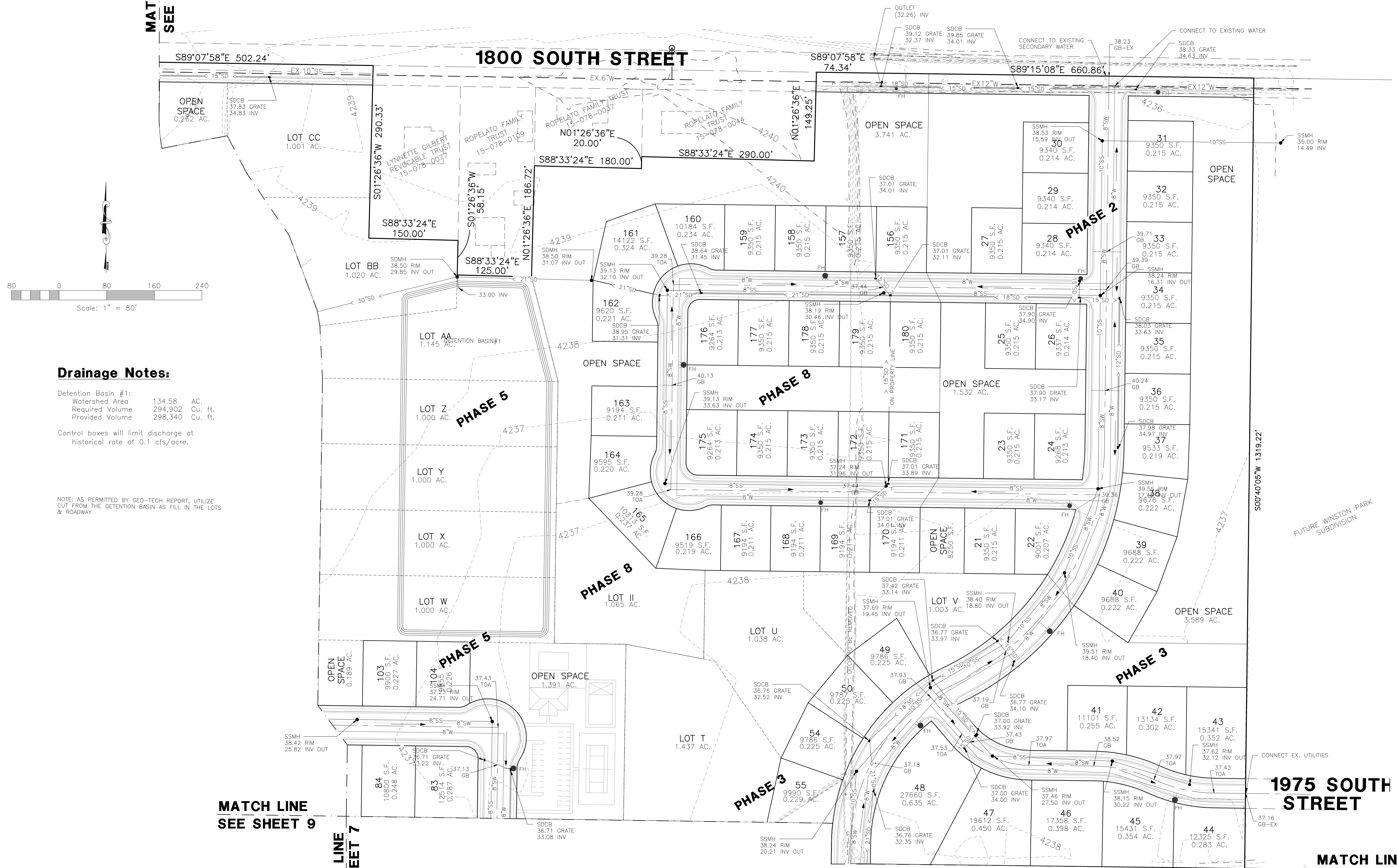

Drainage Notes:

Detention Basin #1:
 Watershed Area 134.58 AC.
 Required Volume 294,902 Cu. ft.
 Provided Volume 298,340 Cu. ft.

Control boxes will limit discharge at historical rate of 0.1 cfs/acre.

NOTE: AS PERMITTED BY GEO-TECH REPORT, UTILIZE CUT FROM THE DETENTION BASIN AS FILL IN THE LOTS & ROADWAY