



Land Use Permit

Weber County Planning Commission

2380 Washington Blvd. STE 240

Ogden, UT 84401

Phone: (801) 399-8791 FAX: (801) 399-8862

webercountyutah.gov/planning

Permit Number: LUP318-2017

Permit Type: Structure

Permit Date: 10/12/2017

Applicant

Name: Snowbasin Resort Company

Business:

Address: 3925 E Snowbasin Rd
Huntsville, UT 84317

Phone: 8016201018

Owner

Name: Same as applicant

Business:

Address: , UT

Phone:

Parcel

Parcel: 200430005

Zoning: DRR-1 **Area:** 1369.3 **Sq Ft:**

Address: , UT

Lot(s):

Subdivision:

T - R - S - QS: 6N - 1E - 29 - SE

Proposal

Proposed Structure: Parking lot

Proposed Structure Height: 0

of Dwelling Units:

Off Street Parking Req'd:

Building Footprint: 130000

Max Structure Height in Zone:

of Accessory Bldgs:

***Is Structure > 1,000 Sq. Ft?** N/A

***If True Need Certif. Statement**

Permit Checklist

Access Type: Across front lot line

Greater than 4218 ft above sea level? N/A

Additional Setback Req'd. ? N/A

> 200 ft from paved Road? N/A

Culinary Water District:

Alternative Access File #

Wetlands/Flood Zone? N/A

Meet Zone Area Frontage? N/A

Hillside Review Req'd? N/A

Waste Water System:

Comments

Land use permit issued based on compliance with land use code. The Ogden Valley Planning Commission approved the design review application on August 22, 2017.

Land Use Permit

Structure Setback Graphic: New Dwelling, Addition, Etc.

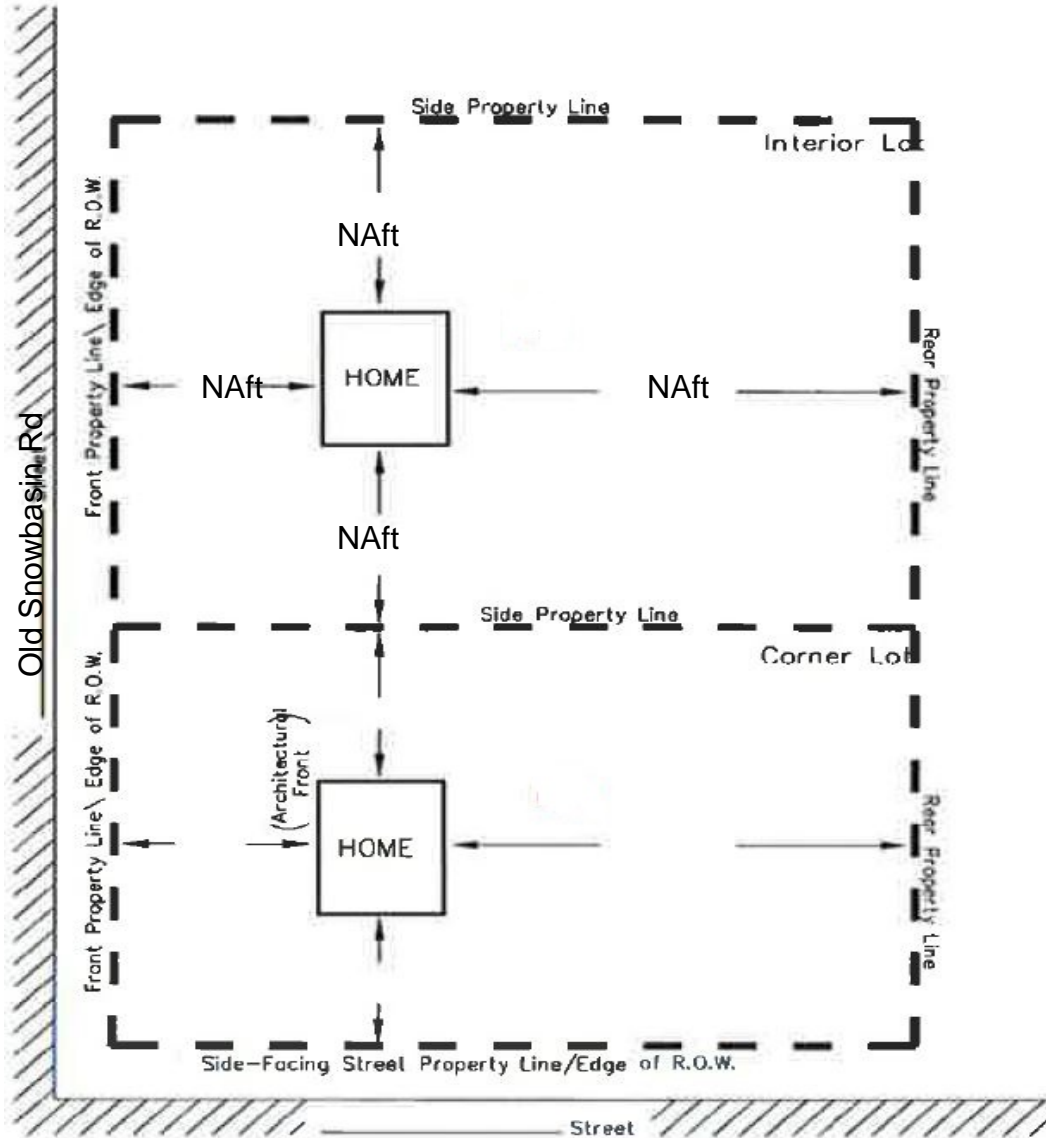

MINIMUM YARD SETBACKS New Dwelling, Addition, Etc.

NOTICE FOR APPLICANT (Please Read Before Signing)

Proposals for the installation of an individual water supply and for a sanitary waste disposal system (septic tank) for any structure designed for human occupation must be approved by Weber County Health Department prior to installation.

Steven Burton

10/12/2017

Planning Dept. Signature of Approval

Date

I hereby certify that I have read and examined this application and know the same to be true and correct. All provisions of laws and ordinances governing this land use will be complied with whether specified herein or not. I make this statement under penalty of perjury.

Contractor/Owner Signature of Approval

Date