



Land Use Permit

Weber County Planning Commission

2380 Washington Blvd. STE 240

Ogden, UT 84401

Phone: (801) 399-8791 FAX: (801) 399-8862

webercountyutah.gov/planning

Permit Number: LUP221-2017

Permit Type: Structure

Permit Date: 07/27/2017

Applicant

Name:

Business: Powdercat Townhomes, LLC

Address: 11180 Sunrise Valley Drive, Ste 300
Preston, VA 20191

Phone: 703-994-0931

Owner

Name:

Business: Powdercat Townhomes, LLC

Address: 11180 Sunrise Valley Drive
Preston, VA 20191

Phone: 703-994-0931

Parcel

Parcel: 231500001

Zoning: DRR-1 **Area:** .0609 **Sq Ft:** 2656 **Lot(s):** 124 **Subdivision:** Summit Eden Ph1C #4

Address: 8443 East Copper Crest Eden, UT 84310

T - R - S - QS: 7N - 2E - 8 - NE

Proposal

Proposed Structure: Townhome

Proposed Structure Height: 33

of Dwelling Units: 1

Off Street Parking Reqd: 1

Building Footprint: 1401

Max Structure Height in Zone: 75

of Accessory Bldgs: 0

***Is Structure > 1,000 Sq. Ft?** Yes

***If True Need Certif. Statement**

Permit Checklist

Access Type: Front lot line

Greater than 4218 ft above sea level? Yes

Additional Setback Reqd. ? No

> 200 ft from paved Road? No

Culinary Water District: PMWSD

Alternative Access File # N/A

Wetlands/Flood Zone? No

Meet Zone Area Frontage? Yes

Hillside Review Reqd? No

Waste Water System: PMWSD

Comments

A geologic hazards assessment has been performed and a report has been prepared by IGES dated January 16, 2017, identified as Project #01628-022. All site development will need to adhere to the geologic and geotechnical recommendations in the report. IGES engineering geologist and geotechnical engineer must observe the foundation excavation for the proposed townhome to confirm the absence of adverse geologic conditions in the area. Prior to issuing the Certificate of Occupancy, Weber County will record a "Notice of Natural Hazards Disclosure" against the property for future property owners information.

Land Use Permit

Structure Setback Graphic: New Dwelling, Addition, Etc.

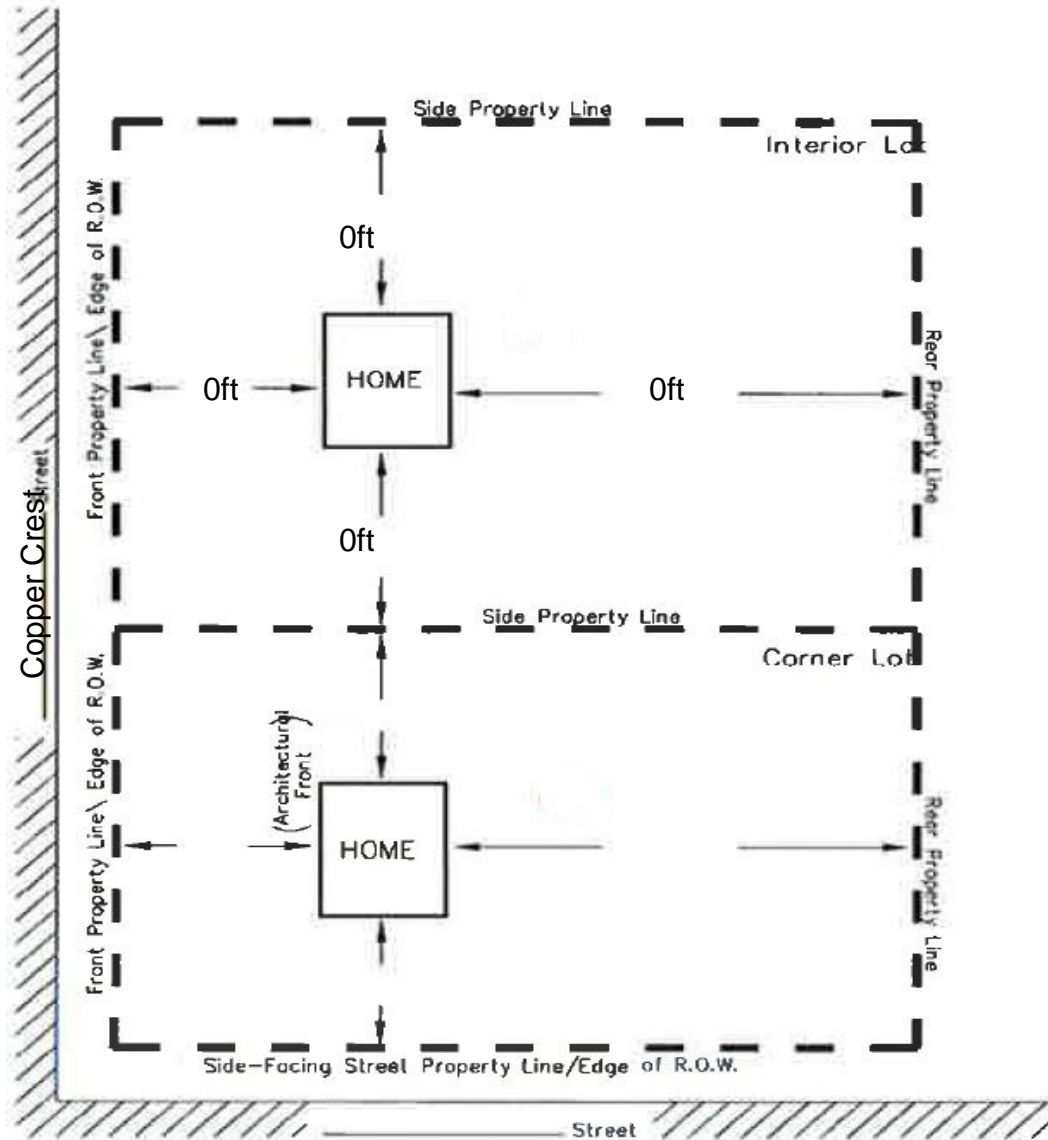

MINIMUM YARD SETBACKS New Dwelling, Addition, Etc.

NOTICE FOR APPLICANT (Please Read Before Signing)

Proposals for the installation of an individual water supply and for a sanitary waste disposal system (septic tank) for any structure designed for human occupation must be approved by Weber County Health Department prior to installation.

Ronda Kippen

07/27/2017

Planning Dept. Signature of Approval

Date

I hereby certify that I have read and examined this application and know the same to be true and correct. All provisions of laws and ordinances governing this land use will be complied with whether specified herein or not. I make this statement under penalty of perjury.

Contractor/Owner Signature of Approval

Date