

POWDERCAT TOWNHOMES – SUMMIT POWDER MOUNTAIN

TO:

Mr. Craig Browne, Building Official
 Weber County Building Inspection Department
 2380 Washington Blvd, Ste 240
 Ogden, UT 84401
 T (801) 399-8374

RE:

Powdercat Townhomes for Summit Powder Mountain
 1st Plan Review Resubmittal Narrative

DATE:

June 26, 2017



STUDIO MA
 ARCHITECTURE & ENVIRONMENTAL DESIGN

130 N CENTRAL AVENUE, NO.300
 PHOENIX, ARIZONA 85004
 TELEPHONE 602 251 3800
 FAX 602 251 3100

STUDIOMA.COM

DEAR MR. BROWNE:

Below, please find a narrative of revisions, additions, and clarifications for the above noted project per the WC3 First Review dated June 20, 2017.

CODE REVIEW COMMENTS

COMMENT	DESCRIPTION
A1.	Please show the dimensions of the building to the property lines. A. It appears that some of the building will be located closer than 5 feet to the property line (3 feet if sprinklered) and will require additional fire protection. If applicable please provide details showing how the fire rating is achieved for outside walls and the underside of eaves.
<i>Response</i>	<i>All areas around the building are dedicated open spaces, or public right of way per the approved plat. Moreover, the building is greater than 3' to each property line on the east, west, and south sides, and greater than 3' to centerline of the street on the north side, therefore all walls have a 0-hour rating – see dimensions on site plan sheet A1.00</i>
A2.	Sheet A0.01: Please address the following: A. The construction type is identified as “Type V”. Please detail on the plans whether the construction type is Type V-A or V-B. B. A note on the plans states “refer to building code analysis”. Has the structure been designed based upon the IBC or IRC? If the design is based upon the IBC, please provide a complete code analysis. I. Be aware, the review was performed based upon the 2015 IRC. C. Detail on the plans the overall square footage of each building and the entire structure.
<i>Response</i>	<i>Item A: Construction type is V-B – see revised sheet A0.01 and A0.10. Item B: Basis of design is 2015 IRC – see revised sheet A0.10.</i>



	<p><i>Item C: The project has been evaluated as a single structure, not separate buildings. Refer to revised sheet A1.20 for requested areas.</i></p>
A3.	<p>The three buildings are being connected by a roof over the two walkways. Based upon the assumption the design is based upon the 2015 IRC, please address the following:</p> <p>A. Due to the roof over the walkway, one of the exterior walls on either side of each walkway must be constructed as a fire-resistance rated wall (party/common wall). The common wall shall be constructed without penetrations through the rated wall. Based upon the fire sprinkler system, the wall shall be a 1-hour fire-resistance-rated wall assembly, per IRC R302.2 #1. Per R302.2.2 Exception, a parapet is not required where one of the conditions of code are met. Please detail on the plans:</p> <ol style="list-style-type: none"> I. Which of the exterior walls will be constructed as a fire-rated wall. II. How the requirements for the roof will be met, in lieu of the parapet.
Response	<p><i>Refer to imaginary property lines and dimensions on site plan, detail 2 on sheet A1.00; fire separation distance is greater than 3 feet, and fire sprinklers are provided in accordance with NFPA 13D.</i></p> <p><i>Item I: No exterior walls are required to be constructed as fire-rated walls.</i></p> <p><i>Item II: As per email correspondence with Building Official, a 1HR rated wall conforming to UL U305 has been indicated within the attic framing over the exterior wall at each side of the breezeways, typical. Refer to revised sheets A1.20 and A6.02 for indication of rated condition.</i></p>
A4.	<p>Identify on the floor plans the location of each required one-hour fire-rated common wall, per IRC R302.2.</p> <p>A. Detail the fire-rated roof design in lieu of a parapet, per IRC R302.2.2.</p> <p>B. While notes are provided on Sheet A0.10 regarding the party wall separation, provide a construction detail or the UL profile on the plans for UL U336.</p>
Response	<p><i>Refer to wall type D1 as indicated on floor plan sheets - see sheet A6.00 for wall type assembly. See sheet A1.20 for addition of rated wall line type at demising walls.</i></p> <p><i>Item A: As per exception to Section R302.2.2, fire rated wall may terminate at underside of roof sheathing where roof meets class C requirements and roof sheathing is fire treated wood. See "Chapter 3 Fire Resistant Construction" on code analysis, sheet A0.10. See also General Structural Notes, sheet S0.10.</i></p> <p><i>Item B: See wall type D1 sheet A6.00 and detail 3/A6.02.</i></p>
A5.	<p>Sheet A1.21: Please address the following:</p> <p>A. A typical unit area summary is identified on this sheet. Sheet A1.23 provides an area summary for Lot 24, and Sheet A1.25 provides an area summary for Lot 133. Please provide an area summary for each unit.</p>



Response	<i>Lots 127-132 are identical units - all areas are as per the "typical unit" on sheet A1.23; areas for similar lots 125 and 126 have been added to sheet A1.27.</i>
A6.	The exterior door to the balcony is required to have a landing on both sides of the door. The inside of the door currently does not meet this requirement. The landing must meet the requirements of IRC 311.3
Response	<i>As per exception to IRC R311.3.2, a top landing is not required at other exterior doors where a stairway of not more than 2 risers is located on the exterior side of the door, provided that the door does not swing over the stairway. See revised plans sheets A1.22, A1.24, and A1.26, and section sheets A2.00, A2.01 showing revision to two steps of maximum riser height 8" as per Utah amendments to IRC R311.7.4.1.</i>
A7.	Provide information about what type of fireplace is being install. Please provide the manufactures installation instructions.
Response	<i>Refer to specification section 10 30, sheet A0.22. See attached manufacturer product installation requirements.</i>
A8.	Because there are stairs leading up to the balcony, window F would be considered to be at the bottom of a stair landing and would be required to be tempered according to IRC308.4.7. The window schedule does not show this window being tempered. Please address. (would apply to unit 133 and 124)
Response	<i>Tempering is required at all hazardous locations as per Glazing Requirements in Code Analysis sheet A0.10 whether indicated on window schedule, or not; "T" has been added to windows adjacent to stairs/ramps on sheet A6.10.</i>
A9.	It appears that the mechanical equipment and electrical subpanel will be located under the stairs. Please address the following, A. Please show or note how the requirements for under stair protection will be met according to section IRC302.7 that the underside of the stairs will be B. Please verify the ceiling height at the equipment. Some equipment like the electrical panel require a minimum working height.
Response	<i>Item A: all soffits and walls are covered in 5/8" GWB as per wall types B1, B6, B1, and W11, and stair section 5/A2.10. Item B: No electrical panels are included in the utility rooms, however, where equipment requiring service is located where ceilings are 8'-6" AFF - see new section 7/A2.11.</i>
A10.	The bunks are contained by the pocket door and this area is considered a sleeping room. It is required to have a smoke/carbon monoxide detector just outside of sleeping rooms as well as inside every sleeping room. Please add a detector just outside of the bunk room.
Response	<i>Added; see updated sheet A1.51 and E2.0.</i>
A11.	Sheet A5.09: Please address the following: A. The roof plans are required to detail the requirements of IRC R806.5 for unvented attic and unvented enclosed rafter assemblies. Please make all necessary corrections.

<i>Response</i>	<i>All requirements of section R806.5 are met as per detail 3/A6.02; specified insulation within attic space is a Class II air barrier as per attached product data.</i>
-----------------	--

MECHANICAL REVIEW COMMENTS

COMMENT	DESCRIPTION
M1.	Per M502.4.4, the maximum length of the clothes dryer exhaust duct shall be 35 feet from the connection to the transition duct from the dryer to the outlet terminal. Please detail the length of the dryer duct on the plans.
<i>Response</i>	<i>Refer to new table listing dryer exhaust lengths on sheet M0.1.</i>
M2.	Detail on the plans that the water heater will be strapped within the upper and lower one-third of the appliance's vertical dimension, per IRC M1307.2
<i>Response</i>	<i>Refer to revised electric water heater detail, sheet P0.2.</i>



PLUMBING REVIEW COMMENTS

No plumbing review comments provided.

ELECTRICAL REVIEW COMMENTS

No electrical review comments provided.

ENERGY REVIEW COMMENTS

COMMENT	DESCRIPTION
A.	The RESchecks provided on Sheets A0.11 and A0.12 identify a metal roof with R50.4 cavity insulation and 12.5 continuous insulation, as well as a membrane roof with R-50.4 cavity insulation and an R-30 continuous insulation. I. Please refer to the comment regarding unvented attic assemblies and detail on the plans how the identified R-values are being achieved and ensure the same information is provided on the RESchecks. II. Detail on the plans what type of continuous insulation is being installed on the roof and how it meets the requirements of IRC R806.5.
<i>Response</i>	<i>Refer to revised REScheck sheets A0.11-A0.12 Item I: Refer to unvented attic description per response to comment A11. Item II: Continuous insulation is defined as per specification section 07 20</i>
B.	A separate REScheck should be provided for each structure. The current reports identify Lots 125-132, Lot 124, and Lot 133. The reports need to entail the thermal envelope for each individual structure, not individual lots. Please make necessary corrections.
<i>Response</i>	<i>Refer to revised REScheck sheets for evaluations as a single building for consistency with building code analysis.</i>
C.	R-48 soffit insulation is identified. Normally, a soffit would not accommodate the depth of R-48 insulation. Please detail on the plans how this is to be achieved.



Response	<i>Corrected in revised REScheck sheets. Soffit areas occur along north face of building above garage door and entry door niche – refer to section A-A/A2.00, B-B/A2.01, and specifications, fiberglass batt insulation has been shown and included as R-38.</i>
D.	The report identifies R-15 under slab insulation. However, the detail provided on Sheet A5.00 does not meet the requirements of the energy code. Keyed Note 3 identifies a ½” expansion joint filler and sealant. Per IECC R402.2.10, the top edge of the insulation installed between the exterior wall and the edge of the interior slab shall be permitted to be cut at a 45-degree angle away from the exterior wall. Please make necessary corrections to the plans to ensure the building thermal envelope meets the requirements of code.
Response	<i>Per R402.2.10, slab-on-grade floors may be insulated by any combination of insulation on the vertical face of the inside or <u>outside of the foundation wall</u>, under the slab, or extending out from the building. Insulation has been included below slab in addition to the required vertical insulation shown on the outside face of the foundation wall as per foundation detail 1/A5.00 and building section A2.00. No requirement for beveling insulation at slab edge should apply where required R-value is met with other compliant means.</i>
E.	Each door affecting the thermal envelope, including the door separating the garage and living space needs to be identified on the report. Please make necessary corrections.
Response	<i>Refer to revised REScheck sheets A0.11-A0.12.</i>
F.	Above-grade walls are identified with R-47.9 cavity insulation and R-8.4 continuous insulation. Please clarify how 1 ½” of insulation will achieve an R-47.9. Detail on the plans what type of continuous insulation is being applied to the exterior walls.
Response	<i>Refer to revised REScheck sheets A0.11-A0.12. Refer to wall types W1, W2, W5, W6, W9, W10, and W11, sheets A6.00 and A6.01, and specification section 07 20 – all exterior wall types indicate minimum 1.5” continuous insulation (3” where occurs) and minimum R21 cavity insulation. Per specification section 07 20, continuous insulation is mineral wool with an R-value of 6.5 for 1.5” thickness, and cavity insulation is fiberglass batt insulation.</i>
G.	The report identifies the demising wall with R-38 continuous insulation. I. The demising wall would be cavity insulation. II. The demising wall does not affect the thermal envelope of the structure. At best, the wall is being insulated for sound, not thermal value. Please correct.
Response	<i>Refer to revised REScheck sheets A0.11-A0.12.</i>
H.	Concrete “retaining” walls are identified with continuous R-15 insulation. Is the intention to identify the concrete basement walls? If so, the basement walls would normally be furred with 2X4 wood studs and “cavity” insulation installed. If some type of continuous insulation is being applied to the basement walls, please detail this information on the plans. Otherwise, please make necessary corrections.

Response	All basement walls are fully insulated on <u>exterior</u> vertical face of concrete wall with 3" rigid foam insulation having an R-value of 15 as per specification section 07 20.
I.	Ensure the plans and the REScheck provide the same thermal envelope information.
Response	Refer to revised REScheck sheets A0.11-A0.12.

WILDLAND URBAN INTERFACE COMMENTS

COMMENT	DESCRIPTION
General	An Ignition Resistant Construction Class must be established according to the Wildland-Urban Interface Code (IWUIC) Table 503.1. Appendix C of this code was completed, establishing the project as a Moderate Fire Hazard. According to the site plan it appears that 30 feet around the entire building will not be able to be maintained as a Conforming Defensible Space because of the proximity to property lines or other buildings. With this given information it can be determined that according to Table 503.1 the project will need to be an IR 2 or IR 3 construction depending on if a Conforming Water Supply according to IWUIC 404 is provided. This review was completed assuming the most stringent scenario, as an IR 1 construction. If a conforming water supply will be present please provide this information and respond to the bellow comments based on IR 2 construction.
Response	Per Weber Fire District previous approval of fire line infrastructure serving subdivision, water supply is "Conforming". Refer to attached recorded plat - no structures can occur within 30 feet of this building due to easements, streets, and designated open spaces; therefore, this project meets the requirements for IR-3 construction per table 503.1.
G1.	Please provide evidence that the roof covering will meet the requirement of a Class A roof assembly as required in IWUIC 504.2.
Response	Roof is required to meet Class A roof covering and either Class C roof assembly or <u>non-combustible roof covering</u> per IWUIC section 506.2. Per 2015 IBC table 1507.4.3(1), specified metal roof meets Class A roof covering and is non-combustible.
G2.	It appears that there will be wood siding as an exterior finish that may not be allowed for a Class 1 Ignition-Resistant Construction. Please verify and show that this material meets the requirements of IWUIC 504.5. If it doesn't meet this requirement please show a material that does.
Response	Per IWUIC section 506, no requirements are provided for exterior wall finish in IR-3 construction, therefore wood siding is permitted; no change required.
G3.	Please note on the plans that all vent openings through vertical exterior walls or through the roof cannot exceed 144 sq inches. Also note that these openings must be covered with a mesh that meets the requirements of IWUIC 504.10.
Response	All vents through roof or walls are less than 144 sq in. as per mechanical schedule sheets M0.1, and mechanical plan sheets for soffit grille at garage and entry vestibule.



G4.	It appears that a fireplace is being installed in the home. Please clarify what type of fireplace. If required, please note that a spark arrester will be provided that meets the requirements of IWUIC Section 605.
Response	<i>Refer to specification section 10.30 for fireplace and chimney requirements, and refer to keynote 2, detail 1, sheet A5.08 for spark arrester requirement.</i>

STRUCTURAL COMMENTS

Refer to separate response by structural engineer of record.

Please do not hesitate to contact me should you have any questions.

Sincerely,

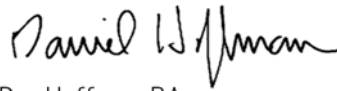

Dan Hoffman, RA
Studio Ma, Inc.

END OF MEMORANDUM



rudow + berry
structural engineering
 scottsdale, arizona 85251
 t (480) 946-8171
 f (480) 946-9480

job name: Powdercat
 job number: 17100

pg
 of

designed by: MAR
 checked by: MAR
 date: 6/17
 date:

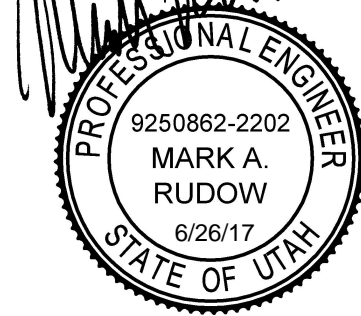

Summit Powder Mountain Townhomes
 Copper Crest East
 WC³ Project #217-525-086

Response to Plan Review Comments

Structural Drawings:

Comment S1: Please add a note to the plans stating that all fasteners (i.e. nails, screws, anchor bolts, etc.) which are to be installed in preservative treated wood (i.e. sill plates) shall meet the requirements of IBC 2304.10.5.

Response S1: See structural notes section III.C.10.a where the requirements of the referenced IBC section are already called out directly.

Comment S2: Please clarify how the shear walls are specified between units.

Response S2: See the shear wall schedule on sheet S0.12, note #1.

Comment S3: Sheet s0.12: The schedule calls for sheathing on each face of some shear walls yet they do not specify staggered edge nailing or 3x framing members as required by footnote 6 of Table 4.3A of AF&PA SDPWS. Please address.

Response S3: All walls that have the sheathing on both sides with 10d nails at 3" or less on center (types SW4 and SW5) are elevated on sheets S2.10 and S2.11. On these elevations, all studs are called out as 3x or greater thickness. In addition please see note #9 in the shear wall schedule on S0.12. This note has been further modified to require staggered nailing at panel edges.

Comment S4: Sheet s1.01: The large footings along gridline C do not meet the minimum reinforcement requirements of Section 13.3.2.1 and 7.6.1 of ACI 318-14. Please address.

Response S4: The footing reinforcement has been adjusted to meet the referenced code sections.

rudow + berry
structural engineering
scottsdale, arizona 85251
t (480) 946-8171
f (480) 946-9480

job name: Powdercat
job number: 17100

pg
of

designed by: MAR date: 6/17
checked by: date:

Structural Calculations:

Comment S5: The beams OHB 35, OHB 37, and OHB 38 do not match what is shown in the drawings. Please coordinate.

Response S5: These beams were change to steel due to detailing concerns and the wrong calculation sheets were inadvertently attached. Note that beam OHB-36 is also wrong. The correct calculations are attached following these responses. All sizes noted on the plans are correct.

Comment S6: Calculations for FB-9 show that a 5-1/8x13-1/2 glu-lam beam is required while the drawings show a 3-1/8x13-1/2 glu-lam beam. Please verify.

Response S6: The beam size has been corrected on the plans.

Comment S7: Please provide a vertical distribution of forces per Section 12.8.3 of ASCE 7-10.

Response S7: The requested distribution is already included for each unit on calculation sheet 240.

Comment S8: Calculations for Unit 124E/125W Upper Wall show that a 6'-0" wide footing is required. WF7 is shown at the upper wall footings. The WF7 is a 5'-0" wide footing. Please clarify. A. This applies to multiple units on the upper wall level.

Response S8: The incorrect footing marks at the upper walls on grids 2 and 3 have been corrected.

Comment S9: Calculations for Unit 124 South Shear Wall show that (4) MST48 straps are required. The drawings show (4) MST37 straps. Please coordinate.

Response S9: The strap size has been adjusted to match the calculations.

rudow + berry
structural engineering
scottsdale, arizona 85251
t (480) 946-8171
f (480) 946-9480

job name: Powdercat
job number: 17100

pg
of

designed by: MAR date: 6/17
checked by: date:

Comment S10: Calculations for the foundation at Unit 124 south wall show that a 7'-0" wide footing are required. The drawings show a WF4 which is a 4'-0" wide footing. Please address.

Response S10: I assume you are referring to the north wall of unit 124 for which both the plans and calculations show a 4'-0" wide footing. There are no wall footing calculations that require a 7'-0" footing. We have reviewed all of the north, south and far south wall footings and find that they match the calculations.

Comment S10A: Multiple shear wall footing calculations along the south wall show larger footings than what is shown in the plans. Please coordinate.

Response S10A: We have reviewed all of the south wall footings and do not find any that don't match the calculations.

Comment S11: Please verify that the deck joists have been designed for the support of a hot tub as shown in the architectural plans.

Response S11: The terrace floor structure has been designed to accommodate a certain maximum hot tub weight in addition to the worst case snow loads including drifting. We have added notes on our drawings that indicate an allowable load criteria based on the assumed hot tub we designed for.

Steel Beam

File = C:_jobs\17100C-1\ENGR\Framing\POWDER-1.EC6
ENERCALC, INC. 1983-2017, Build:6.17.2.28, Ver:6.17.2.28

Lic. #: KW-06002357

Licensee: RUDOW & BERRY

Description: Unit 133 - OHB-35 - W8x24

CODE REFERENCES

Calculations per AISC 360-10, IBC 2015, ASCE 7-10
Load Combination Set: ASCE 7-10 w/ ASD Wind & EQ

Material Properties

Analysis Method: Allowable Strength Design
Beam Bracing: Completely Unbraced
Bending Axis: Major Axis Bending

Fy: Steel Yield: 50.0 ksi
E: Modulus: 29,000.0 ksi

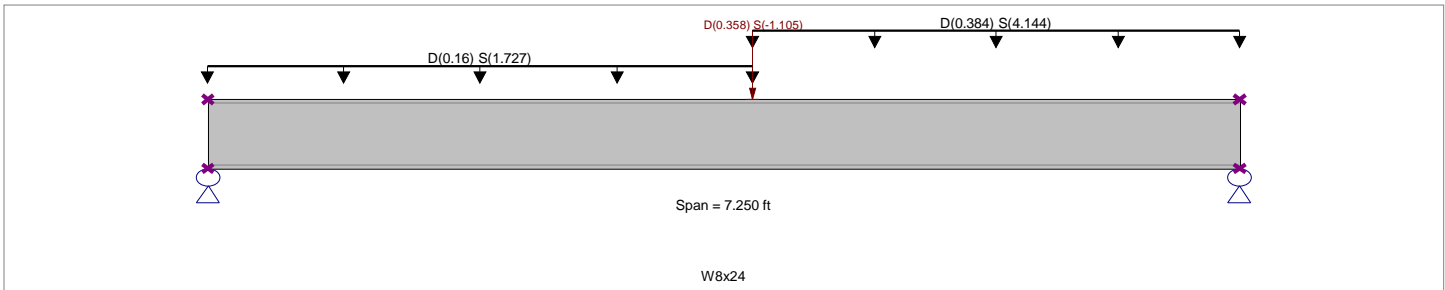

Applied Loads

Service loads entered. Load Factors will be applied for calculations.

Beam self weight calculated and added to loading

Load for Span Number 1

Uniform Load: D = 0.160, S = 1.727 k/ft, Extent = 0.0 --> 3.830 ft, Tributary Width = 1.0 ft

Uniform Load: D = 0.3840, S = 4.144 k/ft, Extent = 3.830 --> 7.250 ft, Tributary Width = 1.0 ft

Point Load: D = 0.3580, S = -1.105 k @ 3.830 ft

DESIGN SUMMARY

Design OK

Maximum Bending Stress Ratio =	0.344 : 1	Maximum Shear Stress Ratio =	0.346 : 1
Section used for this span	W8x24	Section used for this span	W8x24
Ma: Applied	19.825 k-ft	Va: Applied	13.435 k
Mn / Omega: Allowable	57.635 k-ft	Vn / Omega: Allowable	38.857 k
Load Combination	+D+S+H	Load Combination	+D+S+H
Location of maximum on span	4.309 ft	Location of maximum on span	7.250 ft
Span # where maximum occurs	Span # 1	Span # where maximum occurs	Span # 1
Maximum Deflection			
Max Downward Transient Deflection	0.067 in	Ratio =	1,291 >=360
Max Upward Transient Deflection	0.000 in	Ratio =	0 <360
Max Downward Total Deflection	0.077 in	Ratio =	1132 >=180
Max Upward Total Deflection	0.000 in	Ratio =	0 <180

Maximum Forces & Stresses for Load Combinations

Load Combination	Segment Length	Span #	Max Stress Ratios		Summary of Moment Values						Summary of Shear Values			
			M	V	Mmax +	Mmax -	Ma Max	Mnx	Mnx/Omega	Cb	Rm	Va Max	Vnx	Vnx/Omega
+D+H	Dsgn. L = 7.25 ft	1	0.044	0.037	2.54		2.54	96.25	57.63	1.19	1.00	1.44	58.29	38.86
+D+L+H	Dsgn. L = 7.25 ft	1	0.044	0.037	2.54		2.54	96.25	57.63	1.19	1.00	1.44	58.29	38.86
+D+Lr+H	Dsgn. L = 7.25 ft	1	0.044	0.037	2.54		2.54	96.25	57.63	1.19	1.00	1.44	58.29	38.86
+D+S+H	Dsgn. L = 7.25 ft	1	0.344	0.346	19.83		19.83	96.25	57.63	1.16	1.00	13.43	58.29	38.86
+D+0.750Lr+0.750L+H	Dsgn. L = 7.25 ft	1	0.044	0.037	2.54		2.54	96.25	57.63	1.19	1.00	1.44	58.29	38.86
+D+0.750L+0.750S+H	Dsgn. L = 7.25 ft	1	0.269	0.269	15.49		15.49	96.25	57.63	1.16	1.00	10.44	58.29	38.86
+D+W+H	Dsgn. L = 7.25 ft	1	0.044	0.037	2.54		2.54	96.25	57.63	1.19	1.00	1.44	58.29	38.86
+D+E+H	Dsgn. L = 7.25 ft	1	0.044	0.037	2.54		2.54	96.25	57.63	1.19	1.00	1.44	58.29	38.86
+D+0.750Lr+0.750L+0.750W+H	Dsgn. L = 7.25 ft	1	0.044	0.037	2.54		2.54	96.25	57.63	1.19	1.00	1.44	58.29	38.86
+D+0.750L+0.750S+0.750W+H	Dsgn. L = 7.25 ft	1	0.269	0.269	15.49		15.49	96.25	57.63	1.16	1.00	10.44	58.29	38.86
+D+0.750L+0.750S+0.750E+H	Dsgn. L = 7.25 ft	1	0.269	0.269	15.49		15.49	96.25	57.63	1.16	1.00	10.44	58.29	38.86

Steel Beam

File = C:_jobs\17100C-1\ENGR\Framing\POWDER-1.EC6
 ENERCALC, INC. 1983-2017, Build:6.17.2.28, Ver:6.17.2.28

Lic. #: KW-06002357

Licensee: RUDOW & BERRY

Description: Unit 133 - OHB-35 - W8x24

Load Combination	Segment Length	Span #	Max Stress Ratios		Summary of Moment Values						Summary of Shear Values			
			M	V	Mmax +	Mmax -	Ma Max	Mnx	Mnx/Omega	Cb	Rm	Va Max	Vnx	Vnx/Omega
+0.60D+W+0.60H														
Dsgn. L = 7.25 ft		1	0.026	0.022	1.53		1.53	96.25	57.63	1.19	1.00	0.86	58.29	38.86
+0.60D+E+0.60H														
Dsgn. L = 7.25 ft		1	0.026	0.022	1.53		1.53	96.25	57.63	1.19	1.00	0.86	58.29	38.86

Overall Maximum Deflections

Load Combination	Span	Max. "-" Defl	Location in Span	Load Combination	Max. "+" Defl	Location in Span
+D+S+H	1	0.0769	3.770		0.0000	0.000

Vertical Reactions

Support notation: Far left is #1

Values in KIPS

Load Combination	Support 1	Support 2
Overall MAXimum	8.705	13.435
Overall MINimum	0.610	0.865
+D+H	1.017	1.442
+D+L+H	1.017	1.442
+D+Lr+H	1.017	1.442
+D+S+H	8.705	13.435
+D+0.750Lr+0.750L+H	1.017	1.442
+D+0.750L+0.750S+H	6.783	10.436
+D+W+H	1.017	1.442
+D+E+H	1.017	1.442
+D+0.750Lr+0.750L+0.750W+H	1.017	1.442
+D+0.750L+0.750S+0.750W+H	6.783	10.436
+D+0.750L+0.750S+0.750E+H	6.783	10.436
+0.60D+W+0.60H	0.610	0.865
+0.60D+E+0.60H	0.610	0.865
D Only	1.017	1.442
Lr Only		
L Only		
S Only	7.689	11.993
W Only		
E Only		
H Only		

Steel Beam

File = C:_jobs\17100C-1\ENGR\Framing\POWDER-1.EC6
 ENERCALC, INC. 1983-2017, Build:6.17.2.28, Ver:6.17.2.28

Lic. #: KW-06002357

Licensee: RUDOW & BERRY

Description: Unit 133 - OHB-36 - W8x24

Load Combination	Segment Length	Span #	Max Stress Ratios		Summary of Moment Values						Summary of Shear Values			
			M	V	Mmax +	Mmax -	Ma Max	Mnx	Mnx/Omega	Cb	Rm	Va Max	Vnx	Vnx/Omega
Dsgn. L = 5.83 ft		1	0.009	0.009	0.49		0.49	96.25	57.63	1.14	1.00	0.34	58.29	38.86
+0.60D+E+0.60H														
Dsgn. L = 5.83 ft		1	0.009	0.009	0.49		0.49	96.25	57.63	1.14	1.00	0.34	58.29	38.86

Overall Maximum Deflections

Load Combination	Span	Max. "-" Defl	Location in Span	Load Combination	Max. "+" Defl	Location in Span
+D+S+H	1	0.0113	3.215		0.0000	0.000

Vertical Reactions

Support notation: Far left is #1

Values in KIPS

Load Combination	Support 1	Support 2
Overall MAXimum	0.663	4.564
Overall MINimum	0.228	0.336
+D+H	0.435	0.560
+D+L+H	0.435	0.560
+D+Lr+H	0.435	0.560
+D+S+H	0.663	4.564
+D+0.750Lr+0.750L+H	0.435	0.560
+D+0.750L+0.750S+H	0.606	3.563
+D+W+H	0.435	0.560
+D+E+H	0.435	0.560
+D+0.750Lr+0.750L+0.750W+H	0.435	0.560
+D+0.750L+0.750S+0.750W+H	0.606	3.563
+D+0.750L+0.750S+0.750E+H	0.606	3.563
+0.60D+W+0.60H	0.261	0.336
+0.60D+E+0.60H	0.261	0.336
D Only	0.435	0.560
Lr Only		
L Only		
S Only	0.228	4.004
W Only		
E Only		
H Only		

Steel Beam

File = C:_jobs\17100C-1\ENGFraming\POWDER-1.EC6
 ENERCALC, INC. 1983-2017, Build:6.17.2.28, Ver:6.17.2.28

Lic. #: KW-06002357

Licensee: RUDOW & BERRY

Description: Unit 124 - OHB-37 - W8x24

Load Combination	Segment Length	Span #	Max Stress Ratios		Summary of Moment Values						Summary of Shear Values			
			M	V	Mmax +	Mmax -	Ma Max	Mnx	Mnx/Omega	Cb	Rm	Va Max	Vnx	Vnx/Omega
Dsgn. L = 7.56 ft		1	0.048	0.040	2.79		2.79	96.25	57.63	1.18	1.00	1.56	58.29	38.86
Dsgn. L = 0.02 ft		1	0.001	0.040	0.03		0.03	96.25	57.63	1.00	1.00	1.57	58.29	38.86
+D+0.750Lr+0.750L+0.750W+H														
Dsgn. L = 7.56 ft		1	0.048	0.040	2.79		2.79	96.25	57.63	1.18	1.00	1.56	58.29	38.86
Dsgn. L = 0.02 ft		1	0.001	0.040	0.03		0.03	96.25	57.63	1.00	1.00	1.57	58.29	38.86
+D+0.750L+0.750S+0.750W+H														
Dsgn. L = 7.56 ft		1	0.303	0.296	17.46		17.46	96.25	57.63	1.17	1.00	11.50	58.29	38.86
Dsgn. L = 0.02 ft		1	0.004	0.298	0.25		0.25	96.25	57.63	1.00	1.00	11.58	58.29	38.86
+D+0.750L+0.750S+0.750E+H														
Dsgn. L = 7.56 ft		1	0.303	0.296	17.46		17.46	96.25	57.63	1.17	1.00	11.50	58.29	38.86
Dsgn. L = 0.02 ft		1	0.004	0.298	0.25		0.25	96.25	57.63	1.00	1.00	11.58	58.29	38.86
+0.60D+W+0.60H														
Dsgn. L = 7.56 ft		1	0.029	0.024	1.67		1.67	96.25	57.63	1.18	1.00	0.94	58.29	38.86
Dsgn. L = 0.02 ft		1	0.000	0.024	0.02		0.02	96.25	57.63	1.00	1.00	0.94	58.29	38.86
+0.60D+E+0.60H														
Dsgn. L = 7.56 ft		1	0.029	0.024	1.67		1.67	96.25	57.63	1.18	1.00	0.94	58.29	38.86
Dsgn. L = 0.02 ft		1	0.000	0.024	0.02		0.02	96.25	57.63	1.00	1.00	0.94	58.29	38.86

Overall Maximum Deflections

Load Combination	Span	Max. "-" Defl	Location in Span	Load Combination	Max. "+" Defl	Location in Span
+D+S+H	1	0.0935	3.963		0.0000	0.000

Vertical Reactions

Support notation : Far left is #1

Values in KIPS

Load Combination	Support 1	Support 2
Overall MAXimum	8.906	14.921
Overall MINimum	0.635	0.944
+D+H	1.058	1.573
+D+L+H	1.058	1.573
+D+Lr+H	1.058	1.573
+D+S+H	8.906	14.921
+D+0.750Lr+0.750L+H	1.058	1.573
+D+0.750L+0.750S+H	6.944	11.584
+D+W+H	1.058	1.573
+D+E+H	1.058	1.573
+D+0.750Lr+0.750L+0.750W+H	1.058	1.573
+D+0.750L+0.750S+0.750W+H	6.944	11.584
+D+0.750L+0.750S+0.750E+H	6.944	11.584
+0.60D+W+0.60H	0.635	0.944
+0.60D+E+0.60H	0.635	0.944
D Only	1.058	1.573
Lr Only		
L Only		
S Only	7.848	13.348
W Only		
E Only		
H Only		

Steel Beam

File = C:_jobs\17100C-1\ENGR\Framing\POWDER-1.EC6
ENERCALC, INC. 1983-2017, Build:6.17.2.28, Ver:6.17.2.28

Lic. #: KW-06002357

Licensee: RUDOW & BERRY

Description: Unit 124 - OHB-38 - W8x24

CODE REFERENCES

Calculations per AISC 360-10, IBC 2015, ASCE 7-10
Load Combination Set: ASCE 7-10 w/ ASD Wind & EQ

Material Properties

Analysis Method: Allowable Strength Design
Beam Bracing: Completely Unbraced
Bending Axis: Major Axis Bending

Fy: Steel Yield: 50.0 ksi
E: Modulus: 29,000.0 ksi

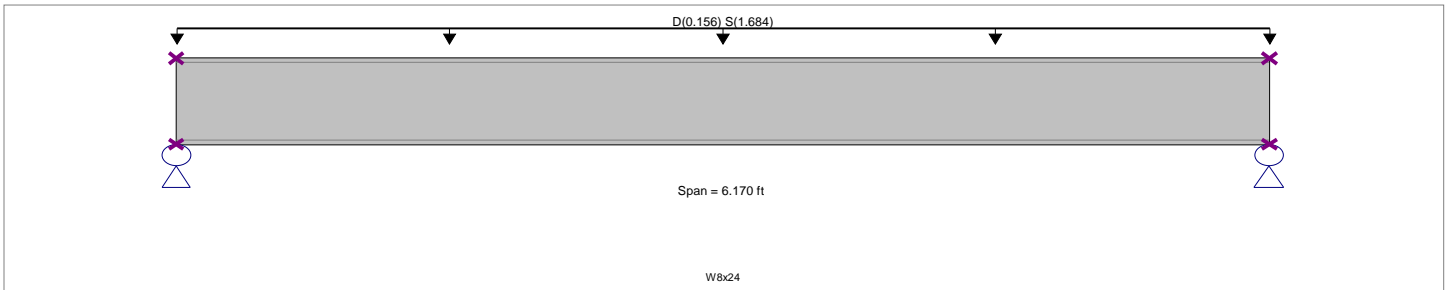

Applied Loads

Service loads entered. Load Factors will be applied for calculations.

Beam self weight calculated and added to loading
Uniform Load: D = 0.1560, S = 1.684 k/ft, Tributary Width = 1.0 ft

DESIGN SUMMARY

Design OK

Maximum Bending Stress Ratio =	0.154 : 1	Maximum Shear Stress Ratio =	0.148 : 1
Section used for this span	W8x24	Section used for this span	W8x24
Ma: Applied	8.870 k-ft	Va: Applied	5.750 k
Mn / Omega: Allowable	57.635 k-ft	Vn / Omega: Allowable	38.857 k
Load Combination	+D+S+H	Load Combination	+D+S+H
Location of maximum on span	3.085 ft	Location of maximum on span	0.000 ft
Span # where maximum occurs	Span # 1	Span # where maximum occurs	Span # 1
Maximum Deflection			
Max Downward Transient Deflection	0.023 in	Ratio =	3,219 >=360
Max Upward Transient Deflection	0.000 in	Ratio =	0 <360
Max Downward Total Deflection	0.025 in	Ratio =	2908 >=180
Max Upward Total Deflection	0.000 in	Ratio =	0 <180

Maximum Forces & Stresses for Load Combinations

Load Combination	Segment Length	Span #	Max Stress Ratios		Summary of Moment Values						Summary of Shear Values			
			M	V	Mmax +	Mmax -	Ma Max	Mnx	Mnx/Omega	Cb	Rm	Va Max	Vnx	Vnx/Omega
+D+H	Dsgn. L = 6.17 ft	1	0.015	0.014	0.86		0.86	96.25	57.63	1.14	1.00	0.56	58.29	38.86
+D+L+H	Dsgn. L = 6.17 ft	1	0.015	0.014	0.86		0.86	96.25	57.63	1.14	1.00	0.56	58.29	38.86
+D+Lr+H	Dsgn. L = 6.17 ft	1	0.015	0.014	0.86		0.86	96.25	57.63	1.14	1.00	0.56	58.29	38.86
+D+S+H	Dsgn. L = 6.17 ft	1	0.154	0.148	8.87		8.87	96.25	57.63	1.14	1.00	5.75	58.29	38.86
+D+0.750Lr+0.750L+H	Dsgn. L = 6.17 ft	1	0.015	0.014	0.86		0.86	96.25	57.63	1.14	1.00	0.56	58.29	38.86
+D+0.750L+0.750S+H	Dsgn. L = 6.17 ft	1	0.119	0.115	6.87		6.87	96.25	57.63	1.14	1.00	4.45	58.29	38.86
+D+W+H	Dsgn. L = 6.17 ft	1	0.015	0.014	0.86		0.86	96.25	57.63	1.14	1.00	0.56	58.29	38.86
+D+E+H	Dsgn. L = 6.17 ft	1	0.015	0.014	0.86		0.86	96.25	57.63	1.14	1.00	0.56	58.29	38.86
+D+0.750Lr+0.750L+0.750W+H	Dsgn. L = 6.17 ft	1	0.015	0.014	0.86		0.86	96.25	57.63	1.14	1.00	0.56	58.29	38.86
+D+0.750L+0.750S+0.750W+H	Dsgn. L = 6.17 ft	1	0.119	0.115	6.87		6.87	96.25	57.63	1.14	1.00	4.45	58.29	38.86
+D+0.750L+0.750S+0.750E+H	Dsgn. L = 6.17 ft	1	0.119	0.115	6.87		6.87	96.25	57.63	1.14	1.00	4.45	58.29	38.86
+0.60D+W+0.60H	Dsgn. L = 6.17 ft	1	0.009	0.009	0.51		0.51	96.25	57.63	1.14	1.00	0.33	58.29	38.86
+0.60D+E+0.60H	Dsgn. L = 6.17 ft	1	0.009	0.009	0.51		0.51	96.25	57.63	1.14	1.00	0.33	58.29	38.86

Steel Beam

File = C:_jobs\17100C-1\ENGI\Framing\POWDER-1.EC6
 ENERCALC, INC. 1983-2017, Build:6.17.2.28, Ver:6.17.2.28

Lic. #: KW-06002357

Licensee: RUDOW & BERRY

Description: Unit 124 - OHB-38 - W8x24

Load Combination	Segment Length	Span #	Max Stress Ratios		Summary of Moment Values						Summary of Shear Values			
			M	V	Mmax +	Mmax -	Ma Max	Mnx	Mnx/Omega	Cb	Rm	Va Max	Vnx	Vnx/Omega
Dsgn. L =	6.17 ft	1	0.009	0.009	0.51		0.51	96.25	57.63	1.14	1.00	0.33	58.29	38.86

Overall Maximum Deflections

Load Combination	Span	Max. "-" Defl	Location in Span	Load Combination	Max. "+" Defl	Location in Span
+D+S+H	1	0.0255	3.103		0.0000	0.000

Vertical Reactions

Support notation : Far left is #1

Values in KIPS

Load Combination	Support 1	Support 2
Overall MAXimum	5.750	5.750
Overall MINimum	0.333	0.333
+D+H	0.555	0.555
+D+L+H	0.555	0.555
+D+Lr+H	0.555	0.555
+D+S+H	5.750	5.750
+D+0.750Lr+0.750L+H	0.555	0.555
+D+0.750L+0.750S+H	4.452	4.452
+D+W+H	0.555	0.555
+D+E+H	0.555	0.555
+D+0.750Lr+0.750L+0.750W+H	0.555	0.555
+D+0.750L+0.750S+0.750W+H	4.452	4.452
+D+0.750L+0.750S+0.750E+H	4.452	4.452
+0.60D+W+0.60H	0.333	0.333
+0.60D+E+0.60H	0.333	0.333
D Only	0.555	0.555
Lr Only		
L Only		
S Only	5.195	5.195
W Only		
E Only		
H Only		

AMENDMENT # 2017-02-03.DWG
SY02
2014-1-16
NONE
N:\S\B0703\CADD\PHASE 1 PLAT AMENDMENTS\PHASE 1C AMENDMENTS\PLAT\FINAL\2016-11-30

SUMMIT EDEN PHASE 1C AMENDMENT 4

AMENDING LOTS 51R-56, 57B-62R, 116, PARCEL OS2 (OPEN SPACE) AND PARCEL N (OPEN SPACE)

THE NORTHEAST 1/4 OF SECTION 8, T. 7N., R. 2E., SLBM.
JANUARY 2017

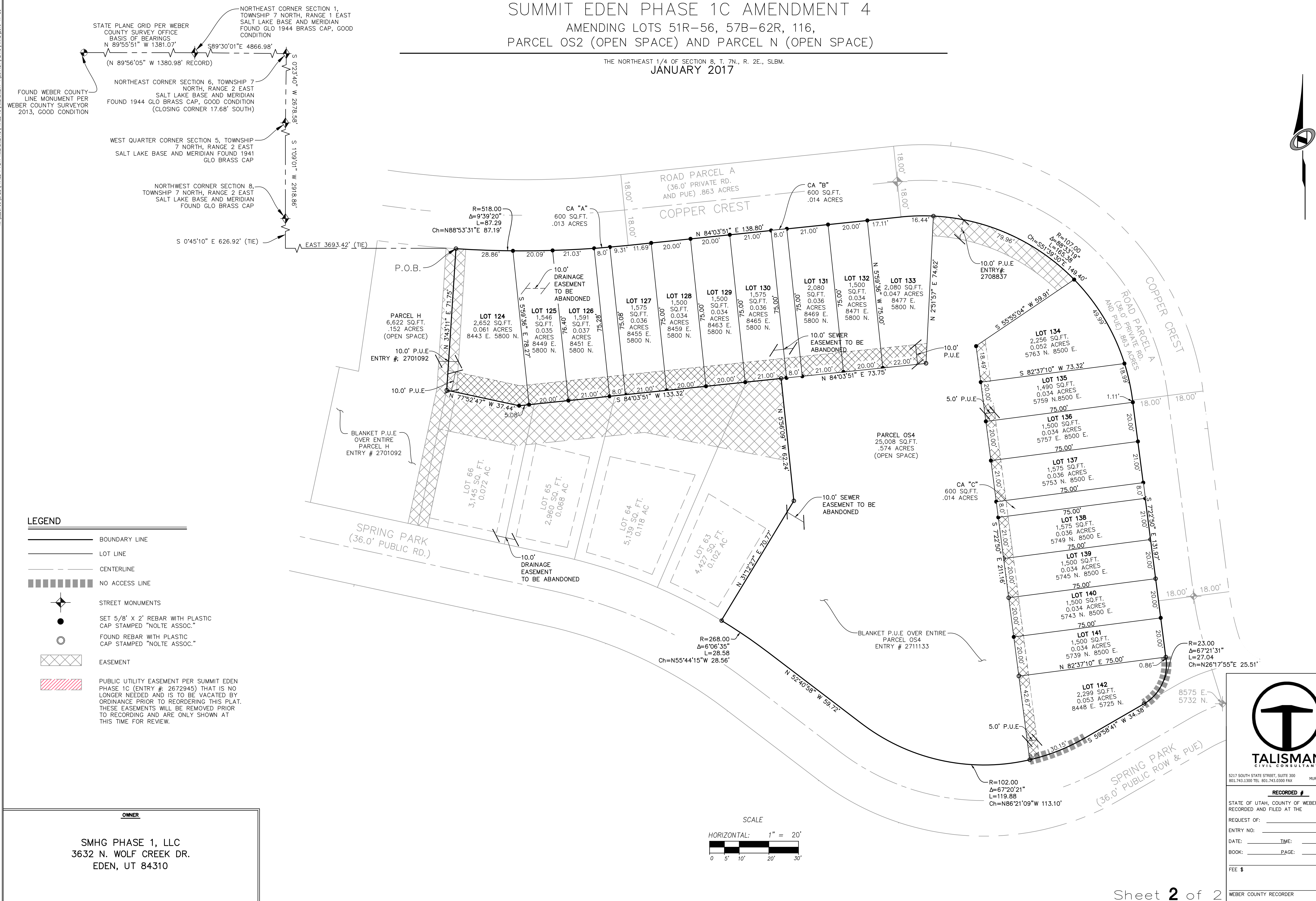

- LEGEND**
- BOUNDARY LINE
 - LOT LINE
 - CENTERLINE
 - NO ACCESS LINE
 - STREET MONUMENTS
 - SET 5/8" X 2" REBAR WITH PLASTIC CAP STAMPED "NOLTE ASSOC."
 - FOUND REBAR WITH PLASTIC CAP STAMPED "NOLTE ASSOC."
 - EASEMENT
 - PUBLIC UTILITY EASEMENT PER SUMMIT EDEN PHASE 1C (ENTRY # 2672945) THAT IS NO LONGER NEEDED AND IS TO BE VACATED BY ORDINANCE PRIOR TO REORDERING THIS PLAT. THESE EASEMENTS WILL BE REMOVED PRIOR TO RECORDING AND ARE ONLY SHOWN AT THIS TIME FOR REVIEW.

OWNER

SMHG PHASE 1, LLC
3632 N. WOLF CREEK DR.
EDEN, UT 84310

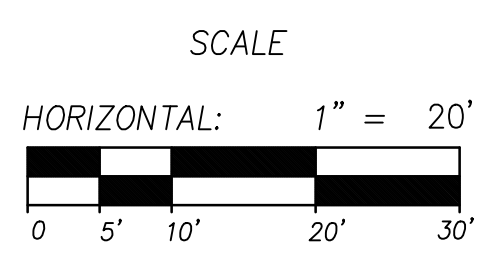

TALISMAN CIVIL CONSULTANTS

5217 SOUTH STATE STREET, SUITE 300
801.743.1300 TEL 801.743.0300 FAX MURRAY, UT 84107

RECORDED #

STATE OF UTAH, COUNTY OF WEBER,
RECORDED AND FILED AT THE

REQUEST OF: _____

ENTRY NO: _____

DATE: _____ TIME: _____

BOOK: _____ PAGE: _____

FEE \$ _____

WEBER COUNTY RECORDER

Malm Fireplaces, Inc.



368 Yolanda Avenue
Santa Rosa, Ca 95404
(707) 523-7755 - Fax: (707) 571-8036

Zircon 30

Tested to U/L Standard 737 & 1482

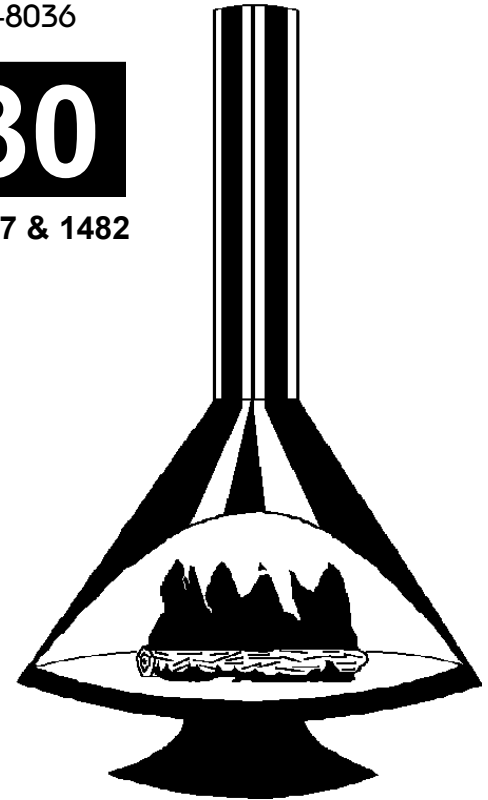

Assembly And Installation Instructions LEAVE THESE INSTRUCTIONS WITH THE OWNER.

SAFETY NOTICE

If this fireplace is not properly installed, a house fire may result. To reduce the risk of fire, follow the installation instructions. Contact local building or fire officials about restrictions and installation inspection requirements in your area.

This stove must be connected to (1) a chimney complying with the requirements for Type HT chimneys in the Standard for Chimneys, Factory-Built, Residential Type and Building Heating Appliance, UL 103, or (2) a code-approved masonry chimney with a flue liner.

Please read this entire manual before you install and use your new fireplace. Failure to follow instructions may result in property damage, bodily injury, or even death.

DO NOT INSTALL THIS UNIT IN A MOBILE HOME.

ASSEMBLY AND INSTALLATION INSTRUCTIONS

1. Carefully remove all components from the shipping cartons and inspect for damage. If any damage is noted contact the shipping company or your dealer immediately. **DO NOT INSTALL THIS UNIT IF DAMAGED OR MISSING PARTS.**
2. Protect the flooring near the intended place of installation with an old rug, blanket, or cardboard. Place the firebox on this material.
3. Mix and install the Malmcrete hearth refractory as follows:
 - a. Obtain a sturdy water-tight mixing container such as a wheelbarrow or large wash tub, a bucket or can for transporting the mixture, a cement trowel, and a source for clean mixing water. It is suggested that the Malmcrete be mixed outside to avoid spillage or splatters in the dwelling.
 - b. Pour the dry Malmcrete mixture into the mixing container.
 - c. Use 1 quart water for each bag.
 - d. Add 1/2 to 3/4 of the water to the dry mix and mix thoroughly. Add additional water in small increments, mixing thoroughly between additions. Do not add more water than is necessary to get a somewhat dry mixture; too much water in the mix may cause the refractory to crack excessively, and will reduce the strength of the refractory. To test for proper water content, cut vertically into the mixture with the trowel, push the trowel sideways to open a 3 inch deep by 2 inch wide cut in the mixture, then slide the trowel back up out of the cut. The cut should stay open with very little "slumping" back into the cut. Next, run the trowel over the surface of the mixture with the blade at a slight angle to the surface of the mixture, like spreading butter. The mixture should become relatively smooth with few voids after 6 or 7 passes of the trowel using moderate pressure. Water should not float to the top of the mixture.
 - e. Transfer the mixture to the hearth (floor) area inside the firebox, spreading the mixture out as it is added. Use the trowel to spread the mix into the firebox area. Continue to add refractory until there is a minimum of 2 inches thick over the entire hearth area. To measure the depth of the mix, place a piece of tape 2 inches from the pointed end of a long nail. Insert the nail vertically through the mix every 6 inches (front to back and side to side) across the hearth; the mix should come to a uniform height up the nail, at or slightly above the tape. Trowel in the nail holes when completed.
 - f. Allow the mix to cure at least 48 hours. Additional curing time is necessary in cool temperatures. The longer Malmcrete is allowed to cure before the first fire is lit, the stronger and more durable it will become.
 - g. Make the first 3 or 4 fires very small and of short duration to allow the refractory to adjust to the high temperature of a fire.

Hearth Requirements

A floor protector is required to protect the floor in front of the fireplace opening from sparks. The floor protector must be a minimum of 3/8 inch thick non-combustible material such as brick, concrete, slate, ceramic tile, or a listed floor protection board such as Wonderboard or Homosote.

The floor protector must extend a minimum of 16 inches in front of the fireplace opening and 8 inches to either side of the fireplace. The Zircon has been designed to provide floor protection allowing for flexible design of the hearth setting.

Clearance to Combustibles

The Zircon requires a clearance to combustible walls of 16" measured from the back of the unit. For locating the center of the chimney the measurement is 22 1/2" from the backwall and 47" to the sidewall. See figure 1, page 3. For corner installation the center of the chimney is 27". See figure 2, page 3.

Clearance to Non-combustibles

The Zircon clearance to a combustible wall may be reduced with proper wall protection. Accepted methods for wall protection would allow reduction of the wall clearances. For appearance if desired a non-combustible wall covering can be placed on the wall. The covering should consist of a listed wall protection board installed to the manufacturer's specifications. Approved protection boards at the time of this publication are Wonderboard, Dura Rock and Homosote. A non-combustible material can then be placed over the wall protection board. With most of the protection boards the clearance can be reduced to 8 inches from the original combustible wall. Be certain to check with your local building officials and or fire inspector for accepted methods in your area. Refer to NFPA 211.

CLEARANCES

SIDEWALL AND BACKWALL INSTALLATION

Unit to Sidewall -----	32"
Unit to Backwall -----	16"
Connector to Sidewall -----	43 1/2"
Center of Connector to Sidewall -----	47"
Connector to Backwall -----	18"
Center of connector to Backwall -----	21 1/2"

CORNER INSTALLATION

Unit to Adjacent Wall -----	16"
Connector to Adjacent Wall -----	23 1/2"
Center of Connector to Adjacent Wall -----	27"
Minimum Hearth Size -----	46" x 30 1/2"
Hearth is not required to extend under the Zircon's base.	

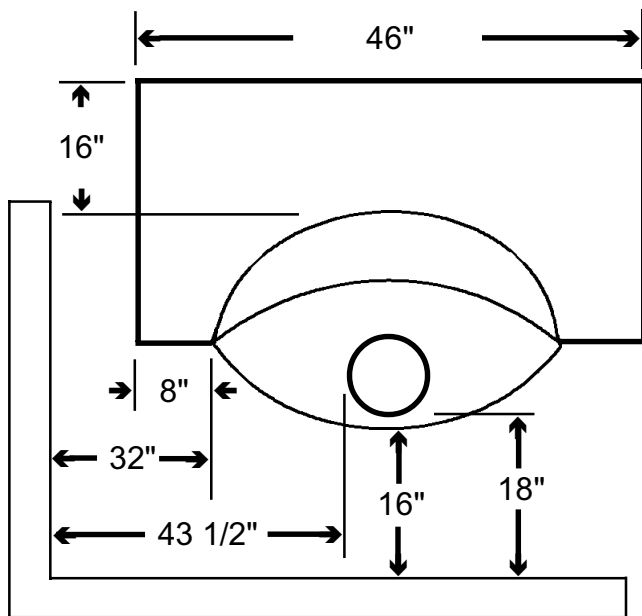

Figure 1

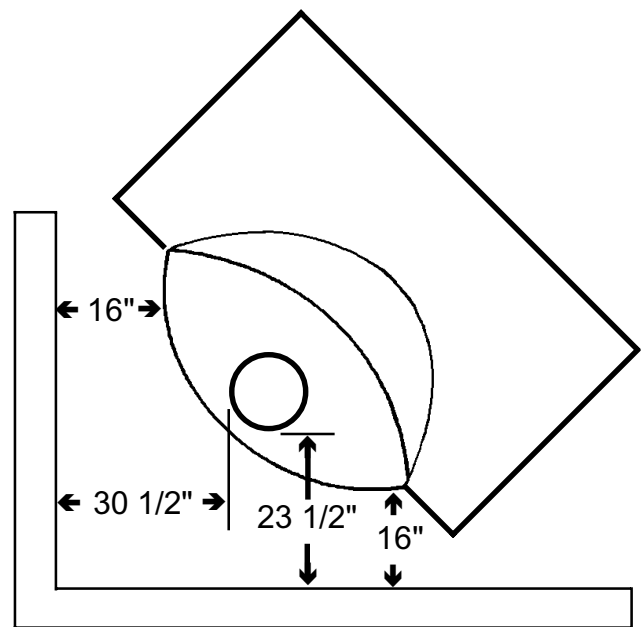

Figure 2

Hearth dimensions shown are minimum requirements. It may be desired to exceed these minimum dimensions for a more decorative installation. The hearth material must be 3/8" or thicker noncombustible material. It is not required for the hearth material to extend under the base of the fireplace.

ASSEMBLY AND INSTALLATION INSTRUCTIONS Continued

DO NOT CONNECT THIS UNIT TO A CHIMNEY FLUE SERVING ANOTHER APPLIANCE.

This stove must be connected to (1) a chimney complying with the requirements for Type HT chimneys in the Standard for Chimneys, Factory-Built, Residential Type and Building Heating Appliance, UL 103, or (2) a code-approved masonry chimney with a flue liner.

DO NOT CONNECT TO ANY AIR DISTRIBUTION DUCT OR SYSTEM.

Chimney Connector Installation

The connector pipe included with the Zircon is 1 - 7" x 24" damper pipe, 1 - 7" x 24" pipe section and 1 - 7" x 24" slip connector. The slip connector is identified by 3 holes at the top of the pipe. The slip connector has one flair at the top with the 3 holes. The bottom is smooth. The damper section and intermediate pipe section have flairings at both ends. The male end is always at the bottom.

Simpson Dura-Vent Chimney System

It is required to use a Dura-Vent Universal Connector part number 8874 to install the chimney connector.

1. The universal connector is installed into the support box. The 7" x 24" slip pipe is then connected to the universal connector.
2. The 7" x 24" intermediate pipe section is then slid over the slip connector pipe. Slide the 24 inch pipe over the slip pipe only far enough as necessary to facilitate installation of the 7" x 24" damper pipe in to the unit.
3. Slide the 7" x 24" pipe down onto the damper pipe installed on the Zircon.
4. There must be a minimum of 2 inches of overlap between the 7" x 24" and 7" x 24" slip connector pipe.

Metalbestos or Security

When using Metalbestos or Security chimney systems it is required to use the Metalbestos DS-CPA Single Wall Conector pipe. Security users must use the UP adapter.

1. Installation of the Metalbestos DS-CPA or the Security UP adapter must be done first.
2. Attach the 7" x 24" slip connector to the DS-CPA or UP adapter with 3 - #8 x 3/8 inch screws.
3. The 7" x 24" pipe section is then slid into the slip connector pipe. Slide the 24 inch pipe into the slip pipe only far enough as necessary to facilitate installation of the 7" x 24" damper pipe into the unit.
4. Slide the 7" x 24" pipe down onto the piece installed on the Zircon.
5. There must be a minimum of 2 inches of overlap between the 7" x 24" and 7" x 24" slip connector pipe.

Other Chimney Systems

There are many other manufacturer's of chimney systems. It is beyond the scope of this publication to cover installation with all of the different systems available. Most systems have a method of connection to the Zircon's connector pipe. Confirm installation procedures with your dealer or the manufacturer of the chimney system you have purchased.

Masonry Chimney

If using a masonry chimney, it must meet the minimum standards of the National Fire Protection Association (NFPA) Standard 211. The chimney must have at least a 5/8" fire clay liner or a listed chimney liner system. The chimney must be inspected for cracks, loose mortar, or any other signs of deterioration. It is best to have the chimney inspected by a professional. Make certain the chimney is cleaned prior to installation of this fireplace.

The size of the chimney should be between 36 and 96 square inches. Larger chimneys should be relined to meet these requirements. Incorrect sizing of the chimney may affect the draft and result in poor fireplace performance. Do not install more than one appliance to any chimney.

There are different accepted methods of connecting the fireplace to a masonry chimney through a combustible wall. This type of installation requires the use of a thimble to protect the surrounding combustible materials. Check with your local building officials or consult NFPA211. See Figure 4, Page 5.

Chimney Connector Instructions

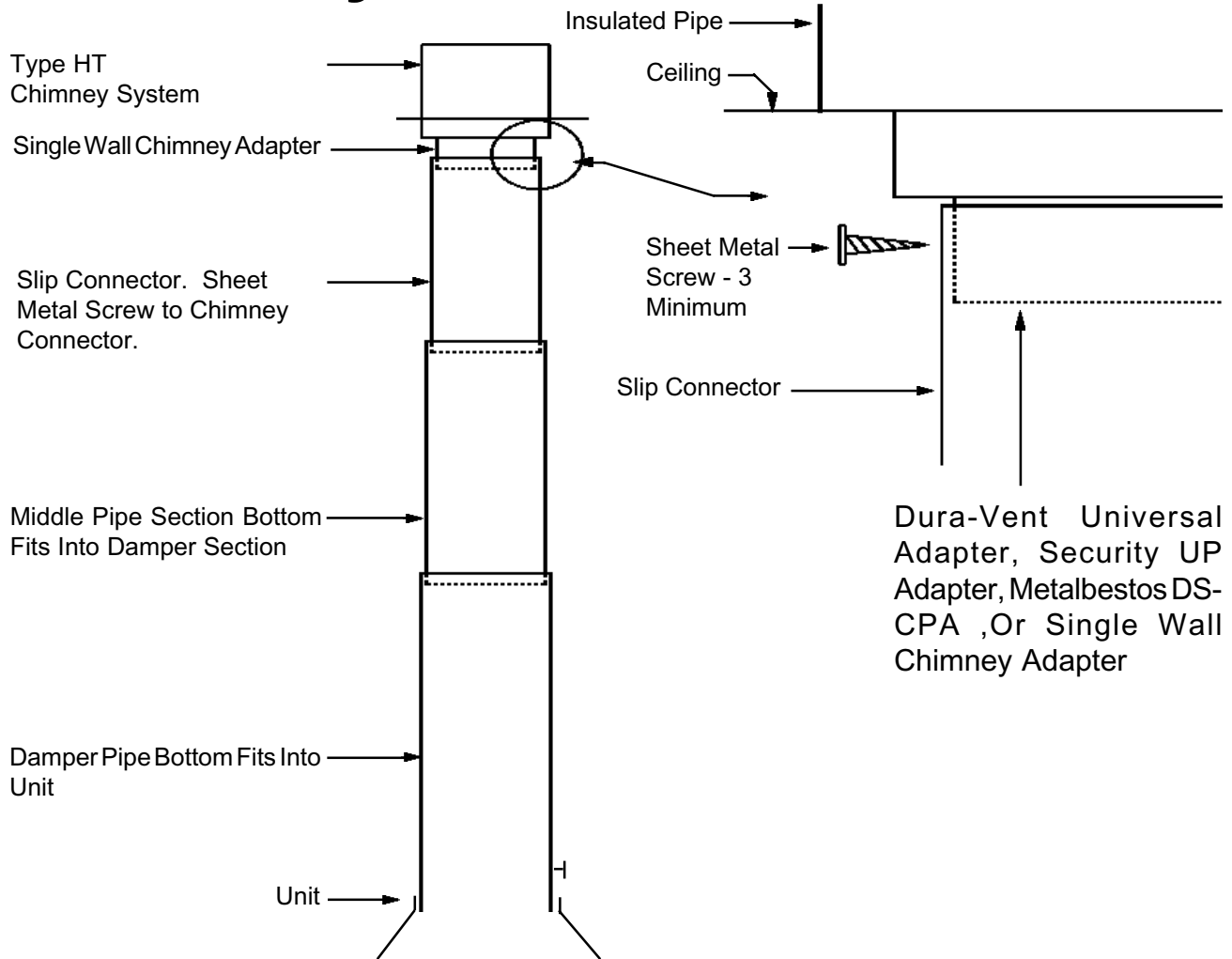

The above illustration represents the installation procedure for dripless pipe installation. This installation method of installing the connector pipe with the male end down allows for any moisture to remain on the inside of the connector pipe.

At first glance you may become concerned that smoke will escape the pipe and enter the room. This is not how the system will work. The vacuum in the chimney system will always pull air into the chimney. If you experience a downdraft with your installation it indicates that additional chimney height or a specialty draft cap be added to your chimney system. Contact your dealer for further information regarding downdrafts.

Attach and secure the chimney connector with a minimum of three screws to the Zircon and each adjoining section.

Material List

Included with the Zircon 34 is the following:

- 1 - 7 x 24 damper pipe
- 1 - 7 x 24 pipe section
- 1 - 7 x 24 slip section pipe
- 4 - 6lb bags of Malmcrete refractory.

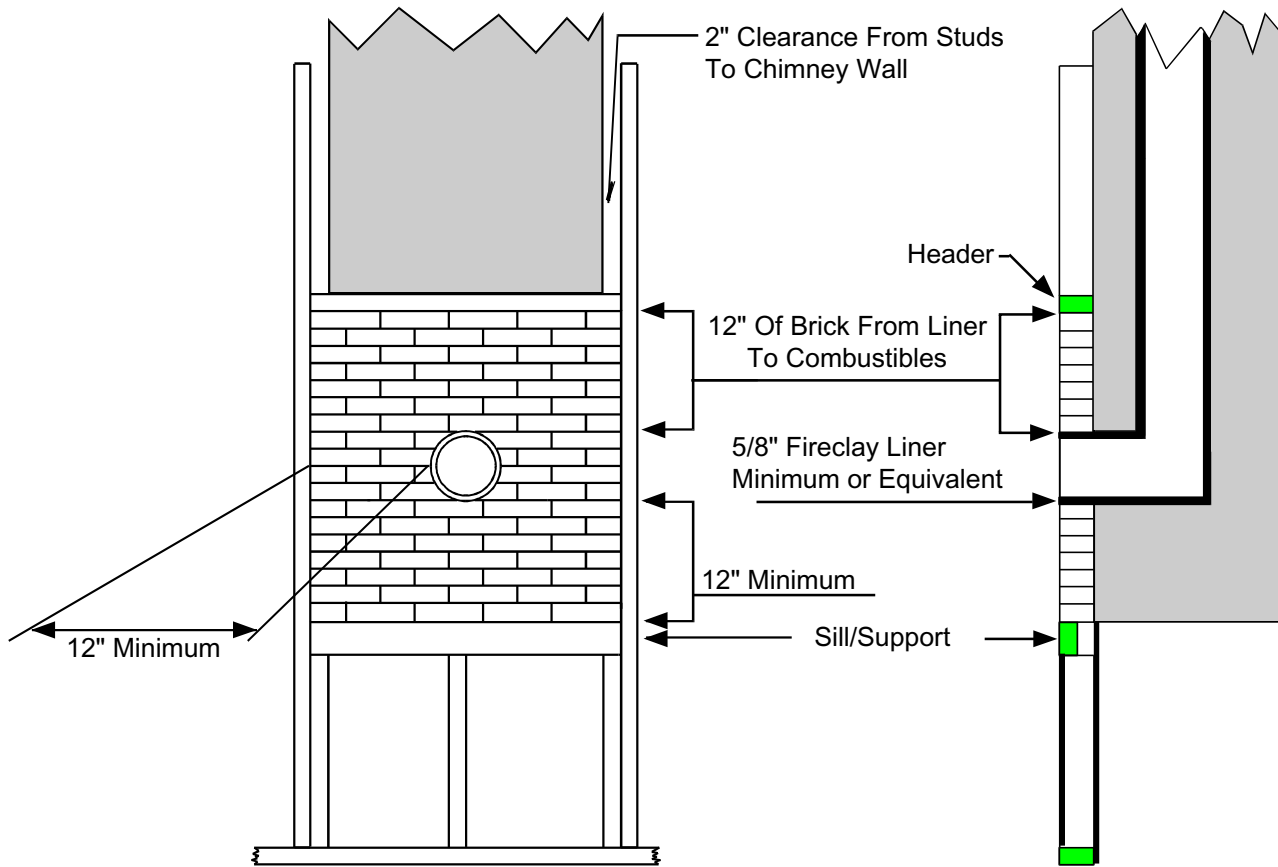

MASONRY THIMBLE
Figure 4

OPERATING INSTRUCTIONS

Failure to properly use and maintain this appliance may void the manufacturer's warranty and could result in a house fire.

CAUTION: HOT WHILE IN OPERATION. DO NOT TOUCH. KEEP CHILDREN, CLOTHING AND FURNITURE AWAY. CONTACT MAY CAUSE SKIN BURNS. SEE NAMEPLATE AND INSTRUCTIONS. Do Not over fire. If any portion of the unit or flue starts to glow you are over firing. This is a free standing fireplace, do not use for any other purpose.

1. The first few fires should be small in order to properly cure the painted surfaces and refractory. During the first few fires, some smoking may occur as the paint cures. You may wish to open a window to minimize discomfort during this curing period.
2. **DO NOT BURN TRASH OR GARBAGE IN THIS UNIT.** When building a fire, be sure the damper is fully opened and sufficient combustion air is available. Place dry kindling on dry wadded paper then ignite with a match. Add progressively larger pieces of wood until the fire is well established. Leave the damper fully open. Close only after the fire has burned out completely. Add additional firewood as needed to maintain the fire.
3. The fire screen must be in place during operations. **THIS FIREPLACE STOVE HAS NOT BEEN TESTED FOR USE WITH DOORS. TO REDUCE THE RISK OF FIRE OR INJURY, DO NOT INSTALL DOORS.**
4. **DO NOT USE A GRATE OR ELEVATE FIRE.** Build fire directly on Hearth.
5. Keep the pipe damper in the full open position when the fireplace is being used.
6. **CAUTION:** Heating the air in a closed building decreases the relative humidity of the air, which will dry wood and other combustible materials. This drying lowers the ignition temperature of these materials thus increasing fire hazards. To reduce the risk of fire, some provision should be made for replenishing moisture to the air whenever a structure is being heated for extended periods.
7. Be sure to provide combustion air into the dwelling when using this or any other wood burning appliance. A partially open window or outside air register in the vicinity of the unit would be acceptable. Combustion air must be supplied in conformance with the Uniform Mechanical Code.
8. **CAUTION: NEVER USE GASOLINE, GASOLINE TYPE LANTERN FUEL, KEROSENE, CHARCOAL LIGHTER FLUID, OR SIMILAR LIQUIDS TO START OR "FRESHEN UP" A FIRE IN THIS HEATER. KEEP ALL SUCH LIQUIDS WELL AWAY FROM THE HEATER WHILE IN USE.**
9. **DISPOSAL OF ASHES:** Ashes should be placed in a metal container with a tight fitting lid. The closed container of ashes should be placed on a noncombustible floor or on the ground, well away from all combustible materials, pending final disposal. If the ashes are to be disposed of by burial in soil or otherwise locally dispersed, they should be retained in the closed container until all cinders have thoroughly cooled.
10. **READ MAINTENANCE INSTRUCTIONS.**

IN CASE OF A CHIMNEY FIRE

A safe and correct installation and extra care will help prevent a fire, but accept the idea that there could be a fire. Be prepared to handle it. Make certain everyone in the house is familiar with the warning signs of a chimney fire:

1. Call the Fire Department immediately, before doing anything else.
2. Discharge a dry chemical extinguisher into the fireplace opening. If an extinguisher is not available, toss baking soda into the opening. Do not pour water on the fire.
3. Close all air intakes to the firebox and leave closed until the fireplace, stove or stove pipe is completely cooled.
4. Watch for sparks on the roof. If necessary, hose down the roof around the chimney. **DO NOT** pour water down or on the chimney.
5. After the fire is completely out, inspect the chimney for any signs of damage. If you are not certain, have your local Fire Department inspect the chimney for you. Never use a flammable liquid to kindle or rekindle a fire.
6. Never use coal in a fireplace. Coal should be used only in stoves especially designed to burn coal. If the toxic gases produced enter the room they can be fatal.

MAINTENANCE INSTRUCTIONS

Failure to properly use and maintain this appliance may void the manufacturer's warranty and could result in a house fire.

1. Always keep the area around the unit clean and clear of furniture and other objects. Keep all furniture a minimum of 48 inches away from the heater.
2. Periodically the entire unit, chimney connector, and chimney system must be inspected for leaks, broken or malfunctioning parts, and loose connections. If any problems are noted, contact your dealer for repair services. Do not operate the unit until repairs have been completed.

INSPECT AND CLEAN CHIMNEY FREQUENTLY - UNDER CERTAIN CONDITIONS OF USE, CREOSOTE BUILDUP MAY OCCUR RAPIDLY.

CREOSOTE FORMATION AND THE NEED FOR REMOVAL.

When wood is burned slowly, it produces tar and other vapors, which combine with moisture to form creosote. Creosote vapors condense in the relatively cool chimney flue, and creosote residue accumulates on the flue lining. When ignited, this creosote can make an extremely hot fire. The chimney connector and chimney should be inspected at least twice monthly during the heating season to determine if creosote buildup has occurred. If creosote has accumulated, it should be removed to reduce the chance of a chimney fire.

HOW TO REMOVE CREOSOTE.

1. Clean the chimney with brushes and equipment available at local fireplace shops.
2. Chemical chimney cleaners are used by adding them to the fire, but they are not intended for use in chimneys already containing heavy soot deposits. Rather, they are intended to inhibit soot buildup. They can be used in metal chimneys provided the manufacturers instructions are strictly followed. Generally these commercial cleaners are quite effective.
3. Call a professional chimney sweep in your area. They possess the experience and tools necessary to make the task easy.

Maintenance other than the items specifically mentioned herein are to be performed by a qualified serviceman only. Contact your dealer. For further information on using your heater safely, obtain a copy of the National Fire Protection Association publication "Using Coal and Wood Stoves Safely," NFPA HS-10-1978. The address of the NFPA is Batterymarch Park, Quincy, MA 02269. File these instructions for future reference.

NEVER STORE OR ALLOW PAPERS, KINDLING, FIREWOOD OR ANY OTHER COMBUSTIBLES WITHIN 48 INCHES OF UNIT.

 **Malm Fireplaces, Inc.**

368 Yolanda Avenue
Santa Rosa, Ca 95404

(707) 523-7755 - (800) 535-8955

Fax: (707) 571-8036

On the web! www.malmfireplaces.com

info@malmfireplaces.com



COMPANY

Johns Manville, a Berkshire Hathaway company, was founded in 1858. Our ownership by Berkshire Hathaway, one of the most admired companies in the world and one of the most financially secure, allows JM to invest for the future. This enables JM to continue delivering the broadest range of insulation products in the industry and offering innovative solutions that meet your needs.

DESCRIPTION

JM Formaldehyde-free™ thermal and acoustical insulation is made of long, resilient glass fibers bonded with a thermosetting resin. A wide range of thermal resistance R-values is available to provide thermal control for both vertical and horizontal applications. JM insulation is available unfaced or with a variety of facings, including kraft or foil vapor retarder.

USE

JM Formaldehyde-free™ thermal and acoustical insulation can be used in a wide variety of wood frame, engineered wood and steel frame construction applications, including:

New Construction: residential homes and commercial buildings interior and exterior walls, floors and ceilings for thermal and sound control, as well as basement wall insulation.

Retrofit: adding insulation to attics, crawl spaces and above suspended ceilings.

INSTALLATION

JM insulation cuts easily with an ordinary utility knife, and unfaced or tabless versions install easily by simply pressing in place between studs or joists in standard framing. Standard facings have stapling tabs for attachment to framing if additional securement is required.

PACKAGING

JM insulation is compression-packaged for savings in storage and freight costs.

DESIGN CONSIDERATIONS

Kraft and standard foil facings on this product will burn and must not be left exposed. It must be covered with gypsum board or another approved interior finish. Where an exposed application is required, use FSK-25 flame-resistant faced insulation.

In colder climate areas, vapor retarders (whether attached to the insulation or applied separately) are often placed toward the heated or conditioned side of the wall. This is done to reduce water vapor penetration into the wall from the building interior. Check your local building codes for vapor retarder requirements.

Refer to JM guide specifications for further design considerations and required installation instructions.

LIMITATIONS OF USE

Check applicable building codes.



Actual color of product may be lighter than image.
Product image typical of material produced in the USA.

PERFORMANCE ADVANTAGES

Formaldehyde-free: will not off-gas formaldehyde in the indoor environment.

Thermally Efficient: provides effective resistance to heat transfer with R-values up to R-49 (RSI-8.6).

Sound Control: reduces transmission of sound through exterior and interior walls and floor or ceiling assemblies.

Fire Resistant and Noncombustible: see Physical Properties.

Durable Inorganic Glass: will not rot, mildew or deteriorate and is noncorrosive to pipes, wiring and metal studs.

Superior Performance: bonded glass fibers are dimensionally stable and will not slump within the wall cavity, settle or break down during normal applications.

ENERGY AND ENVIRONMENT



*GREENGUARD certification is not intended for residential environments. Instead, the certification is intended only for buildings meeting ASHRAE 62.1-2007 commercial building ventilation rates. This certification is proof that the product meets the GREENGUARD Environmental Institute's indoor air quality standards and product emission standards for VOCs.

APPLICABLE STANDARDS & BUILDING CODE CLASSIFICATION*

JM UNFACED INSULATION	JM KRAFT FACED INSULATION	JM FOIL FACED INSULATION
ASTM C665, Type I; ASTM E136	ASTM C665, Type II Class C, Category 1	ASTM C665, Type III, Class B, Category 1
IBC, ALL TYPES	IBC TYPES III, IV, V	IBC TYPES III, IV, V

* JM Insulation complies with IBC (International Building Code), model code requirements for building construction types listed above.

STANDARD SIZES**

R-VALUE (hr·ft ² ·°F/Btu)	RSI VALUE (m ² ·°C/Watts)	THICKNESS**		WIDTH†		
		in (mm)		METAL FRAMING in (mm)		WOOD FRAMING in (mm)
††	††	2¾ (70)		16 (406)	24 (610)	—
11	1.9	3½ (89)	3¾ (92)	16 (406)	24 (610)	15 (381) 19 (483) 23 (584)
13	2.3	3½ (89)	3¾ (92)	16 (406)	24 (610)	15 (381) 23 (584)
15	2.6	3½ (89)		—	—	15 (381)
19	3.3	6½ (165)		16 (406)	24 (610)	15 (381) 19 (483) 23 (584)
20	3.5	5½ (140)		—	—	15 (381)
21	3.7	5½ (140)		16 (406)	—	15 (381) 23 (584)
22	3.9	7½ (191)		—	—	15 (381)
30	5.3	10¾ (260)		16 (406)	24 (610)	16 (406) 19 (483) 24 (610)
30†	5.3	8¾ (210)		—	—	15½ (394) 23¾ (600)
38	6.7	13 (330)		16 (406)	24 (610)	16 (406) 24 (610)
38†	6.7	10¾ (260)		—	—	15½ (394) 23¾ (600)
49	8.6	13½ (343)		16 (406)	24 (610)	16 (406) 24 (610)

** Consult your local JM sales representative or product availability chart for available sizes and R-values (RSI-values) including wide-roll products.

*** Thickness may vary by producing location.

† Special widths and lengths may be available. Check with your local JM sales representative. Standard product lengths include 48", 93" and 96" (1219 mm, 2362 mm and 2438 mm) batts.

†† For sound control applications in interior walls.

‡ Cathedral ceiling application.

PHYSICAL PROPERTIES**

PRODUCTION	FLAME SPREAD	SMOKE DEVELOPED	VAPOR RETARDER (PERMS)	WATER VAPOR SORPTION	DIMENSIONAL STABILITY
Unfaced	<25	<50	N/A	<5%	Less than 0.1%
Foil Faced	<75	<150	0.05	N/A	Less than 0.1%
Kraft Faced	N/R	N/R	1	N/A	Less than 0.1%

‡‡ Products are tested in accordance: R-value ASTM C518 | Surface Burning Characteristics ASTM E84 | Perm Rating ASTM E96 | Water Vapor Sorption ASTM C1104

Kraft and standard foil facing will burn. Do not leave exposed. Facing must be installed in substantial contact with an approved ceiling, floor or wall material. Keep open flame and other heat sources away from facing. Do not place insulation within 3" of light fixtures or similar electrical devices unless device is labeled for contact with insulation. Use only unfaced insulation between wood framing and masonry chimneys. Do not use insulation in spaces around metal chimneys, fireplaces, or flues. JM Unfaced insulation is considered non-combustible by model building codes. Flame Spread 25 products are flame spread rated and can be left exposed where codes allow. See package for warnings, fire hazard and installation instructions, or call 800-654-3103.

Due to potential skin irritation, unfaced insulation should not be used for exposed applications where it will be subject to human contact.

MEETS CLASS II VAPOR RETARDER REQUIREMENT FOR UNVENTED ATTIC.