

VILLAGE NEST EAST PRUD

SITE CONSTRUCTION DRAWINGS

Located in Sec 08 T7N R2E
Weber County, Utah

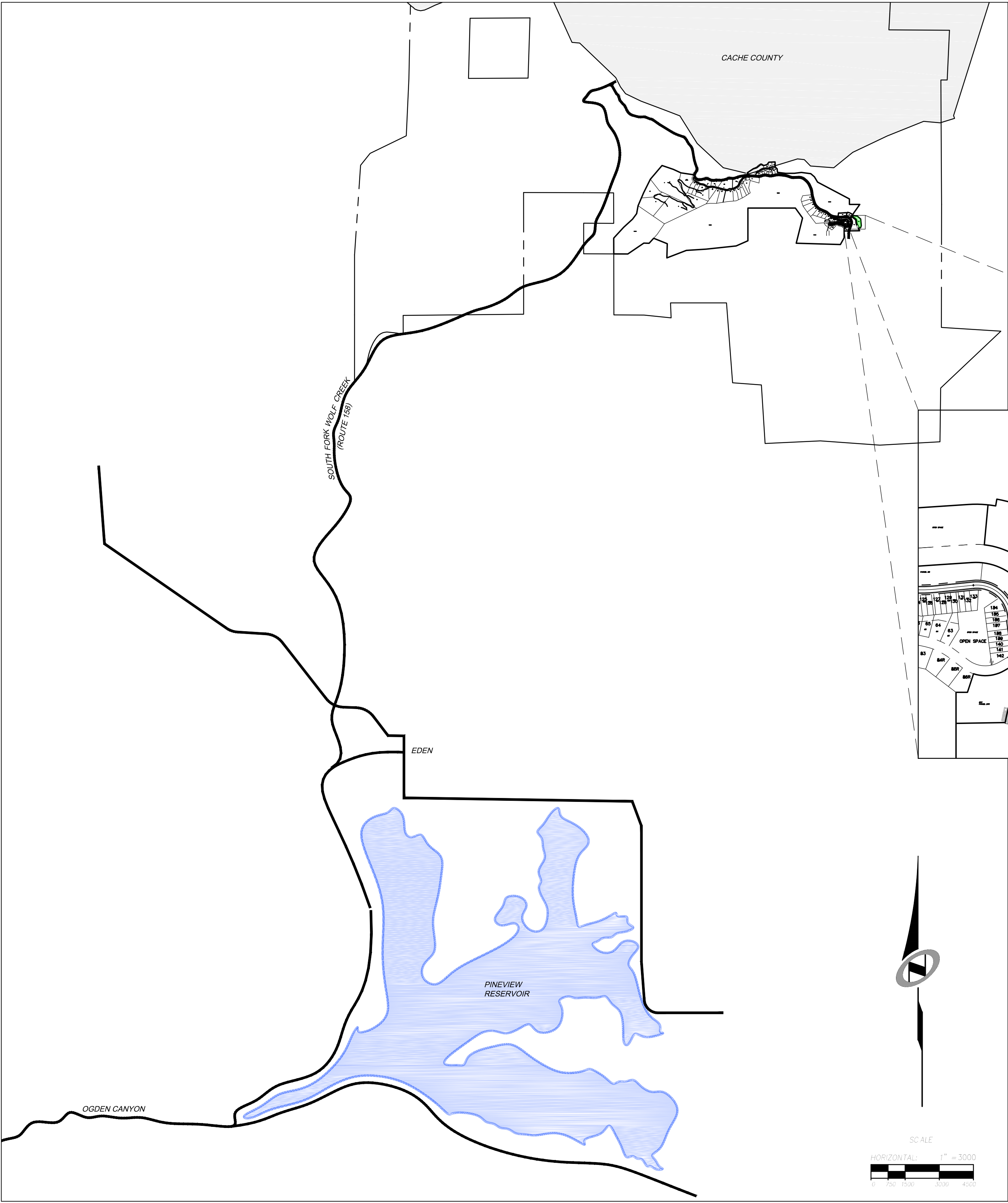

SHEET INDEX:

SHEET NO.	SHEET DESCRIPTION
1	1.00 CIVIL TITLE SHEET
2	1.01 GENERAL NOTES
3	1.02 DEMOLITION PLAN
4	1.03 OVERALL UTILITY PLAN
5	1.04 SITE AND WET UTILITY PLAN
6	1.05 PLAN AND PROFILE
7	1.06 PLAN AND PROFILE
8	1.07 PLAN AND PROFILE
9	1.08 DRY UTILITY PLAN
10	1.09 GRADING PLAN
11	4.00 EROSION CONTROL PLAN
12	4.01 EROSION CONTROL DETAILS
13	5.00 DETAILS
14	5.01 DETAILS
15	5.02 DETAILS
16	5.03 DETAILS

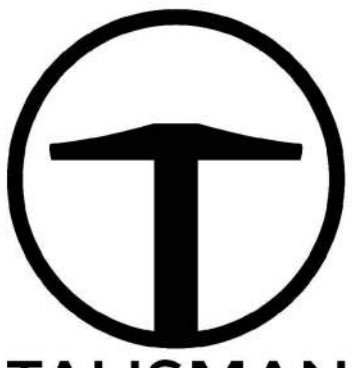

TALISMAN
CIVIL CONSULTANTS
6217 SOUTH STATE STREET
SUITE 200
MURRAY, UT 84107
801.743.1300

NO.	BY	DATE	REVISIONS

VILLAGE NEST EAST PRUD
SITE CONSTRUCTION DRAWINGS
CIVIL TITLE SHEET

TCC JOB NUMBER: 17-200.08
DATE SUBMITTED: 06.15.2017

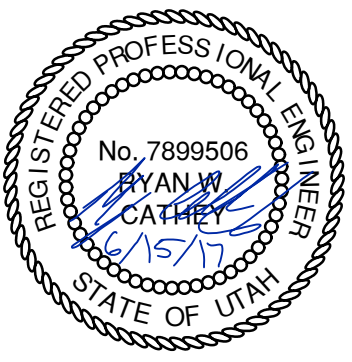

SHEET NUMBER

1.00

DATE: 5/03/17

PATH: N:\SIBD793\Cad\ Village_Nest_VP1000.dwg



DATE: 5/03/17

PATH: N:\SIBD793\Cad\Village_Nest_VP102_DM.dwg



KEY NOTES

- ① FUTURE CURB AND GUTTER LAYOUT. SEE PHASE 1D PLANS.
- ② REMOVE AND PROPERLY DISPOSE OF EXISTING SEWER MANHOLE.
- ③ REMOVE AND PROPERLY DISPOSE OF EXISTING SEWER PIPE.
- ④ REMOVE AND PROPERLY DISPOSE OF EXISTING STORM DRAIN PIPE.
- ⑤ REMOVE AND RELOCATE EXISTING PRESSURE RELEASE VALVE. SEE SITE AND UTILITY PLAN FOR NEW LOCATION.
- ⑥ PROTECT IN PLACE EXISTING UTILITY LINES AND STRUCTURES.

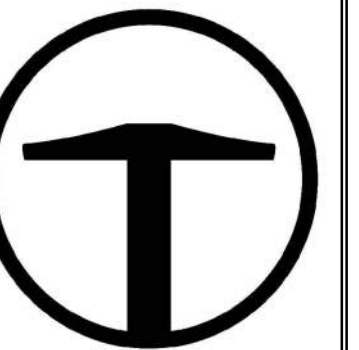

TALISMAN
 CIVIL CONSULTANTS
 6217 SOUTH STATE STREET
 SUITE 200
 MURRAY, UT 84107
 801.743.1300

NO.	BY	DATE	REVISIONS

VILLAGE NEST EAST PRUD
 SITE CONSTRUCTION DRAWINGS
 DEMOLITION PLAN

DATE SUBMITTED: 06.15.2017

TCC JOB NUMBER: 17-200.08

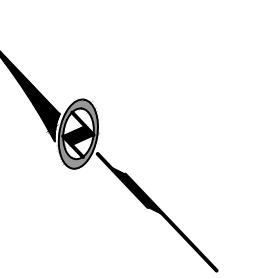
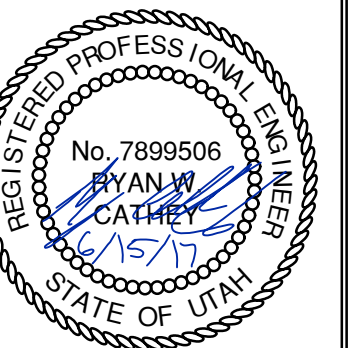

SCALE
 HORIZONTAL: 1" = 20'

SHEET NUMBER
1.02



DATE: 5/03/17

PATH: N:\SIBD793\Cad\ Village Nest\VP10301.dwg

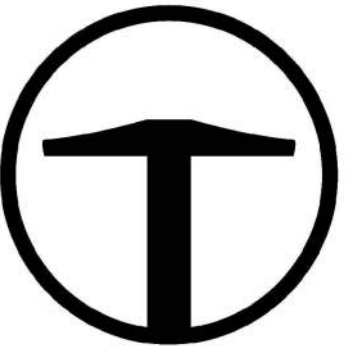
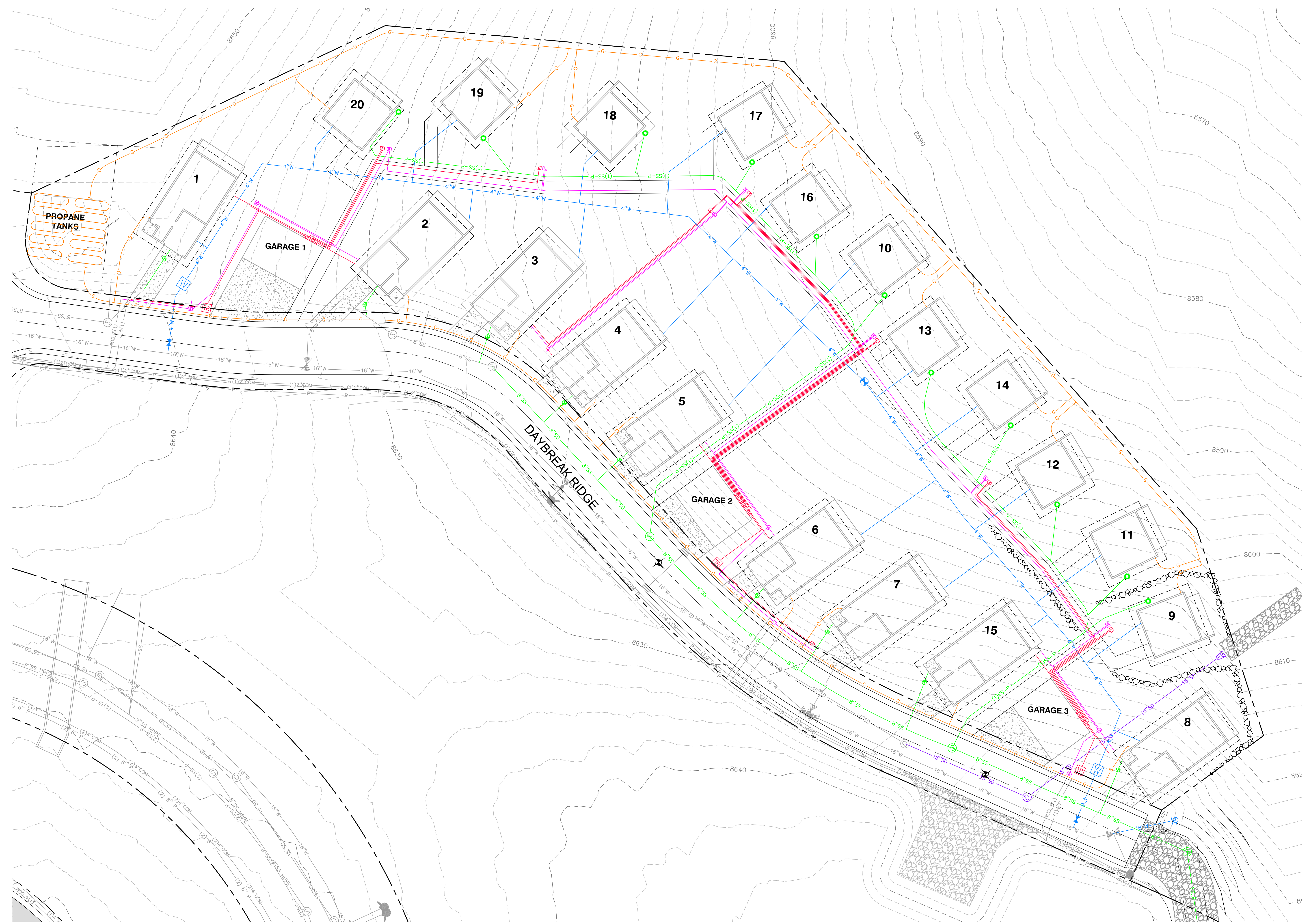

TALISMAN
 CIVIL CONSULTANTS
 6217 SOUTH STATE STREET
 SUITE 200
 MURRAY, UT 84107
 801.743.1300

NO.	BY	DATE	REVISIONS

VILLAGE NEST EAST PRUD
 SITE CONSTRUCTION DRAWINGS
 OVERALL UTILITY PLAN

DATE SUBMITTED: 06.15.2017

TCC JOB NUMBER: 17-200.08

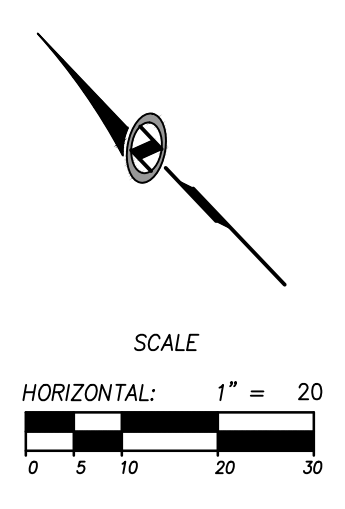
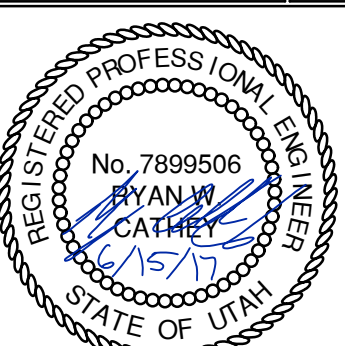

SHEET NUMBER
1.03



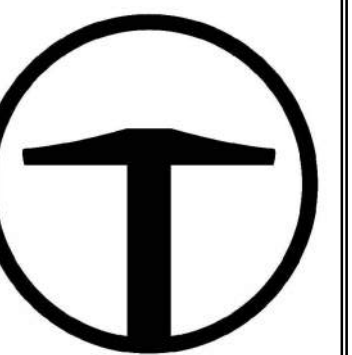

TALISMAN
CIVIL CONSULTANTS
5217 SOUTH STATE STREET
SUITE 200
MURRAY, UT 84107
801.743.1300

NO.	DATE	BY	REVISIONS

VILLAGE NEST EAST PRUD
SITE CONSTRUCTION DRAWINGS
SITE AND WET UTILITY PLAN

DATE SUBMITTED: 06.15.2017

TCC JOB NUMBER: 17-200.08

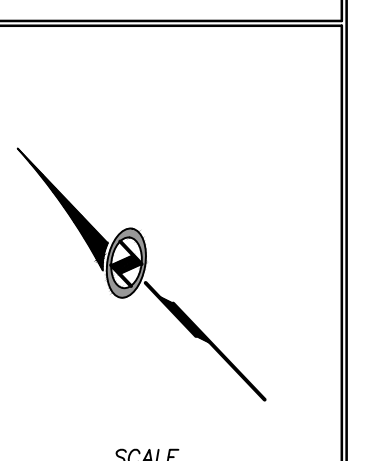
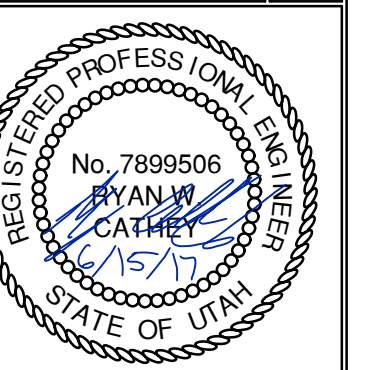

SCALE
HORIZONTAL: 1" = 20'

SHEET NUMBER
1.04



DATE: 5/03/17

PATH: N:\SLIBD793\Cadd\ Village_Nest_VP\10401.dwg

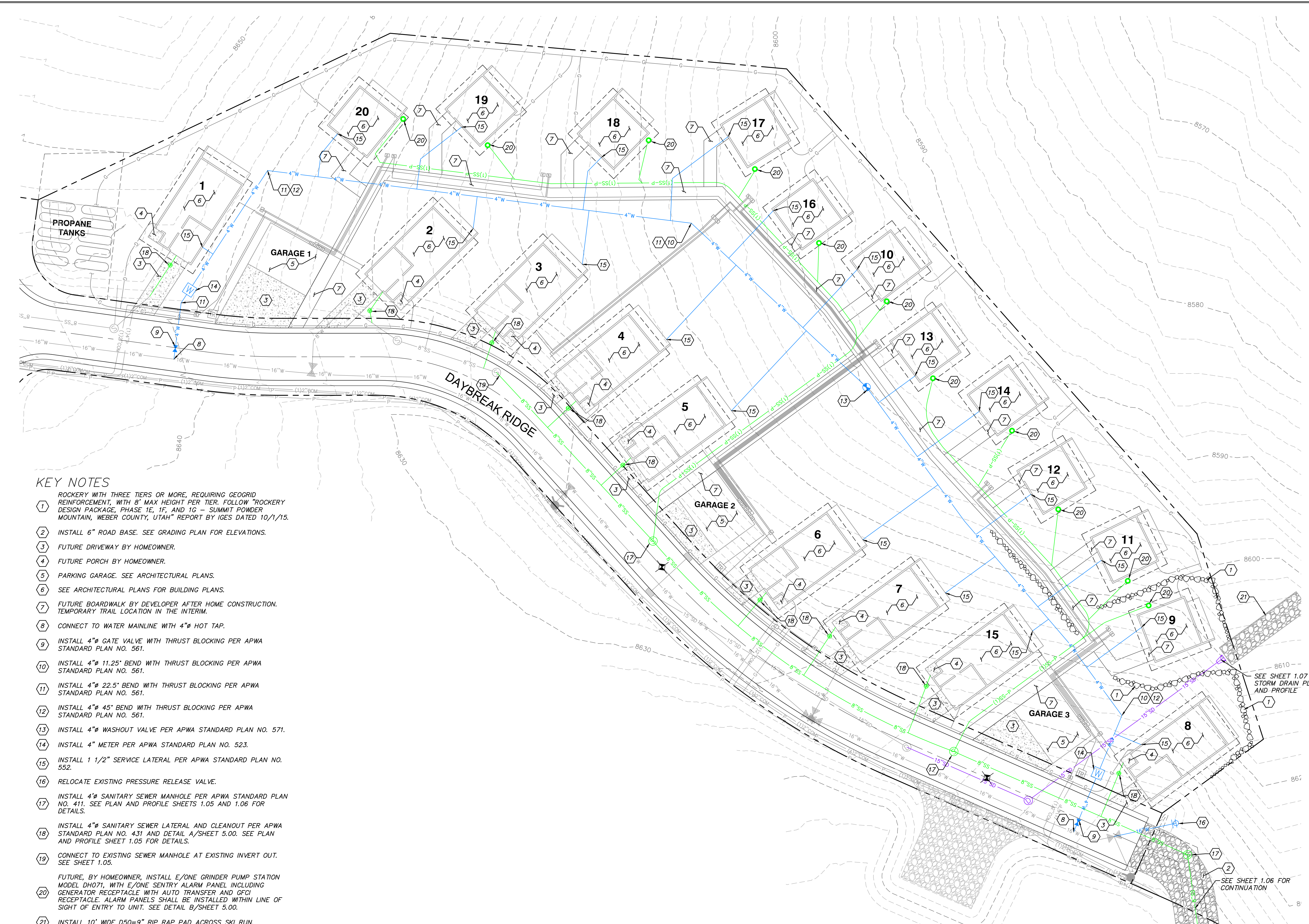

KEY NOTES

- 1 ROCKERY WITH THREE TIERS OR MORE, REQUIRING GEOGRID REINFORCEMENT, WITH 8" MAX HEIGHT PER TIER. FOLLOW "ROCKERY DESIGN PACKAGE, PHASE 1E, 1F, AND 1G - SUMMIT POWDER MOUNTAIN, WEBER COUNTY, UTAH" REPORT BY IGES DATED 10/1/15.
- 2 INSTALL 6" ROAD BASE. SEE GRADING PLAN FOR ELEVATIONS.
- 3 FUTURE DRIVEWAY BY HOMEOWNER.
- 4 FUTURE PORCH BY HOMEOWNER.
- 5 PARKING GARAGE. SEE ARCHITECTURAL PLANS.
- 6 SEE ARCHITECTURAL PLANS FOR BUILDING PLANS.
- 7 FUTURE BOARDWALK BY DEVELOPER AFTER HOME CONSTRUCTION. TEMPORARY TRAIL LOCATION IN THE INTERIM.
- 8 CONNECT TO WATER MAINLINE WITH 4" Ø HOT TAP.
- 9 INSTALL 4" Ø GATE VALVE WITH THRUST BLOCKING PER APWA STANDARD PLAN NO. 561.
- 10 INSTALL 4" Ø 11.25° BEND WITH THRUST BLOCKING PER APWA STANDARD PLAN NO. 561.
- 11 INSTALL 4" Ø 22.5° BEND WITH THRUST BLOCKING PER APWA STANDARD PLAN NO. 561.
- 12 INSTALL 4" Ø 45° BEND WITH THRUST BLOCKING PER APWA STANDARD PLAN NO. 561.
- 13 INSTALL 4" Ø WASHOUT VALVE PER APWA STANDARD PLAN NO. 571.
- 14 INSTALL 4" METER PER APWA STANDARD PLAN NO. 523.
- 15 INSTALL 1 1/2" SERVICE LATERAL PER APWA STANDARD PLAN NO. 552.
- 16 RELOCATE EXISTING PRESSURE RELEASE VALVE.
- 17 INSTALL 4" Ø SANITARY SEWER MANHOLE PER APWA STANDARD PLAN NO. 411. SEE PLAN AND PROFILE SHEETS 1.05 AND 1.06 FOR DETAILS.
- 18 INSTALL 4" Ø SANITARY SEWER LATERAL AND CLEANOUT PER APWA STANDARD PLAN NO. 431 AND DETAIL A/SHEET 5.00. SEE PLAN AND PROFILE SHEET 1.05 FOR DETAILS.
- 19 CONNECT TO EXISTING SEWER MANHOLE AT EXISTING INVERT OUT. SEE SHEET 1.05.
- 20 FUTURE, BY HOMEOWNER, INSTALL E/ONE GRINDER PUMP STATION MODEL DH071, WITH E/ONE SENTRY ALARM PANEL INCLUDING GENERATOR RECEPTACLE WITH AUTO TRANSFER AND GFCI RECEPTACLE. ALARM PANELS SHALL BE INSTALLED WITHIN LINE OF SIGHT OF ENTRY TO UNIT. SEE DETAIL B/SHEET 5.00.
- 21 INSTALL 10' WIDE D50=9" RIP RAP PAD ACROSS SKI RUN.

SEE SHEET 1.07 FOR STORM DRAIN PLAN AND PROFILE

SEE SHEET 1.06 FOR CONTINUATION

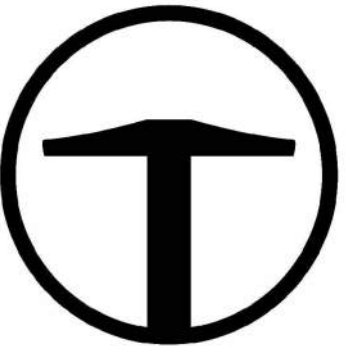

TALISMAN
 CIVIL CONSULTANTS
 5217 SOUTH STATE STREET
 SUITE 200
 MURRAY, UT 84107
 801.743.1300

NO.	DATE	BY	REVISIONS

VILLAGE NEST EAST PRUD
 SITE CONSTRUCTION DRAWINGS
 PLAN AND PROFILE

DATE SUBMITTED: 06.15.2017

TCC JOB NUMBER: 17-200.08

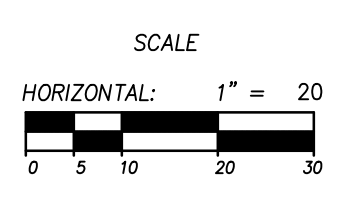
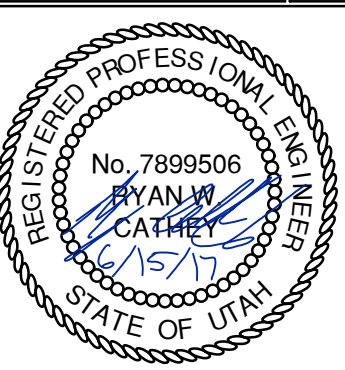

SHEET NUMBER
1.05

DATE: 5/03/17

PATH: N:\SIBD793\Coad_Village_Nest_VP105PP.dwg

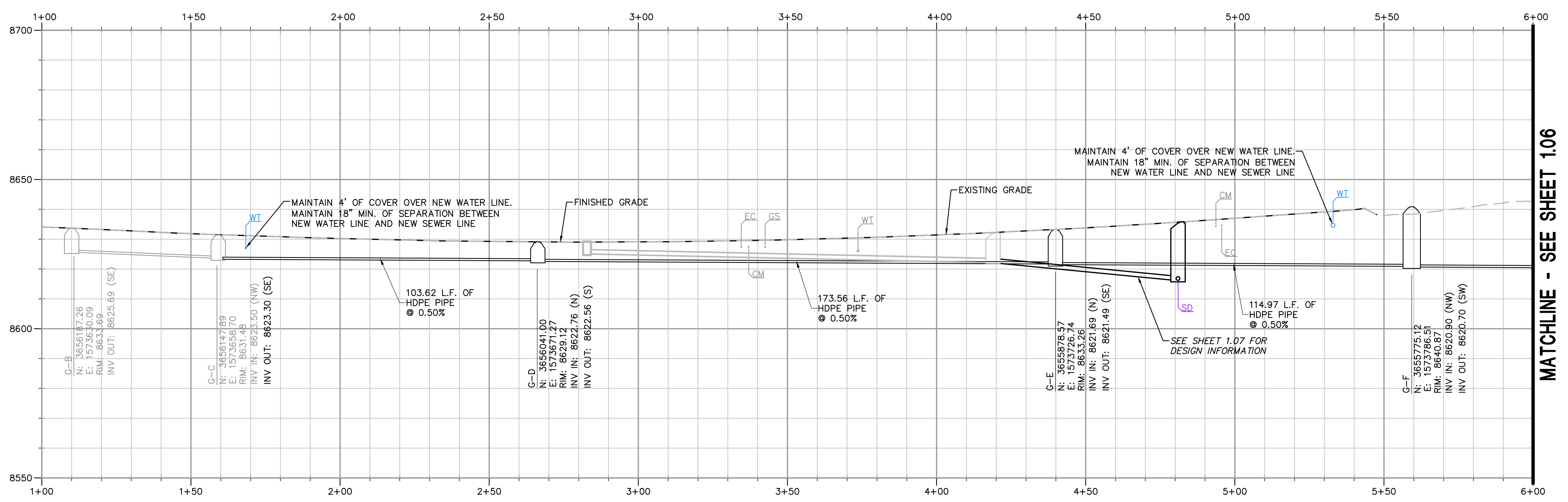
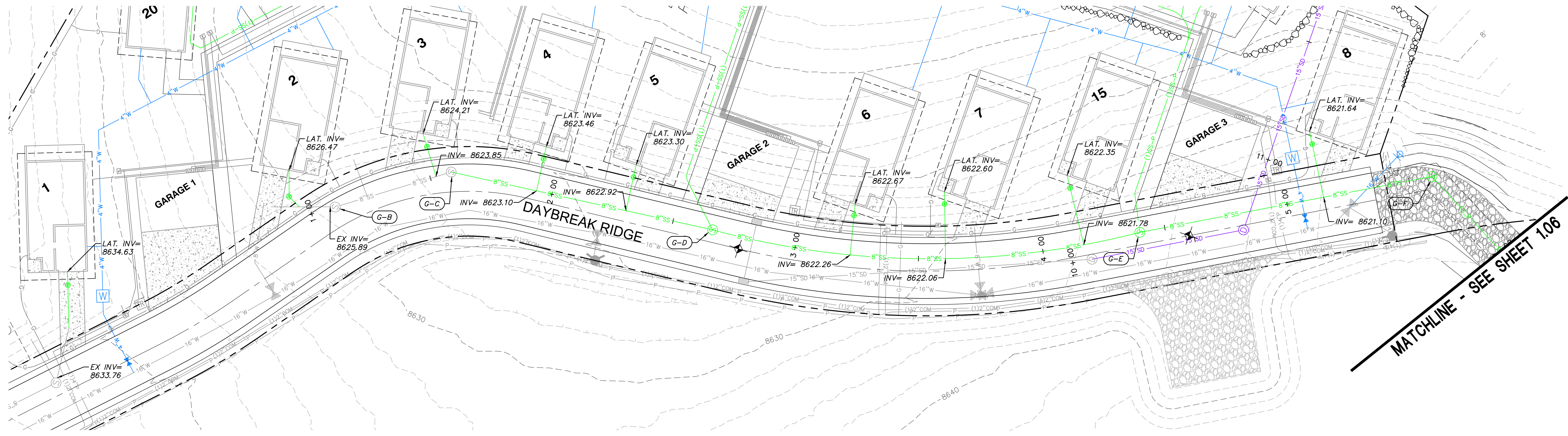

MATCHLINE - SEE SHEET 1.06



DATE: 5/03/17

PATH: N:\SIBD793\Cadd\ Village_Nest\VP_106PP.dwg

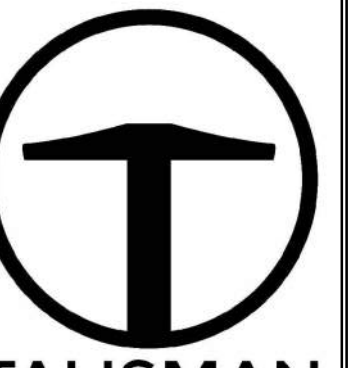

TALISMAN CIVIL CONSULTANTS
6217 SOUTH STATE STREET
SUITE 200
MURRAY, UT 84107
801.743.1300

NO.	BY	DATE	REVISIONS

VILLAGE NEST EAST PRUD
SITE CONSTRUCTION DRAWINGS
PLAN AND PROFILE

TCC JOB NUMBER: 17-200.08 DATE SUBMITTED: 06.15.2017

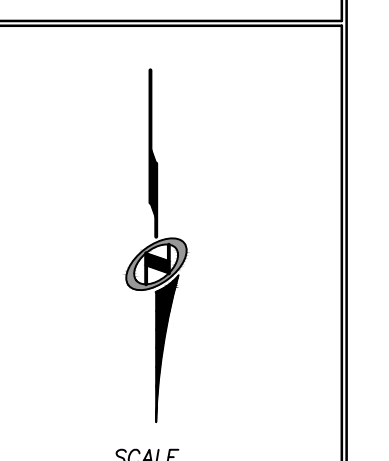
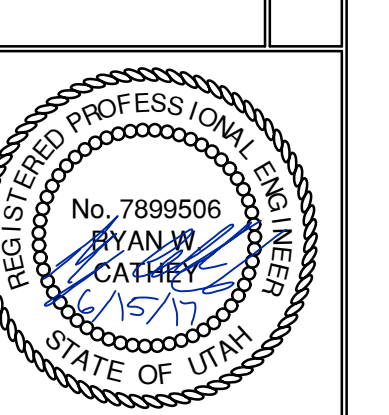

SCALE
HORIZONTAL: 1" = 20'

SHEET NUMBER
1.06

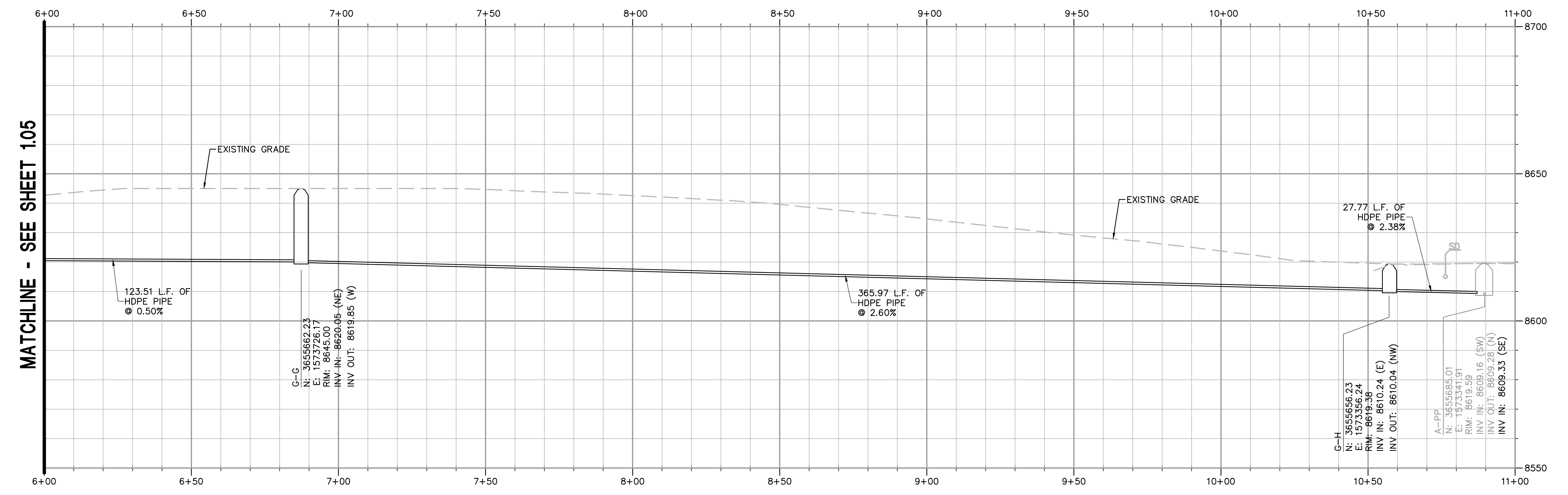
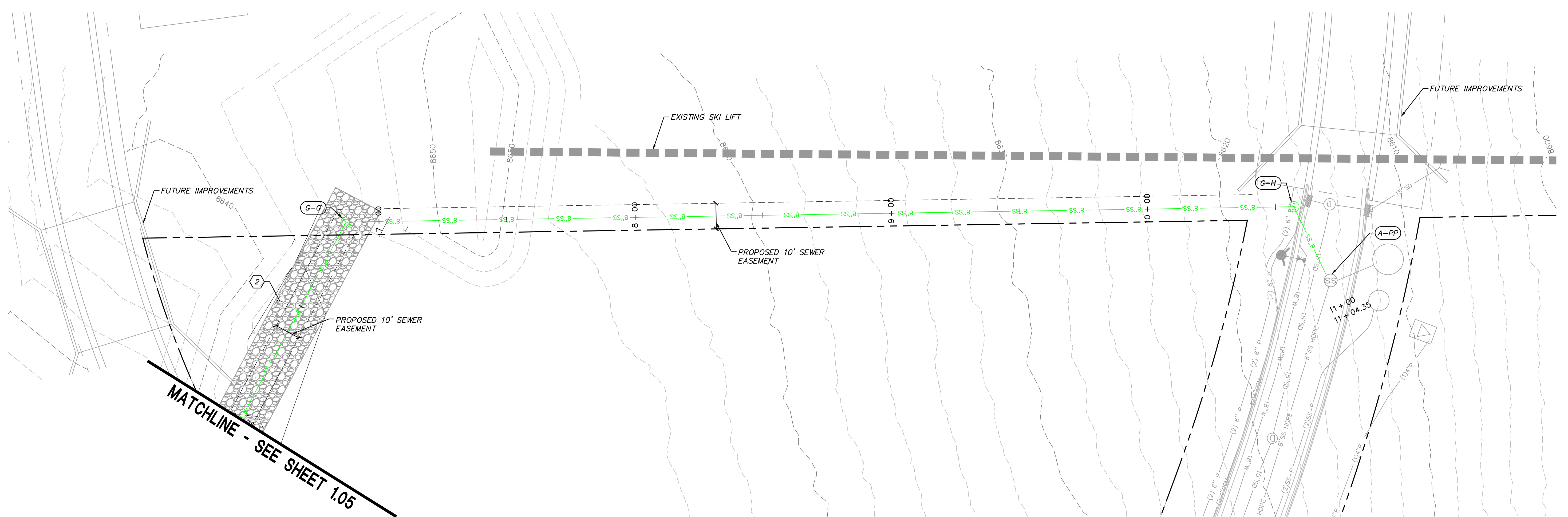

MATCHLINE - SEE SHEET 1.05

6+00 6+50 7+00 7+50 8+00 8+50 9+00 9+50 10+00 10+50 11+00

8700
8650
8600
8550

EXISTING GRADE

EXISTING GRADE

123.51 L.F. OF HDPE PIPE @ 0.50%

365.97 L.F. OF HDPE PIPE @ 2.60%

27.77 L.F. OF HDPE PIPE @ 2.38%

G-G
N: 3655662.23
E: 1573726.17
RIM: 8645.00
INV IN: 8620.05 (NE)
INV OUT: 8619.85 (W)

G-H
N: 3655656.23
E: 1573356.24
RIM: 8619.36
INV IN: 8610.24 (E)
INV OUT: 8610.04 (NW)

A-PP
N: 3655685.01
E: 1573341.91
RIM: 8619.59
INV IN: 8609.16 (SW)
INV OUT: 8609.28 (N)
INV IN: 8609.33 (SE)

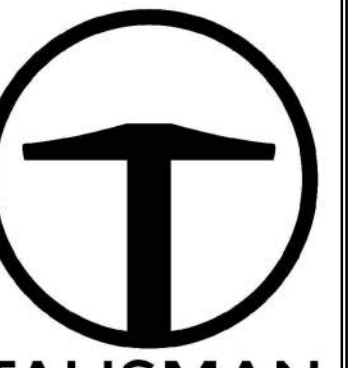
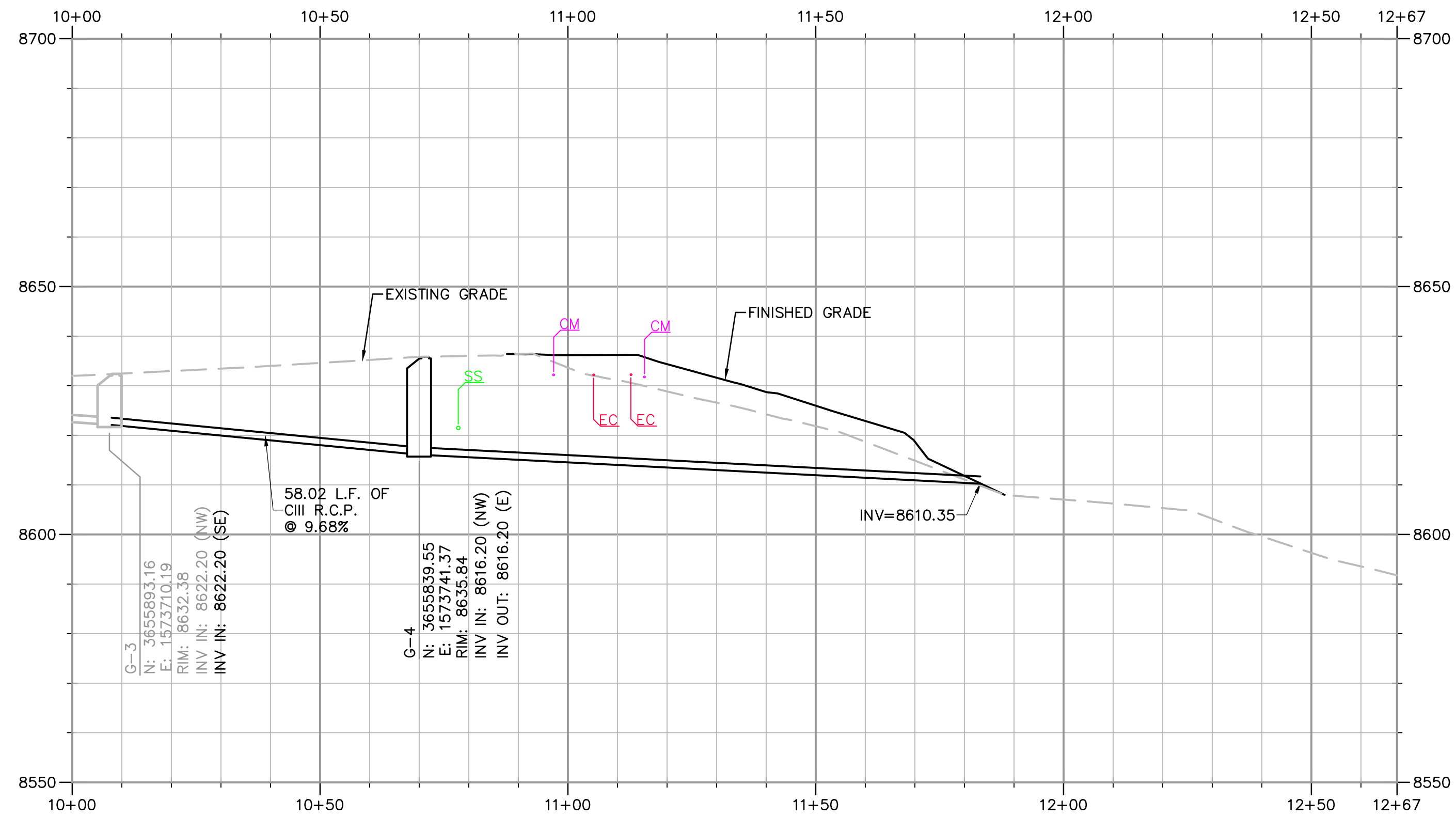
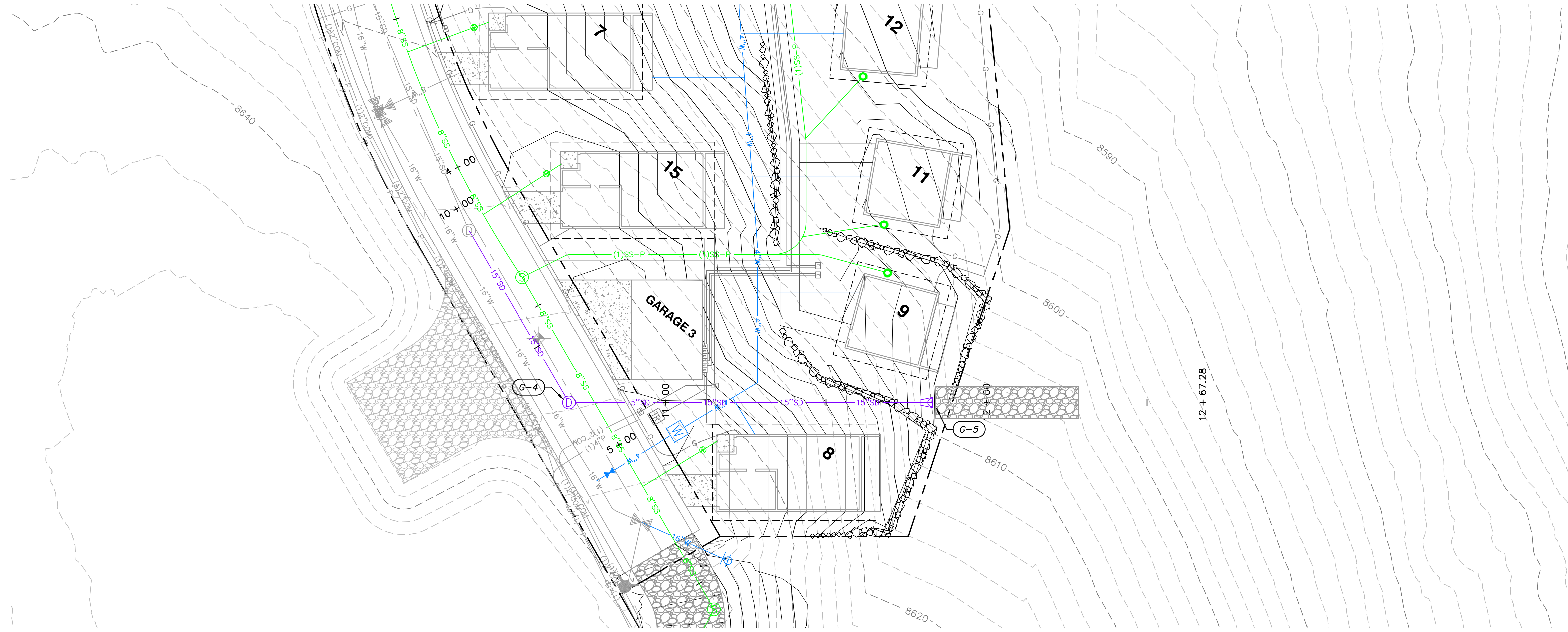

TALISMAN
 CIVIL CONSULTANTS
 6217 SOUTH STATE STREET
 SUITE 200
 MURRAY, UT 84107
 801.743.1300

NO.	BY	DATE	REVISIONS

VILLAGE NEST EAST PRUD
 SITE CONSTRUCTION DRAWINGS
 PLAN AND PROFILE

DATE SUBMITTED: 06.15.2017

TCC JOB NUMBER: 17-200.08

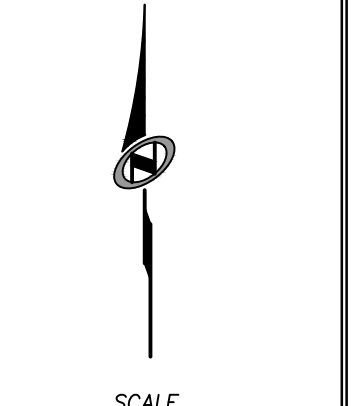
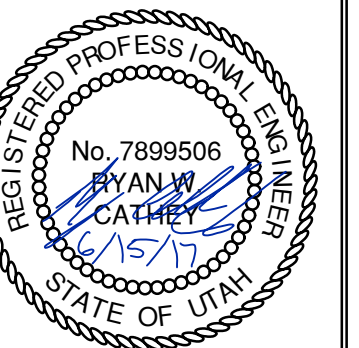

SCALE
 HORIZONTAL: 1" = 20'

SHEET NUMBER
1.07



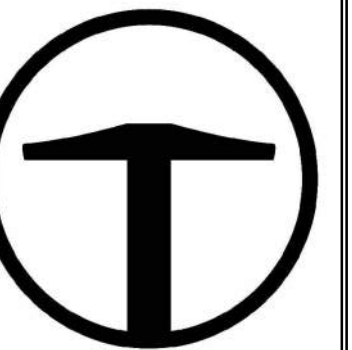

TALISMAN
 CIVIL CONSULTANTS
 6217 SOUTH STATE STREET
 SUITE 200
 MURRAY, UT 84107
 801.743.1300

NO.	BY	DATE	REVISIONS

VILLAGE NEST EAST PRUD
 SITE CONSTRUCTION DRAWINGS
 DRY UTILITY PLAN

DATE SUBMITTED: 06.15.2017

TCC JOB NUMBER: 17-200.08

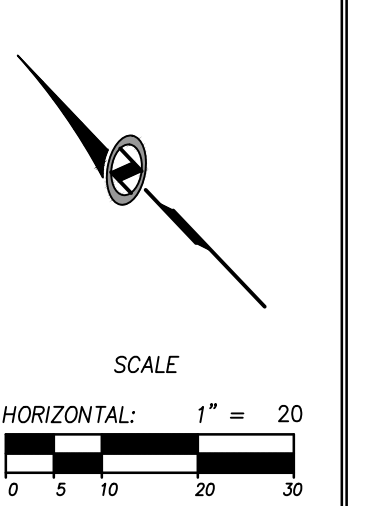
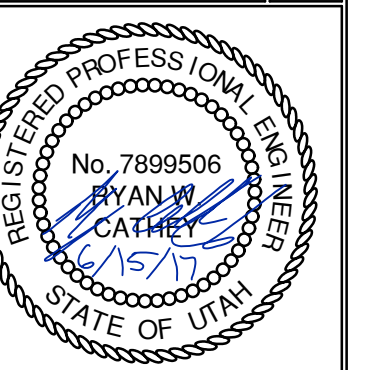

SHEET NUMBER
1.08

DATE: 5/03/17

PATH: N:\SIBD793\Cad\ Village Nest\VP108801.dwg

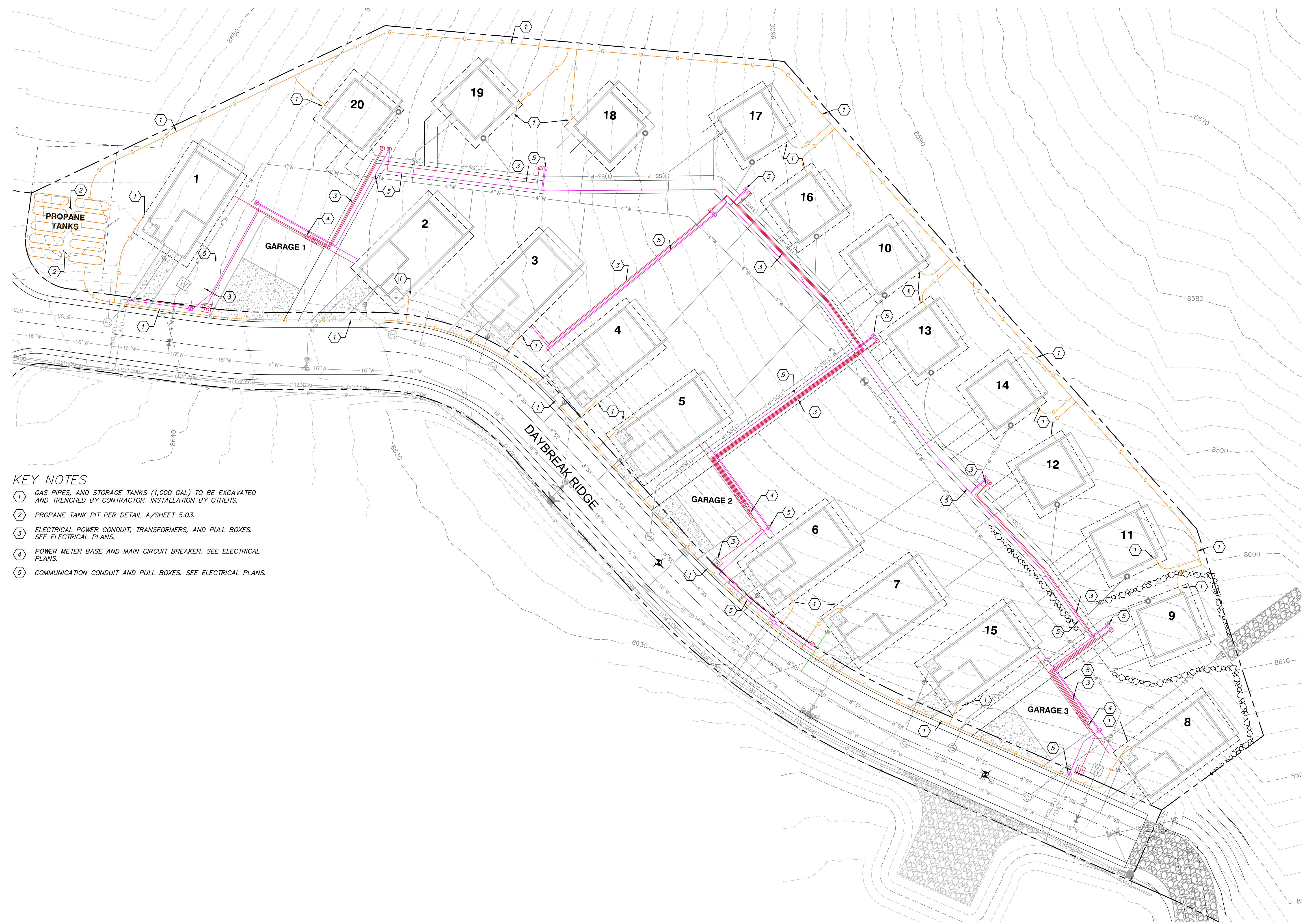

KEY NOTES

- 1 GAS PIPES, AND STORAGE TANKS (1,000 GAL) TO BE EXCAVATED AND TRENCHED BY CONTRACTOR. INSTALLATION BY OTHERS.
- 2 PROPANE TANK PIT PER DETAIL A/SHEET 5.03.
- 3 ELECTRICAL POWER CONDUIT, TRANSFORMERS, AND PULL BOXES. SEE ELECTRICAL PLANS.
- 4 POWER METER BASE AND MAIN CIRCUIT BREAKER. SEE ELECTRICAL PLANS.
- 5 COMMUNICATION CONDUIT AND PULL BOXES. SEE ELECTRICAL PLANS.



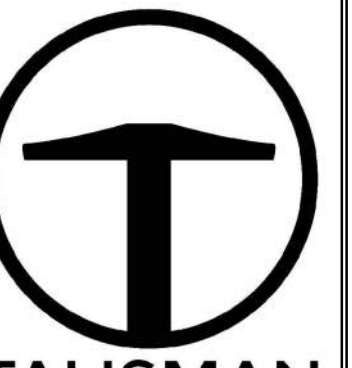

TALISMAN
CIVIL CONSULTANTS
6217 SOUTH STATE STREET
SUITE 200
MURRAY, UT 84107
801.743.1300

NO.	DATE	BY	REVISIONS

TCC JOB NUMBER: 17-200.08

VILLAGE NEST EAST PRUD
SITE CONSTRUCTION DRAWINGS
GRADING PLAN

DATE SUBMITTED: 06.15.2017

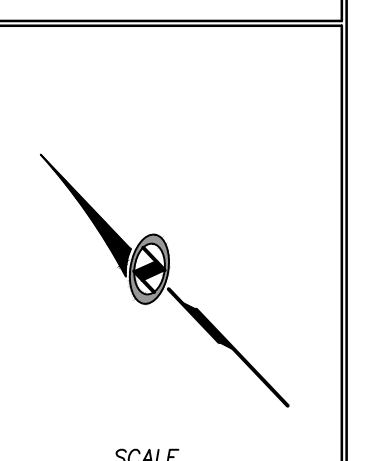
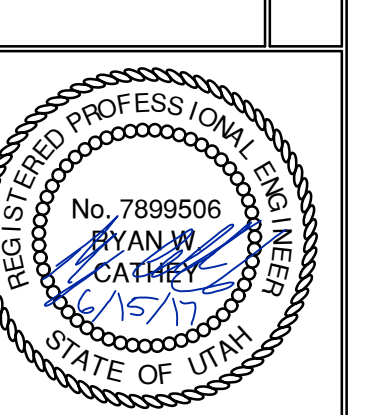

SHEET NUMBER
1.09

DATE: 5/03/17

PATH: N:\SIBD793\Coad\ Village_Nest_VP1096GR.dwg

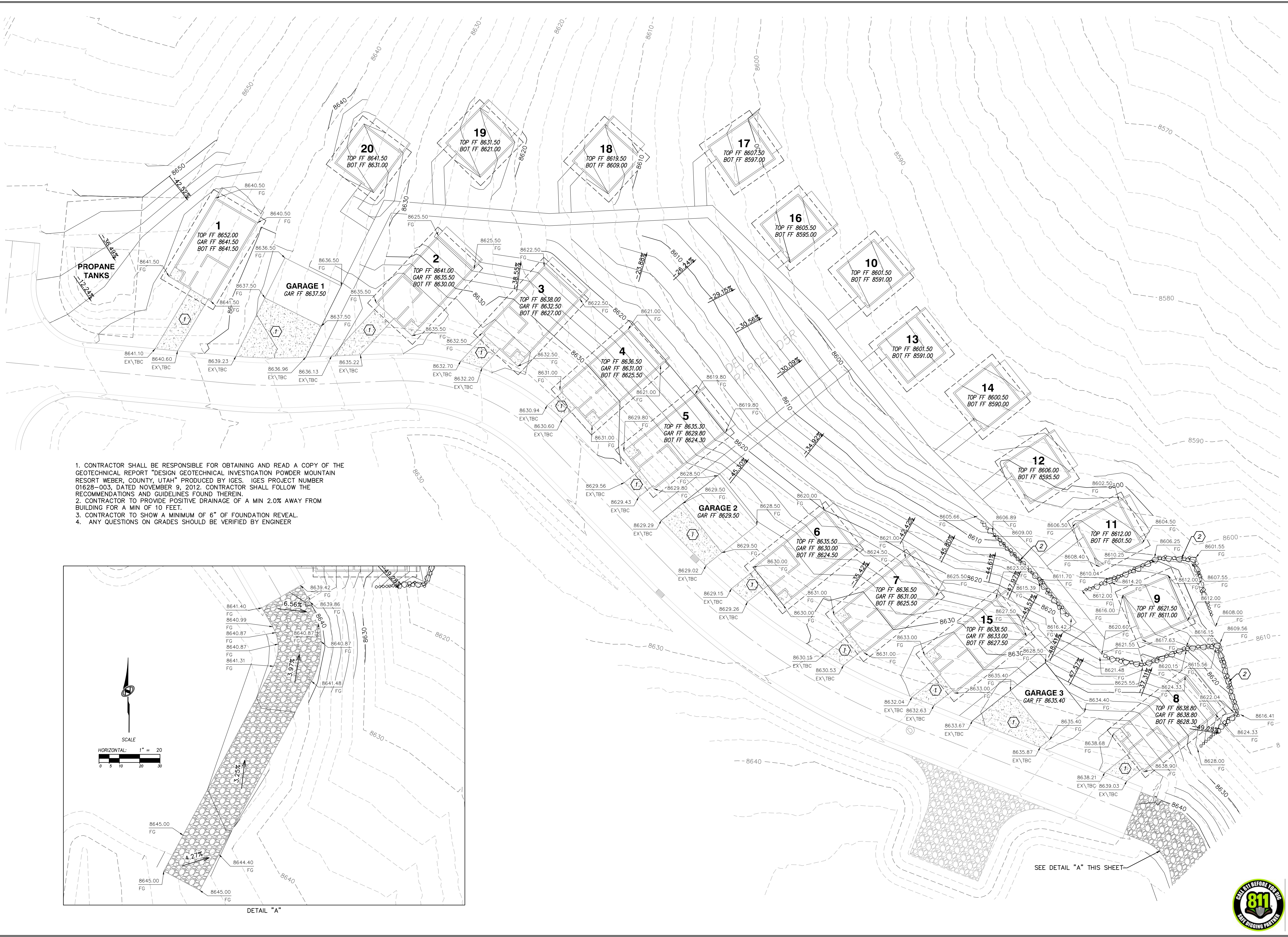

1. CONTRACTOR SHALL BE RESPONSIBLE FOR OBTAINING AND READ A COPY OF THE GEOTECHNICAL REPORT "DESIGN GEOTECHNICAL INVESTIGATION POWDER MOUNTAIN RESORT WEBER, COUNTY, UTAH" PRODUCED BY IGES. IGES PROJECT NUMBER 01628-003, DATED NOVEMBER 9, 2012. CONTRACTOR SHALL FOLLOW THE RECOMMENDATIONS AND GUIDELINES FOUND THEREIN.
2. CONTRACTOR TO PROVIDE POSITIVE DRAINAGE OF A MIN 2.0% AWAY FROM BUILDING FOR A MIN OF 10 FEET.
3. CONTRACTOR TO SHOW A MINIMUM OF 6" OF FOUNDATION REVEAL.
4. ANY QUESTIONS ON GRADES SHOULD BE VERIFIED BY ENGINEER

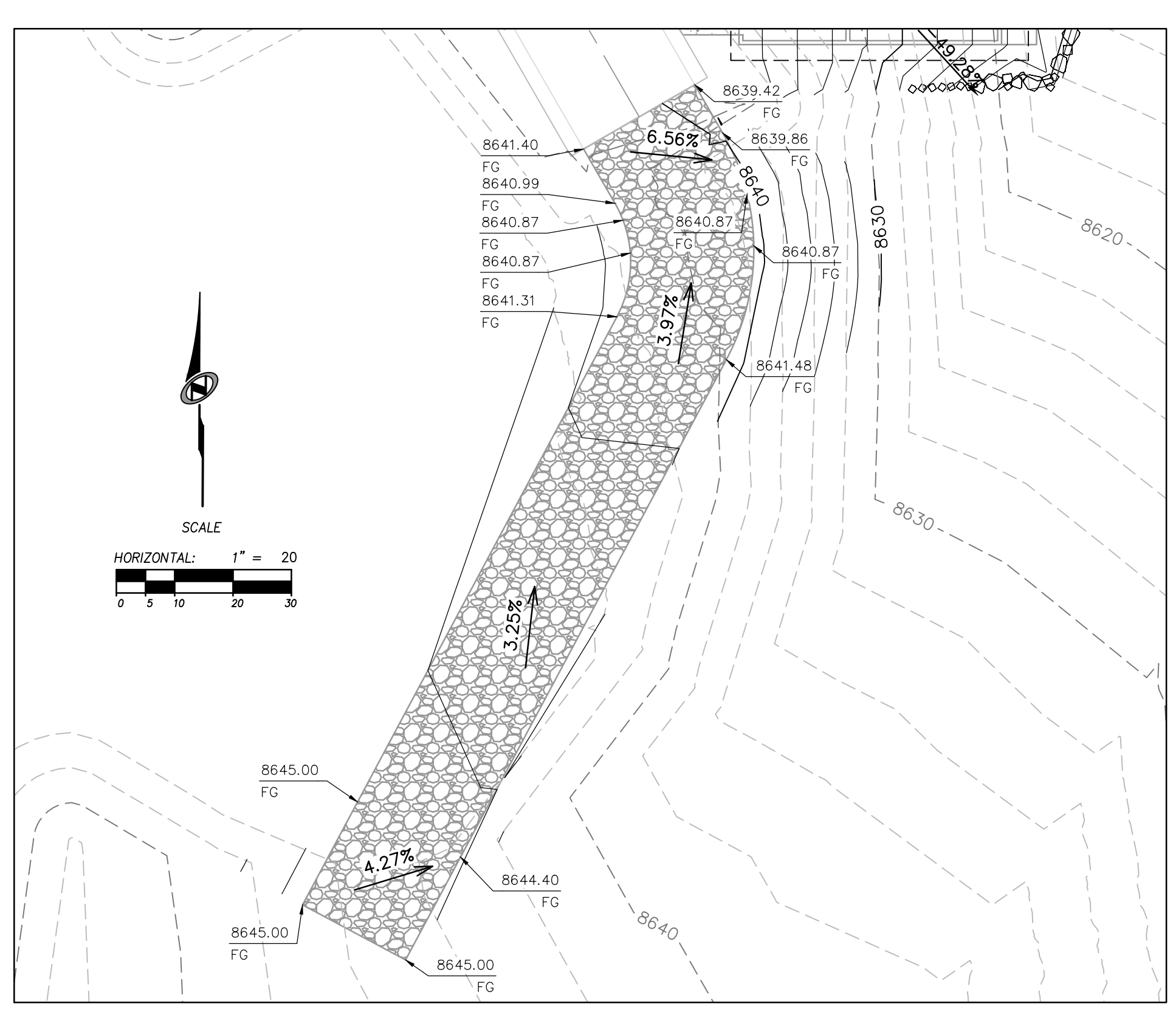

SEE DETAIL "A" THIS SHEET



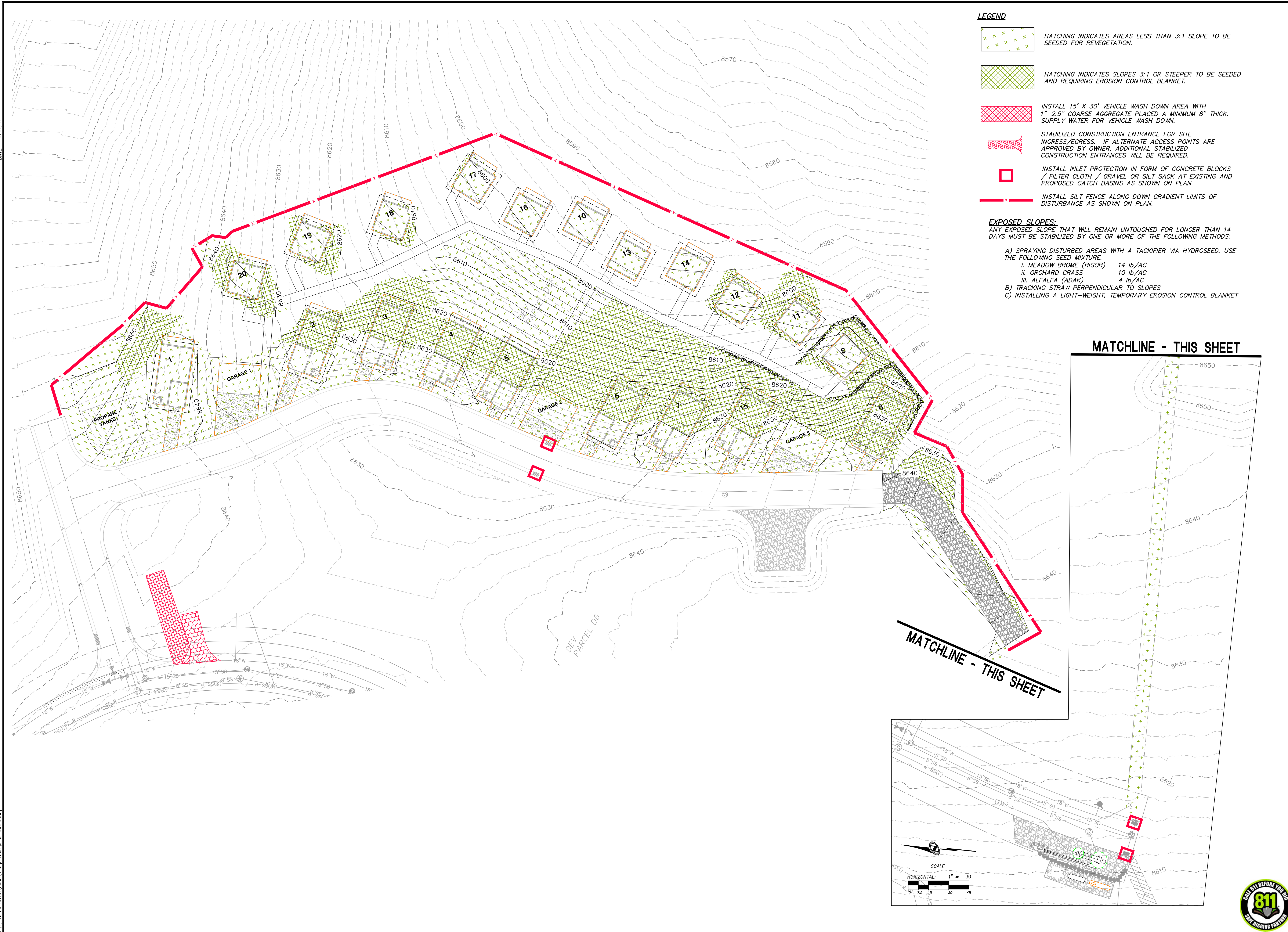

DATE: 5/03/17

PATH: N:\SIBD793\Cad\ Village_Nest_VP_406C.dwg

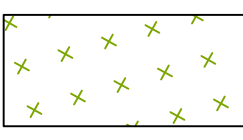
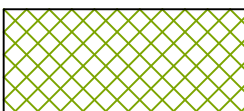
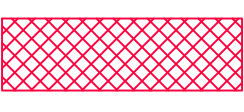
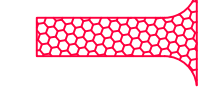

LEGEND

-  HATCHING INDICATES AREAS LESS THAN 3:1 SLOPE TO BE SEEDED FOR REVEGETATION.
-  HATCHING INDICATES SLOPES 3:1 OR STEEPER TO BE SEEDED AND REQUIRING EROSION CONTROL BLANKET.
-  INSTALL 15' X 30' VEHICLE WASH DOWN AREA WITH 1"-2.5" COARSE AGGREGATE PLACED A MINIMUM 8" THICK. SUPPLY WATER FOR VEHICLE WASH DOWN.
-  STABILIZED CONSTRUCTION ENTRANCE FOR SITE INGRESS/EGRESS. IF ALTERNATE ACCESS POINTS ARE APPROVED BY OWNER, ADDITIONAL STABILIZED CONSTRUCTION ENTRANCES WILL BE REQUIRED.
-  INSTALL INLET PROTECTION IN FORM OF CONCRETE BLOCKS / FILTER CLOTH / GRAVEL OR SILT SACK AT EXISTING AND PROPOSED CATCH BASINS AS SHOWN ON PLAN.
-  INSTALL SILT FENCE ALONG DOWN GRADIENT LIMITS OF DISTURBANCE AS SHOWN ON PLAN.

- EXPOSED SLOPES:**
 ANY EXPOSED SLOPE THAT WILL REMAIN UNTOUCHED FOR LONGER THAN 14 DAYS MUST BE STABILIZED BY ONE OR MORE OF THE FOLLOWING METHODS:
- A) SPRAYING DISTURBED AREAS WITH A TACKIFIER VIA HYDROSEED. USE THE FOLLOWING SEED MIXTURE:
 - i. MEADOW BROME (RIGOR) 14 lb/AC
 - ii. ORCHARD GRASS 10 lb/AC
 - iii. ALFALFA (ADAK) 4 lb/AC
 - B) TRACKING STRAW PERPENDICULAR TO SLOPES
 - C) INSTALLING A LIGHT-WEIGHT, TEMPORARY EROSION CONTROL BLANKET

MATCHLINE - THIS SHEET

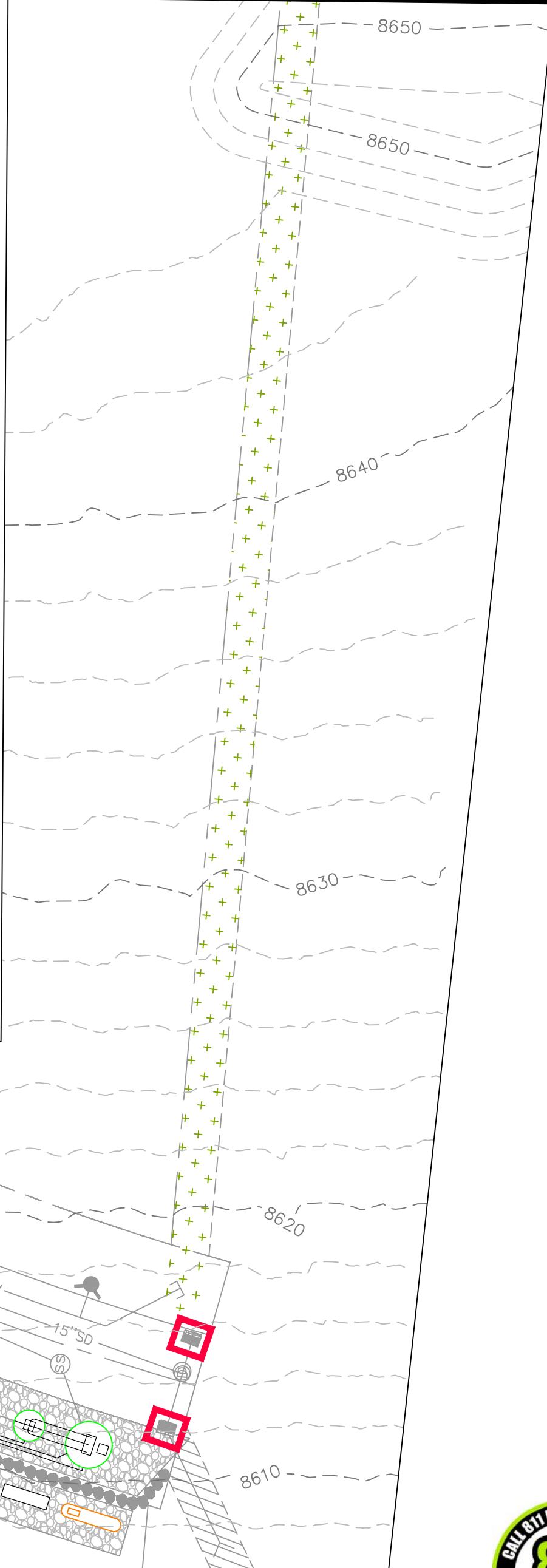

MATCHLINE - THIS SHEET

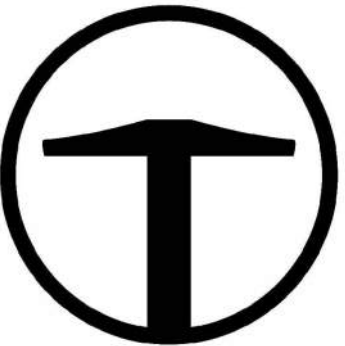
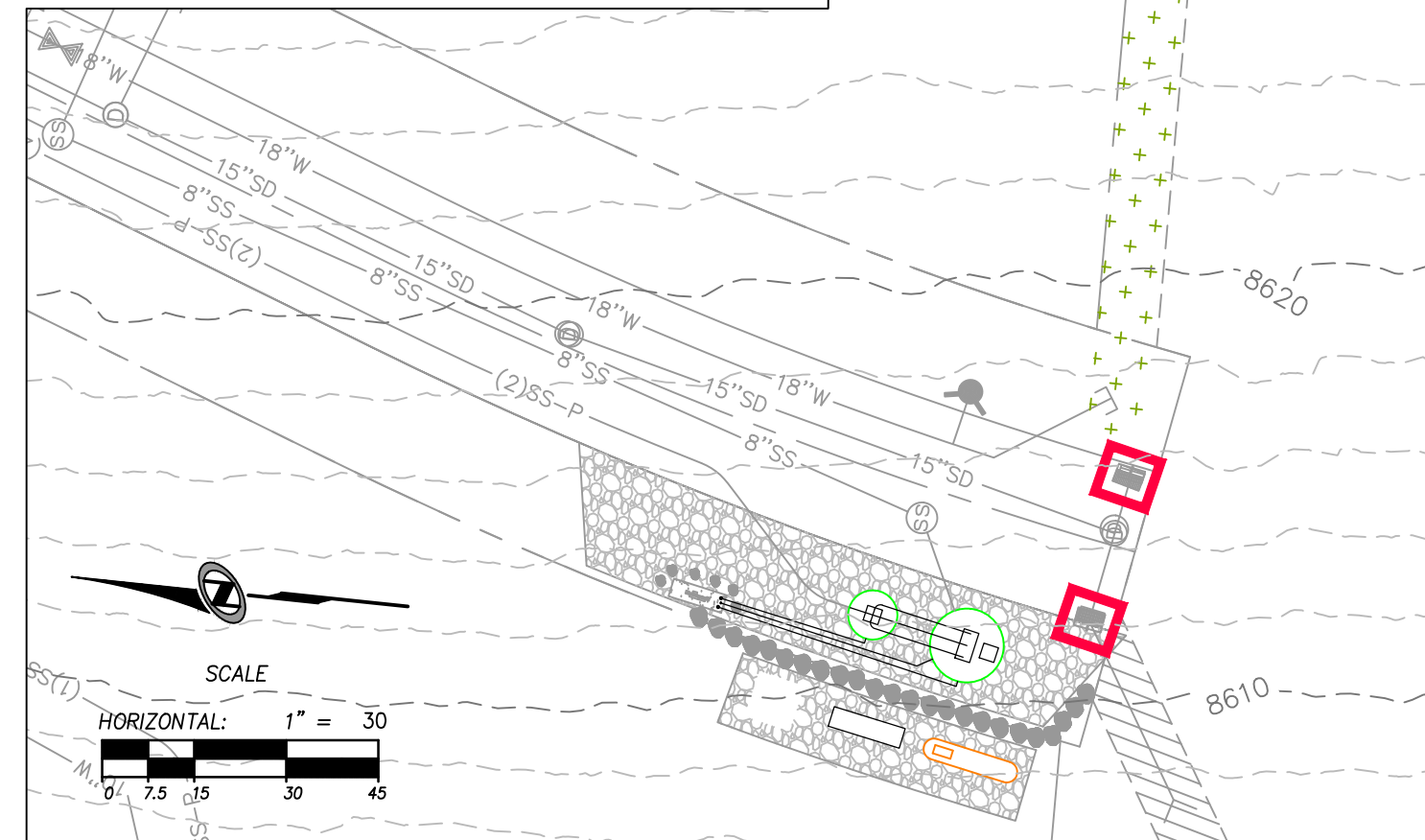

TALISMAN
 CIVIL CONSULTANTS
 6217 SOUTH STATE STREET
 SUITE 200
 MURRAY, UT 84107
 801.743.1300

NO.	DATE	BY	REVISIONS

VILLAGE NEST EAST PRUD
 SITE CONSTRUCTION DRAWINGS
 EROSION CONTROL PLAN

DATE SUBMITTED: 06.15.2017

TCC JOB NUMBER: 17-200.08

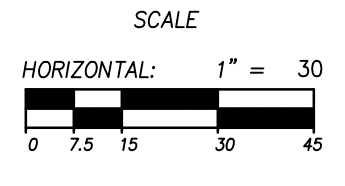
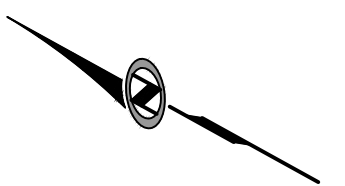
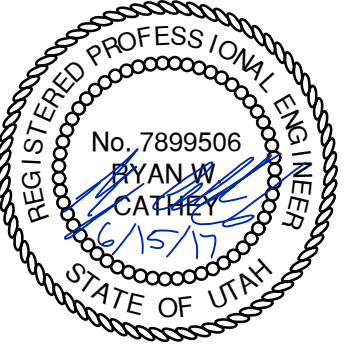

SHEET NUMBER
4.00



Silt fence

1. **GENERAL**
 - A. Description. A temporary sediment barrier consisting of a filter fabric stretched across and attached to supporting posts and entrenched.
 - B. Application. To intercept sediment from disturbed areas of limited extent.
 - C. Perimeter Control: Place barrier at down gradient limits of disturbance.
 - D. Sediment Barrier: Place barrier at toe of slope or soil stockpile.
 - E. Protection of Existing Waterways: Place barrier at top of stream bank.
 - F. Inlet Protection.
2. **PRODUCTS**
 - A. Fabric. Synthetic filter fabric shall be a pervious sheet of propylene, nylon, polyester, or polyethylene yarn. Synthetic filter fabric shall contain ultraviolet ray inhibitors and stabilizers to provide a minimum of 6 months of expected usable construction life at a temperature range of 0 deg F to 120 deg F.
 - B. Burlap. 10 ounces per square yard of fabric.
 - C. Posts. Either 2" x 4" diameter wood, or 1.33 pounds per linear foot steel with a minimum length of 5 feet, or steel posts with projections for fastening wire to them.
3. **EXECUTION**
 - A. Cut the fabric on site to desired width, unroll, and drape over the barrier. Secure the fabric toe with rocks or dirt and secure the fabric to the mesh with twin, staples or similar devices.
 - B. When attaching two silt fences together, place the end post of the second fence inside the end post of the first fence. Rotate both posts at least 180 degrees on a clockwise direction to create a tight seal with the filter fabric. Drive both posts into the ground and bury the flap.
 - C. When used to control sediments from a steep slope, place silt fences away from the toe of the slope for increased holding capacity.
 - D. Maintenance.
 - 1) Inspect immediately after each rainfall and at least daily during prolonged rainfall.
 - 2) Should the fabric on a silt fence or filter barrier decompose or become ineffective before the end of the expected usable life and the barrier still be necessary, replace the fabric promptly.
 - 3) Remove sediment deposits after each storm event. They must be removed when deposits reach approximately one-half the height of the barrier.
 - 4) Re-anchor fence as necessary to prevent shortcutting.
 - 5) Inspect for runoff bypassing ends of barriers or undercutting barriers.

6

Inlet protection - fence or straw bale

1. **GENERAL**
 - A. Description. A temporary sediment barrier around storm drain inlet.
 - B. Application. At inlets in paved or unpaved areas where up gradient area is to be disturbed by construction activities.
2. **PRODUCT** (Not used)
3. **EXECUTION**
 - A. Installation and application criteria.
 - 1) Provide up gradient sediment controls, such as silt fence during construction of inlet.
 - 2) When construction of inlet is complete erect straw bale barrier, silt fence or other approved sediment barrier surrounding perimeter of inlet.
 - 3) Install filter fabric completely around grate.
 - B. Maintenance.
 - 1) Inspect inlet protection after every large storm event and at a minimum of once monthly.
 - 2) Remove sediment accumulated when it reaches 4-inches in depth.
 - 3) Repair or re-align barrier or fence as needed.
 - 4) Look for bypassing or undercutting and re-compact soil around barrier or fence as required.

14

Stabilized roadway entrance

1. **GENERAL**
 - A. Description. A temporary stabilized pad of gravel for controlling equipment and construction vehicle access to the site.
 - B. Application. At any site where vehicles and equipment enter the public right of way.
2. **PRODUCT** (Not used)
3. **EXECUTION**
 - A. Clear and grub area and grade to provide maximum slope of 1 percent away from paved roadway.
 - B. Compact subgrade.
 - C. Place filter fabric under stone if desired (recommended for entrance area that remains more than 3 months).
 - D. Maintenance.
 - 1) Prevent tracking or flow of mud into the public right-of-way.
 - 2) Periodic top dressing with 2-inch stone may be required, as conditions demand, and repair any structures used to trap sediments.
 - 3) Inspect daily for loss of gravel or sediment buildup.
 - 4) Inspect adjacent area for sediment deposit and install additional controls as necessary.
 - 5) Expand stabilized area as required to accommodate activities.

18

NARRATIVE: THIS PLAN MAY BE USED FOR THE CONSTRUCTION OF A STORM WATER BEST MANAGEMENT PRACTICE (BMP). IT IS NOT INCLUSIVE OF ALL PRACTICES AVAILABLE AND IS ONLY SPECIFIC TO THE CONSTRUCTION OF THIS TYPE. MAINTENANCE OF THIS TYPE OF INSTALLATION IS IMPORTANT AND SHOULD BE CONTINUOUSLY MONITORED BY THE CONTRACTOR AND ENGINEER. DETAILS SHOWN HERE HIGHLIGHT IMPORTANT PARTS OF CONSTRUCTION, AND SHOULD BE MODIFIED AS NEEDED.

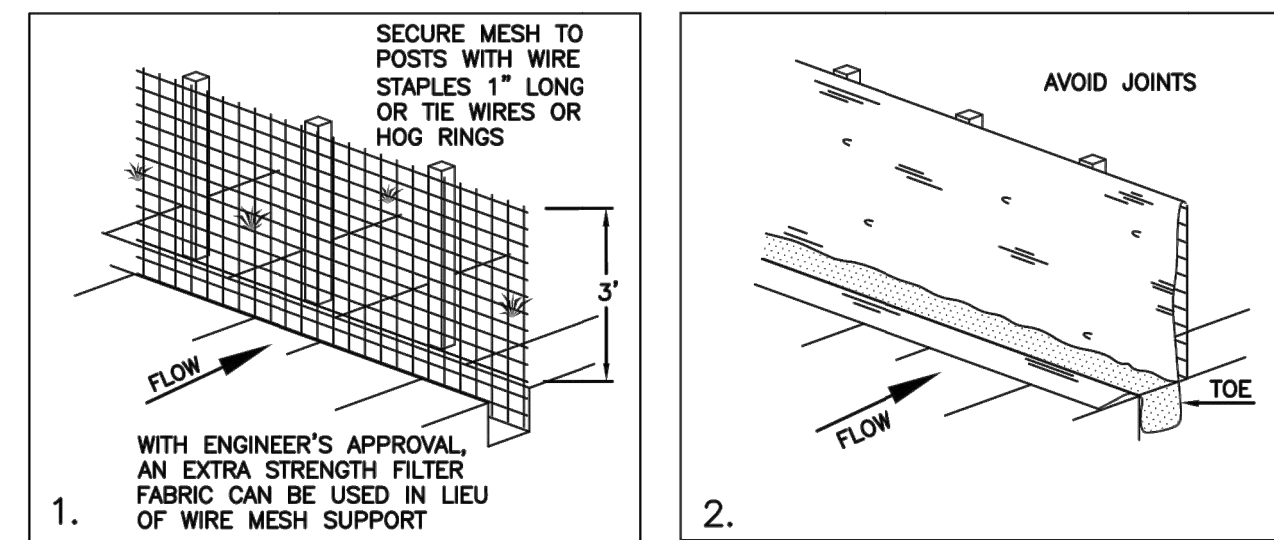

INSTALLATION SEQUENCE

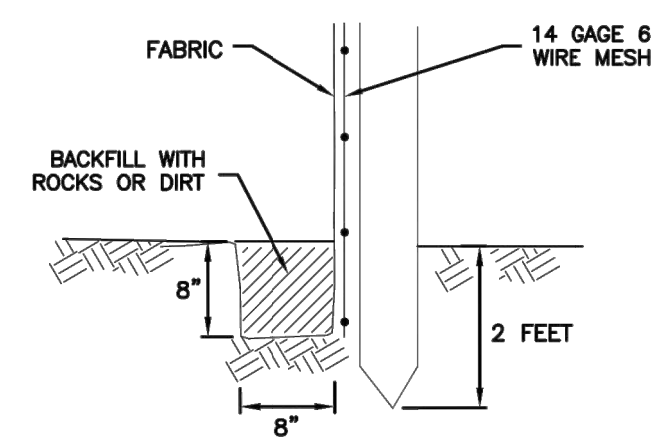

TOE DETAIL

Silt fence

February 2006

7

Plan 122

NARRATIVE: THIS PLAN MAY BE USED FOR THE CONSTRUCTION OF A STORM WATER BEST MANAGEMENT PRACTICE (BMP). IT IS NOT INCLUSIVE OF ALL PRACTICES AVAILABLE AND IS ONLY SPECIFIC TO THE CONSTRUCTION OF THIS TYPE. MAINTENANCE OF THIS TYPE OF INSTALLATION IS IMPORTANT AND SHOULD BE CONTINUOUSLY MONITORED BY THE CONTRACTOR AND ENGINEER. DETAILS SHOWN HERE HIGHLIGHT IMPORTANT PARTS OF CONSTRUCTION, AND SHOULD BE MODIFIED AS NEEDED.

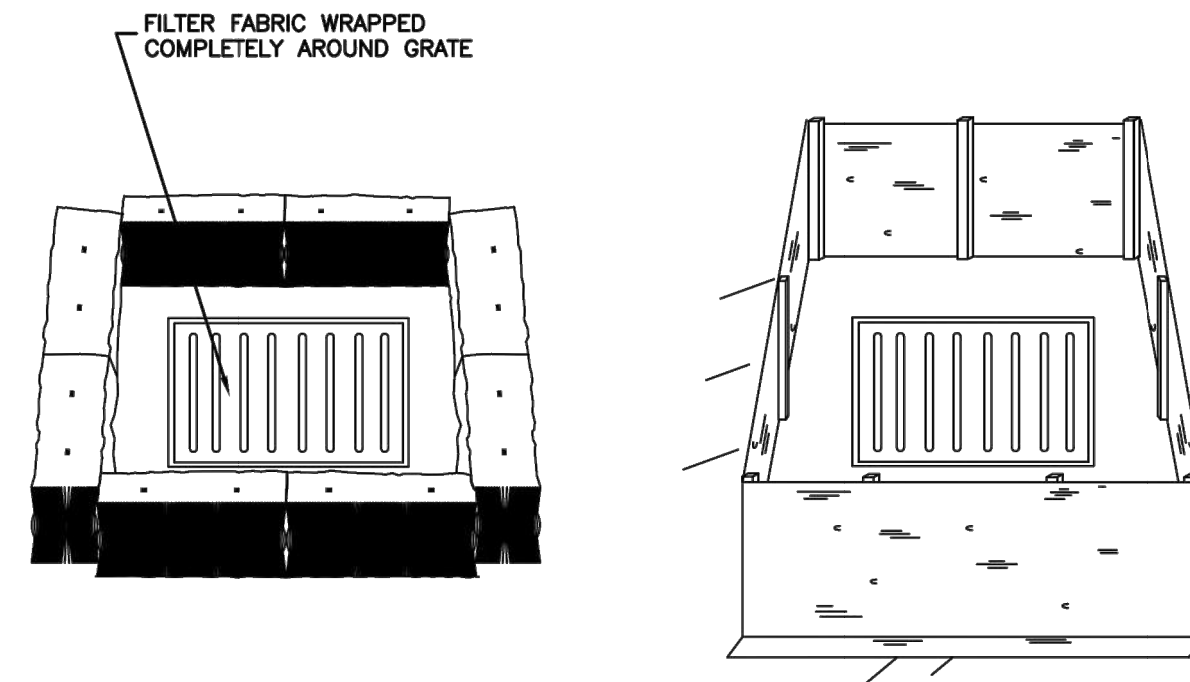

STRAW BALE BARRIER
(PLAN No. 121)

SILT FENCE
(PLAN No. 122)

February 2006

15

Inlet protection - fence or straw bale

Plan 124
Sheet 3 of 3

NARRATIVE: THIS PLAN MAY BE USED FOR THE CONSTRUCTION OF A STORM WATER BEST MANAGEMENT PRACTICE (BMP). IT IS NOT INCLUSIVE OF ALL PRACTICES AVAILABLE AND IS ONLY SPECIFIC TO THE CONSTRUCTION OF THIS TYPE. MAINTENANCE OF THIS TYPE OF INSTALLATION IS IMPORTANT AND SHOULD BE CONTINUOUSLY MONITORED BY THE CONTRACTOR AND ENGINEER. DETAILS SHOWN HERE HIGHLIGHT IMPORTANT PARTS OF CONSTRUCTION, AND SHOULD BE MODIFIED AS NEEDED.

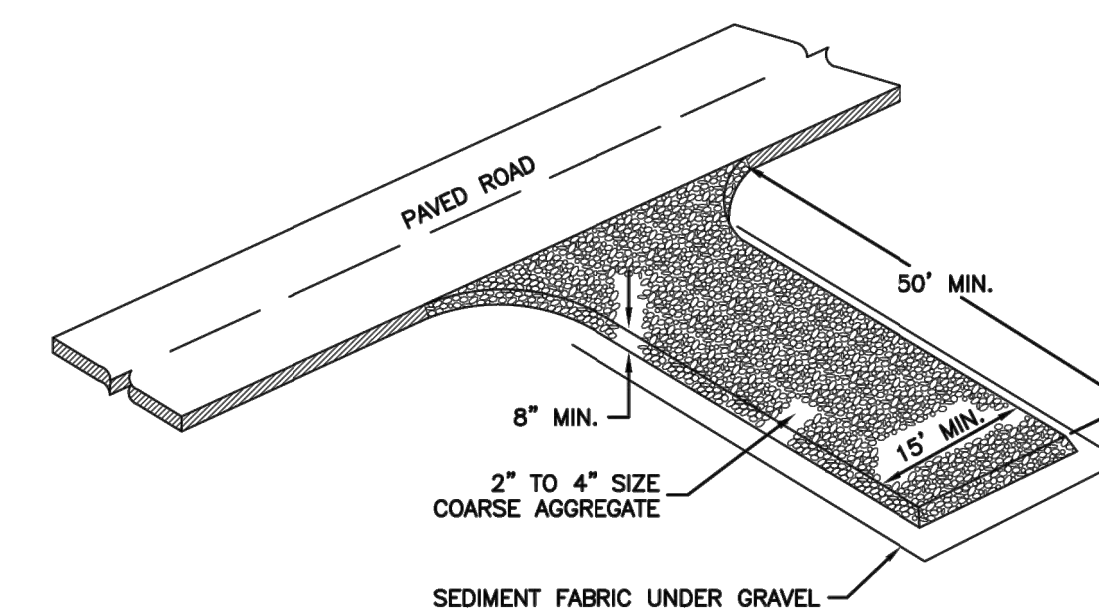

Stabilized roadway entrance

February 2006

19

Plan 126

NO.	BY	DATE	REVISIONS

VILLAGE NEST EAST PRUD
SITE CONSTRUCTION DRAWINGS
EROSION CONTROL DETAILS

DATE SUBMITTED: 06.15.2017

TCC JOB NUMBER: 17-200.08

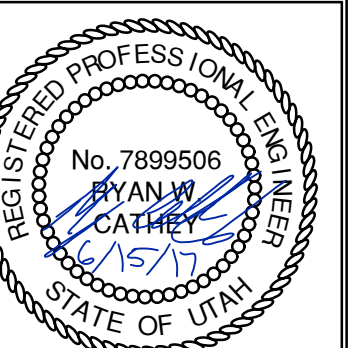

SHEET NUMBER

4.01

DATE: 5/03/17

PATH: N:\SIBD793\Cad\ Village_Nest_VP_50001.dwg

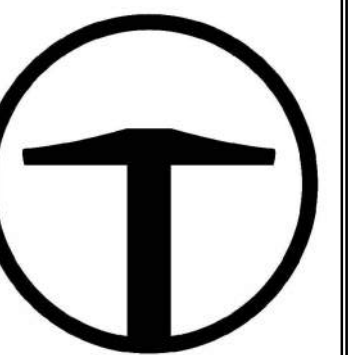

TALISMAN
CIVIL CONSULTANTS
6217 SOUTH STATE STREET
SUITE 200
MURRAY, UT 84107
801.743.1300

REVISED	DATE	BY	NO.

DATE SUBMITTED: 06.15.2017

TCC JOB NUMBER: 17-200.08

VILLAGE NEST EAST PRUD
SITE CONSTRUCTION DRAWINGS
DETAILS

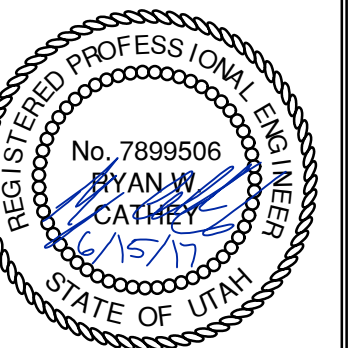

SHEET NUMBER

5.00

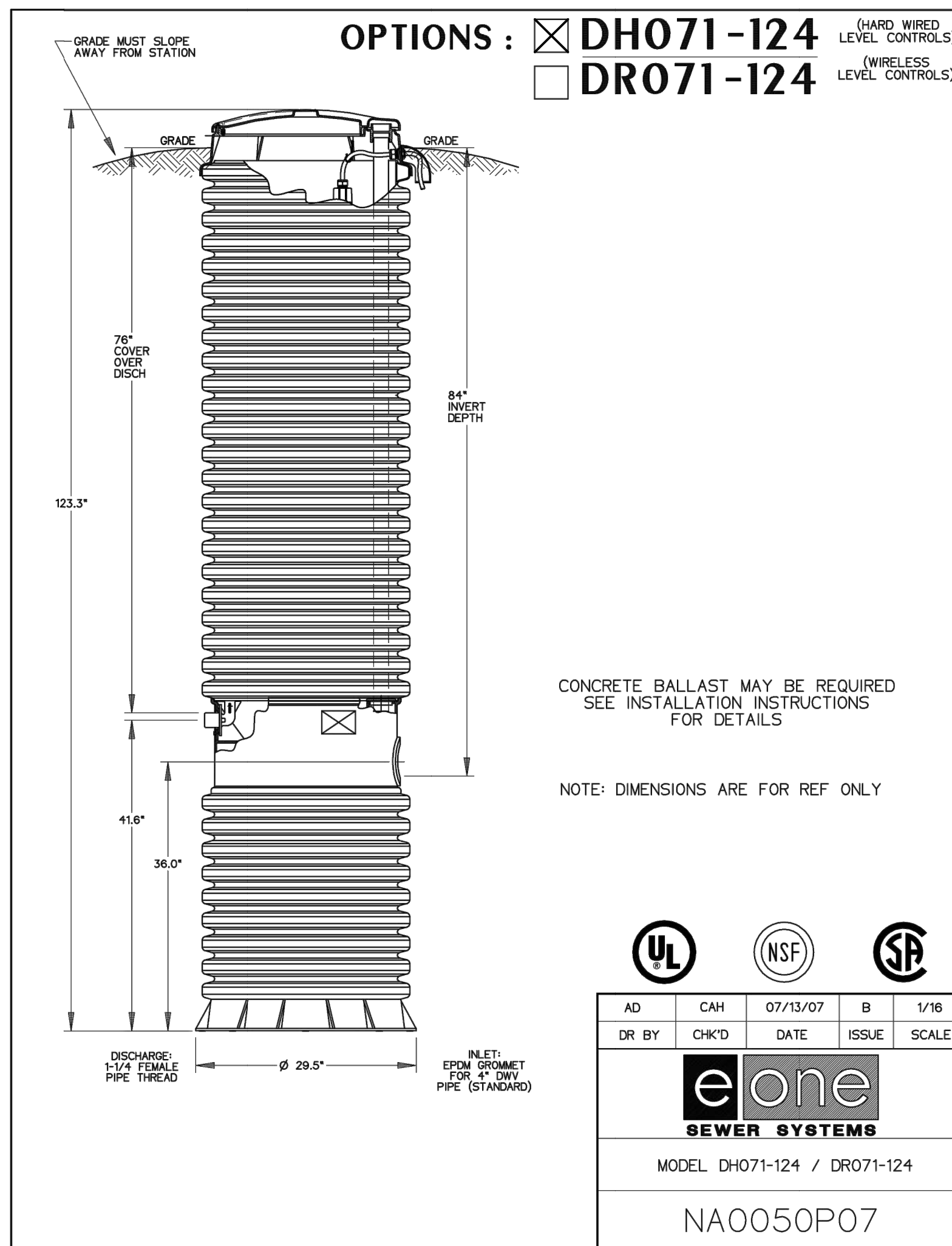
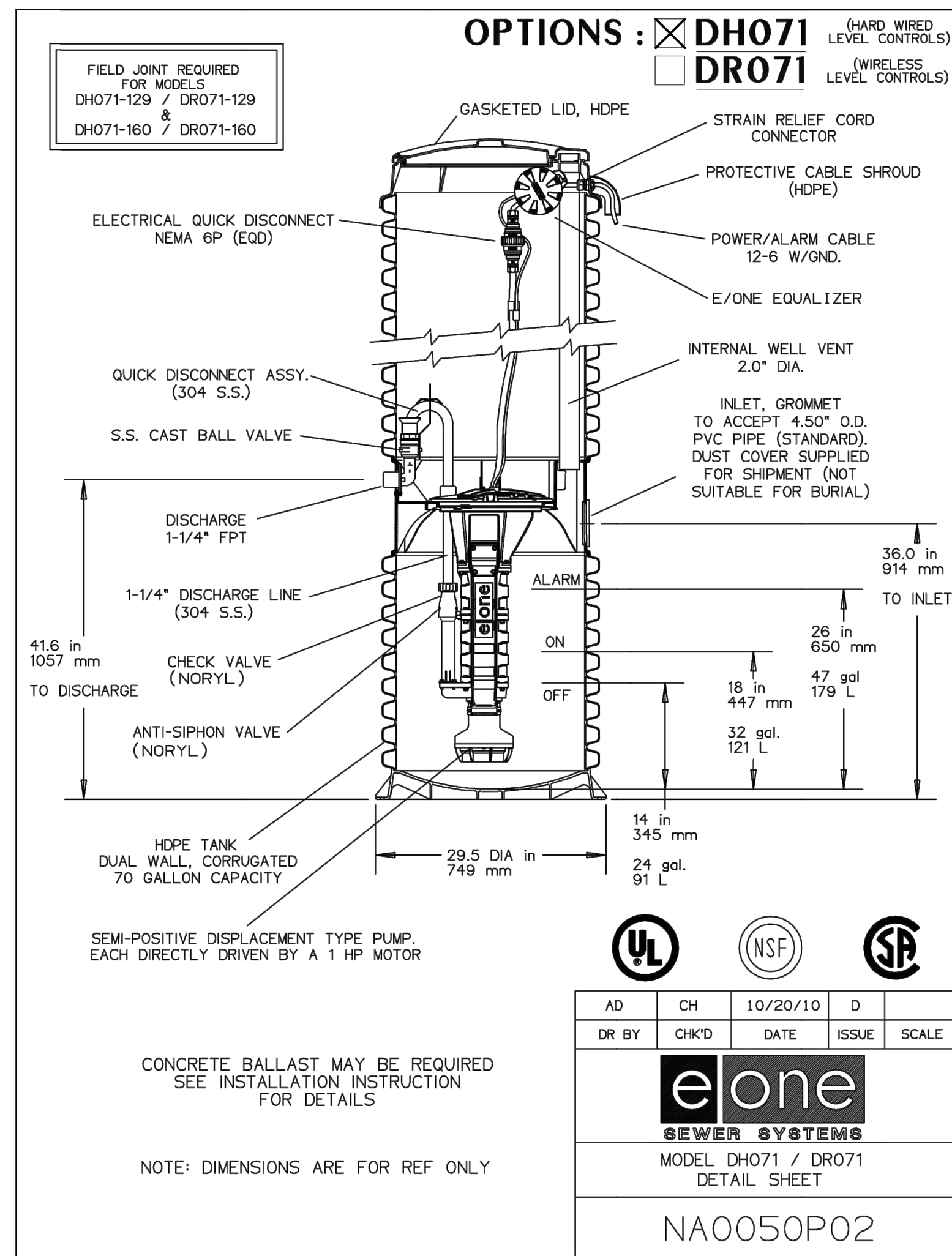
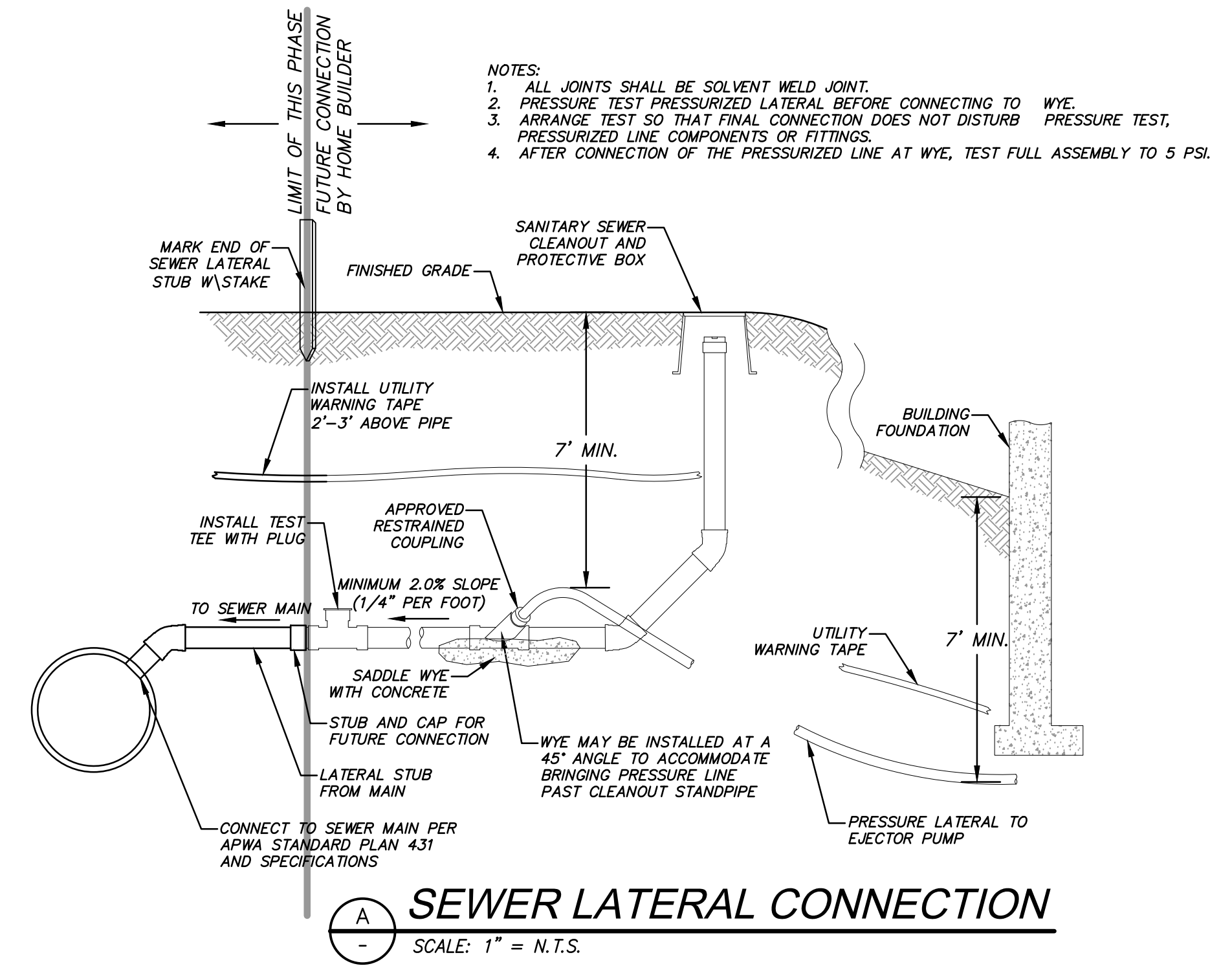

GRINDER PUMP STATION DETAIL
SCALE: 1" = N.T.S.

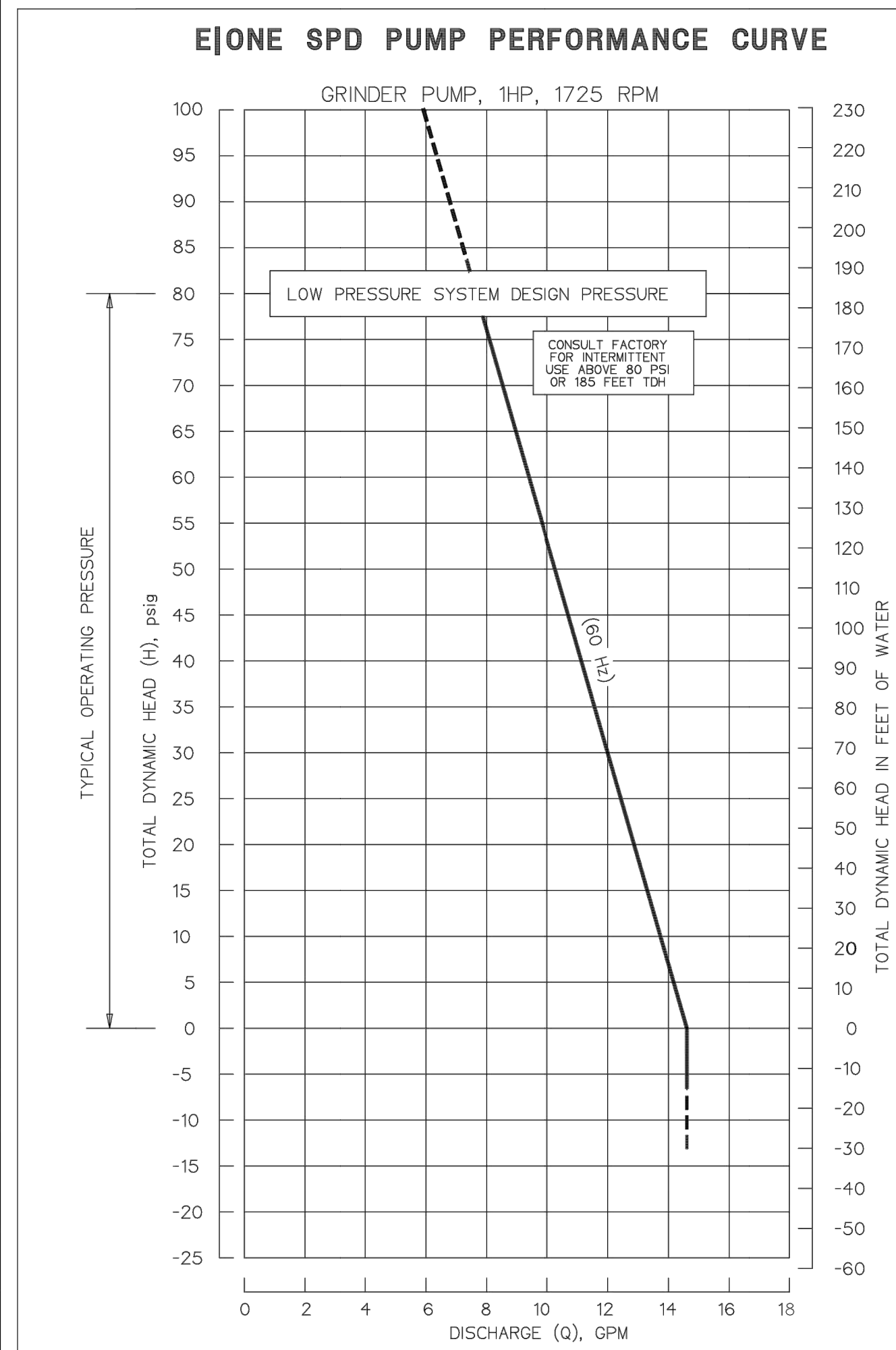

DATE: 5/03/17

Curb and gutter

1. **GENERAL**
 - A. Variance from specified dimensions and slopes must be acceptable to the ENGINEER. System configuration may be changed at ENGINEER's discretion.
 - B. Additional requirements are specified in APWA Section 32 16 13.
2. **PRODUCTS**
 - A. Base Course: Untreated base course, APWA Section 32 11 23. Do not use gravel as a base course without ENGINEER's permission.
 - B. Expansion Joint Filler: 1/2-inch thick type F1 full depth, APWA Section 32 13 73.
 - C. Concrete: Class 4000, APWA Section 03 30 04. If necessary, provide concrete that achieves design strength in less than 7 days. Use caution; however, as concrete crazing (spider cracks) may develop if air temperature exceeds 90 degrees F.
 - D. Concrete Curing Agent: Clear membrane forming compound with fugitive dye (Type ID Class A), APWA Section 03 39 00.
3. **EXECUTION**
 - A. Base Course Placement: APWA Section 32 05 10. Thickness is 6-inches if flow-line grade is 0.5 percent (s=0.005) or greater. If slope is less, provide 8-inches. Maximum lift thickness before compaction is 8-inches when using riding equipment or 6-inches when using hand held equipment. Compaction is 95 percent or greater relative to a modified proctor density, APWA Section 31 23 26.
 - B. Concrete Placement: APWA Section 03 30 10.
 - 1) Install expansion joints vertical, full depth, with top of filler set flush with concrete surface. Install at the start or end of a street intersection curb return. Expansion joints are not required in concrete placement using slip-form construction.
 - 2) Install contraction joints vertical, 1/8-inch wide or 1/4 slab thickness if the slab is greater than 8-inches thick. Match joint location in adjacent Portland-cement concrete roadway pavement.
 - 3) Provide 1/2-inch radius edges. Apply a broom finish. Apply a curing agent.
 - C. Protection and Repair: Protect concrete from deicing chemicals during cure. Repair construction that does not drain. If necessary, fill flow-line with water to verify.

28

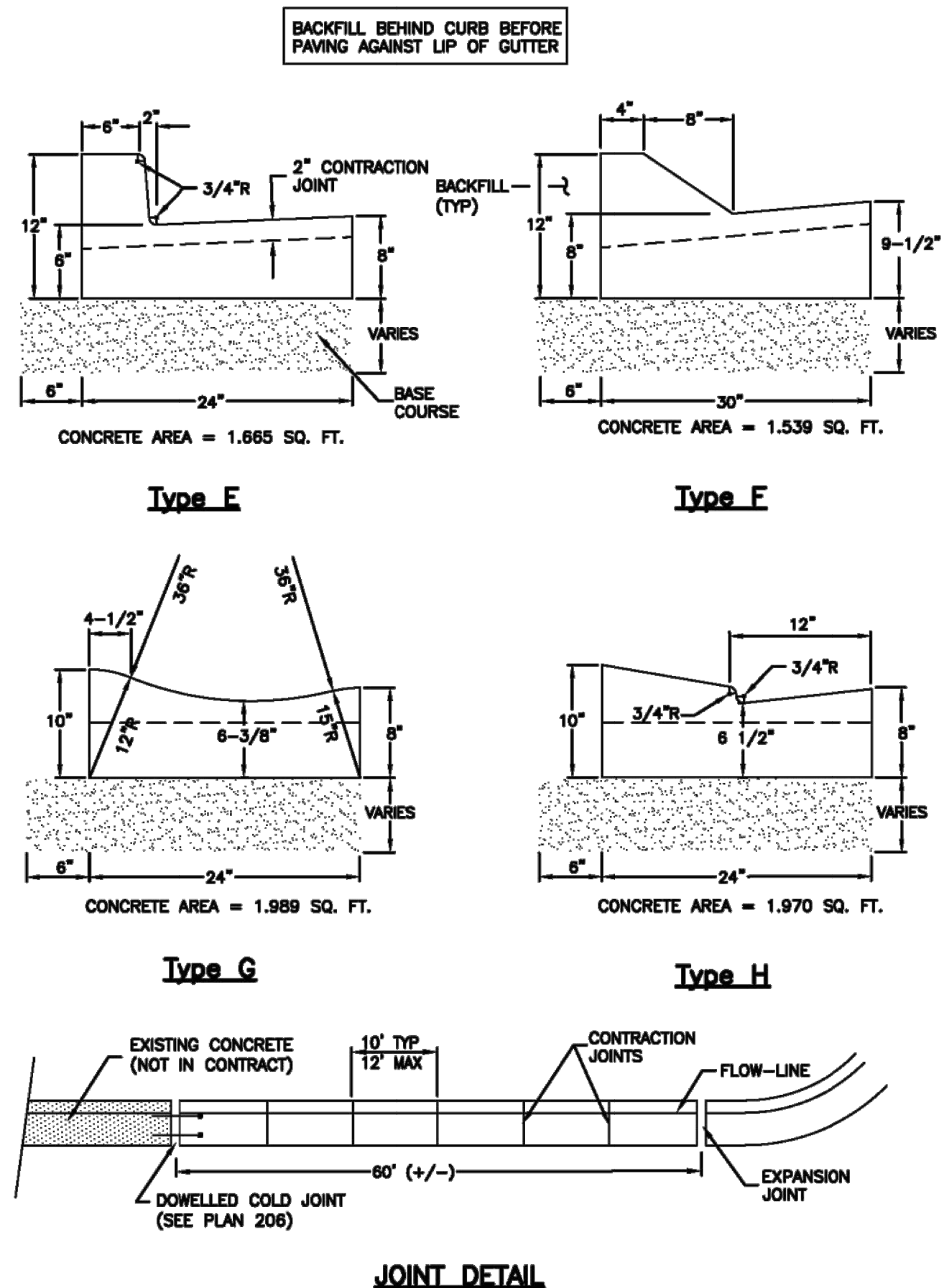

Curb and gutter

Plan 205
Sheet 2 of 3

April 2011

29

Direct bearing thrust block

1. **GENERAL**
 - A. Thrust design for pipe sizes or configurations not shown require special design.
 - B. Bearing areas, volumes, and special thrust blocking details shown on Drawings take precedence over this plan.
 - C. Restraint sizing is based upon a maximum operating pressure of 150 psi and a test pressure of 200 psi, and a minimum soil bearing strength of 2,000 psf. Operating pressures in excess of 150 psi or soils with less than 2,000 pound bearing strength will require special design.
 - D. Before backfilling around thrust block, secure inspection of installation by ENGINEER.
2. **PRODUCTS**
 - A. Base Course: Untreated base course, APWA Section 32 11 23. Do not use gravel as a base course without ENGINEER's permission.
 - B. Backfill: Common fill, APWA Section 31 05 13. Maximum particle size 2-inches.
 - C. Thrust Blocks: Concrete Class 4000, APWA Section 03 30 04.
 - D. Grease: Non-oxide poly-FM.
3. **EXECUTION**
 - A. Pour concrete against undisturbed soil.
 - B. Pipe Joints: Do not cover with concrete. Leave completely accessible.
 - C. Grease: Apply grease to all buried metal surfaces. Wrap with polyethylene sheet and tape wrap.
 - D. Locking restraint devices may be used in conjunction with concrete thrust blocking (at discretion of ENGINEER).
 - E. Base Course and Backfill Placement: Maximum lift thickness is 8-inches before compaction. Compaction is 95 percent or greater relative to a modified proctor density, APWA Section 31 23 26.

266

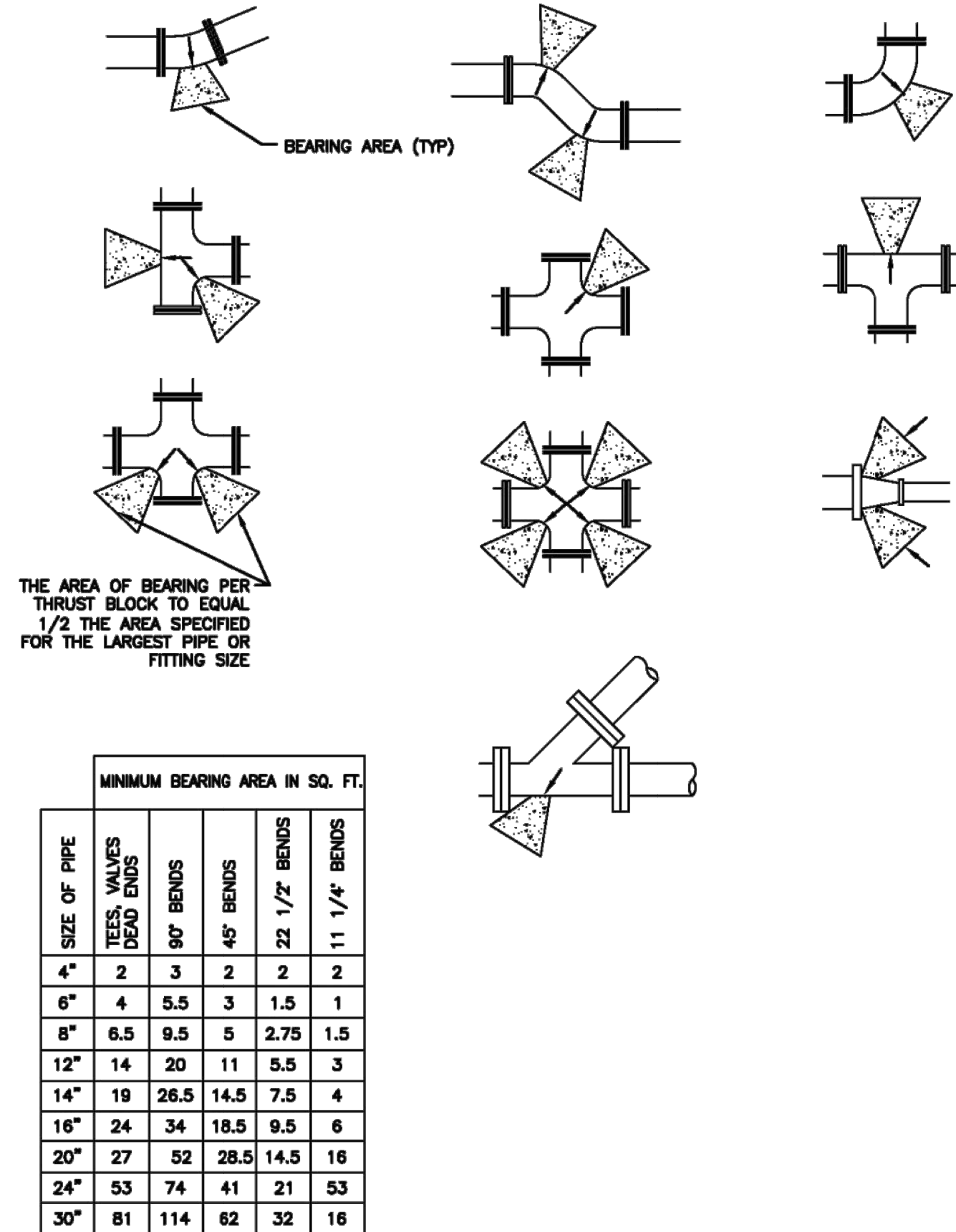

Direct bearing thrust block

Plan 561

August 2010

267

3" and 4" Compound meter with 2" bypass

1. **GENERAL**
 - A. Configuration may be changed at ENGINEER's discretion.
 - B. Additional requirements are specified in APWA Section 33 12 16.
2. **PRODUCTS**
 - A. Small Fittings: Brass. Do not use galvanized materials.
 - B. Blocking: Clay brick or concrete block.
 - C. Drain Gravel: Sewer rock, ASTM size no. 3 (2" to 1") or equal, APWA Section 31 05 13.
3. **EXECUTION**
 - A. Control Valve: Install valve with valve box adjacent to main.
 - B. Center frame and cover over water meter.
 - C. Allow 1-inch clearance around waterline where water line passes through concrete box wall. Seal opening with compressible seal.

242

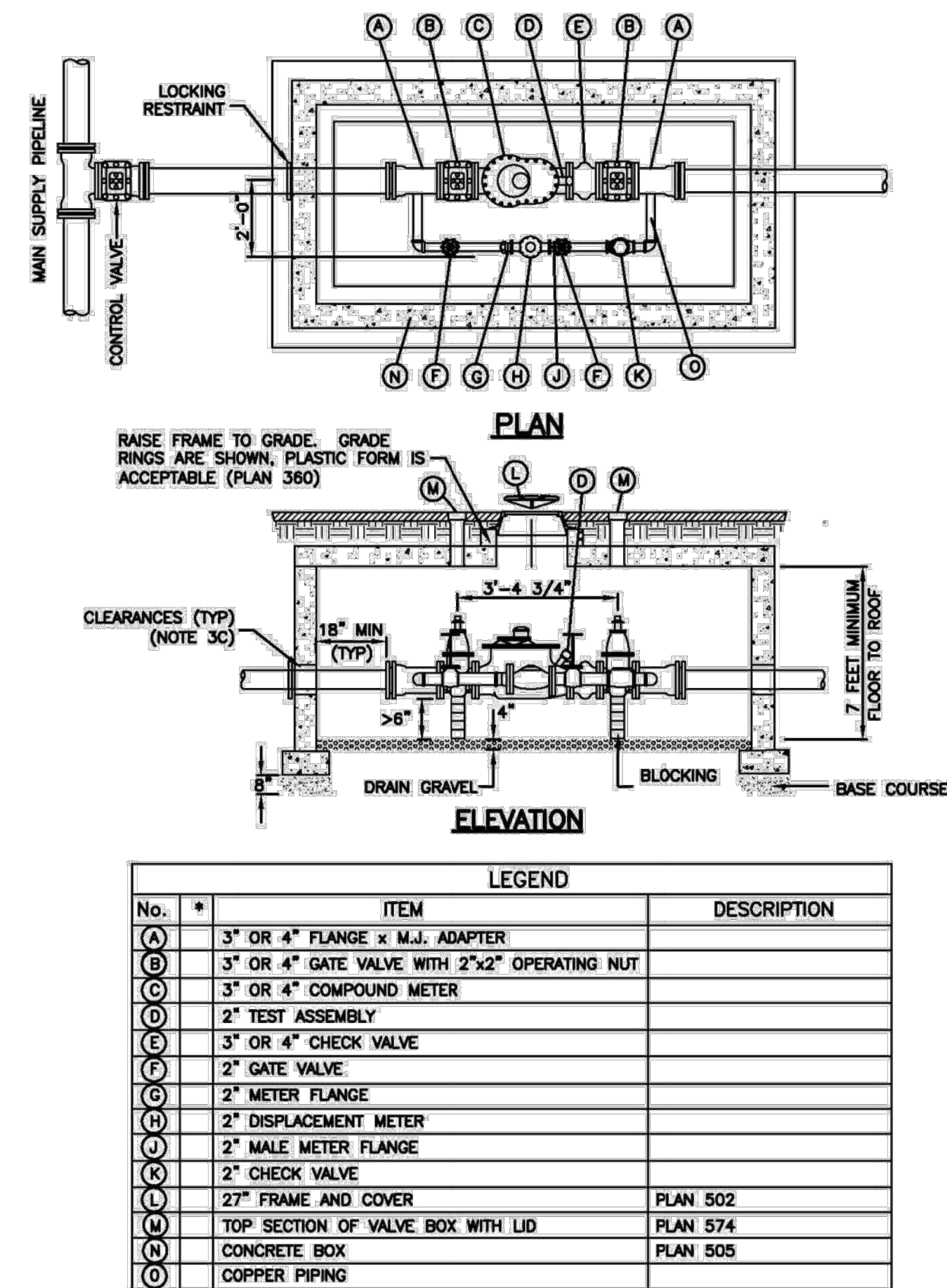

3" and 4" Compound meter with 2" bypass

Plan 523

August 2001

243



**VILLAGE NEST EAST PRUD
SITE CONSTRUCTION DRAWINGS
DETAILS**

DATE SUBMITTED: 06.15.2017

TCC JOB NUMBER: 17-200.08

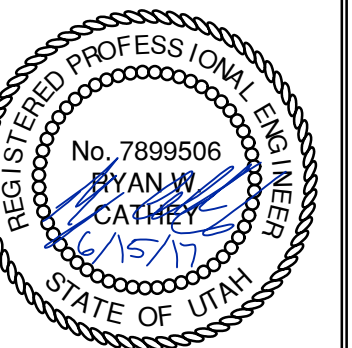

SHEET NUMBER

5.01

PATH: N:\SIBD793\Cad\Village_Nest_VP_VP501D1.dwg

1 1/2" and 2" Service taps

1. GENERAL
 - A. Before backfilling around taps, secure inspection of installation by ENGINEER.
2. PRODUCTS
 - A. Base Course: Untreated base course, APWA Section 32 11 23. Do not use gravel as a base course without ENGINEER's permission.
 - B. Backfill: Common fill, APWA Section 31 05 13. Maximum particle size 2-inches.
 - C. Tape: Teflon tape is required on all taps.
3. EXECUTION
 - A. Tapping: Place taps a minimum of 36-inches apart. Use a tapping tool that is sized corresponding to the size of the service line to be installed. No taps within 36-inches of end of pipe.
 - B. PVC or AC Pipe: A service saddle clamp is required on all PVC and AC pipe taps unless specified otherwise.
 - C. Backfill: Maximum lift thickness is 8-inches before compaction. Compaction is 95 percent or greater relative to a modified proctor density, APWA Section 31 23 26.
 - D. Blocks: Clay brick or concrete block required under valve box to assure a 1" or greater space between the box and the corporation stop and pipe assembly.

264

Sanitary sewer manhole

1. GENERAL
 - A. The drawing shows typical pipe connections. Refer to construction drawings for connection locations or refer to field location of existing piping when engineering pipe connection to the manhole.
 - B. Manhole size.
 - 1) Diameter is 4 feet: For sewers under 12" diameter.
 - 2) Diameter is 5 feet: For sewers 12" and larger, or when 3 or more pipes intersect the manhole.
2. PRODUCTS
 - A. Base Course: Untreated base course, APWA Section 32 11 23. Do not use gravel as a base course without ENGINEER's permission.
 - B. Backfill: Common fill, APWA Section 31 05 13. Maximum particle size 2-inches.
 - C. Concrete: Class 4000, APWA Section 03 30 04.
 - D. Riser and Reducing Riser: ASTM C 478.
 - E. Reinforcement: Deformed, 60 ksi yield grade steel, ASTM A 615.
 - F. Grout: 2 parts sand to 1 part cement mortar, ASTM C 1329.
 - G. Stabilization-Separation Geotextile: Moderate or high at CONTRACTOR's choice, APWA Section 31 05 19.
3. EXECUTION
 - A. Foundation Stabilization: Get ENGINEER's permission to use a sewer rock or a granular backfill borrow in a geotextile wrap to stabilize an unstable foundation.
 - B. Base Course Placement: APWA Section 32 11 23. Maximum lift thickness is 8-inches before compaction. Compaction is 95 percent or greater relative to a modified proctor density, APWA Section 31 23 26.
 - C. Invert Cover. During construction, place invert covers over the top of pipe in manholes that currently convey sewerage. See Plan 412.
 - D. Pipe Connections: Grout around all pipe openings.
 - E. Pipe Seal: Install rubber-based pipe seals on all plastic pipes when connecting plastic pipes to manholes. Hold water-stop in place with stainless steel bands.
 - F. Joints: Place flexible gasket-type sealant in all riser joints. Finish with grout.
 - G. Adjustment: If the required manhole adjustment is more than 1'-0", remove the cone and grade rings and adjust the manhole elevation with the appropriate manhole section, the cone section, and the grade rings or plastic form to make frame and lid match finish grade.
 - H. Finish: Provide smooth and neat finishes on interior of cones, shafts, and rings. Imperfect moldings or honeycombs will not be accepted.
 - I. Backfill: Provide backfill against the manhole shaft. Pea gravel and recycled RAP aggregate is NOT ALLOWED. Water jetting is NOT allowed. Maximum lift thickness is 8-inches before compaction. Compaction is 95 percent or greater relative to a standard proctor density, APWA Section 31 23 26.

212

Sewer lateral connection

1. GENERAL
 - A. Before installation, secure acceptance by ENGINEER for all pipe, fittings, and couplings to be used.
 - B. Before backfilling, secure inspection of installation by ENGINEER. Give at least 24 hours notice.
 - C. Verify if CONTRACTOR or agency is to install the wye.
2. PRODUCTS
 - A. Base Course: Untreated base course, APWA Section 32 11 23. Do not use gravel as a base course without ENGINEER's permission.
 - B. Backfill: Common fill, APWA Section 31 05 13. Maximum particle size 2-inches.
 - C. Provide agency approved wye or tee with appropriate donut.
 - D. Stainless steel straps required.
3. EXECUTION
 - A. Tape wrap pipe as required by soil conditions.
 - B. Remove core plug from sewer main. Do not break into sewer main to make connection.
 - C. Base Course and Backfill Placement: Maximum lift thickness is 8-inches before compaction. Compaction is 95 percent or greater relative to a standard proctor density, APWA Section 31 23 26.

218

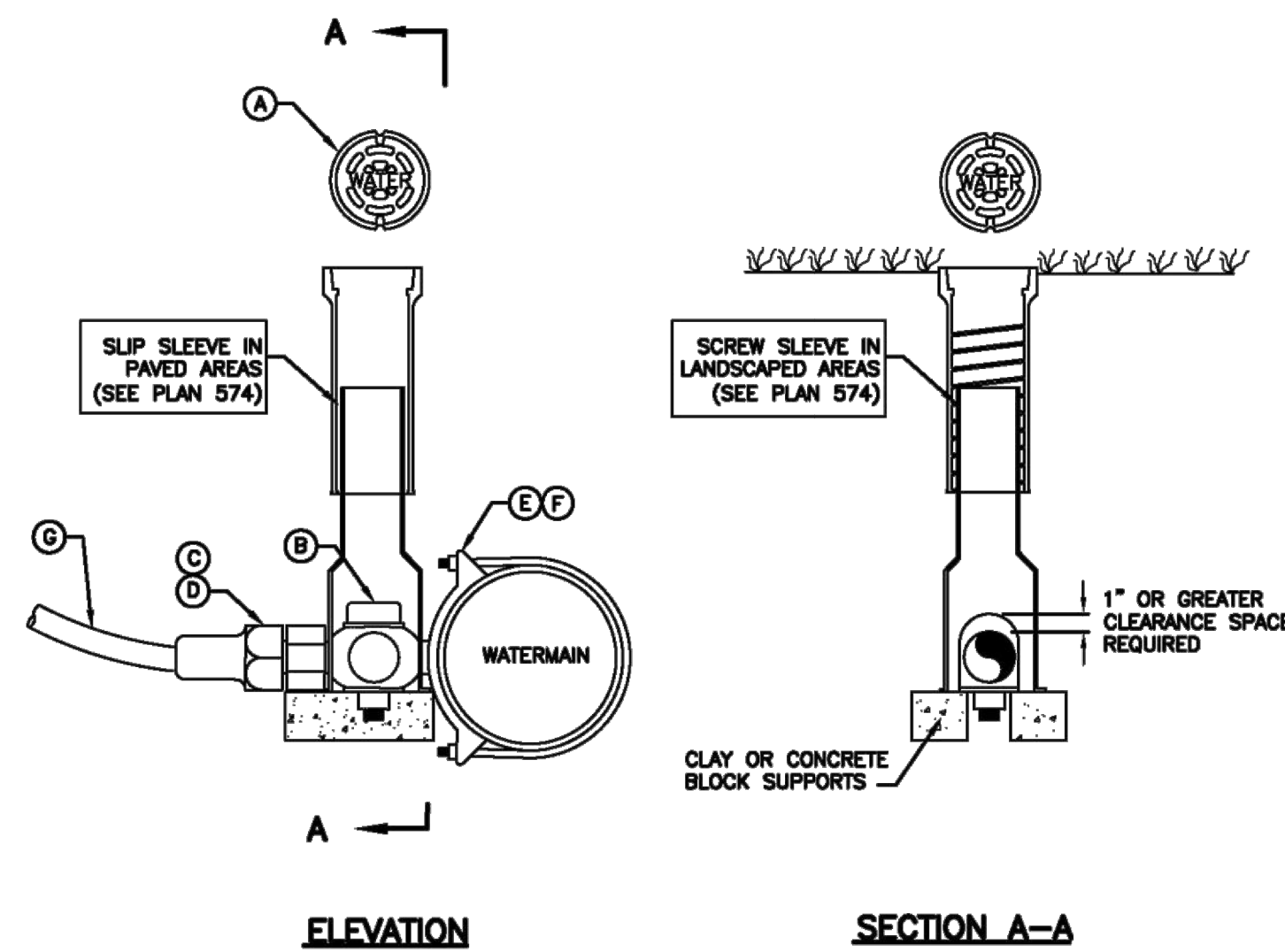

LEGEND			
No.	*	ITEM	DESCRIPTION
(A)		VALVE BOX WITH LID	2 PIECE CAST IRON
(B)		CORPORATION STOP	BRASS
(C)		COPPER ADAPTER	
(D)		FLARE OR PACK JOINT COPPER ADAPTER	
(E)		SERVICE SADDLE CLAMP	D.I., A.C., C.I.
(F)		SERVICE SADDLE CLAMP	P.V.C.
(G)		COPPER PIPE (SERVICE LINE)	TYPE K (SOFT)

* FURNISHED BY UTILITY AGENCY

1 1/2" and 2" Service taps

Plan 552

August 2001

265

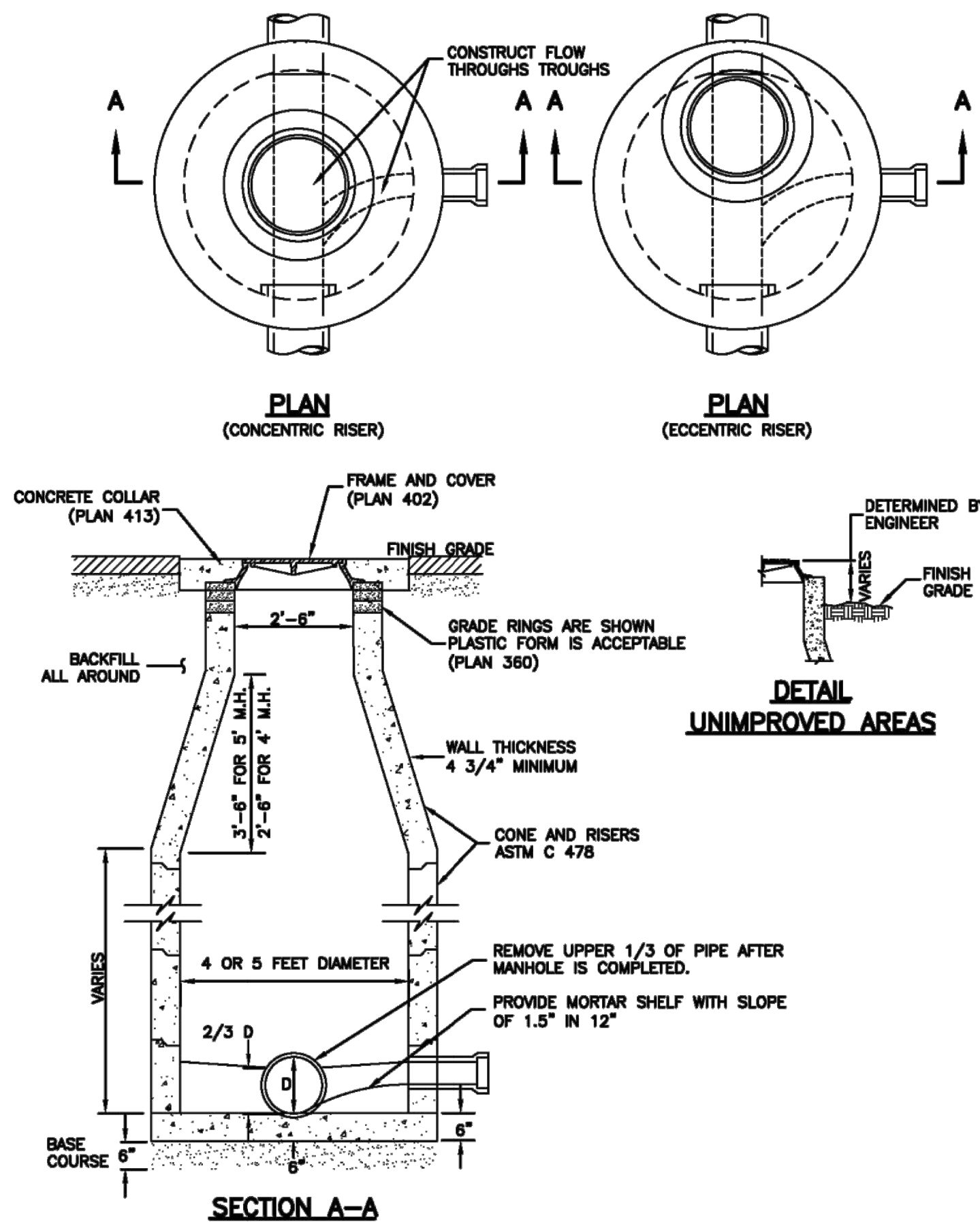

April 2011

Sanitary sewer manhole

Plan 411

213

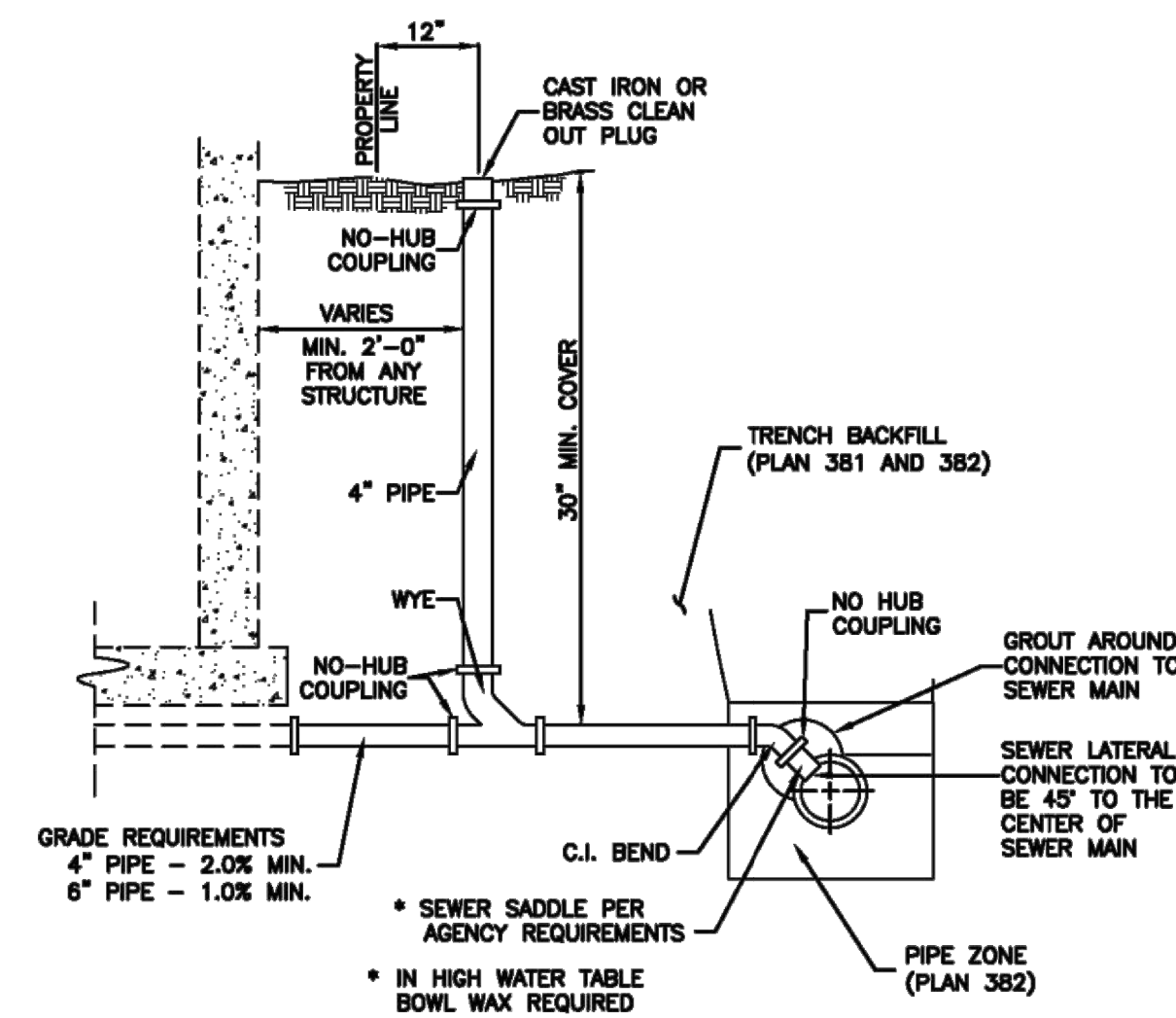

January 2011

Sewer lateral connection

Plan 431

219

DATE: 5/03/17

PATH: N:\SIB0793\Cad\Nest\VP\F50307.dwg

4" washout valve

1. **GENERAL**
 - A. Before backfilling, secure inspection of installation by ENGINEER.
 - B. Water mains 12-inches and larger will require a special washout assembly design.
2. **PRODUCTS**
 - A. Base Course: Untreated base course, APWA Section 32 11 23. Do not use gravel as a base course without ENGINEER's permission.
 - B. Backfill: Common fill, APWA Section 31 05 13. Maximum particle size 2-inches.
 - C. Concrete: Class 4000, APWA Section 03 30 04.
3. **EXECUTION**
 - A. Pour concrete against undisturbed soil.
 - B. Apply tape wrap to the exterior of all galvanized pipe per AWWA C209.
 - C. Place plastic sheet at least 6 mils thick over drain gravel to prevent silting.
 - D. After installation of washout valve assembly, verify the washout valve riser drains to gravel.
 - E. Backfill and Base Course Placement: Maximum lift thickness is 8-inches before compaction. Compaction is 95 percent or greater of a modified proctor density, APWA Section 31 23 26.

270

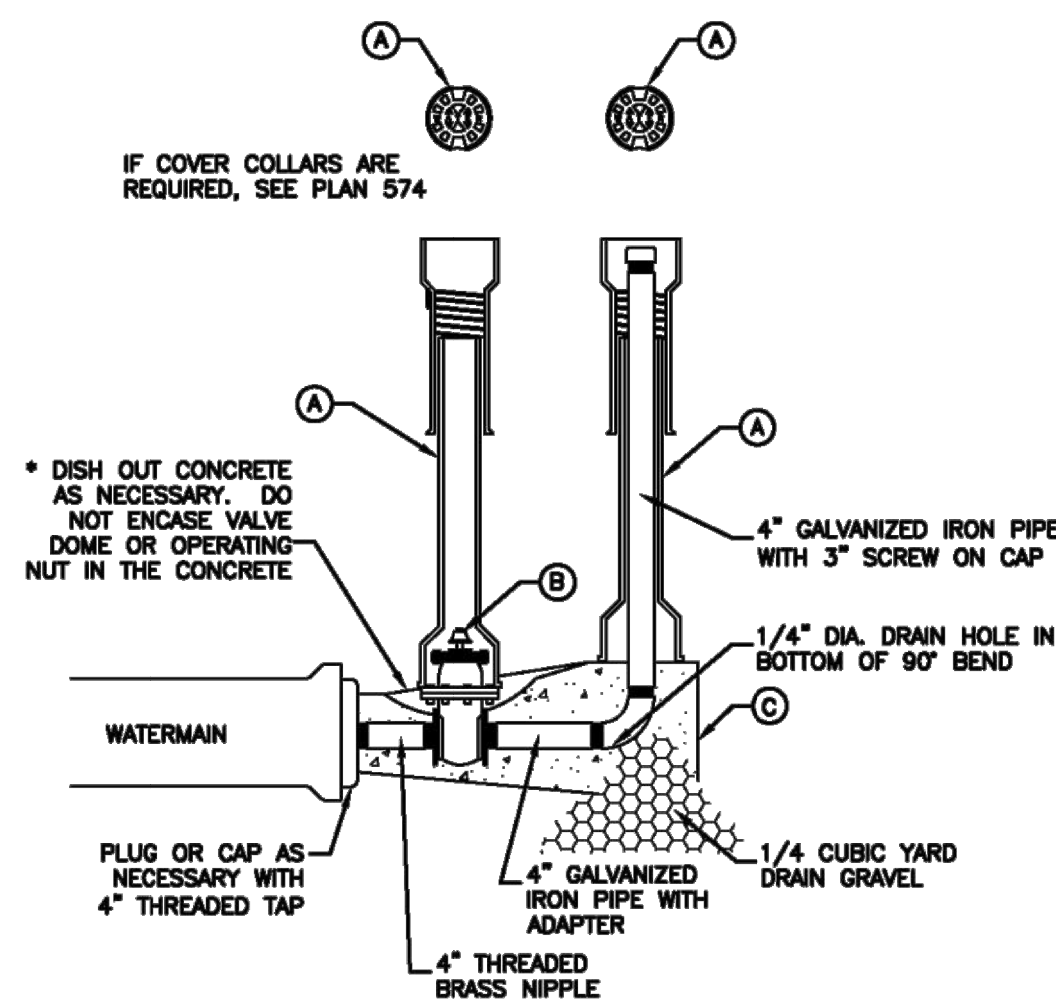

LEGEND		
No.	ITEM	DESCRIPTION
Ⓐ	VALVE BOX WITH LID	2 PIECE CAST IRON
Ⓑ	4" GATE VALVE WITH SCREW ENDS	2" x 2" OPERATING NUT
Ⓒ	CONCRETE THRUST BLOCK	PLAN 561

4" Washout valve

Plan 571

February 2011

271

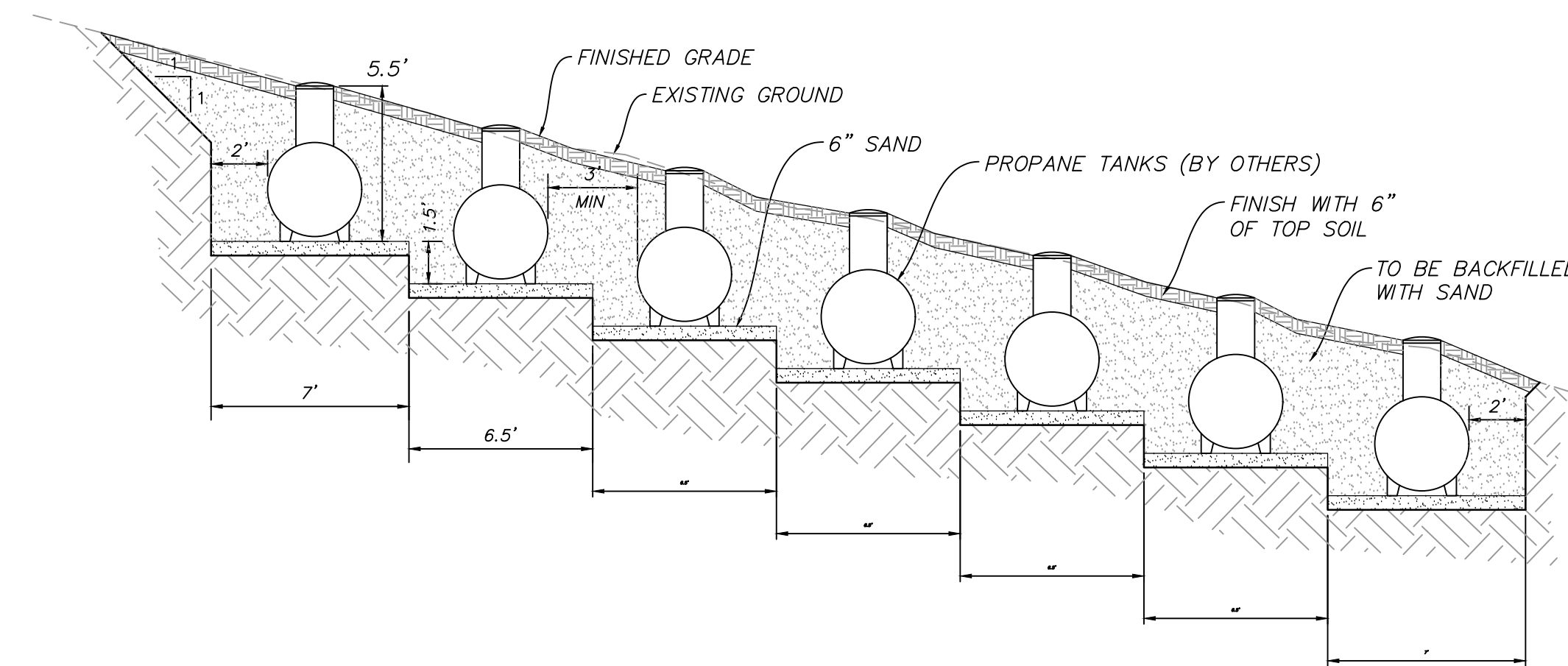

SECTION A-A

Ⓐ
—
NTS
PROPANE TANK PIT

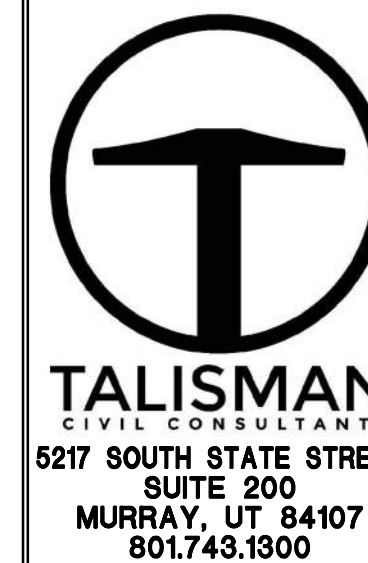

TALISMAN
CIVIL CONSULTANTS
6217 SOUTH STATE STREET
SUITE 200
MURRAY, UT 84107
801.743.1300

NO.	BY	DATE	REVISIONS

VILLAGE NEST EAST PRUD
SITE CONSTRUCTION DRAWINGS
DETAILS

DATE SUBMITTED: 06.15.2017

TCC JOB NUMBER: 17-200.08

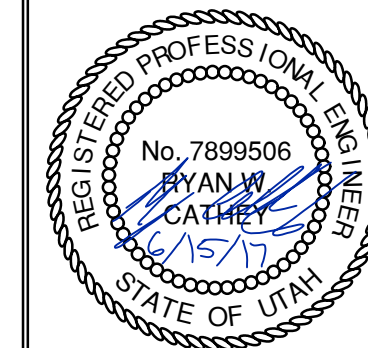

SHEET NUMBER

5.03