

Sun Crest Meadows Subdivision Phase 1

Weber County, Utah
A Part of the Northwest Quarter of Section 32,
Township 6 North, Range 2 West, Salt Lake Base & Meridian

Date of the survey noted in the heading (Meaning the date, year and month the survey markers were placed).
WCO 106-1-5(a)(2); WCO 106-1-8(c)(1); UCA 17-23-17(3)(b)

The existing location, widths, and other dimensions of all existing or platted streets within and immediately adjacent (within 30') to the tract to be subdivided. WCO 106-1-5(a)(6)

North Quarter Corner of Section 32,
T. 6 N., R. 2 W., S.L.B.&M.
Found Weber County Brass Cap Mon.
Dated 1963 in good condition.

Northwest Corner of Section 32,
T. 6 N., R. 2 W., S.L.B.&M.
Found Weber County Brass Cap Mon.
Dated 2003 in good condition.

Permanent street monuments shall be accurately set at points necessary to establish all lines of the street.
Centerline monuments shall be noted on the final plat. WCO 106-4-2(g) & WCO 106-1-8(c)(1)(j).

PLEASE PLACE MONUMENTS ONTO THE PLAT.

The existing location, widths, and other dimensions of all existing or platted buildings within and immediately adjacent (within 30') to the tract to be subdivided. WCO 106-1-5(a)(6)

Future 66' Wide R-O-W

Section Line - Basis of Bearing

South

Street

LEGEND

- Subject Property Line
- Interior Lot Lines
- Adjoining Property Line
- Previous Property Line
- Centerline
- Public Utility Easement (PUE)
- Ditch
- Field Separation Line
- Fence Line (Wire)
- Fence Line (wood or Vinyl)
- Street Monument
- Found rebar set by others
- Set 5/8"x24" Rebar With Cap
- Section Corner

Line #	Bearing & Distance
L1	N 89°15'50" W 6.90'
L2	N 0°41'00" E 16.18'
L3	S 0°34'18" W 16.04'

Michael & Natasha
Nielsen Family Trust
15-086-0027

(C1)	(C2)	(C3)
$\Delta = 18^{\circ}55'11''$ $R = 220.00'$ $L = 72.55'$ $LC = 72.32'$ $S 81^{\circ}16'19'' W$	$\Delta = 28^{\circ}34'44''$ $R = 250.00'$ $L = 124.70'$ $LC = 123.41'$ $N 76^{\circ}26'32'' E$	$\Delta = 28^{\circ}34'44''$ $R = 250.00'$ $L = 124.70'$ $LC = 123.41'$ $S 76^{\circ}26'32'' W$

(C4)	(C5)	(C6)
$\Delta = 17^{\circ}29'29''$ $R = 500.00'$ $L = 152.64'$ $LC = 152.05'$ $N 9^{\circ}25'44'' E$	$\Delta = 10^{\circ}38'07''$ $R = 220.00'$ $L = 40.84'$ $LC = 40.78'$ $N 85^{\circ}24'51'' E$	$\Delta = 17^{\circ}56'37''$ $R = 220.00'$ $L = 68.90'$ $LC = 68.62'$ $N 71^{\circ}07'29'' E$

(C7)	(C8)	(C9)
$\Delta = 28^{\circ}34'44''$ $R = 280.00'$ $L = 139.66'$ $LC = 138.22'$ $S 76^{\circ}26'32'' W$	$\Delta = 9^{\circ}39'33''$ $R = 220.00'$ $L = 37.09'$ $LC = 37.04'$ $S 66^{\circ}58'57'' W$	$\Delta = 28^{\circ}34'44''$ $R = 280.00'$ $L = 139.66'$ $LC = 138.22'$ $N 76^{\circ}26'32'' E$

(C10)	(C11)
$\Delta = 16^{\circ}45'45''$ $R = 530.00'$ $L = 155.06'$ $LC = 154.50'$ $N 9^{\circ}03'52'' E$	$\Delta = 18^{\circ}18'57''$ $R = 470.00'$ $L = 150.25'$ $LC = 149.61'$ $N 9^{\circ}50'28'' E$

A signature block for County Surveyor conforming to state code and county ordinance.
Weber County Surveyor:
I hereby certify that the Weber County Surveyor's Office has reviewed this plat and all conditions for approval by this office have been satisfied. The approval of this plat by the Weber County Surveyor does not relieve the Licensed Land Surveyor who executed this plat from the responsibilities and/or liabilities associated therewith.
Signed this _____ day of _____, 2018.
Weber County Surveyor
WCO 106-1-8(c)(1)(k); WCO 45-4-2(c)

WEBER COUNTY ENGINEER

I hereby certify that the Required Public Improvement Standards and Drawings for this Subdivision Conform with the County Standards and the Amount of the Financial Guarantee is Sufficient for the Installation of these Improvements.
Signed this _____ Day of _____, 2018.

Weber County Engineer

WEBER COUNTY SURVEYOR

I hereby certify that the Weber County Surveyor's Office has Reviewed this Plat for Mathematical Correctness, Section Corner Data, and for Harmony with the Lines and Monuments on Record in County Offices. The Approval of this Plat by the Weber County Surveyor does not Relieve the Licensed Land Surveyor who Executed this Plat from the Responsibilities and/or Liabilities Associated Therewith. Signed this _____ Day of _____, 2018.

Weber County Surveyor

AGRICULTURAL NOTE

Agriculture is the preferred use in the Agriculture Zones. Agriculture operations as specified in the zoning ordinance for a particular zone are permitted at any time including the operation of farm machinery and no allowed agriculture use shall be subject to restriction on that it interferes with activities of future residents of this subdivision

All Public Utility Easements are 10.0' Wide Unless Noted Otherwise.

Rebar w/HAL cap or curb nail set on all Property Corners.

Developer:
Blackburn Jones
905 24th Street
Ogden, Utah 84404
(801) 776-0068



HANSEN & ASSOCIATES, INC.
Consulting Engineers and Land Surveyors
538 North Main Street, Brigham, Utah 84302
Visit us at www.hais.net
Brigham City Ogden Logan
(435) 723-3491 (801) 399-4905 (435) 752-8272

NARRATIVE

The Purpose of this Survey was to Establish and set the Property Corners of the 11 Lot Subdivision as Shown and Described Hereon. This Survey was Ordered by Carson Jones of Blackburn Jones. The POB for this Subdivision is on the projection of the west boundary line of the Nielsen Acres Subdivision. The new south right-of-way line of 2550 South Street is that which seems to fit in best harmony for a future 66' wide right-of-way. Said south right-of-way line does not line up with that as platted on the Nielsen Acres Subdivision. The Control used to Establish the Property Corners was the Existing Weber County Surveyor Monumentation Surrounding Section 32, Township 6 North, Range 2 West, S.L.B.&M. The basis of bearing is the North line of the Northwest Quarter of said Section which bears North 89°06'33" West, Utah North, State Plane, Calculated N.A.D.83 Bearing.

WEBER COUNTY COMMISSION ACCEPTANCE

This is to Certify that this Subdivision Plat, the Dedication of Streets and other Public Ways and Financial Guarantee of Public Improvements Associated with this Subdivision, Thereon are Hereby Approved and Accepted by the Commissioners of Weber County Utah
Signed this _____ Day of _____, 2018.

Chairman, Weber County Commission

AHest

WEBER COUNTY PLANNING COMMISSION APPROVAL

This is to Certify that this Subdivision Plat was Duly Approved by the Weber County Planning Commission.
Signed this _____ Day of _____, 2018.

Chairman, Weber County Planning Commission

WEBER COUNTY ATTORNEY

I Have Examined the Financial Guarantee and Other Documents Associated with this Subdivision Plat, and in my Opinion they Conform with the County Ordinance Applicable Thereto and now in Force and Affect
Signed this _____ Day of _____, 2018.

Weber County Attorney

WEBER-MORGAN HEALTH DEPARTMENT

I hereby Certify that the Soils, Percolation Rates, and Site Conditions for this Subdivision have been Investigated by this Office and are Approved for On-Site Wastewater Disposal Systems.
Signed this _____ Day of _____, 2018.

Weber-Morgan Health Department

SURVEYOR'S CERTIFICATE

I, K. Greg Hansen, do hereby Certify that I am a Registered Professional Land Surveyor in the State of Utah in Accordance with Title 58, Chapter 22, Professional Engineers and Land Surveyors Act; and I have completed a Survey of the property described on this plat in accordance with Section 17-23-17 and have verified all measurements, and have placed monuments as represented on this plat, and have hereby Subdivided said tract into eleven (11) lots, known hereafter as Sun Crest Meadows Subdivision in Weber County, Utah, and has been correctly drawn to the designated scale and is true and correct representation of the herein described lands included in said Subdivision, based upon data compiled from records in the Weber County Recorder's Office and from said survey made by me or under my supervision on the ground. I further hereby certify that the requirements of all applicable statutes and ordinances of Weber County concerning Zoning Requirements regarding lot measurements have been complied with.

Signed this _____ day of _____, 2018.

K. Greg Hansen P.L.S.
Utah Land Surveyor Licence No. 167819



BOUNDARY DESCRIPTION

A PART OF THE NORTHWEST QUARTER OF SECTION 32, TOWNSHIP 6 NORTH, RANGE 2 WEST OF THE SALT LAKE BASE AND MERIDIAN.

BEGINNING AT A POINT ON THE EXISTING SOUTH RIGHT-OF-WAY LINE OF 2550 SOUTH STREET LOCATED 807.96 FEET NORTH 89°06'33" WEST ALONG THE NORTH LINE OF SAID NORTHWEST QUARTER AND 23.55 FEET SOUTH 00°34'18" WEST FROM THE NORTHEAST CORNER OF SAID SECTION NORTHWEST QUARTER;

RUNNING THENCE SOUTH 00°34'18" WEST 279.45 FEET ALONG THE WEST BOUNDARY LINE OF NIELSEN ACRES SUBDIVISION FILED AS ENTRY NO. 1637888 IN THE FILES OF THE WEBER COUNTY RECORDER TO THE SOUTHWEST CORNER OF SAID NIELSEN ACRES SUBDIVISION; THENCE SOUTH 89°06'33" EAST 233.82 FEET ALONG THE SOUTH BOUNDARY LINE OF SAID NIELSEN ACRES SUBDIVISION; THENCE SOUTH 00°41'00" WEST 232.19 FEET; THENCE NORTH 89°15'50" WEST 6.92 FEET; THENCE TO THE LEFT ALONG THE ARC OF A 220.00 FOOT RADIUS CURVE, A DISTANCE OF 72.65 FEET, CHORD BEARS SOUTH 81°16'19" WEST 72.32 FEET, HAVING A CENTRAL ANGLE OF 18°55'11"; THENCE SOUTH 00°43'54" WEST 246.66 FEET; THENCE NORTH 89°19'00" WEST 406.46 FEET; THENCE NORTH 84°30'36" WEST 61.51 FEET; THENCE NORTH 89°19'00" WEST 267.01 FEET; THENCE NORTH 09°58'17" EAST 149.66 FEET; THENCE NORTH 00°41'00" EAST 615.75 FEET TO SAID EXISTING SOUTH RIGHT-OF-WAY LINE; THENCE SOUTH 89°33'42" EAST 554.73 FEET ALONG SAID EXISTING SOUTH RIGHT-OF-WAY LINE TO THE POINT OF BEGINNING. CONTAINING 11.997 ACRES.

OWNER'S DEDICATION AND CERTIFICATION

Know all men by these presents that we, the undersigned Owners of the above described tract of land having caused the same to be subdivided into lots and streets, as shown on this plat and name said tract Sun Crest Meadows Subdivision Phase 1 and hereby dedicates, grant and convey, in perpetuity, pursuant to the provisions of 17-27a-607, Utah code, without condition, restriction or reservation to Weber County, Utah, all those parts or portions of said tract of land designated as streets the same to be used as public thoroughfares forever, and also dedicate to Weber County those certain strips as easements for public utility and drainage purposes as shown hereon. The same to be used for the installation, maintenance and operation of public utility service lines and drainage as may be authorized by the Governing Authority in witness we have here unto set our signature this _____ day of _____, 2018.

Reed D. Wight Trustee
of the Wight Family Revocable Trust

Velda H. Wight Trustee

Michael Nielsen Joint Tenant
of the Michael and Natasha Nielsen Family Trust

Natasha M. Nielsen Joint Tenant

TRUST ACKNOWLEDGMENT

State of Utah
County of Weber

On this _____ day of _____, 20__.

Reed D. Wight and Velda H. Wight, Trustees of the Wight Family Revocable Trust, personally appeared before me, the undersigned notary public in and for said county, in the state of Utah, the signers of the attached owners dedication, two in numbers, who duly acknowledged to me they signed it freely and voluntarily and for the purpose therein mentioned on behalf of said trust.

Notary public

TRUST ACKNOWLEDGMENT

State of Utah
County of Weber

On this _____ day of _____, 20__.

Michael Nielsen and Natasha M. Nielsen as joint tenants of the Michael and Natasha Nielsen Family Trust, personally appeared before me, the undersigned notary public in and for said county, in the state of Utah, the signers of the attached owners dedication, two in numbers, who duly acknowledged to me they signed it freely and voluntarily and for the purpose therein mentioned on behalf of said trust.

Notary public

WEBER COUNTY RECORDER

ENTRY NO. _____ FEE PAID _____

FILED FOR RECORD AND

RECORDED _____

IN BOOK _____ OF OFFICIAL

RECORDS, PAGE _____ RECORDED

FOR _____

COUNTY RECORDER

BY: _____

DEPUTY

Sun Crest Meadows Subdivision Phase 1

Weber County, Utah

A Part of the Northwest Quarter of Section 32,
Township 6 North, Range 2 West, Salt Lake Base & Meridian

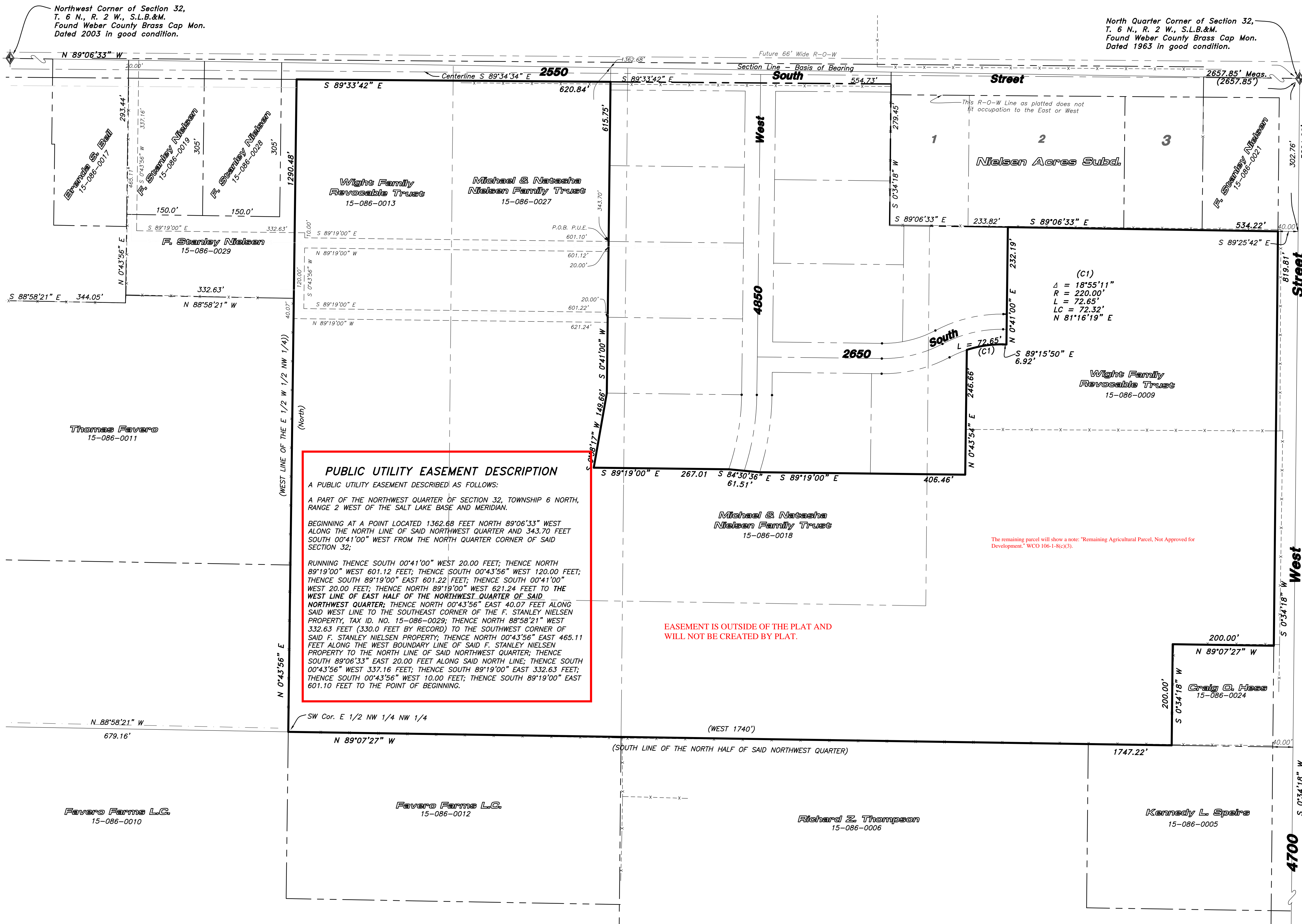

SURVEYOR'S CERTIFICATE

I, K. Greg Hansen, do hereby certify that I am a Registered Professional Land Surveyor in the State of Utah in accordance with Title 58, Chapter 22, Professional Engineers and Land Surveyors Act; and I have completed a Survey of the property described on this plat in accordance with Section 17-23-17 and have verified all measurements, and have placed monuments as represented on this plat, and have hereby subdivided said tract into eleven (11) lots, known hereafter as Sun Crest Meadows Subdivision in Weber County, Utah, and has been correctly drawn to the designated scale and is true and correct representation of the herein described lands included in said Subdivision, based upon data compiled from records in the Weber County Recorder's Office and from said survey made by me or under my supervision on the ground, I further hereby certify that the requirements of all applicable statutes and ordinances of Weber County Concerning Zoning Requirements regarding lot measurements have been complied with.

Signed this _____ day of _____, 2017.

K. Greg Hansen P.L.S.
Utah Land Surveyor Licence No. 167819

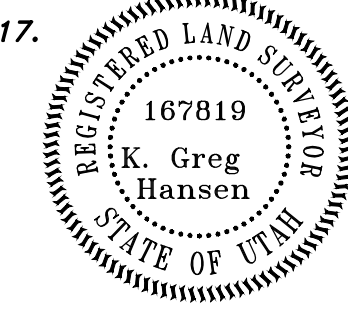

BOUNDARY DESCRIPTION

A PART OF THE NORTHWEST QUARTER OF SECTION 32, TOWNSHIP 6 NORTH, RANGE 2 WEST OF THE SALT LAKE BASE AND MERIDIAN.

BEGINNING AT THE SOUTHEAST CORNER OF THE F. STANLEY NIELSEN PROPERTY FILED AS ENTRY NO. 2822142 IN THE WEBER COUNTY RECORDER OFFICE, BEING A POINT LOCATED 302.76 FEET SOUTH 00°34'18" WEST ALONG THE EAST LINE OF SAID NORTHWEST QUARTER AND 40.00 FEET NORTH 89°25'42" WEST FROM THE NORTHEAST CORNER OF SAID NORTHWEST QUARTER;

RUNNING THENCE SOUTH 00°34'18" WEST 819.81 FEET (817 FEET BY RECORD) ALONG SAID WEST RIGHT-OF-WAY LINE TO THE NORTHEAST PROPERTY CORNER OF THE CRAIG O. HESS PROPERTY, FILED AS ENTRY NO. 1122274 IN THE FILES OF THE WEBER COUNTY RECORDER; THENCE ALONG THE BOUNDARY LINE OF SAID HESS PROPERTY THE FOLLOWING TWO (2) COURSES; (1) NORTH 89°07'27" WEST 200.00 FEET; AND (2) SOUTH 00°34'18" WEST 200.00 FEET TO THE SOUTH LINE OF THE NORTH HALF OF SAID NORTHWEST QUARTER BEING A POINT ON THE NORTH BOUNDARY LINE OF THE KENNEDY L. SPEIRS PROPERTY, FILED AS ENTRY NO. 2814936; THENCE NORTH 89°07'27" WEST 1747.22 FEET (WEST 1740 FEET BY RECORD) ALONG SAID SOUTH BOUNDARY LINE TO THE SOUTHWEST CORNER OF THE EAST HALF OF THE NORTHWEST QUARTER OF SAID NORTHWEST QUARTER; THENCE NORTH 00°43'56" EAST 1290.48 FEET ALONG THE WEST LINE OF SAID EAST HALF TO THE SOUTH RIGHT-OF-WAY LINE OF 2550 SOUTH STREET; THENCE ALONG SAID SOUTH RIGHT-OF-WAY LINE SOUTH 89°33'42" EAST 620.84 FEET; THENCE SOUTH 00°41'00" WEST 615.75 FEET; THENCE SOUTH 09°58'17" WEST 149.66 FEET; THENCE SOUTH 89°19'00" EAST 267.01 FEET; THENCE SOUTH 84°30'36" EAST 61.51 FEET; THENCE SOUTH 89°19'00" EAST 406.46 FEET; THENCE NORTH 00°43'54" EAST 246.66 FEET; THENCE IN AN EASTERLY DIRECTION TO THE RIGHT OF A NON-TANGENT 220.00 FOOT CURVE, A DISTANCE OF 72.65 FEET, CHORD BEARS NORTH 81°16'19" EAST 72.32 FEET, HAVING A CENTRAL ANGLE OF 18°55'11"; THENCE SOUTH 89°15'50" EAST 6.92 FEET; THENCE NORTH 00°41'00" EAST 232.19 FEET TO THE SOUTH BOUNDARY LINE OF NIELSEN ACRES SUBDIVISION FILED AS ENTRY NO. 1637888; THENCE ALONG THE SOUTH BOUNDARY LINE OF SAID NIELSEN ACRES SUBDIVISION AND THEN SAID F. STANLEY NIELSEN PROPERTY SOUTH 89°06'33" EAST 534.22 FEET TO THE POINT OF BEGINNING. CONTAINING 40.07 ACRES.

PUBLIC UTILITY EASEMENT DESCRIPTION
A PUBLIC UTILITY EASEMENT DESCRIBED AS FOLLOWS:
A PART OF THE NORTHWEST QUARTER OF SECTION 32, TOWNSHIP 6 NORTH, RANGE 2 WEST OF THE SALT LAKE BASE AND MERIDIAN.
BEGINNING AT A POINT LOCATED 1362.68 FEET NORTH 89°06'33" WEST ALONG THE NORTH LINE OF SAID NORTHWEST QUARTER AND 343.70 FEET SOUTH 00°41'00" WEST FROM THE NORTH QUARTER CORNER OF SAID SECTION 32;
RUNNING THENCE SOUTH 00°41'00" WEST 20.00 FEET; THENCE NORTH 89°19'00" WEST 601.12 FEET; THENCE SOUTH 00°43'56" WEST 120.00 FEET; THENCE SOUTH 89°19'00" EAST 601.22 FEET; THENCE SOUTH 00°41'00" WEST 20.00 FEET; THENCE NORTH 89°19'00" WEST 621.24 FEET TO THE WEST LINE OF EAST HALF OF THE NORTHWEST QUARTER OF SAID NORTHWEST QUARTER; THENCE NORTH 00°43'56" EAST 40.07 FEET ALONG SAID WEST LINE TO THE SOUTHEAST CORNER OF THE F. STANLEY NIELSEN PROPERTY, TAX ID. NO. 15-086-0029; THENCE NORTH 88°58'21" WEST 332.63 FEET (330.0 FEET BY RECORD) TO THE SOUTHWEST CORNER OF SAID F. STANLEY NIELSEN PROPERTY; THENCE NORTH 00°43'56" EAST 465.11 FEET ALONG THE WEST BOUNDARY LINE OF SAID F. STANLEY NIELSEN PROPERTY TO THE NORTH LINE OF SAID NORTHWEST QUARTER; THENCE SOUTH 89°06'33" EAST 20.00 FEET ALONG SAID NORTH LINE; THENCE SOUTH 00°43'56" WEST 337.16 FEET; THENCE SOUTH 89°19'00" EAST 332.63 FEET; THENCE SOUTH 00°43'56" WEST 10.00 FEET; THENCE SOUTH 89°19'00" EAST 601.10 FEET TO THE POINT OF BEGINNING.

EASEMENT IS OUTSIDE OF THE PLAT AND WILL NOT BE CREATED BY PLAT.

The remaining parcel will show a note: "Remaining Agricultural Parcel, Not Approved for Development." WCO 106-1-8(c)(3).

- LEGEND**
- Subject Property Line
 - - - Interior Lot Lines
 - - - Adjoining Property Line
 - - - Previous Property Line
 - - - Centerline
 - - - Public Utility Easement (PUE)
 - - - Ditch
 - - - Field Separation Line
 - - - Fence Line (Wire)
 - - - Fence Line (wood or Vinyl)
 - - - Street Monument
 - - - Found rebar set by others
 - - - Set 5/8"x24" Rebar With Cap
 - - - Section Corner

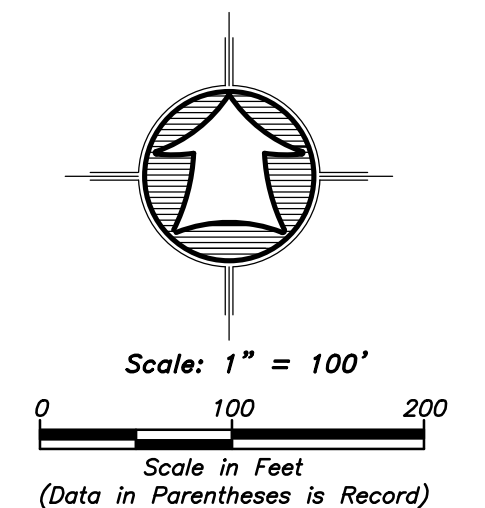

WEBER COUNTY RECORDER

ENTRY NO. _____ FEE PAID _____
 _____ FILED FOR RECORD AND
 RECORDED _____
 _____ IN BOOK _____ OF OFFICIAL
 RECORDS, PAGE _____ RECORDED
 FOR _____
 _____ COUNTY RECORDER
 BY: _____ DEPUTY

HAI
HANSEN & ASSOCIATES, INC.
 Consulting Engineers and Land Surveyors
 538 North Main Street, Brigham, Utah 84302
 Visit us at www.haies.net
 Brigham City Ogden Logan
 (435) 723-3491 (801) 399-4905 (435) 752-8272