

# SUN CREST MEADOWS SUBDIVISION PHASE 1

## OFF-SITE SEWER PLAN & PROFILE

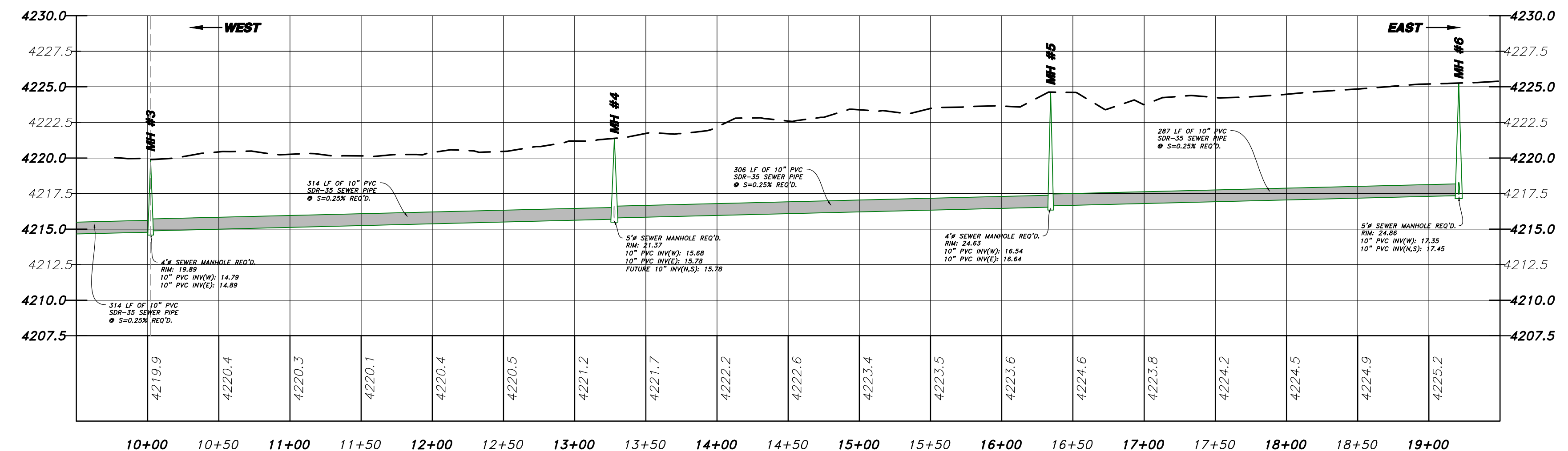
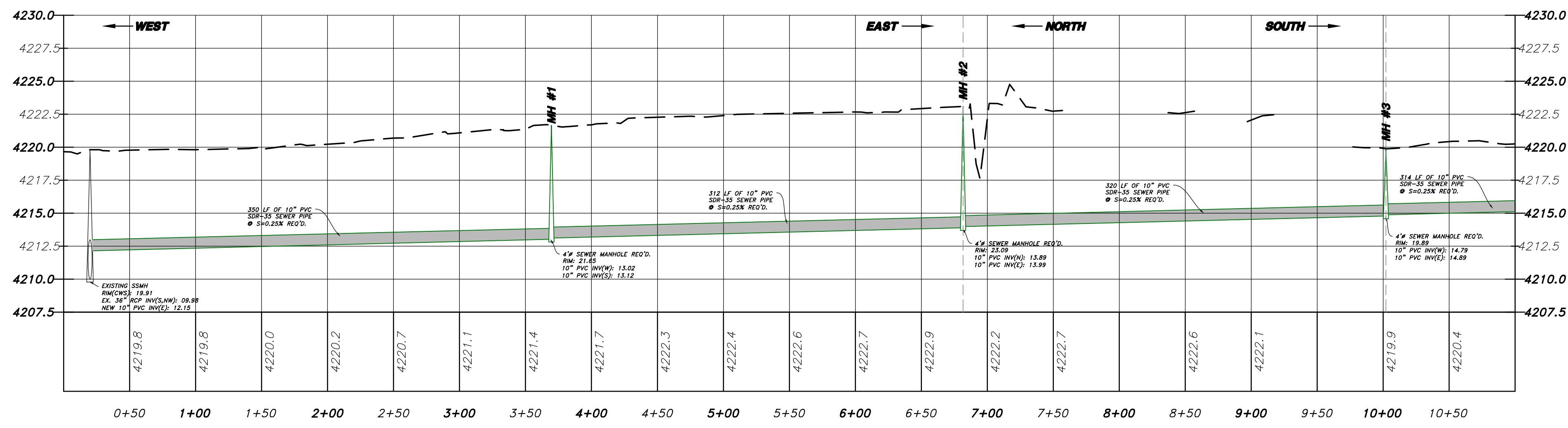
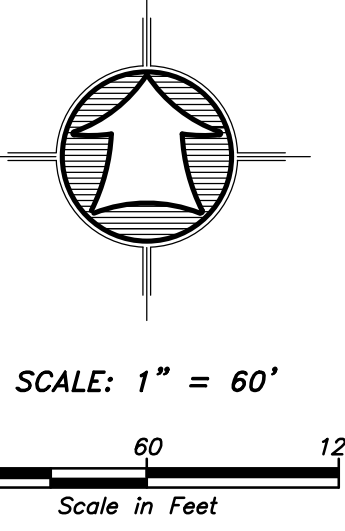
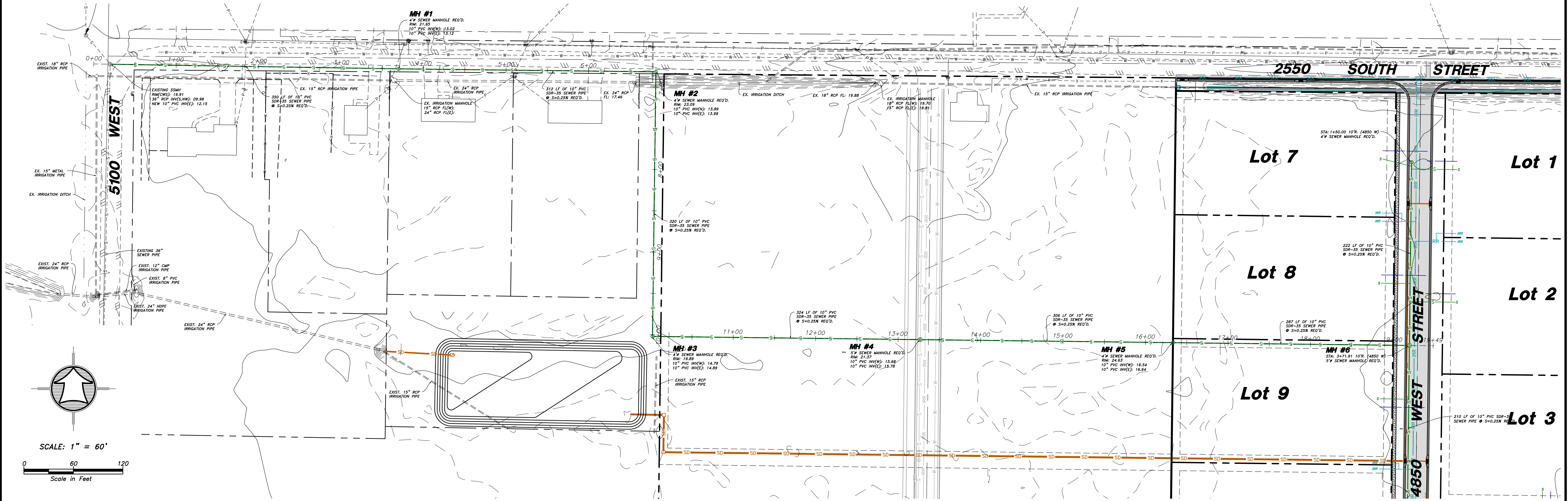

<p>Drawn By: MTH Date: 05/01/18</p> <p>Designed By: _____</p> <p>Checked By: _____</p> <p>Approved By: _____</p> <p>Scale: 1" = 60'</p> <p>Drawing File: 16-105-18(05-01-18)</p> <p>JOB NUMBER: 16-105</p>	<p style="text-align: center;">Hansen &amp; Associates, Inc.</p> <p style="text-align: center;">Consulting Engineers and Land Surveyors</p> <p style="text-align: center;">538 North Main Street, Brigham, Utah 84302</p> <p style="text-align: center;">Visit us at <a href="http://www.hansen.net">www.hansen.net</a></p> <p style="text-align: center;">Logan Ogden Brigham City 391 (801) 399-4905 (435) 752-8272</p>						
<p><b>SUN CREST MEADOWS SUBDIVISION PHASE 1</b></p> <p>OFF-SITE SEWER PLAN &amp; PROFILE</p> <p>2550 NORTH 4900 WEST TAYLOR, UT 84401</p>							
<p>Sheet</p> <p style="font-size: 2em;"><b>3</b></p> <p>of</p> <p style="font-size: 2em;"><b>12</b></p> <p>Sheets</p>	<table border="1" style="width: 100%; border-collapse: collapse;"> <tr> <td style="width: 50%;">No.</td> <td style="width: 50%;">Date</td> <td style="width: 50%;">By</td> </tr> <tr> <td>12/27/17</td> <td></td> <td></td> </tr> </table> <p style="font-size: 8px; text-align: right;">UPDATE WATER NOTES PER STANDARDS</p>	No.	Date	By	12/27/17		
No.	Date	By					
12/27/17							

# SUN CREST MEADOWS SUBDIVISION PHASE 1

## OFF-SITE SEWER PLAN & PROFILE

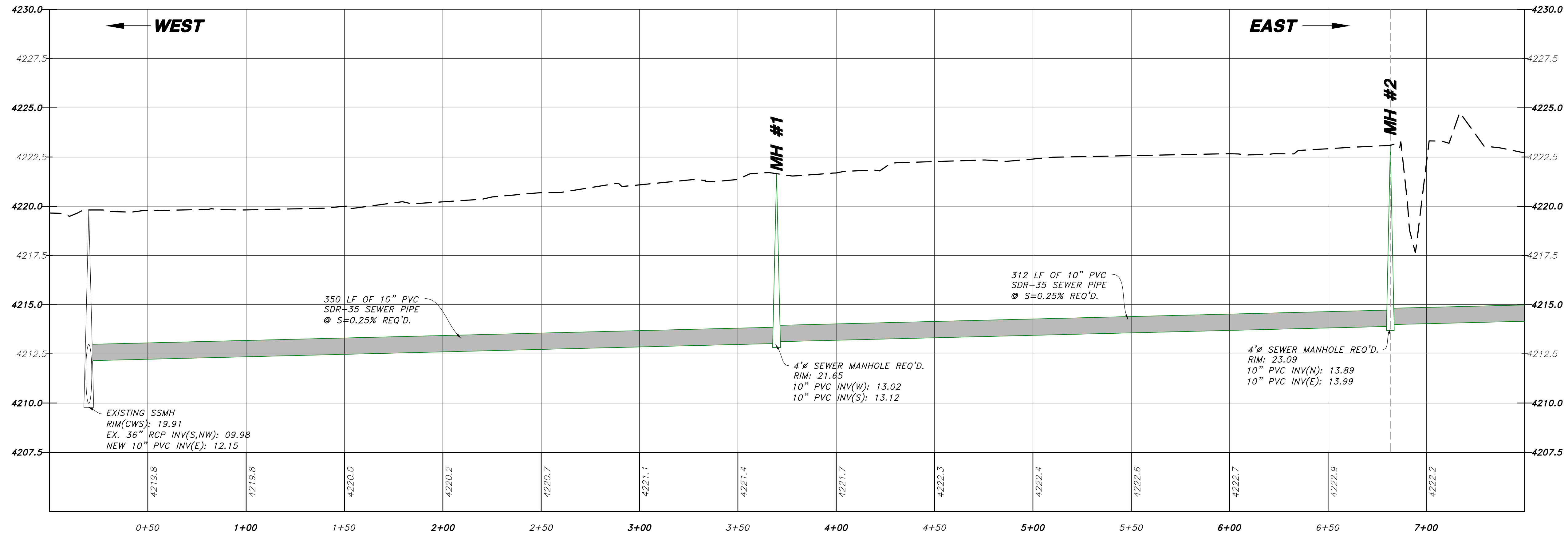
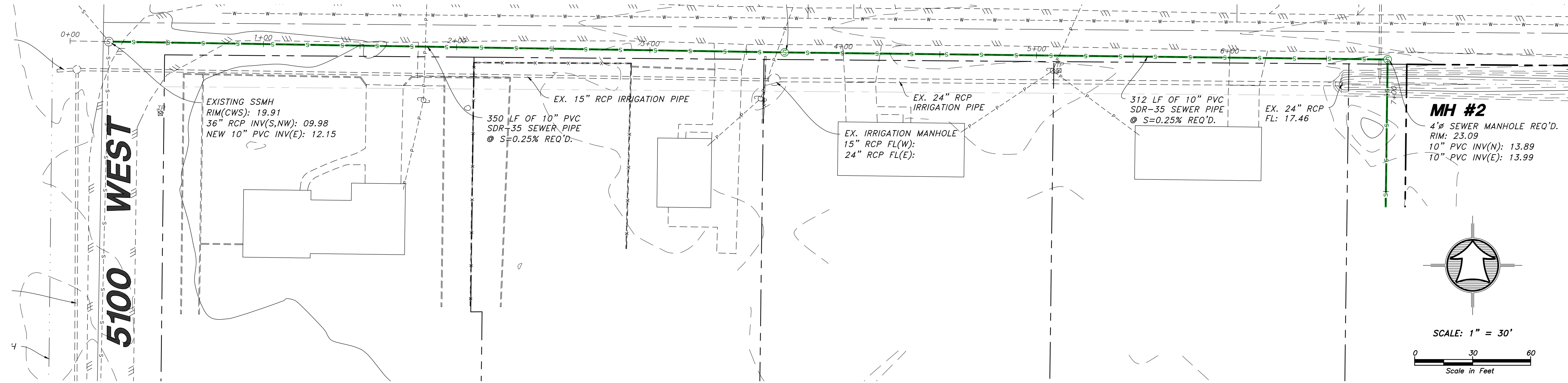

**HANSEN & ASSOCIATES, INC.**  
Consulting Engineers and Land Surveyors  
538 North Main Street, Brigham, Utah 84302  
Visit us at [www.hanes.net](http://www.hanes.net)  
Logan  
Brigham City    (801) 399-4905    (435) 752-8272  
(435) 723-3491



Drawn By: MTH    Date: 05/01/18  
Designed By:  
Checked By:  
Approved By:  
Scale: 1" = 30'  
Drawing File: 16-105/18(05-01-18)  
JOB NUMBER: 16-105

OFF-SITE SEWER PLAN & PROFILE  
**SUN CREST MEADOWS  
SUBDIVISION PHASE 1**  
2550 NORTH 4900 WEST  
TAYLOR, UT 84401

Sheet

**3A**

of

**12**

Sheets

No.	Date	By	Revision
1	12/27/17	MTH	UPDATE WATER NOTES PER STANDARDS

**SUN CREST MEADOWS SUBDIVISION PHASE 1**  
OFF-SITE SEWER PLAN & PROFILE

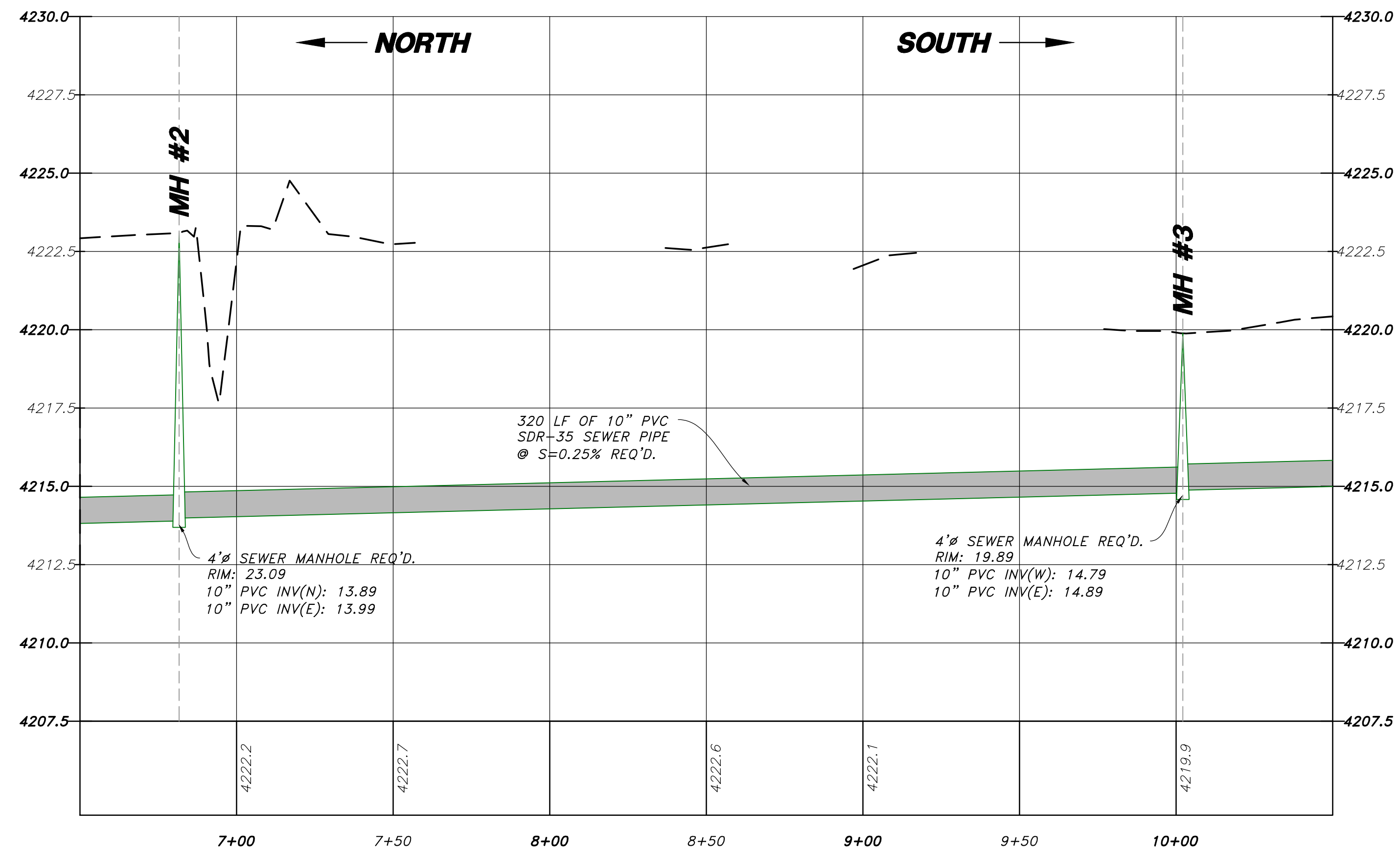
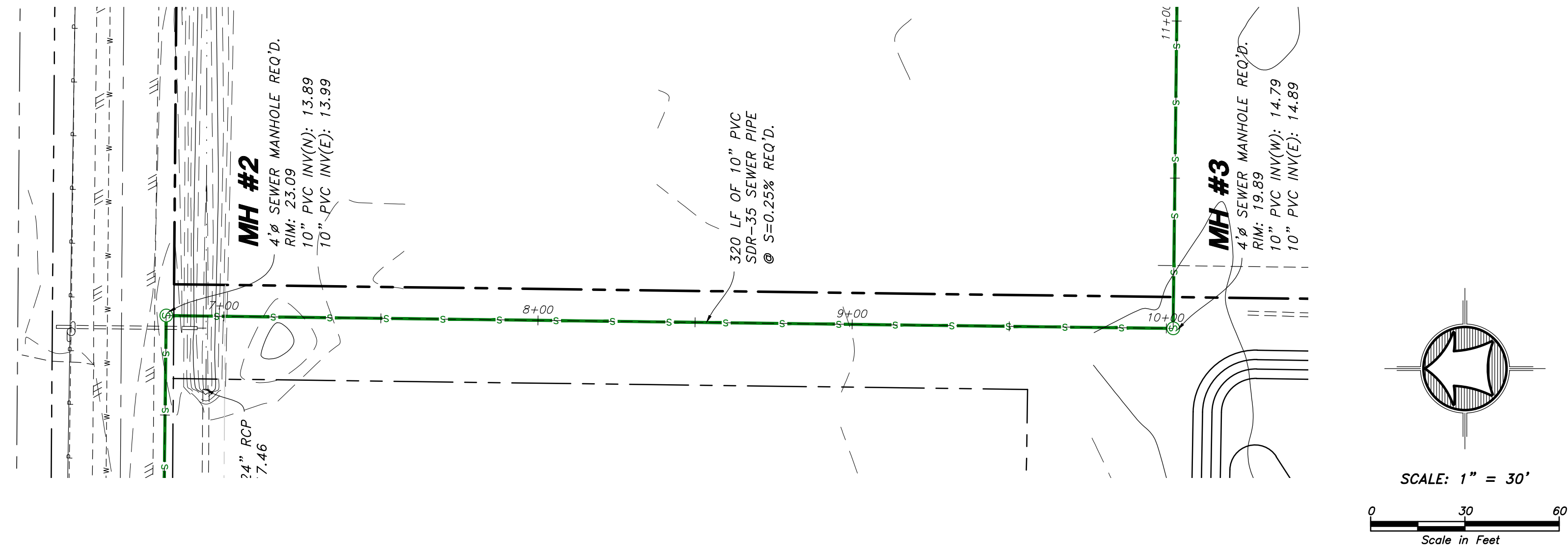

No.	Date	By
1	12/27/17	MTH

UPDATE WATER NOTES PER STANDARDS

**HANSEN & ASSOCIATES, INC.**  
 Consulting Engineers and Land Surveyors  
 538 North Main Street, Brigham, Utah 84302  
 Visit us at [www.haies.net](http://www.haies.net)  
 Logan, Utah  
 (435) 723-3491 (801) 399-4905 (435) 752-8272



Drawn By: MTH Date: 05/01/18  
 Designed By:  
 Checked By:  
 Approved By:  
 Scale: 1" = 30'  
 Drawing File: 16-105/18(05-01-18)  
 JOB NUMBER: 16-105

OFF-SITE SEWER PLAN & PROFILE  
**SUN CREST MEADOWS SUBDIVISION PHASE 1**  
 2550 NORTH 4900 WEST  
 TAYLOR, UT 84401

# SUN CREST MEADOWS SUBDIVISION PHASE 1

## OFF-SITE SEWER PLAN & PROFILE

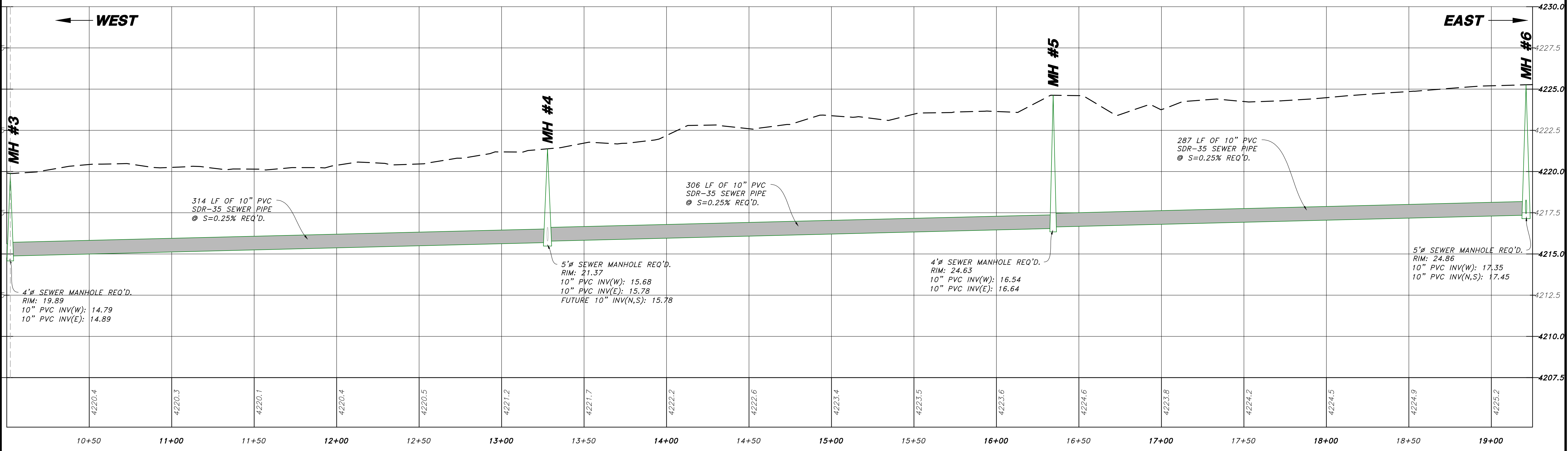
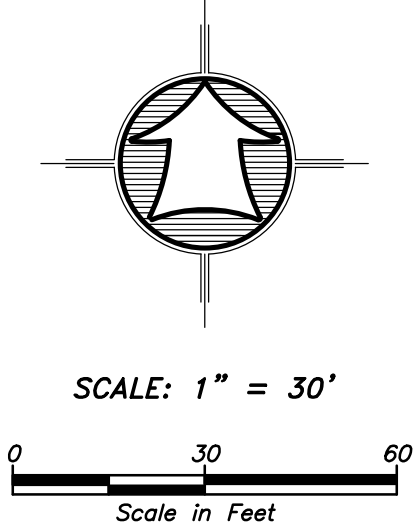
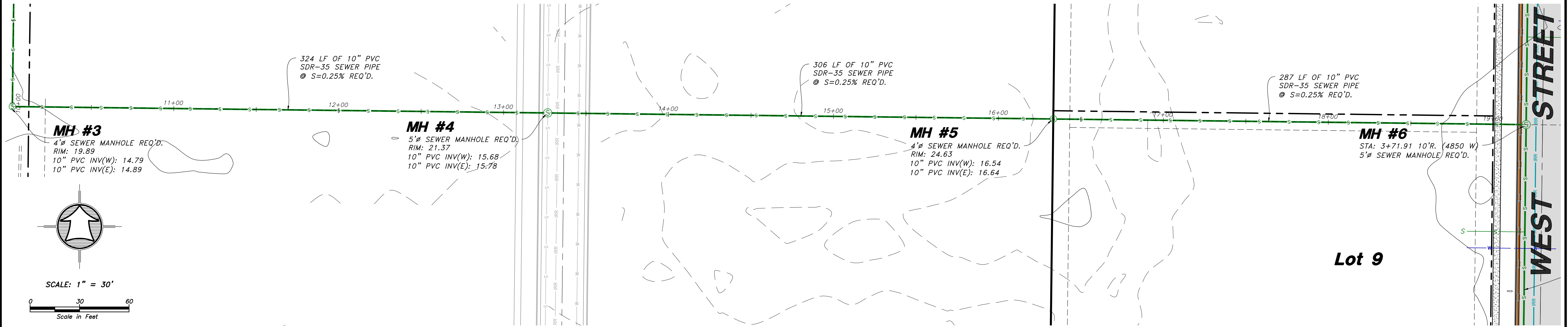

No.	Date	By	Revision
1	12/27/17	MTH	UPDATE WATER NOTES PER STANDARDS

**HANSEN & ASSOCIATES, INC.**  
Consulting Engineers and Land Surveyors  
538 North Main Street, Brigham, Utah 84302  
Visit us at [www.hansen.net](http://www.hansen.net)  
Logan  
Brigham City Ogden  
(435) 723-3491 (801) 399-4905 (435) 752-8272



Drawn By: MTH Date: 05/01/18  
Designed By:  
Checked By:  
Approved By:  
Scale: 1" = 30'  
Drawing File: 16-105/18(05-01-18)  
JOB NUMBER: 16-105

OFF-SITE SEWER PLAN & PROFILE  
**SUN CREST MEADOWS SUBDIVISION PHASE 1**  
2550 NORTH 4900 WEST  
TAYLOR, UT 84401