

# TAYLOR VISTA SUBD.

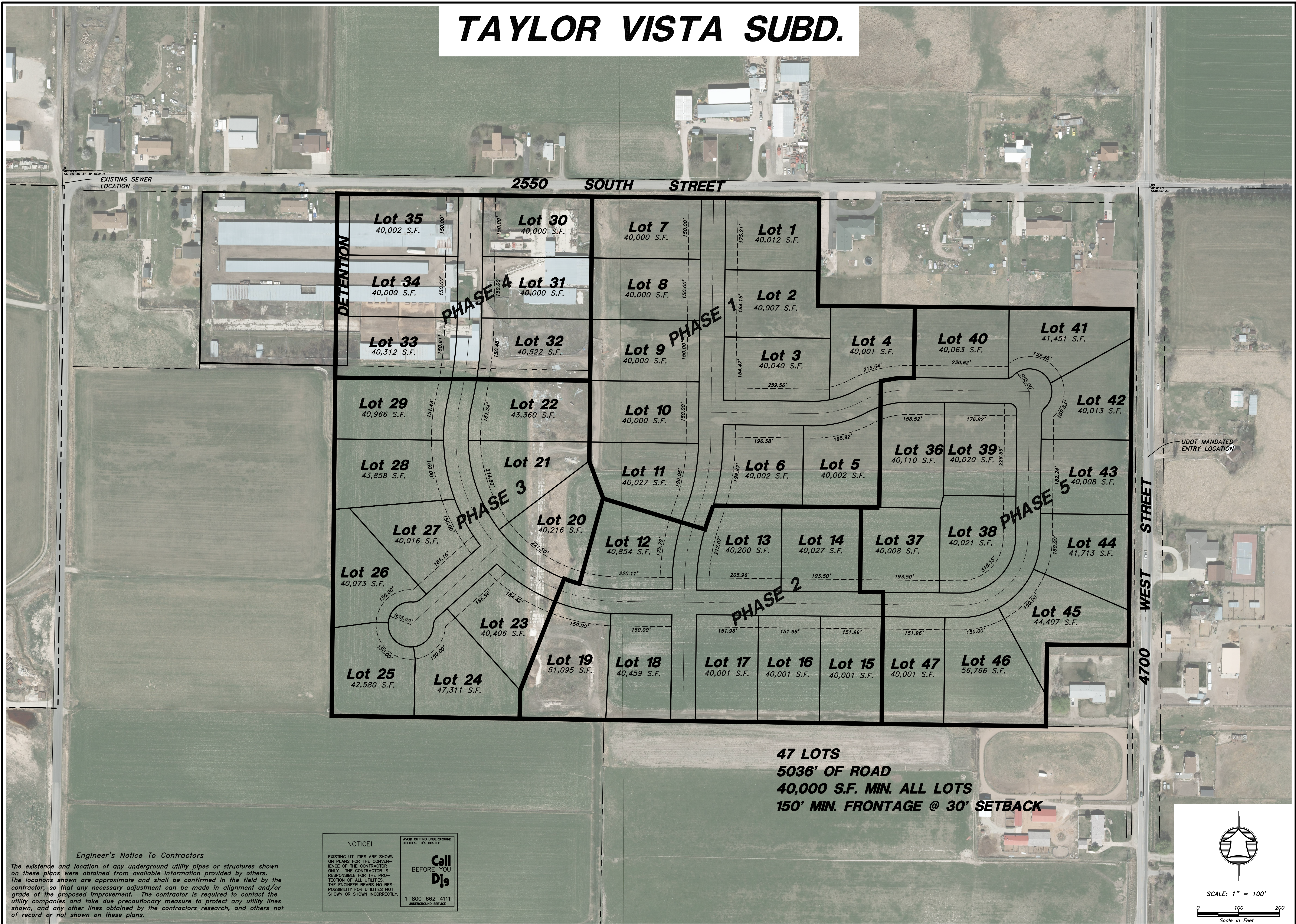

**47 LOTS**  
**5036' OF ROAD**  
**40,000 S.F. MIN. ALL LOTS**  
**150' MIN. FRONTAGE @ 30' SETBACK**

**Engineer's Notice To Contractors**

The existence and location of any underground utility pipes or structures shown on these plans were obtained from available information provided by others. The locations shown are approximate and shall be confirmed in the field by the contractor, so that any necessary adjustment can be made in alignment and/or grade of the proposed improvement. The contractor is required to contact the utility companies and take due precautionary measure to protect any utility lines shown, and any other lines obtained by the contractors research, and others not of record or not shown on these plans.

**NOTICE!**

EXISTING UTILITIES ARE SHOWN ON PLANS FOR THE CONVENIENCE OF THE CONTRACTOR ONLY. THE CONTRACTOR IS RESPONSIBLE FOR THE PROTECTION OF ALL UTILITIES. THE ENGINEER BEARS NO RESPONSIBILITY FOR UTILITIES NOT SHOWN OR SHOWN INCORRECTLY.

**Call BEFORE YOU Dig**

1-800-662-4111  
 UNDERGROUND SERVICE

CONCEPT PLAN FOR	
<b>TAYLOR VISTA SUBD.</b>	
<b>OPTION #10</b>	
A Part of the Southeast Quarter of Section 2 Township 10 North, Range 2 West, S.L.B.&M.	
Drawn By: MBJ	Date: 10/26/2016
Designed By:	
Checked By:	
Approved By:	
Scale: 1" = 100'	
Drawing File: 16-105 OPT 10.DWG	
Client: Hansen & Associates, Inc.	
Job Number: 16-105	
No.	Date
By	
Revision	

**HANSEN & ASSOCIATES, INC.**  
 Consulting Engineers and Land Surveyors  
 558 North Main Street, Brigham, Utah 84302  
 Brigham, UT at [www.hais.net](http://www.hais.net)  
 (435) 733-5491 (801) 399-6605 (435) 732-8272



Drawn By: MBJ Date: 10/26/2016  
 Designed By:  
 Checked By:  
 Approved By:  
 Scale: 1" = 100'  
 Drawing File: 16-105 OPT 10.DWG  
 Client: Hansen & Associates, Inc.  
 Job Number: 16-105

**TAYLOR VISTA SUBD.**  
**OPTION #10**  
 A Part of the Southeast Quarter of Section 2  
 Township 10 North, Range 2 West, S.L.B.&M.

Sheet  
**1**  
 of  
**1**  
 Sheets

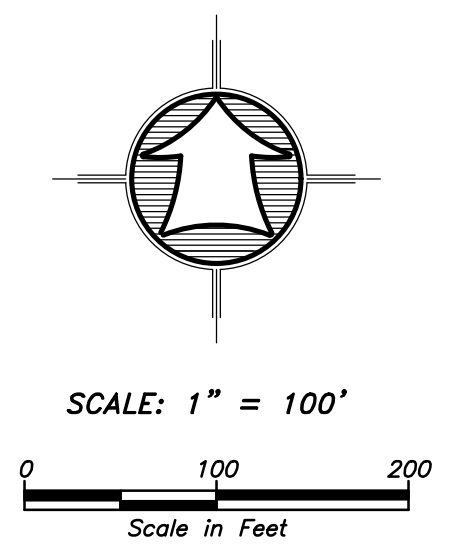

N:\2016\16-105 Carson Jones - Taylor Subd\drawings\16-105 v15 opt 10.dwg, 10/26/2016 5:00:26 PM, DWG To PDF.pc3