

# THE RIDGE TOWNHOMES PHASE 3

A PLANNED RESIDENTIAL UNIT DEVELOPMENT (P.R.U.D.)

PART OF THE NORTHEAST 1/4 OF SECTION 27

T7N, R1E, SLB & M, US SURVEY

WEBER COUNTY, UTAH

SEPTEMBER 2016

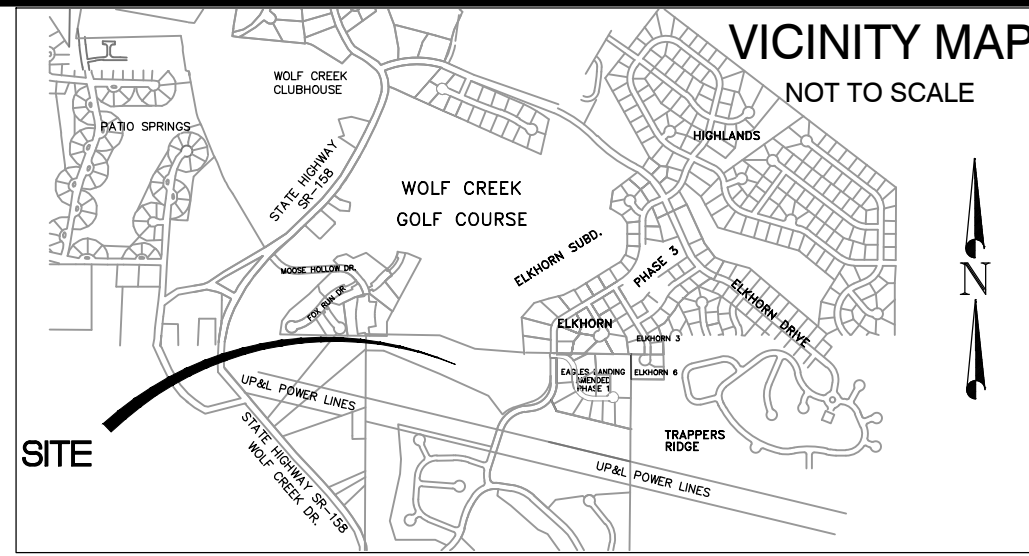

NORTHWEST CORNER OF NORTHEAST QUARTER OF SECTION 27, T7N, R1E, SLB&M (WEBER CO. BRASS CAP - 1981, GOOD COND)

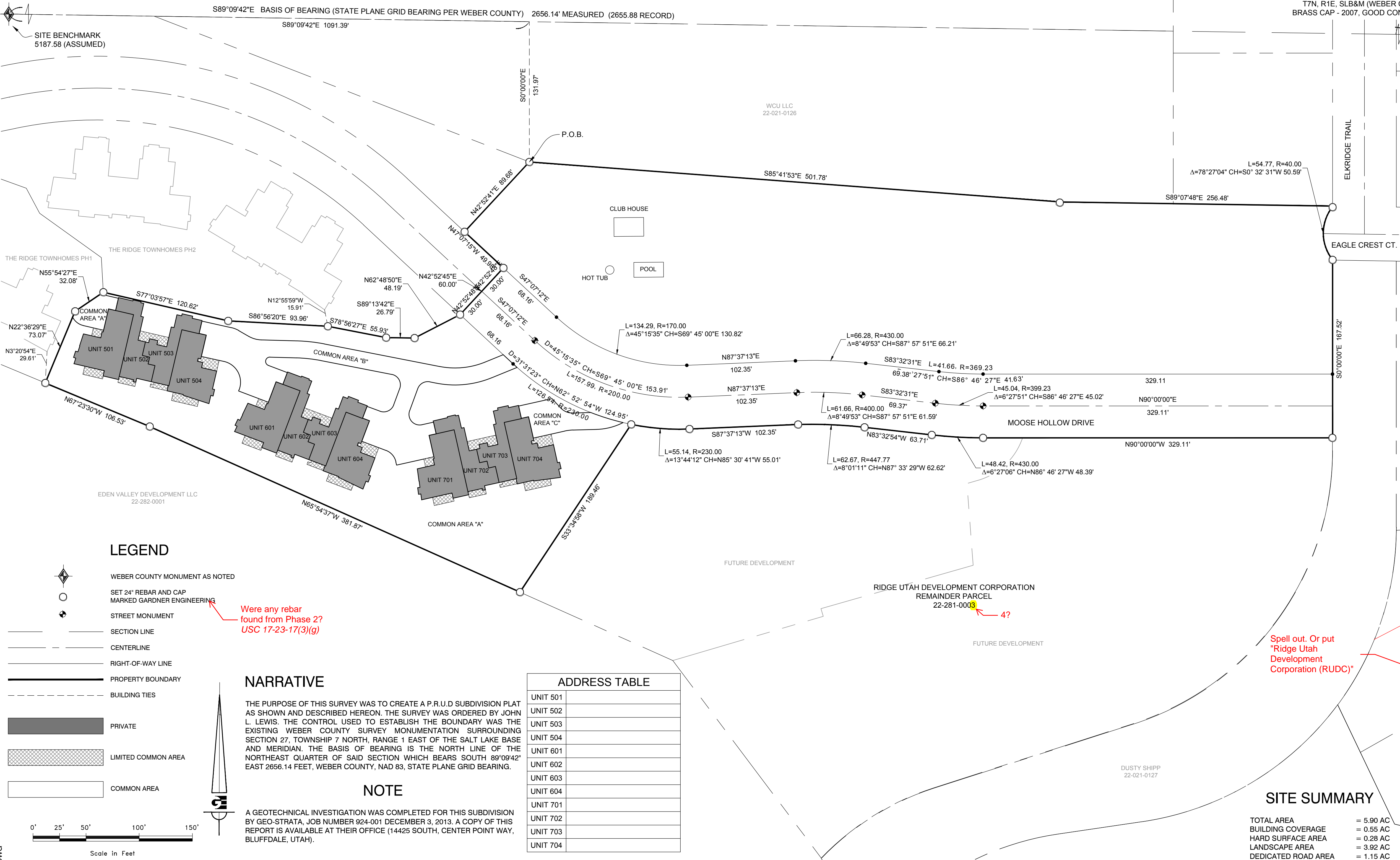

### BOUNDARY DESCRIPTION

A PART OF THE NORTHEAST QUARTER OF SECTION 27, TOWNSHIP 7 NORTH, RANGE 1 EAST OF THE SALT LAKE BASE AND MERIDIAN, MORE PARTICULARLY DESCRIBED AS FOLLOWS:  
 BEGINNING AT THE NORTHEASTERLY MOST CORNER OF THE RIDGE TOWNHOMES PHASE 1 BEING LOCATED SOUTH 89°09'42" EAST 1091.39 FEET ALONG THE NORTH LINE OF SAID NORTHEAST QUARTER AND SOUTH 0°00'00" EAST 131.97 FEET FROM THE NORTHWEST CORNER OF SAID NORTHEAST QUARTER; RUNNING THENCE SOUTH 85°41'53" EAST 501.78 FEET TO THE EXTENSION OF THE SOUTHERLY BOUNDARY OF ELKHORN SUBDIVISION, PHASE 2, LOTS 24 THROUGH 28 AMENDED; THENCE ALONG SAID BOUNDARY LINE AND ITS EXTENSION SOUTH 89°07'48" EAST 256.48 FEET TO THE WESTERLY BOUNDARY OF EAGLES LANDING AT WOLF CREEK SUBDIVISION PHASE 1; THENCE ALONG SAID BOUNDARY ALONG THE ARC OF A CURVE TO THE LEFT 54.77 FEET, HAVING A RADIUS OF 40.00 FEET, A CENTRAL ANGLE OF 78°27'04", AND WHICH CHORD BEARS SOUTH 0°32'31" WEST 50.59 FEET; THENCE SOUTH 0°00'00" WEST 167.52 FEET; THENCE NORTH 90°00'00" WEST 329.11 FEET; THENCE ALONG THE ARC OF A CURVE TO THE RIGHT 48.42 FEET, HAVING A RADIUS OF 430.00 FEET, A CENTRAL ANGLE OF 6°27'06", AND WHICH CHORD BEARS NORTH 86°46'27" WEST 48.39 FEET; THENCE NORTH 83°32'54" WEST 63.71 FEET; THENCE ALONG THE ARC OF A CURVE TO THE LEFT 62.67 FEET, HAVING A RADIUS OF 447.77 FEET, A CENTRAL ANGLE OF 8°01'11", AND WHICH CHORD BEARS NORTH 87°33'29" WEST 62.62 FEET; THENCE SOUTH 87°33'13" WEST 102.35 FEET; THENCE ALONG THE ARC OF A CURVE TO THE RIGHT 55.14 FEET, HAVING A RADIUS OF 230.00 FEET, A CENTRAL ANGLE OF 13°44'12", AND WHICH CHORD BEARS NORTH 85°30'41" WEST 55.01 FEET; THENCE SOUTH 33°34'58" WEST 189.46 FEET; THENCE NORTH 65°54'37" WEST 381.87 FEET; THENCE NORTH 67°23'30" WEST 106.53 FEET TO THE EASTERLY BOUNDARY OF SAID RIDGE TOWNHOMES PHASE 1; THENCE ALONG SAID BOUNDARY THE FOLLOWING THREE (3) COURSES: (1) NORTH 22°36'29" EAST 73.07 FEET; (2) NORTH 22°36'29" EAST 73.07 FEET; (3) NORTH 55°54'27" EAST 32.08 FEET TO THE SOUTHERLY BOUNDARY OF THE RIDGE TOWNHOMES PHASE 2; THENCE ALONG SAID BOUNDARY THE FOLLOWING SEVEN (7) COURSES: (1) SOUTH 77°03'57" EAST 120.62 FEET; (2) SOUTH 86°56'20" EAST 93.96 FEET; (3) SOUTH 78°56'27" EAST 55.89 FEET; (4) SOUTH 89°13'42" EAST 26.79 FEET; (5) NORTH 62°48'50" EAST 48.19 FEET; (6) NORTH 42°52'45" EAST 60.00 FEET; (7) NORTH 47°07'15" WEST 49.98 FEET TO THE BOUNDARY OF SAID RIDGE TOWNHOMES PHASE 1; THENCE ALONG SAID BOUNDARY NORTH 42°52'41" EAST 89.68 FEET TO THE POINT OF BEGINNING, CONTAINING 5.89 ACRES, MORE OR LESS.

### SURVEYOR'S CERTIFICATE

I, KLINT H. WHITNEY, DO HEREBY CERTIFY THAT I AM A LICENSED PROFESSIONAL LAND SURVEYOR IN THE STATE OF UTAH AND THAT I HOLD CERTIFICATE NO. 8227228 IN ACCORDANCE WITH TITLE 58, CHAPTER 22, OF THE PROFESSIONAL ENGINEERS AND LAND SURVEYORS ACT; I FURTHER CERTIFY THAT BY AUTHORITY OF THE OWNERS I HAVE COMPLETED A SURVEY OF THE PROPERTY AS SHOWN AND DESCRIBED ON THIS PLAT IN ACCORDANCE WITH SECTION 17-23-20 AND HAVE VERIFIED ALL MEASUREMENTS; THAT THE REFERENCE MONUMENTS SHOWN HEREON ARE LOCATED AS INDICATED AND ARE SUFFICIENT TO RETRACE OR REESTABLISH THIS PLAT; AND THAT THE INFORMATION SHOWN HEREIN IS SUFFICIENT TO ACCURATELY ESTABLISH THE LATERAL BOUNDARIES OF THE HEREIN DESCRIBED TRACT OF REAL PROPERTY; AND THAT THIS PLAT OF:

This is Utah code for final local entity plats

IN WEBER COUNTY, UTAH HAS BEEN DRAWN CORRECTLY TO THE DESIGNATED SCALE AND IS A TRUE AND CORRECT REPRESENTATION OF THE HEREIN DESCRIBED LANDS INCLUDED IN SAID SUBDIVISION, BASED UPON DATA COMPILED FROM RECORDS IN THE WEBER COUNTY RECORDERS OFFICE; I FURTHER CERTIFY THAT THE REQUIREMENTS OF ALL APPLICABLE STATUTES AND ORDINANCES OF WEBER COUNTY CONCERNING ZONING REQUIREMENTS REGARDING LOT MEASUREMENTS HAVE BEEN COMPLIED WITH.

Needs to read "has placed monuments as represented on the plat". USC 17-27a-604(4)(b)(iii)

PROFESSIONAL LAND SURVEYOR  
8227228  
Klint H. Whitney  
STATE OF UTAH

SIGNED THIS \_\_\_\_\_ DAY OF \_\_\_\_\_, 2016. KLINT H. WHITNEY, PLS NO. 8227228

### OWNER'S DEDICATION

RIDGE UTAH DEVELOPMENT CORPORATION (RUDCO) AS OWNER OF THE TRACT OF LAND DESCRIBED HEREON, AND AS DECLARANT OF THAT CERTAIN PROJECT KNOWN AS THE RIDGE TOWNHOMES PHASE 3, HEREBY DEDICATES TO PUBLIC USE ALL THOSE PARTS OR PORTIONS OF SAID TRACT OF LAND DESIGNATED AS PUBLIC STREETS, THE SAME TO BE USED AS PUBLIC THOROUGHFARES. RUDCO FURTHER DEDICATES AND RESERVES UNTO ITSELF, INCLUDING ITS GRANTEES, SUCCESSORS AND ASSIGNS, A RIGHT-OF-WAY TO BE USED IN COMMON WITH ALL OTHERS WITHIN SAID PROJECT (AND THOSE ADJOINING PROJECTS OR SUBDIVISIONS THAT MAY BE SUBDIVIDED BY SAID OWNER/DECLARANT, ITS SUCCESSORS OR ASSIGNS) ON, OVER AND ACROSS ALL THOSE PORTIONS OR PARTS OF SAID TRACT OF LAND DESIGNATED ON SAID PLAT AS PRIVATE STREETS AS ACCESS TO THE INDIVIDUAL LOTS/UNIT, TO BE MAINTAINED BY THE RIDGE TOWNHOMES ASSOCIATION, WHICH SHALL BE GOVERNED IN ACCORDANCE WITH THE UTAH COMMUNITY ASSOCIATION ACT AND WHOSE MEMBERSHIP SHALL CONSIST OF THE OWNERS OF SAID LOTS/UNITS, THEIR GRANTEES, SUCCESSORS, OR ASSIGNS. RUDCO ALSO GRANTS AND CONVEYS TO THE RIDGE TOWNHOMES ASSOCIATION ALL THOSE PARTS OR PORTIONS OF SAID TRACT OF LAND DESIGNATED AS COMMON AREAS TO BE USED FOR RECREATIONAL AND OPEN SPACE PURPOSES FOR THE BENEFIT OF EACH RIDGE TOWNHOMES ASSOCIATION MEMBER IN COMMON WITH ALL OTHERS IN THE PROJECT.

RUDCO GRANTS AND DEDICATES TO WEBER COUNTY A PERPETUAL EASEMENT ON AND OVER THE COMMON AREAS TO GUARANTEE TO WEBER COUNTY THAT THE COMMON AREAS REMAIN OPEN AND UNDEVELOPED EXCEPT FOR APPROVED RECREATIONAL, PARKING AND OPEN SPACE PURPOSES. RUDCO ALSO GRANTS AND DEDICATES TO WEBER COUNTY A PERPETUAL EASEMENT FOR PROVIDING AND MAINTAINING CONSTRUCTION CUT AND/OR FILL SLOPES, LATERAL SUPPORT AND/OR PROPER DRAINAGE ADJACENT TO THE PUBLIC RIGHT-OF-WAY LOCATED WITHIN THE PROJECT.

RUDCO GRANTS AND DEDICATES A PERPETUAL RIGHT AND EASEMENT FOR PUBLIC UTILITY PURPOSES OVER, UPON AND UNDER THE PROJECT.

A. STORM WATER DETENTION PONDS, DRAINAGE EASEMENTS AND CANAL MAINTENANCE EASEMENT THE SAME TO BE USED FOR THE INSTALLATION MAINTENANCE AND OPERATION OF PUBLIC UTILITY SERVICE LINES, STORM DRAINAGE FACILITIES, IRRIGATION CANALS OR FOR THE PERPETUAL PRESERVATION OF WATER CHANNELS IN THEIR NATURAL STATE WHICHEVER IS APPLICABLE AS MAY BE AUTHORIZED BY THE GOVERNING AUTHORITY, WITH NO BUILDINGS OR STRUCTURES BEING ERRECTED WITHIN SUCH EASEMENTS.

B. PRIVATE OWNERSHIP WILL BE DEFINED AS ANYTHING WITHIN THE FOOTPRINT OF THE INDIVIDUAL LOTS/UNITS AS SHOWN ON SHEET 3.

C. LIMITED COMMON AREA TO BE EXCLUDED FROM PUBLIC UTILITY EASEMENT DEDICATION.

RIDGE UTAH DEVELOPMENT CORPORATION  
SIGNED THIS \_\_\_\_\_ DAY OF \_\_\_\_\_, 2016. ERIC S. HOUSEHOLDER, OFFICER

RIDGE TOWNHOMES ASSOCIATION  
SIGNED THIS \_\_\_\_\_ DAY OF \_\_\_\_\_, 2016. ERIC S. HOUSEHOLDER, OFFICER

### SITE SUMMARY

TOTAL AREA	= 5.90 AC
BUILDING COVERAGE	= 0.55 AC
HARD SURFACE AREA	= 0.28 AC
LANDSCAPE AREA	= 3.92 AC
DEDICATED ROAD AREA	= 1.15 AC

- ### LEGEND
- WEBER COUNTY MONUMENT AS NOTED
  - SET 24" REBAR AND CAP MARKED GARDNER ENGINEERING
  - STREET MONUMENT
  - SECTION LINE
  - CENTERLINE
  - RIGHT-OF-WAY LINE
  - PROPERTY BOUNDARY
  - BUILDING TIES
  - PRIVATE
  - LIMITED COMMON AREA
  - COMMON AREA

### NARRATIVE

THE PURPOSE OF THIS SURVEY WAS TO CREATE A P.R.U.D. SUBDIVISION PLAT AS SHOWN AND DESCRIBED HEREON. THE SURVEY WAS ORDERED BY JOHN L. LEWIS. THE CONTROL USED TO ESTABLISH THE BOUNDARY WAS THE EXISTING WEBER COUNTY SURVEY MONUMENTATION SURROUNDING SECTION 27, TOWNSHIP 7 NORTH, RANGE 1 EAST OF THE SALT LAKE BASE AND MERIDIAN. THE BASIS OF BEARING IS THE NORTH LINE OF THE NORTHEAST QUARTER OF SAID SECTION WHICH BEARS SOUTH 89°09'42" EAST 2656.14 FEET, WEBER COUNTY, NAD 83, STATE PLANE GRID BEARING.

### ADDRESS TABLE

UNIT 501
UNIT 502
UNIT 503
UNIT 504
UNIT 601
UNIT 602
UNIT 603
UNIT 604
UNIT 701
UNIT 702
UNIT 703
UNIT 704

### NOTE

A GEOTECHNICAL INVESTIGATION WAS COMPLETED FOR THIS SUBDIVISION BY GEO-STRATA, JOB NUMBER 924-001 DECEMBER 3, 2013. A COPY OF THIS REPORT IS AVAILABLE AT THEIR OFFICE (1442S SOUTH, CENTER POINT WAY, BLUFFDALE, UTAH).

### WEBER COUNTY PLANNING COMMISSION APPROVAL

THIS IS TO CERTIFY THAT THIS SUBDIVISION WAS DULY APPROVED BY THE WEBER COUNTY PLANNING COMMISSION.

SIGNED THIS \_\_\_\_\_ DAY OF \_\_\_\_\_, 2016.

CHAIRMAN, WEBER COUNTY PLANNING COMMISSION

### WEBER COUNTY ATTORNEY

I HAVE EXAMINED THE FINANCIAL GUARANTEE AND OTHER DOCUMENTS ASSOCIATED WITH THIS SUBDIVISION PLAT AND IN MY OPINION THEY CONFORM WITH THE COUNTY ORDINANCE APPLICABLE THERETO AND NOW IN FORCE AND EFFECT.

SIGNED THIS \_\_\_\_\_ DAY OF \_\_\_\_\_, 2016.

COUNTY ATTORNEY

### WEBER COUNTY ENGINEER

I HEREBY CERTIFY THAT THE REQUIRED PUBLIC IMPROVEMENT STANDARDS AND DRAWINGS FOR THIS SUBDIVISION CONFORM WITH COUNTY STANDARDS AND THE AMOUNT OF THE FINANCIAL GUARANTEE IS SUFFICIENT FOR THE INSTALLATION OF THESE IMPROVEMENTS.

SIGNED THIS \_\_\_\_\_ DAY OF \_\_\_\_\_, 2016.

COUNTY ENGINEER

### WEBER COUNTY SURVEYOR

I HEREBY CERTIFY THAT THE WEBER COUNTY SURVEYOR'S OFFICE HAS REVIEWED THIS PLAT FOR MATHEMATICAL CORRECTNESS, SECTION CORNER DATA, AND FOR HARMONY WITH LINES AND MONUMENTS ON RECORD IN COUNTY OFFICES. THE APPROVAL OF THIS PLAT BY THE WEBER COUNTY SURVEYOR DOES NOT RELIEVE THE LICENSED LAND SURVEYOR WHO EXECUTED THIS PLAT FROM THE RESPONSIBILITIES AND/OR LIABILITIES ASSOCIATED THERewith.

SIGNED THIS \_\_\_\_\_ DAY OF \_\_\_\_\_, 2016.

COUNTY SURVEYOR

### WEBER COUNTY COMMISSION ACCEPTANCE

THIS IS TO CERTIFY THAT THIS SUBDIVISION PLAT, THE DEDICATION OF STREETS AND OTHER PUBLIC WAYS AND FINANCIAL GUARANTEE OF PUBLIC IMPROVEMENTS ASSOCIATED WITH THIS SUBDIVISION THEREON ARE HEREBY APPROVED AND ACCEPTED BY THE COMMISSIONERS OF WEBER COUNTY, UTAH.

SIGNED THIS \_\_\_\_\_ DAY OF \_\_\_\_\_, 2016.

CHAIRMAN, WEBER COUNTY COMMISSION

### WEBER - MORGAN HEALTH DEPARTMENT

I DO HEREBY CERTIFY THAT THE SOILS, PERCOLATION RATES, AND SITE CONDITION FOR THIS SUBDIVISION HAVE BEEN INVESTIGATED BY THIS OFFICE AND ARE APPROVED FOR ON-SITE WASTEWATER DISPOSAL SYSTEMS.

THIS \_\_\_\_\_ DAY OF \_\_\_\_\_, 2016

DIRECTOR WEBER-MORGAN HEALTH DEPARTMENT

### ACKNOWLEDGEMENT

STATE OF UTAH )  
 COUNTY OF WEBER )

ON THIS \_\_\_\_\_ DAY OF \_\_\_\_\_, 2016, PERSONALLY APPEARED BEFORE ME ERIC S. HOUSEHOLDER, THE SIGNER OF THE ABOVE OWNER'S DEDICATION, WHO DULY ACKNOWLEDGED TO ME HE SIGNED IT FREELY AND VOLUNTARILY AND FOR THE PURPOSES THEREIN MENTIONED.

THIS \_\_\_\_\_ DAY OF \_\_\_\_\_, 2016

STAMP NOTARY PUBLIC

### COUNTY RECORDER

ENTRY NO. \_\_\_\_\_ FEE PAID \_\_\_\_\_  
 FILED FOR AND RECORDED \_\_\_\_\_  
 AT \_\_\_\_\_ IN BOOK \_\_\_\_\_ OF OFFICIAL RECORDS, PAGE \_\_\_\_\_, RECORDED FOR \_\_\_\_\_  
 COUNTY RECORDER BY: \_\_\_\_\_

**S1**  
7

**GARDNER ENGINEERING**  
 CIVIL - LAND PLANNING  
 MUNICIPAL - LAND SURVEYING  
 5150 SOUTH 375 EAST OGDEN, UT  
 OFFICE: 801.476.0202 FAX: 801.476.0066

LOCALSHARES\LAND\_DESKTOP1201 - LEWIS HOMES1303 - THE RIDGE TOWNHOMES PHASE 3



# THE RIDGE TOWNHOMES PHASE 3

A PLANNED RESIDENTIAL UNIT DEVELOPMENT (P.R.U.D)  
 PART OF THE NORTHEAST 1/4 OF SECTION 27  
 T7N, R1E, SLB & M, US SURVEY  
 WEBER COUNTY, UTAH  
 SEPTEMBER 2016

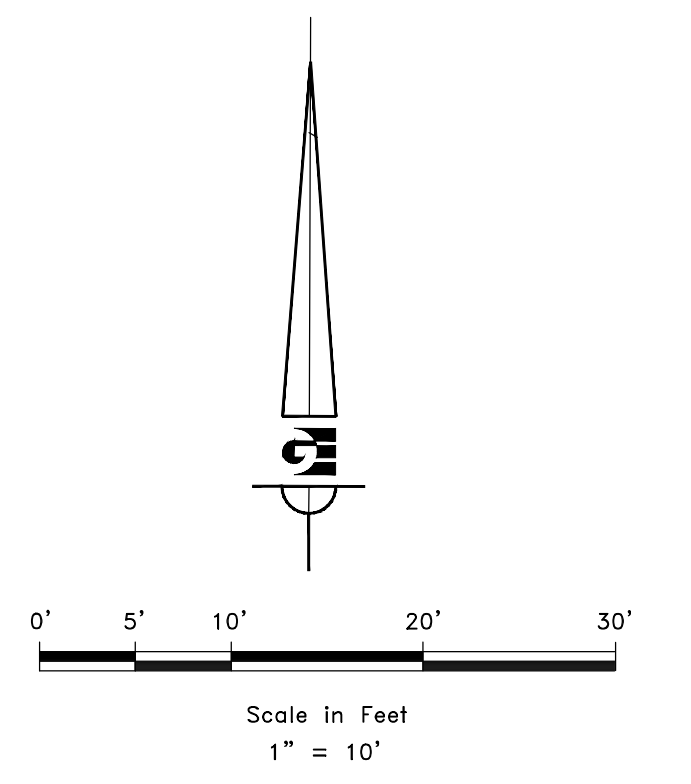
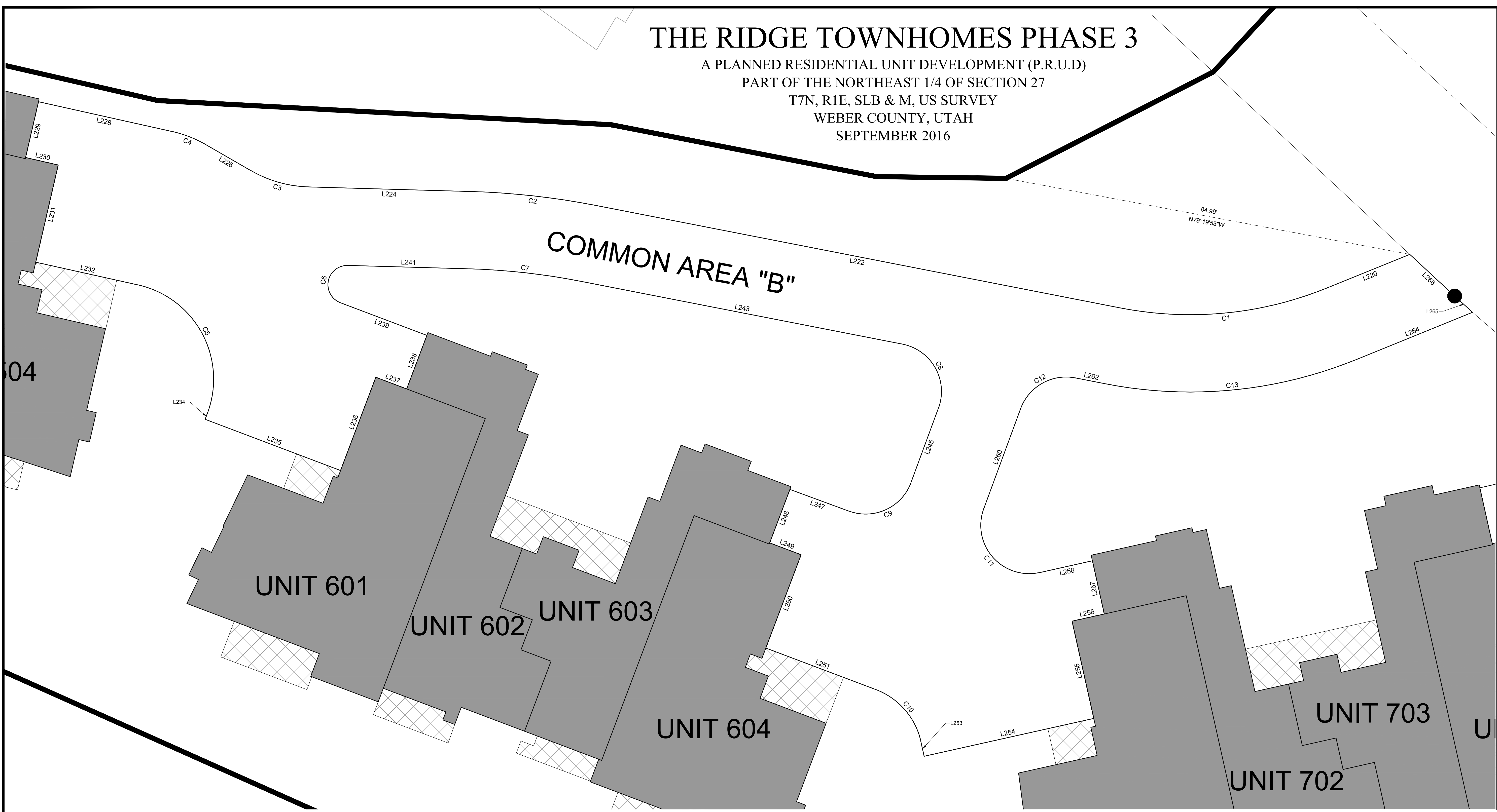

### LEGEND

- WEBER COUNTY MONUMENT AS NOTED
- SET 24" REBAR AND CAP MARKED GARDNER ENGINEERING
- STREET MONUMENT
- SECTION LINE
- CENTERLINE
- RIGHT-OF-WAY LINE
- PROPERTY BOUNDARY
- BUILDING TIES
- PRIVATE
- LIMITED COMMON AREA
- COMMON AREA

### COMMON AREA "B" LINE AND CURVE TABLES

LINE TABLE		
LINE #	LENGTH	BEARING
L220	18.52	S67° 52' 45"W
L222	110.73	N78° 56' 27"W
L224	33.57	N88° 23' 08"W
L226	10.86	N60° 03' 40"W
L228	28.26	N77° 27' 01"W
L229	11.84	S13° 01' 29"W
L230	6.94	S76° 58' 31"E
L231	20.63	S13° 01' 29"W
L232	21.65	S77° 27' 01"E
L234	1.31	S20° 41' 45"W
L235	29.95	S69° 18' 18"E
L236	20.62	N20° 41' 42"E
L237	6.83	S69° 18' 18"E
L238	11.83	N20° 41' 45"E
L239	19.11	N69° 18' 15"W

LINE TABLE		
LINE #	LENGTH	BEARING
L241	24.92	S88° 23' 08"E
L243	67.81	S78° 56' 27"E
L245	16.38	S20° 13' 13"W
L247	13.01	N69° 46' 47"W
L248	11.83	S20° 41' 42"W
L249	6.94	S69° 18' 18"E
L250	20.64	S20° 41' 42"W
L251	24.30	S69° 18' 15"E
L253	3.13	S12° 35' 10"E
L254	35.95	N77° 24' 50"E
L255	20.63	N12° 35' 13"W
L256	6.83	N77° 24' 47"E
L257	11.28	N12° 35' 13"W
L258	11.18	S77° 24' 50"W
L260	22.08	N20° 13' 13"E

LINE TABLE		
LINE #	LENGTH	BEARING
L262	6.46	S78° 56' 27"E
L264	26.04	N67° 52' 45"E
L265	4.99	N47° 44' 32"W
L266	12.69	N47° 07' 12"W

CURVE TABLE					
CURVE #	LENGTH	RADIUS	DELTA	CHORD BEARING	CHORD LENGTH
C1	43.43	75.00	33.18	S84° 28' 09"W	42.83
C2	26.05	158.00	9.44	N83° 39' 48"W	26.02
C3	12.36	25.00	28.32	N74° 13' 24"W	12.23
C4	7.59	25.00	17.39	N68° 45' 20"W	7.56
C5	34.26	20.00	98.15	S28° 22' 38"E	30.22
C6	11.23	4.00	160.92	N11° 09' 18"E	7.89
C7	23.41	142.00	9.44	S83° 39' 48"E	23.38
C8	17.31	10.00	99.16	S29° 21' 37"E	15.23
C9	15.71	10.00	90.00	S65° 13' 13"W	14.14
C10	14.85	15.00	56.72	S40° 56' 43"E	14.25
C11	21.43	10.00	122.81	N41° 10' 59"W	17.56
C12	14.11	10.00	80.84	N60° 38' 23"E	12.97
C13	52.70	91.00	33.18	N84° 28' 09"E	51.96

I:\LOCAL\SHARES\LAND\_DESKTOP\1201 - LEWIS HOMES\1303 - THE RIDGE\_TOWNHOMES\PHASE 3\DWG\COMMON AREA "B" LINE AND CURVE TABLES.DWG

OWNER: RIDGE UTAH DEVELOPMENT CORPORATION JOHN L. LEWIS 3718 NORTH WOLF CREEK DRIVE EDEN, UTAH 84310 801-430-1507 SEE RECORD OF SURVEY # 5332	<b>S3</b> <hr/> <b>7</b>	COUNTY RECORDER ENTRY NO. _____ FEE PAID _____ FILED FOR AND RECORDED _____ AT _____ IN BOOK _____ OF OFFICIAL RECORDS, PAGE _____, RECORDED FOR _____ _____ COUNTY RECORDER BY: _____
	GARDNER ENGINEERING CIVIL - LAND PLANNING MUNICIPAL - LAND SURVEYING 5150 SOUTH 375 EAST OGDEN, UT OFFICE: 801.476.0202 FAX: 801.476.0066	

# THE RIDGE TOWNHOMES PHASE 3

A PLANNED RESIDENTIAL UNIT DEVELOPMENT (P.R.U.D)  
 PART OF THE NORTHEAST 1/4 OF SECTION 27  
 T7N, R1E, SLB & M, US SURVEY  
 WEBER COUNTY, UTAH  
 SEPTEMBER 2016

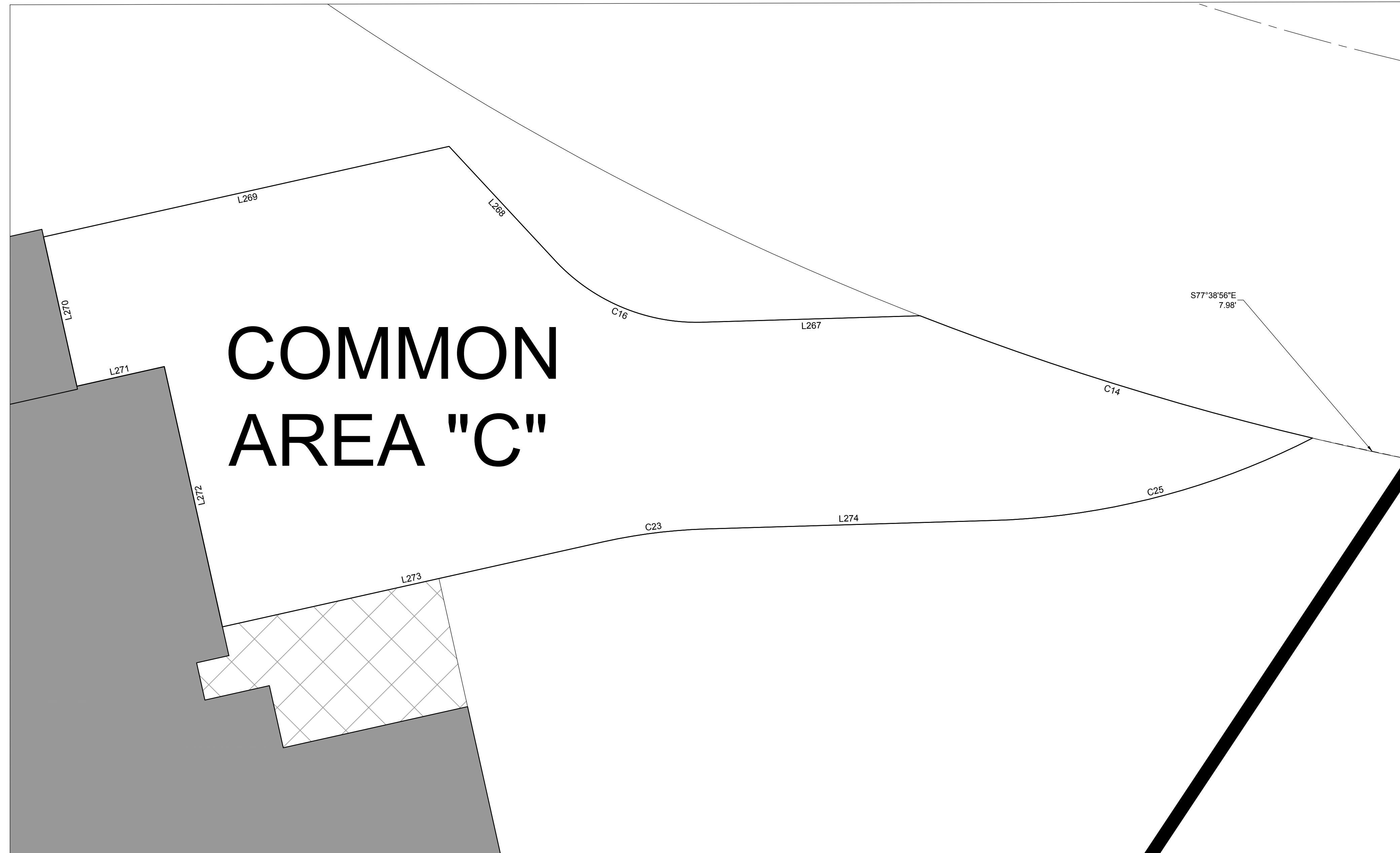
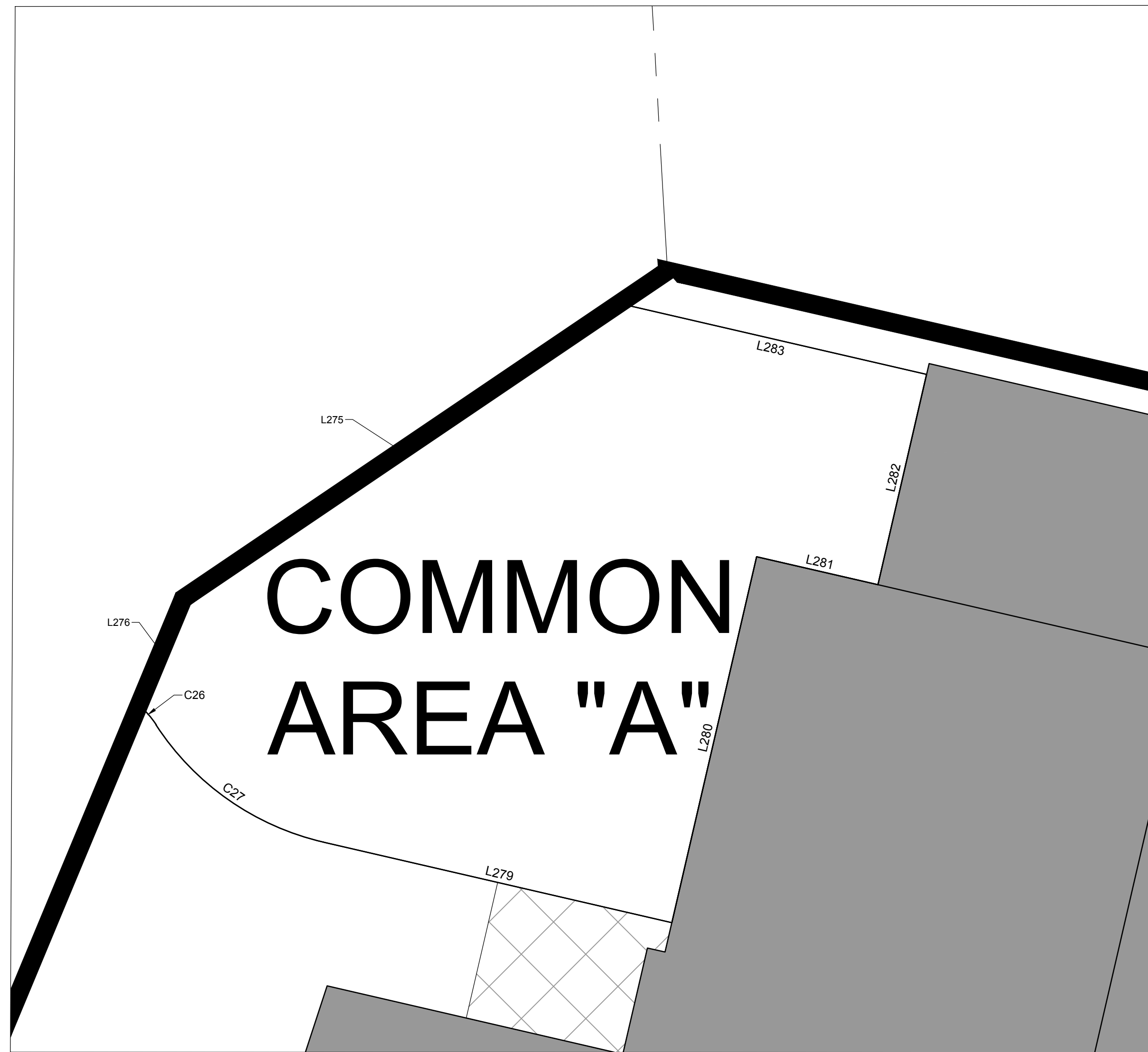

**COMMON AREA "A" LINE AND CURVE TABLES**

LINE TABLE		
LINE #	LENGTH	BEARING
L275	28.90	S55° 54' 27"W
L276	6.34	S22° 36' 25"W
L279	19.62	S76° 58' 31"E
L280	20.62	N13° 01' 29"E
L281	6.83	S76° 58' 31"E
L282	11.85	N13° 01' 31"E
L283	17.30	N76° 58' 29"W

CURVE TABLE					
CURVE #	LENGTH	RADIUS	DELTA	CHORD BEARING	CHORD LENGTH
C26	1.44	5.00	16.52	S41° 18' 37"E	1.44
C27	11.50	15.00	43.92	S55° 00' 47"E	11.22

**COMMON AREA "C" LINE AND CURVE TABLES**

LINE TABLE		
LINE #	LENGTH	BEARING
L267	16.83	S88° 18' 23"W
L268	12.04	N42° 52' 13"W
L269	32.16	S77° 24' 50"W
L270	11.83	S12° 35' 13"E
L271	6.94	N77° 24' 47"E
L272	20.64	S12° 35' 13"E
L273	30.21	N77° 24' 50"E
L274	22.21	N88° 18' 23"E

CURVE TABLE					
CURVE #	LENGTH	RADIUS	DELTA	CHORD BEARING	CHORD LENGTH
C14	31.84	230.00	7.93	N72° 41' 19"W	31.82
C16	12.78	15.00	48.82	N67° 16' 55"W	12.40
C23	7.98	42.00	10.89	N82° 51' 36"E	7.97
C25	25.79	58.00	25.47	N75° 34' 09"E	25.58

- LEGEND**
- WEBER COUNTY MONUMENT AS NOTED
  - SET 24" REBAR AND CAP MARKED GARDNER ENGINEERING
  - STREET MONUMENT
  - SECTION LINE
  - CENTERLINE
  - RIGHT-OF-WAY LINE
  - PROPERTY BOUNDARY
  - BUILDING TIES
  - PRIVATE
  - LIMITED COMMON AREA
  - COMMON AREA

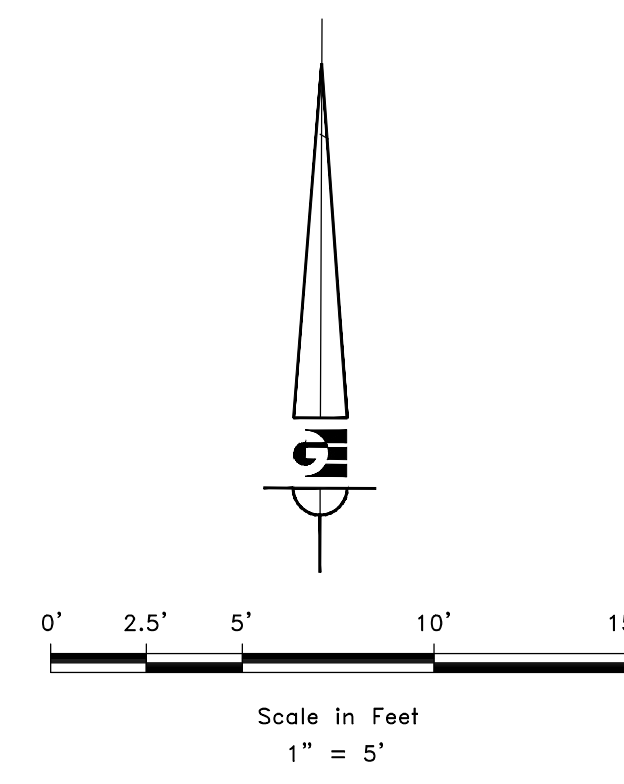

OWNER: RIDGE UTAH DEVELOPMENT CORPORATION JOHN L. LEWIS 3718 NORTH WOLF CREEK DRIVE EDEN, UTAH 84310 801-430-1507 SEE RECORD OF SURVEY # 5332	<b>S4</b> <hr/> <b>7</b>	COUNTY RECORDER ENTRY NO. _____ FEE PAID _____ FILED FOR AND RECORDED _____ AT _____ IN BOOK _____ OF OFFICIAL RECORDS, PAGE _____, RECORDED FOR _____ COUNTY RECORDER BY: _____
		<b>GARDNER ENGINEERING</b> CIVIL - LAND PLANNING MUNICIPAL - LAND SURVEYING 5150 SOUTH 375 EAST OGDEN, UT OFFICE: 801.476.0202 FAX: 801.476.0066

I:\LOCAL\SHARES\LAND\_DESKTOP\1201 - LEWIS HOMES\1303 - THE RIDGE\_TOWNHOMES\PHASE 3\DWG\COMMON AREAS\COMMON AREAS PHASE 3.DWG





# THE RIDGE TOWNHOMES PHASE 3

A PLANNED RESIDENTIAL UNIT DEVELOPMENT (P.R.U.D)  
 PART OF THE NORTHEAST 1/4 OF SECTION 27  
 T7N, R1E, SLB & M, US SURVEY  
 WEBER COUNTY, UTAH  
 SEPTEMBER 2016



**SOUTH ELEVATION**  
 BUILDINGS 501-504 100'-00" = 5242.50  
 BUILDINGS 601-604 100'-00" = 5245.00  
 BUILDINGS 701-704 100'-00" = 5245.00

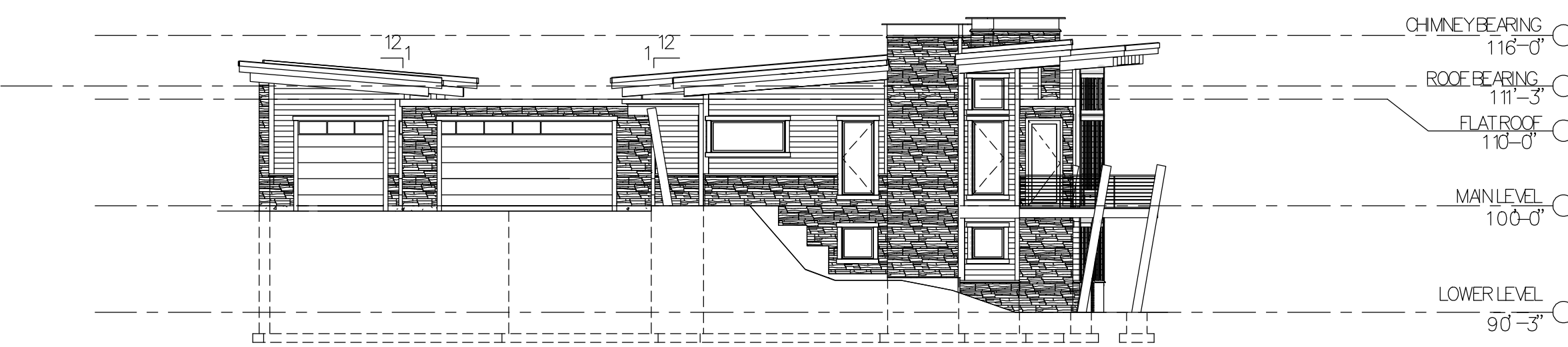

**WEST ELEVATION**  
 BUILDINGS 501-504 100'-00" = 5242.50  
 BUILDINGS 601-604 100'-00" = 5245.00  
 BUILDINGS 701-704 100'-00" = 5245.00

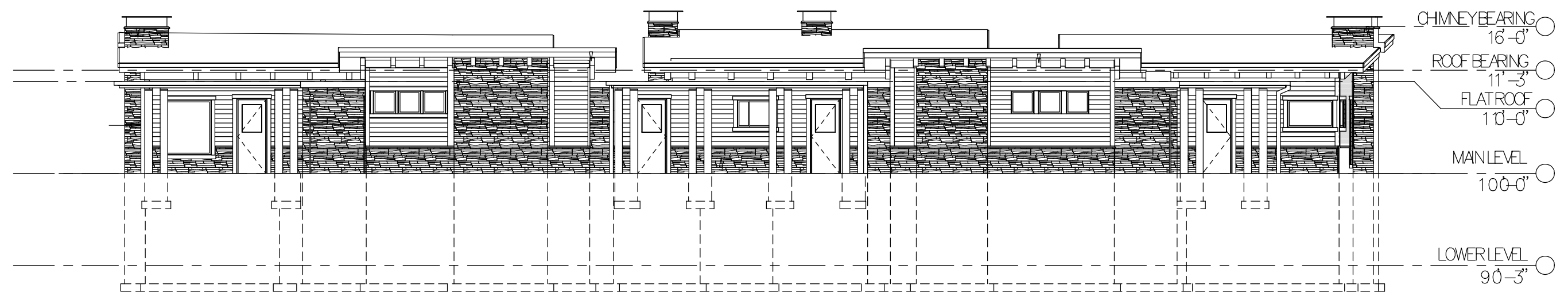

**NORTH ELEVATION**  
 BUILDINGS 501-504 100'-00" = 5242.50  
 BUILDINGS 601-604 100'-00" = 5245.00  
 BUILDINGS 701-704 100'-00" = 5245.00

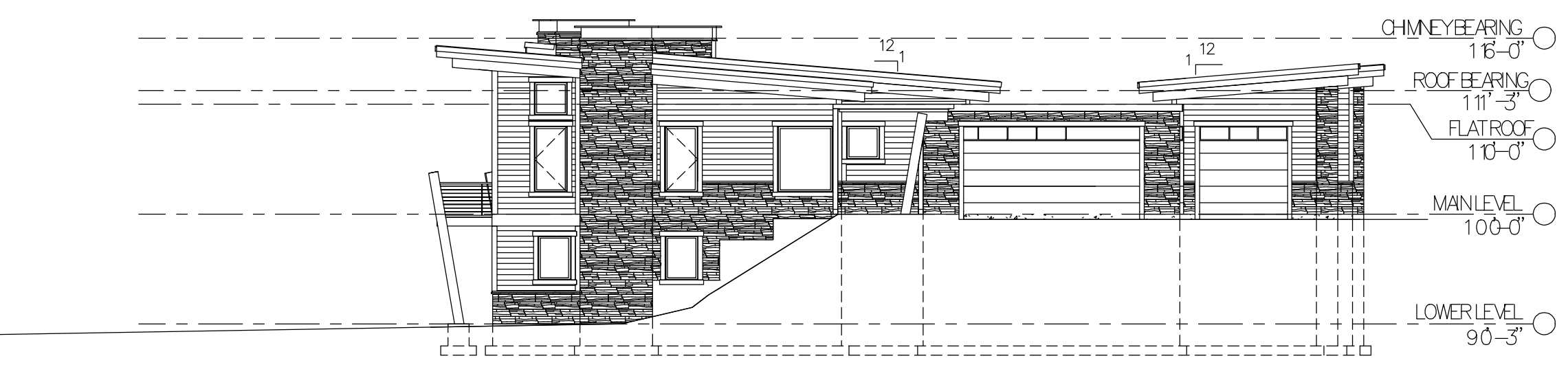

**EAST ELEVATION**  
 BUILDINGS 501-504 100'-00" = 5242.50  
 BUILDINGS 601-604 100'-00" = 5245.00  
 BUILDINGS 701-704 100'-00" = 5245.00

I:\LOCAL\SHARES\LAND\_DESKTOP\1201 - LEWIS HOMES\1303 - THE RIDGE\_TOWNHOMES\PHASE 3\DWG

OWNER: RIDGE UTAH DEVELOPMENT CORPORATION JOHN L. LEWIS 3718 NORTH WOLF CREEK DRIVE EDEN, UTAH 84310 801-430-1507 SEE RECORD OF SURVEY # 5332	<b>S7</b> <hr/> <b>7</b>	COUNTY RECORDER ENTRY NO. _____ FEE PAID _____ FILED FOR AND RECORDED _____ AT _____ IN BOOK _____ OF OFFICIAL RECORDS, PAGE _____, RECORDED FOR _____ COUNTY RECORDER BY: _____
	 <b>GARDNER ENGINEERING</b> CIVIL - LAND PLANNING MUNICIPAL - LAND SURVEYING 5150 SOUTH 375 EAST OGDEN, UT OFFICE: 801.476.0202 FAX: 801.476.0066	