

PLANT SCHEDULE PHASE 1

TREES	QTY	COMMON NAME / BOTANICAL NAME	CONT	CAL	SIZE
	21	Autumn Blaze Maple / Acer freemanii 'Autumn Blaze'	B & B		2'Cal
	7	Canada Red Chokecherry / Prunus virginiana 'Canada Red'	B & B		2'Cal
	25	Quaking Aspen / Populus tremuloides	B & B		2'Cal
	15	Spring Snow Crab Apple / Malus x 'Spring Snow'	B & B		2'Cal
EVERGREEN TREES	QTY	COMMON NAME / BOTANICAL NAME	CONT	CAL	SIZE
	60	Bakeri Blue Spruce / Picea pungens glauca 'Bakeri'	B & B		8-10'
SHRUBS	QTY	COMMON NAME / BOTANICAL NAME	CONT		
	28	Arctic Fire Dogwood / Cornus sanguinea 'Arctic Fire'™	5 gal		
	30	Black Lace Elderberry / Sambucus nigra 'Black Lace'	5 gal		
	18	Compact Burning Bush / Euonymus alatus 'Compactus'	5 gal		
	30	Crimson Pygmy Barberry / Berberis thunbergii 'Crimson Pygmy'	5 gal		
	28	Diablo Ninebark / Physocarpus opulifolius 'Diablo'	5 gal		
	9	Dwarf Ninebark / Physocarpus opulifolius 'Nanus'	5 gal		
	4	Hailhedge Buckthorn / Rhamnus frangula columnaris	5 gal		
	21	Magic Carpet Spiraea / Spiraea japonica 'Magic Carpet'	5 gal		
	9	Northern Gold Forsythia / Forsythia x 'Northern Gold'	5 gal		
EVERGREEN SHRUBS	QTY	COMMON NAME / BOTANICAL NAME	CONT		
	15	Mugo Pine / Pinus mugo 'Slowmound'	5 gal		
	17	Oregon Grape / Mahonia aquifolium 'Apollo'	5 gal		
GRASSES	QTY	COMMON NAME / BOTANICAL NAME	CONT		
	10	Feather Reed Grass / Calamagrostis x acutiflora 'Karl Foerster'	1 gal		
PERENNIALS	QTY	COMMON NAME / BOTANICAL NAME	CONT		
	10	Black-eyed Susan / Rudbeckia fulgida sultivansi 'Goldsturm'	1 gal		
	5	Stella de Oro Daylily / Hemerocallis x 'Stella de Oro'	1 gal		
GROUND COVERS	QTY	COMMON NAME / BOTANICAL NAME	CONT		
	165,339 sf	Kentucky Bluegrass / Poa pratensis	sod		
	71,665 sf	Wild Flower / Native Grass Mix / Wild Flower / Native Grass Mix	Hydroseed		
MULCH	QTY	COMMON NAME / BOTANICAL NAME	CONT		
	40,726 sf	Wood Mulch / Wood Mulch	Mulch		

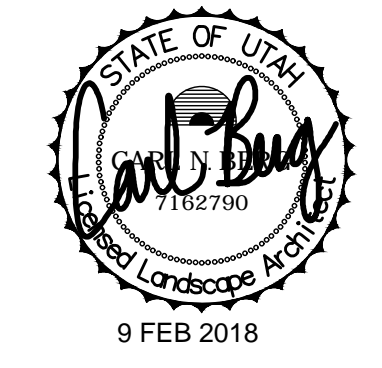

WATTS ENTERPRISES
FAIRWAYS AT WOLF CREEK PH. 4

SITE PLAN AND PLANTING PLAN

380 E Main St, Suite 204
Midway, Ut 84049 ph. (801) 723-2000





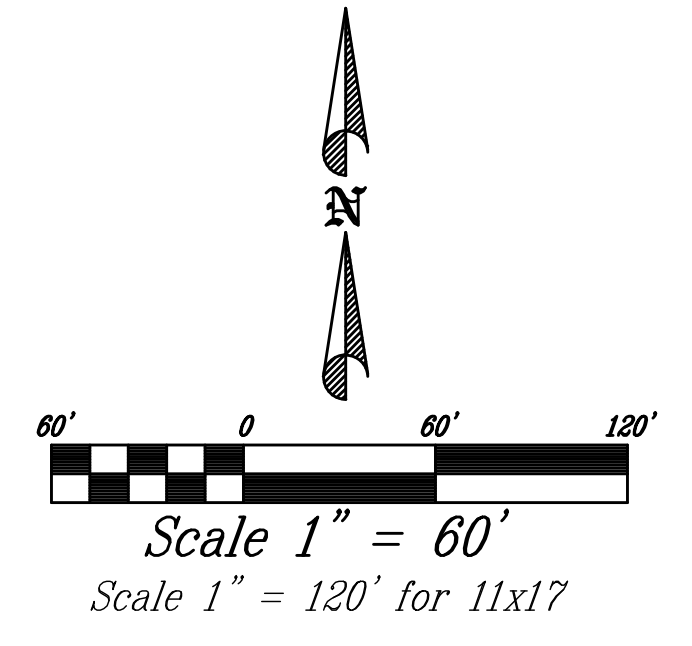

DESIGN BY: CNB
DRAWN BY: DAW

DATE: 9 FEB 2018
REV:

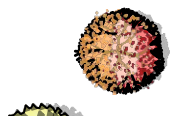
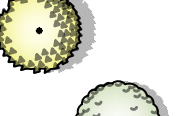
SHEET L01

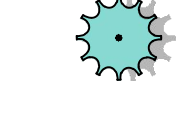

PLANT SCHEDULE PHASE 2

TREES	QTY	COMMON NAME / BOTANICAL NAME	CONT	CAL	SIZE
	23	Autumn Blaze Maple / Acer freemanii 'Autumn Blaze'	B & B		2"Cal
	23	Quaking Aspen / Populus tremuloides	B & B		2"Cal
	3	Spring Snow Crab Apple / Malus x 'Spring Snow'	B & B		2"Cal
EVERGREEN TREES	QTY	COMMON NAME / BOTANICAL NAME	CONT	CAL	SIZE
	14	Bakeri Blue Spruce / Picea pungens glauca 'Bakeri'	B & B		8-10'
GROUND COVERS	QTY	COMMON NAME / BOTANICAL NAME	CONT		
	67,134 sf	Kentucky Bluegrass / Poa pratensis	sod		
	34,726 sf	Wild Flower / Native Grass Mix / Wild Flower / Native Grass Mix	Hydroseed		
MULCH	QTY	COMMON NAME / BOTANICAL NAME	CONT		
	31,121 sf	Wood Mulch / Wood Mulch	Mulch		

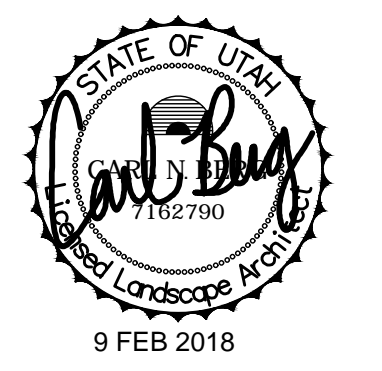

WATTS ENTERPRISES
FAIRWAYS AT WOLF CREEK PH. 4

SITE PLAN AND PLANTING PLAN







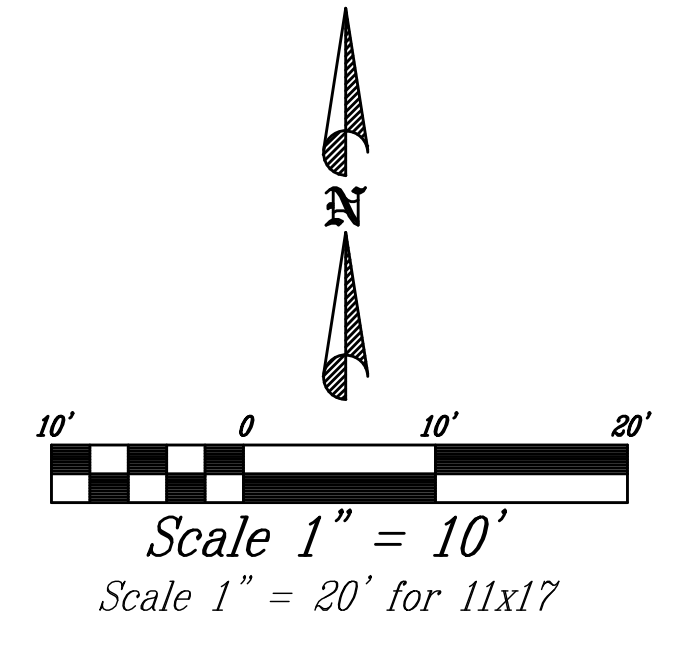



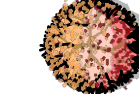







380 E Main St, Suite 204
Midway, Ut 84049 ph. (801) 723-2000

DESIGN BY: CNB DATE: 9 FEB 2018
DRAWN BY: DAW REV: SHEET L02



PLANT SCHEDULE TYP. BUILDING

TREES	QTY	COMMON NAME / BOTANICAL NAME	CONT	CAL
	1	Autumn Blaze Maple / Acer freemanii 'Autumn Blaze'	B & B	2"Cal
	1	Canada Red Chokecherry / Prunus virginiana 'Canada Red'	B & B	2"Cal
	1	Quaking Aspen / Populus tremuloides	B & B	2"Cal
SHRUBS	QTY	COMMON NAME / BOTANICAL NAME	CONT	
	10	Arctic Fire Dogwood / Cornus sanguinea 'Arctic Fire' TM	5 gal	
	15	Black Lace Elderberry / Sambucus nigra 'Black Lace'	5 gal	
	3	Compact Burning Bush / Euonymus alatus 'Compactus'	5 gal	
	9	Crimson Pygmy Barberry / Berberis thunbergii 'Crimson Pygmy'	5 gal	
	6	Diablo Ninebark / Physocarpus opulifolius 'Diablo'	5 gal	
	9	Dwarf Ninebark / Physocarpus opulifolius 'Nanus'	5 gal	
	4	Hallhedge Buckthorn / Rhamnus frangula columnaris	5 gal	
	11	Magic Carpet Spirea / Spiraea japonica 'Magic Carpet'	5 gal	
	3	Northern Gold Forsythia / Forsythia x 'Northern Gold'	5 gal	
EVERGREEN SHRUBS	QTY	COMMON NAME / BOTANICAL NAME	CONT	
	4	Mugo Pine / Pinus mugo 'Slowmound'	5 gal	
GRASSES	QTY	COMMON NAME / BOTANICAL NAME	CONT	
	10	Feather Reed Grass / Calamagrostis x acutiflora 'Karl Foerster'	1 gal	
PERENNIALS	QTY	COMMON NAME / BOTANICAL NAME	CONT	
	10	Black-eyed Susan / Rudbeckia fulgida sullivantii 'Goldsturm'	1 gal	
	5	Stella de Oro Daylily / Hemerocallis x 'Stella de Oro'	1 gal	
MULCH	QTY	COMMON NAME / BOTANICAL NAME	CONT	
	2,298 sf	Wood Mulch / Wood Mulch	Mulch	

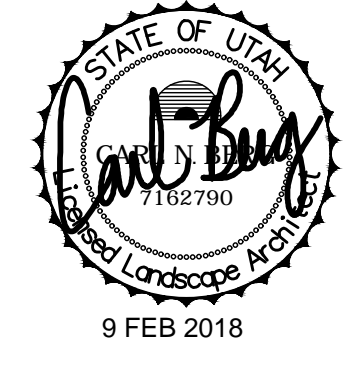

WATTS ENTERPRISES
FAIRWAYS AT WOLF CREEK PH. 4

TYPICAL BUILDING PLAN



380 E Main St, Suite 204
Midway, Ut 84049 ph. (801) 723-2000

DESIGN BY: CNB DATE: 9 FEB 2018
DRAWN BY: DAW REV:

SHEET L03